

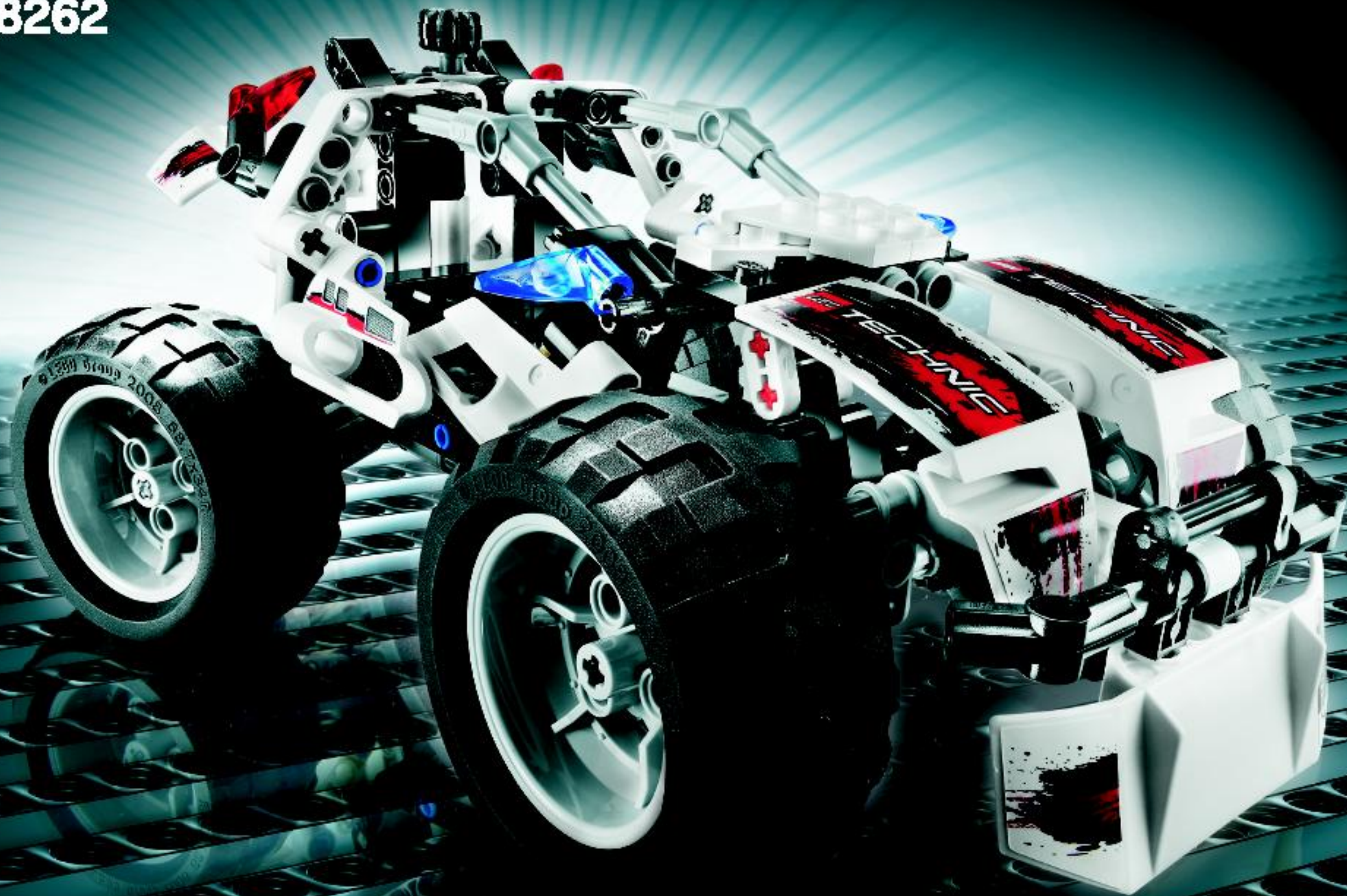

TECHNIC

8262

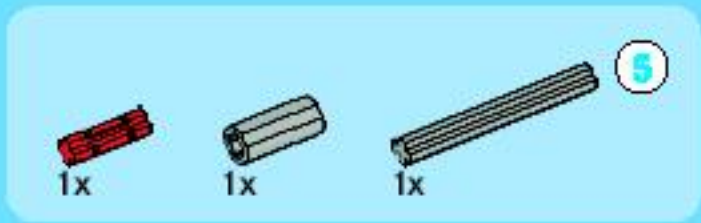

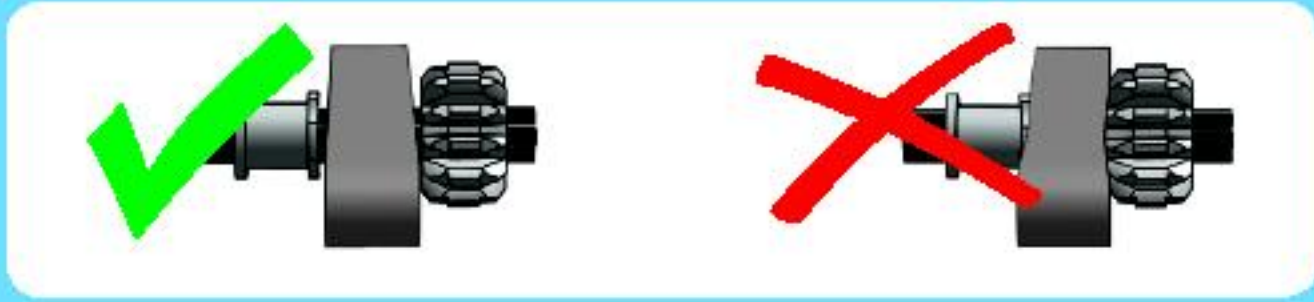
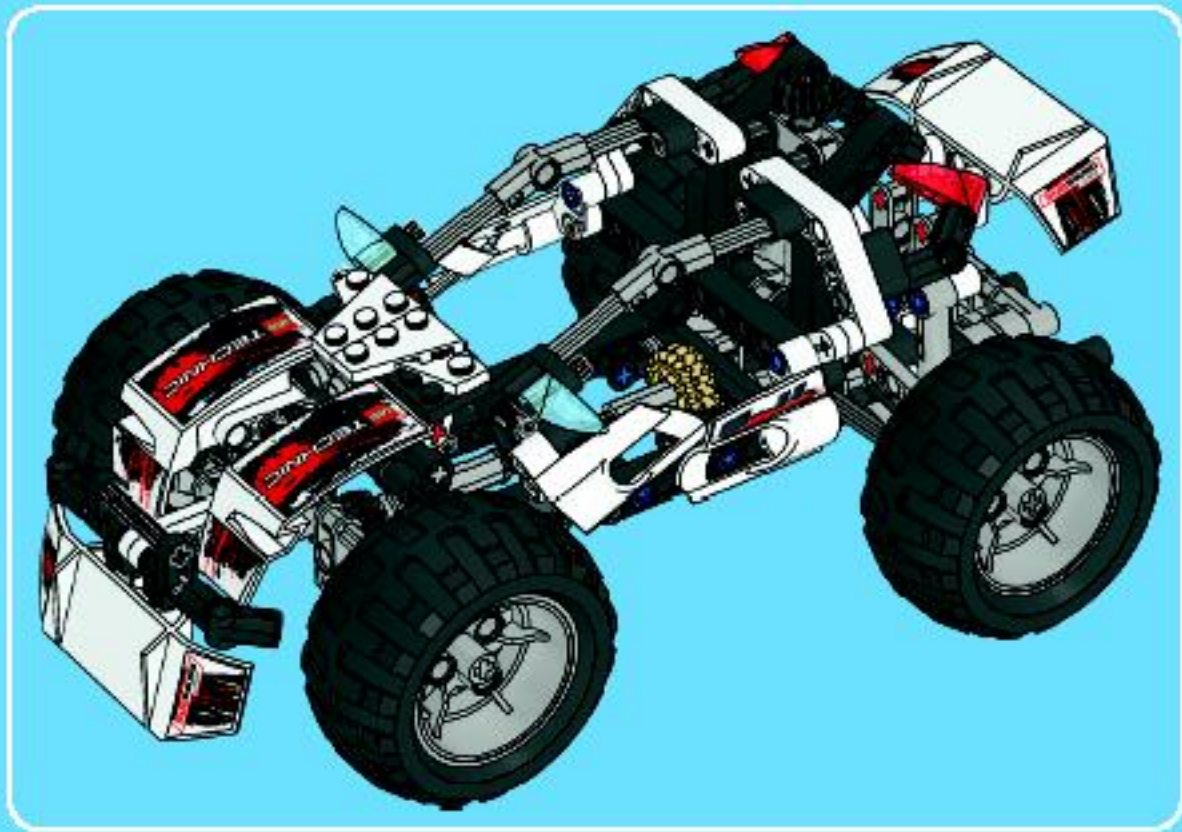

1

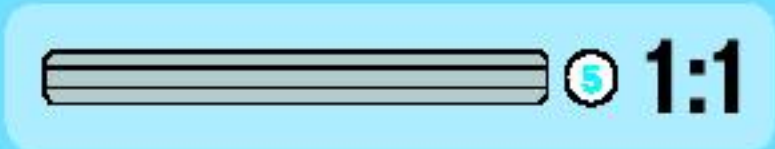
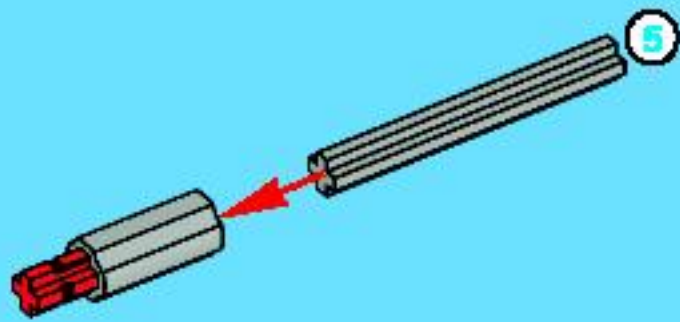

2



2

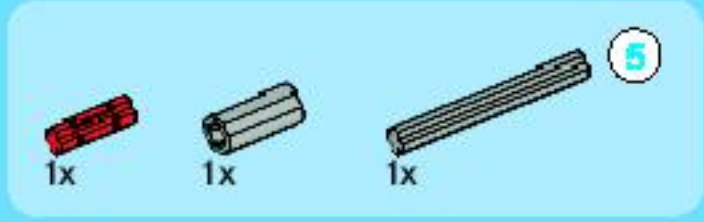
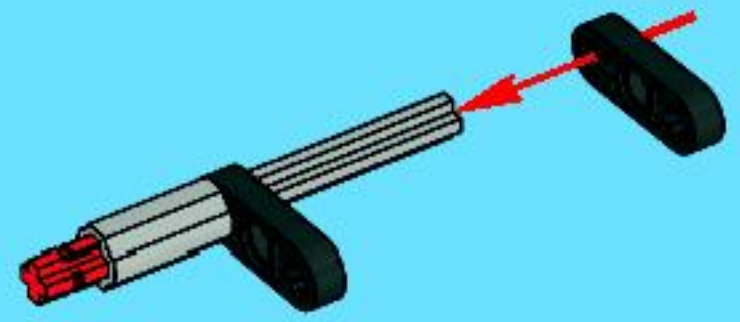

3

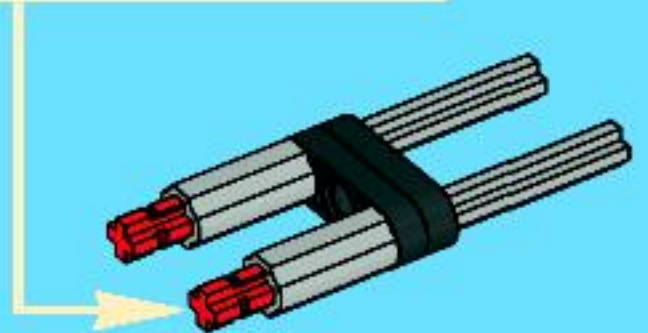
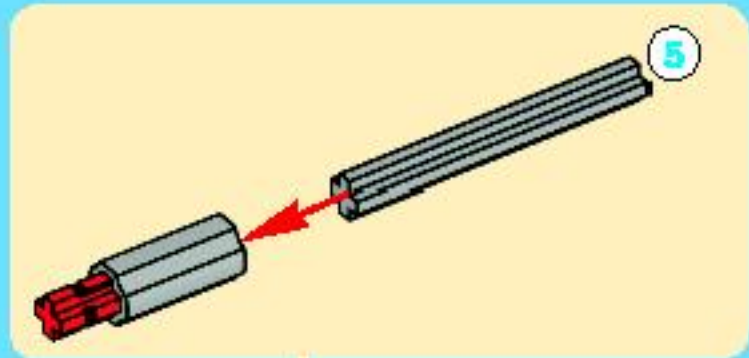

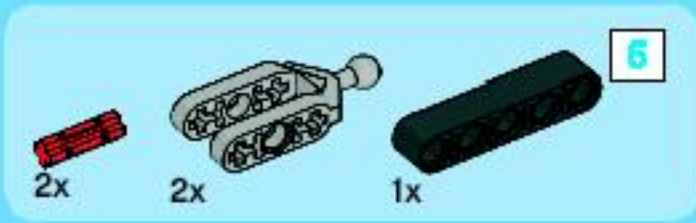

4

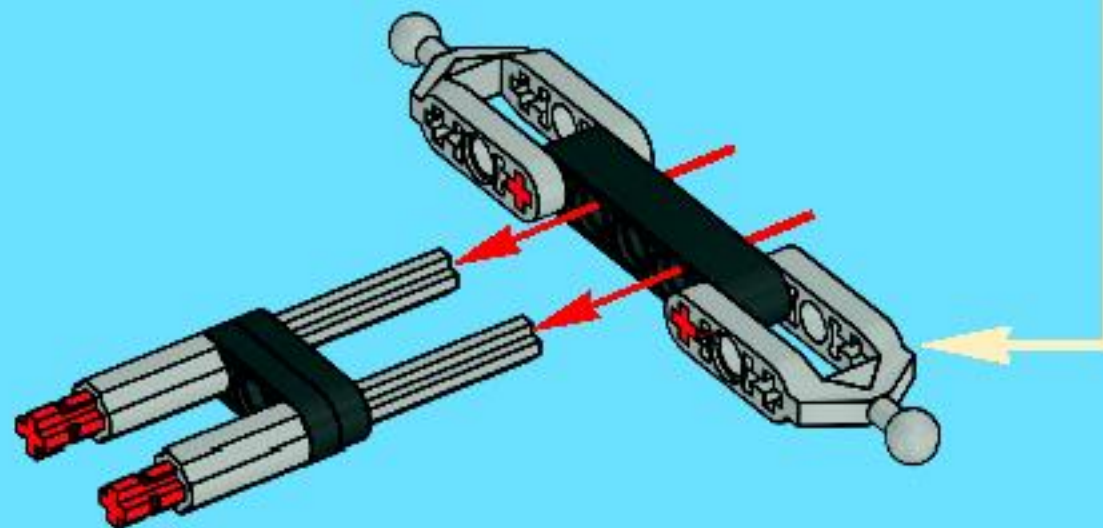
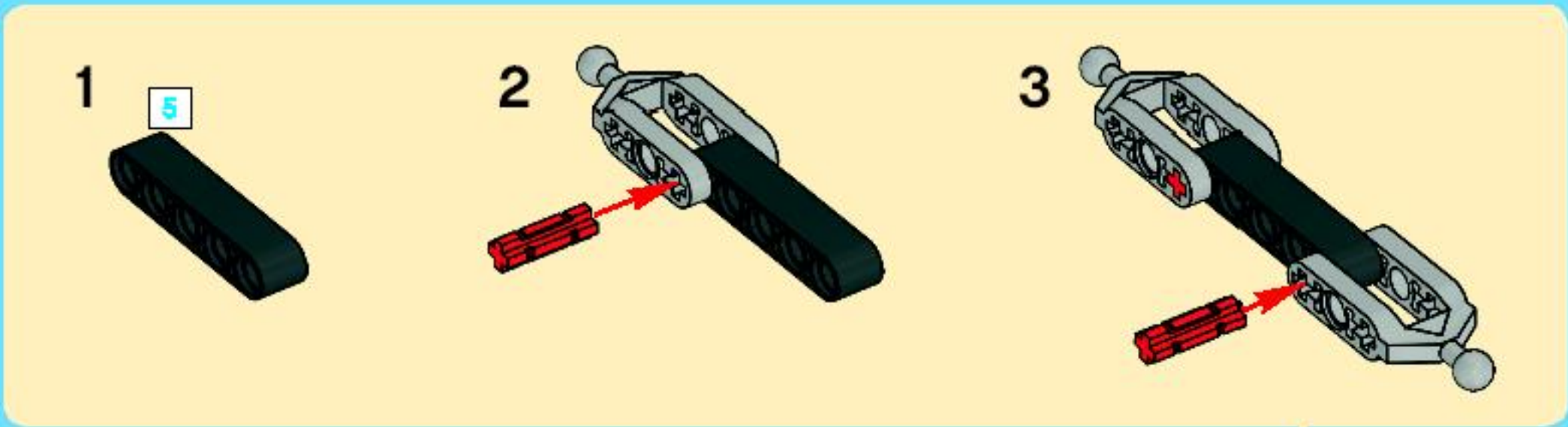

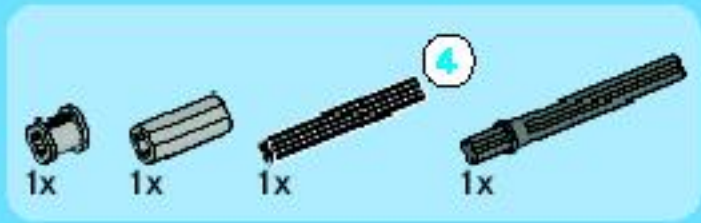

5

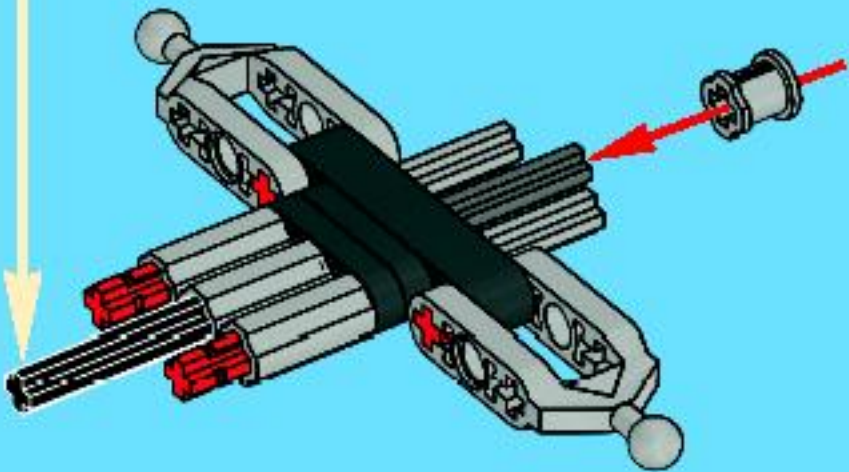
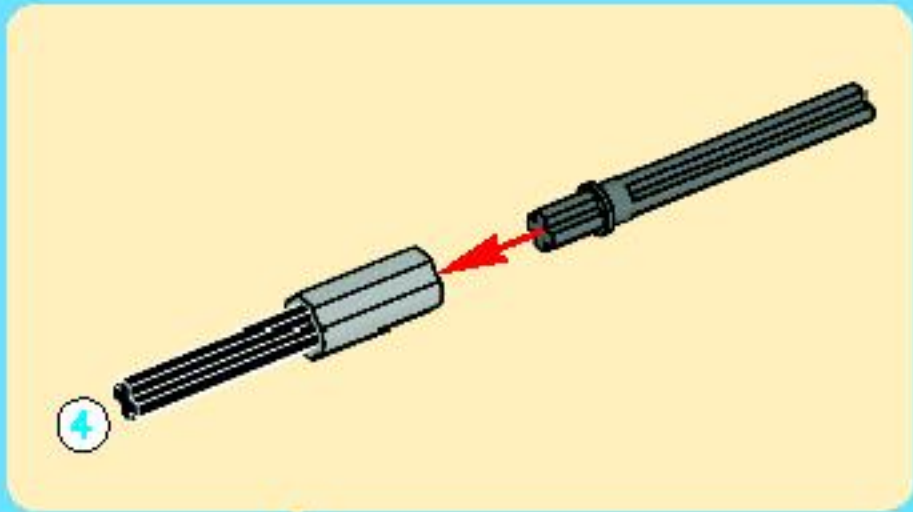

6

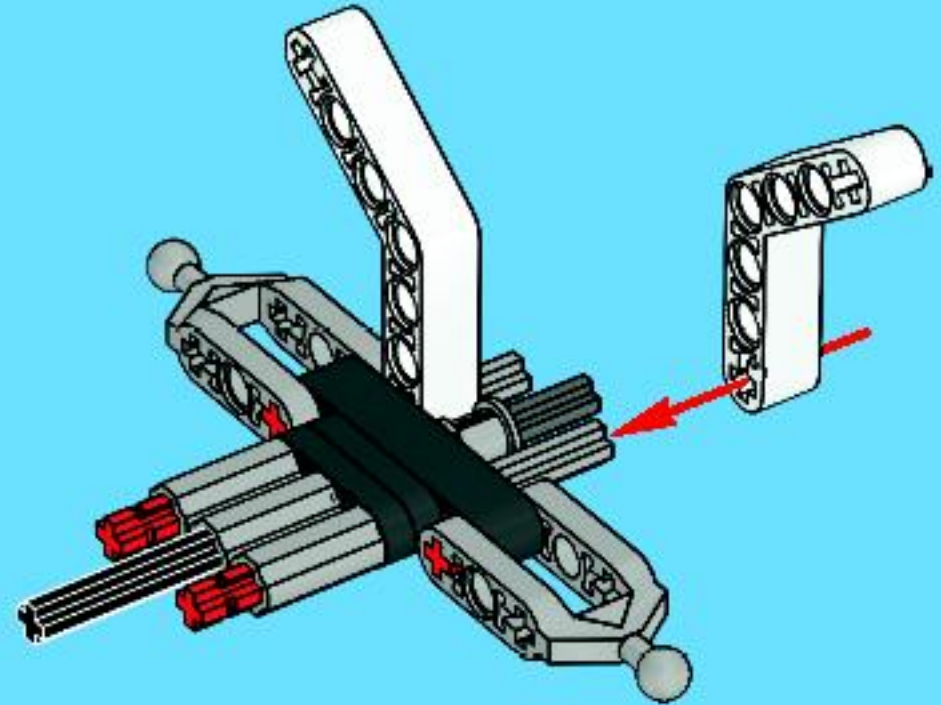

7

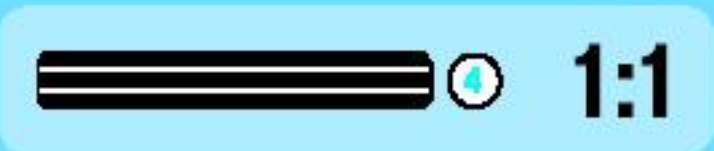
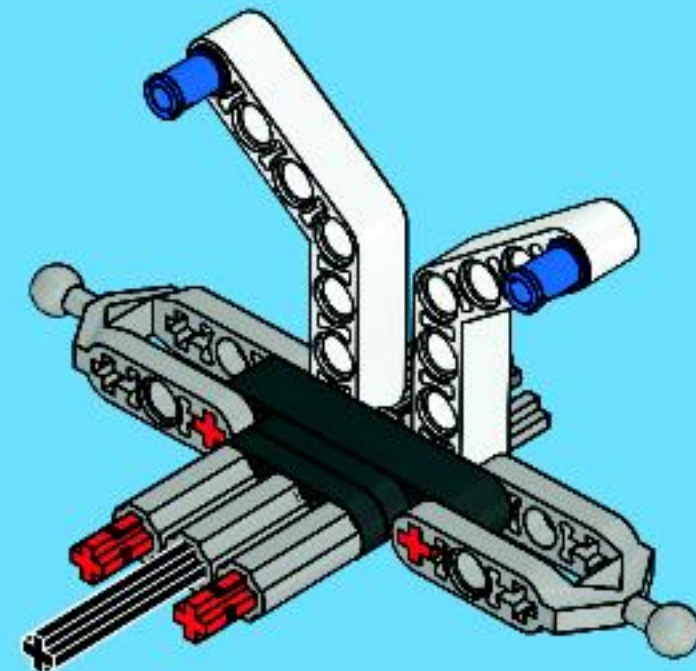



8

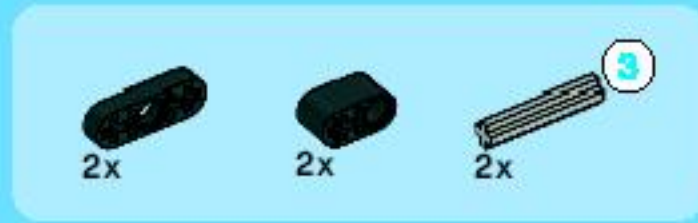
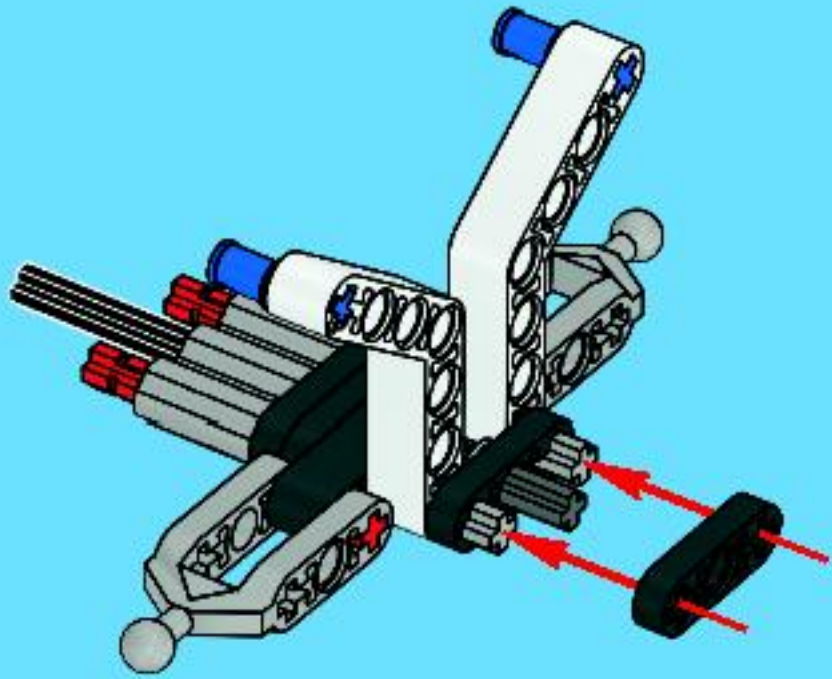

9

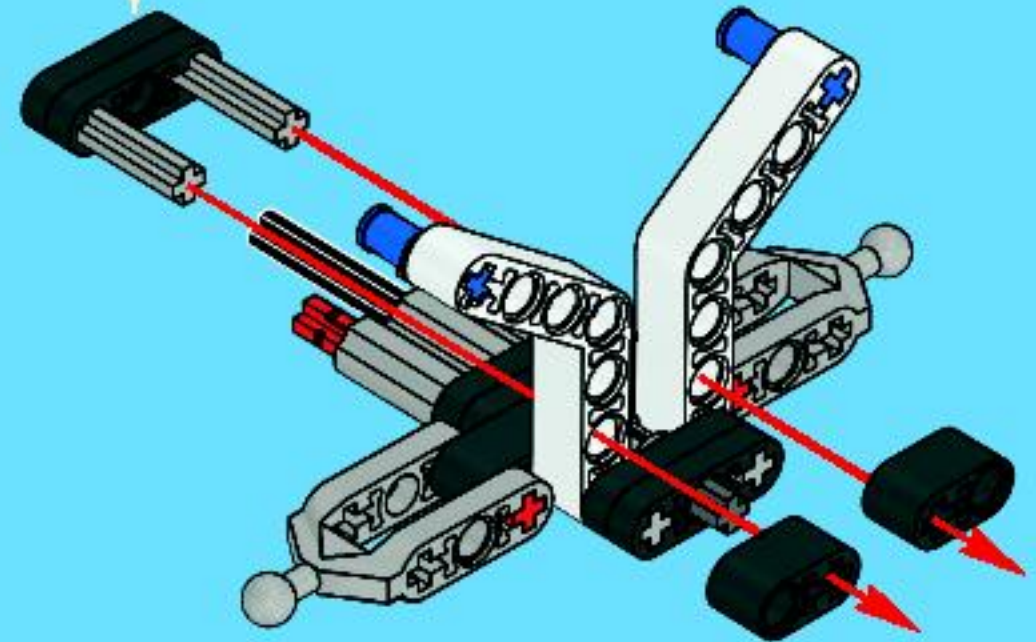
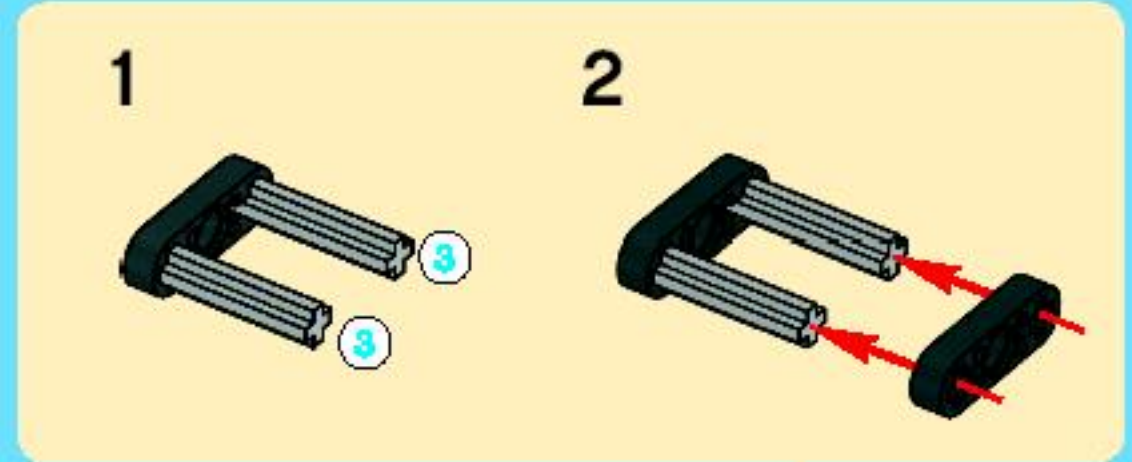

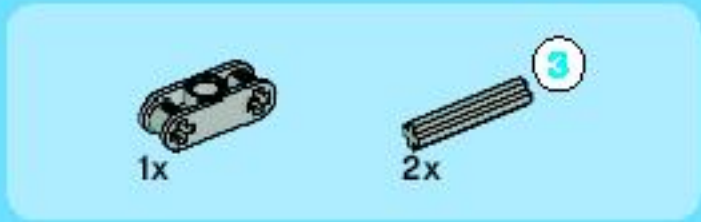
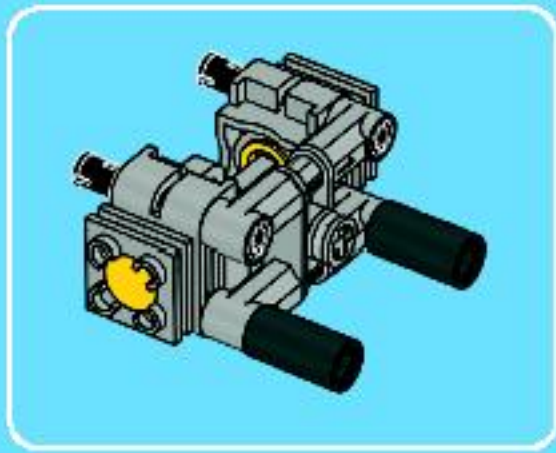

1

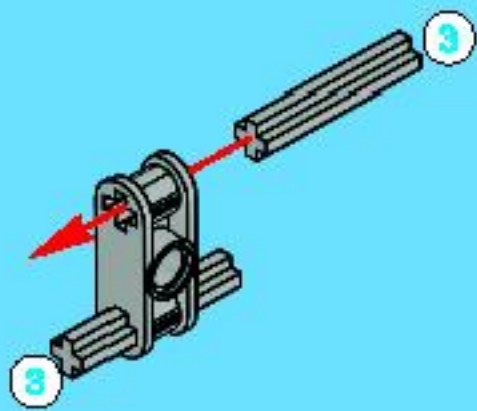

2

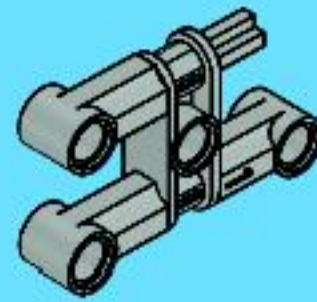

3

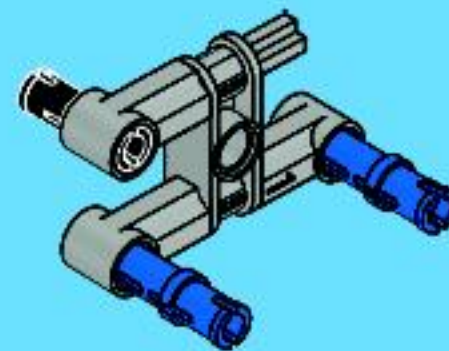



4

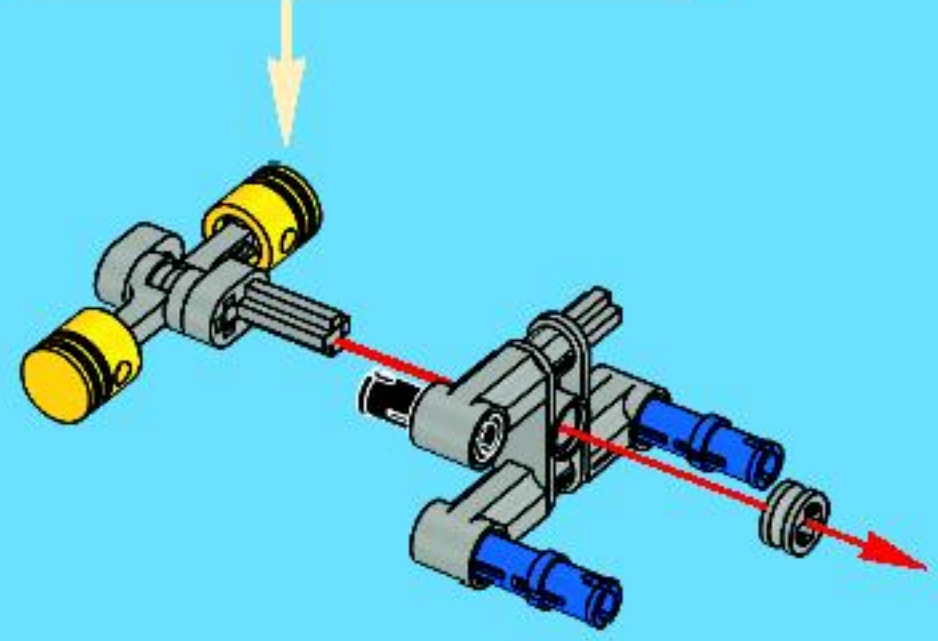
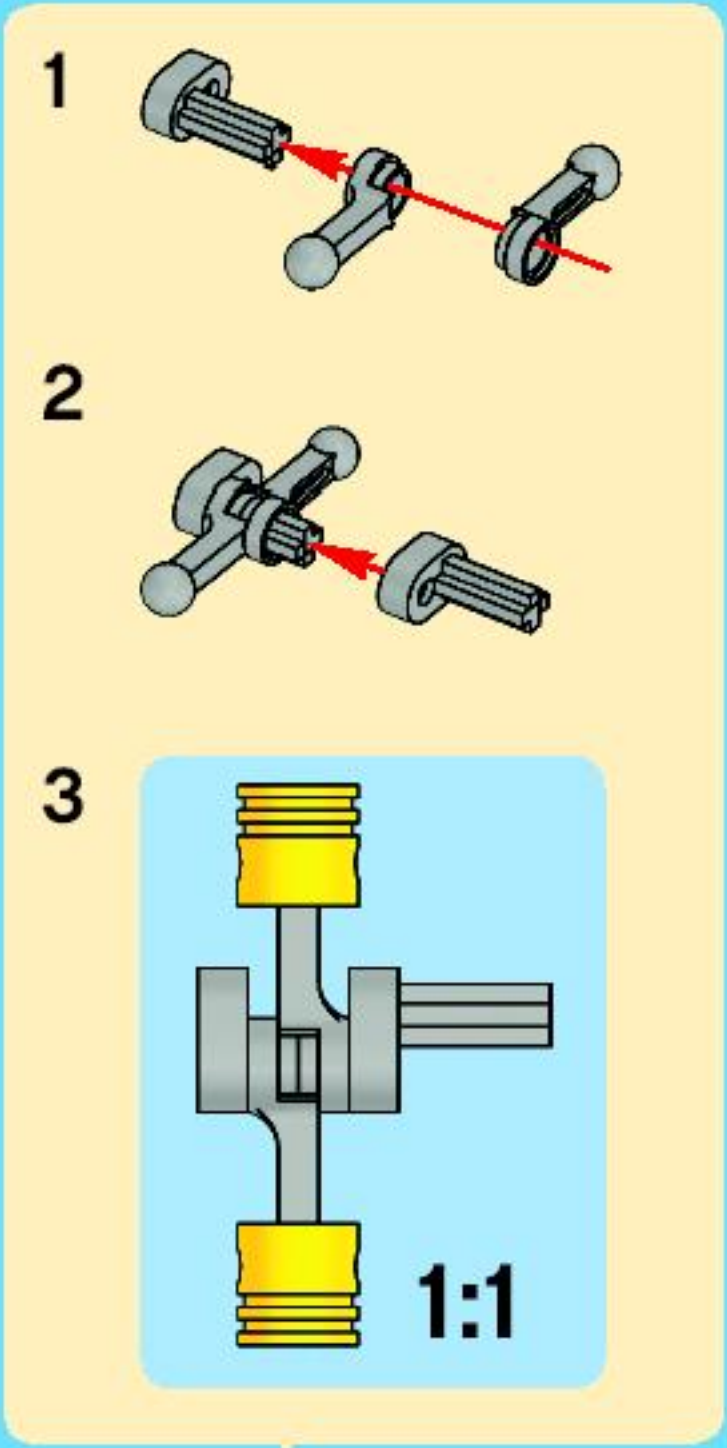

5

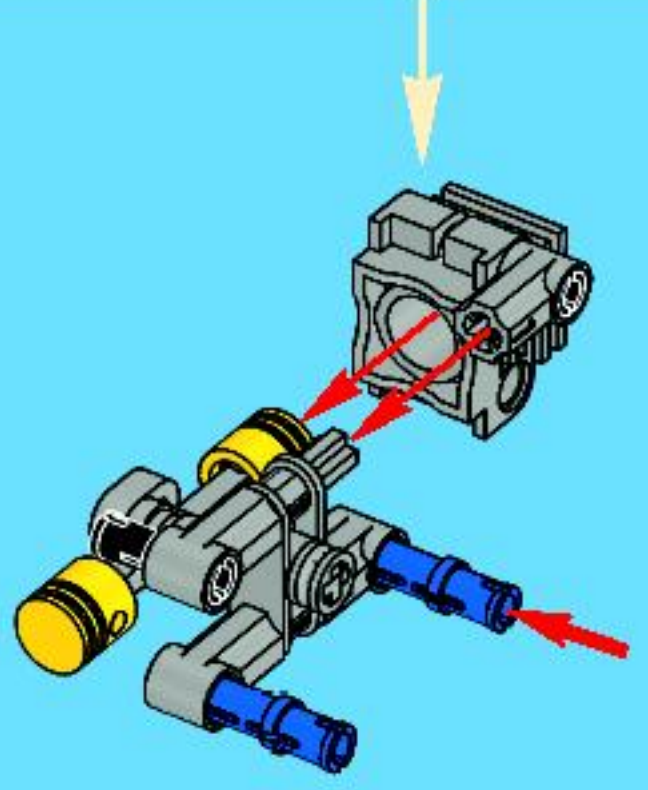
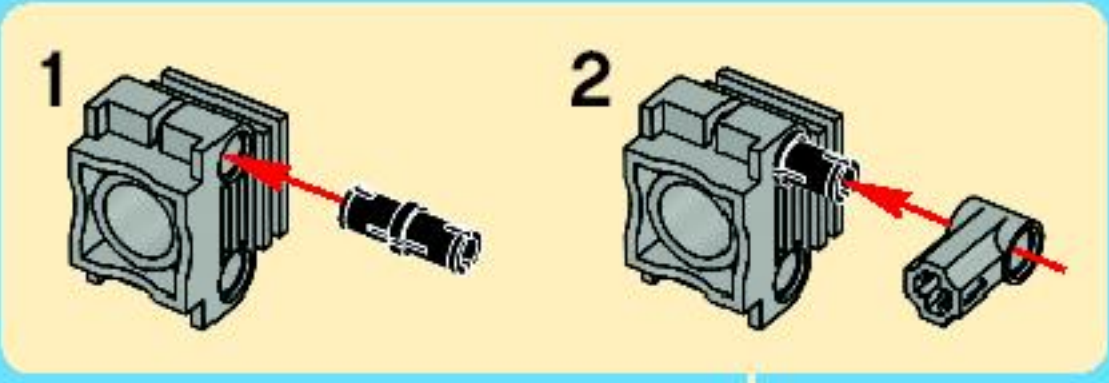

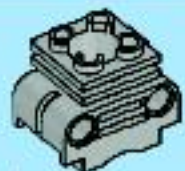

1x

6

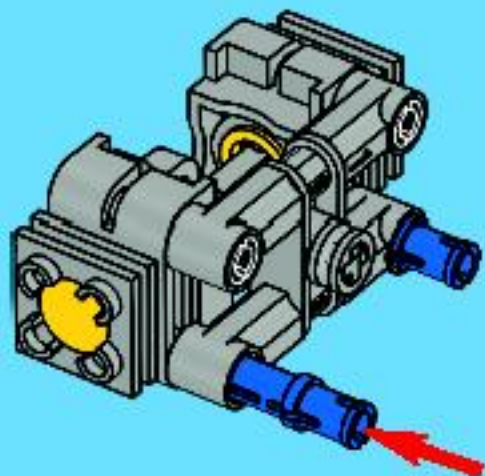

2x

8

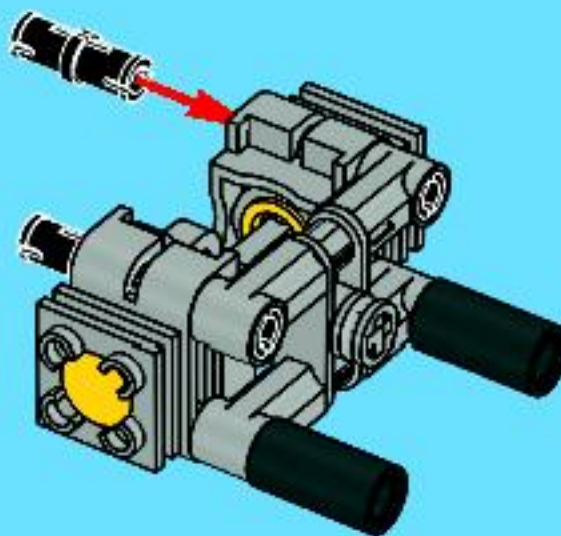

2x

7

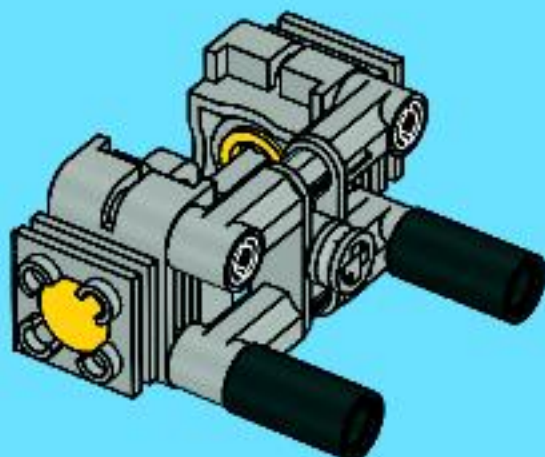

10

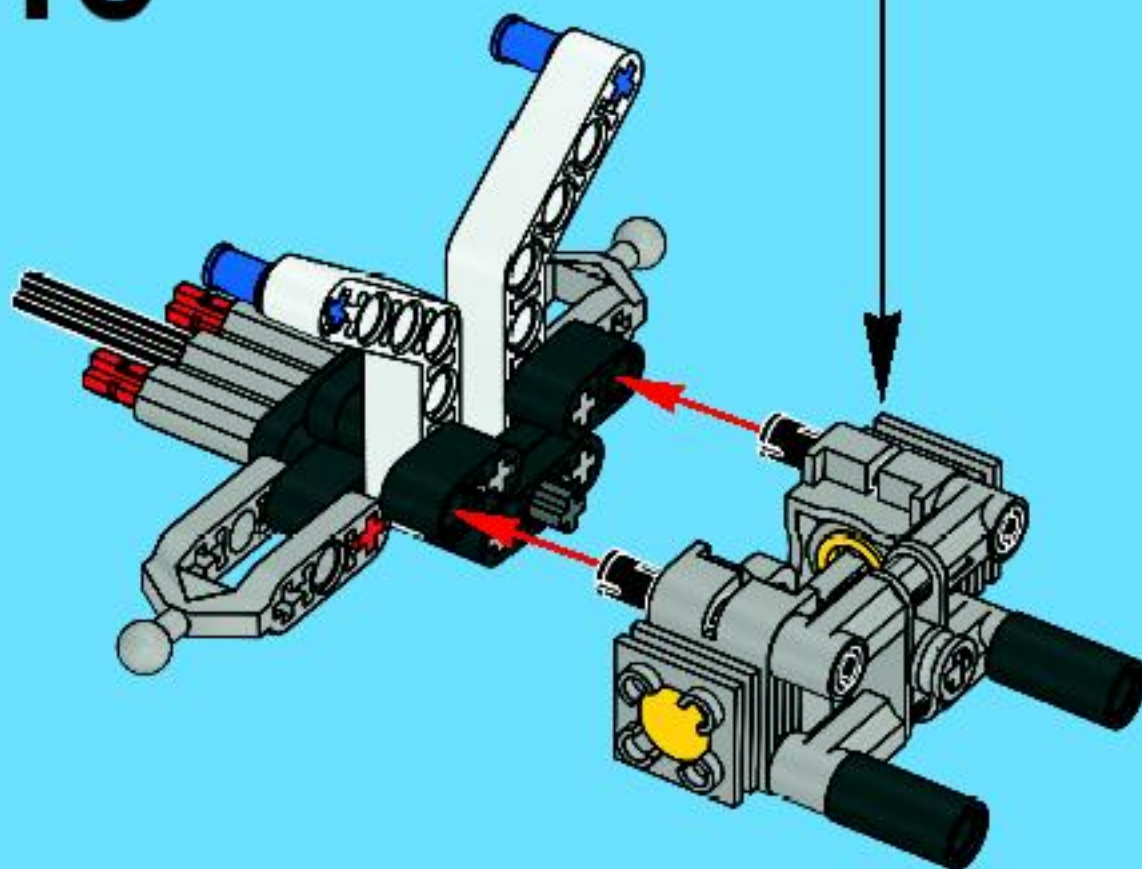

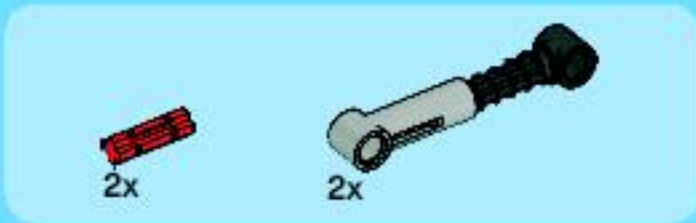

11

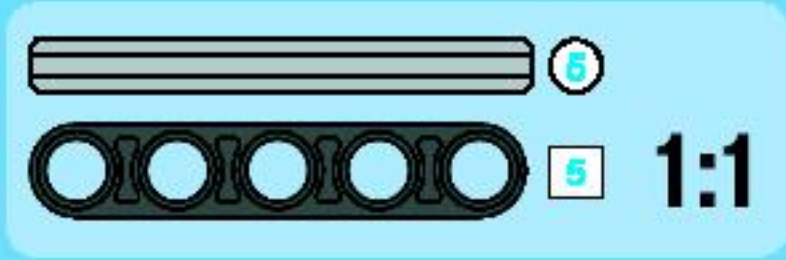
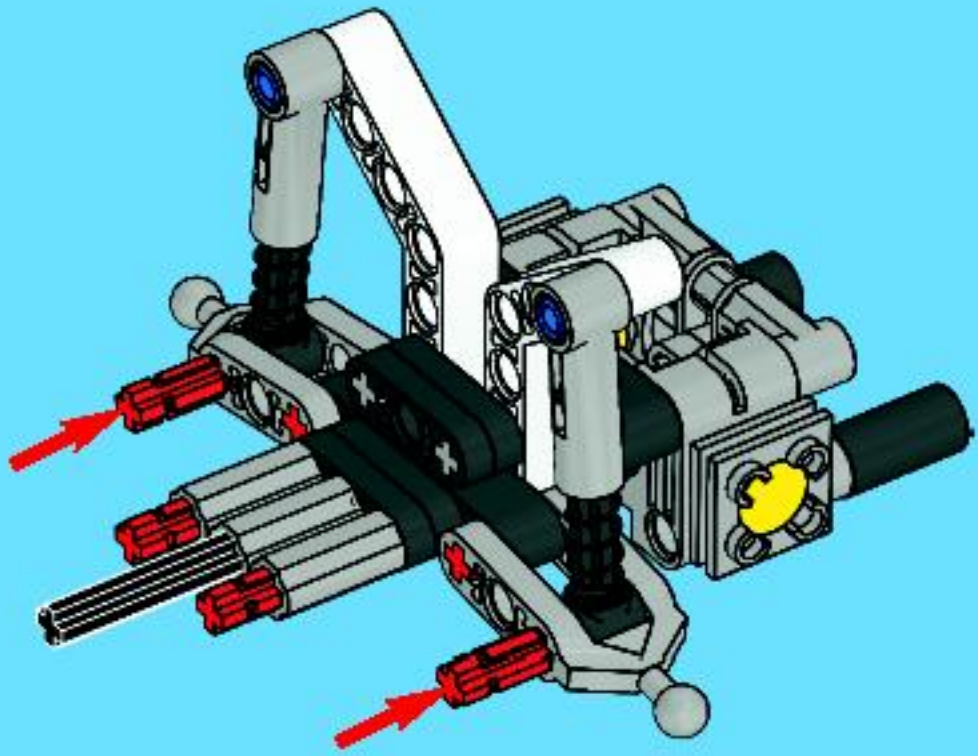

12

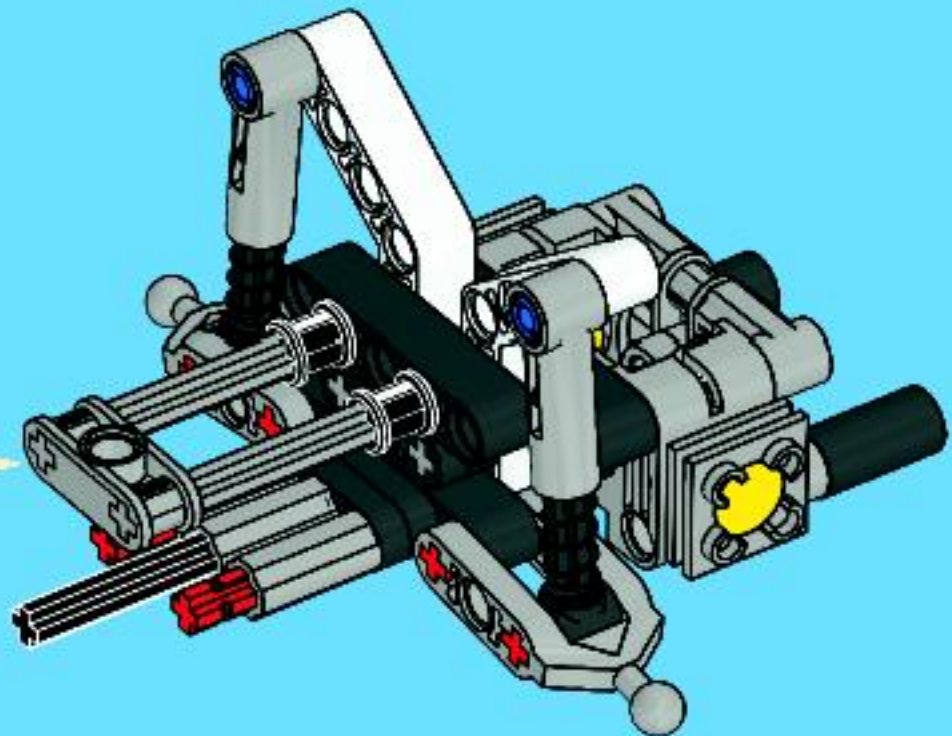
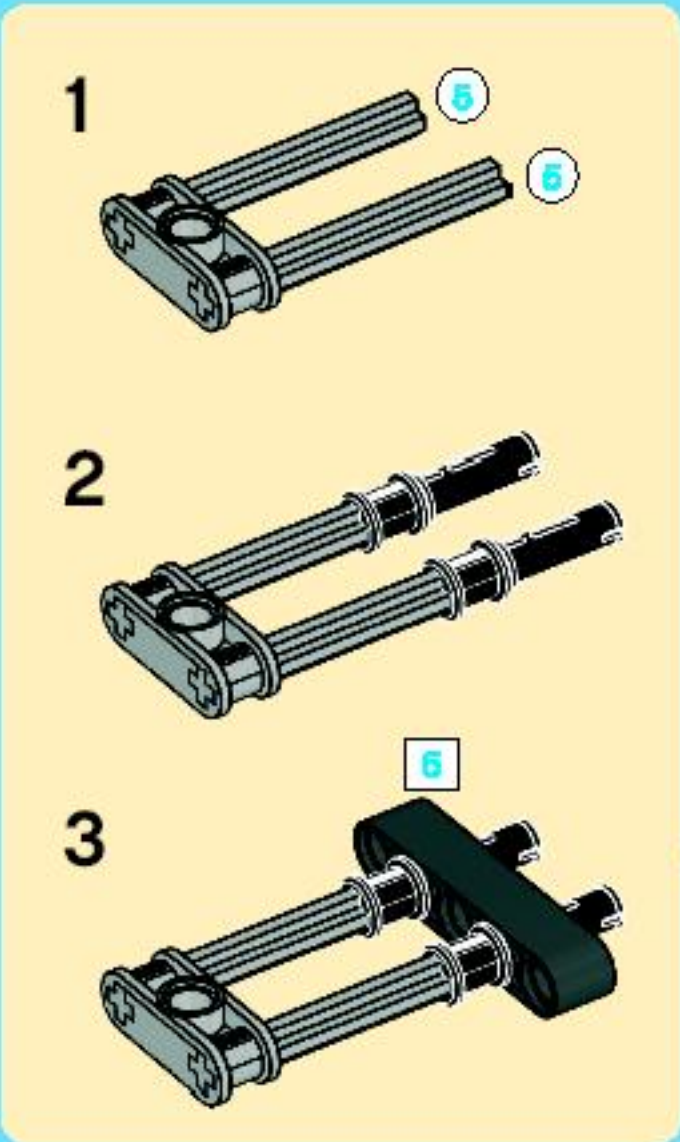

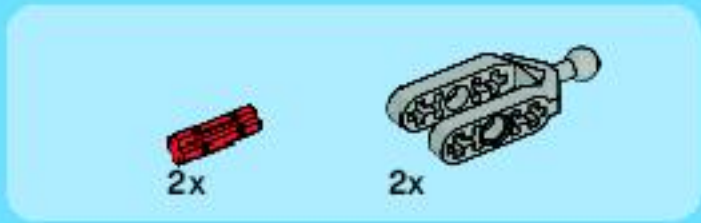

13

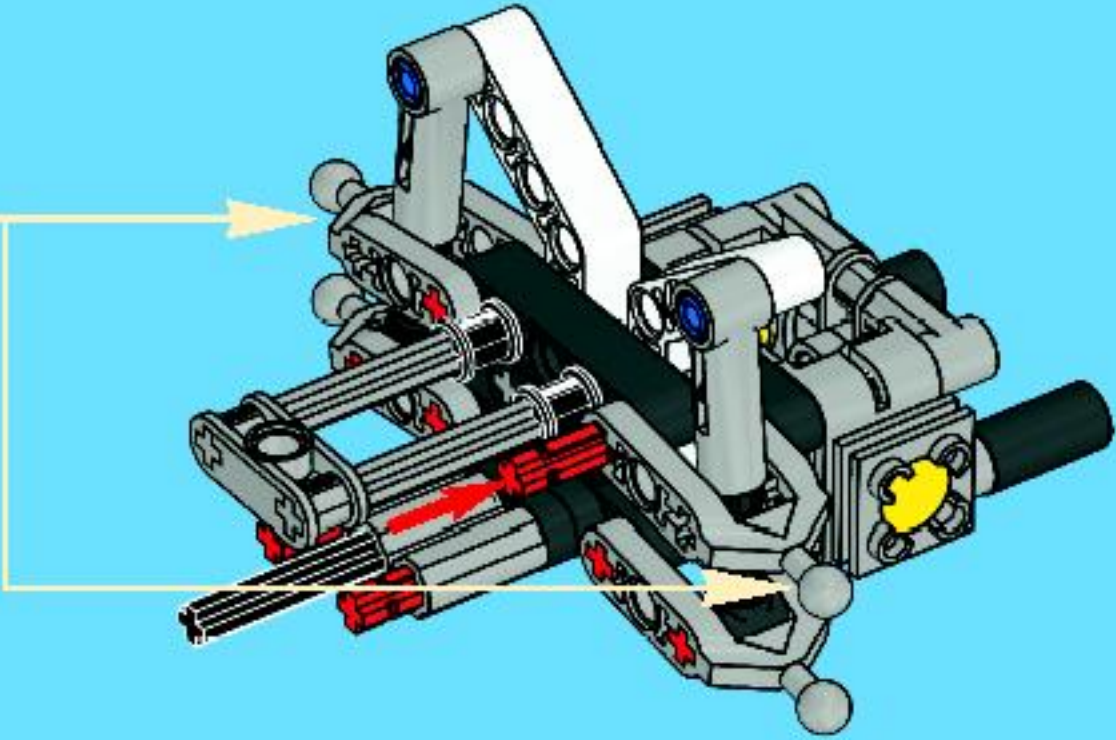
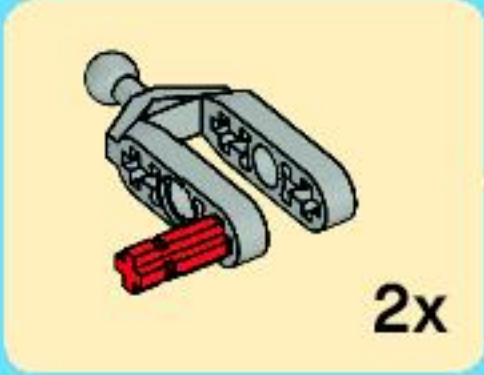

14

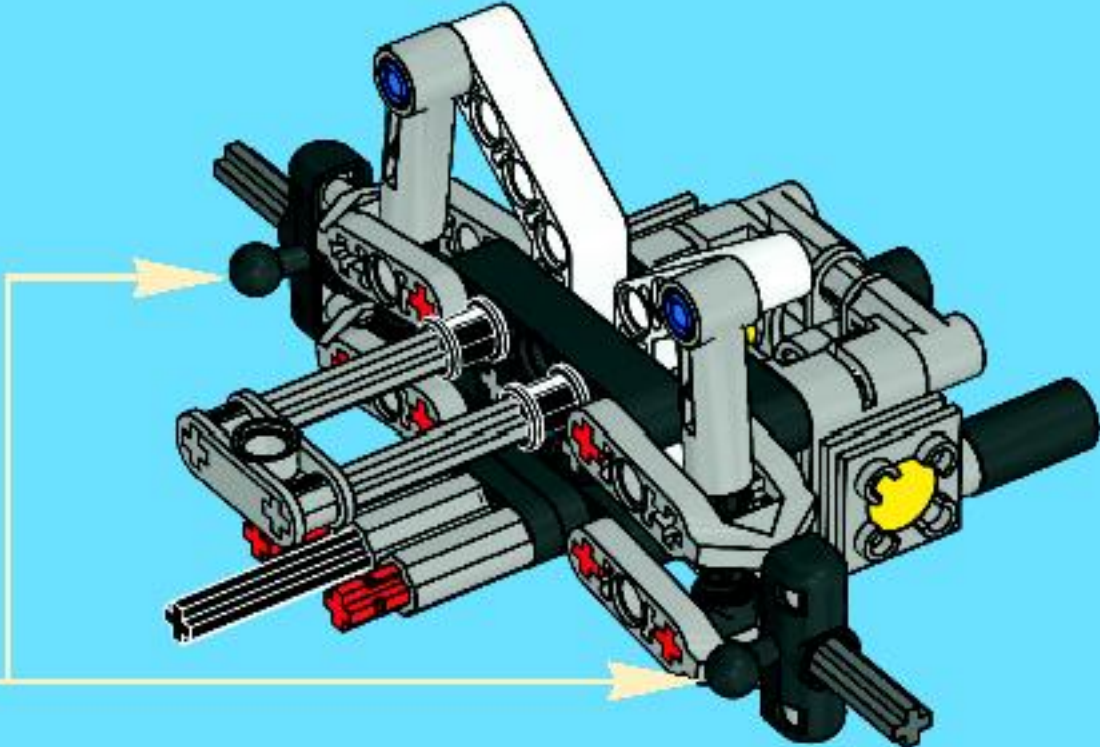



15

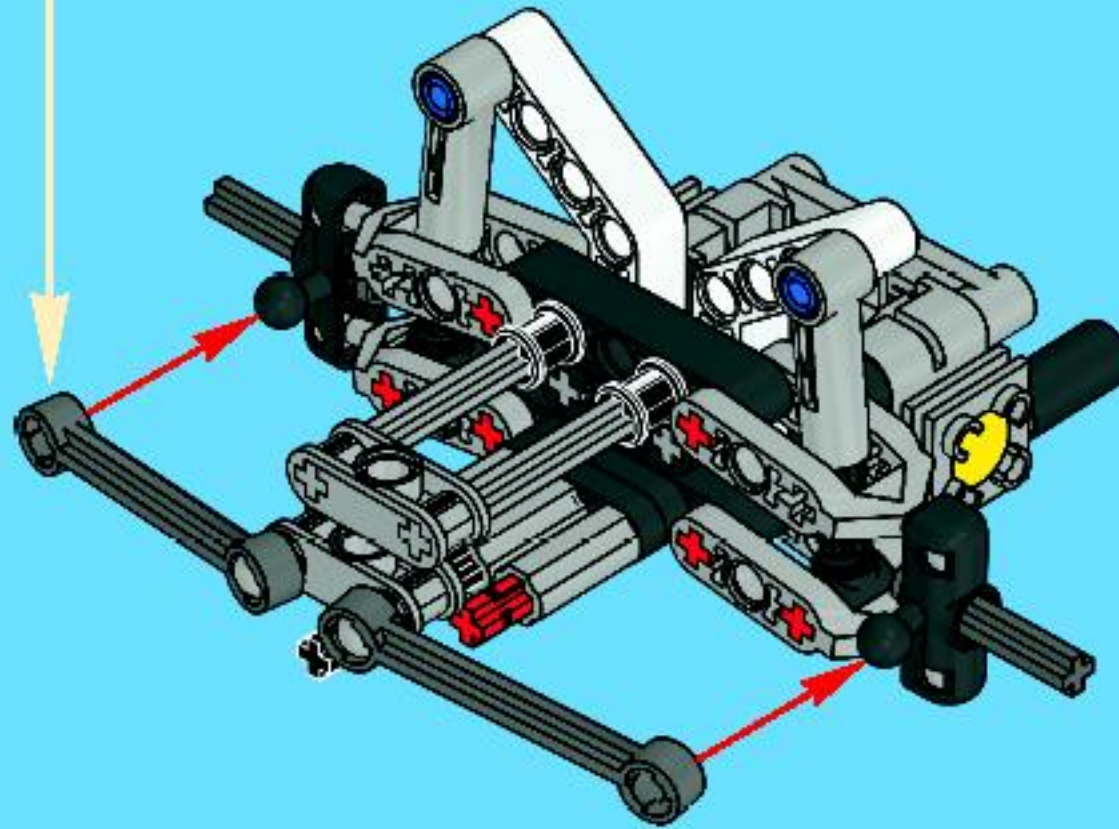
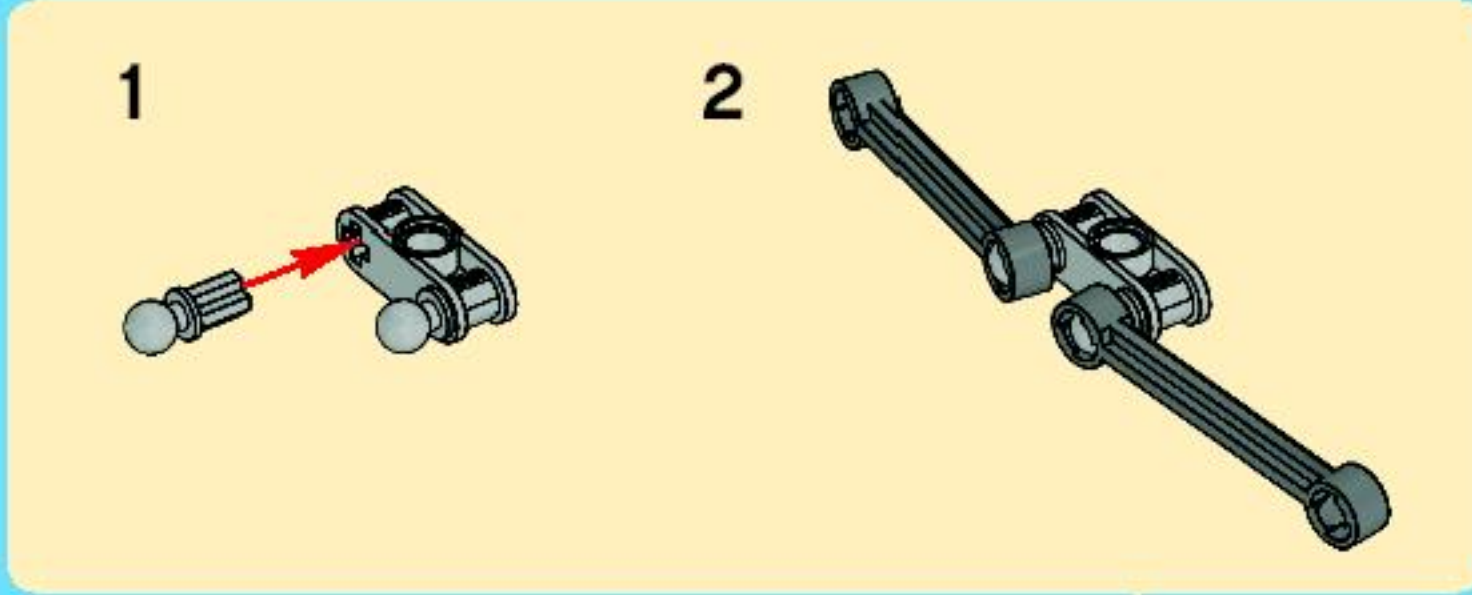

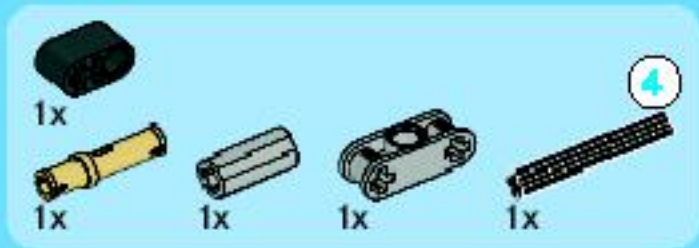

16

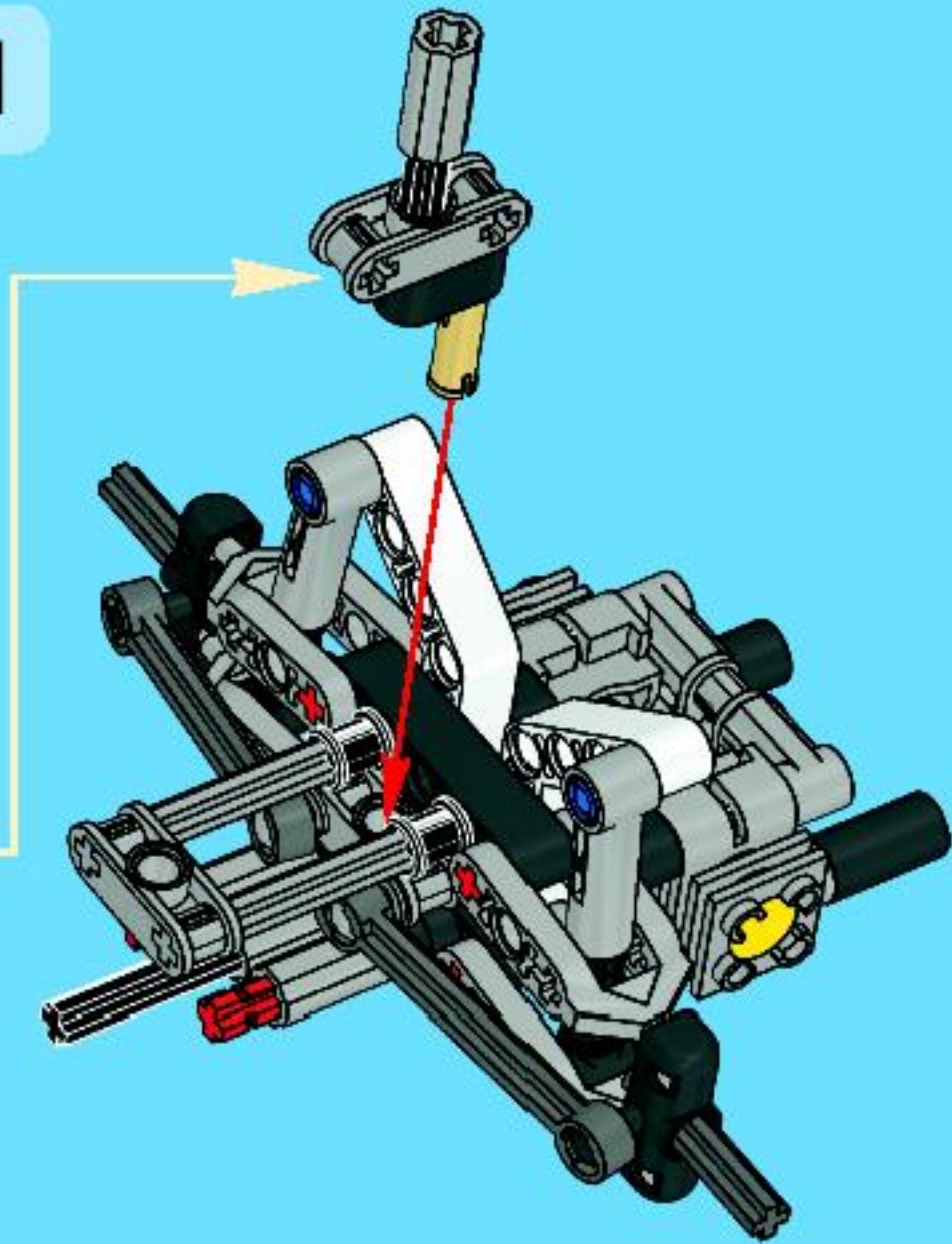
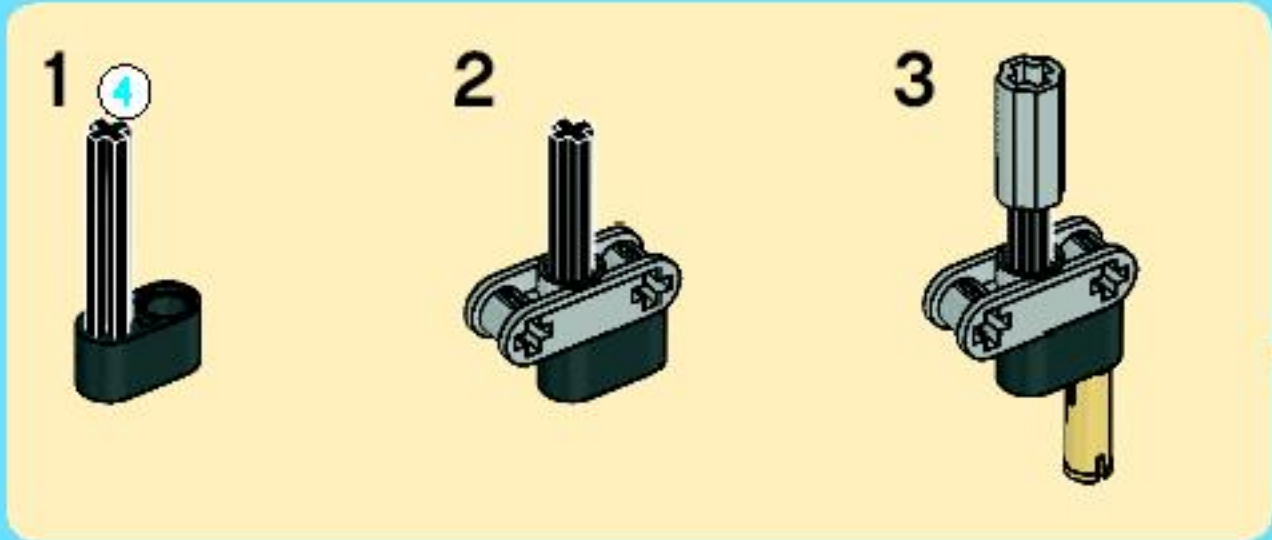

17

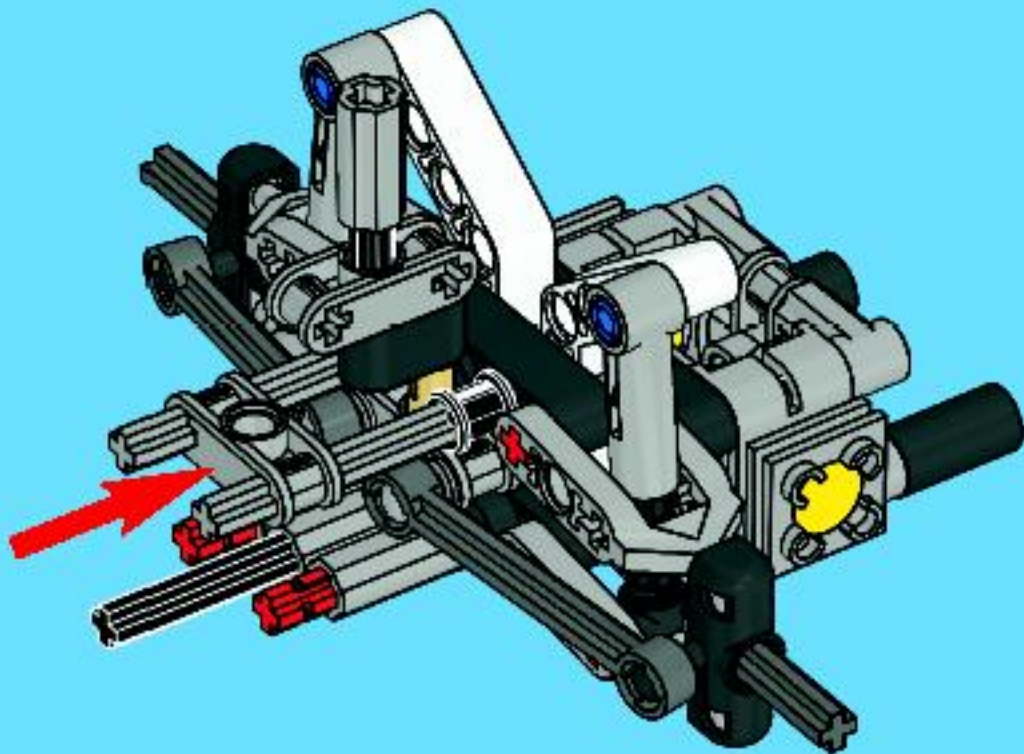



2x

18

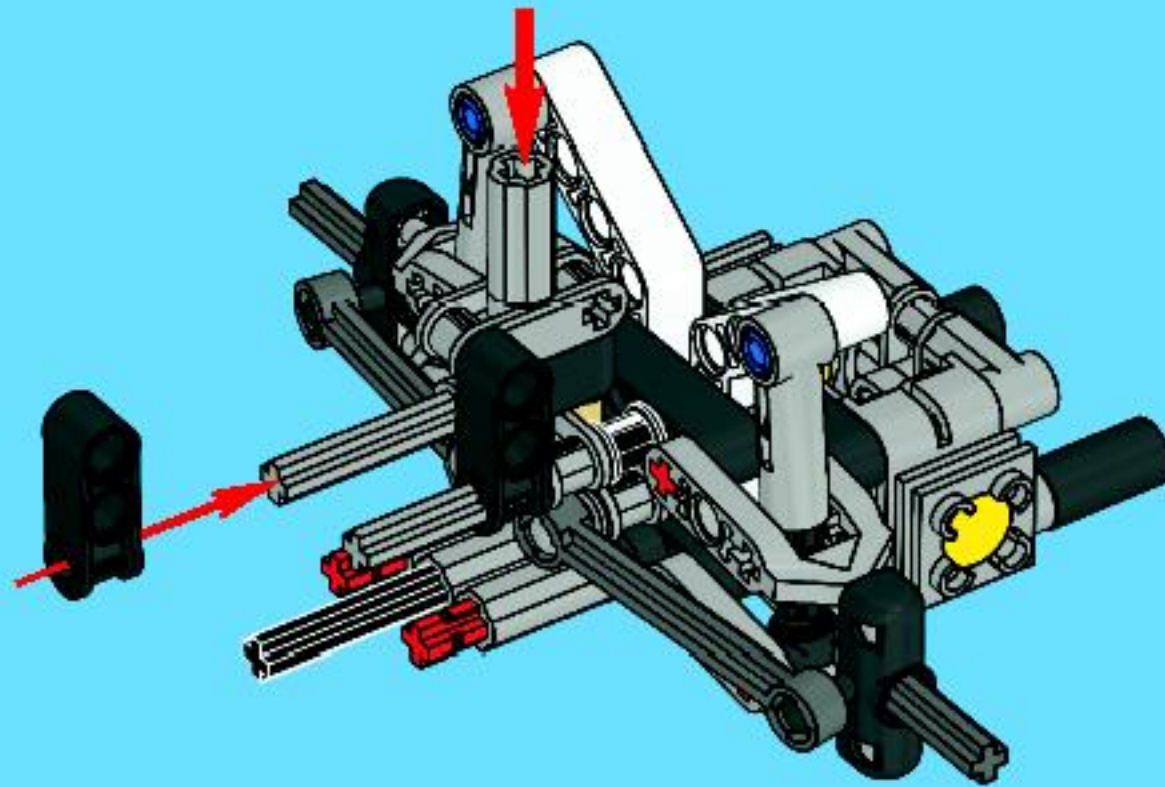

2x

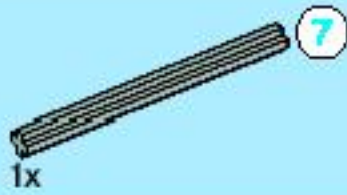

1x



1:1

19

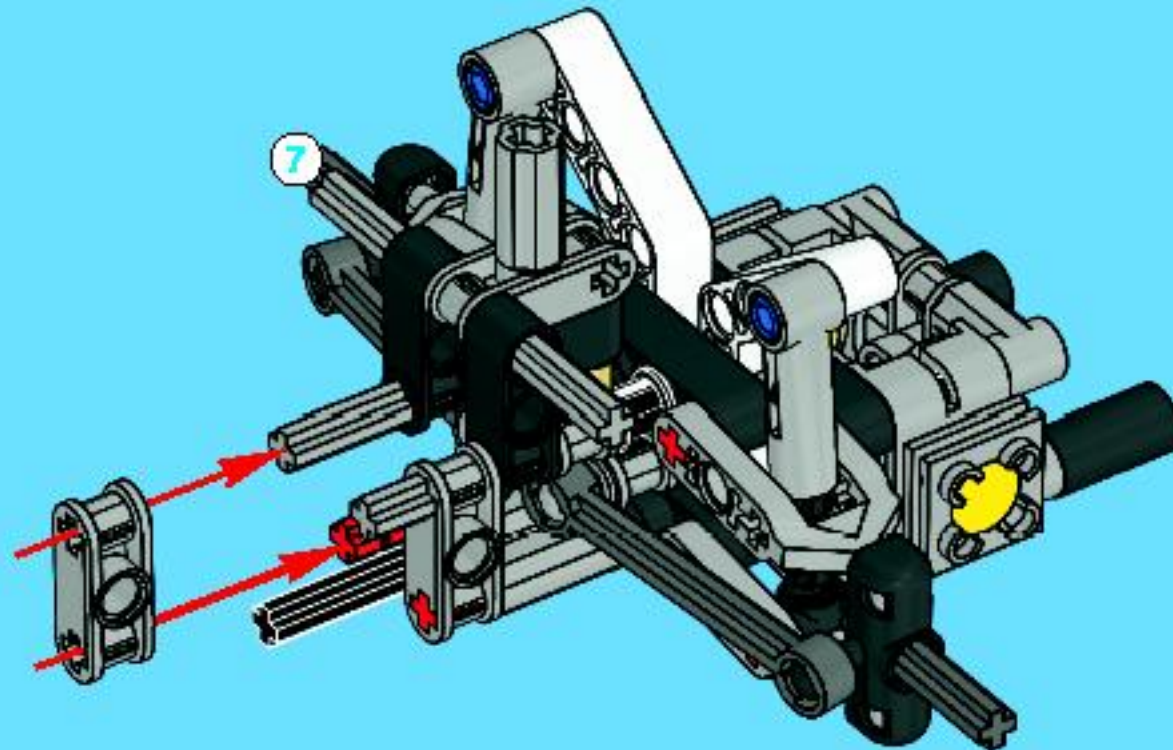

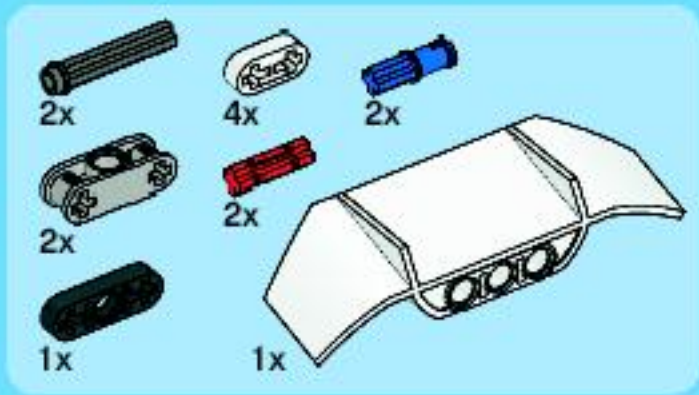

20

1

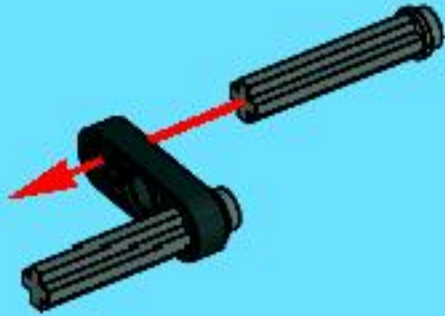

2

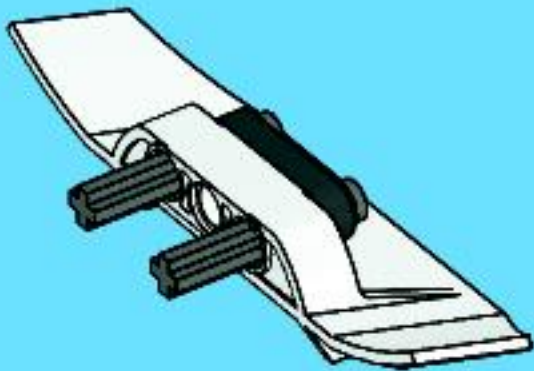

3

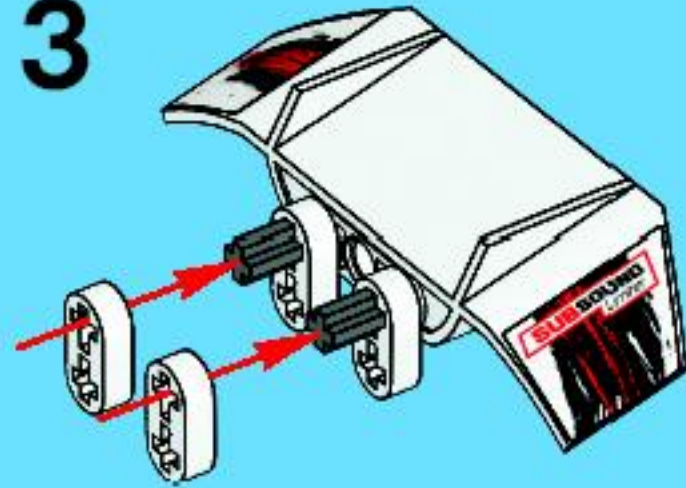

4

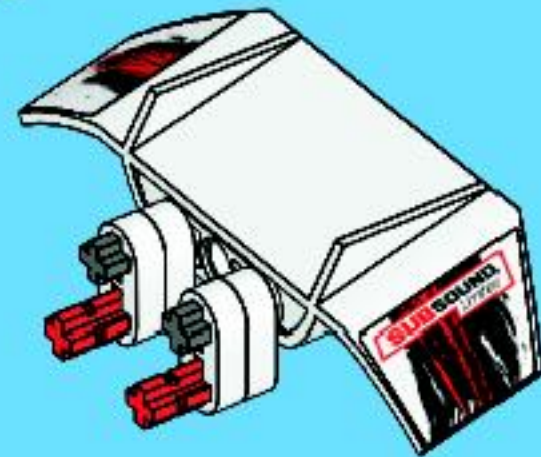

5

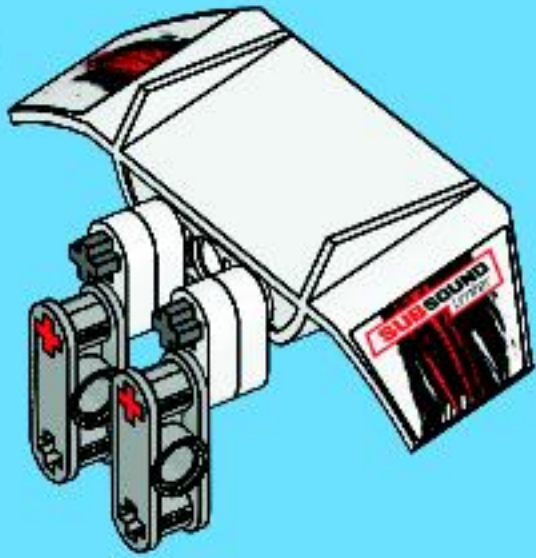

6

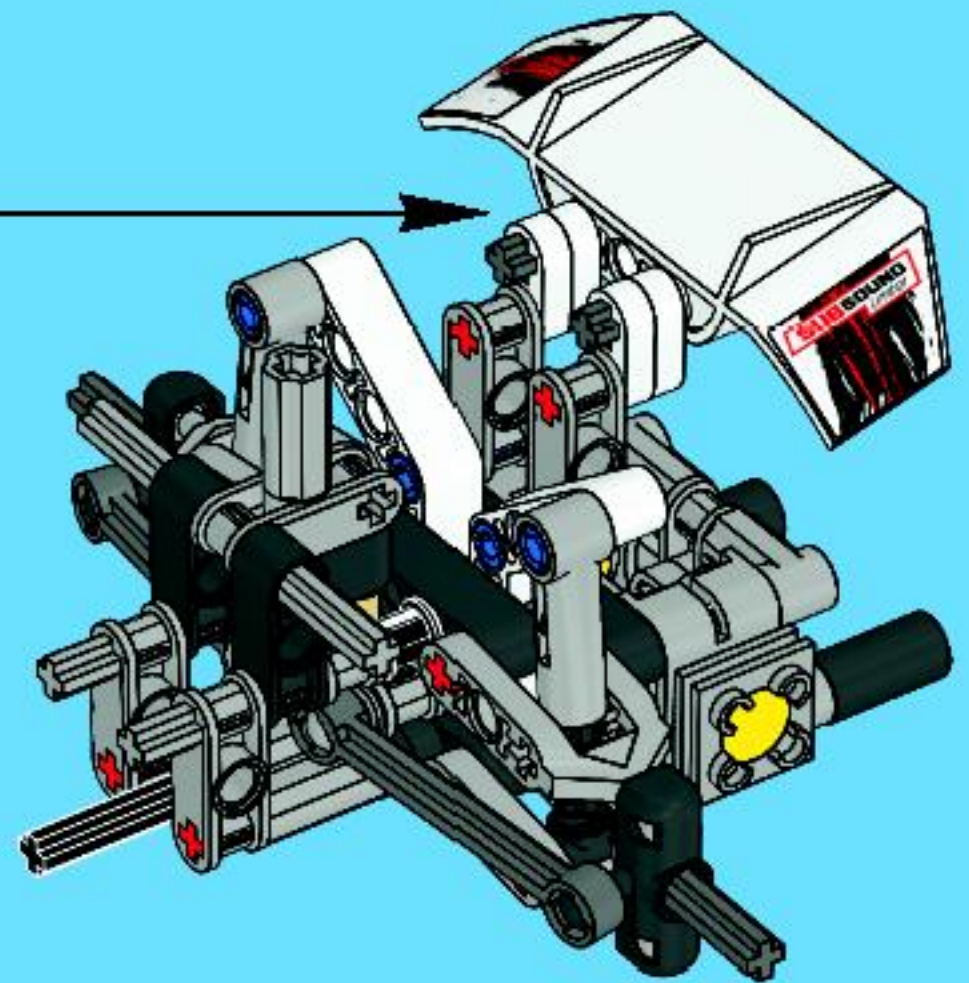
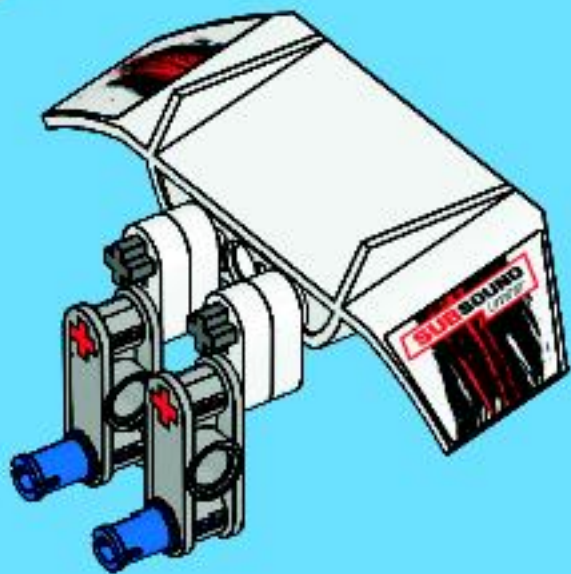

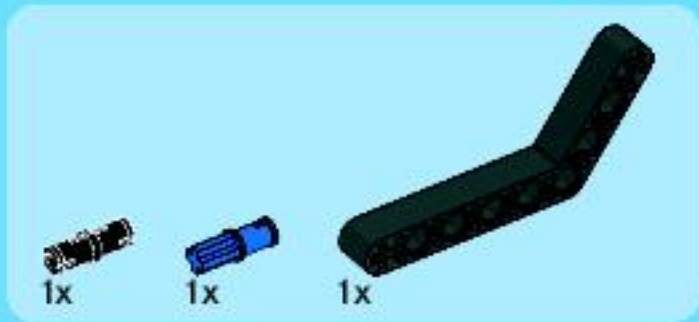

21

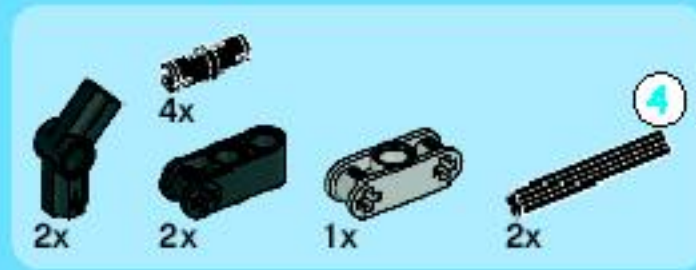
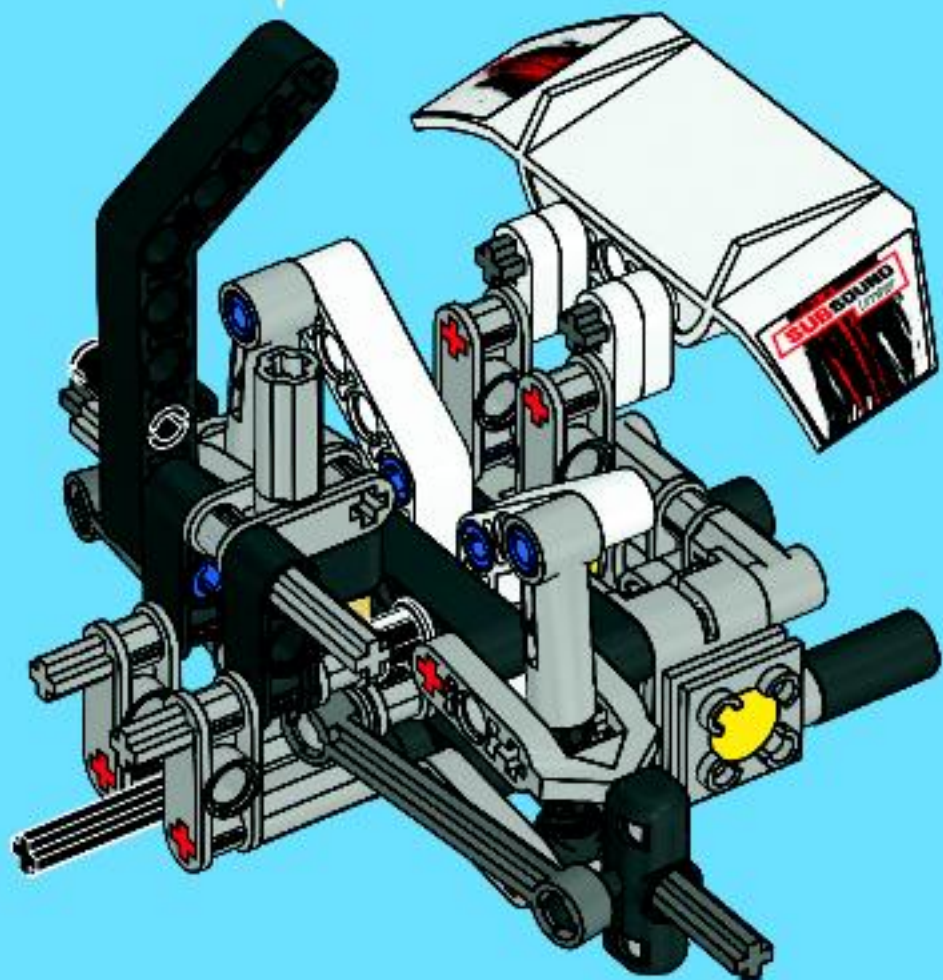
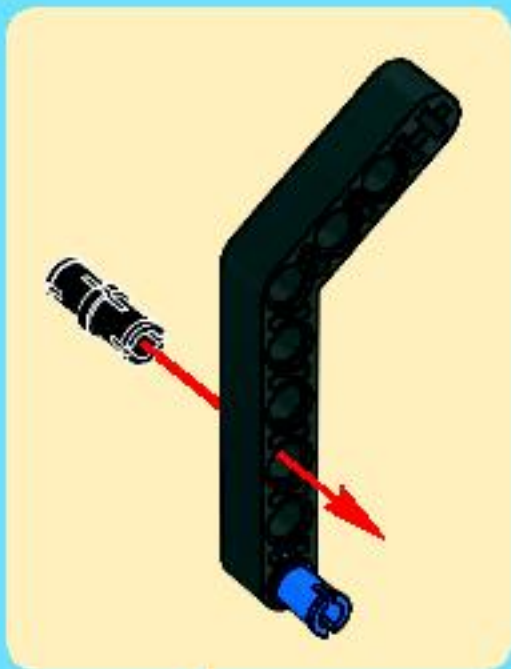

22



1

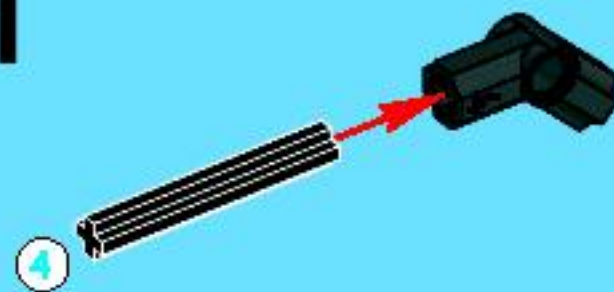

2

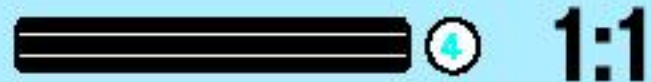

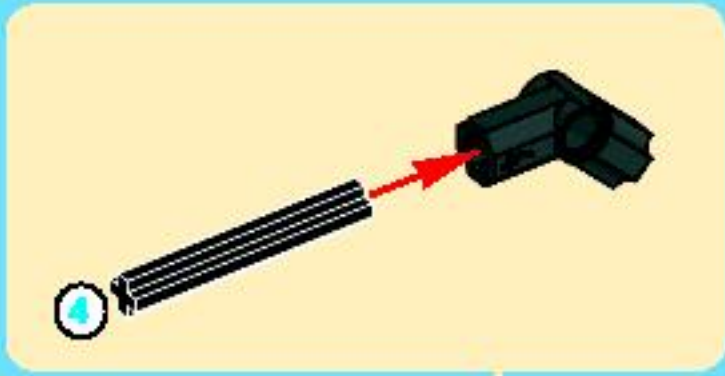

3



4



5

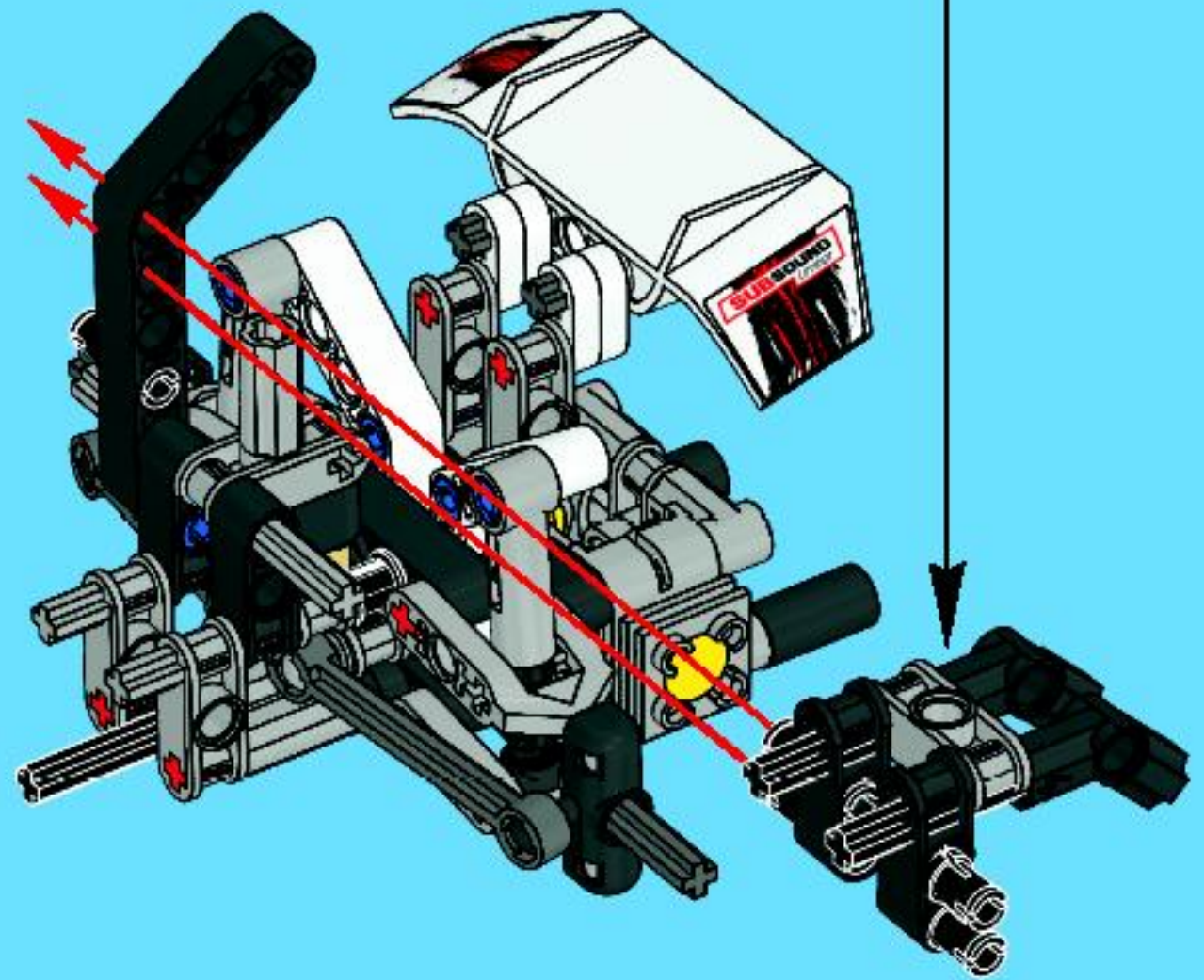
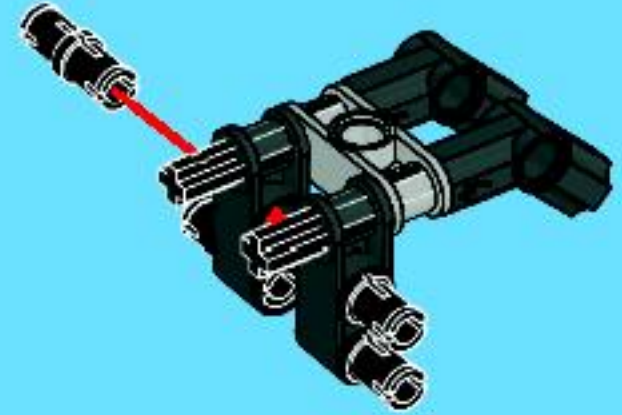

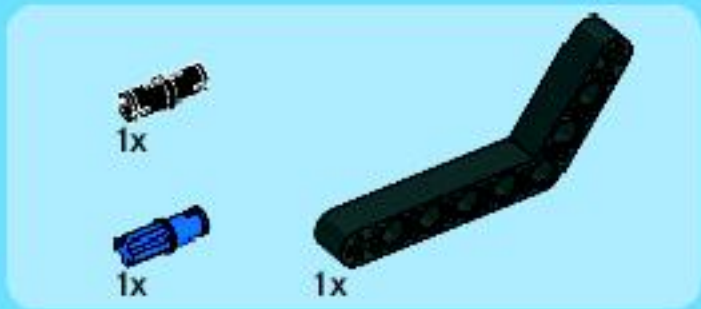

23

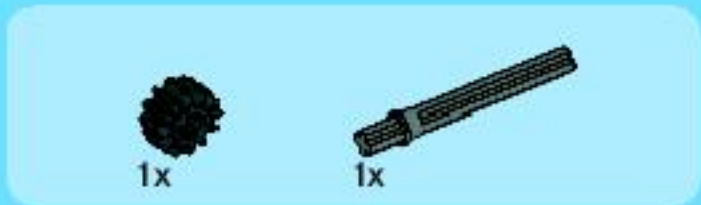
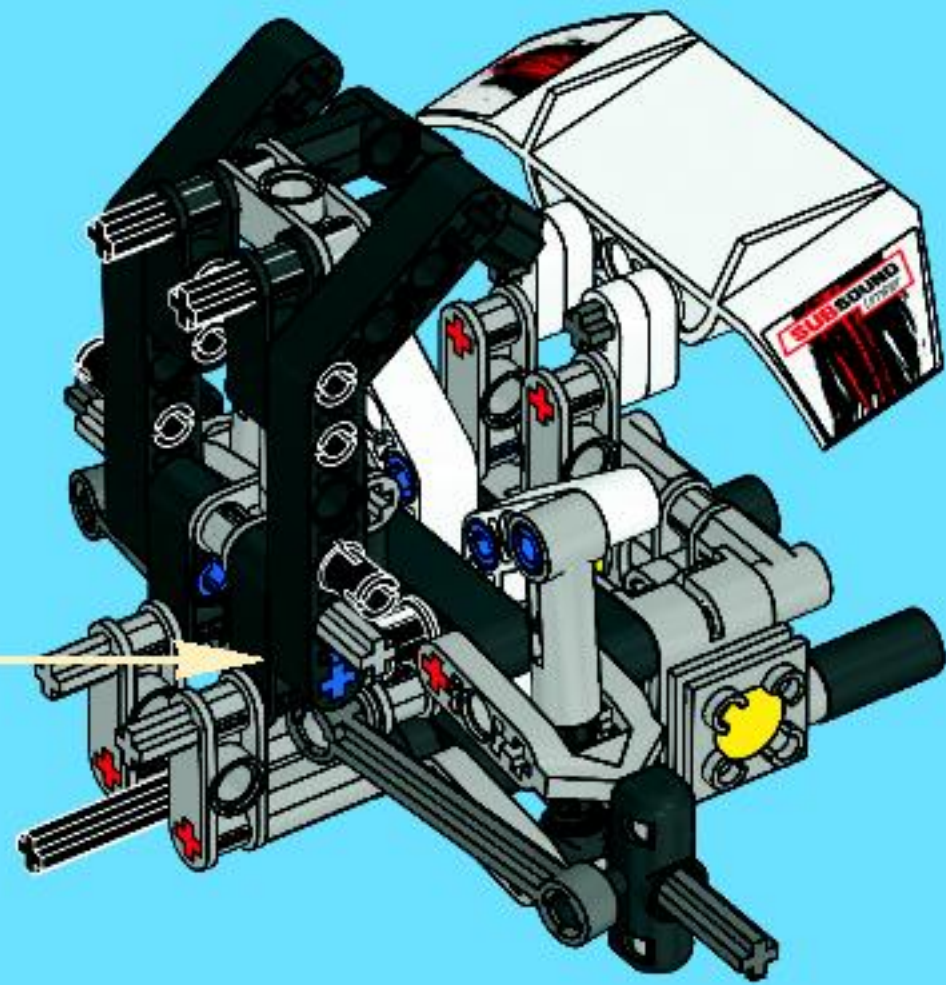
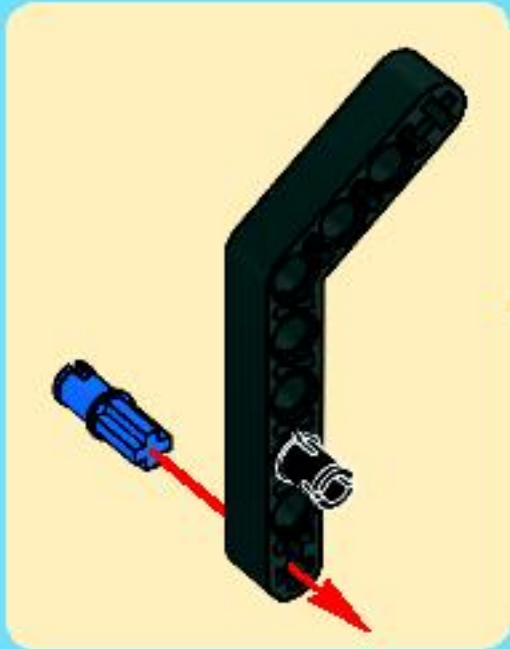

24

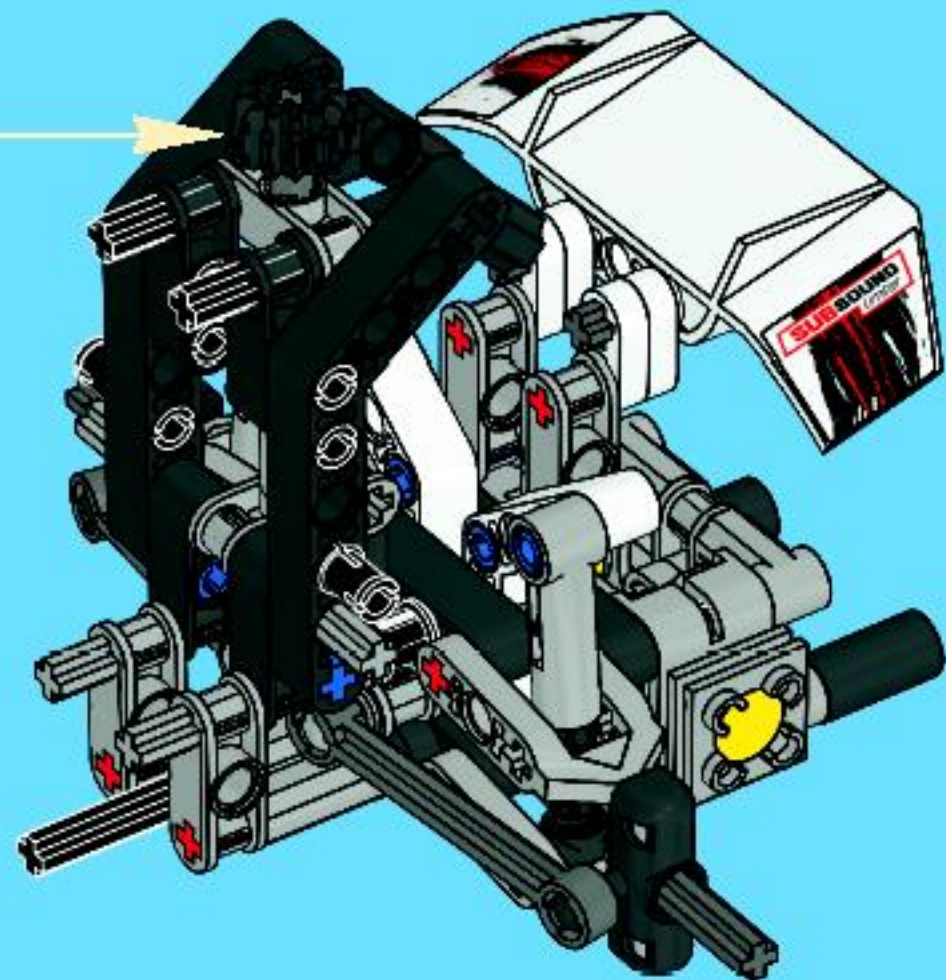
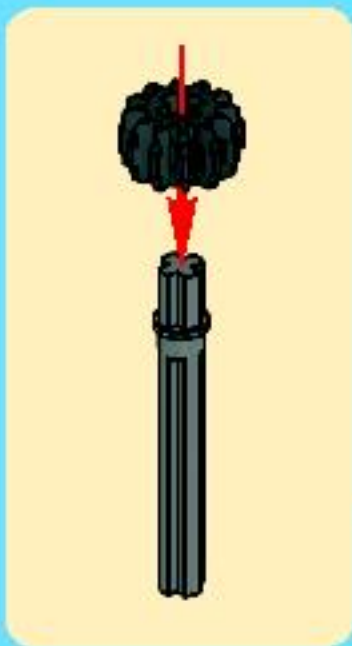



25

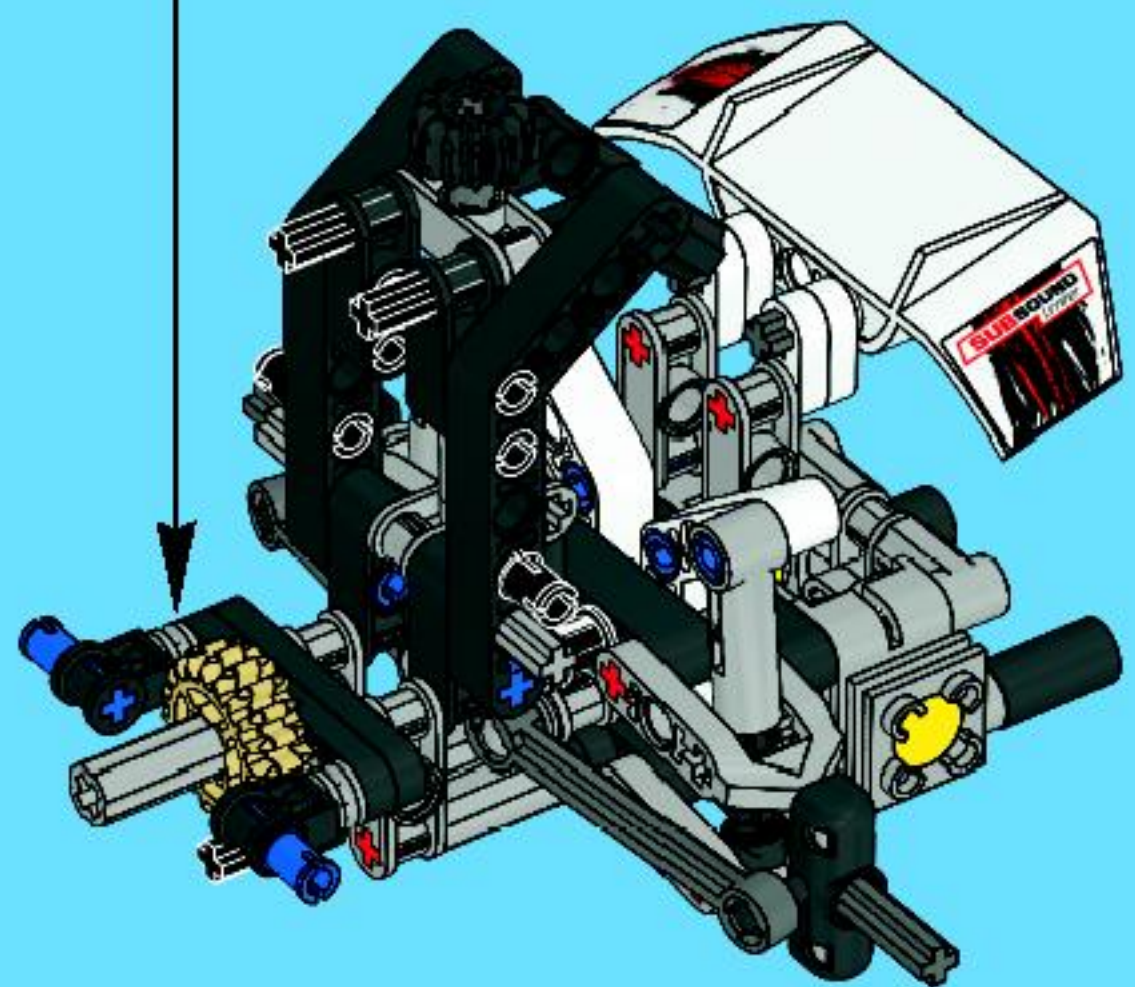
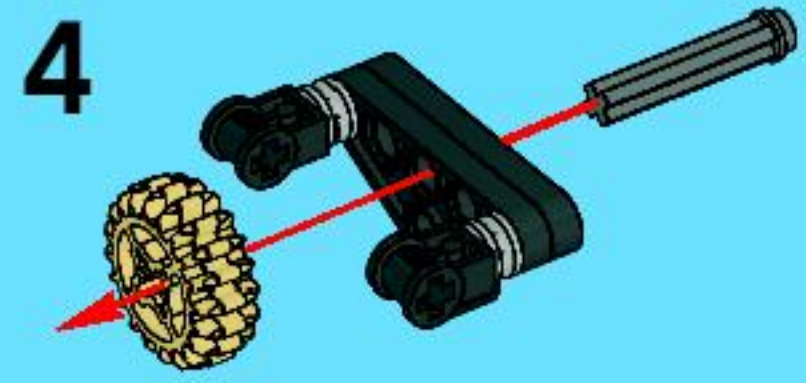
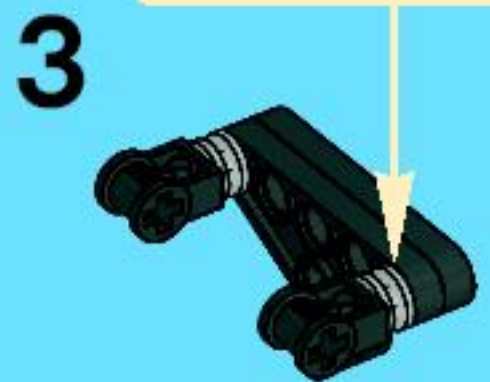
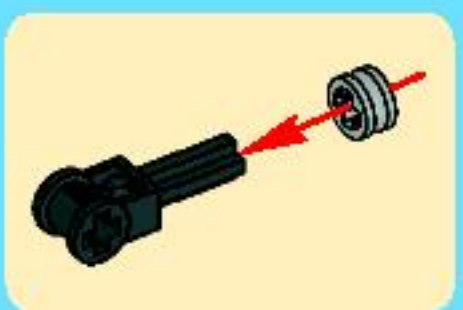
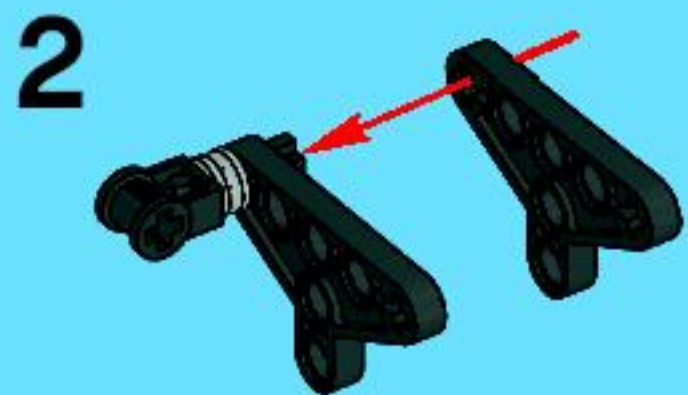
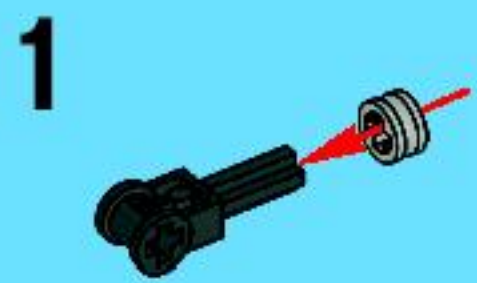



1x

26

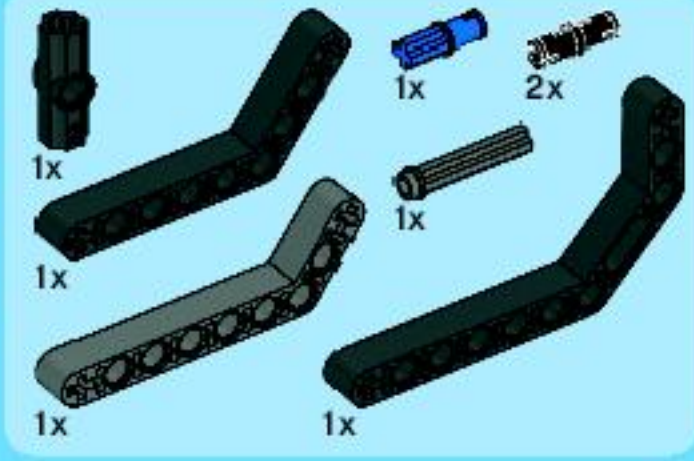
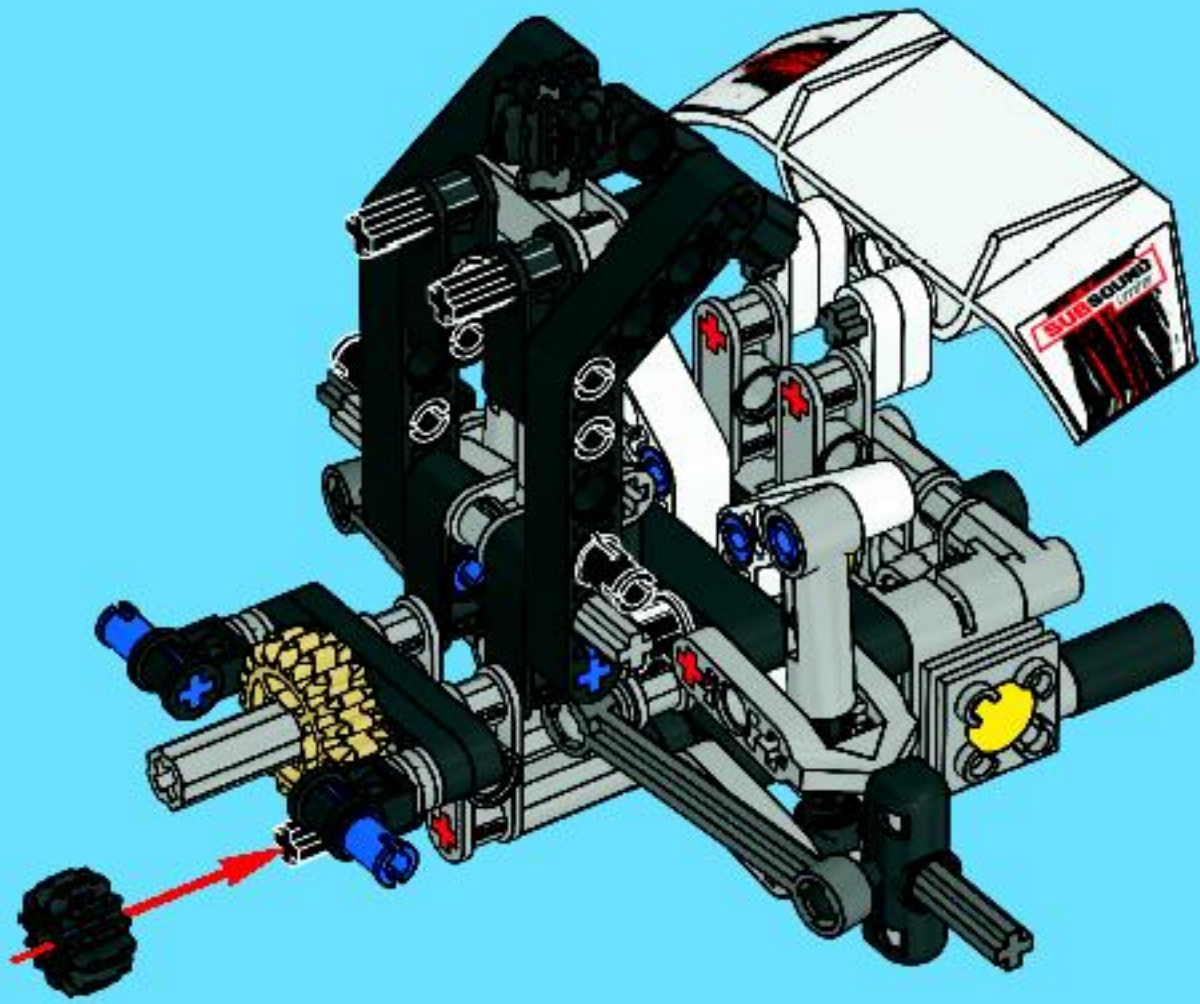

27

1

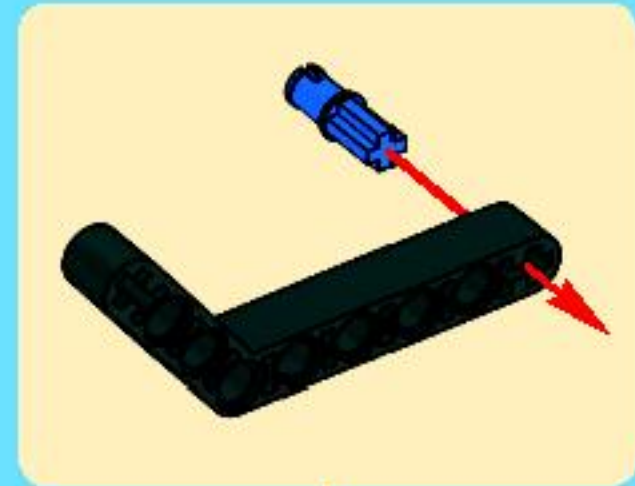
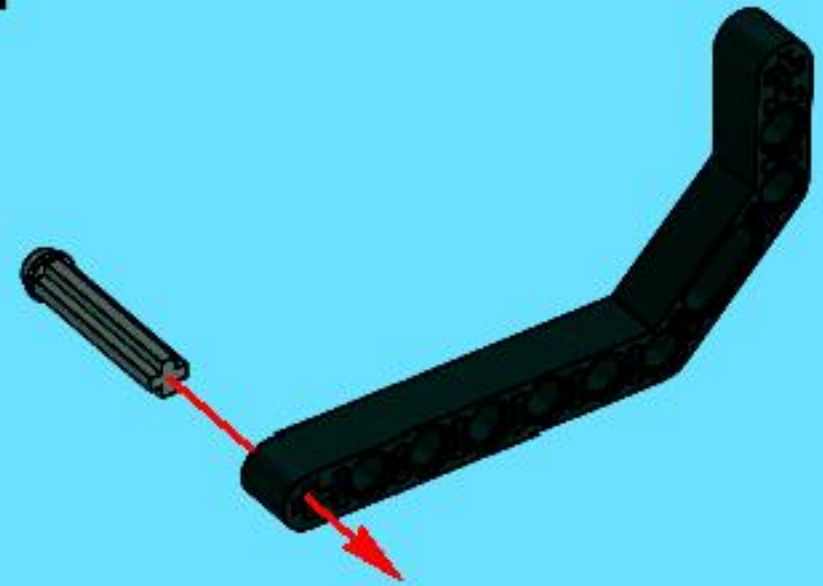

2

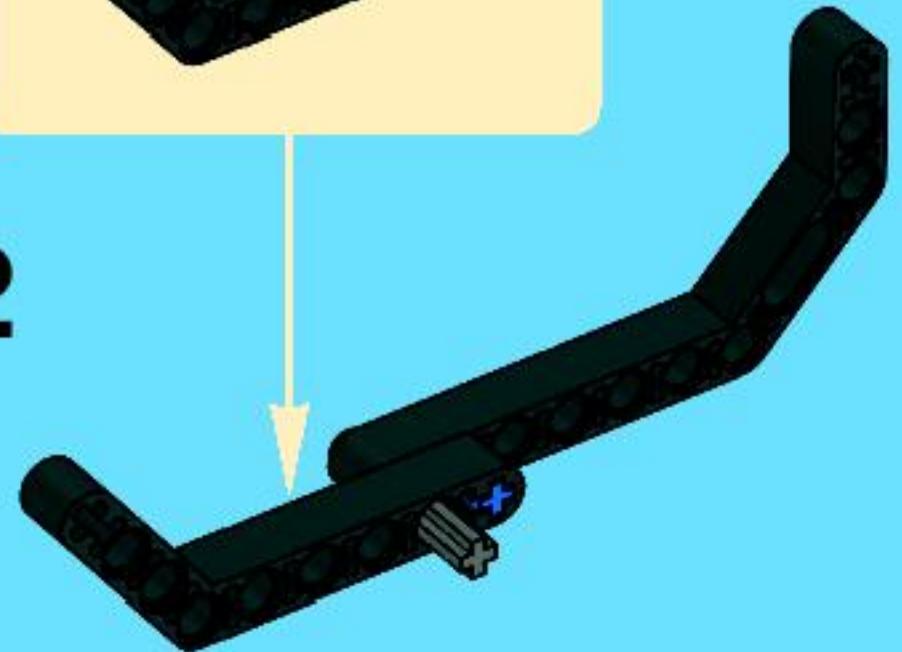

3

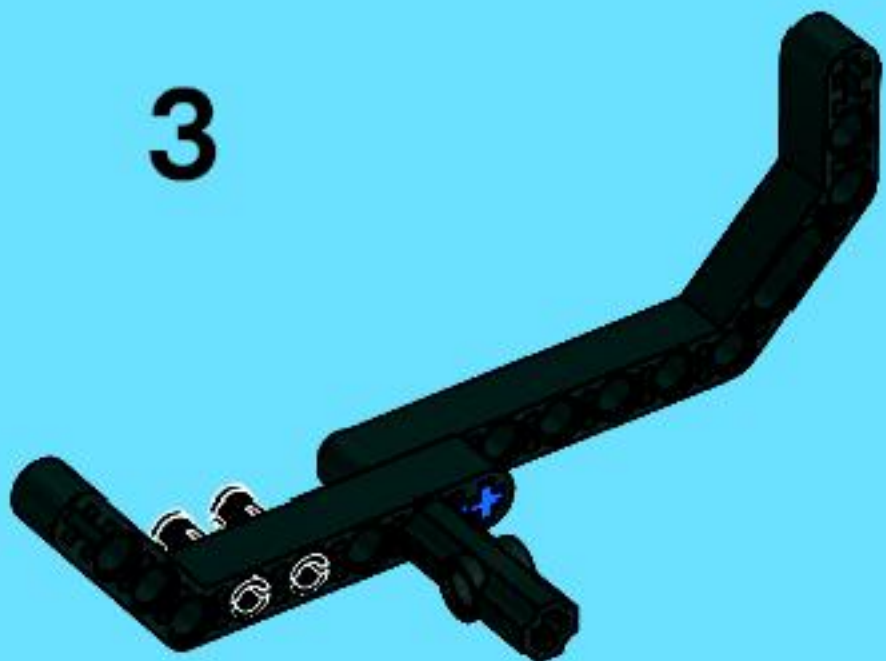

4

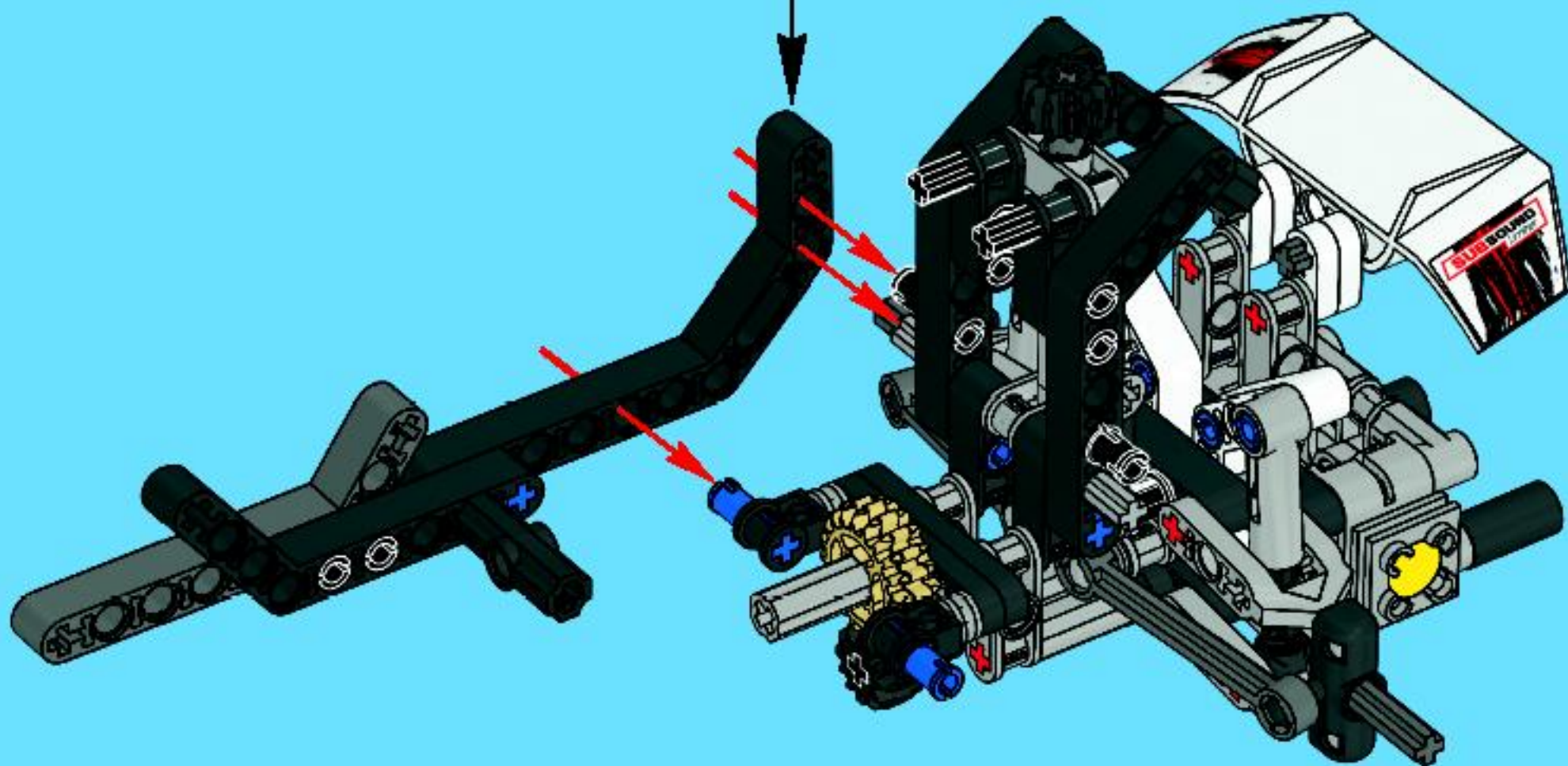
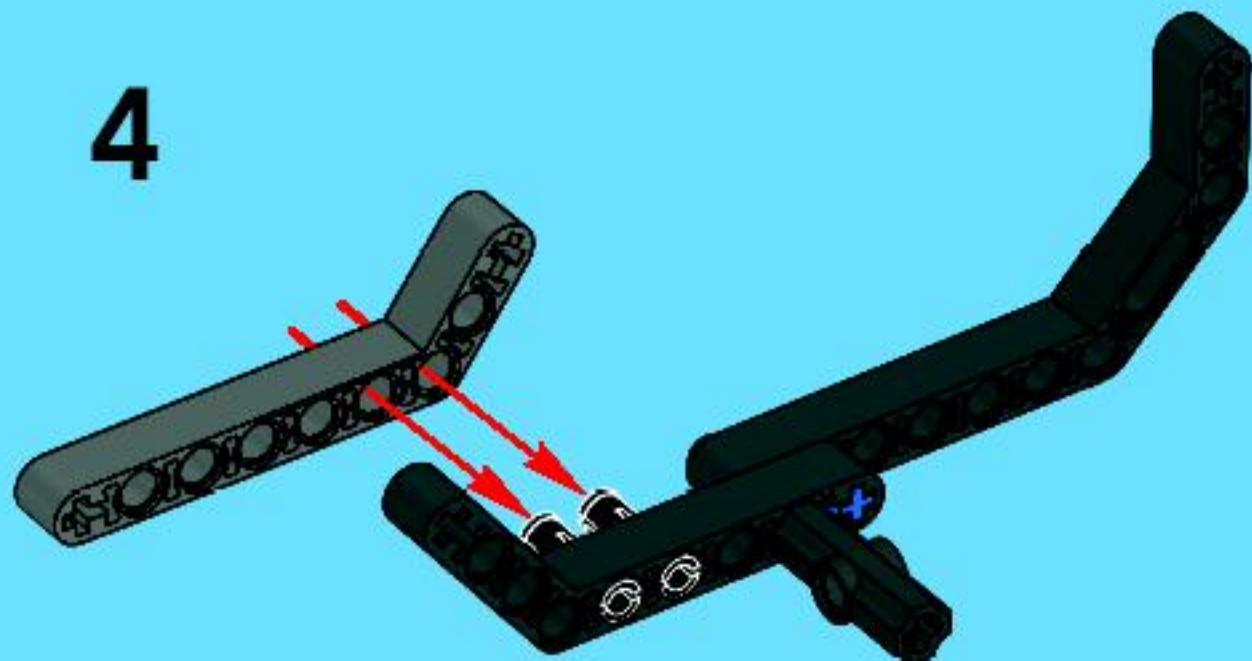

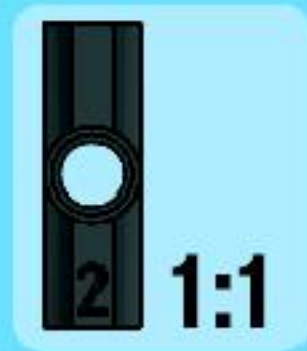
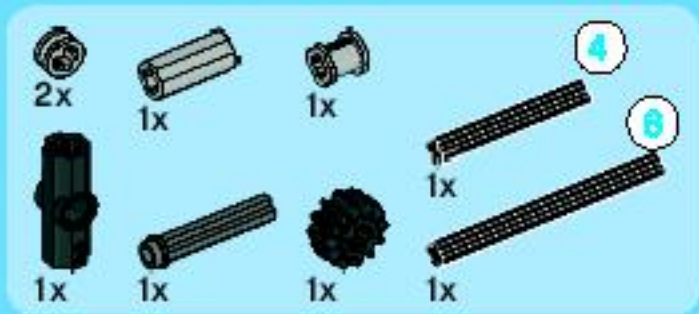

28

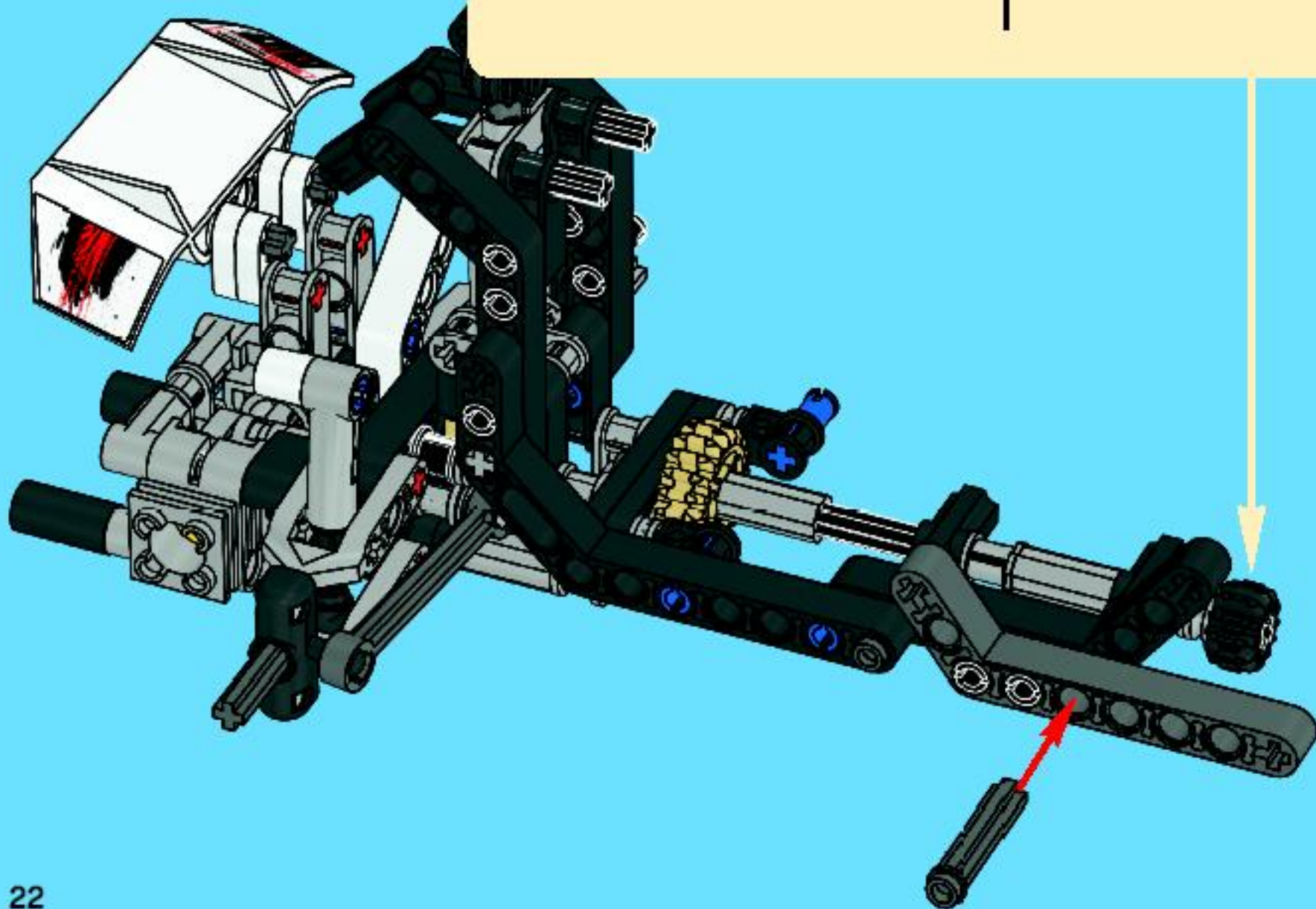
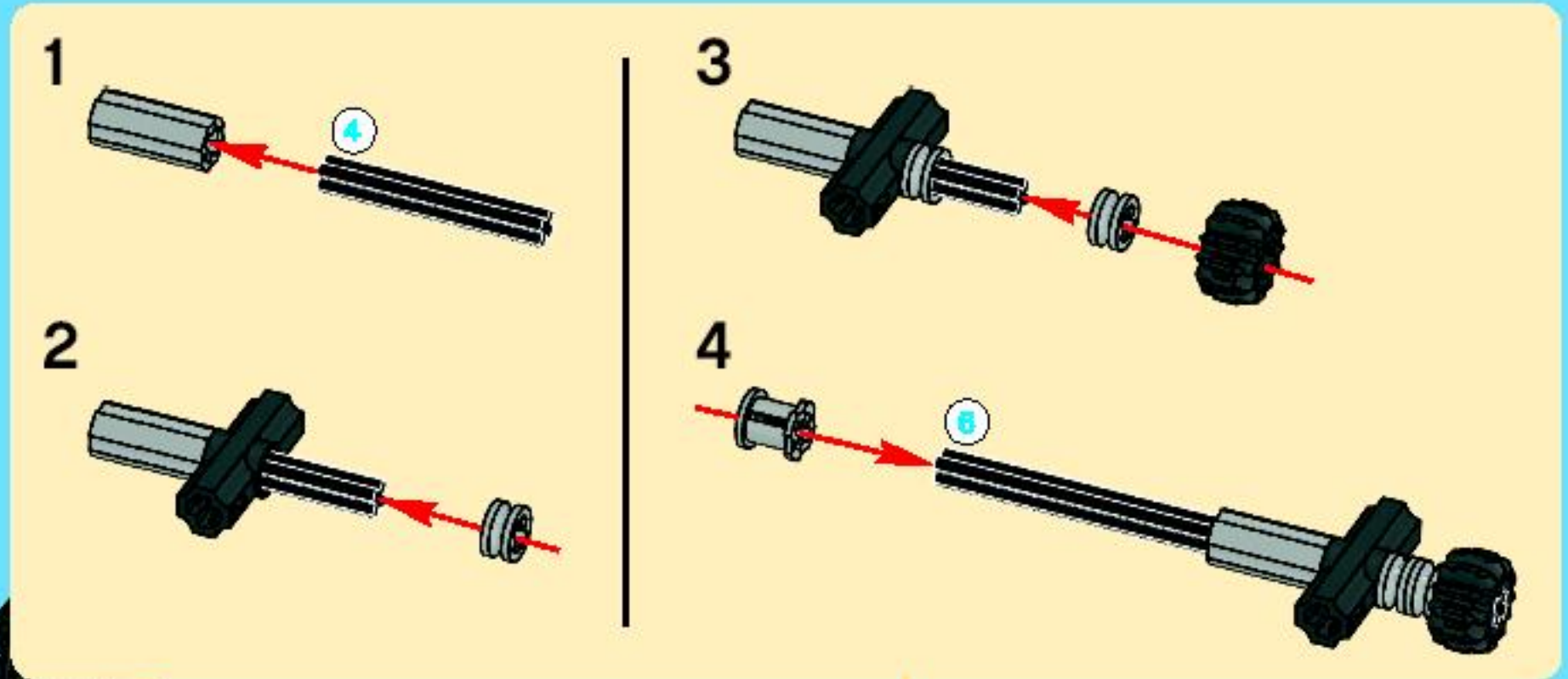



29

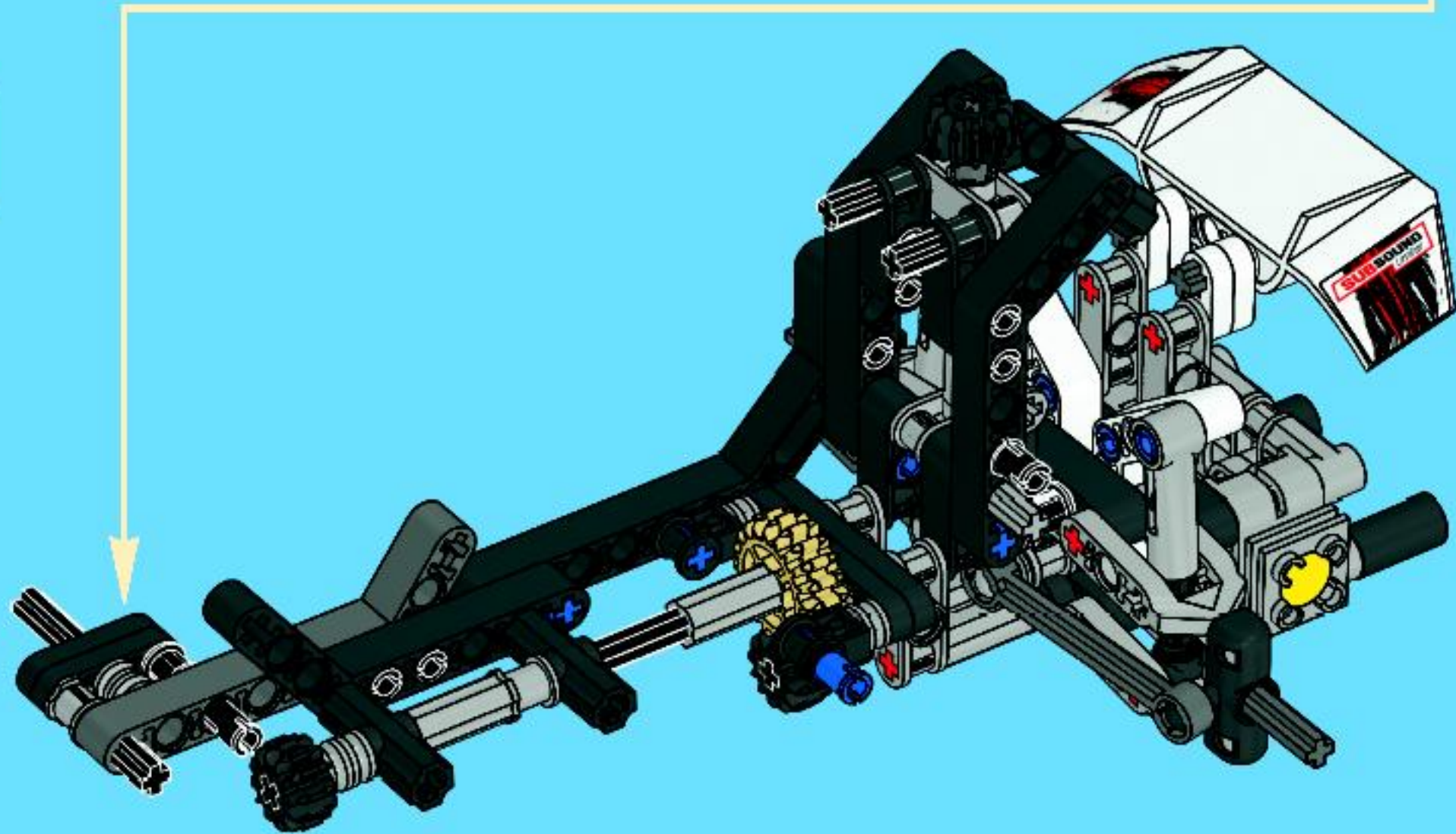
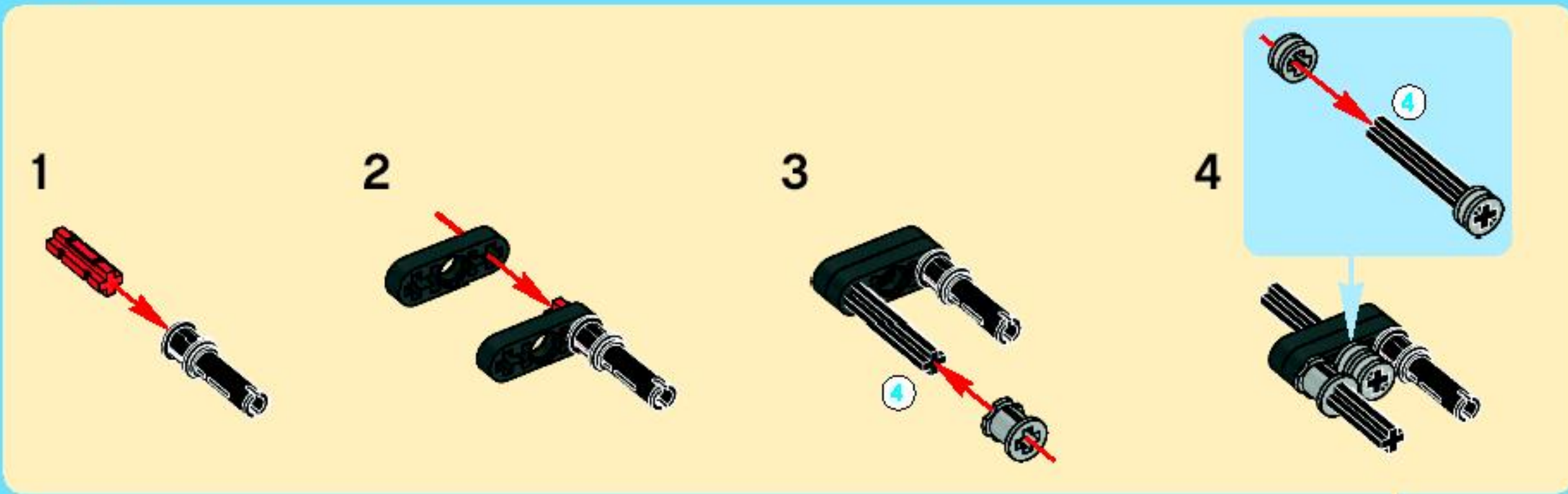

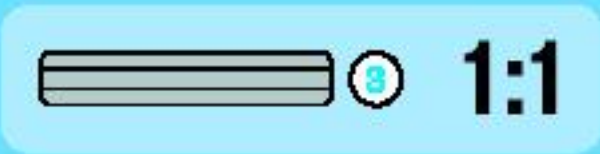

30

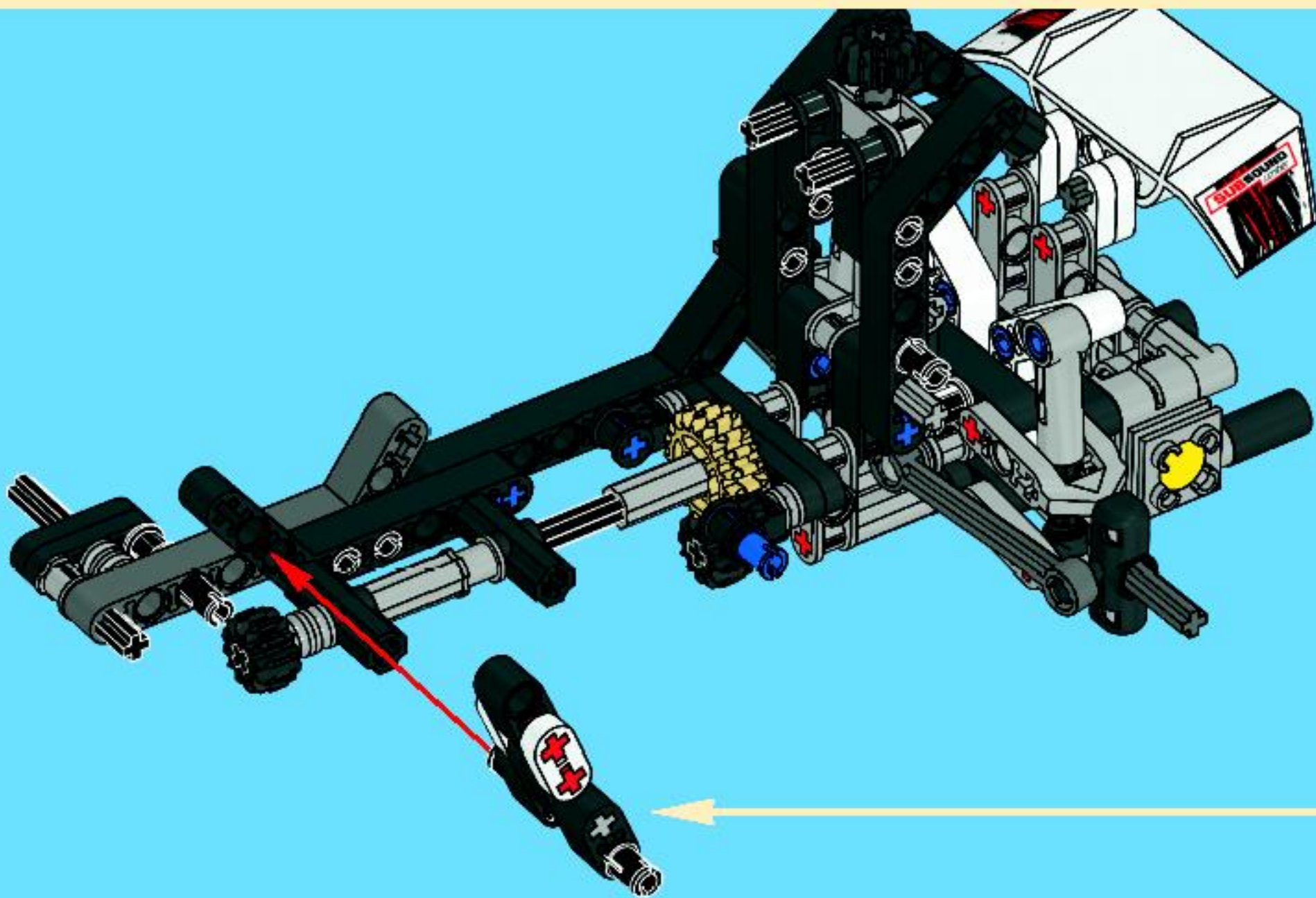
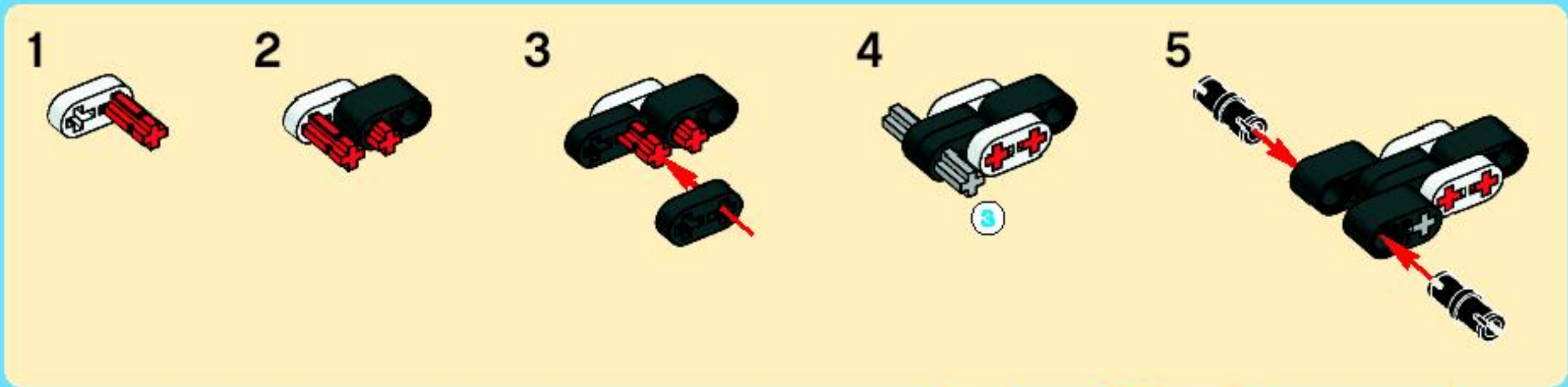

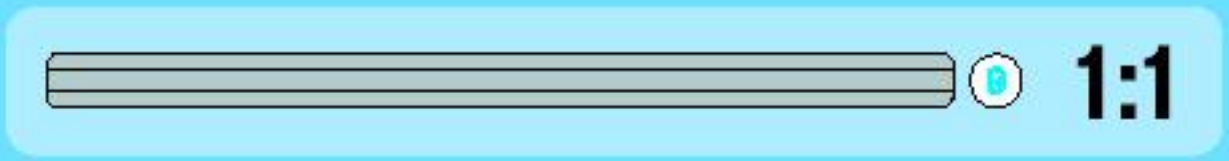
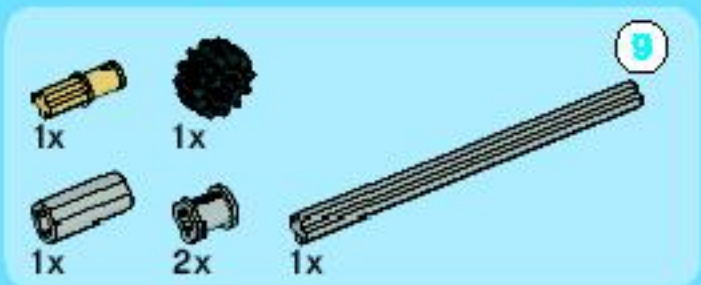

31

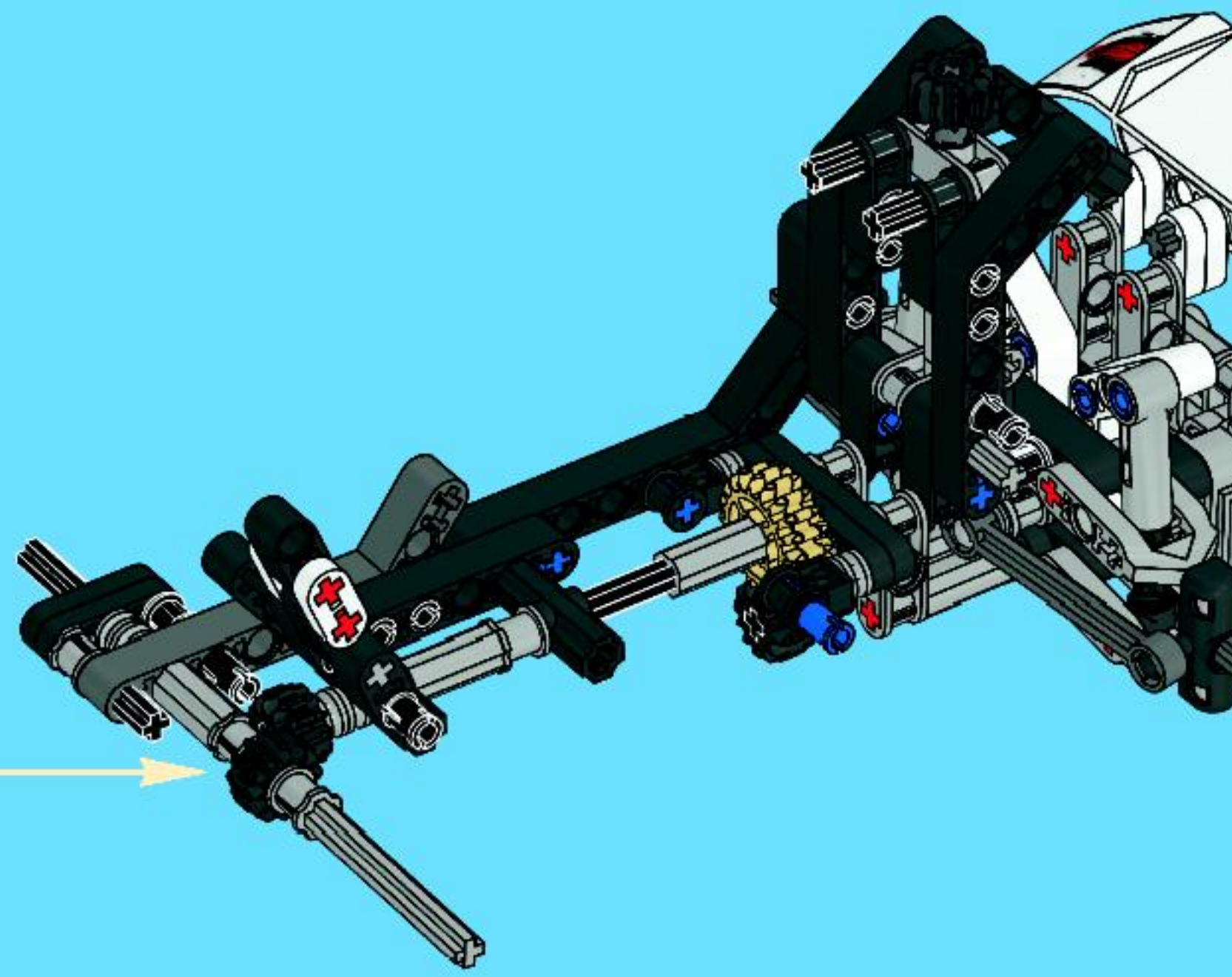
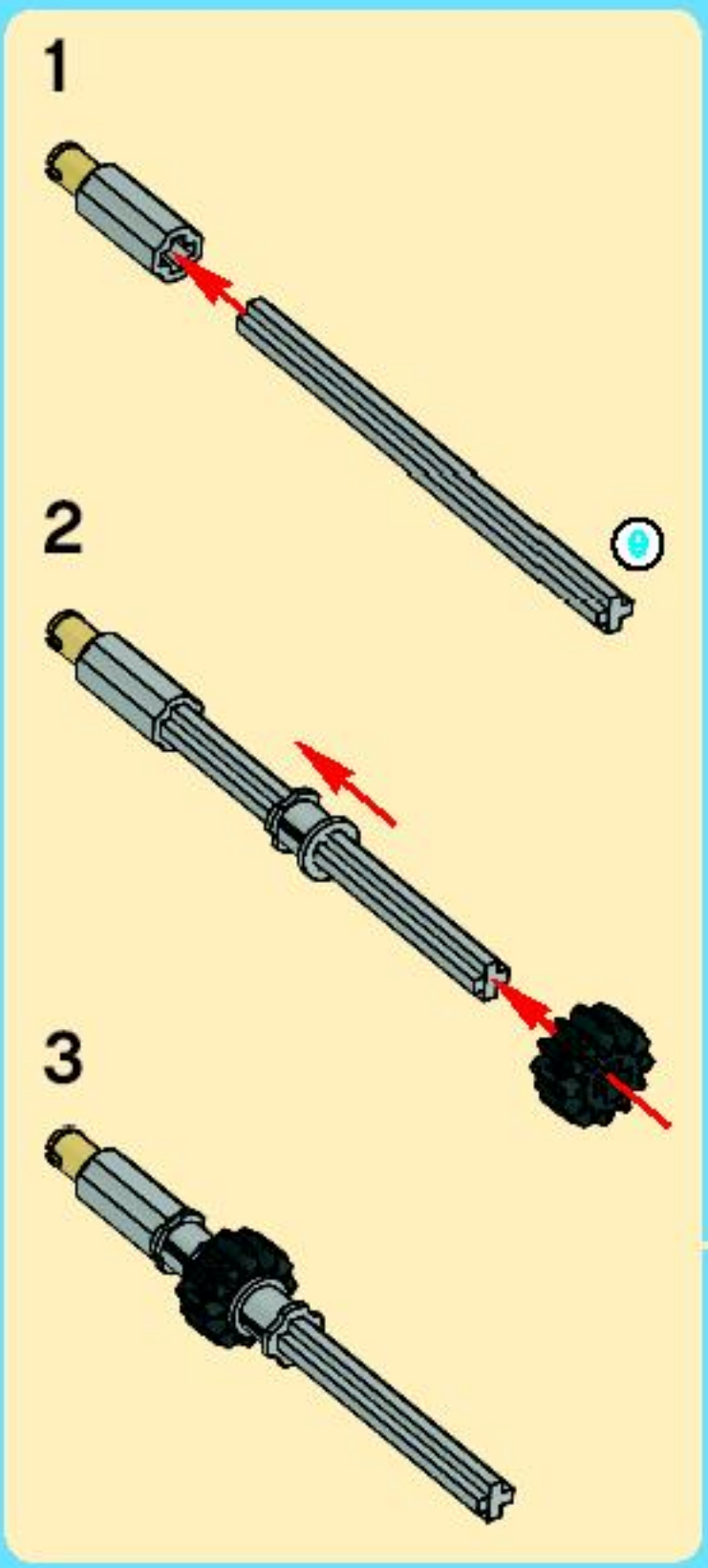

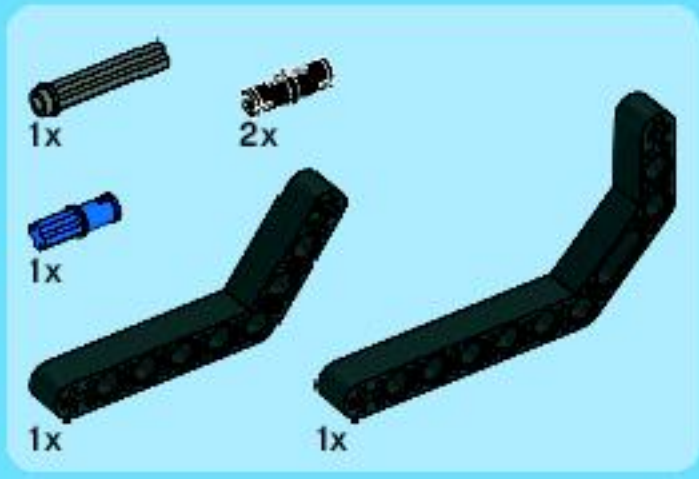

32

1

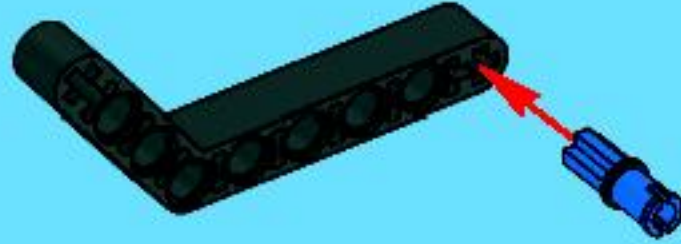

2

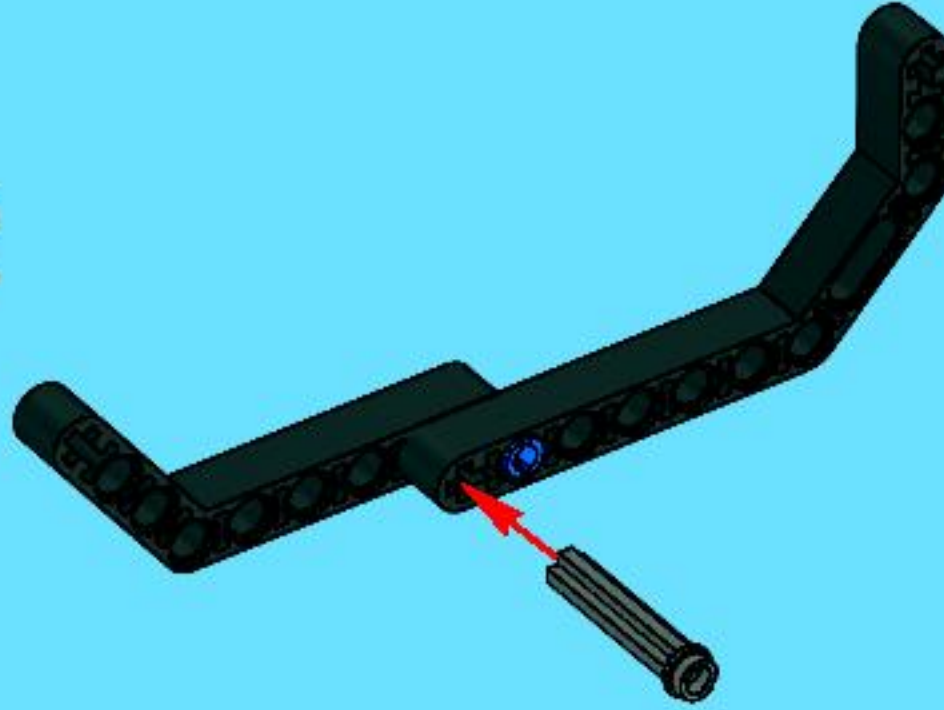

3

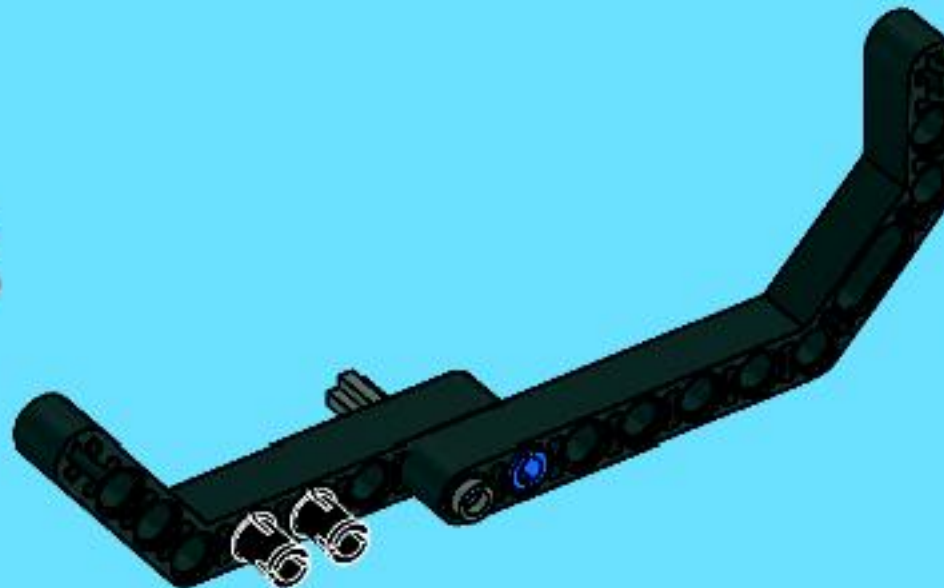

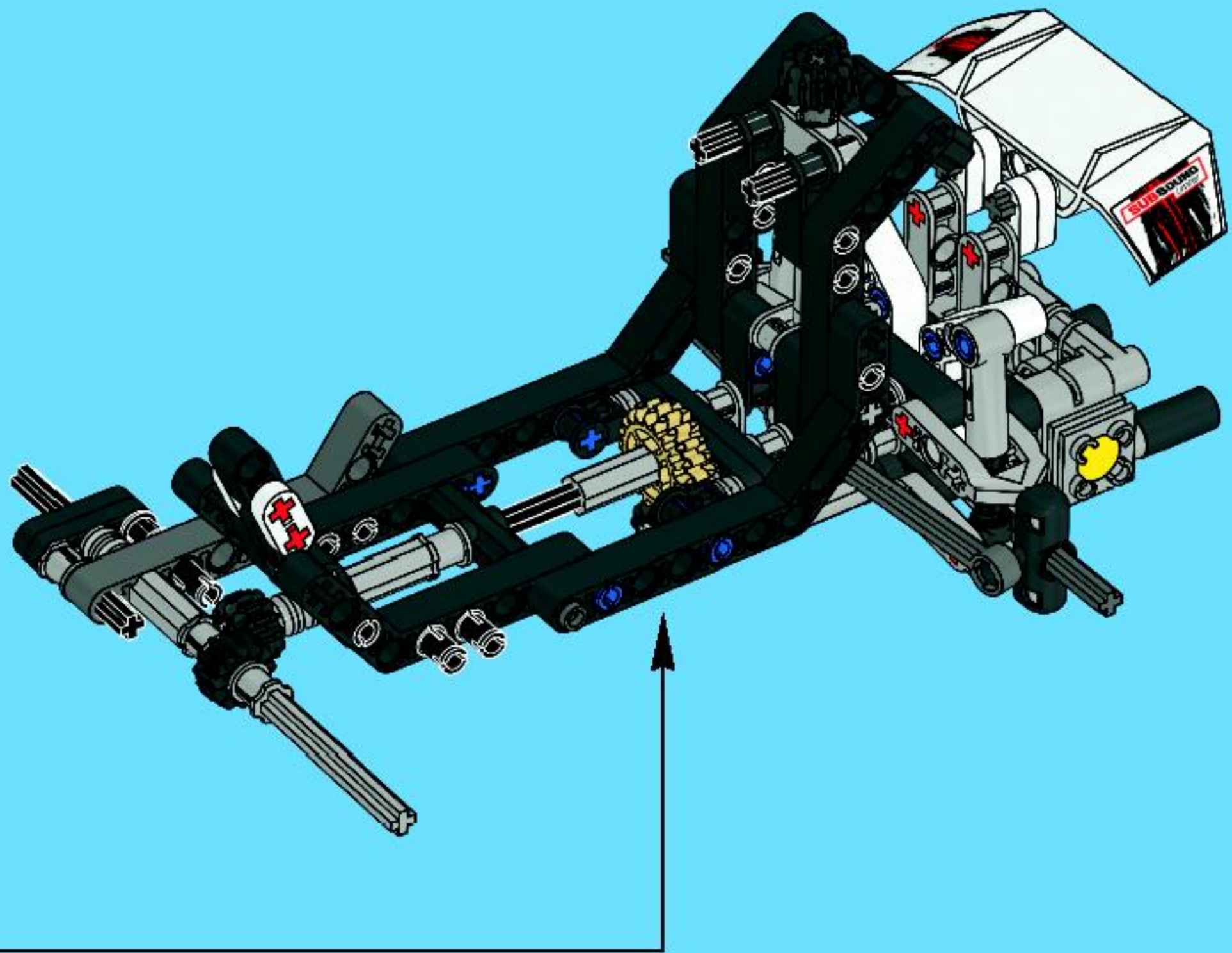

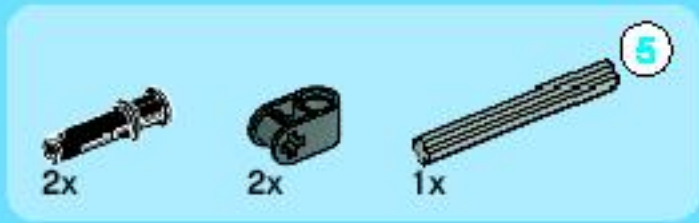

33

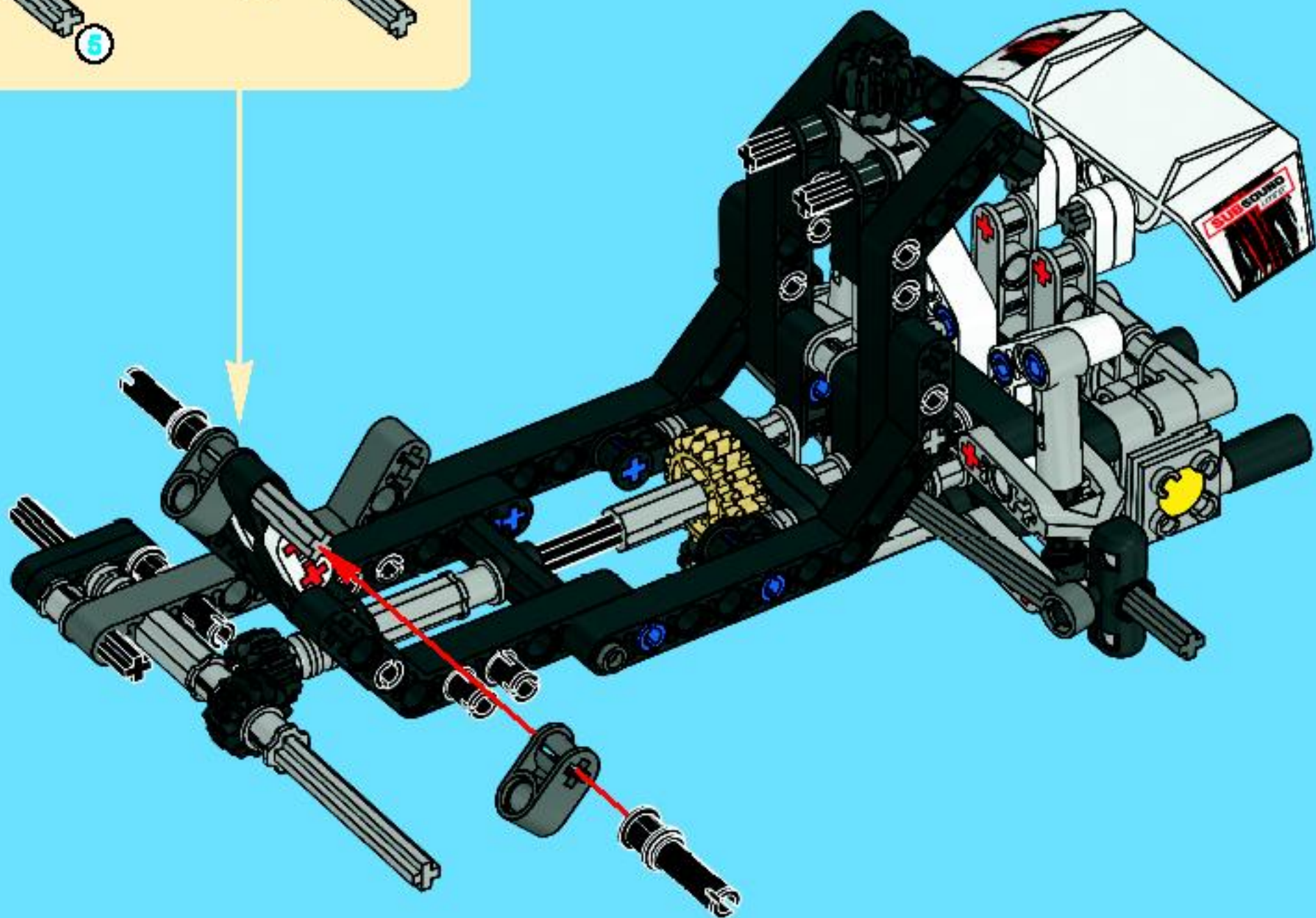
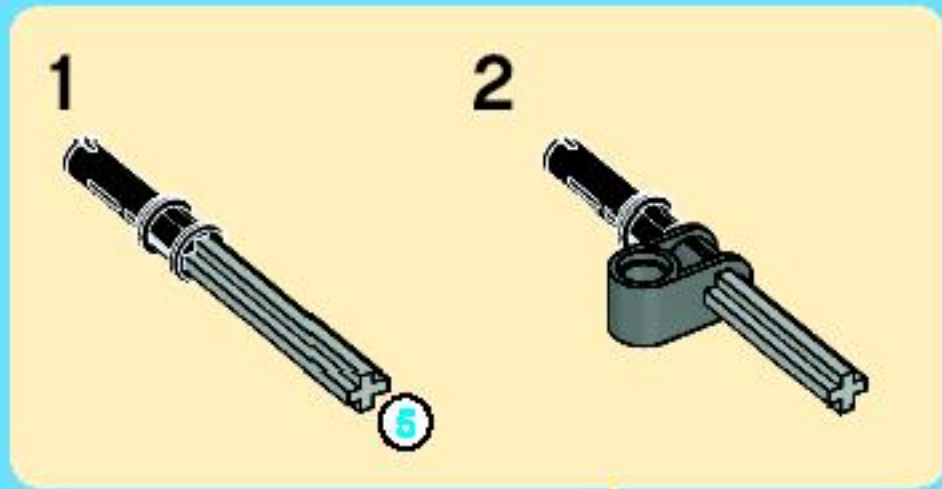

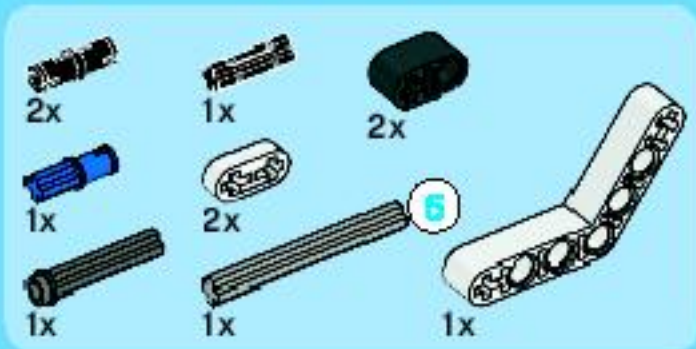

34

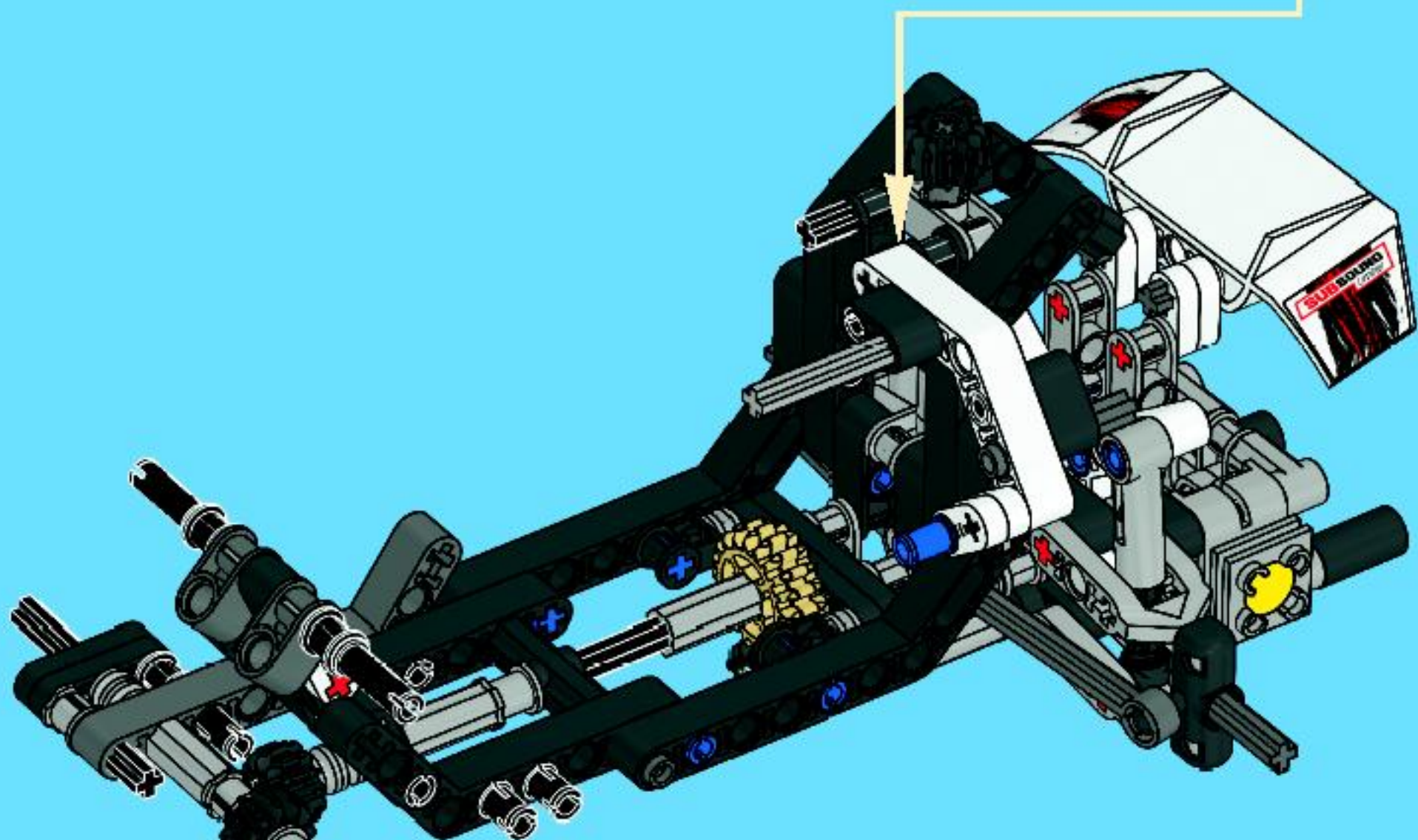
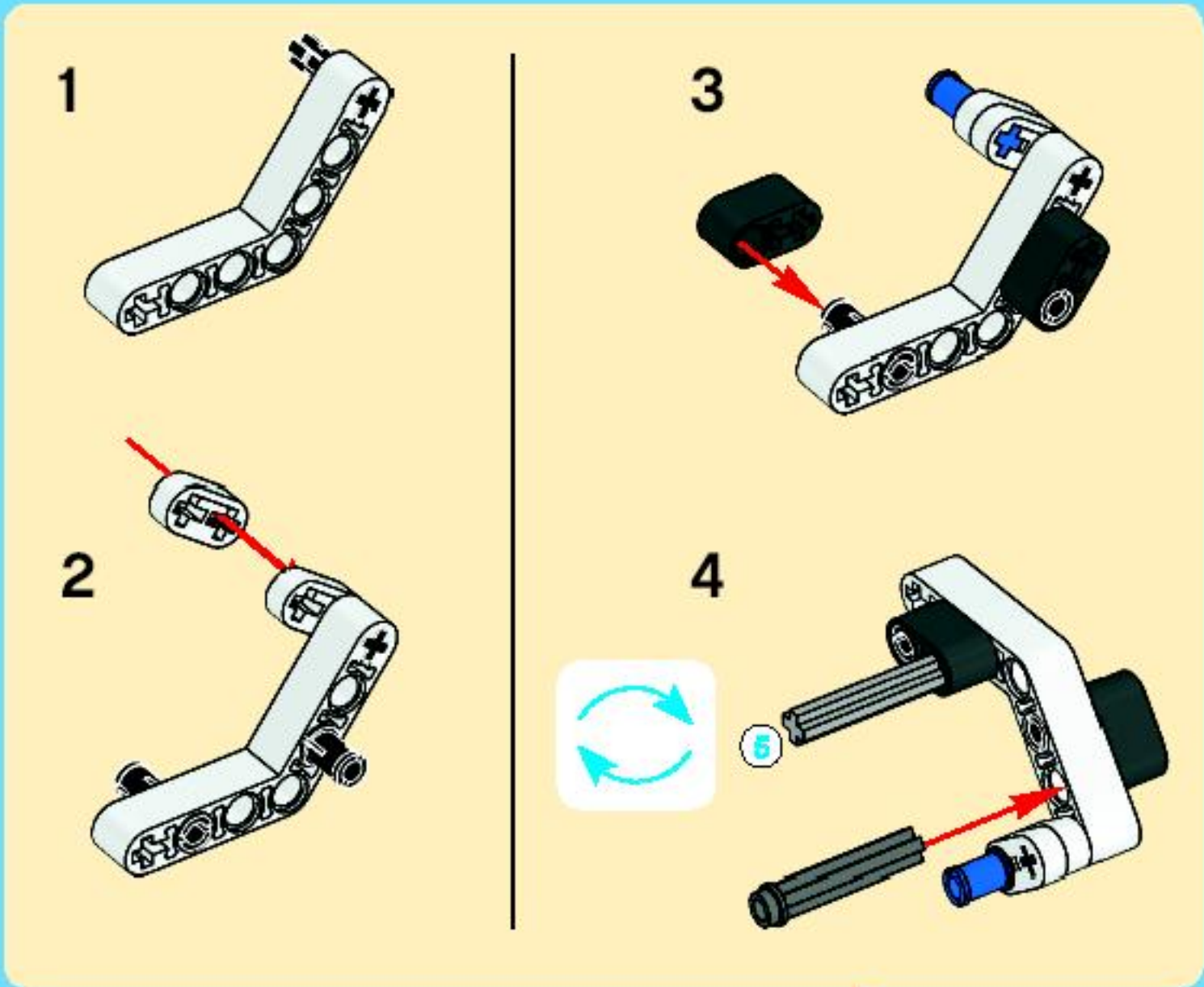
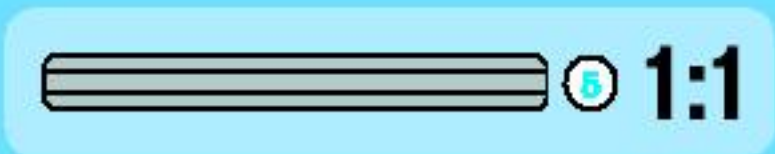

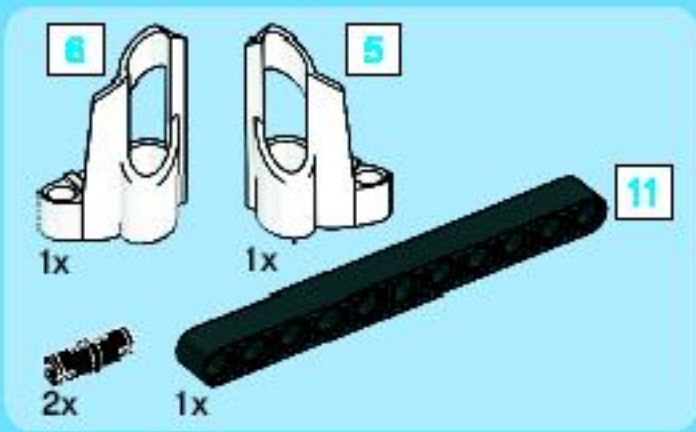

36

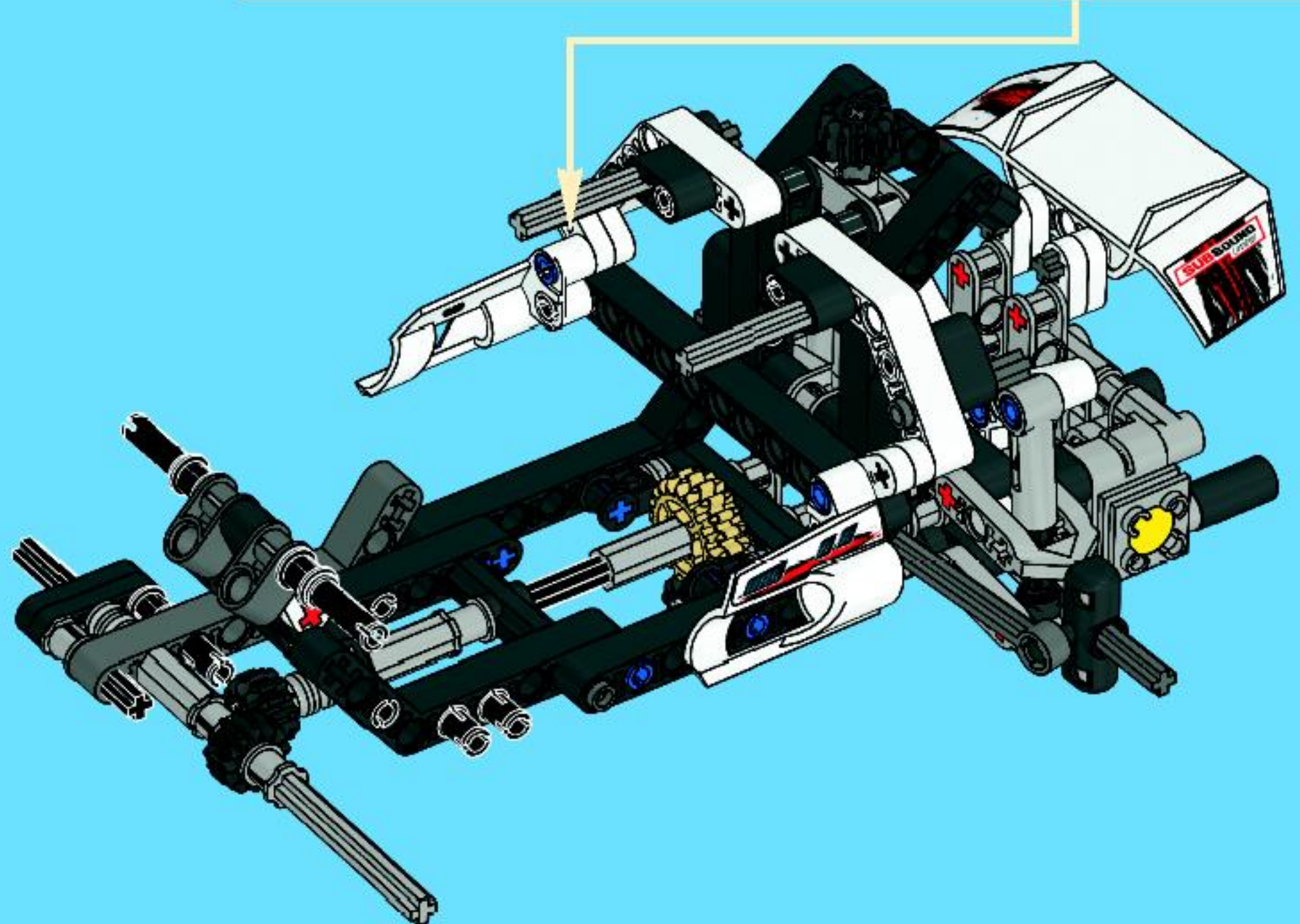
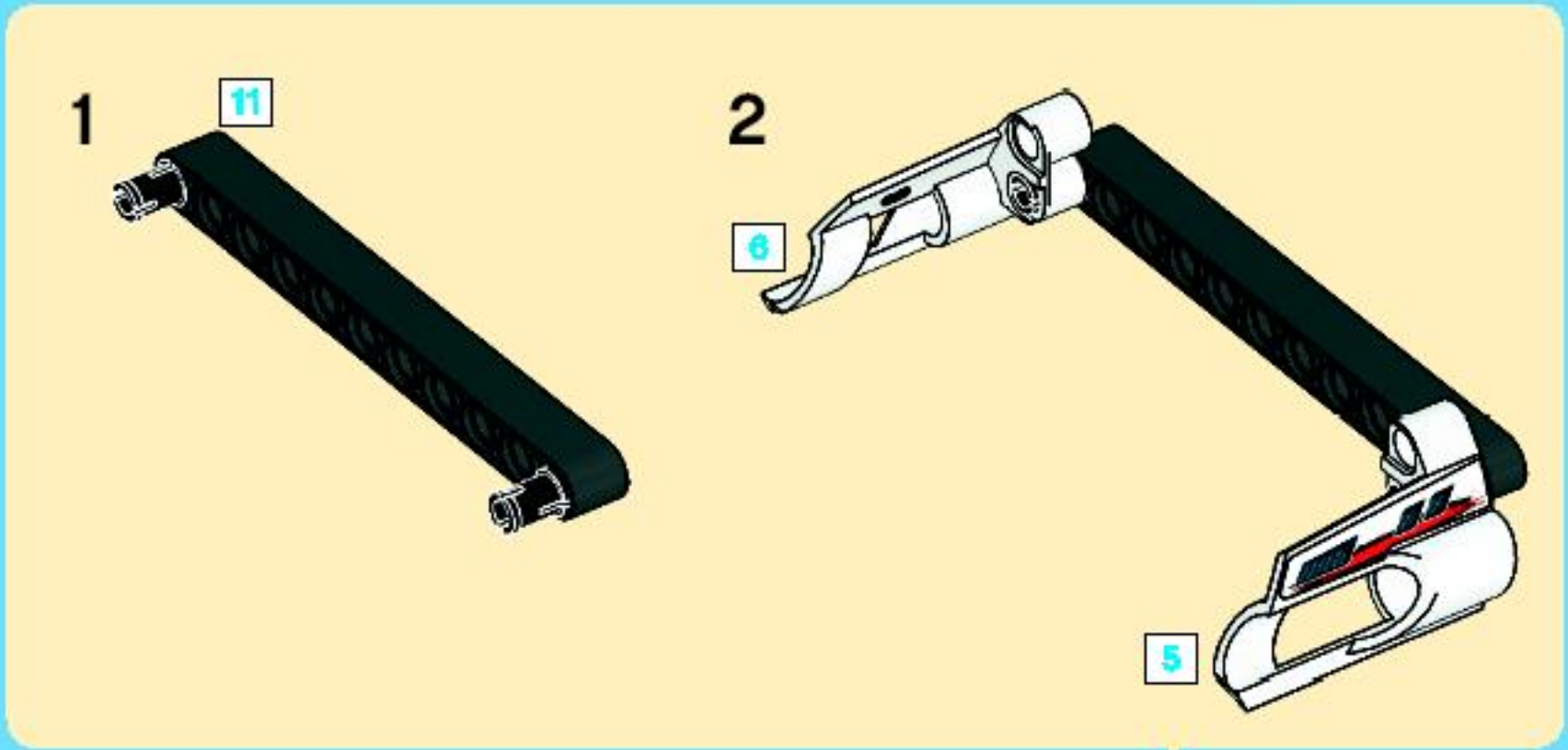

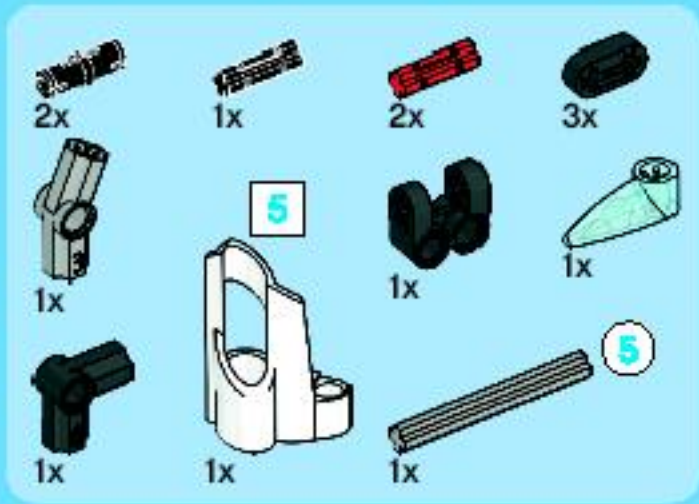

37

1

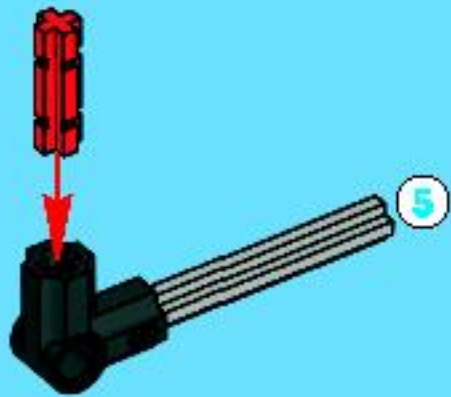

2

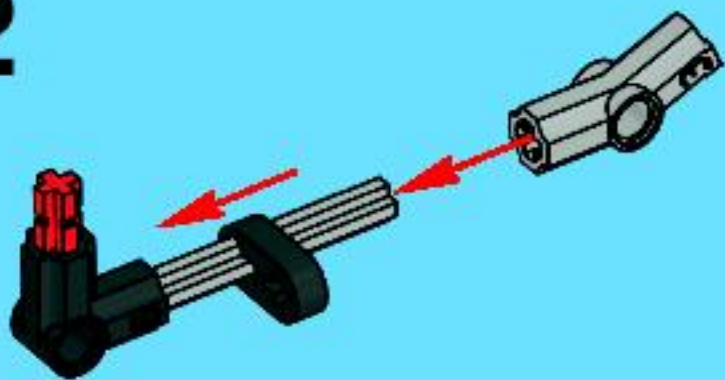

3

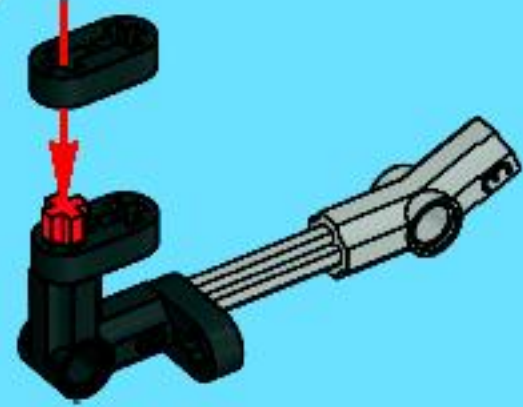

4

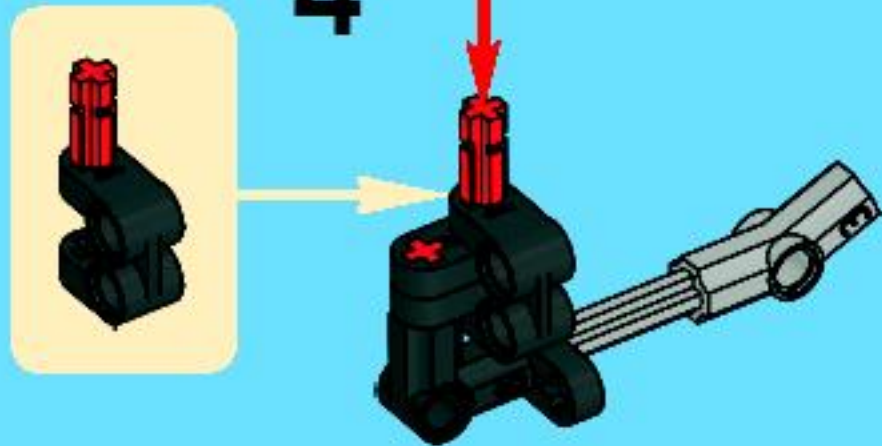

5

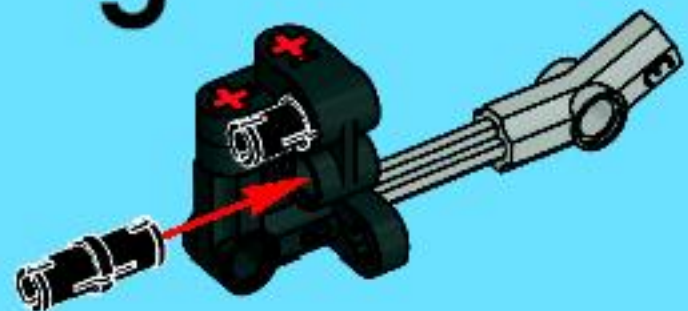

6



7

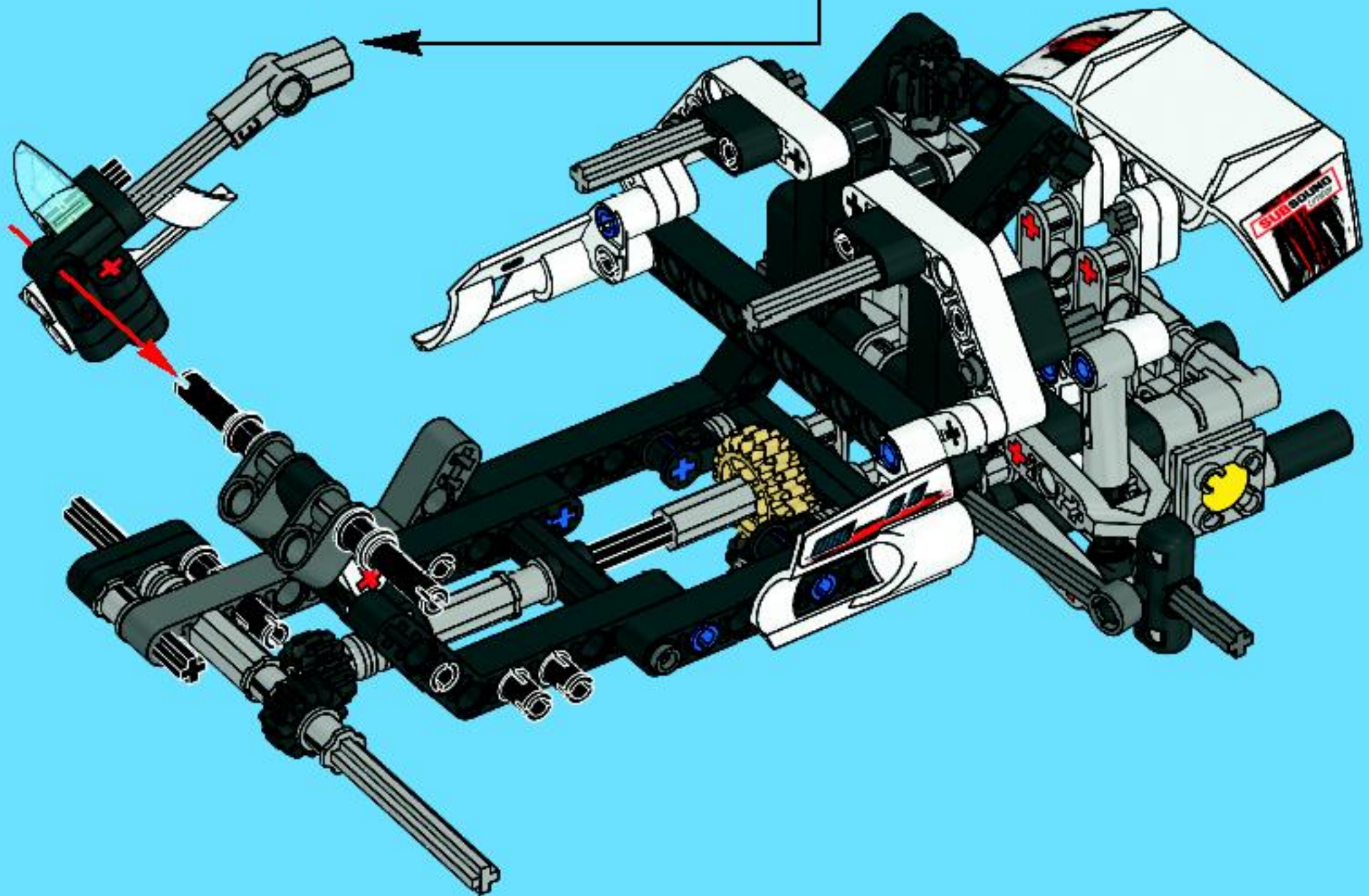
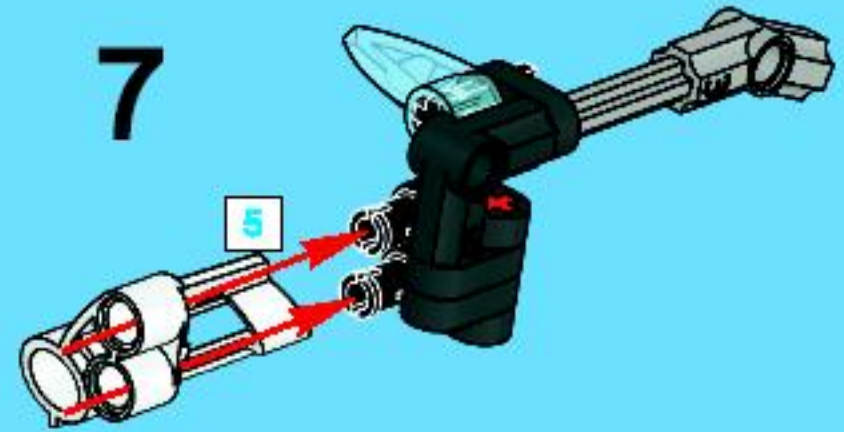

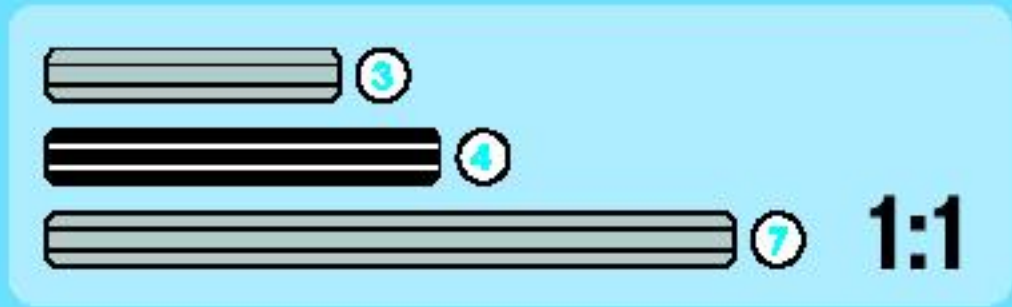
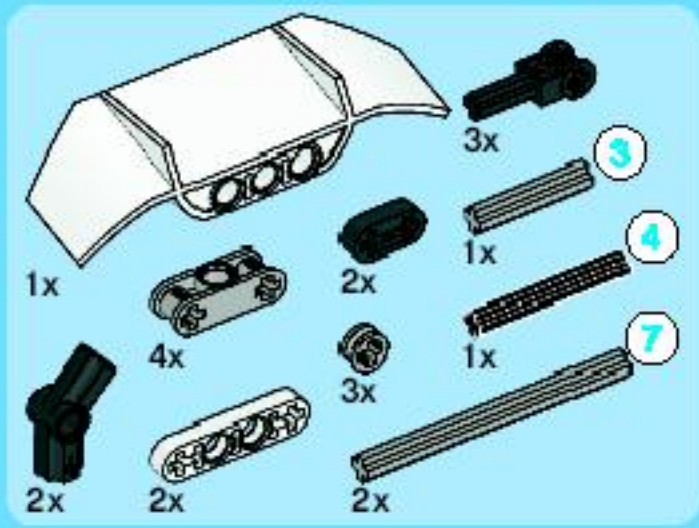

38

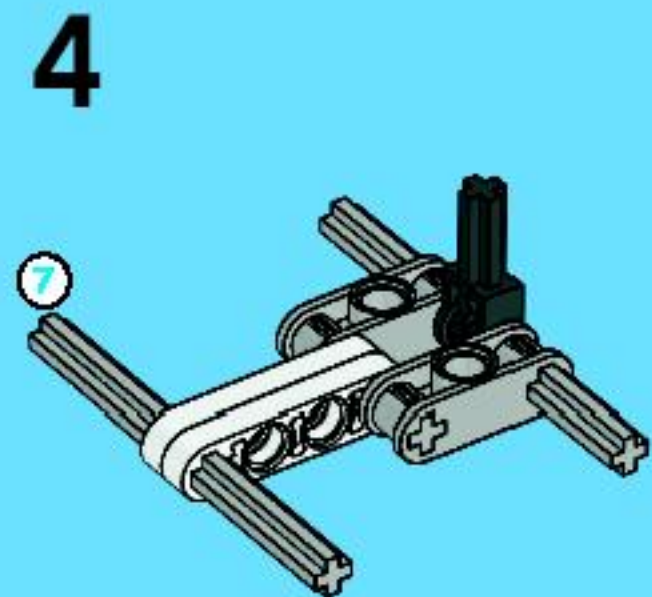
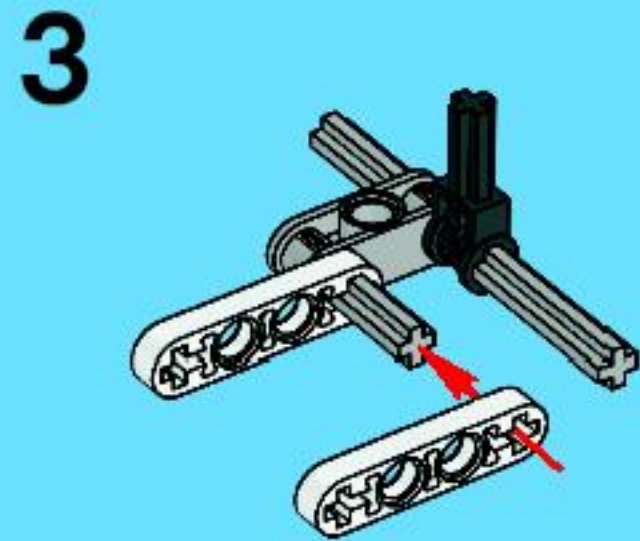
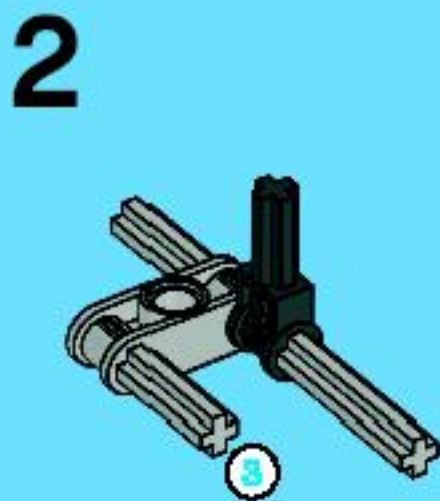
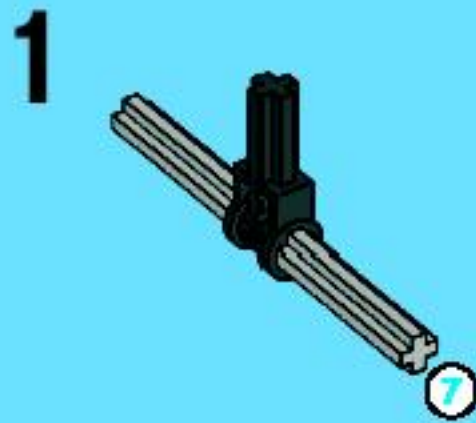

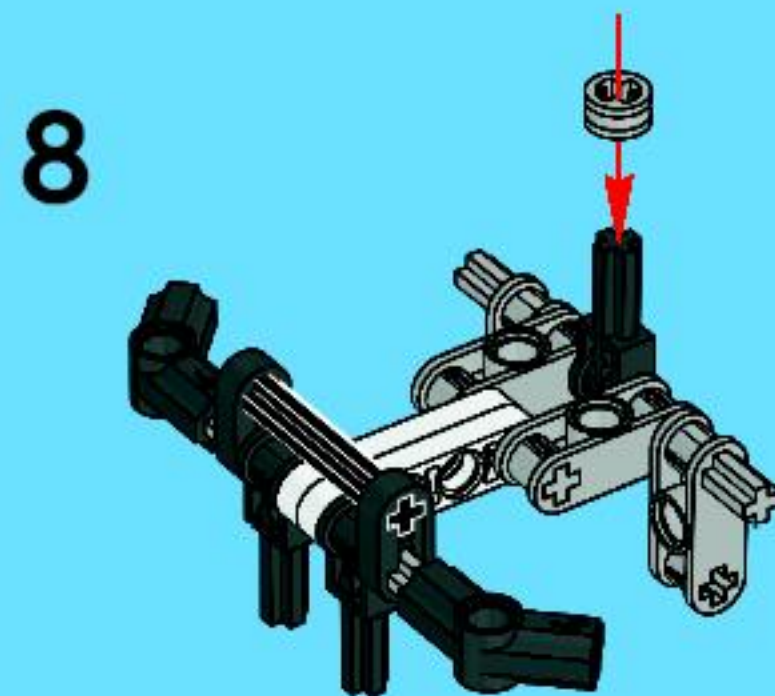
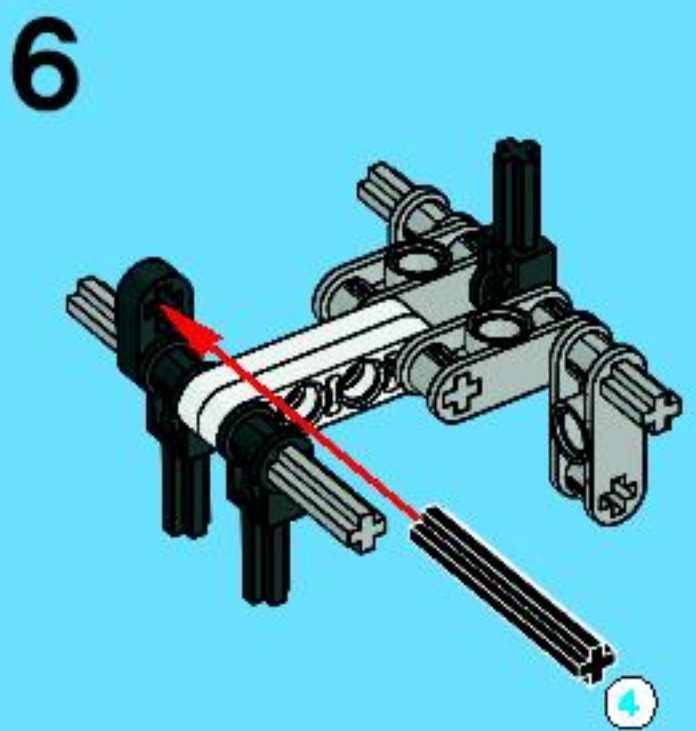
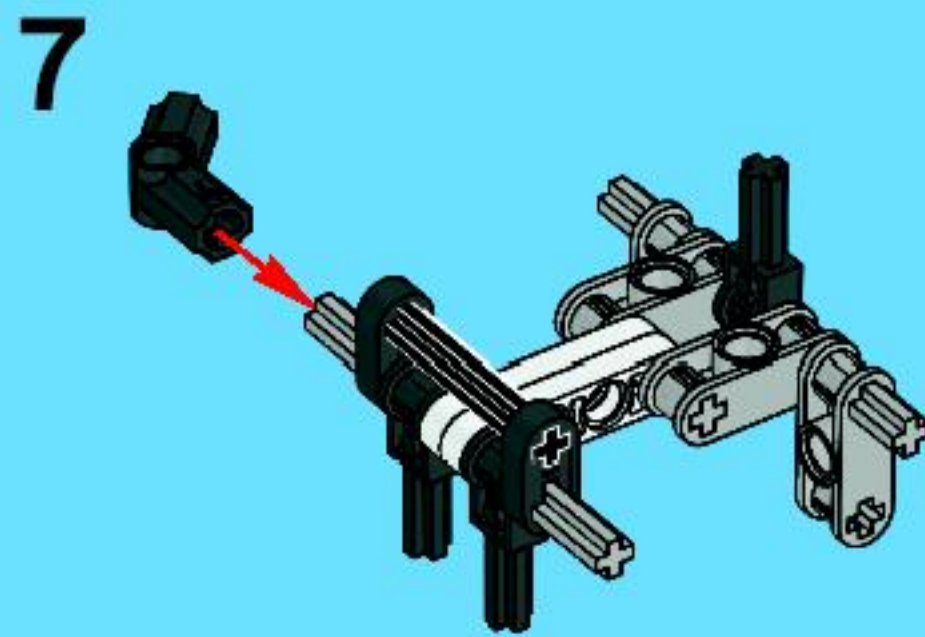
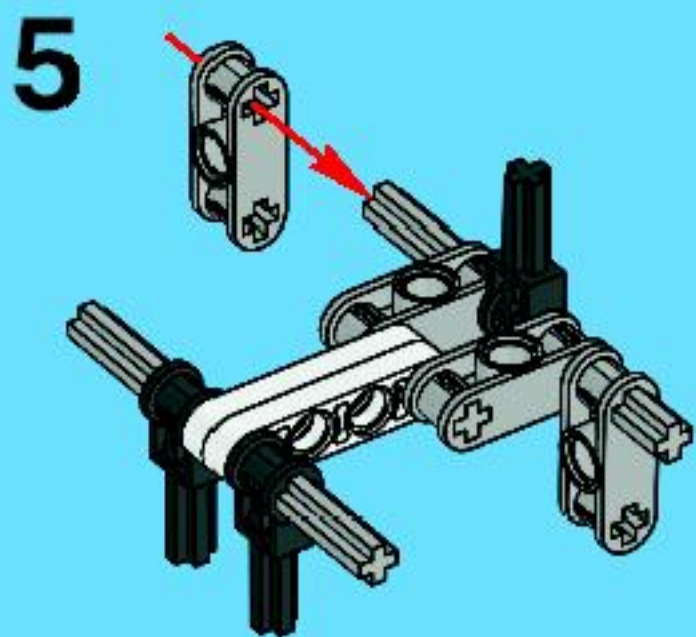

9

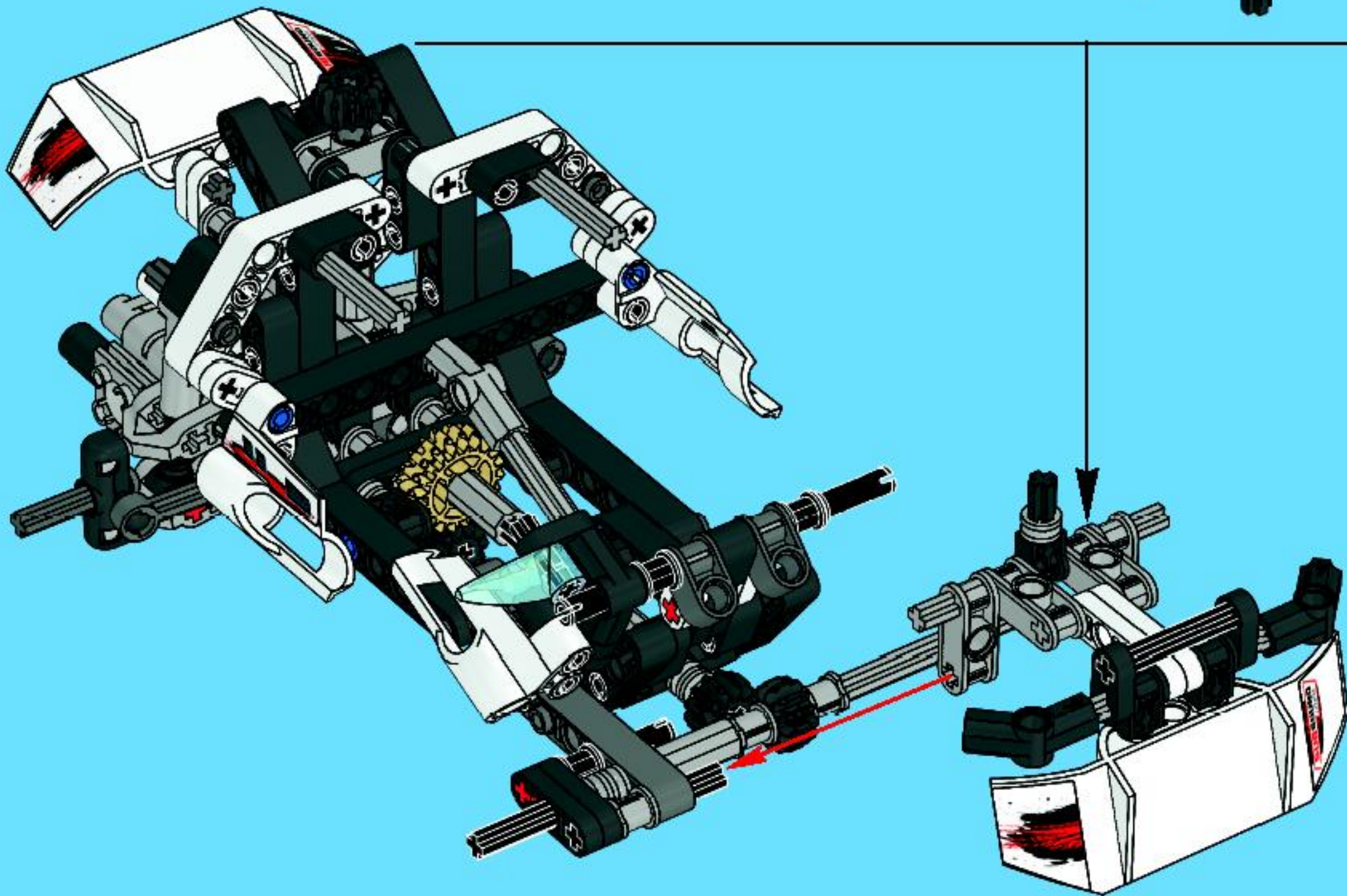
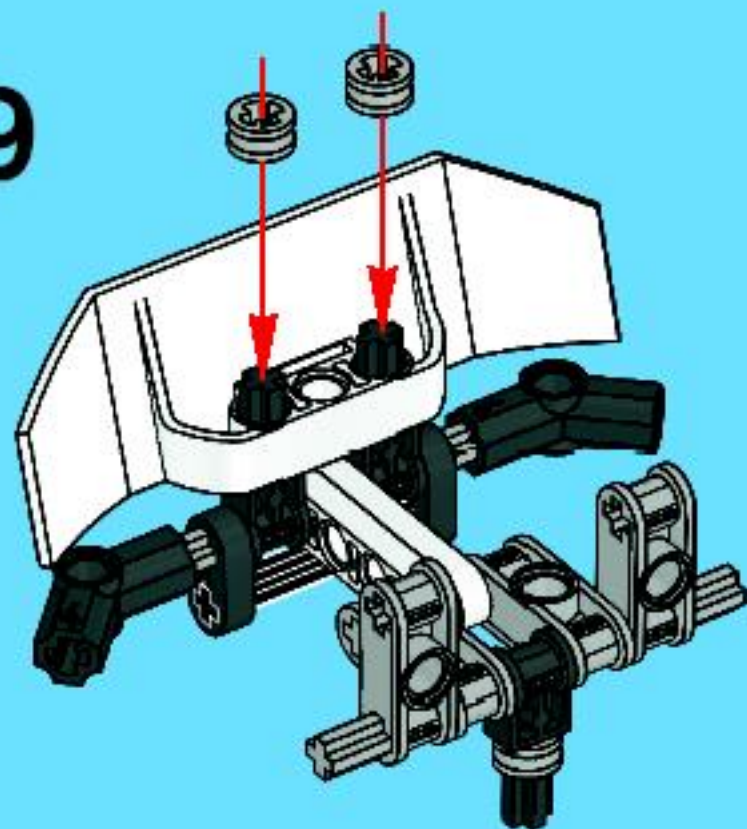

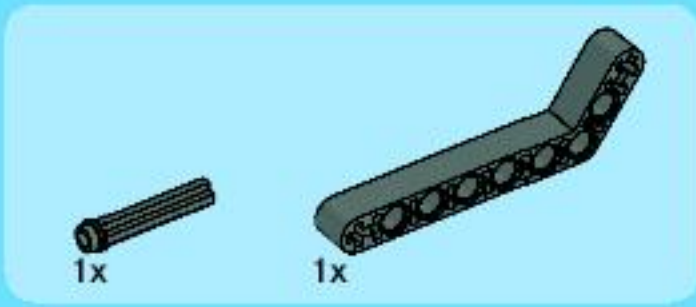

39

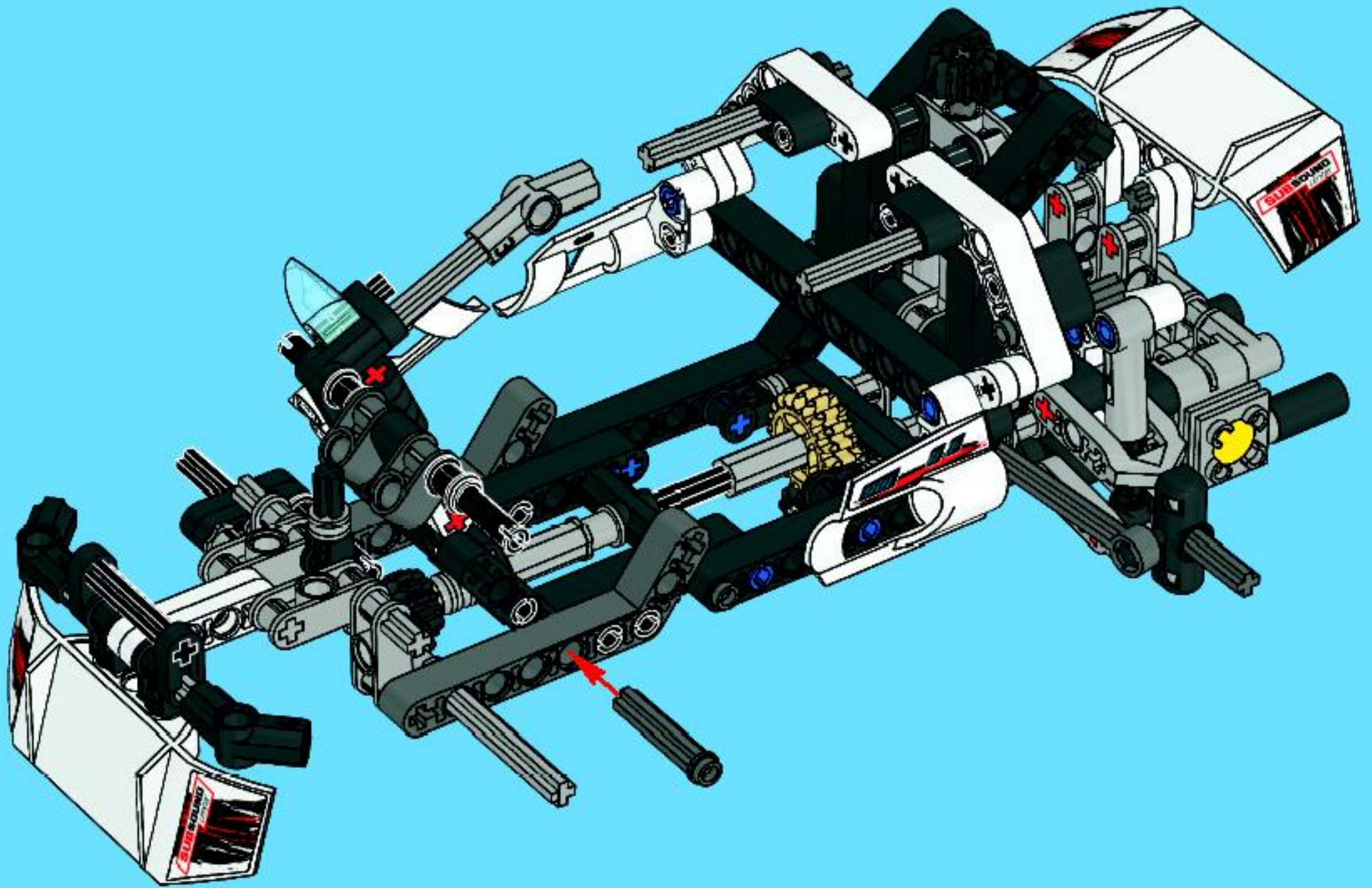



40

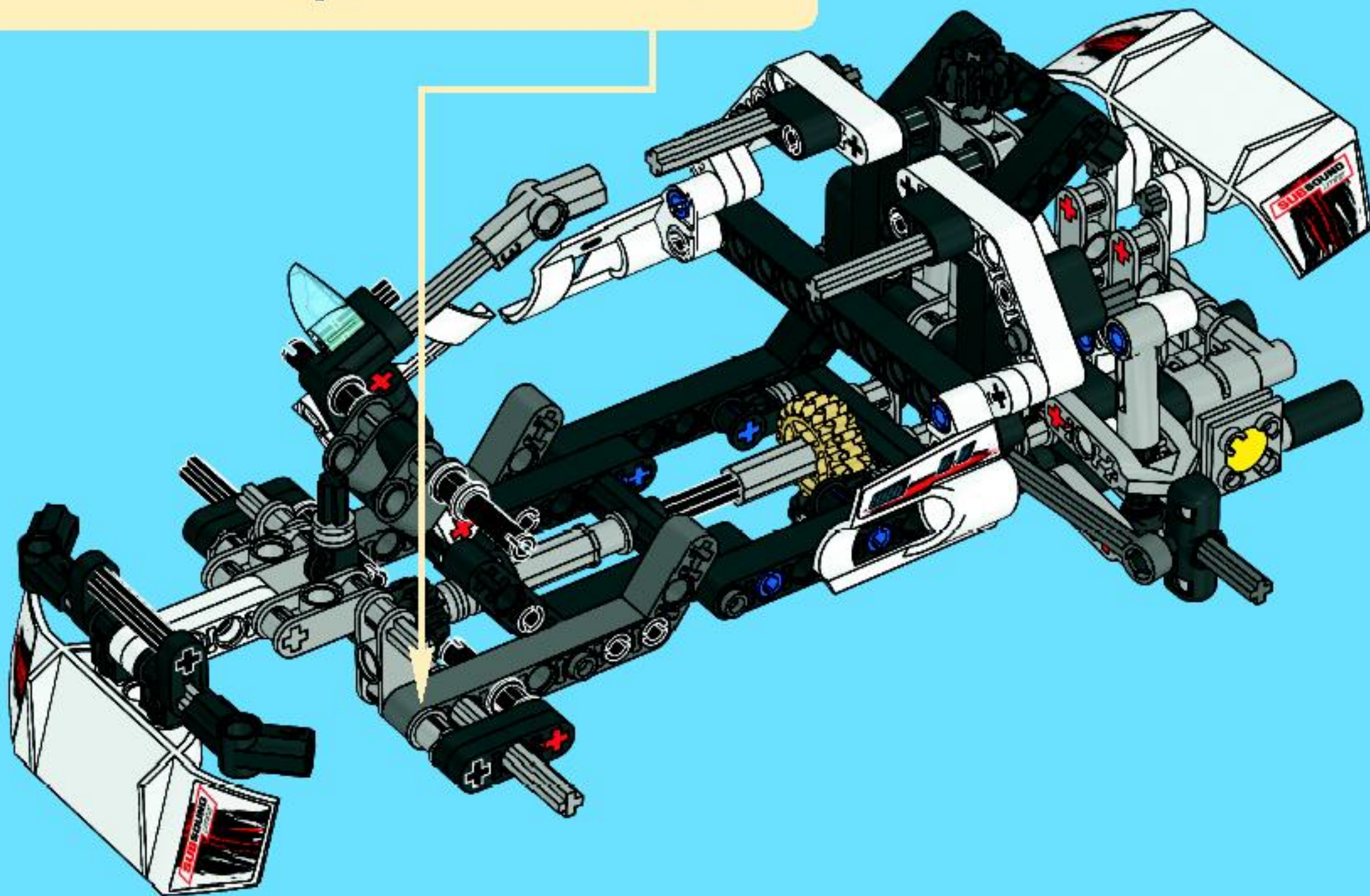
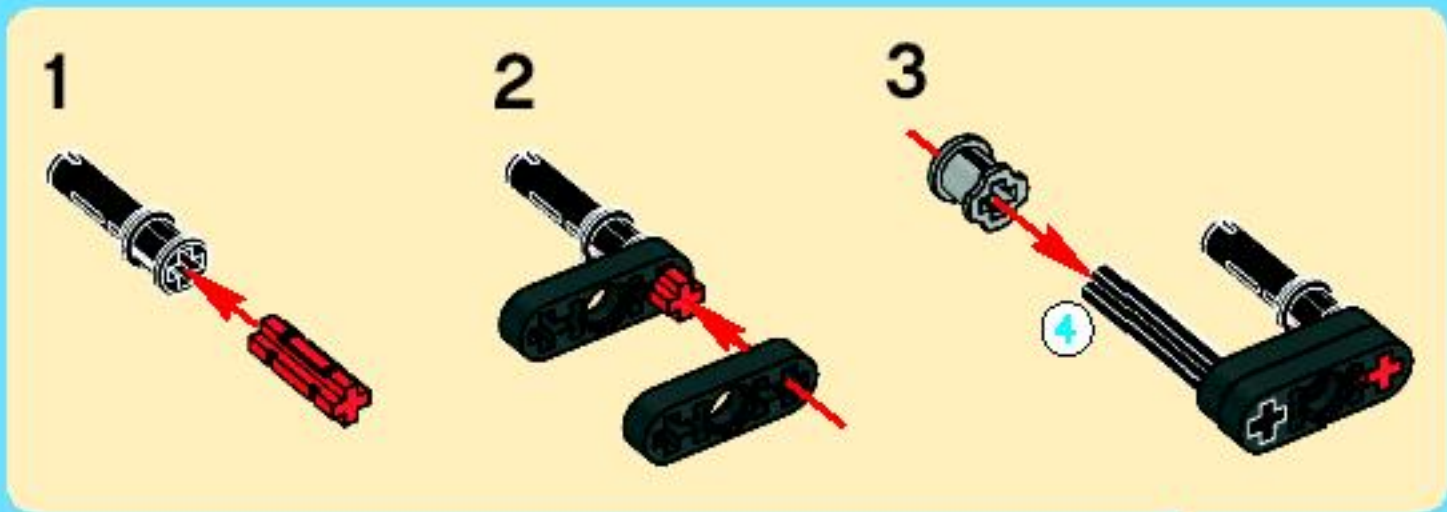

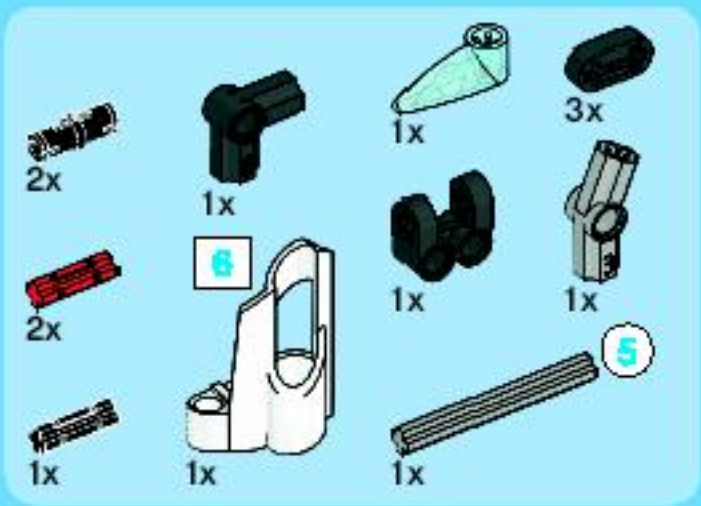

41

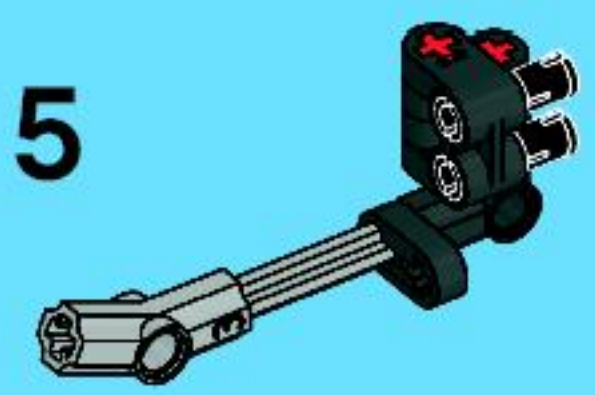
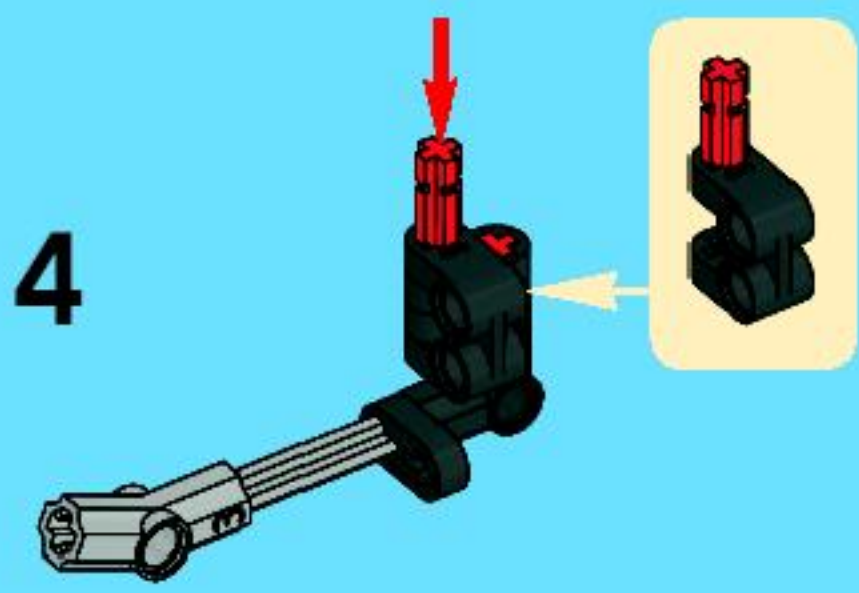
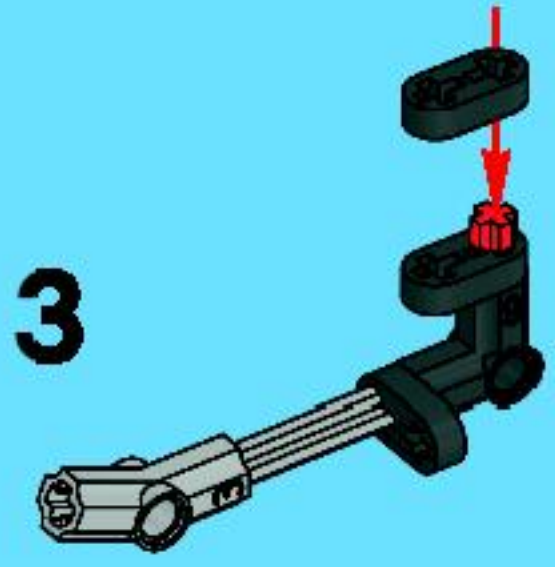
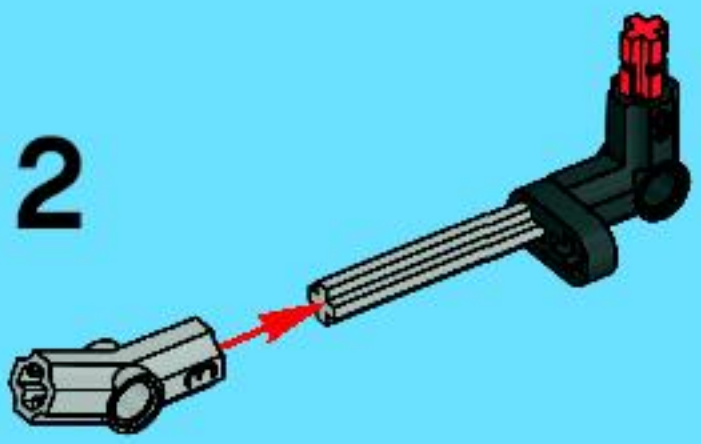
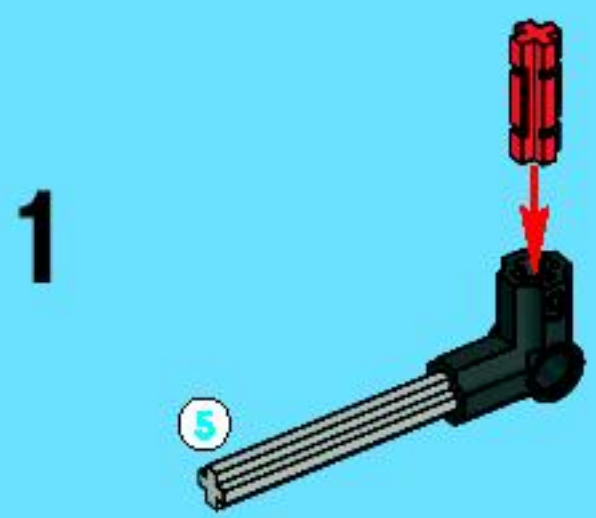

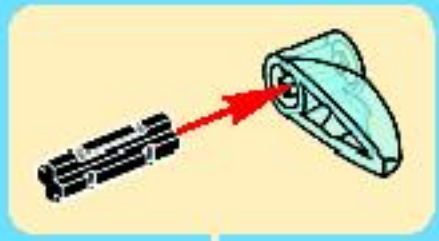

6

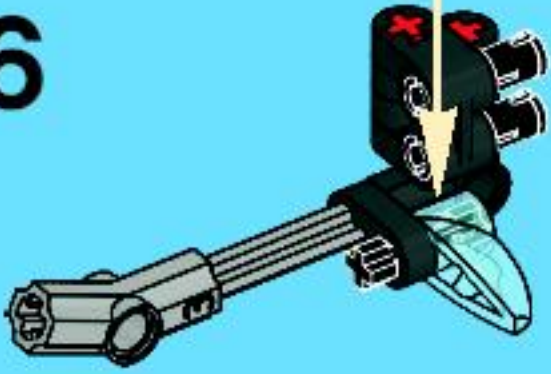

7

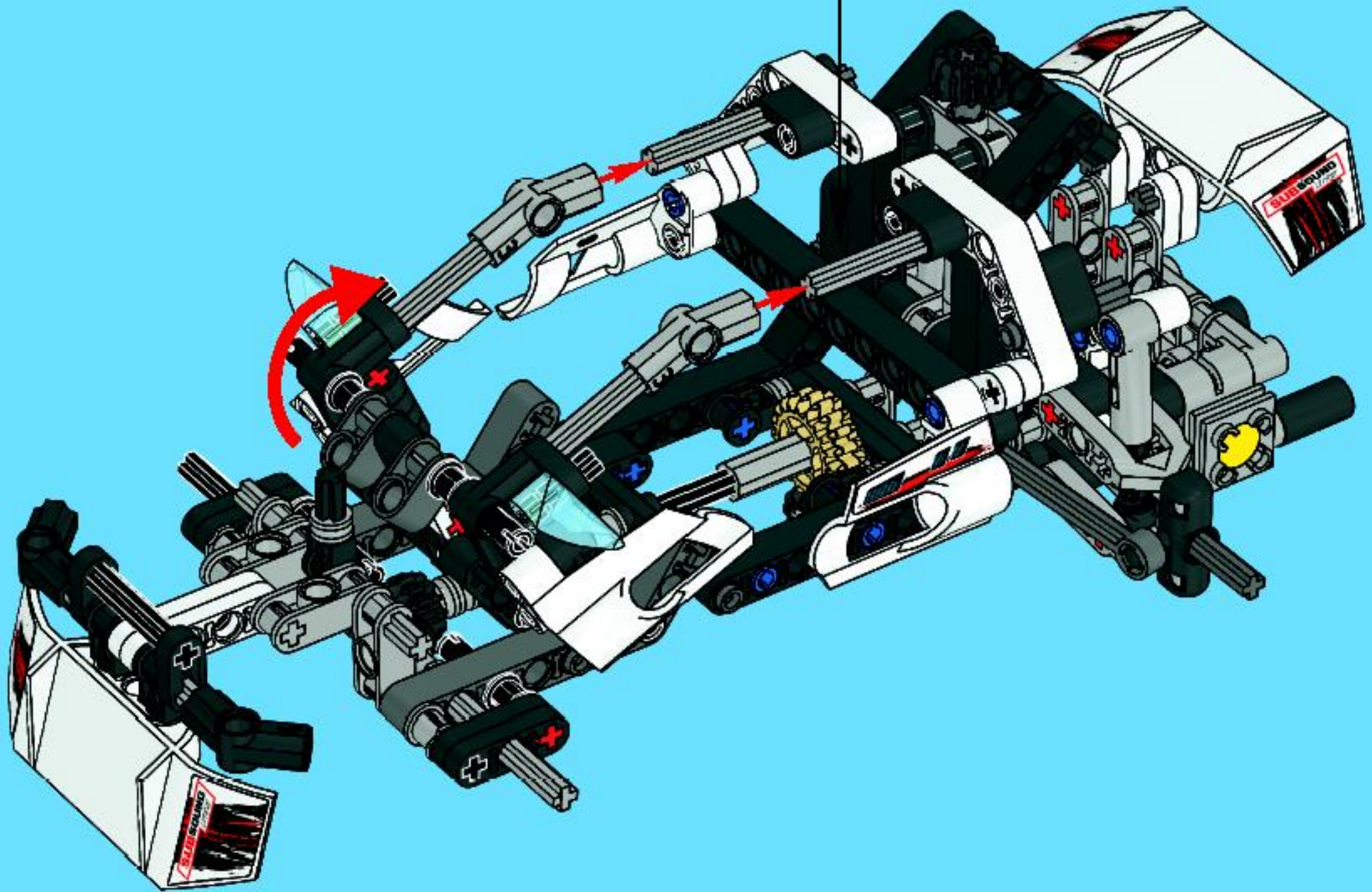
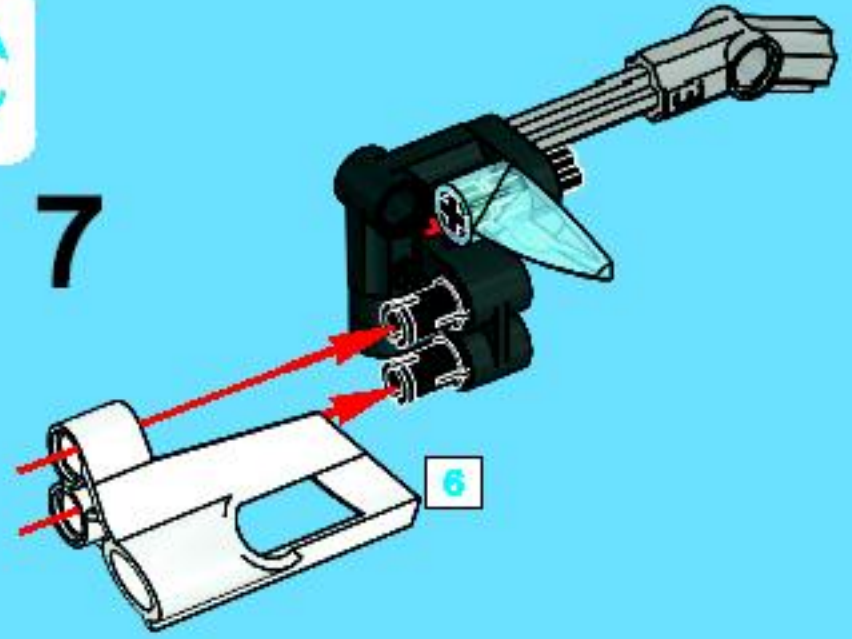



42

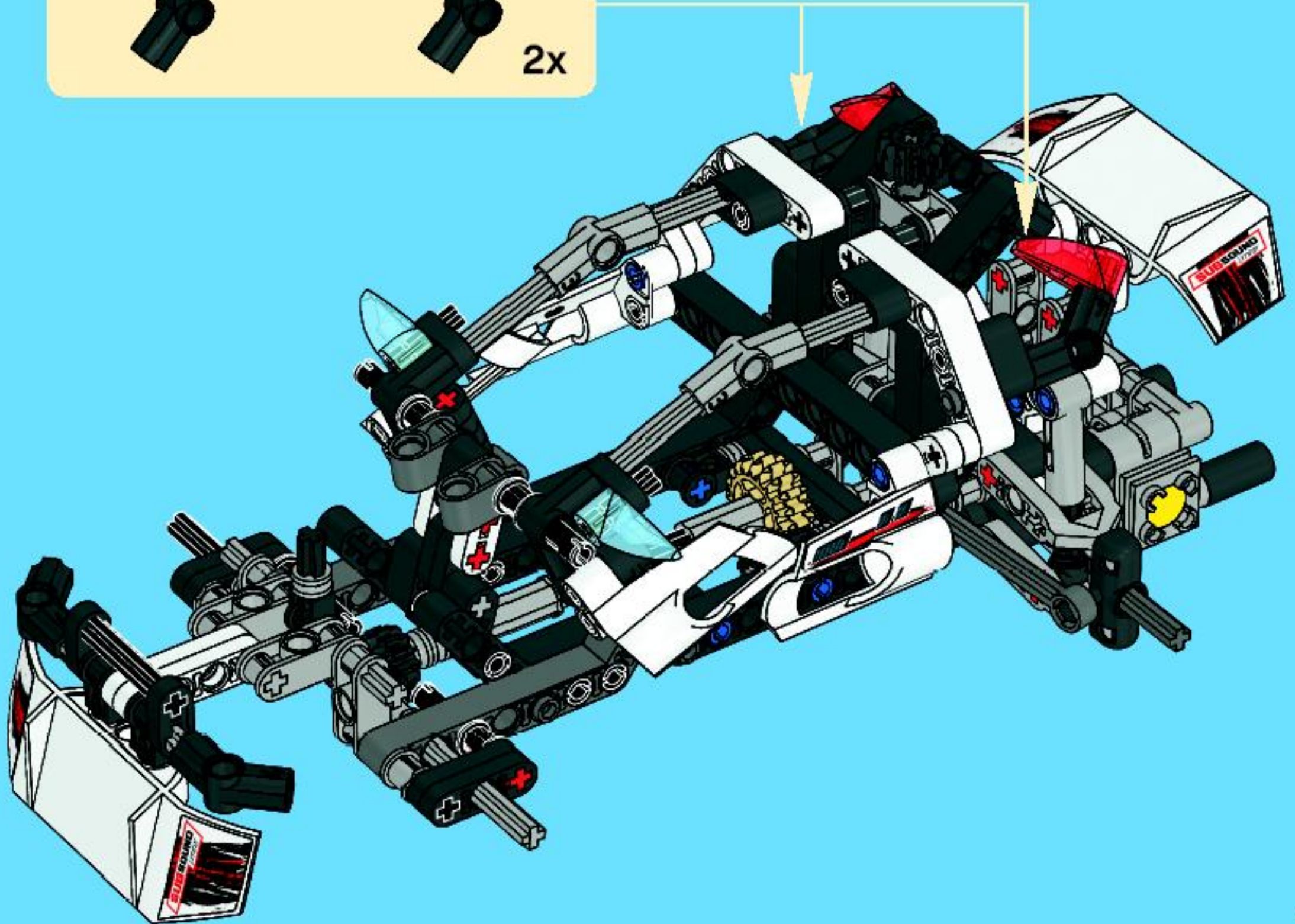
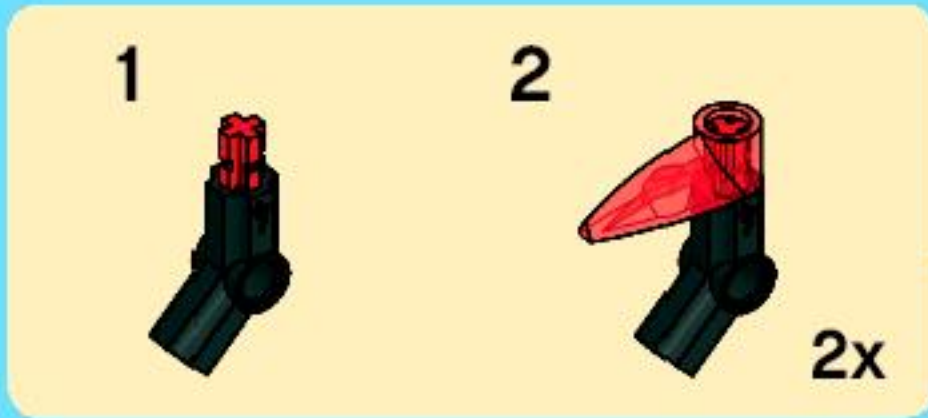

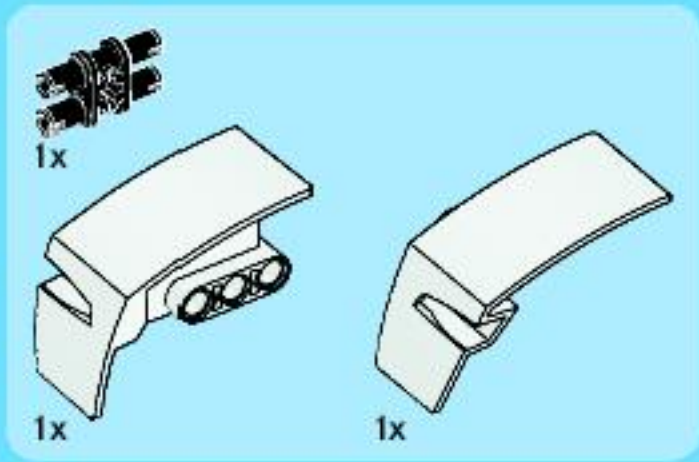

43

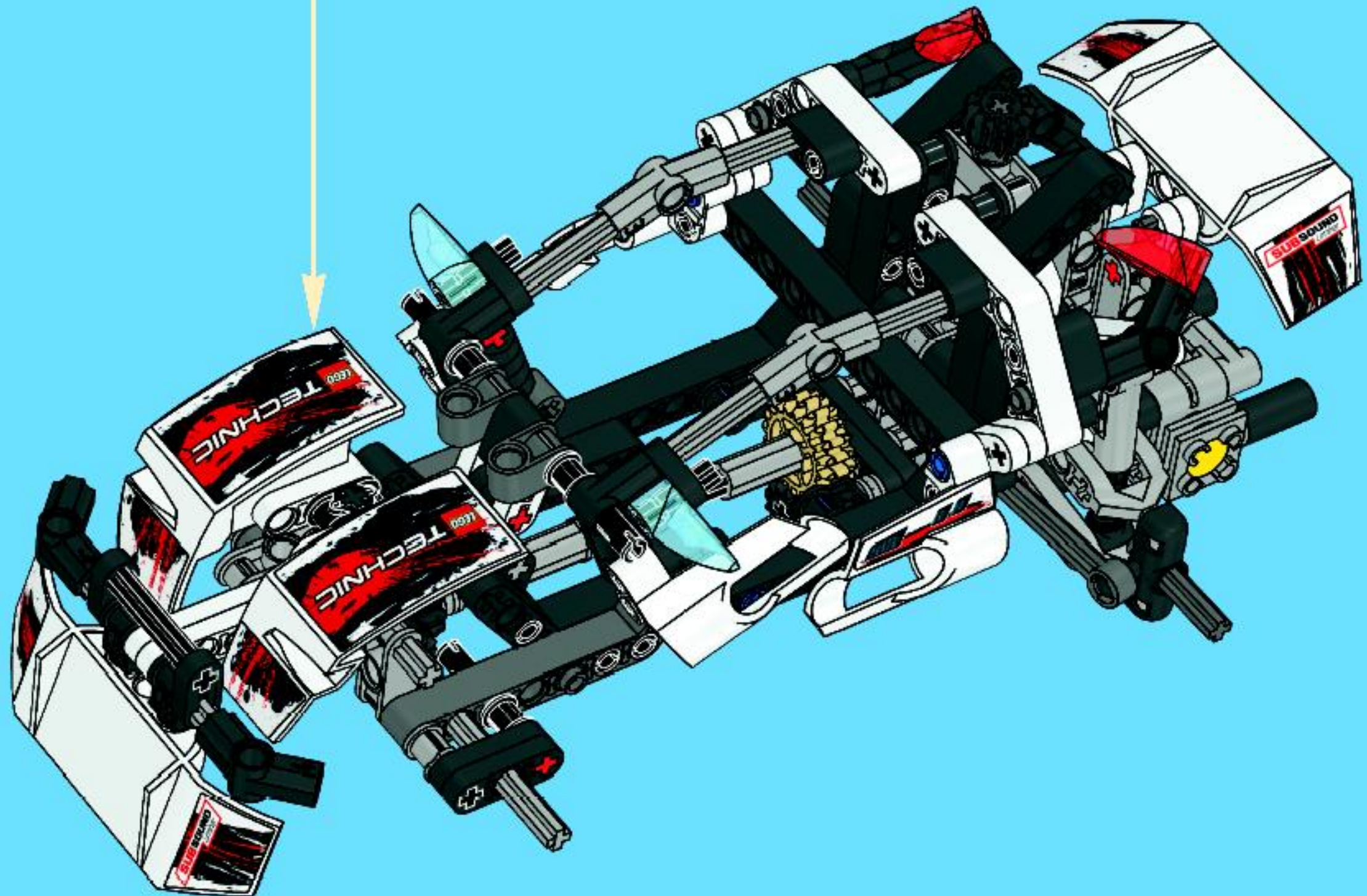
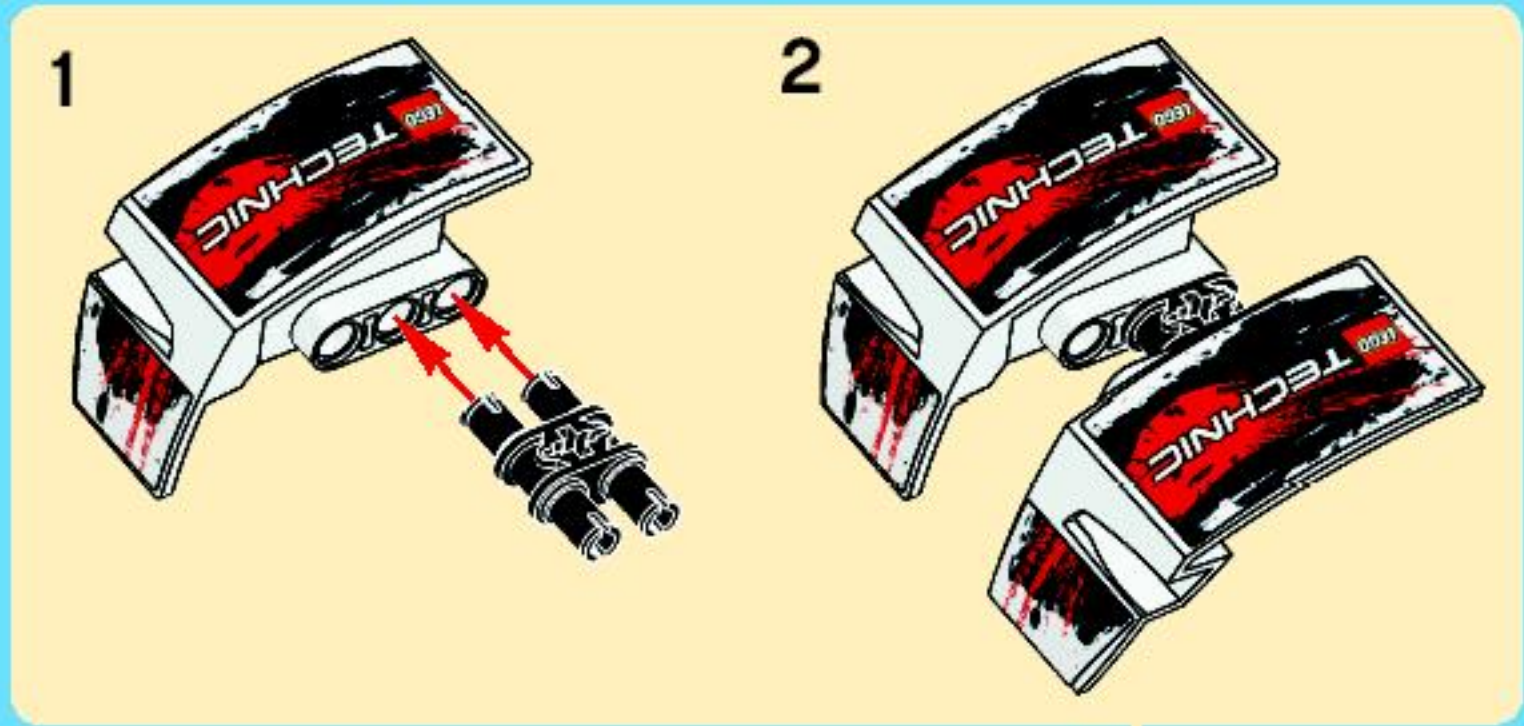

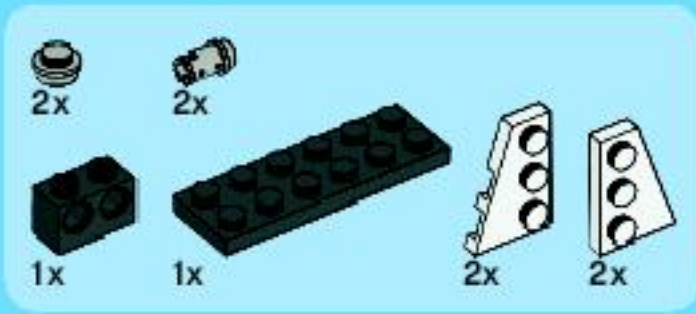

44

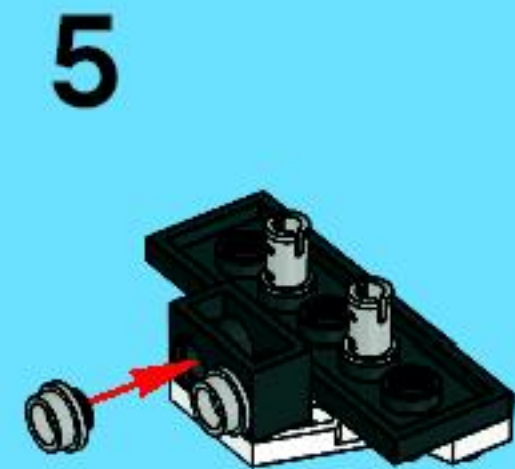
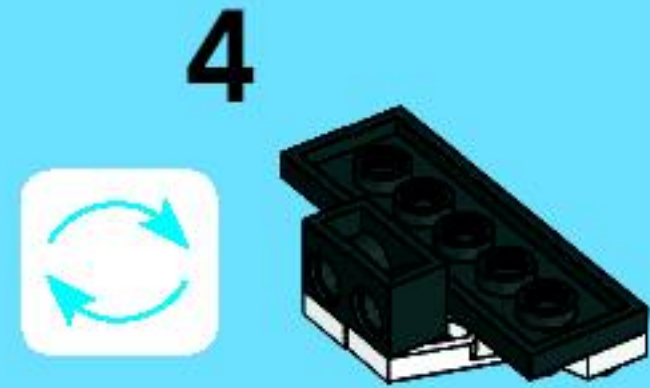
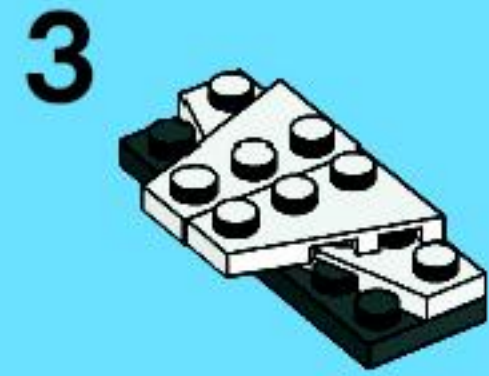
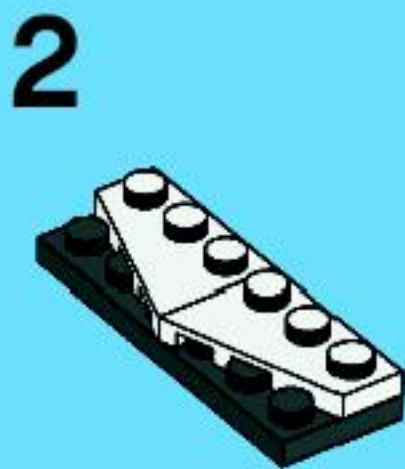
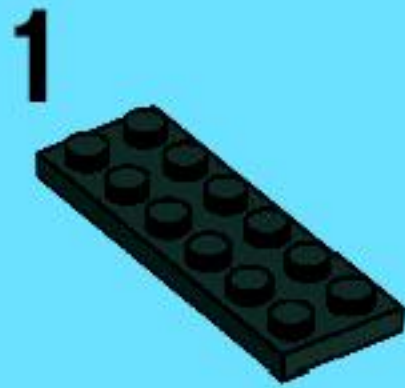

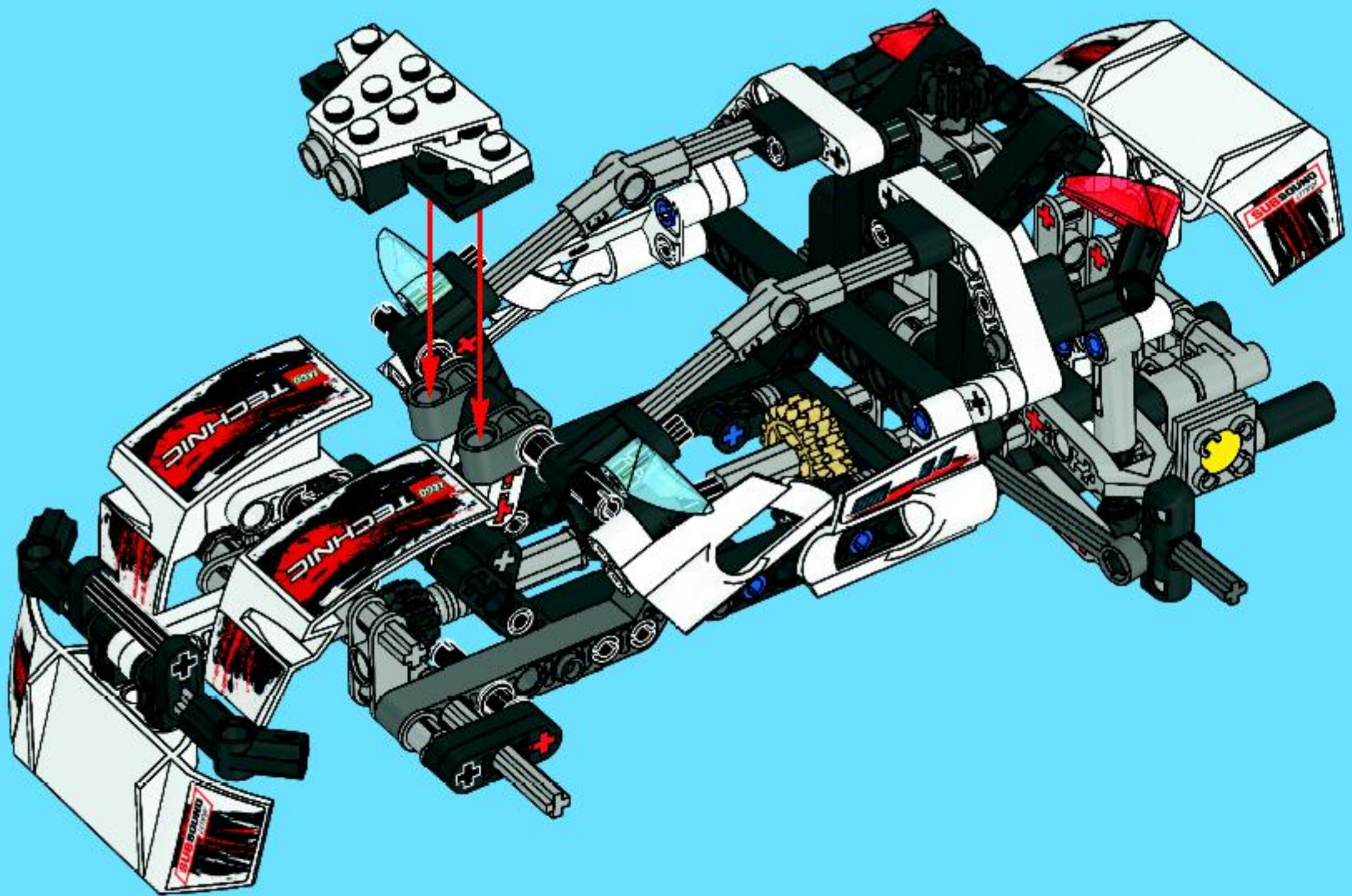

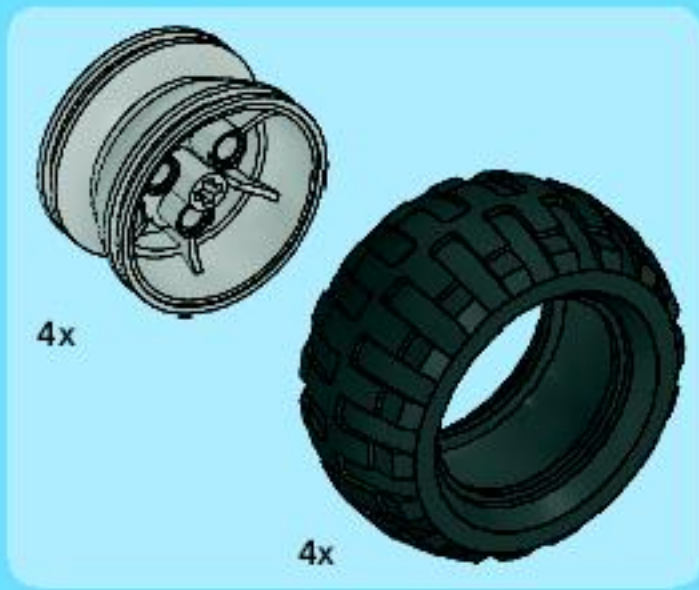

45

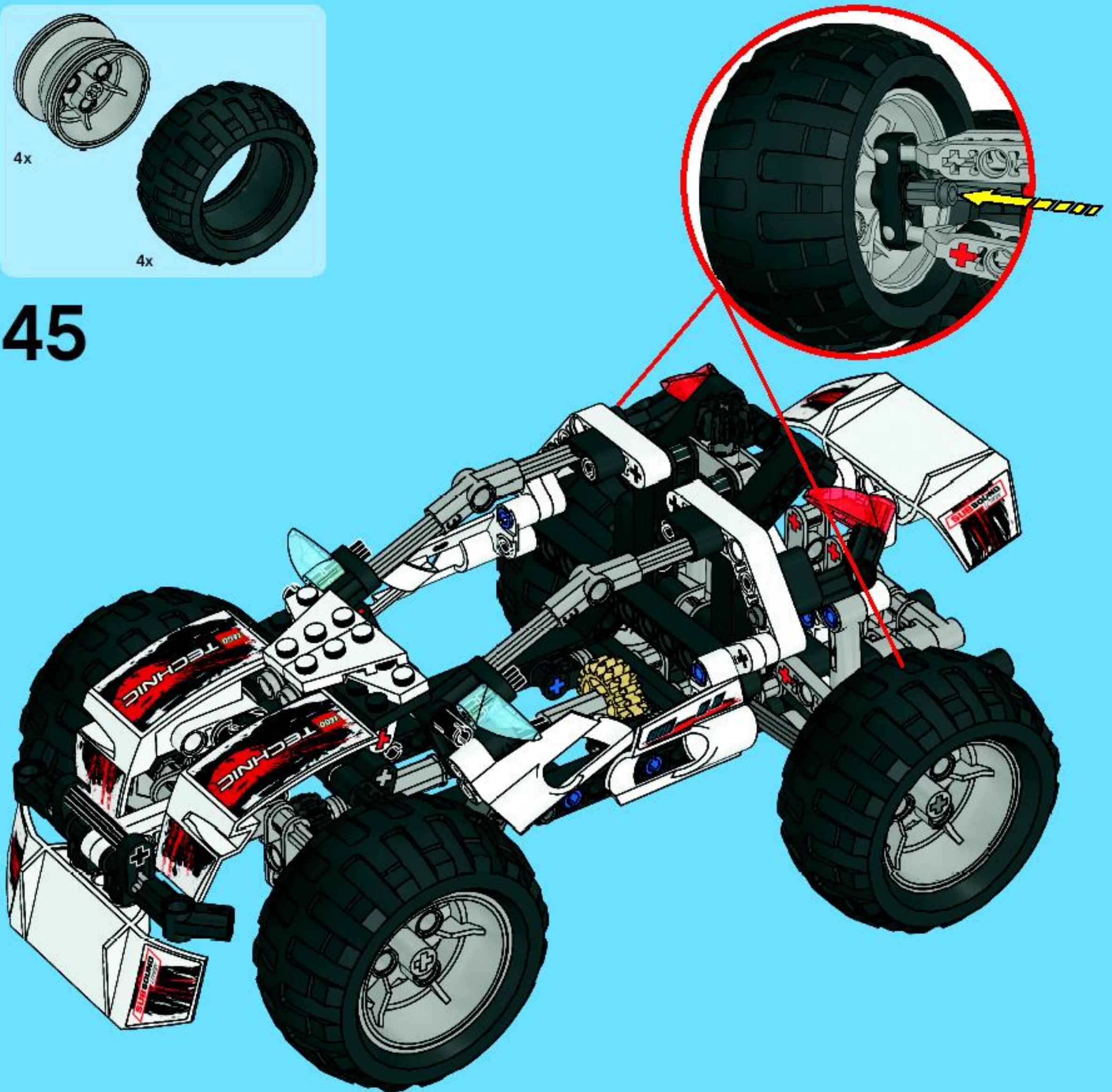



Customer Service
 Kundenservice
 Service Consommateurs
 Servicio Al Consumidor
www.lego.com/service or dial



FREE! GRATIS! GRATUIT!



club MAGAZINE™

www.LEGOclub.com



00800 5346 5555*

1-866-534-6258 • 1-877-518-5346

US & Canada only

Canada seulement



VISIT THE WORLD'S BIGGEST LEGO® SHOP!

www.LEGOshop.com

* Free phone, mobile charges may apply. * Numéro sans frais. Des frais peuvent s'appliquer avec les téléphones cellulaires. * Geldloze Freit. Kosten für Anrufe aus Mobilfunknetzen können anfallen. * Gratis telefonnummer van vaste lijn. * Debet ett gratis nummer, när du ringer från mobiltelefon. * Det är gratis, när du ringer från en fast telefoni.

www.nielsen.com/LEGO



WIN LEGO® PRODUCTS

Fill out a survey and you might WIN a cool LEGO product
NO PURCHASE NECESSARY
Open to all residents where not prohibited
Go to www.nielsen.com/dk/LEGO to fill out a survey for a chance to win a LEGO product.

WIN LEGO® PRODUCTEN

Vul een enquêteformulier in en maak kans op een cool LEGO® product!
Kopen niet nodig
Iedereen uit landen waar geen enquêteverbod geldt mag deelnemen.
Ga naar www.nielsen.nl/dk/LEGO, vul een enquêteformulier in en maak kans op een LEGO product.

GEWINNE LEGO® PRODUKTE

Nimm an der Umfrage teil und GEWINNE ein tolles LEGO® Produkt!
Die Teilnahme am Gewinnspiel führt zu keinerlei Kaufverpflichtungen
Teilnahme in allen nicht ausgeschlossenen Ländern möglich
Wir verlosen unter allen Teilnehmern der Umfrage auf www.nielsen.nl/dk/LEGO LEGO Produkte.

GAGNE DES PRODUITS LEGO®

Réponds à un questionnaire et tu pourrais GAGNER un produit LEGO® très cool !
Aucune obligation d'achat.
Ouvert à tous les résidents des pays autorisés.
Visite www.nielsen.nl/dk/LEGO pour répondre à un questionnaire et avoir une chance de gagner un produit LEGO.

レゴ®製品を「当てよう」

アンケートに記入して、かっこいいレゴ®製品を当てよう！
お買い上げの必要はありません。
禁止されていない限り、すべての皆様にご利用いただけます。
www.nielsen.com/dk/LEGOにアクセスして、アンケートにご記入ください。当選者にはレゴ®製品を差し上げます。



 www.LEGO.com