

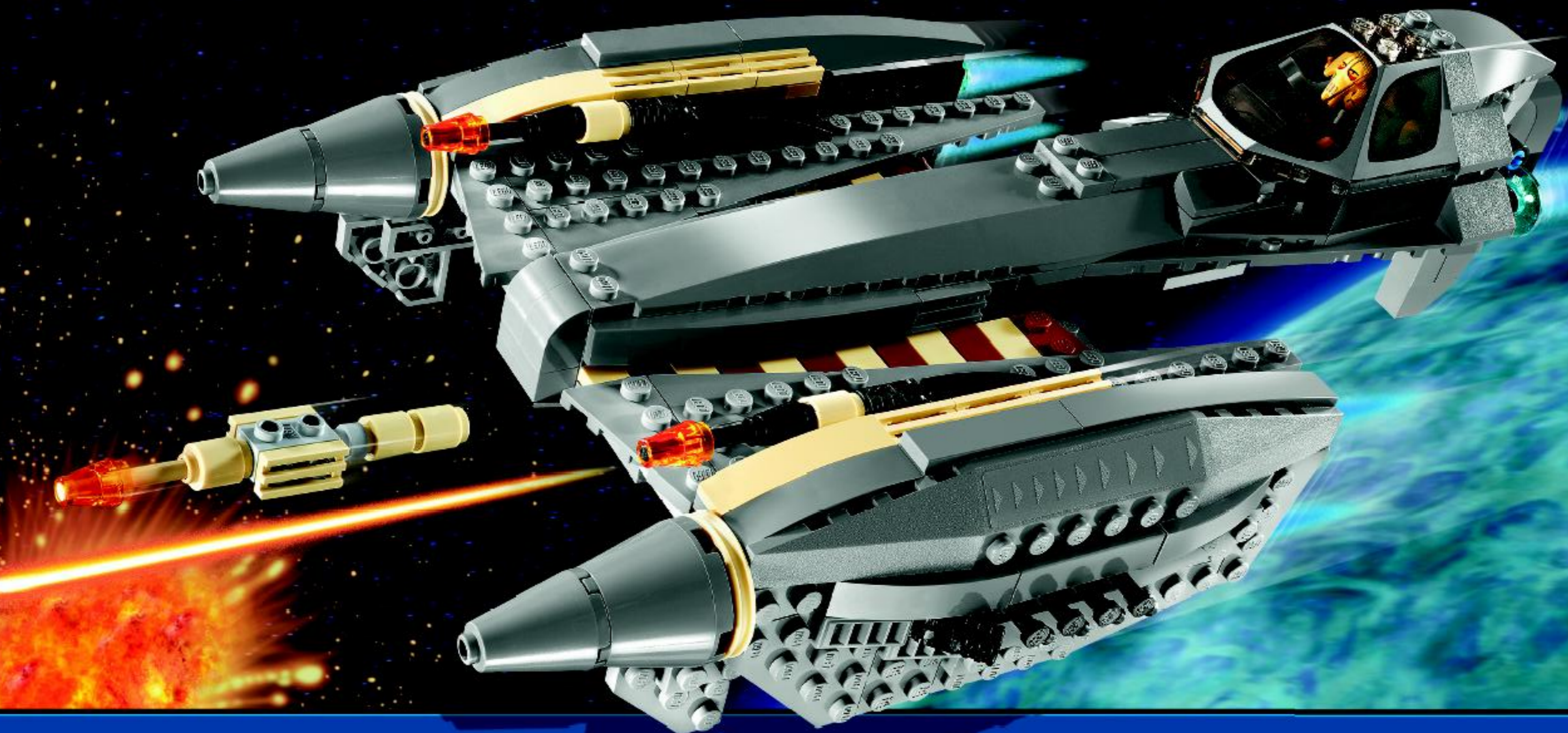

STAR WARS



8095



1

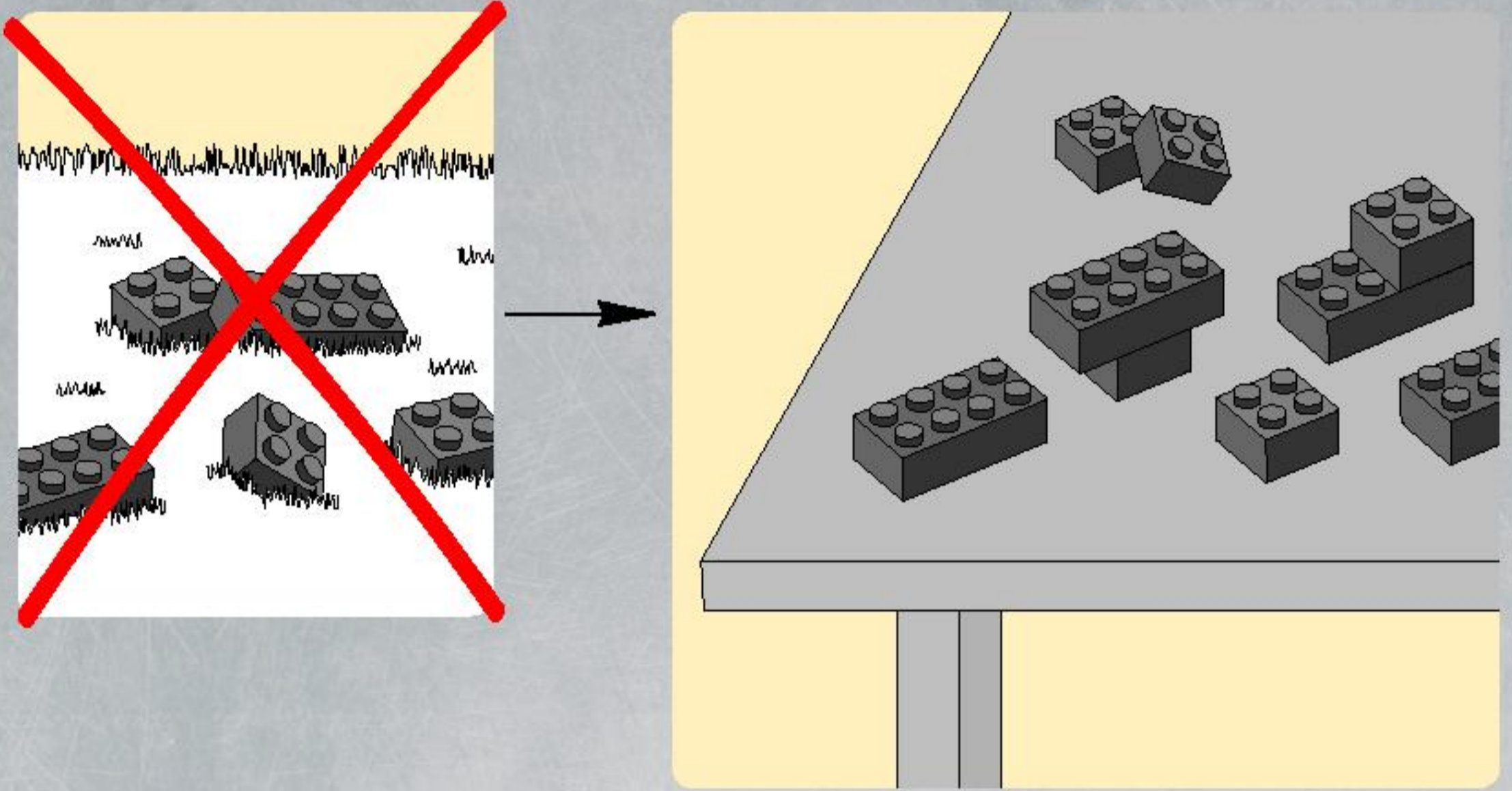

2



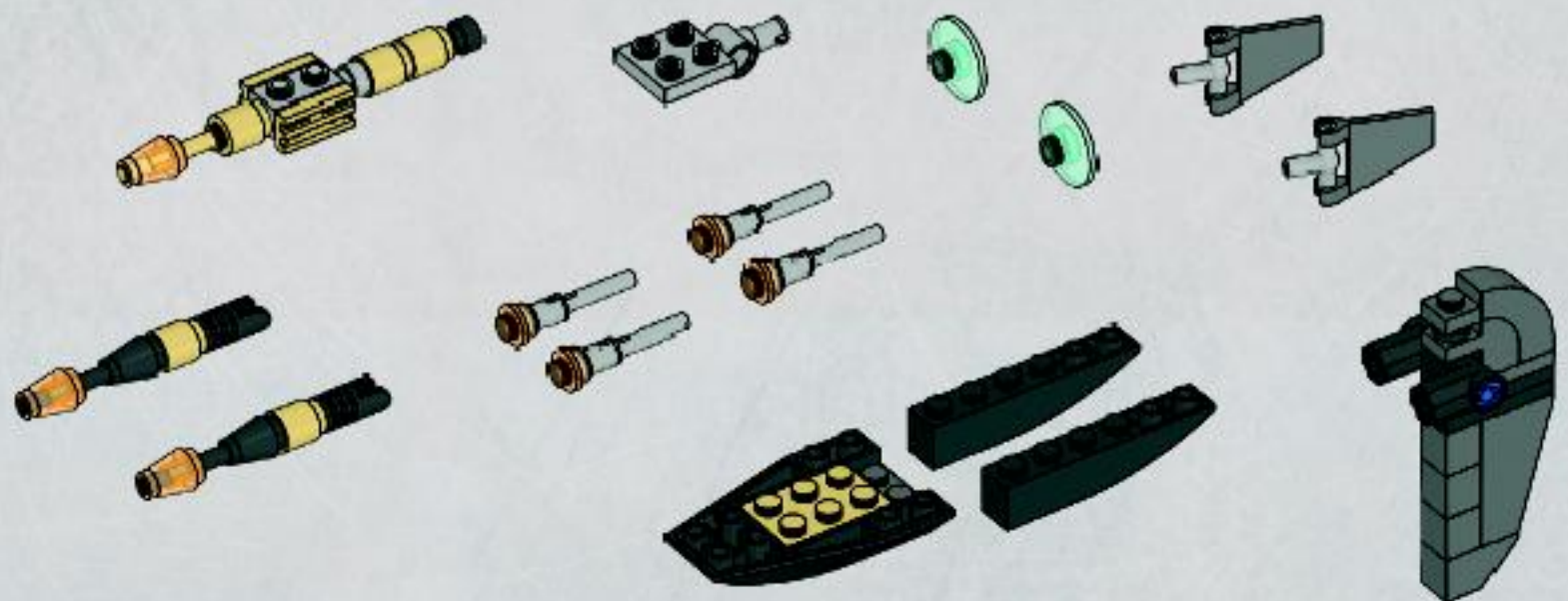
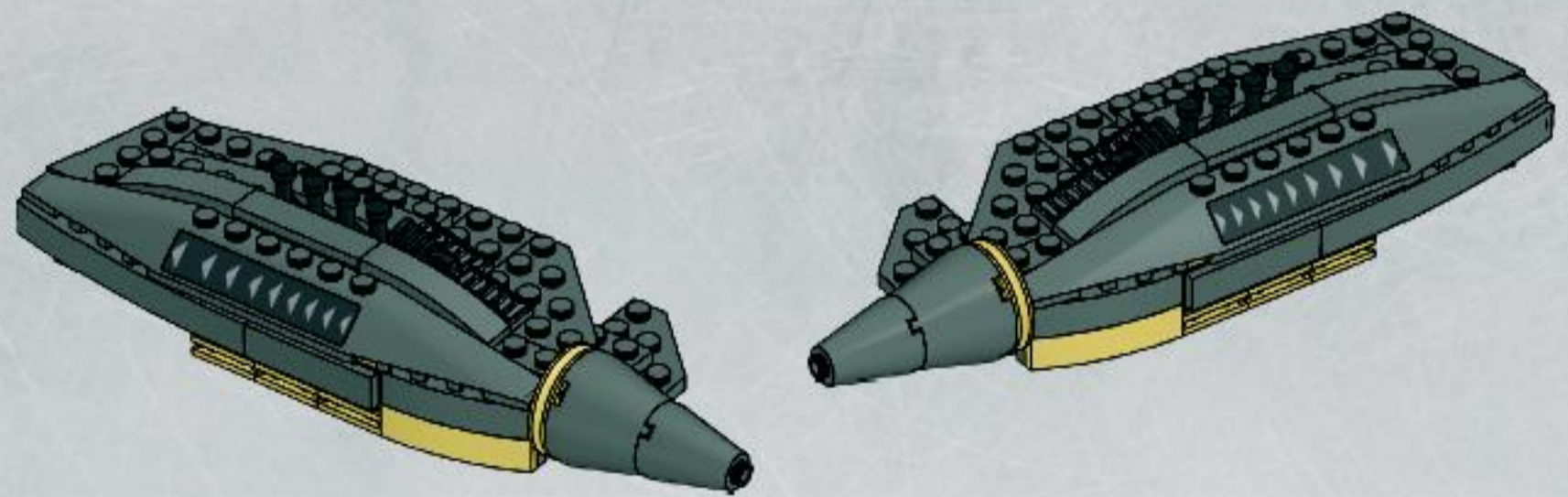
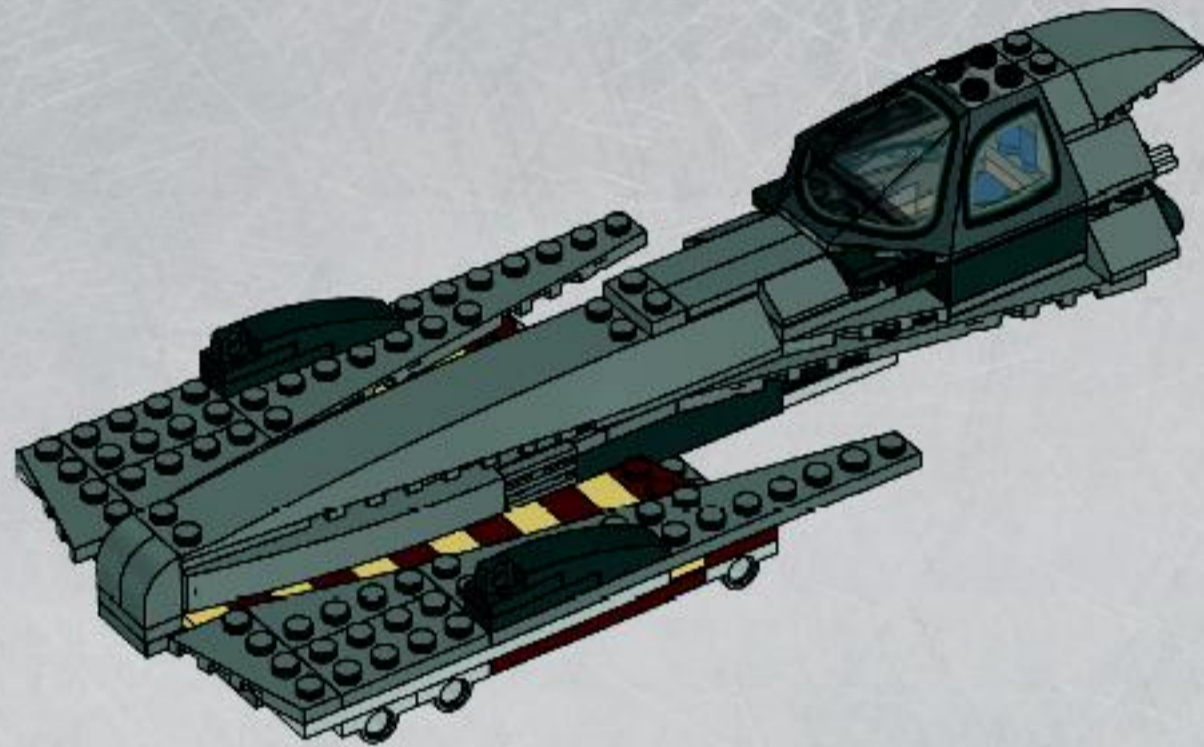



1



2

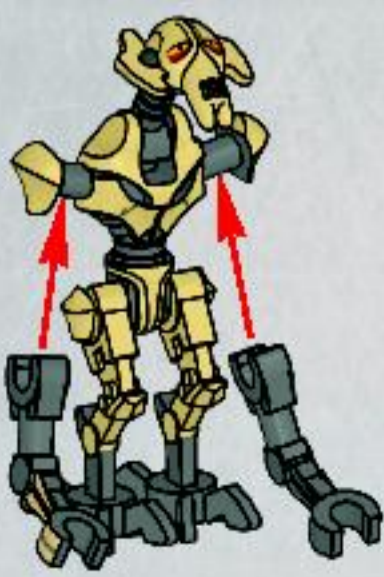

3

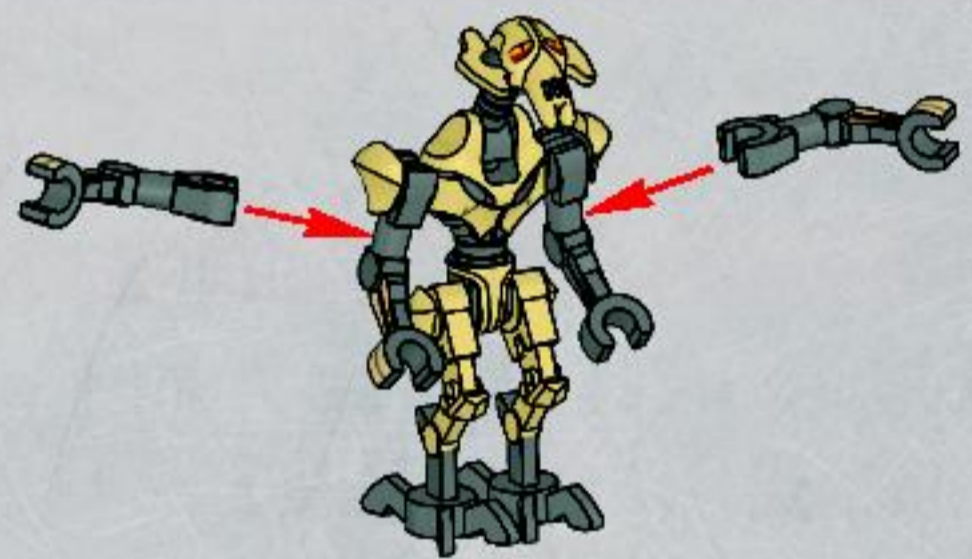

4



1

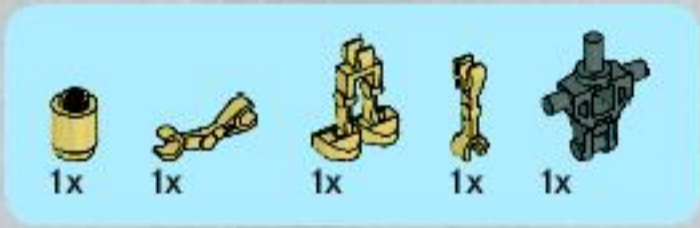
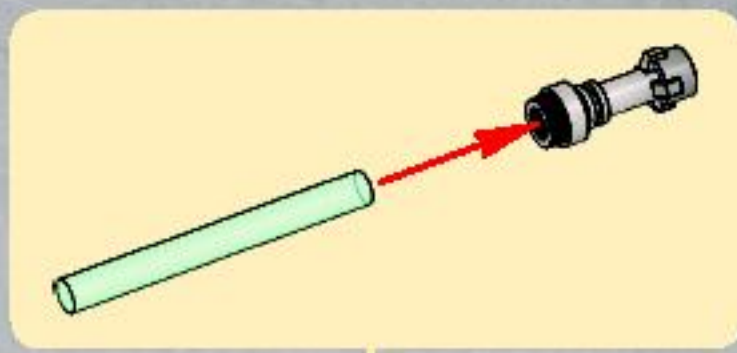
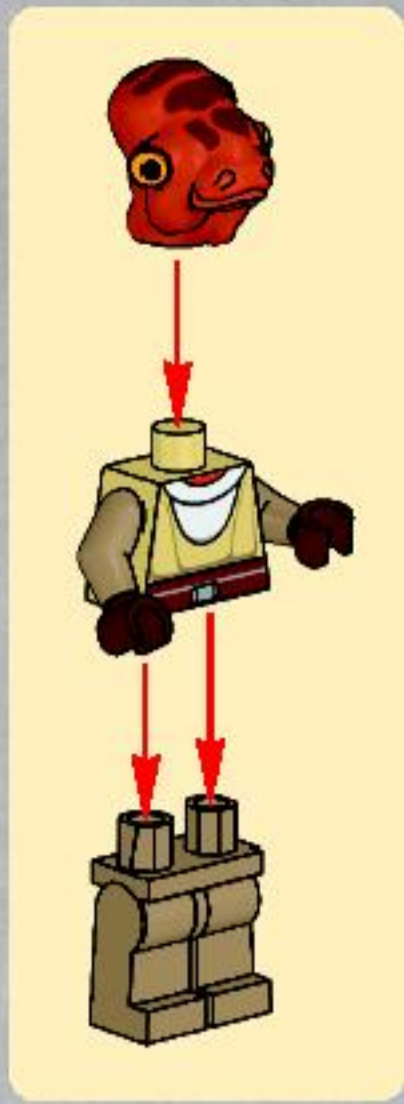

1

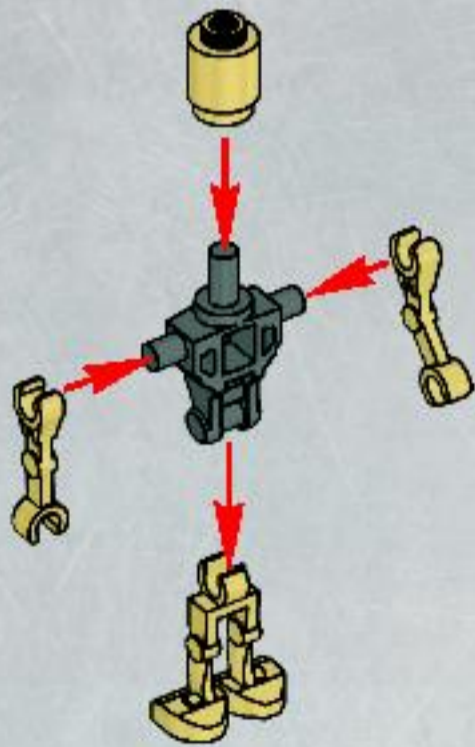

2

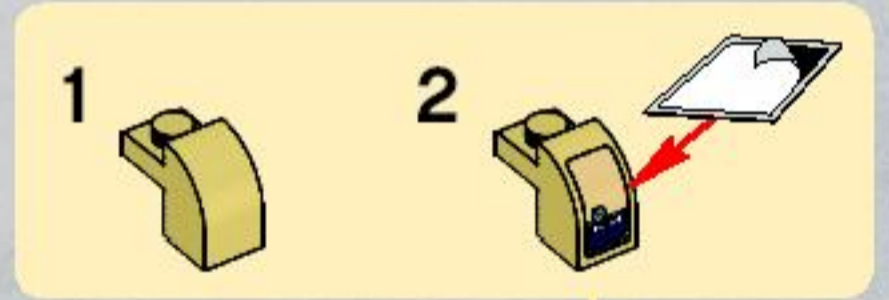

3





4

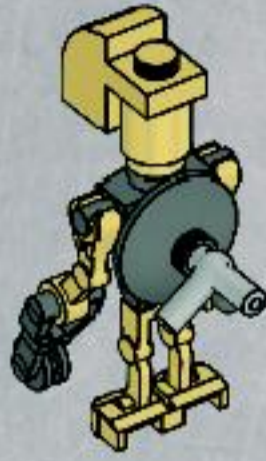

5

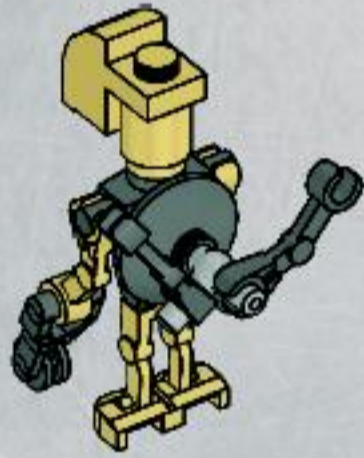

6

1



2

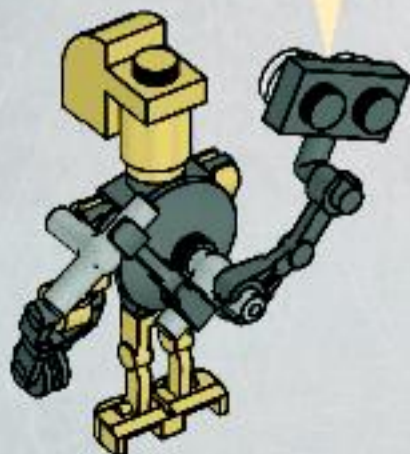

7

1



2



8





1



2

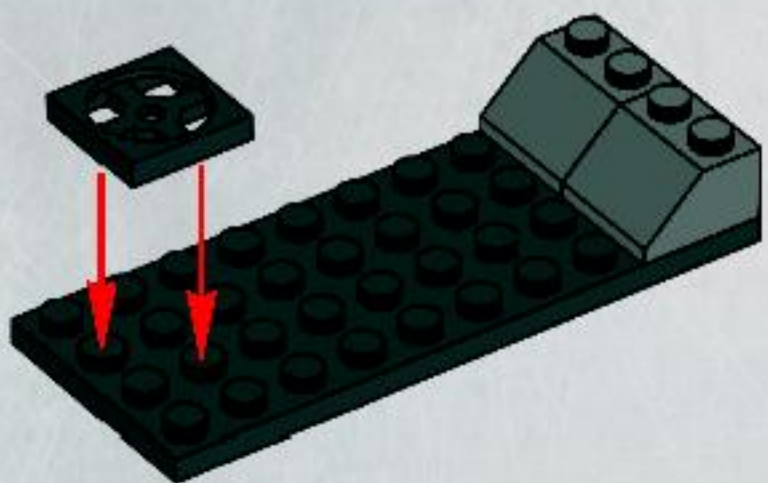

3

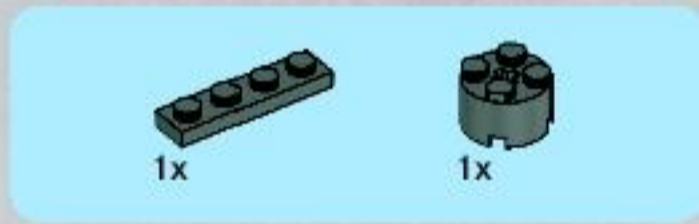
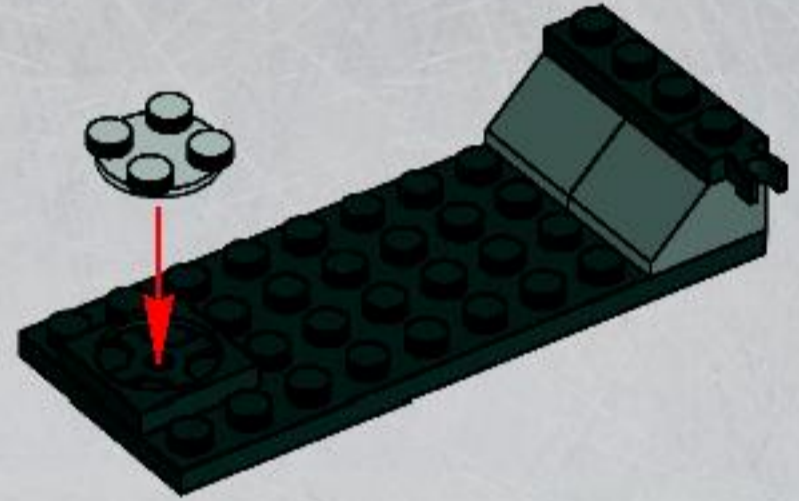

4

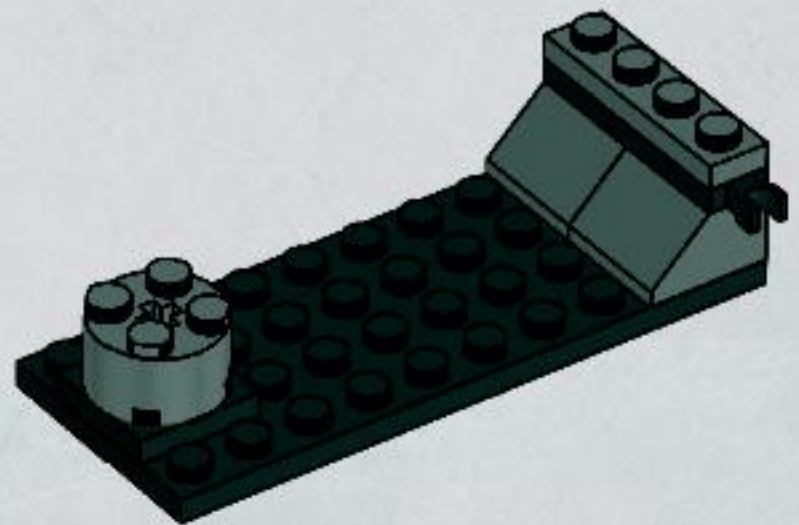



2x



2x

5

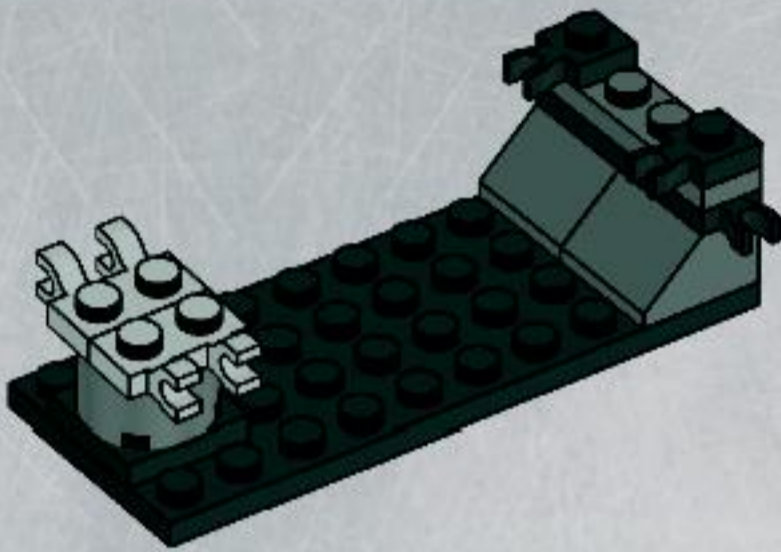

1x



2x



1x

7

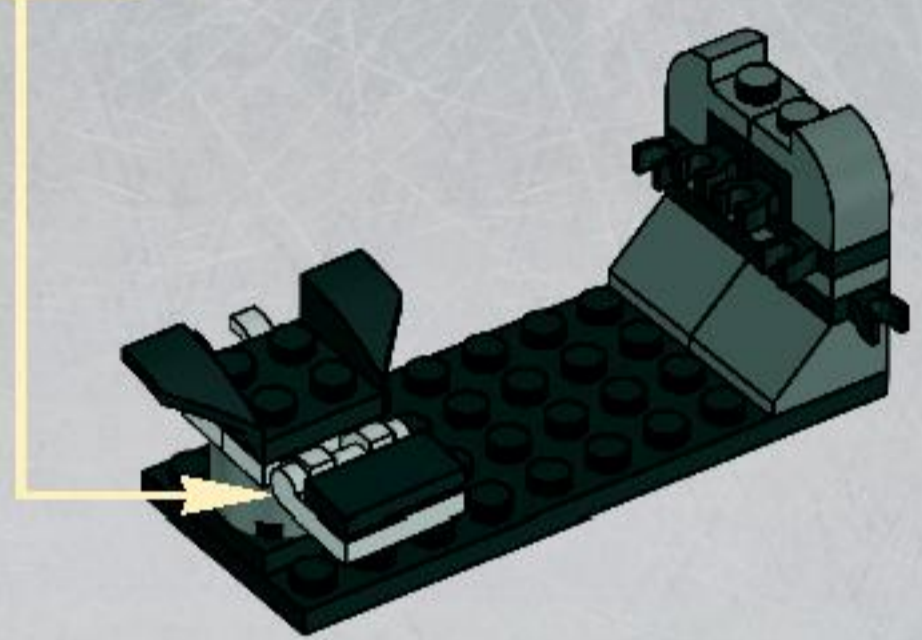
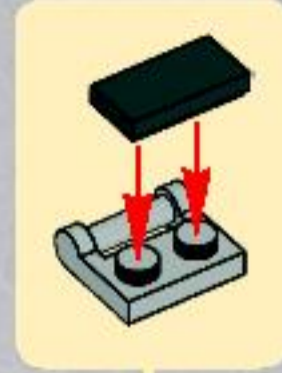

1x



2x

6

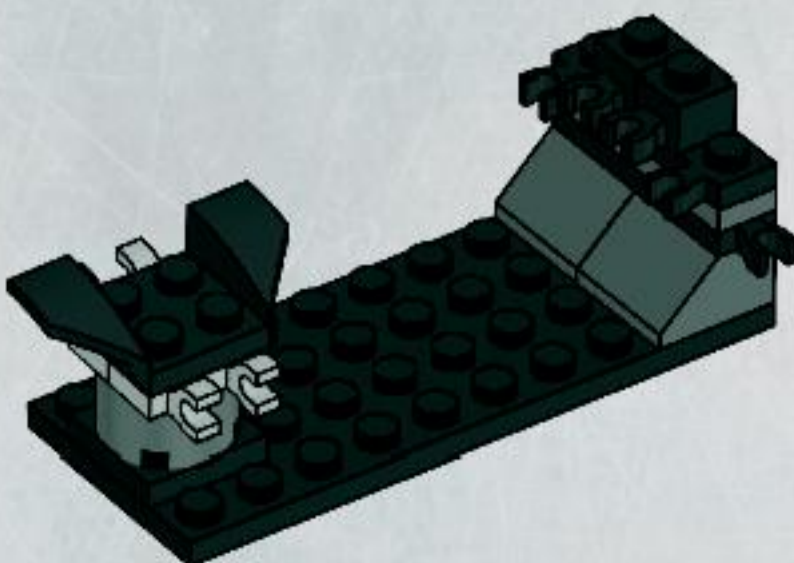

1x



1x

8

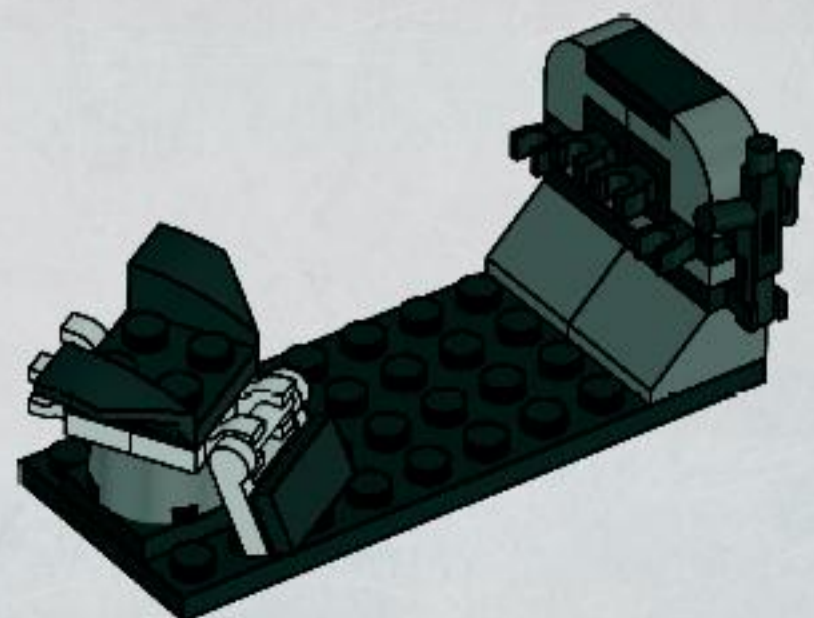



9

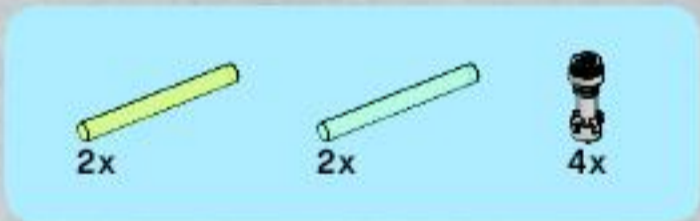
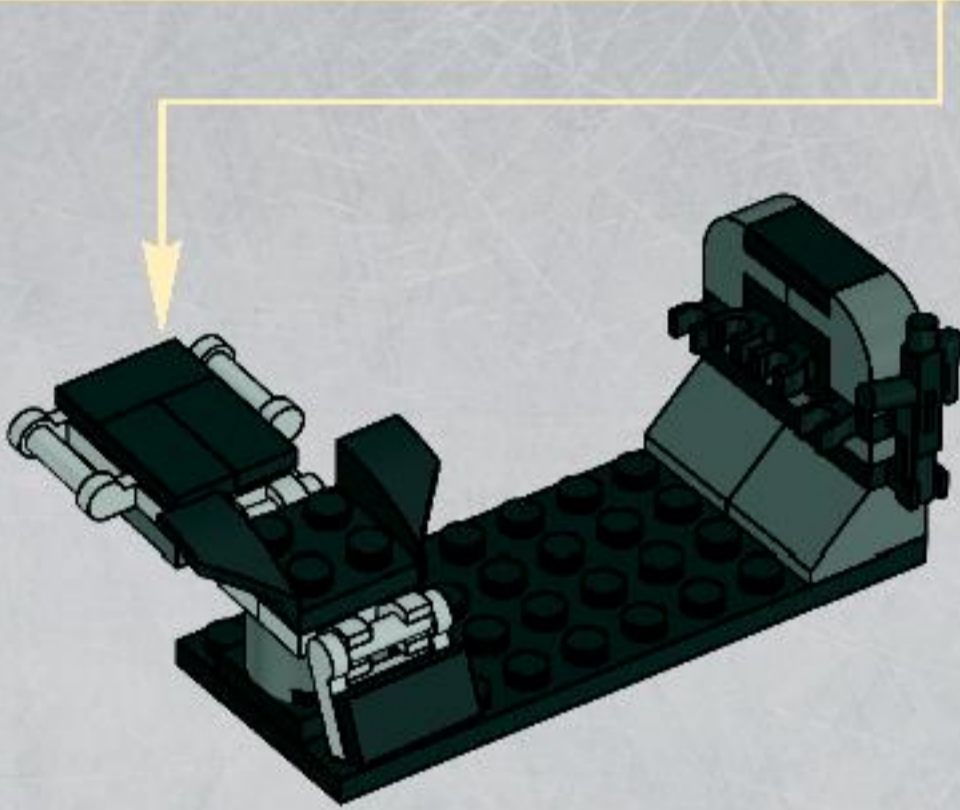
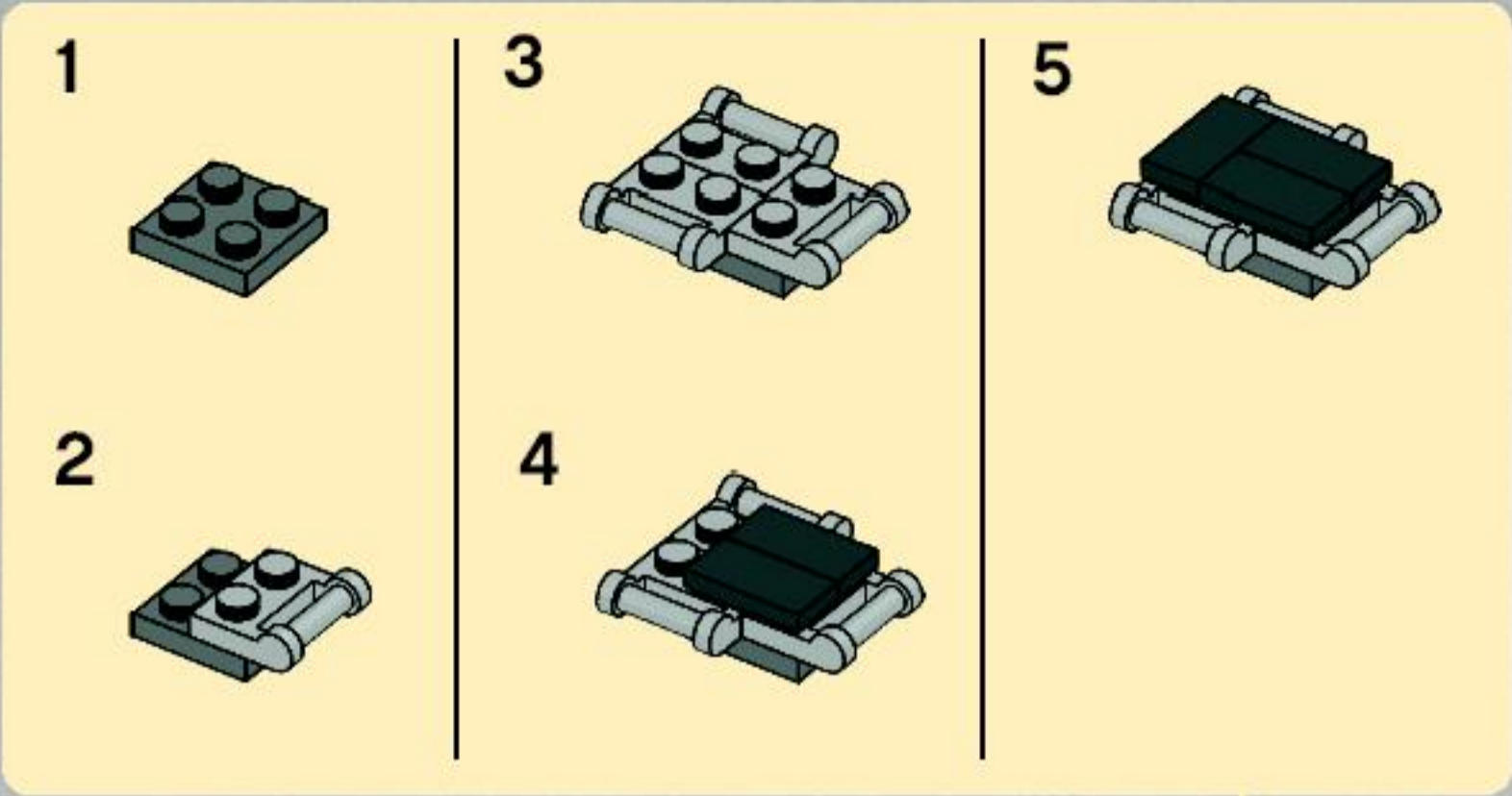

10

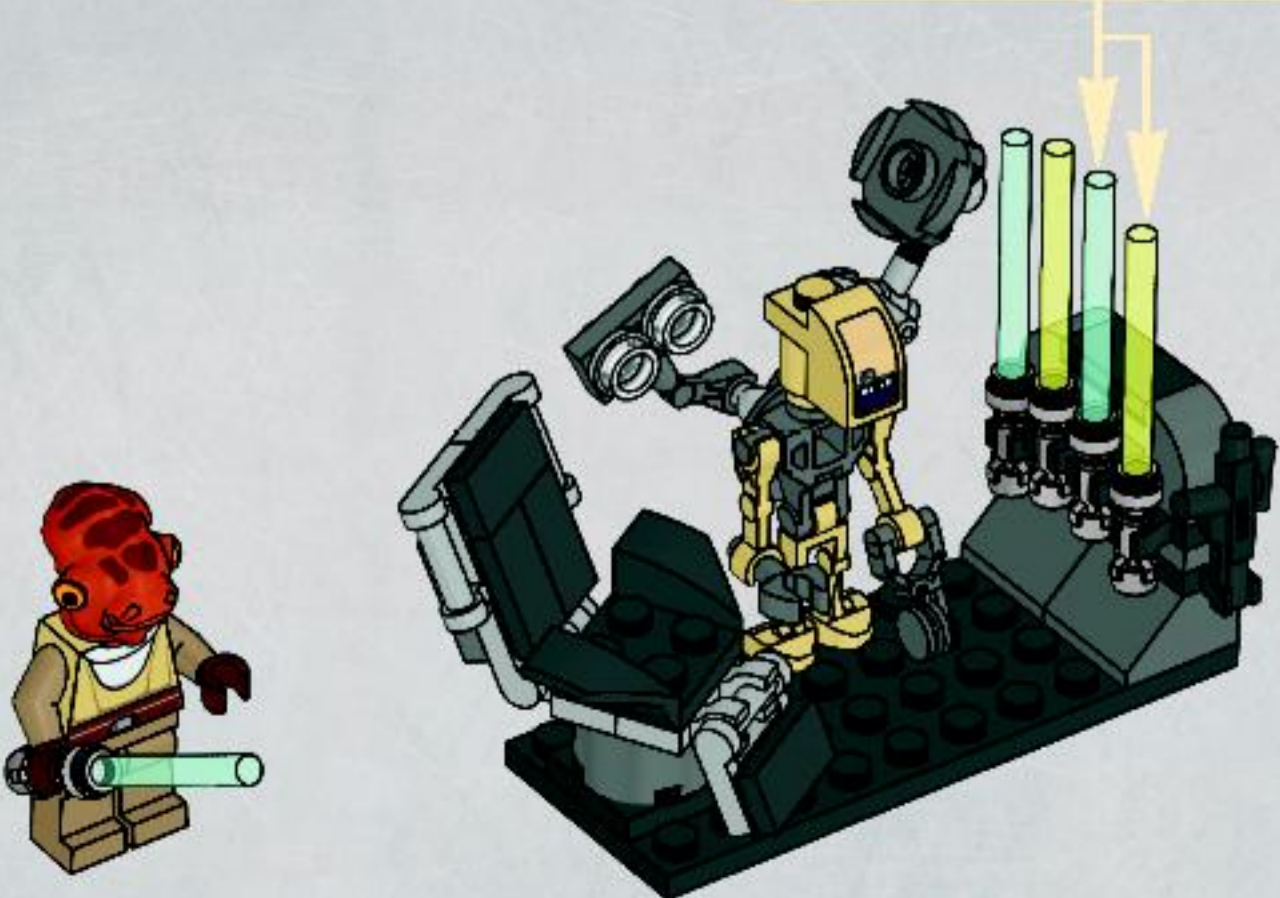
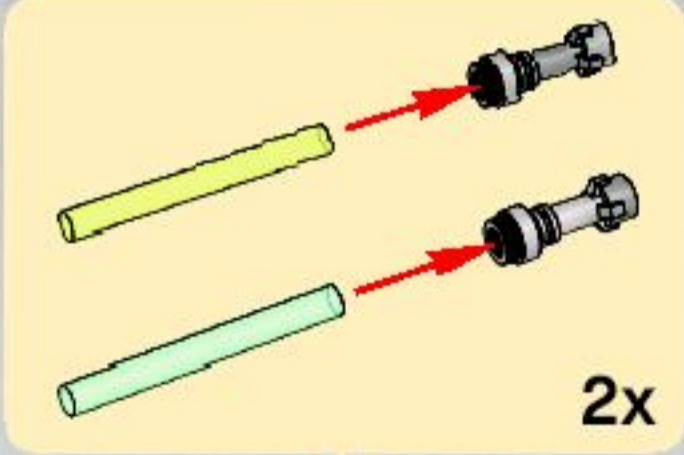

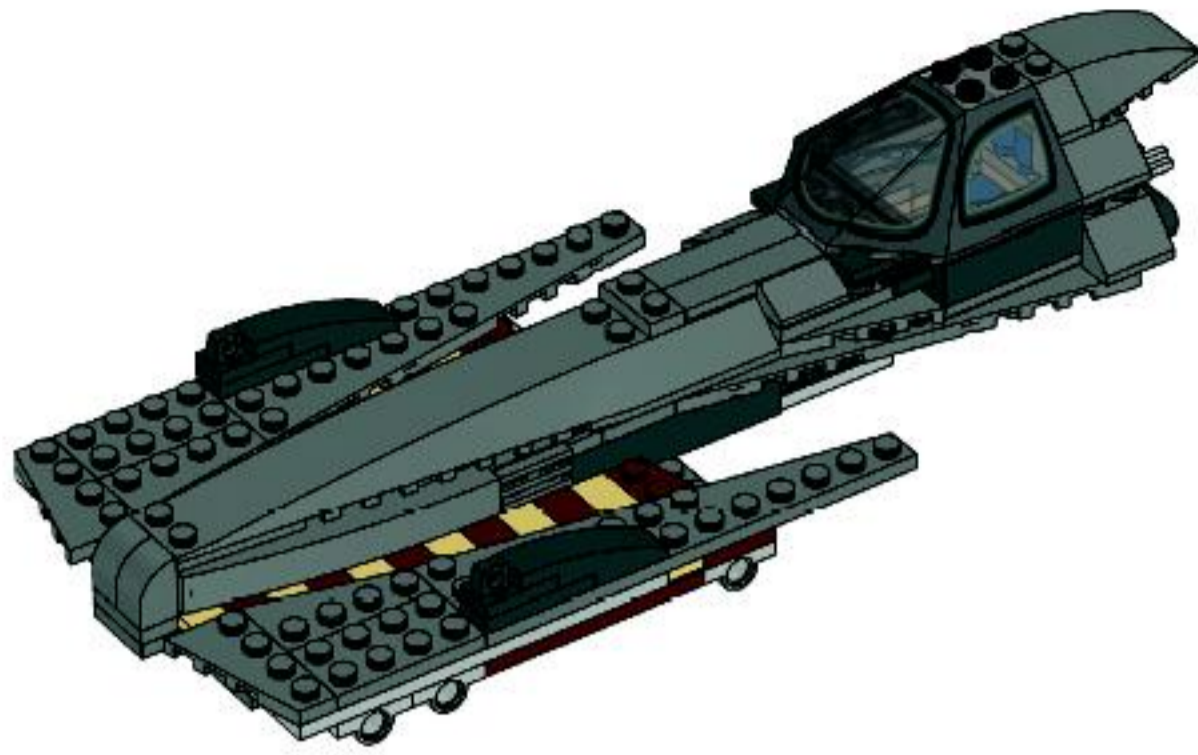

1x

1

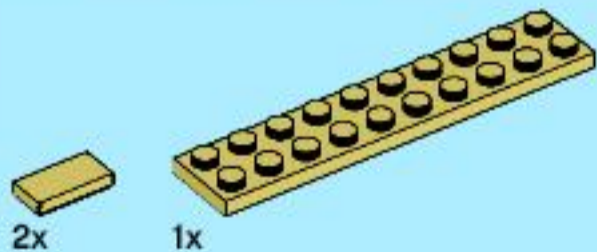
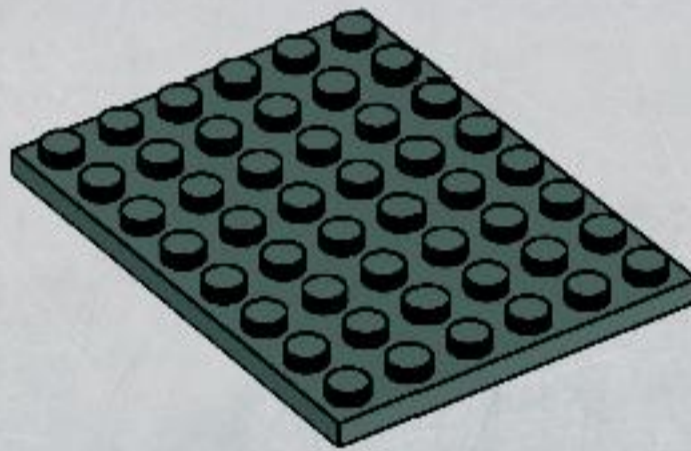

2x

1x

2

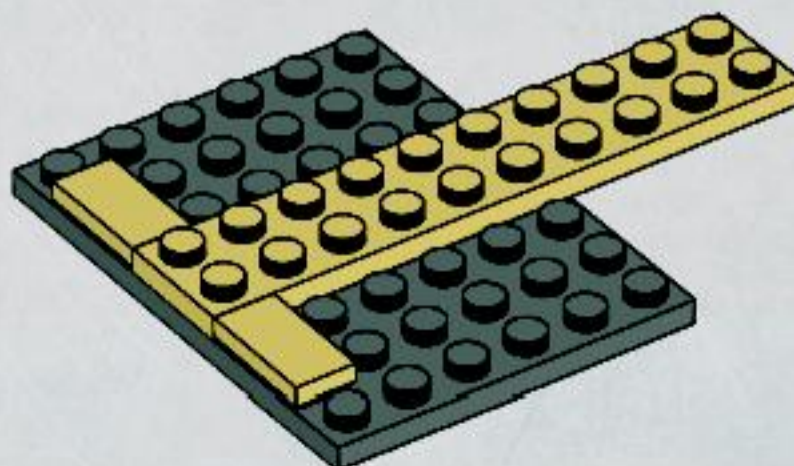



2x



2x

3

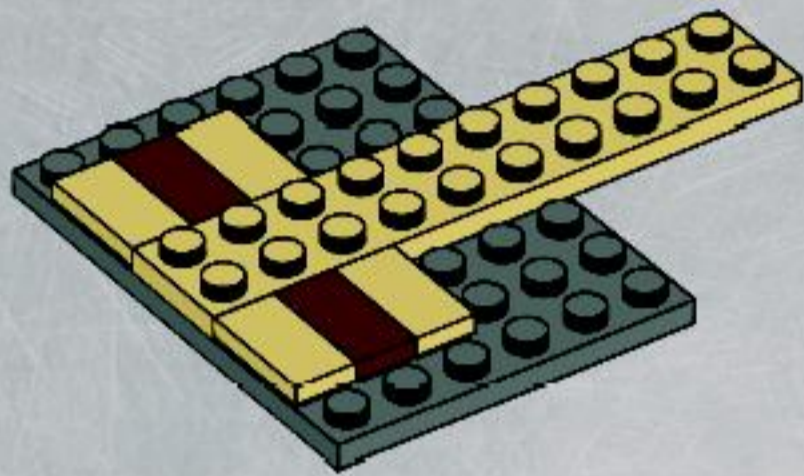

1x

5

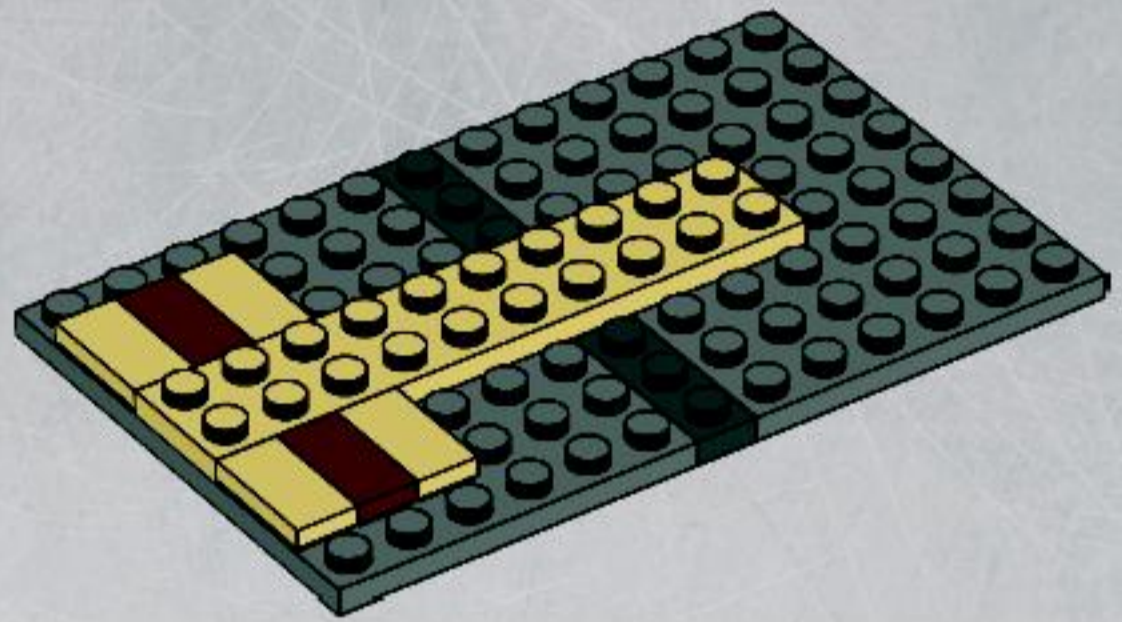

1x

4

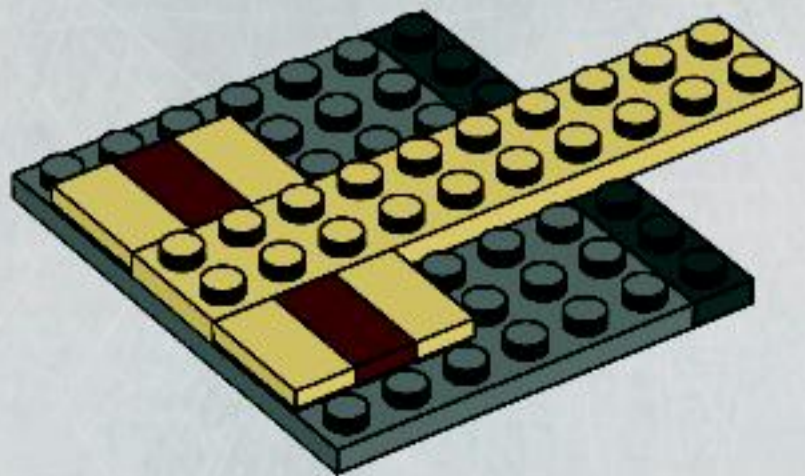

8x



6x

6

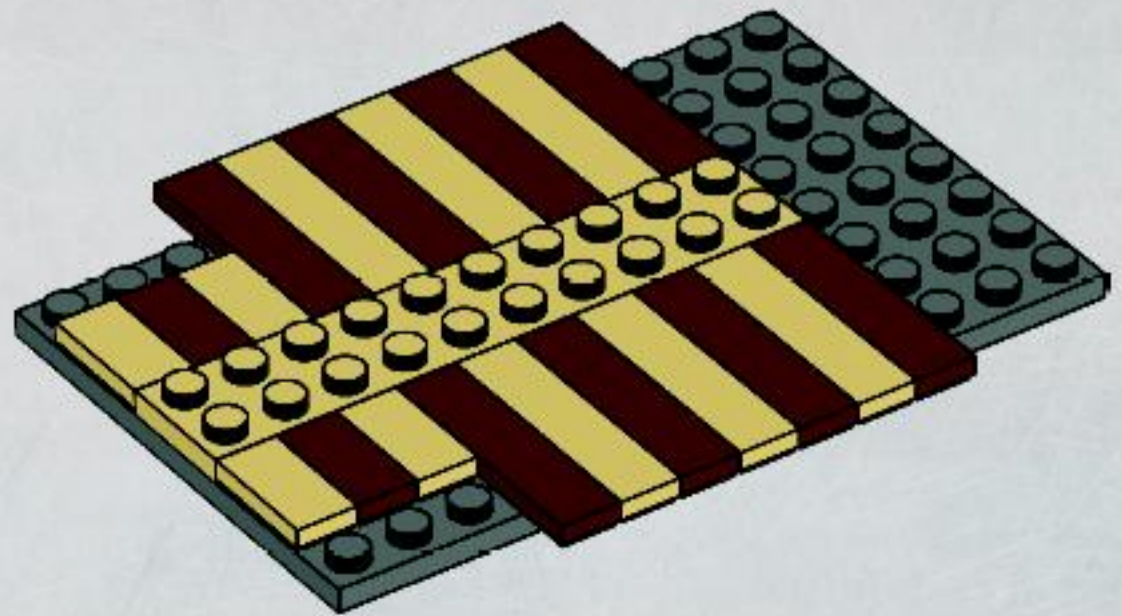

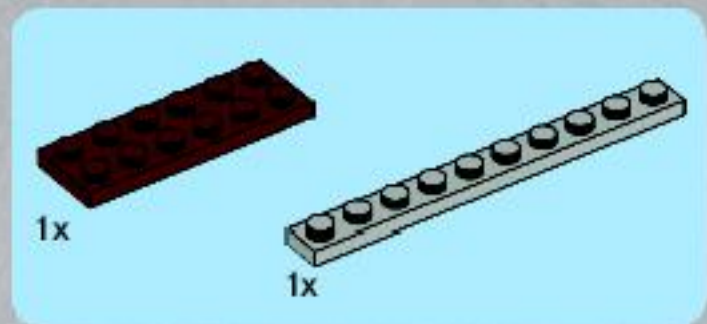

7

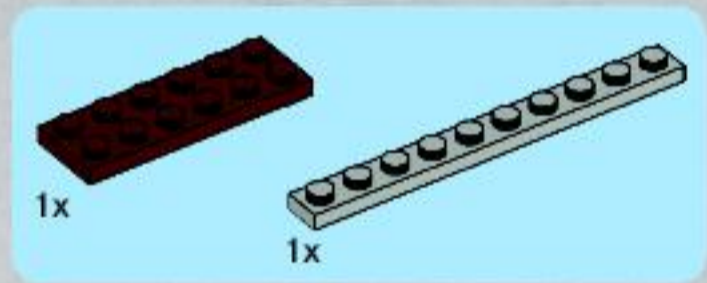
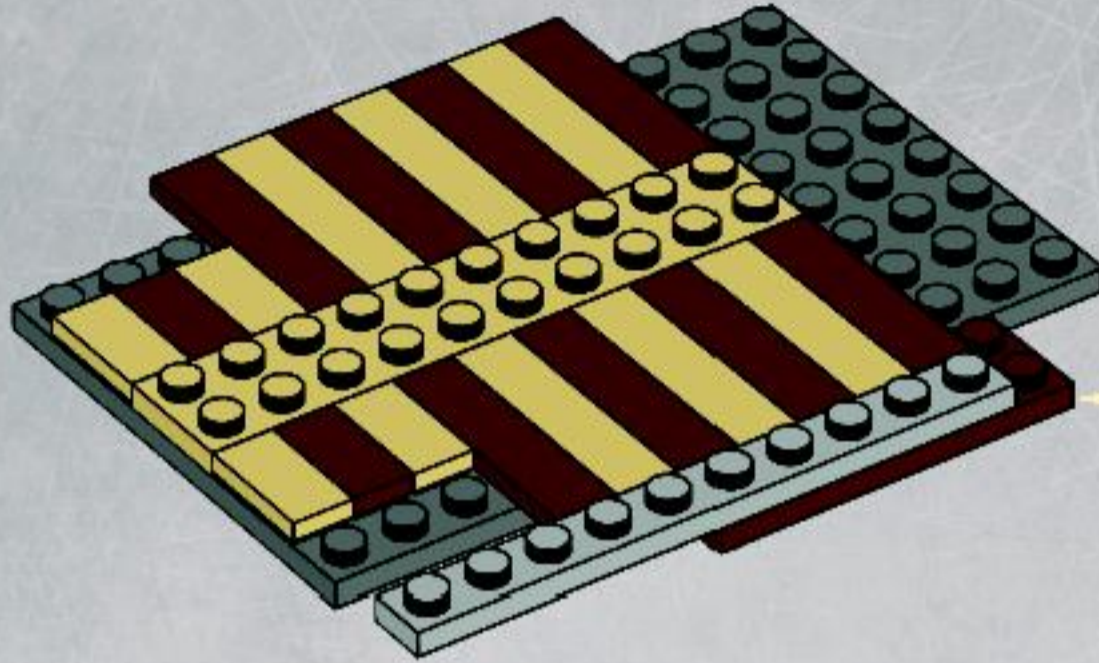
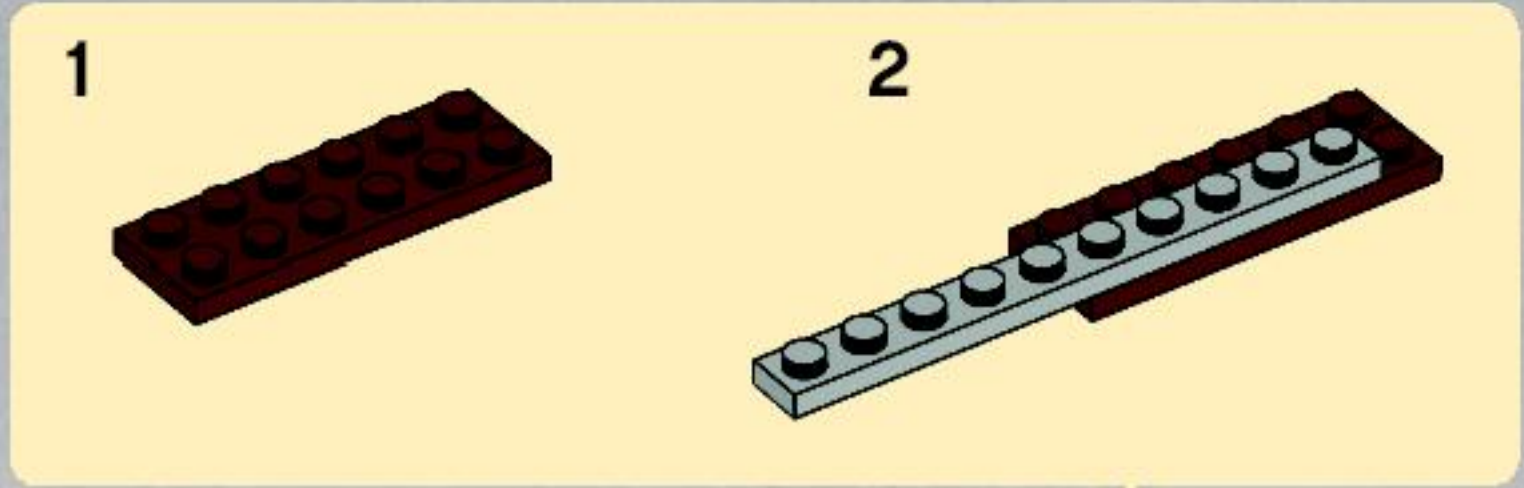

8

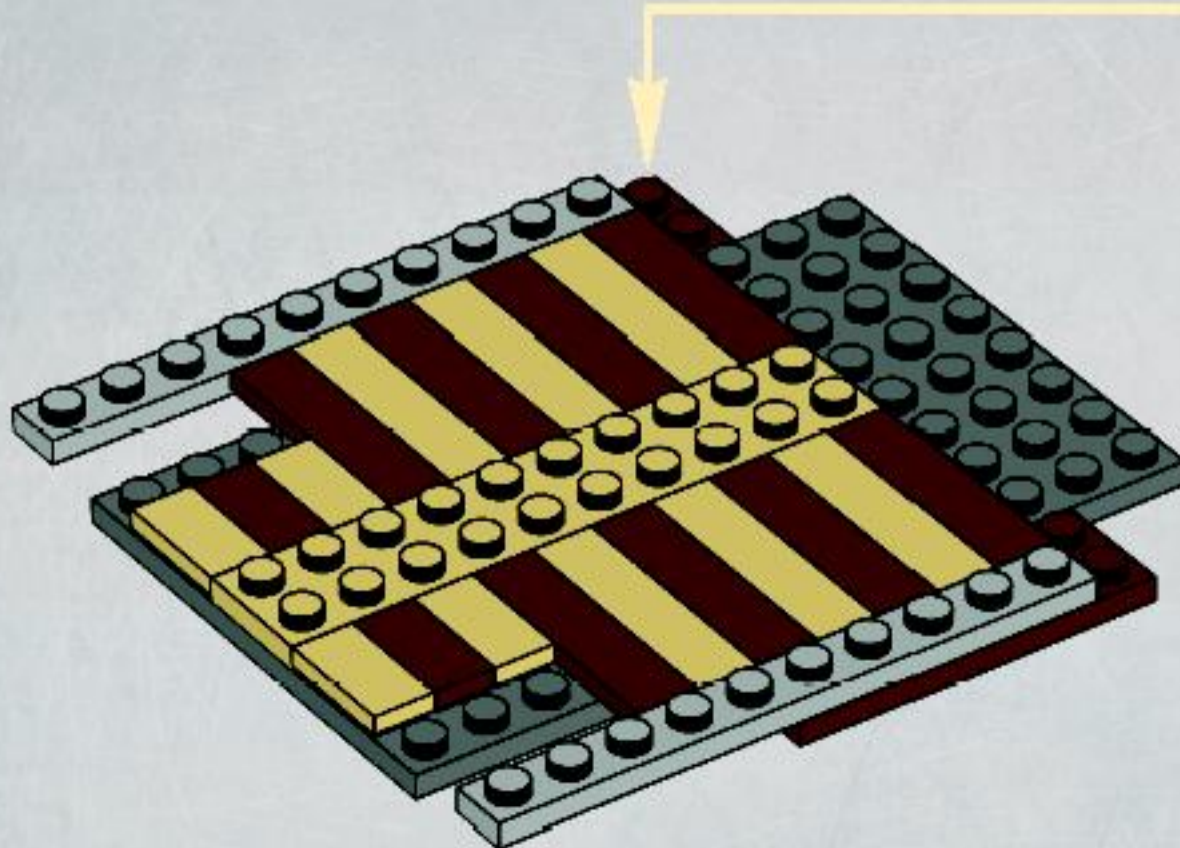
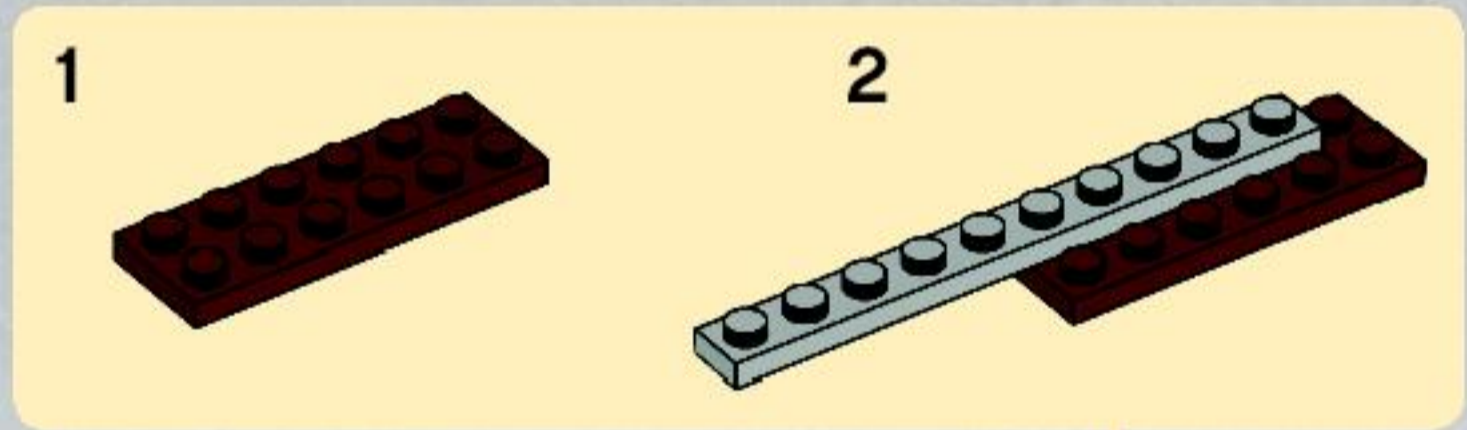

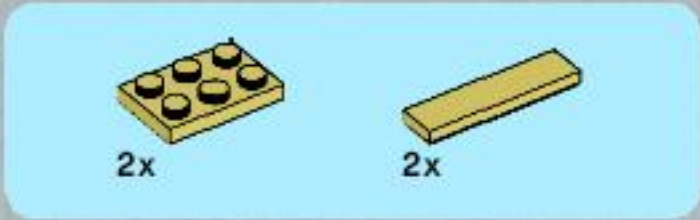

9

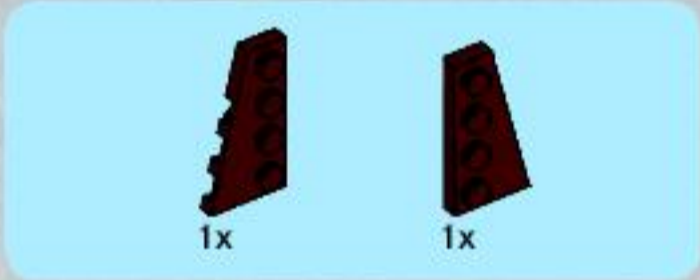
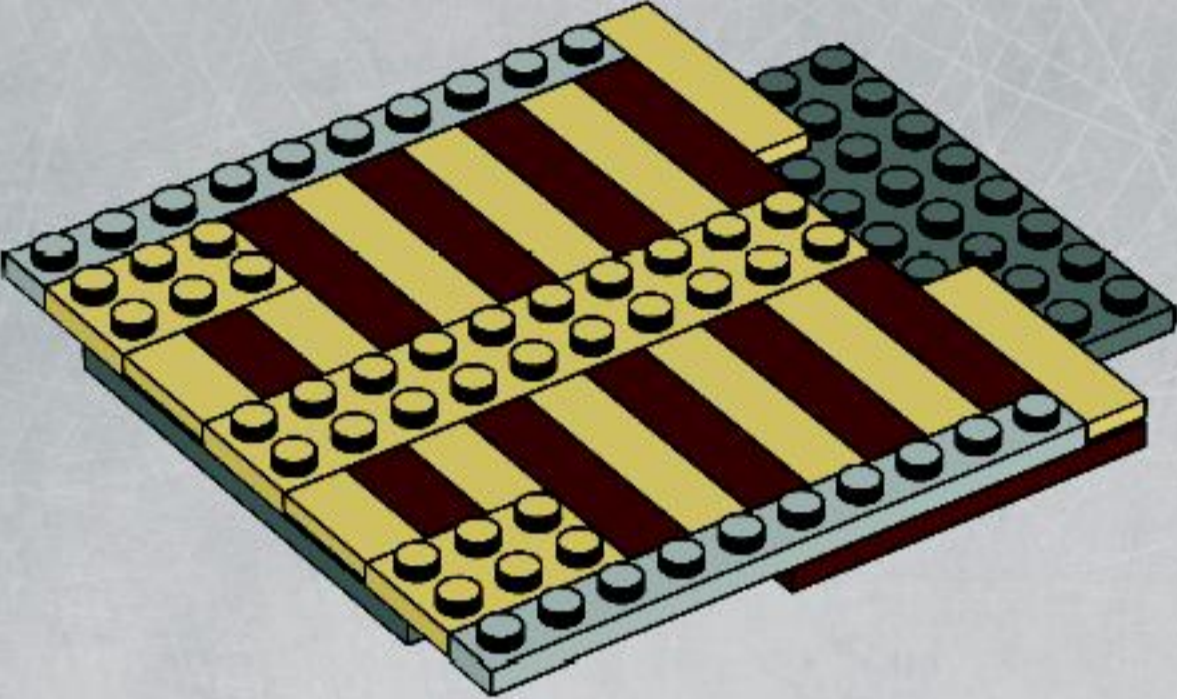

10

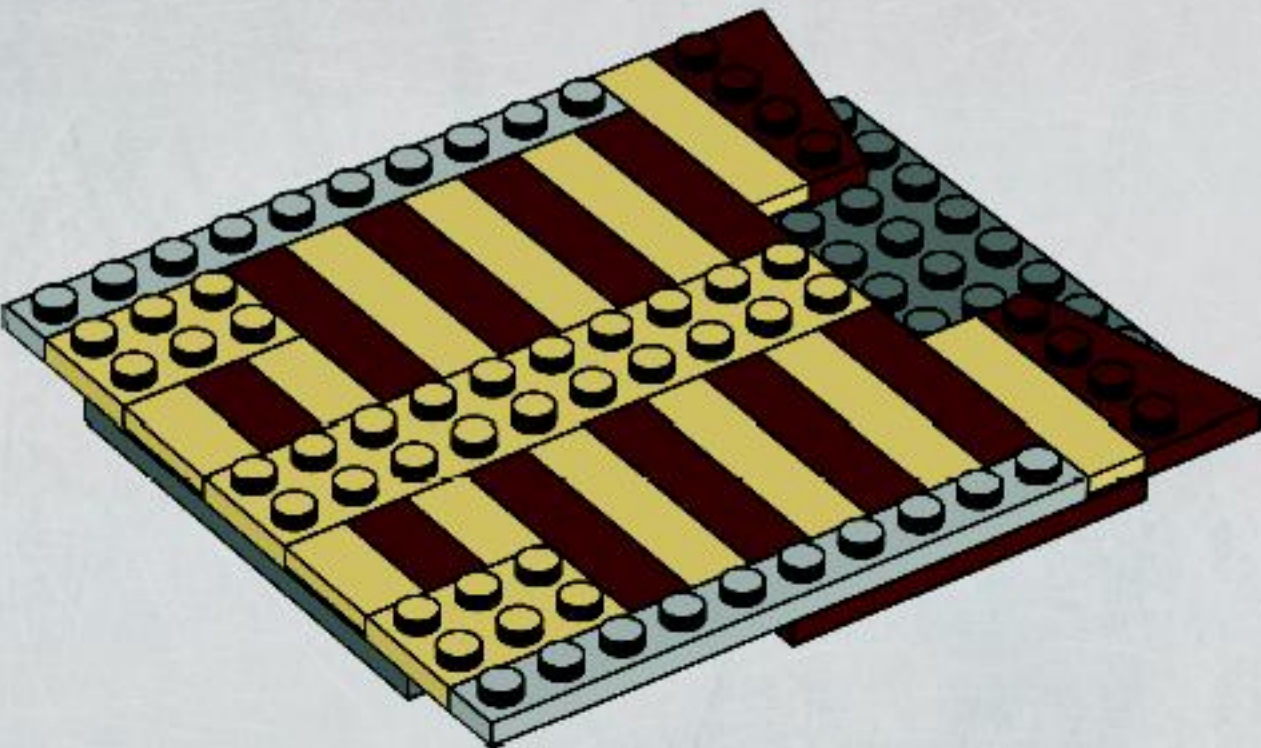



6x

11

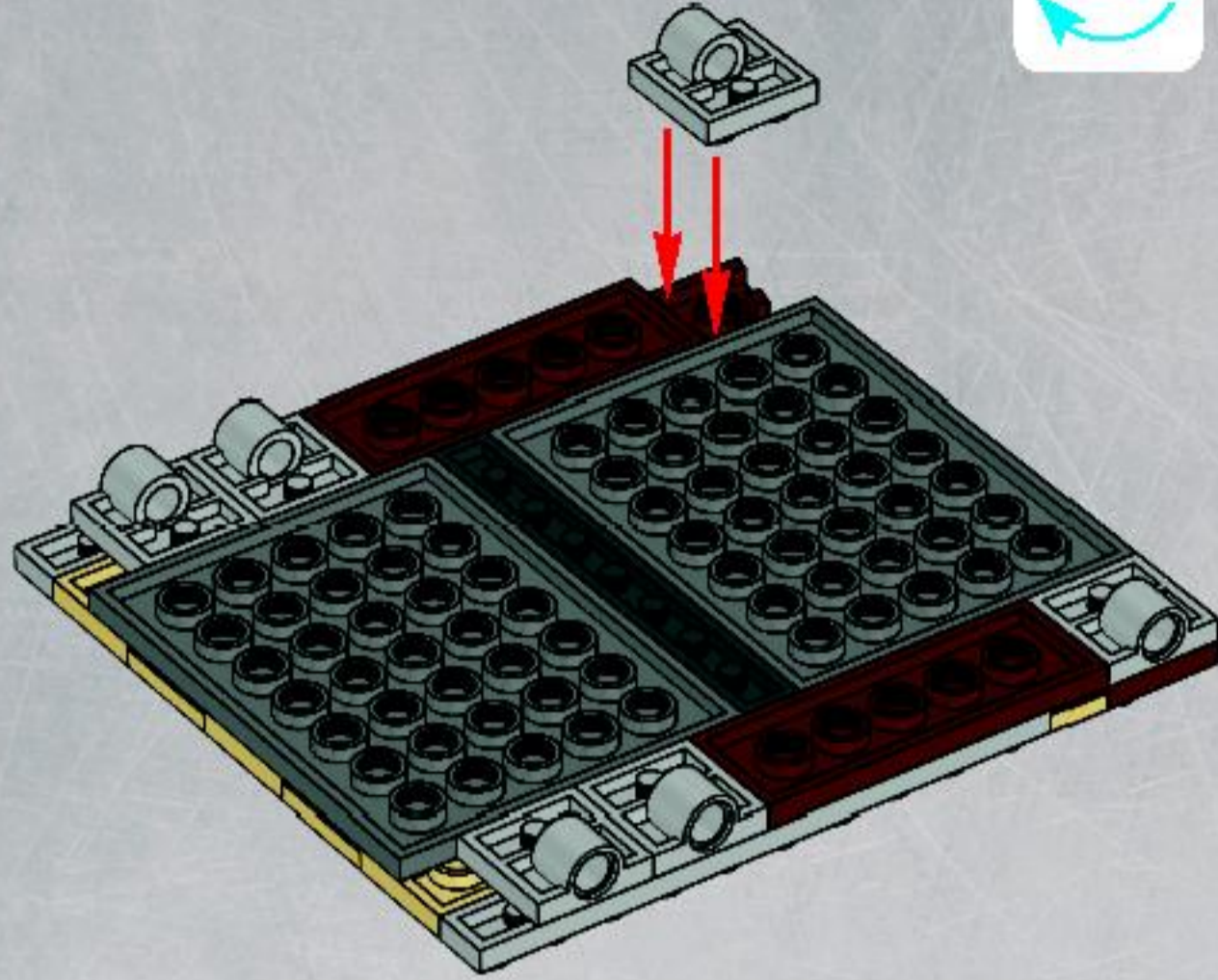

2x

12

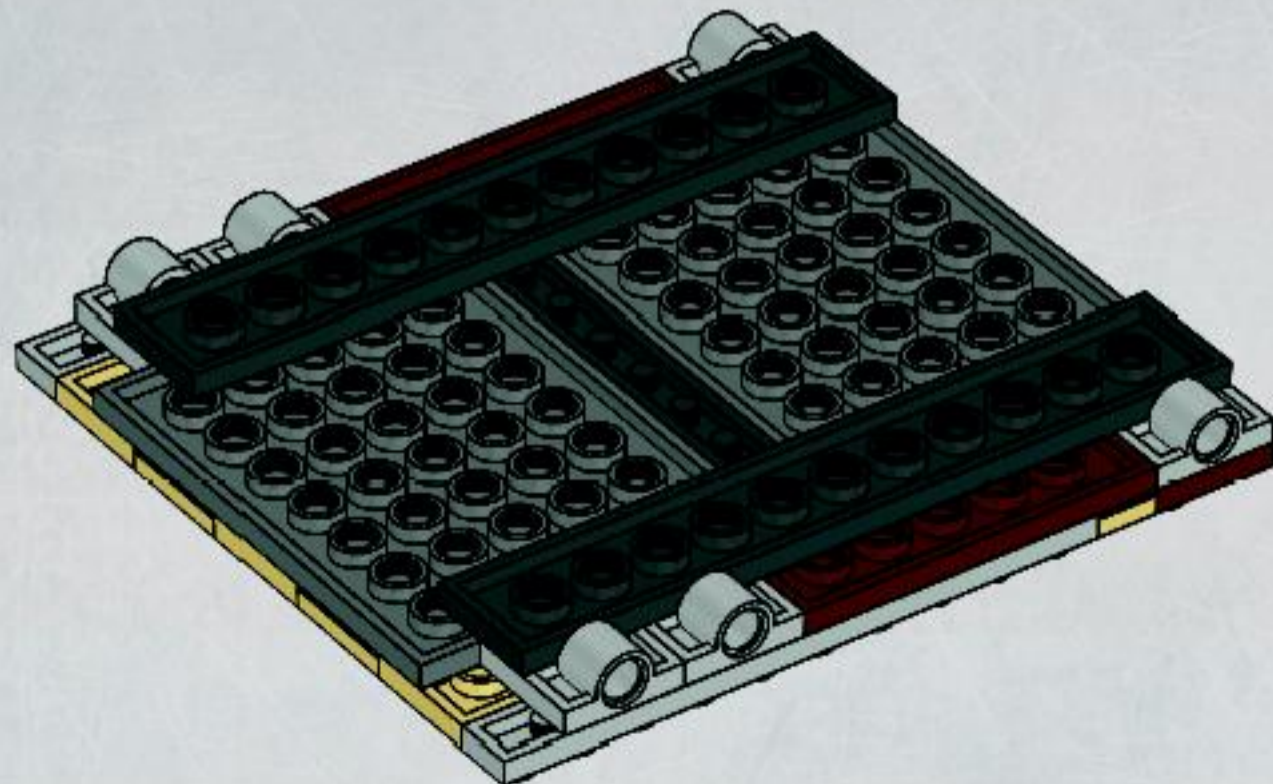

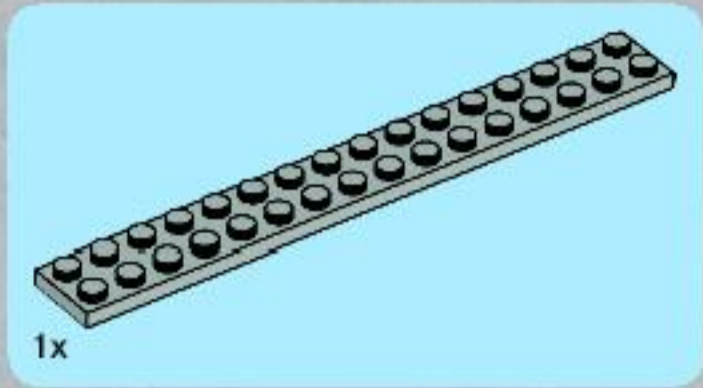
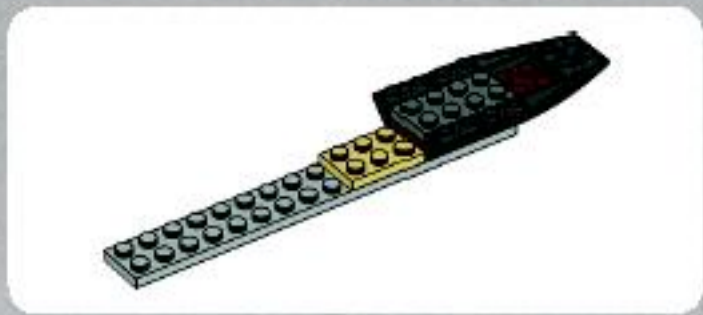

1

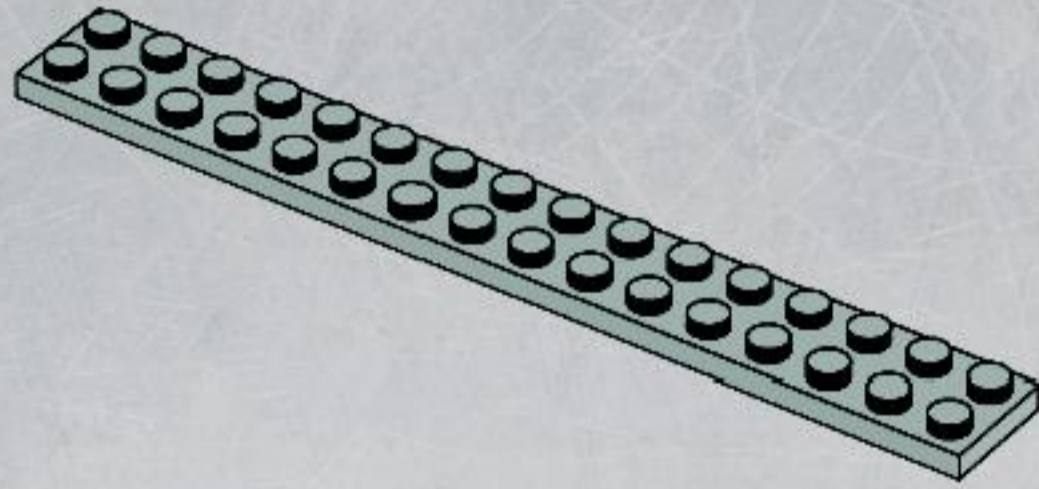

2

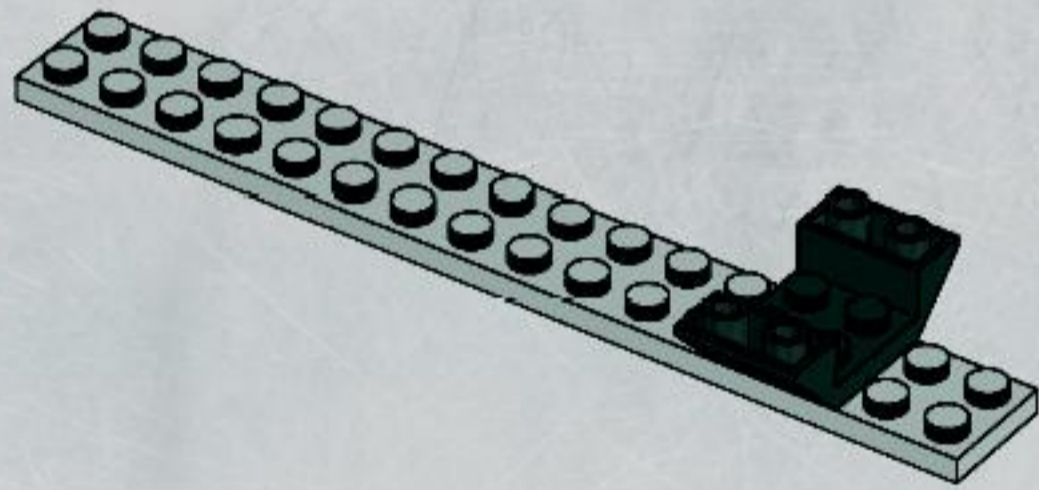

3

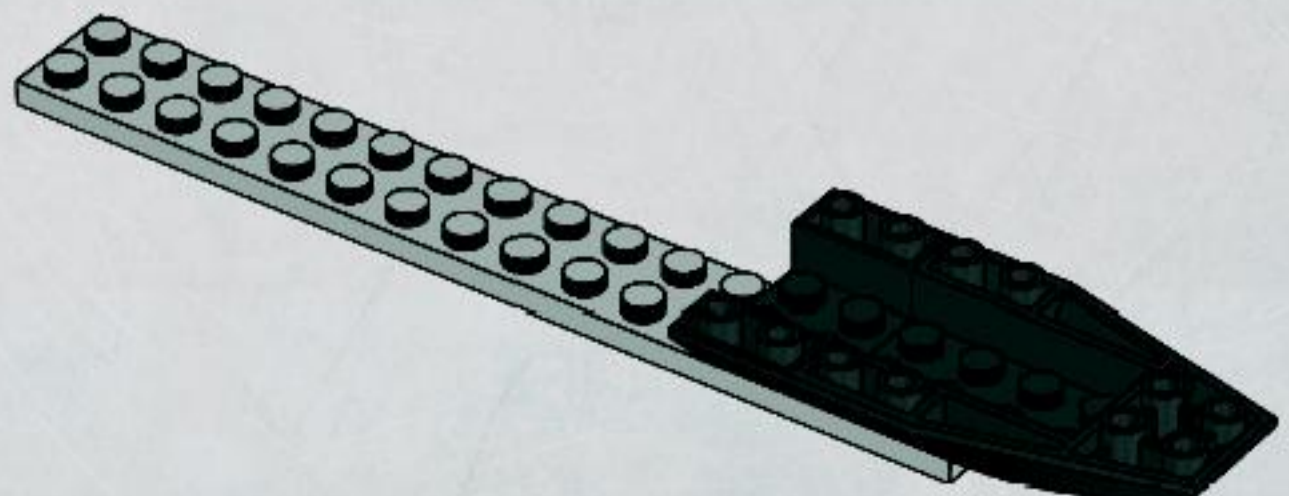

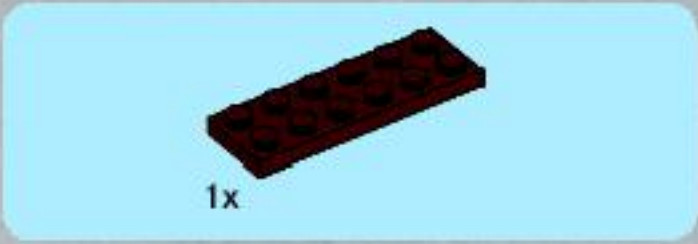

4

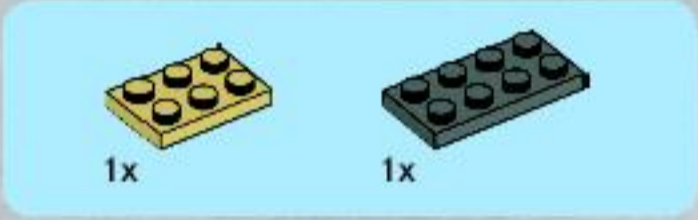
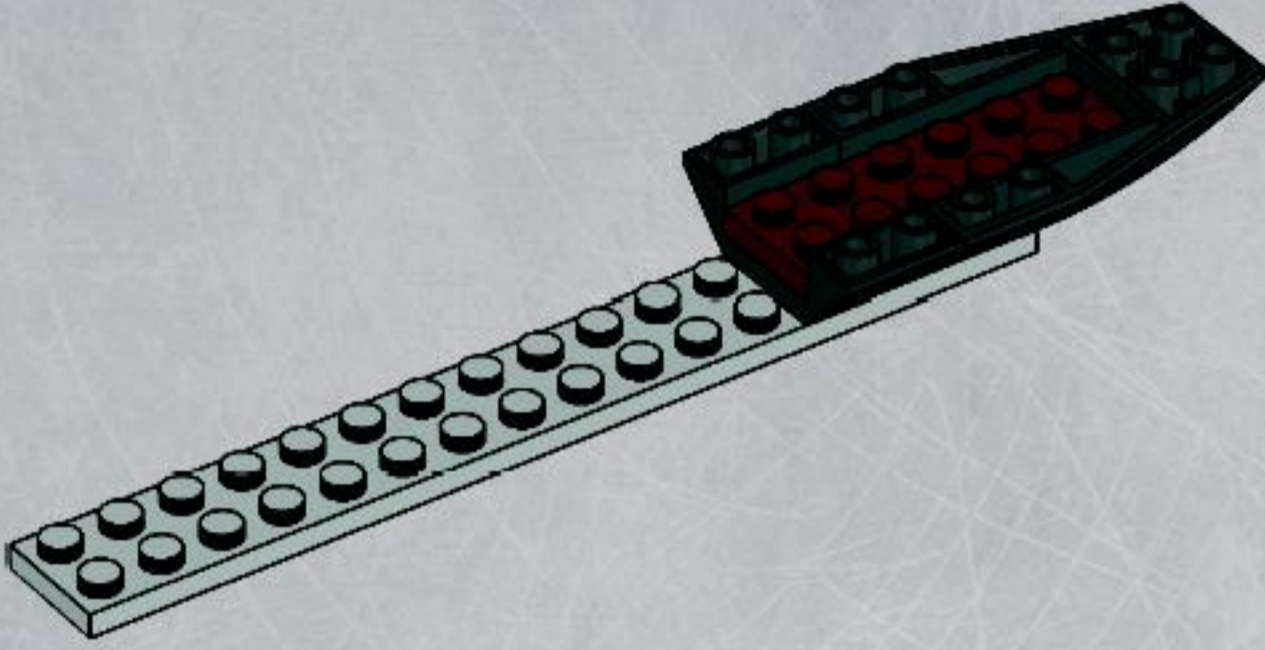

5

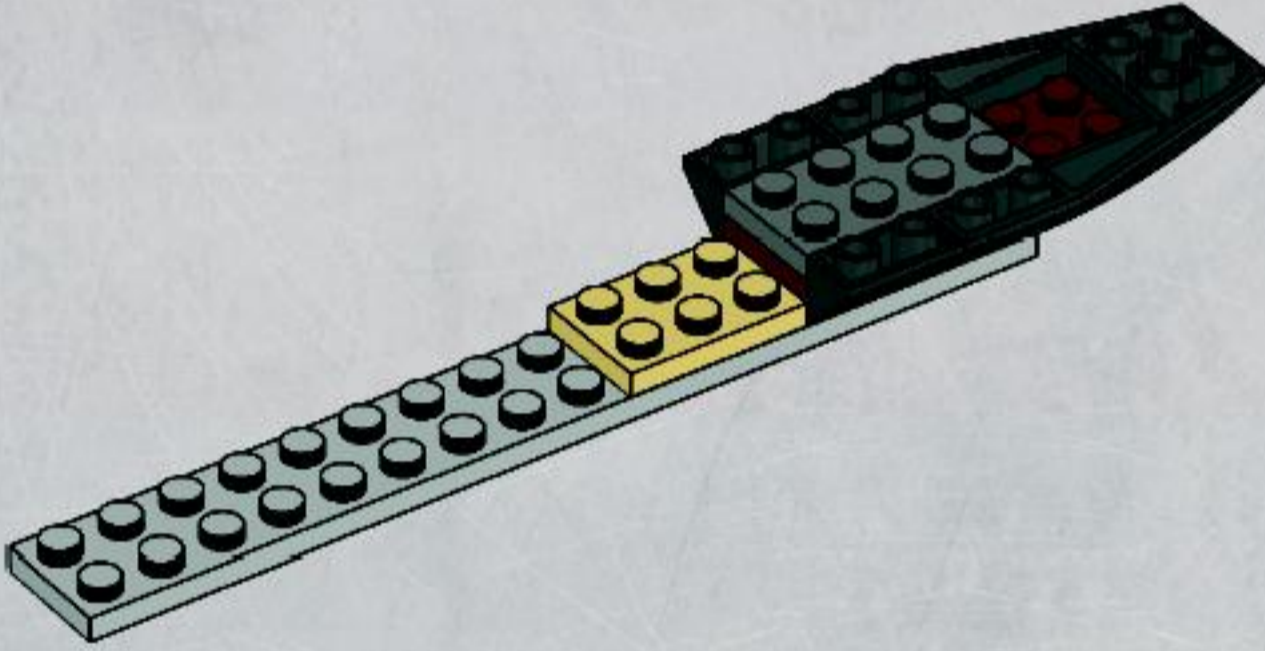

13

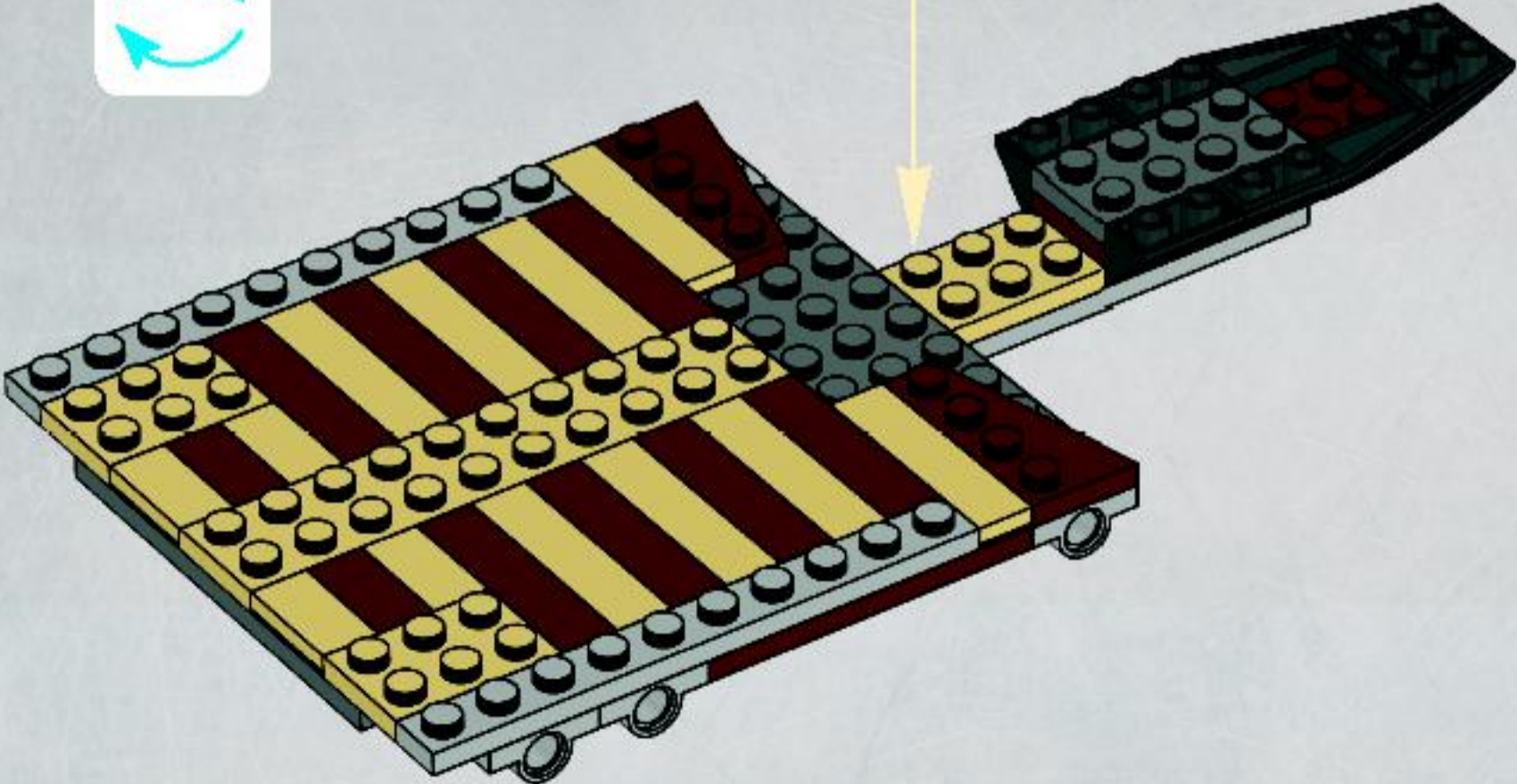

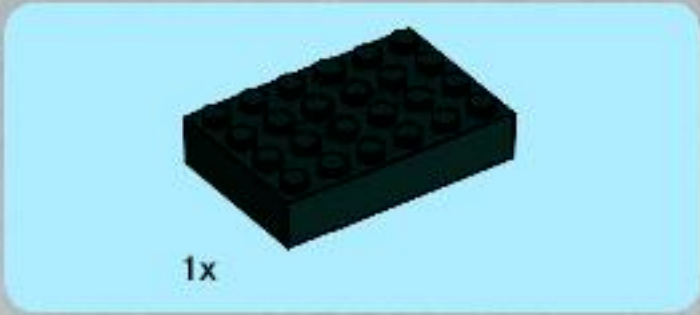

14

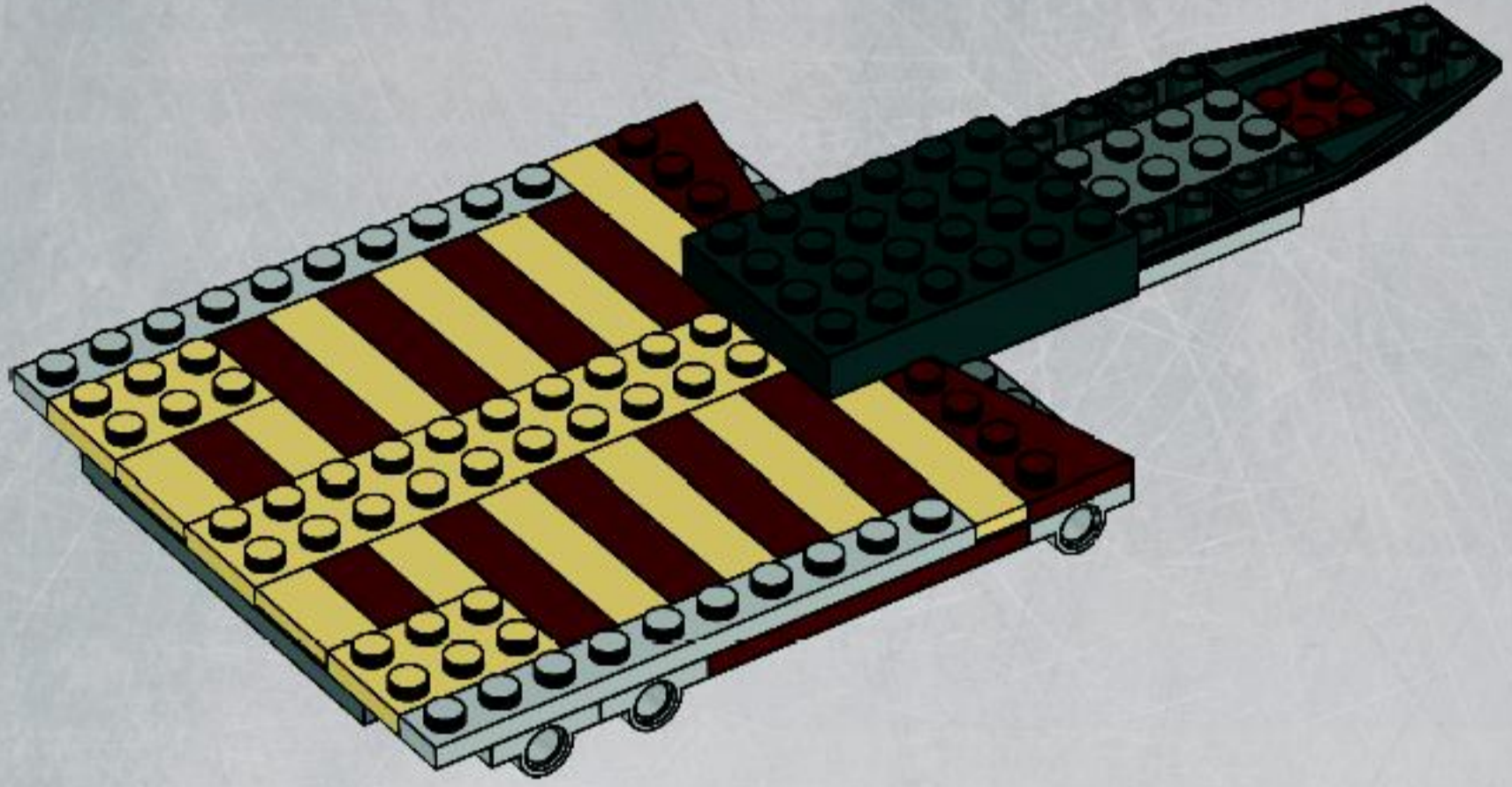

15

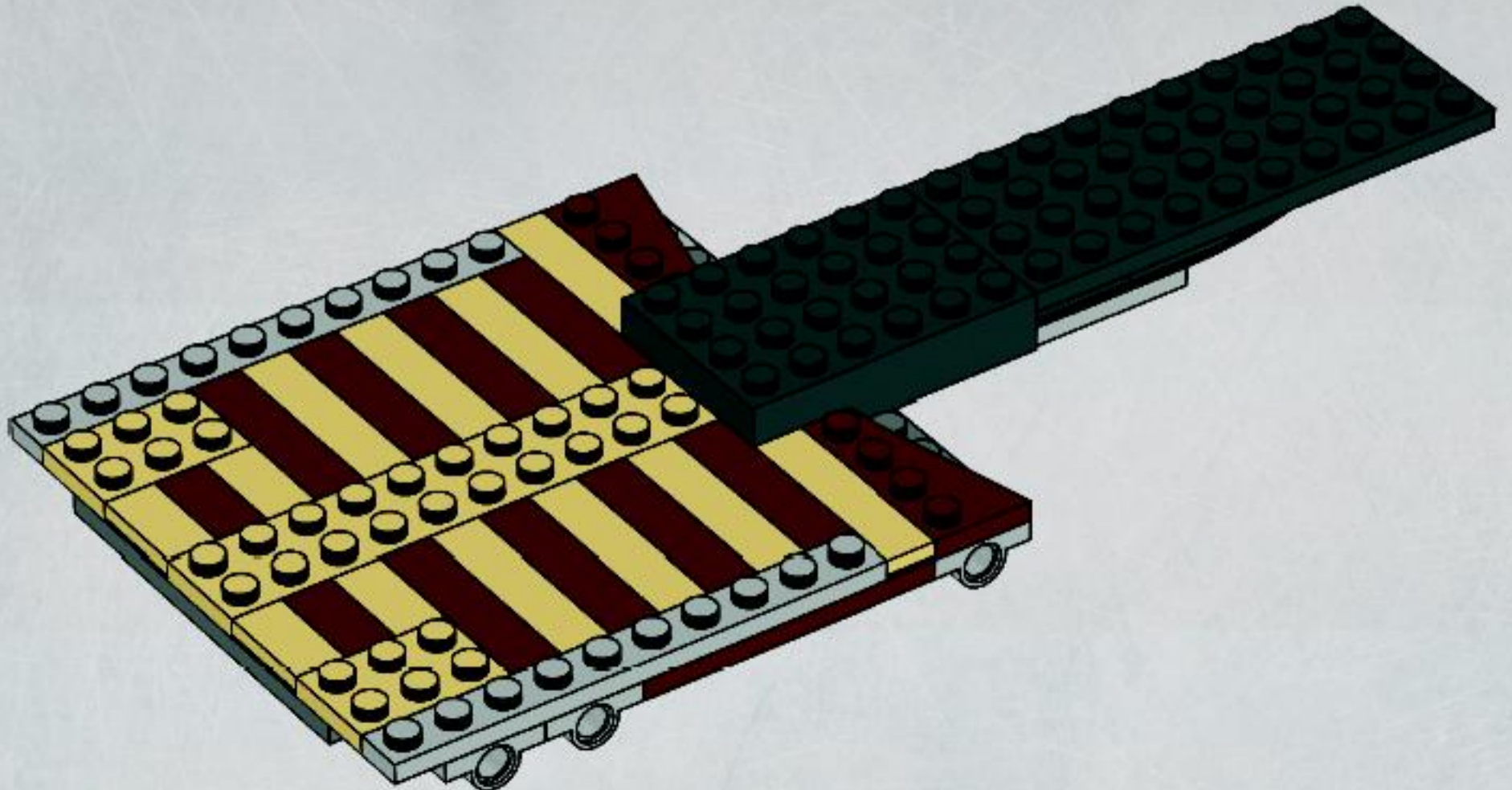

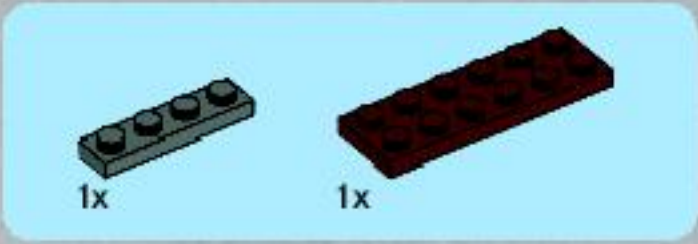

16

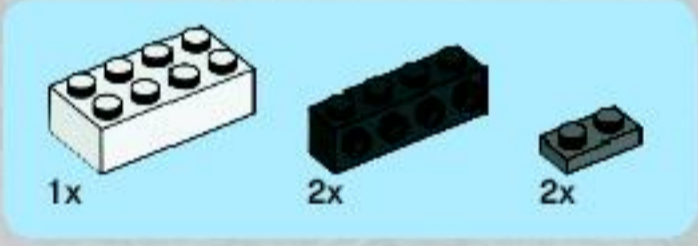
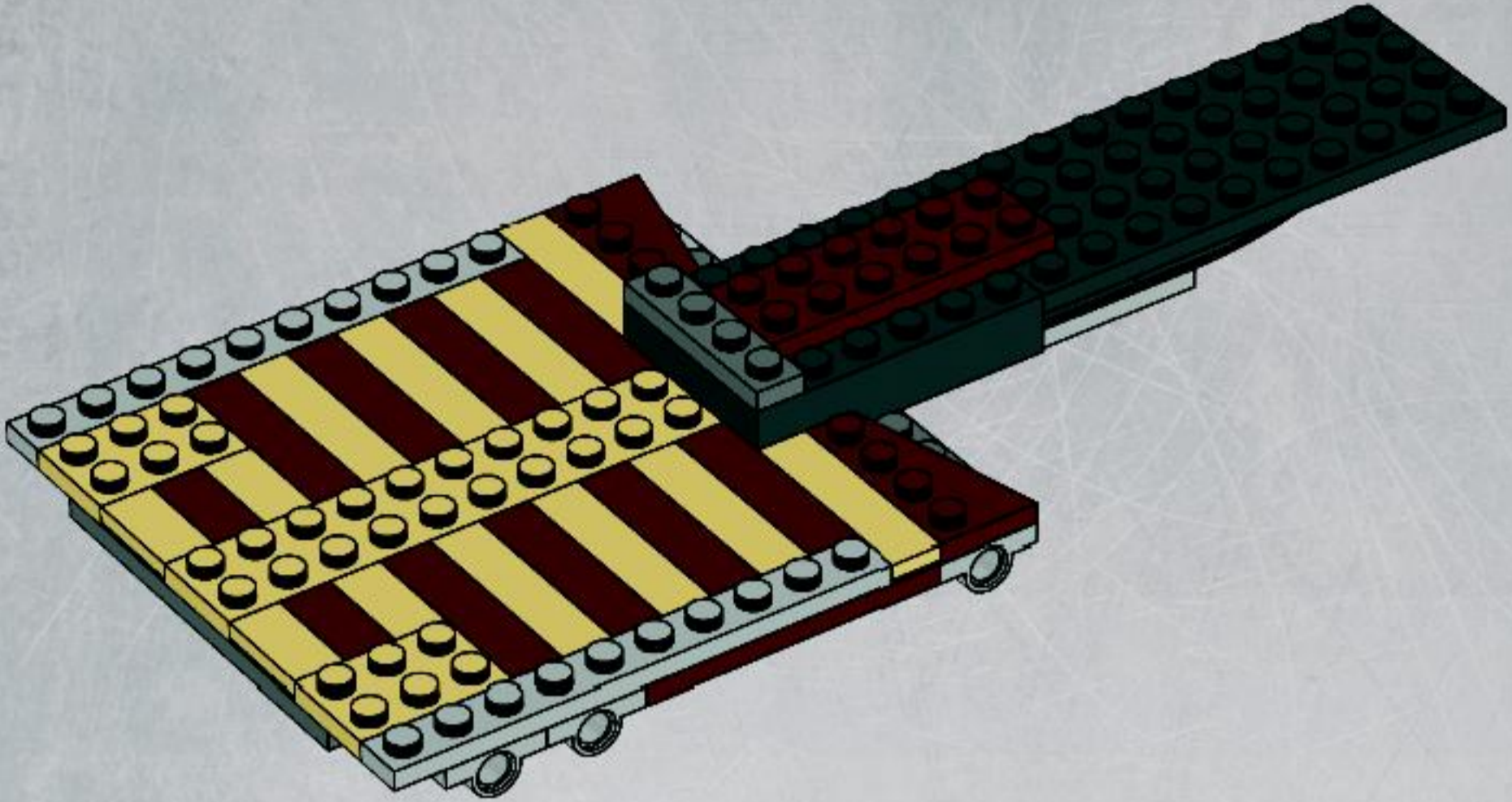

17

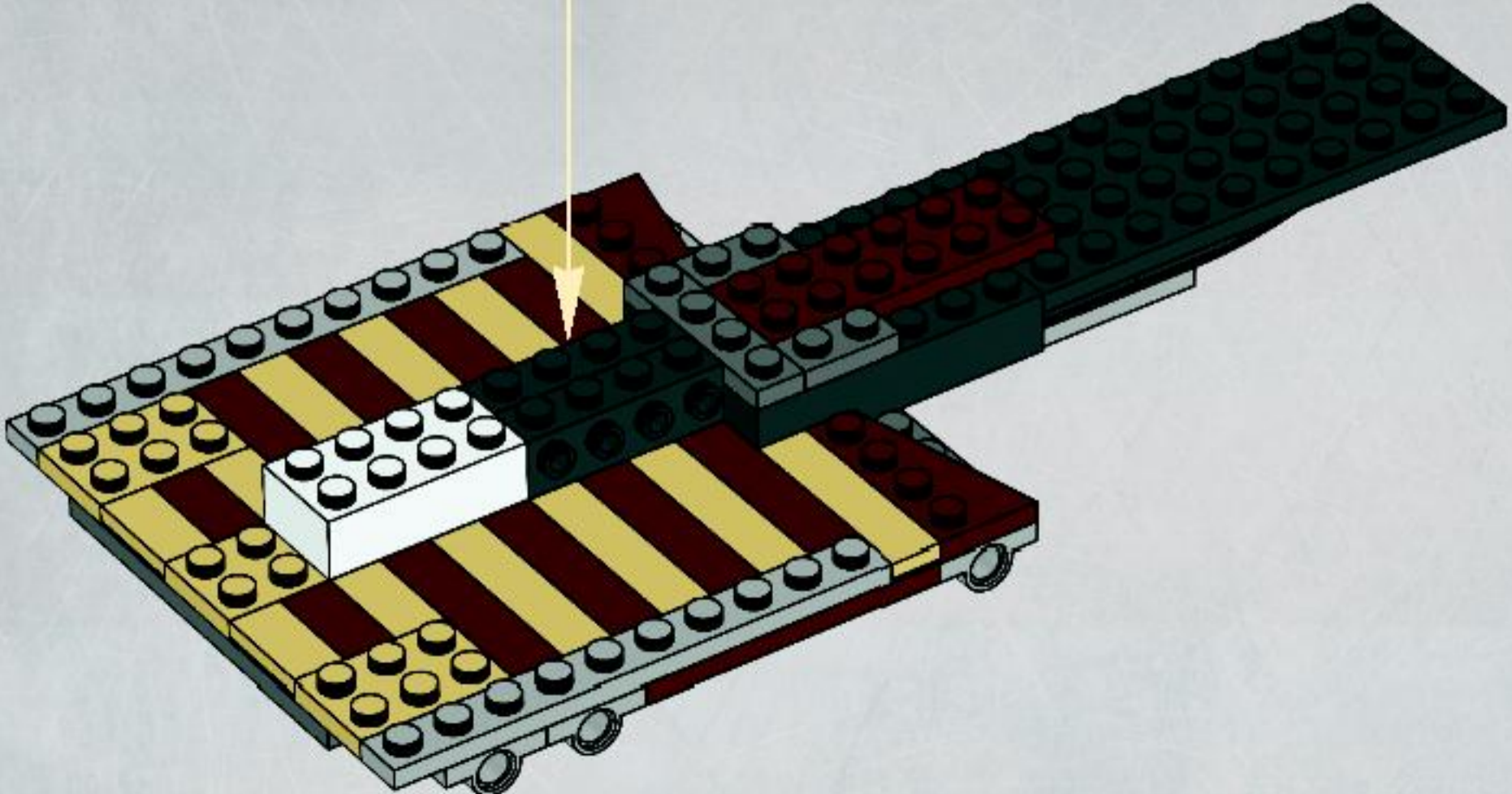



18

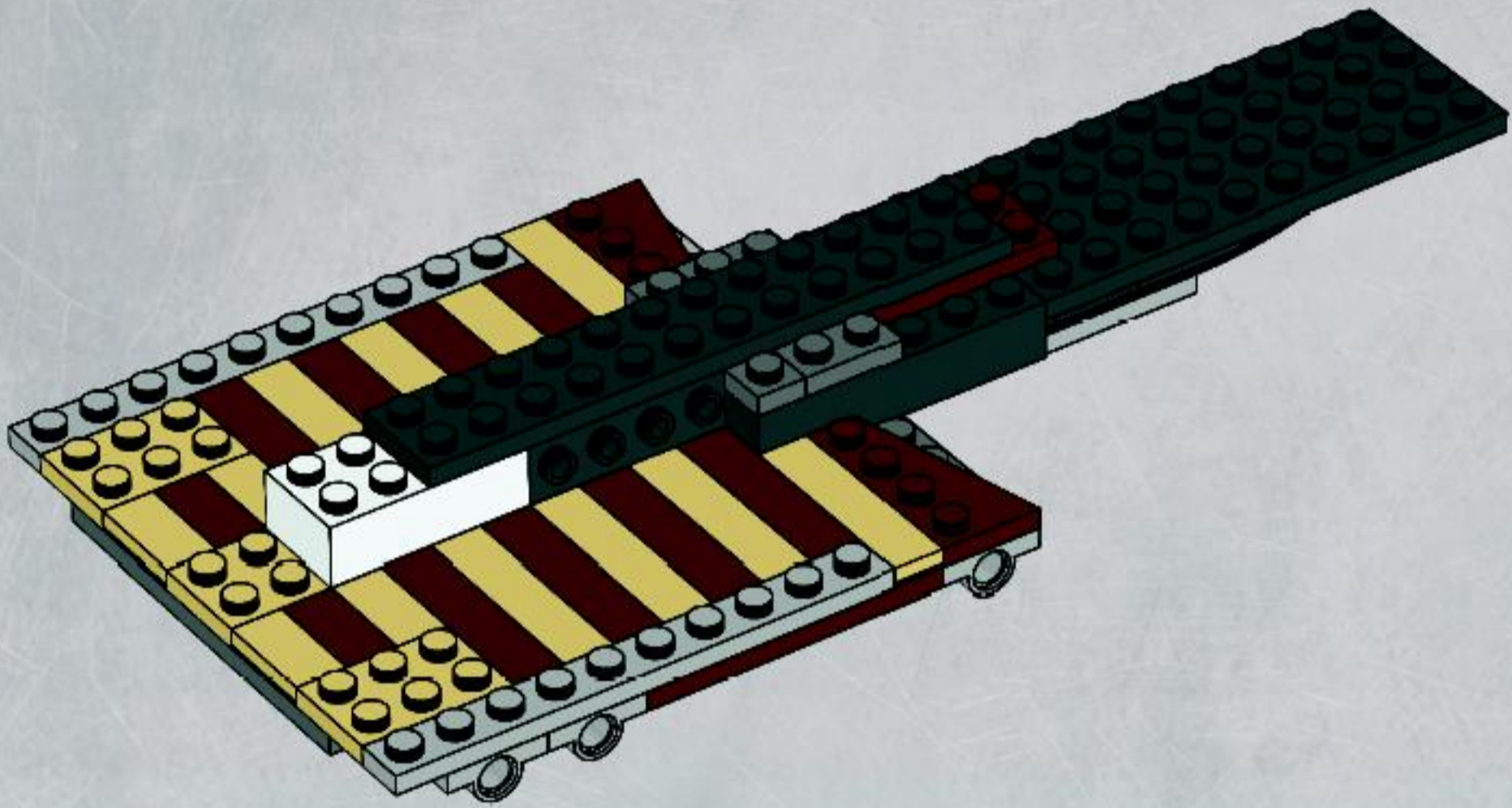

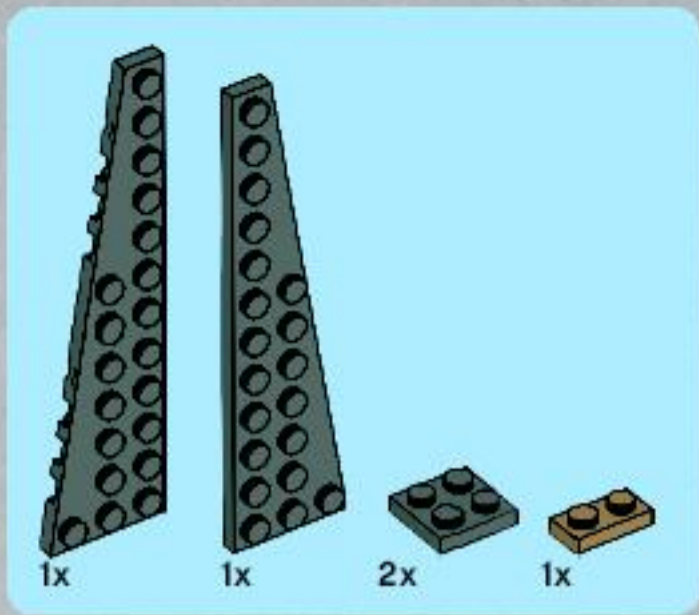

19

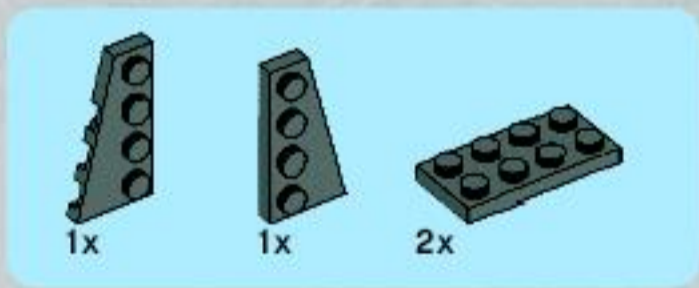
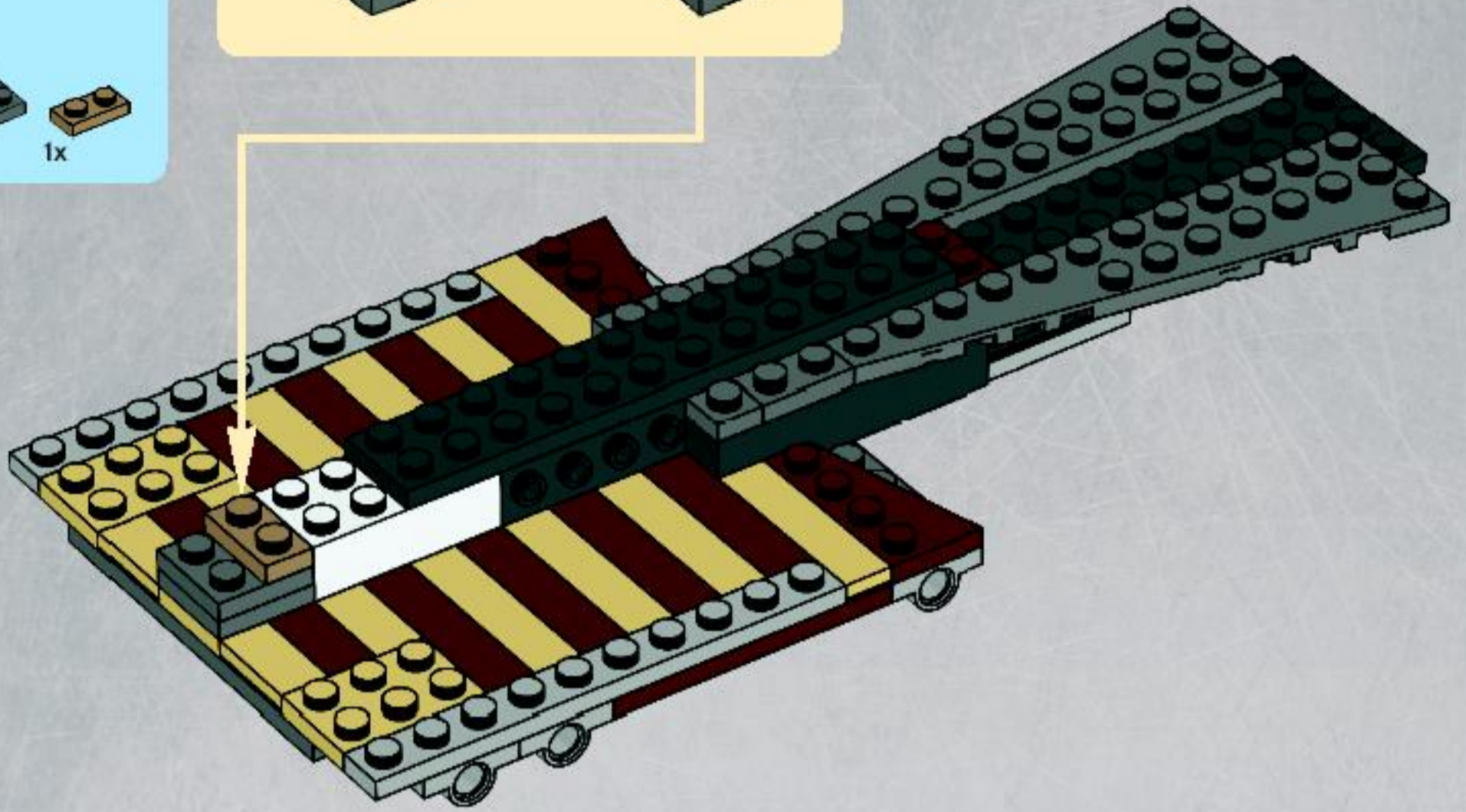
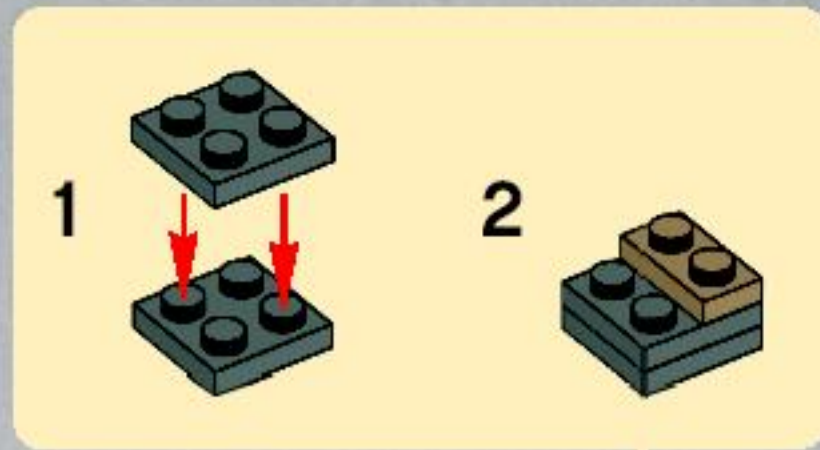

20

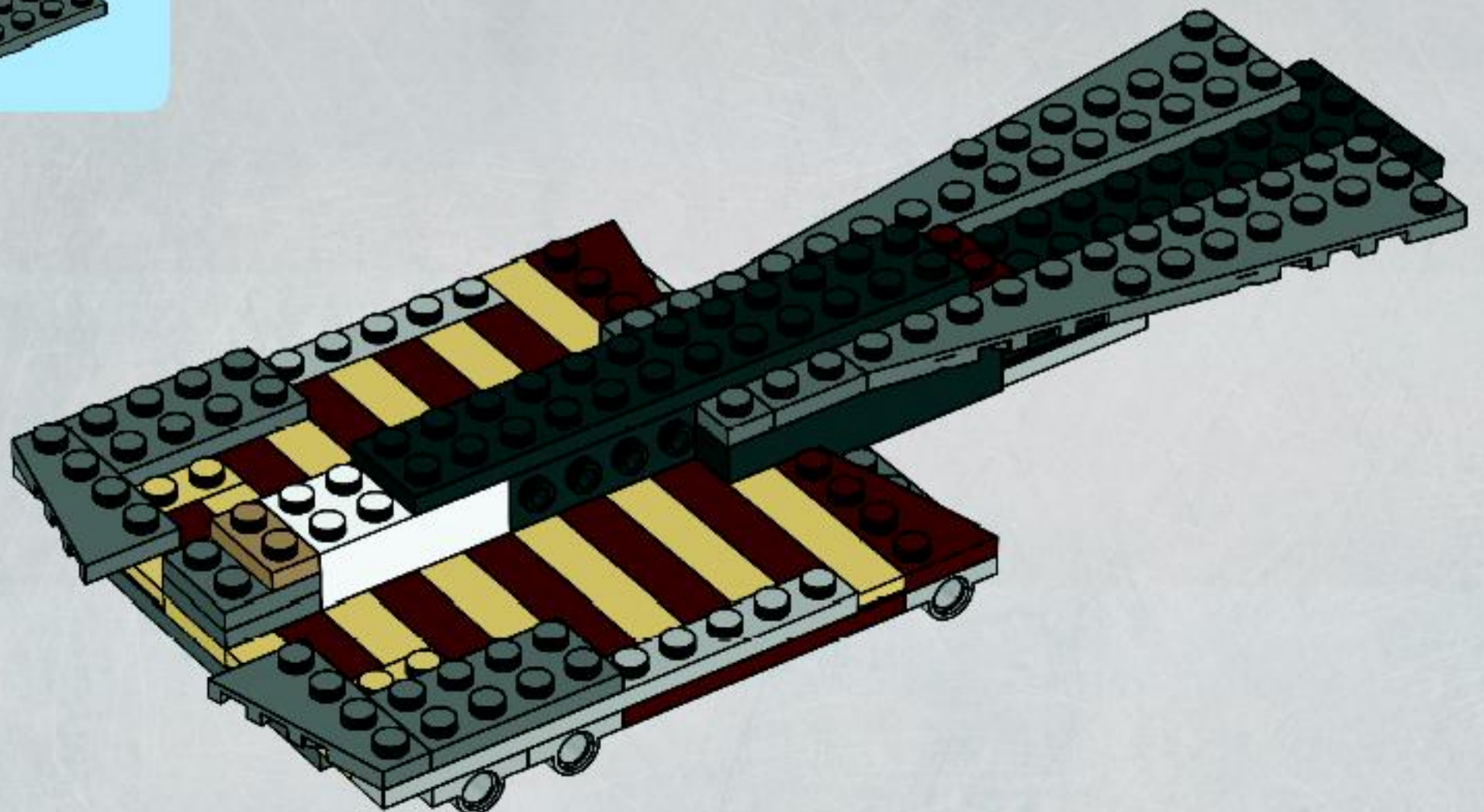

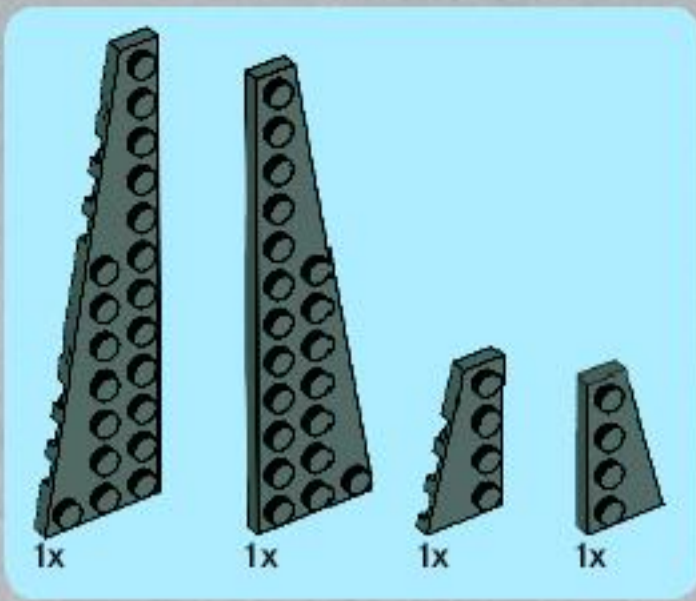

21

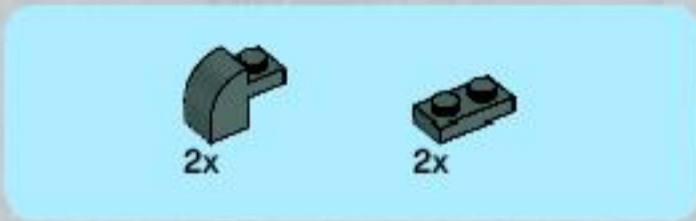
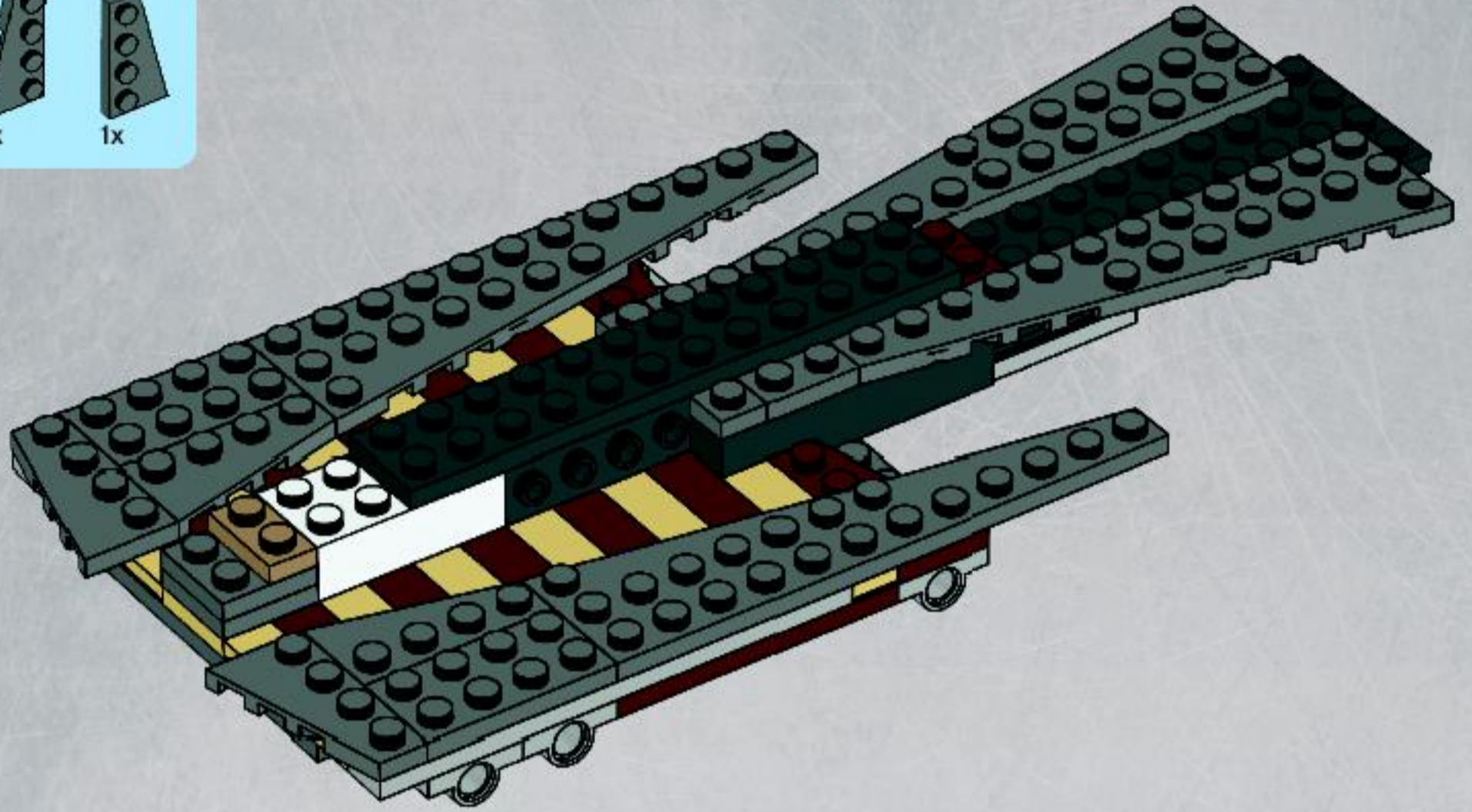

22

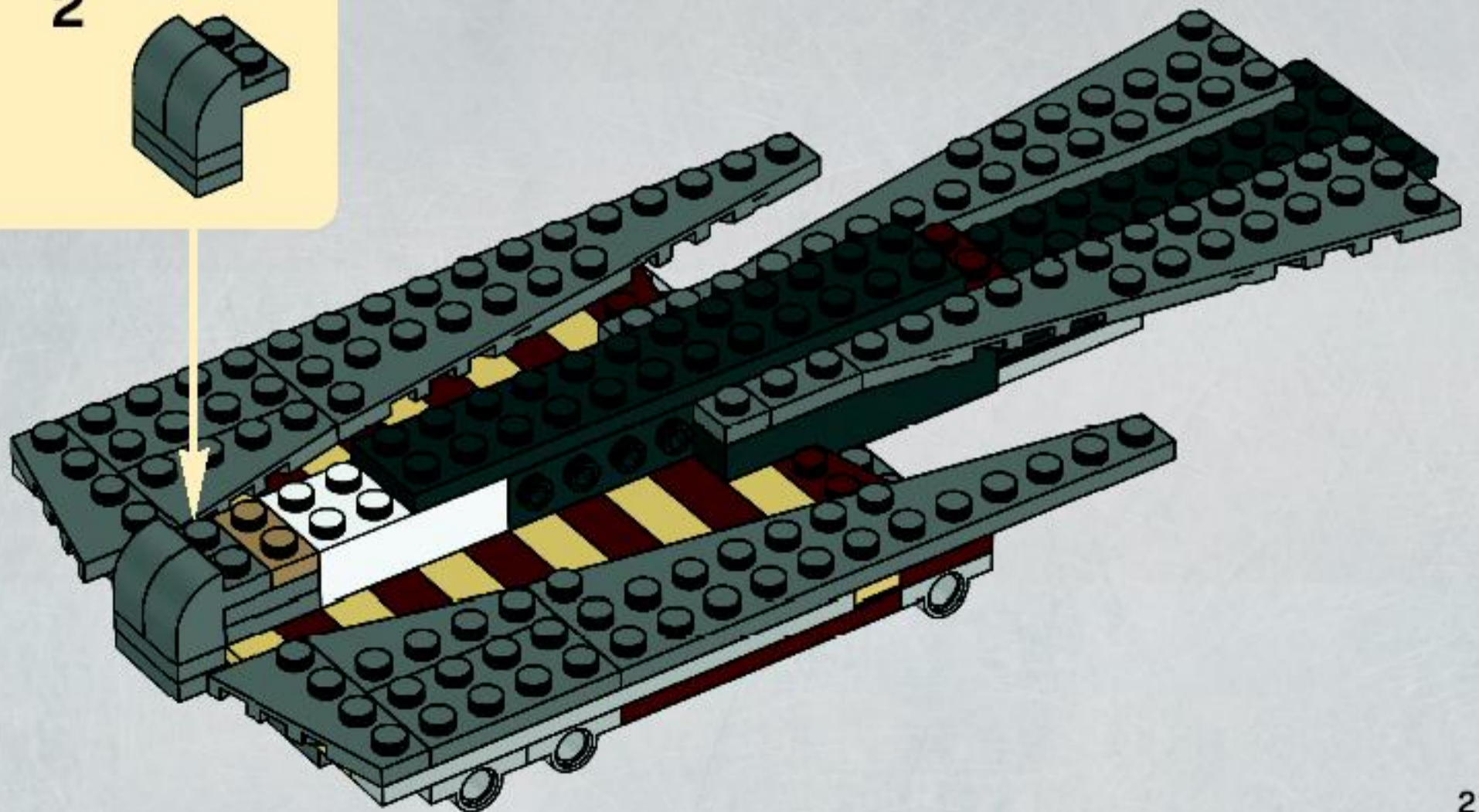
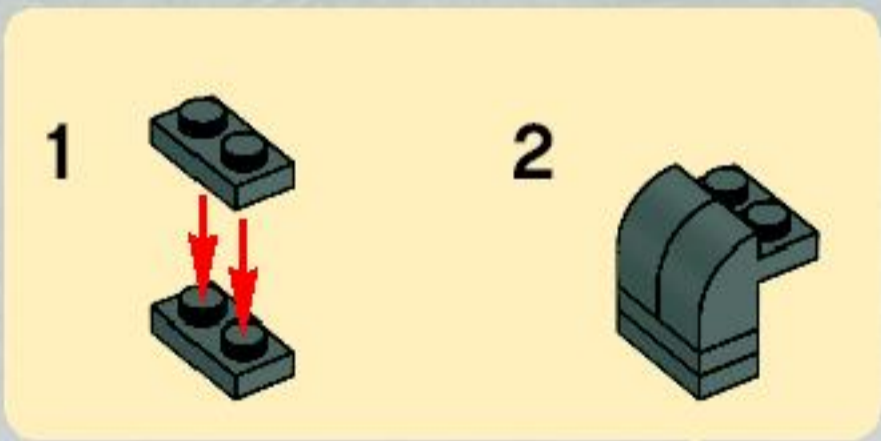

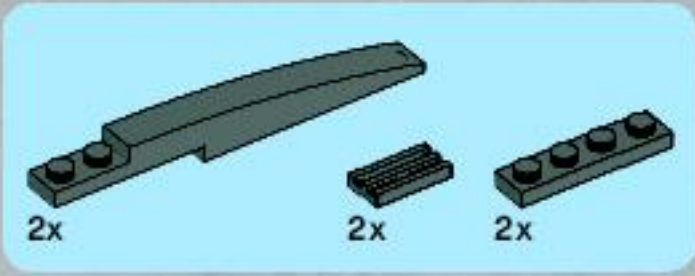

23

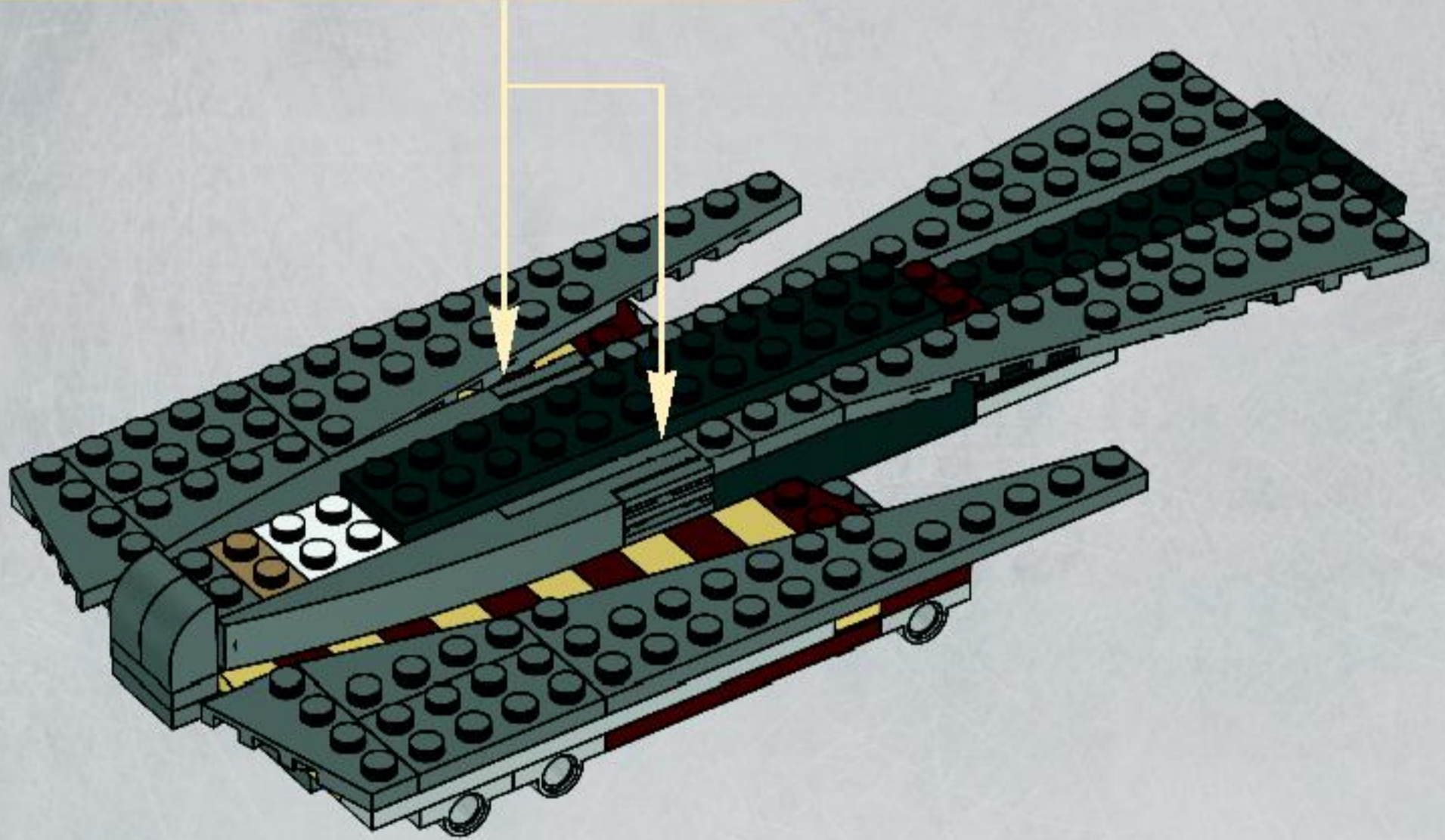
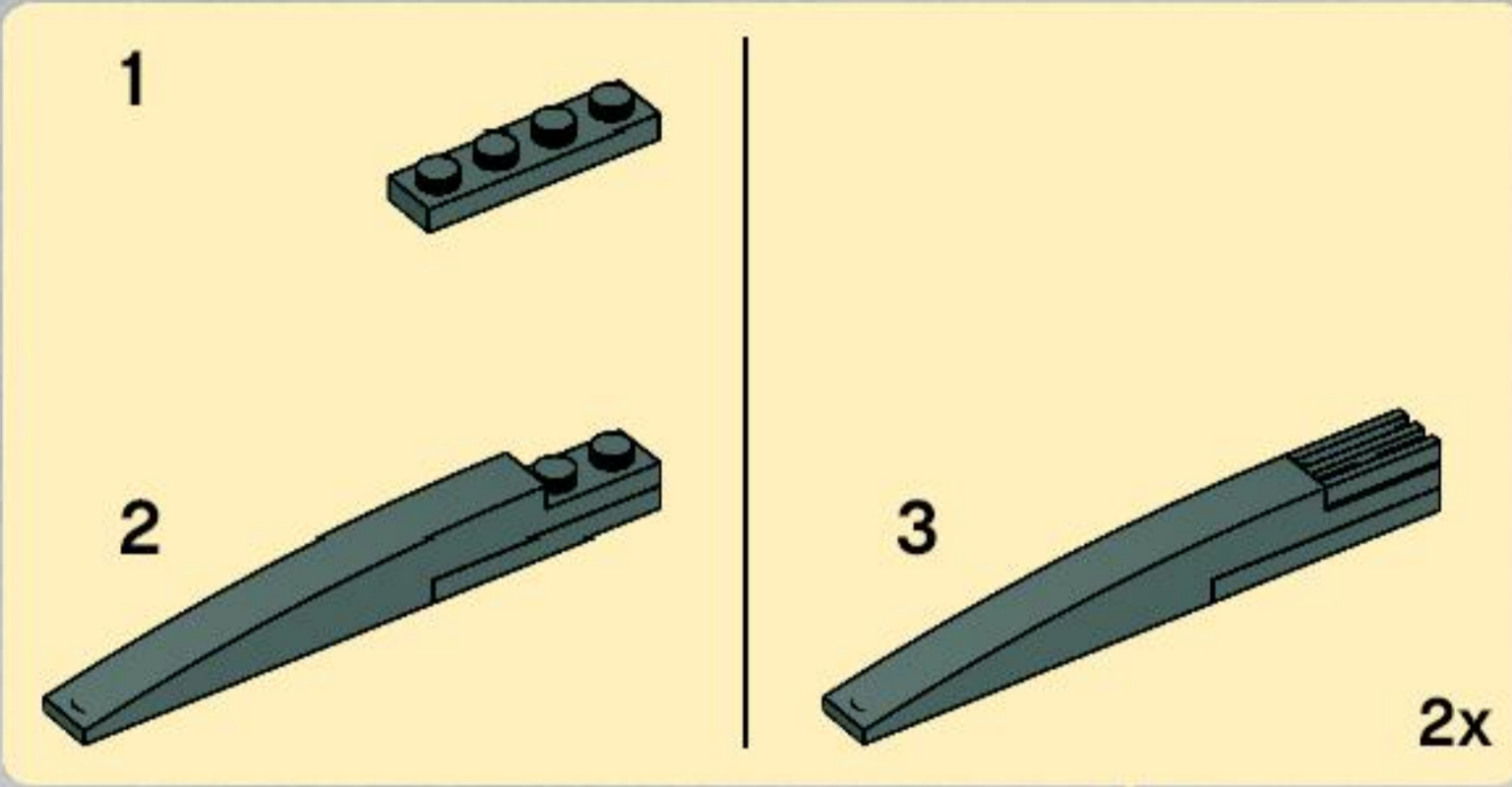

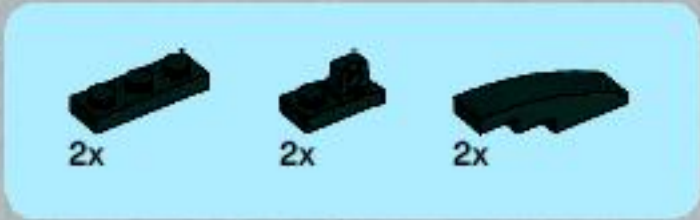

24

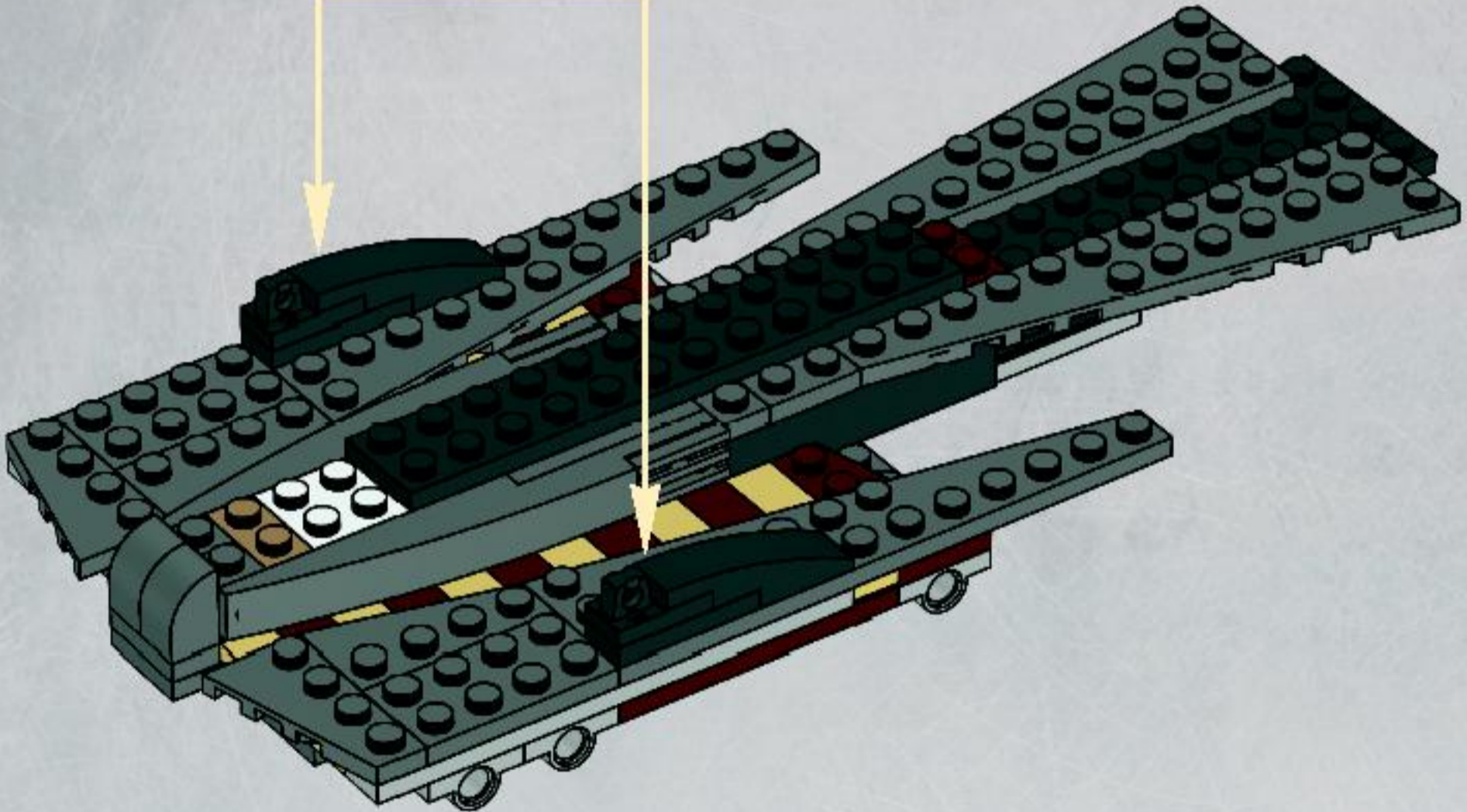
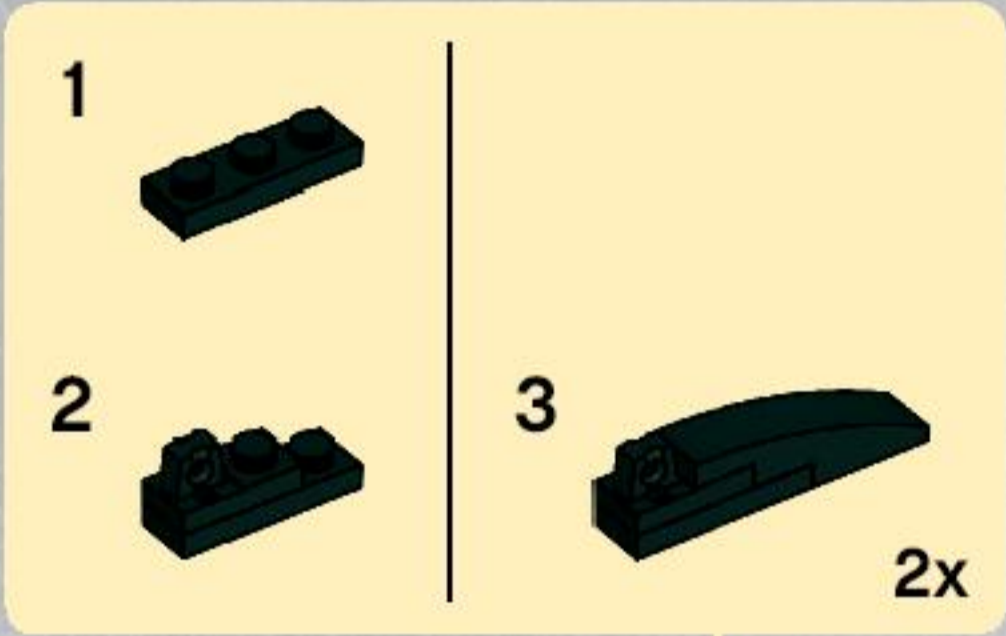



2x

25

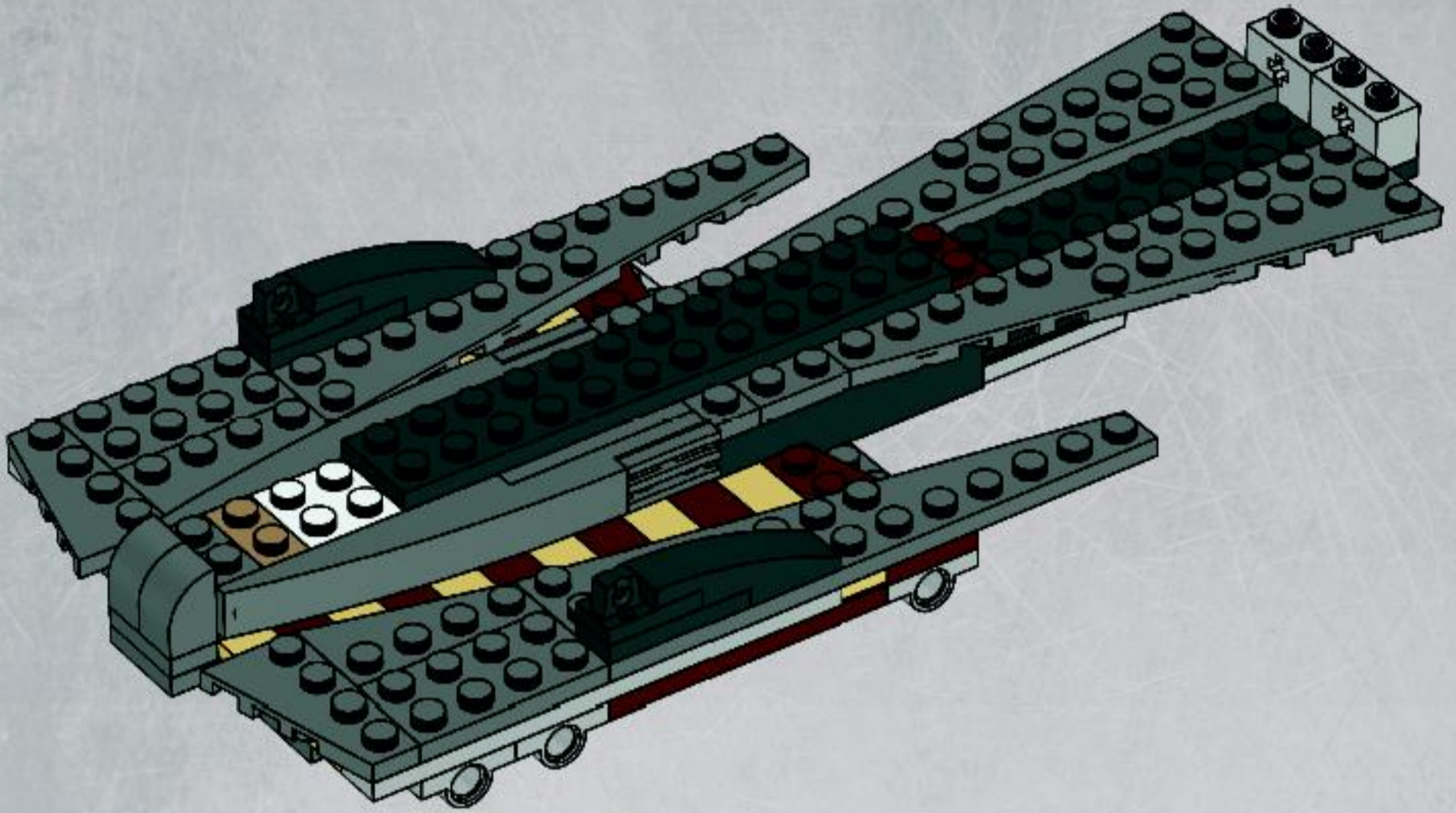

2x



1x

26

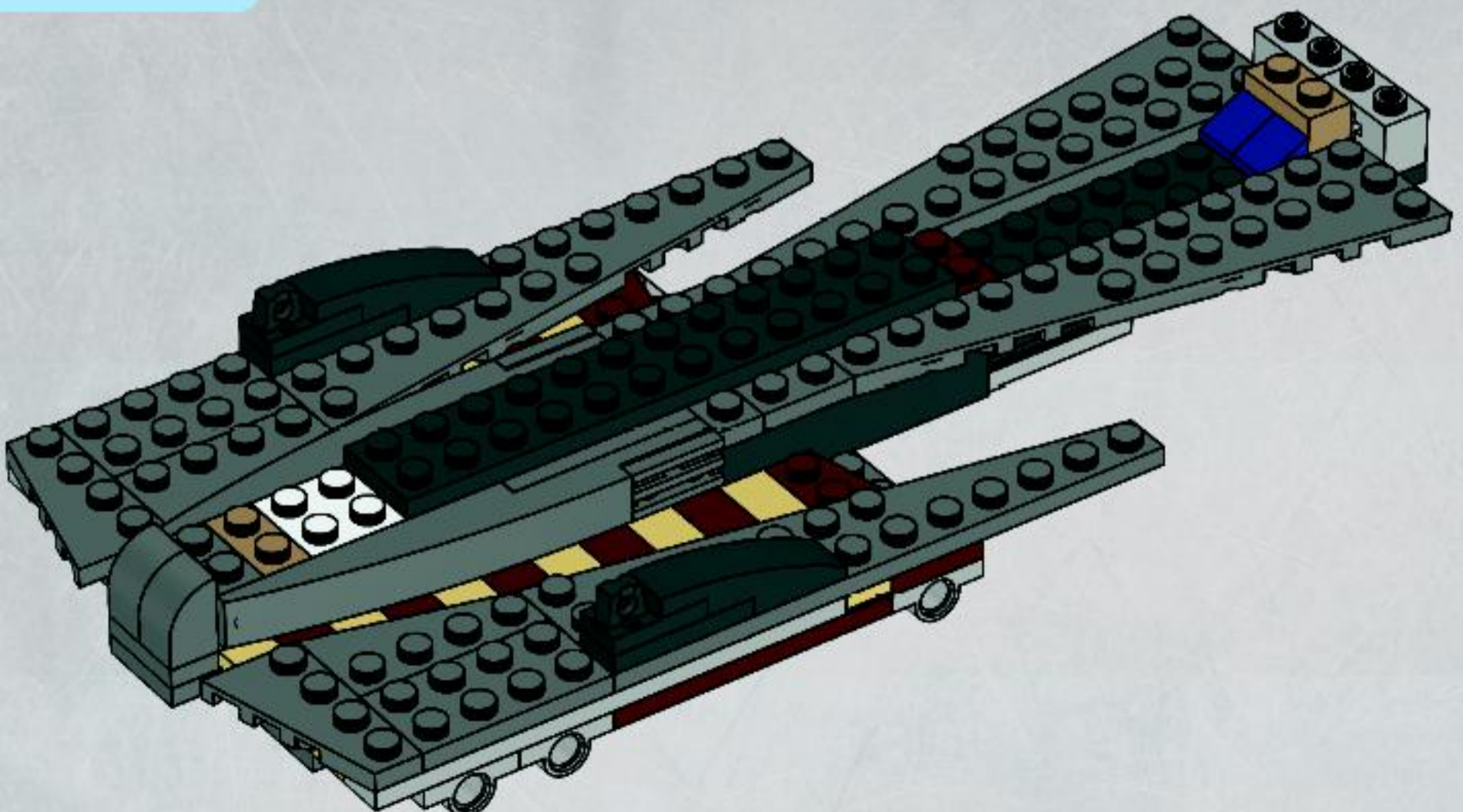



2x



4x

27

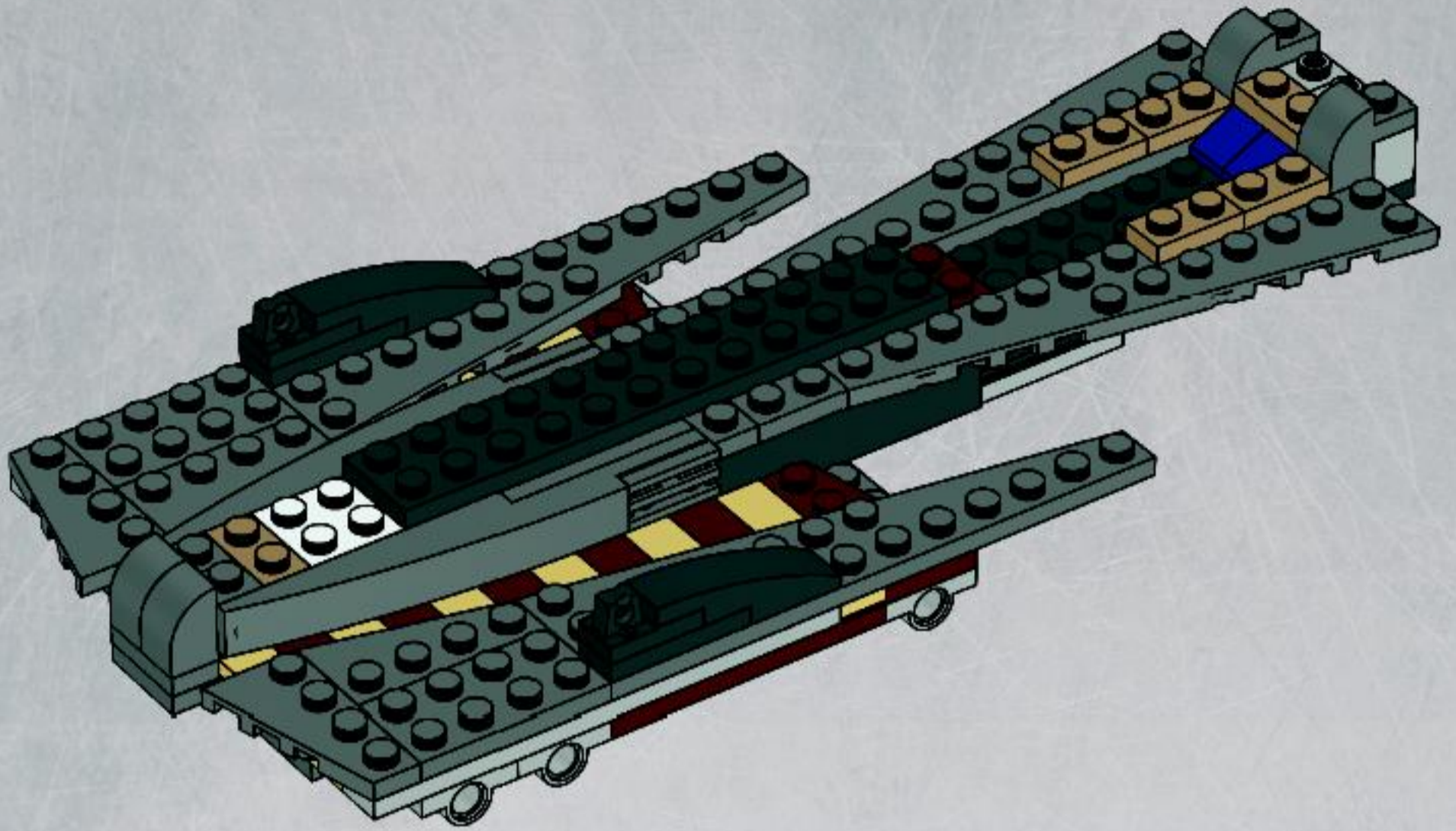

1x



1x

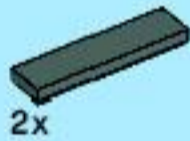

2x

28

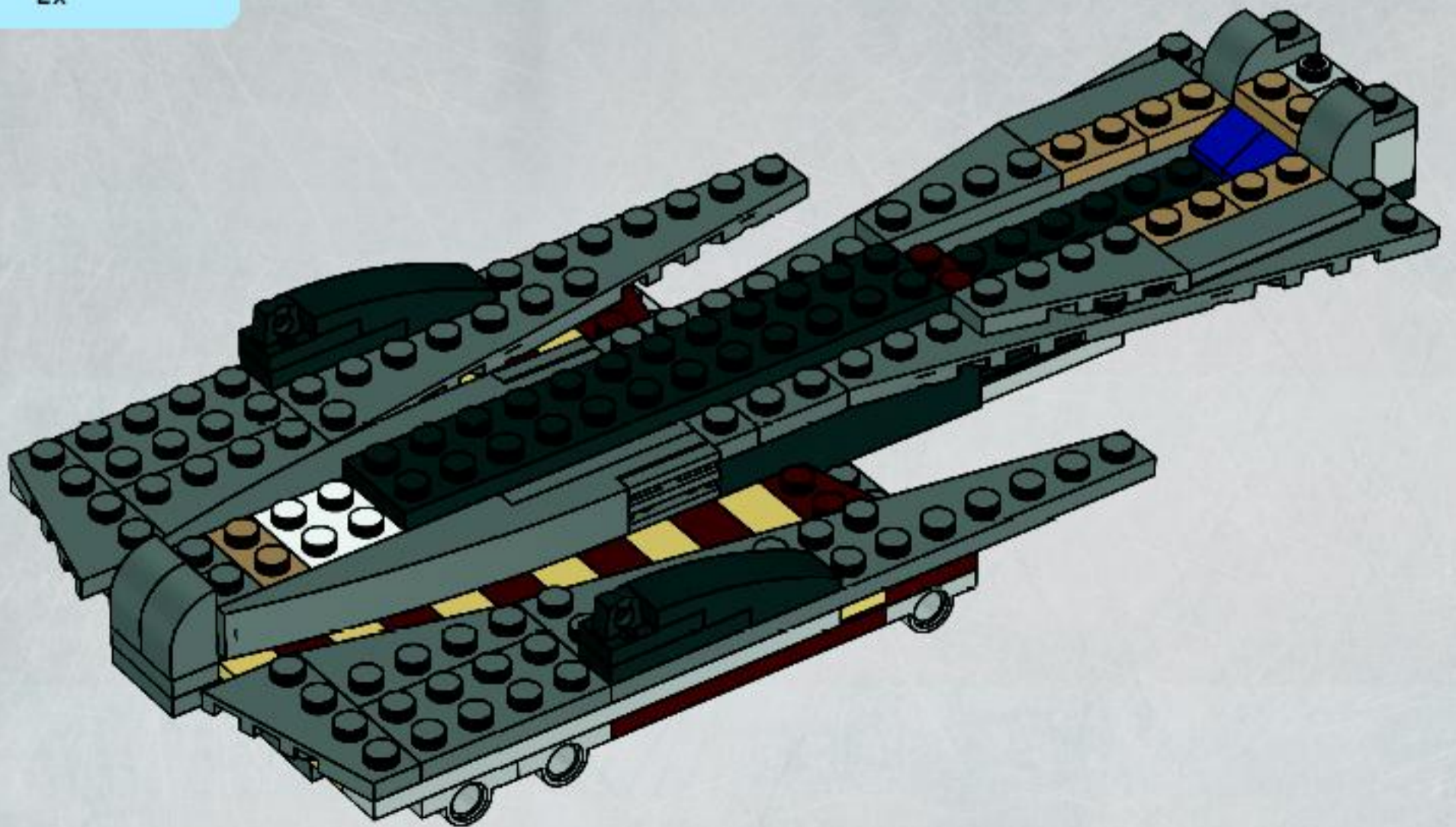

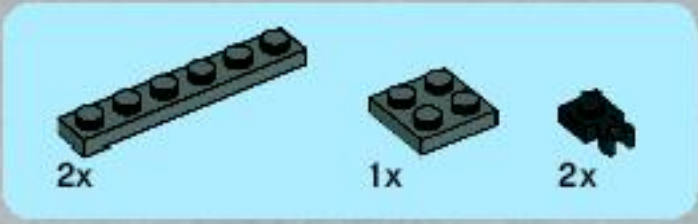

29

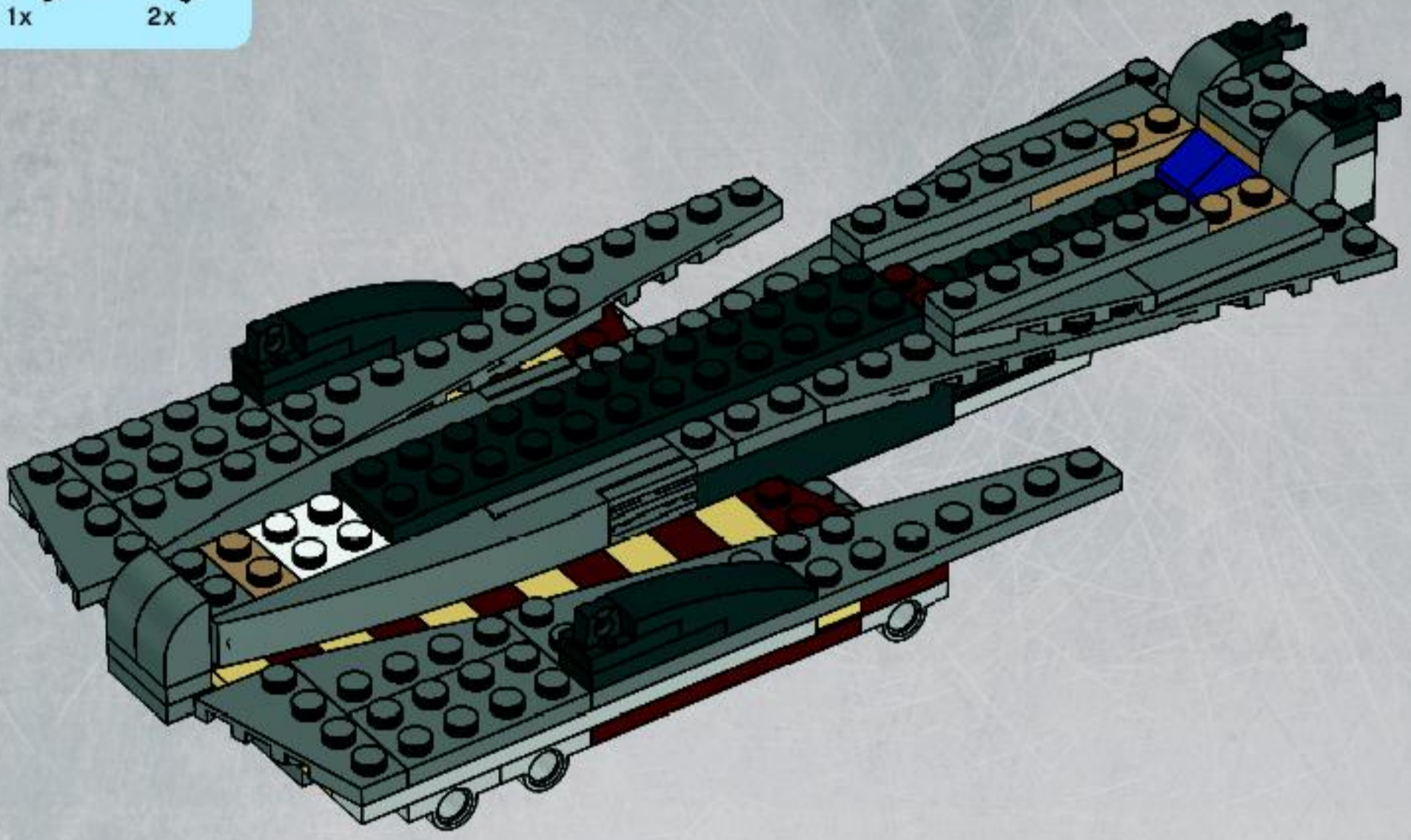

30

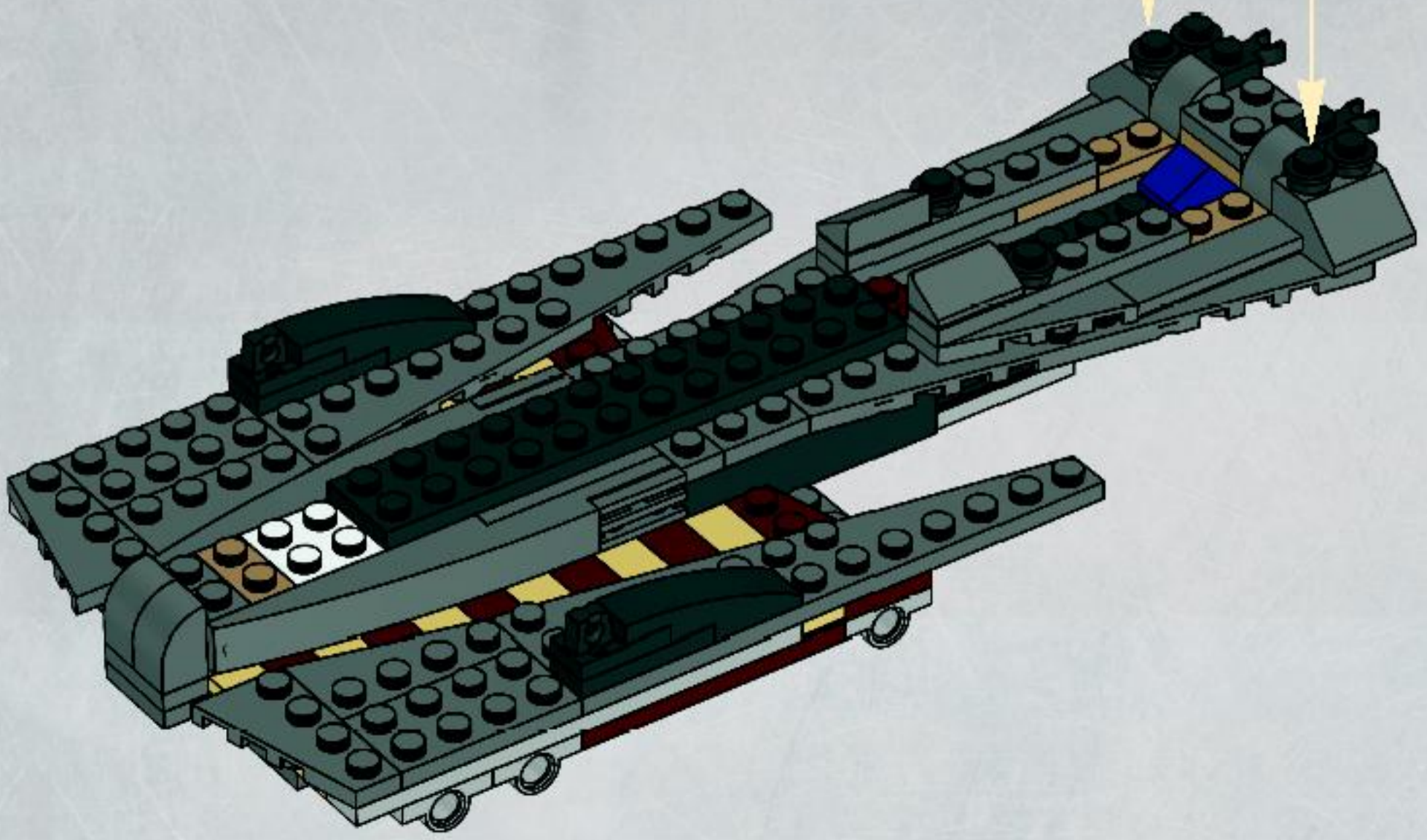
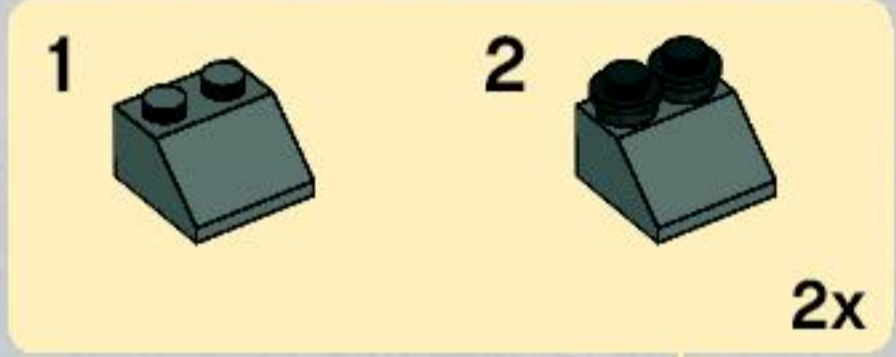



2x



1x

31

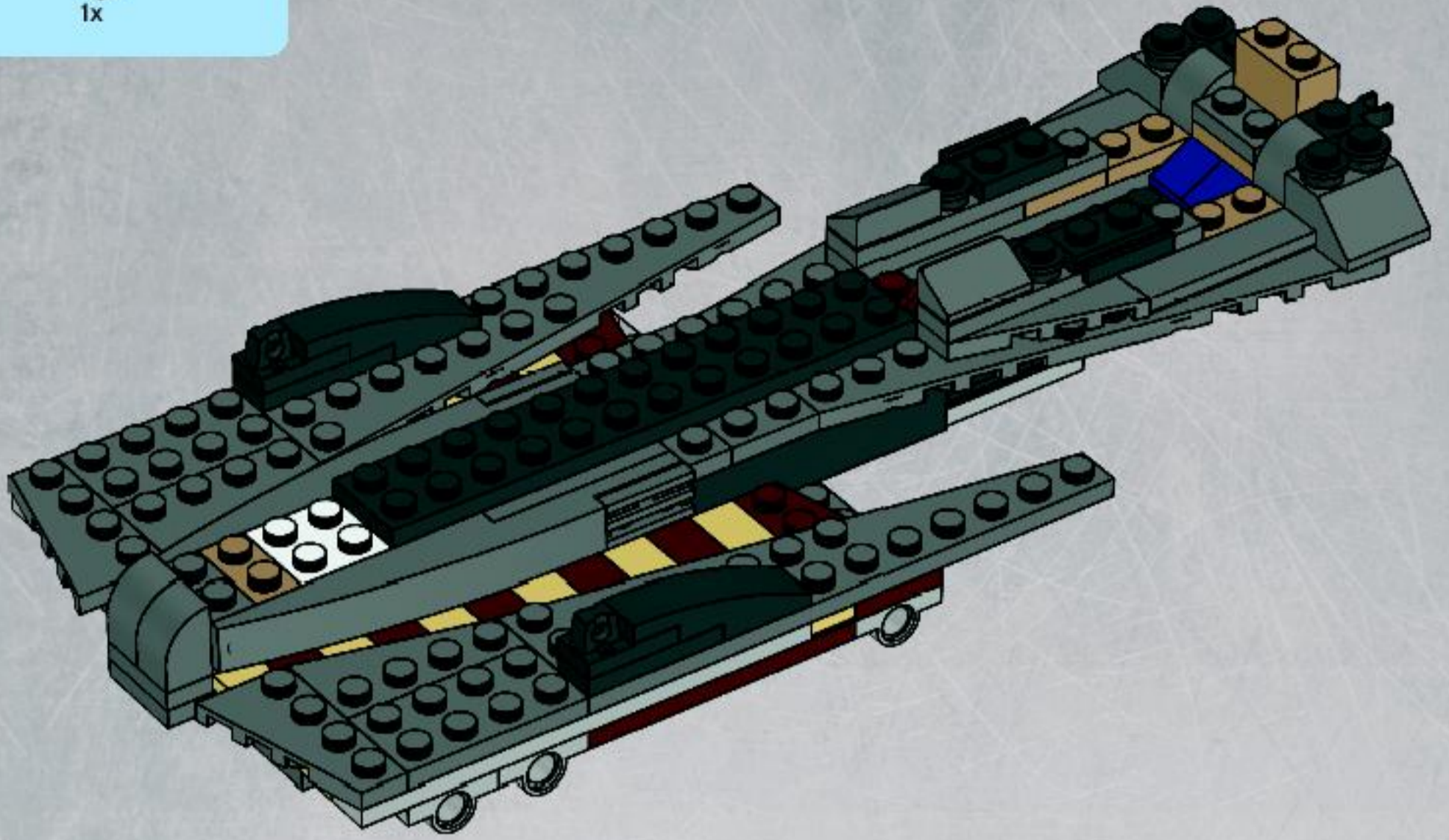

2x



2x



2x

32

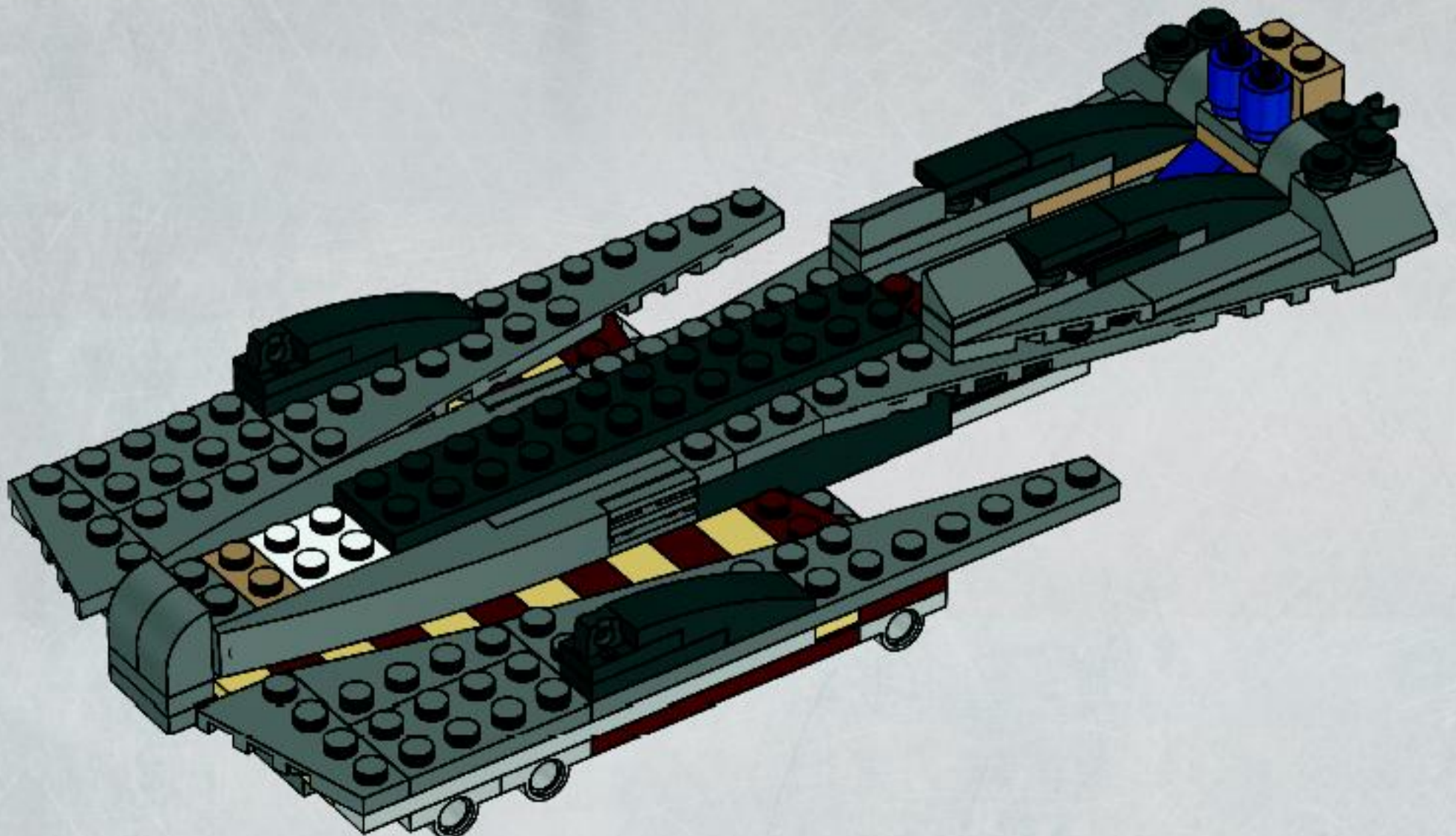

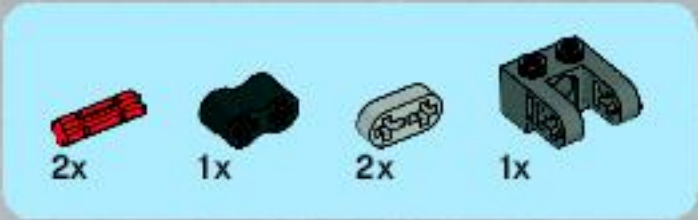

33

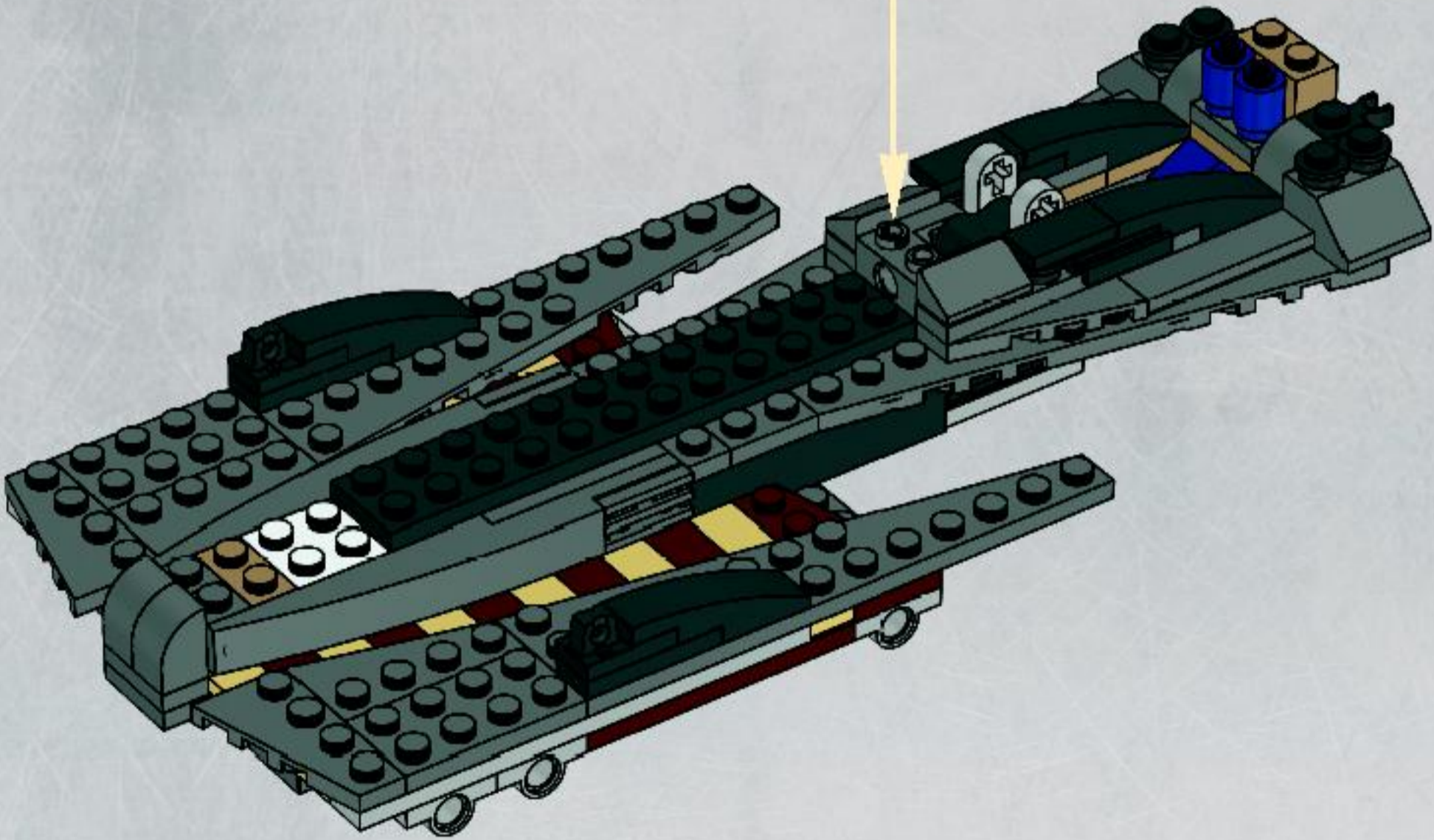
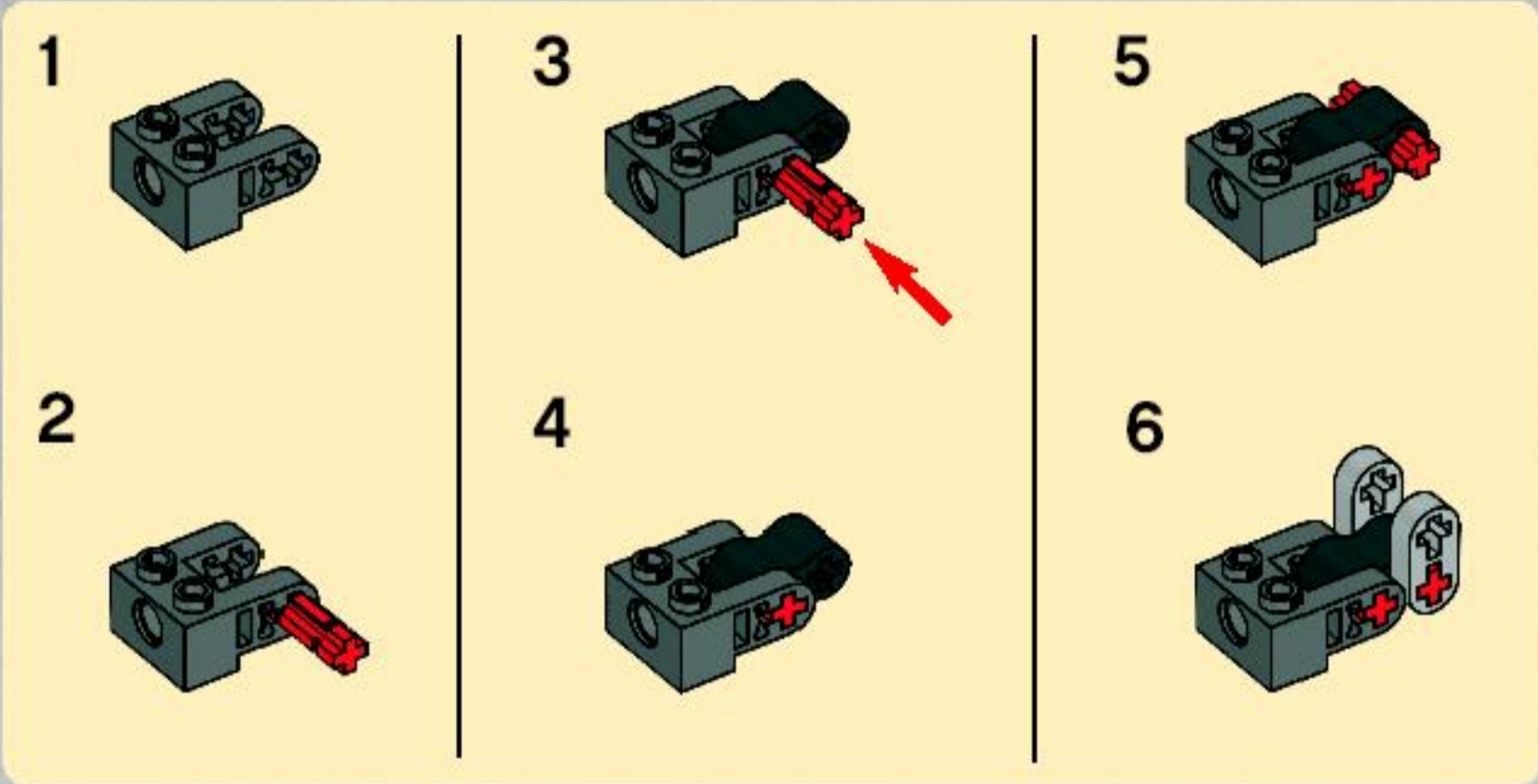

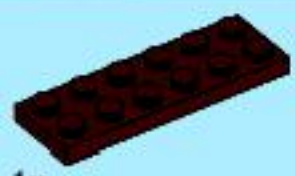

1x

34

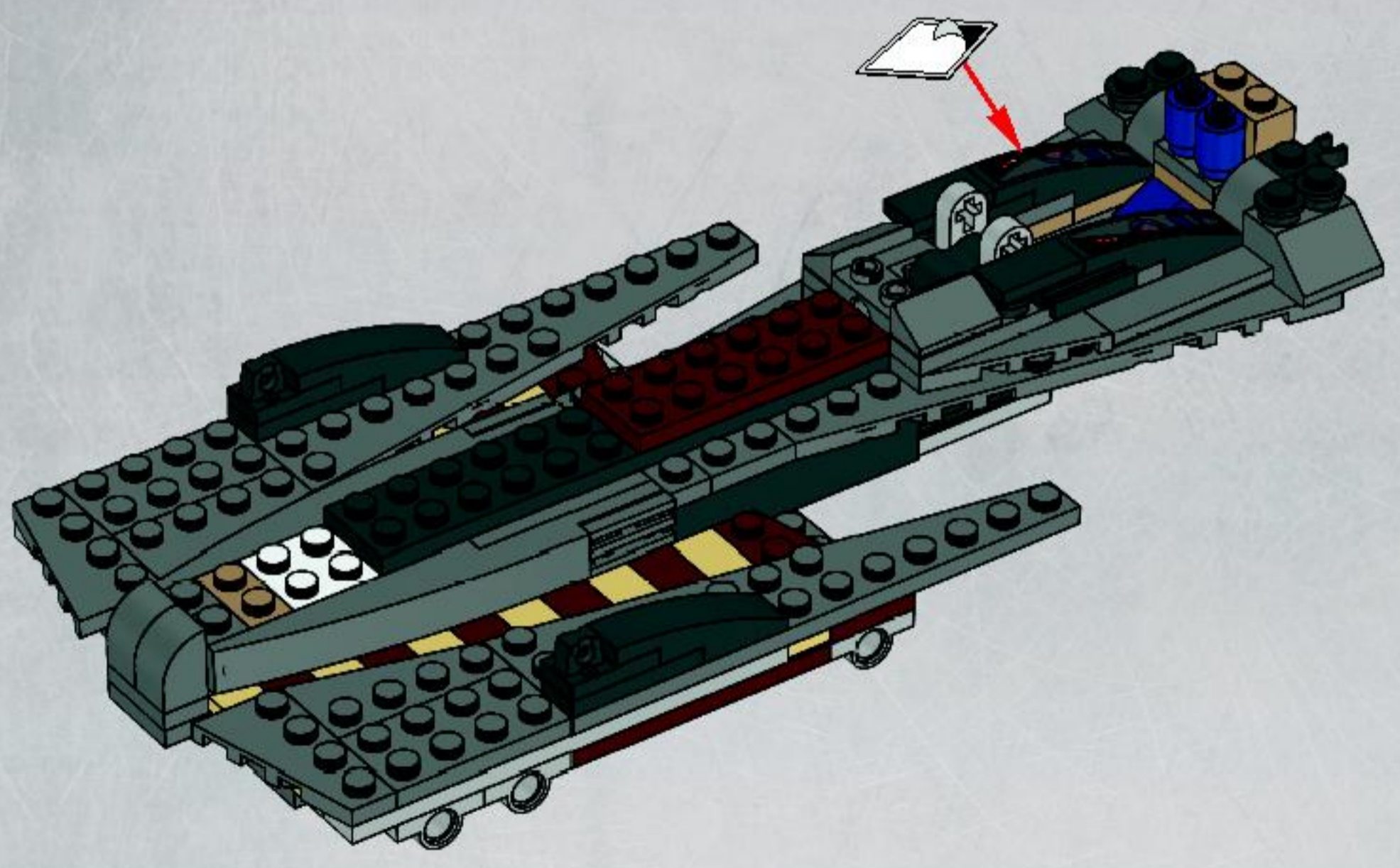

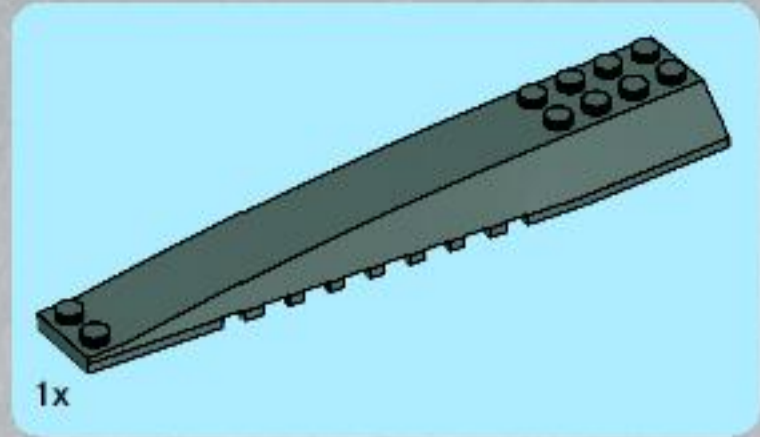

35

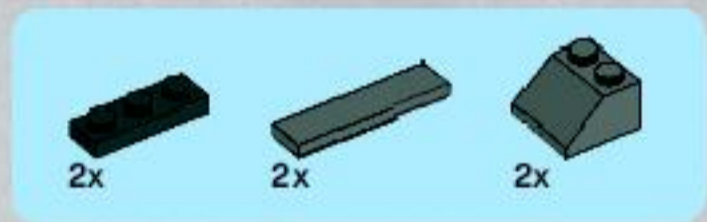
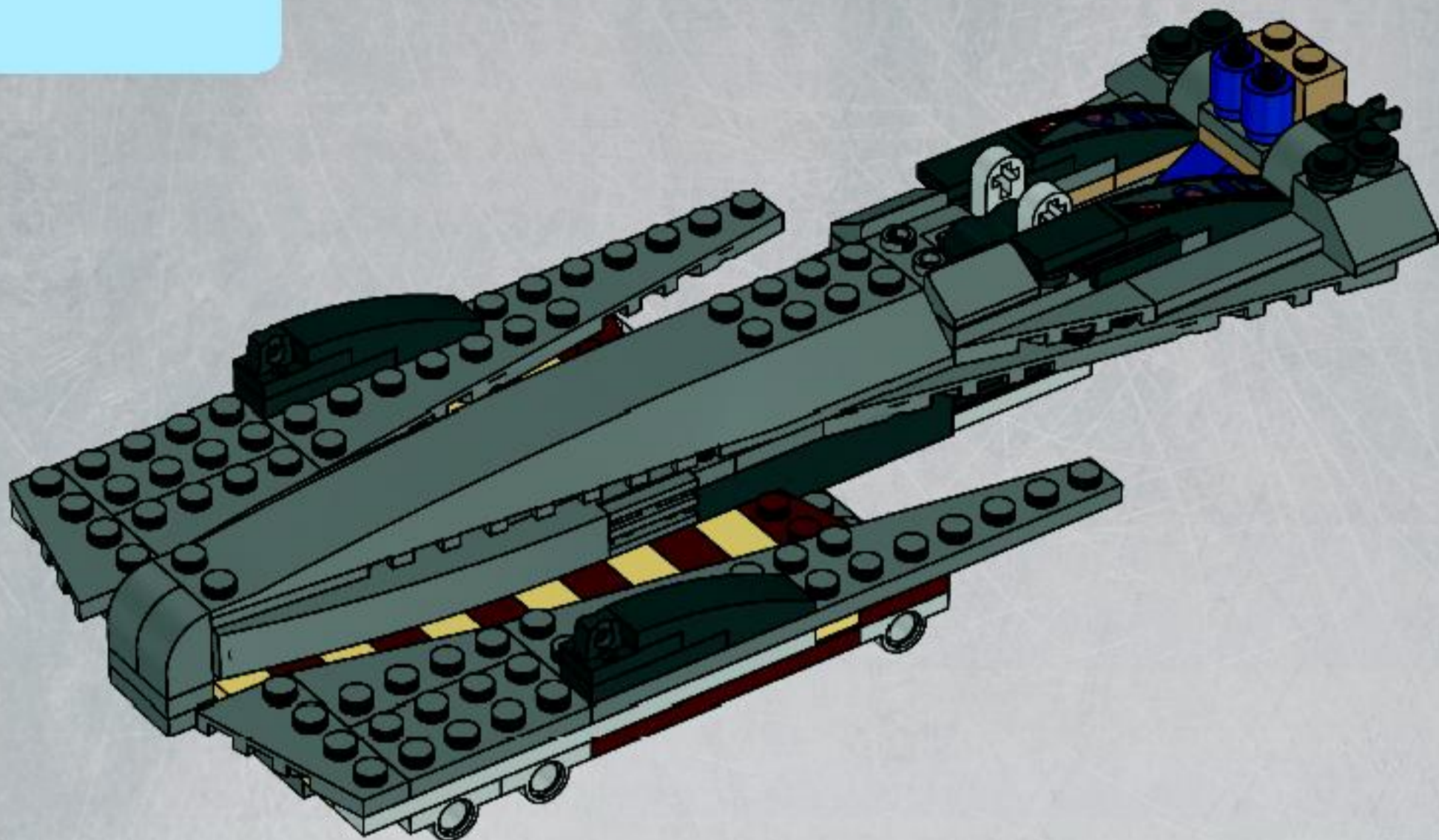

36

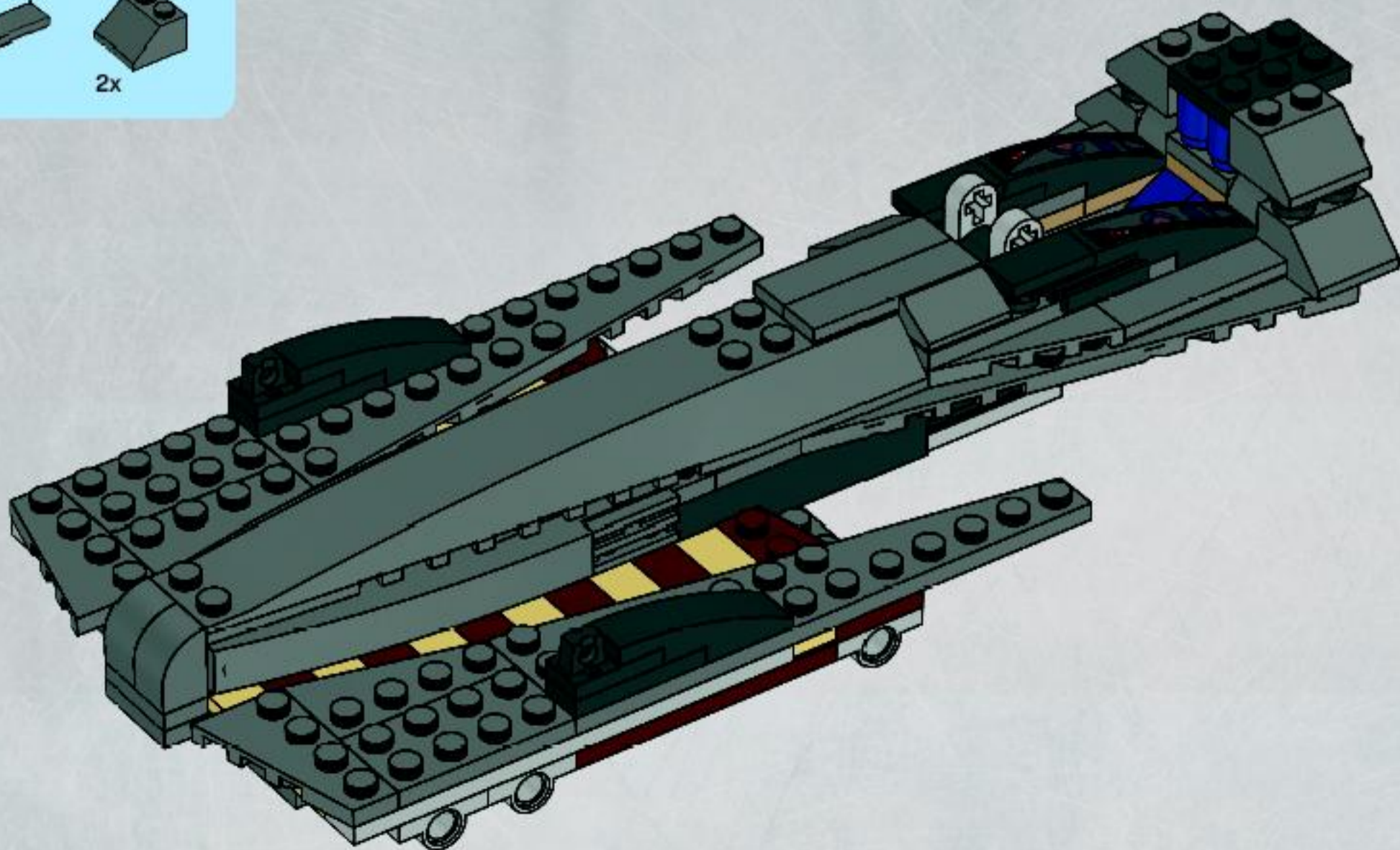

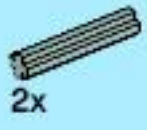

2x

37

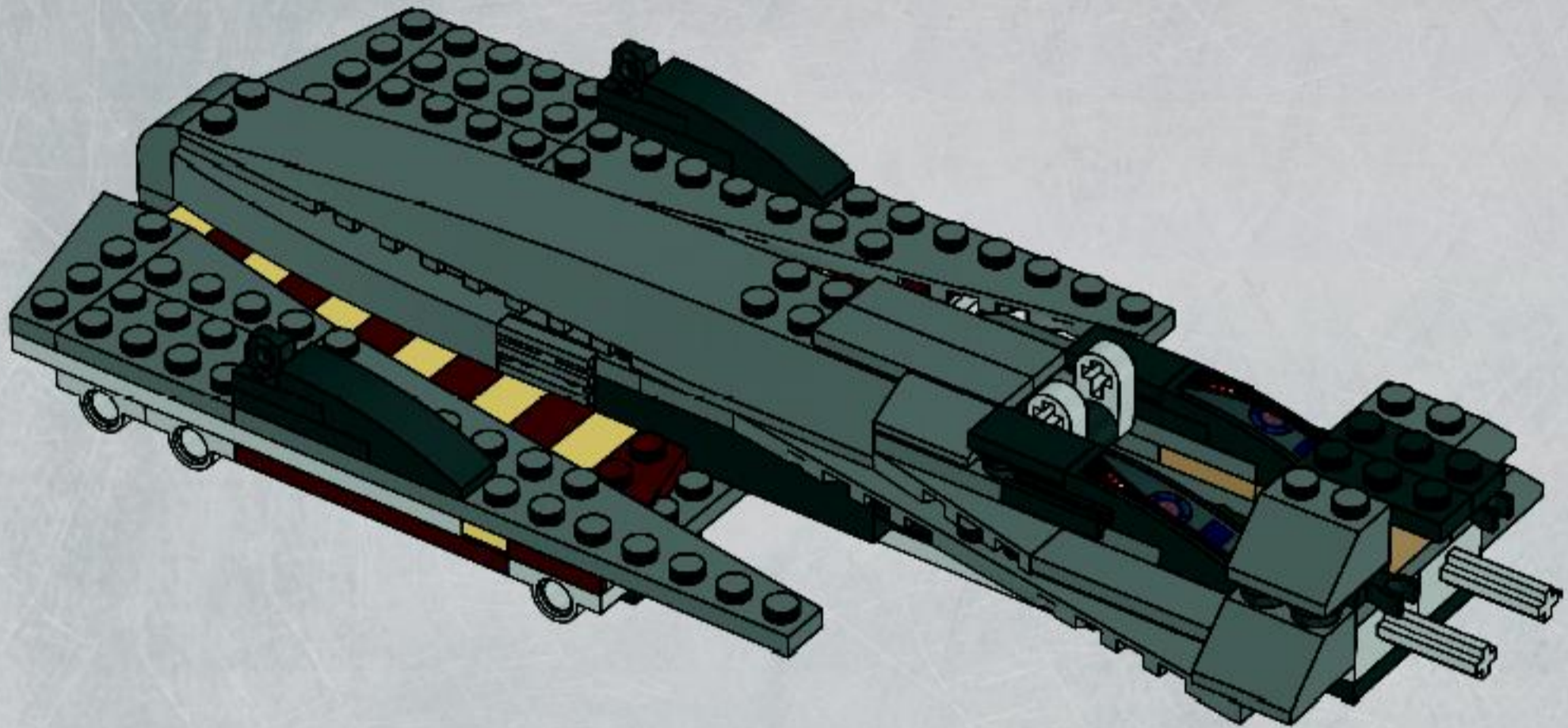



1x

38

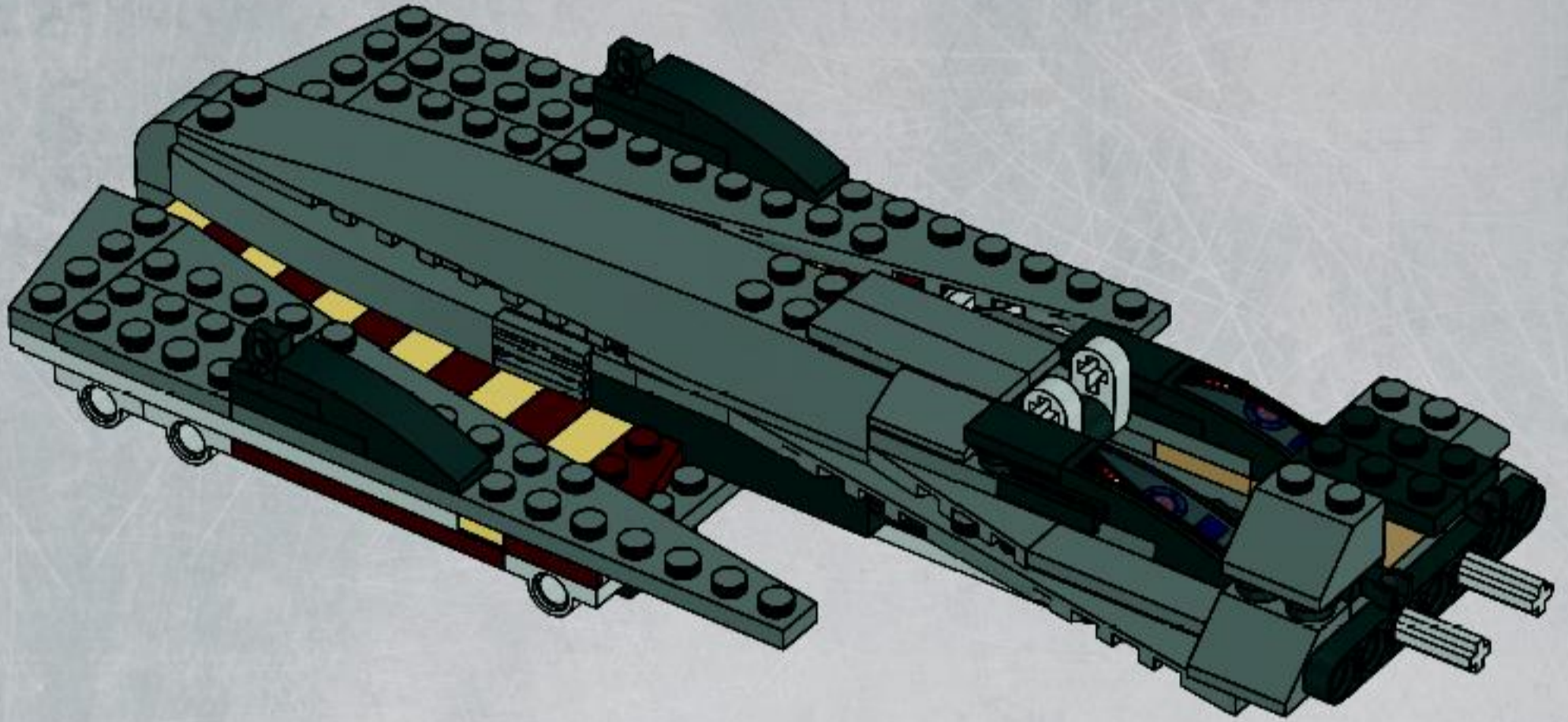

2x

39

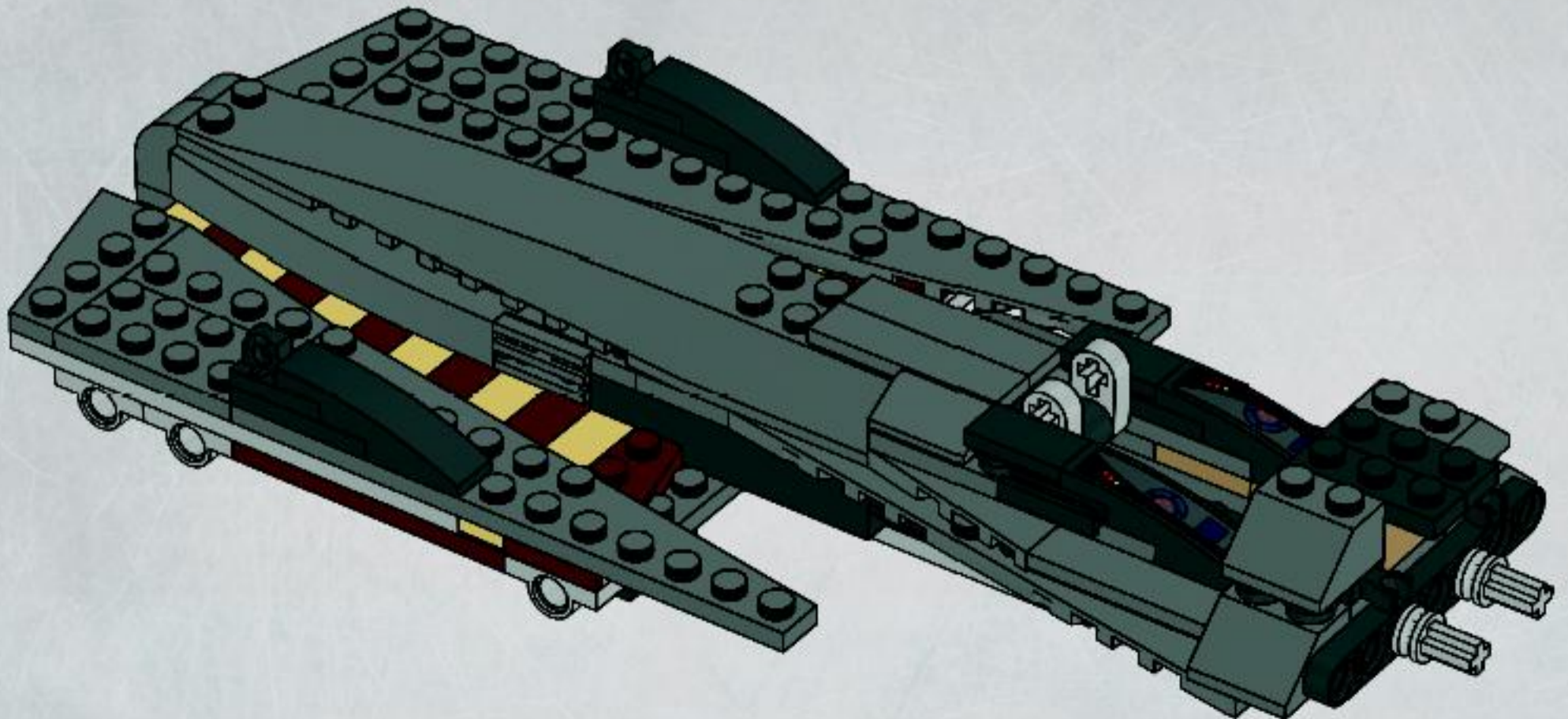



2x

40

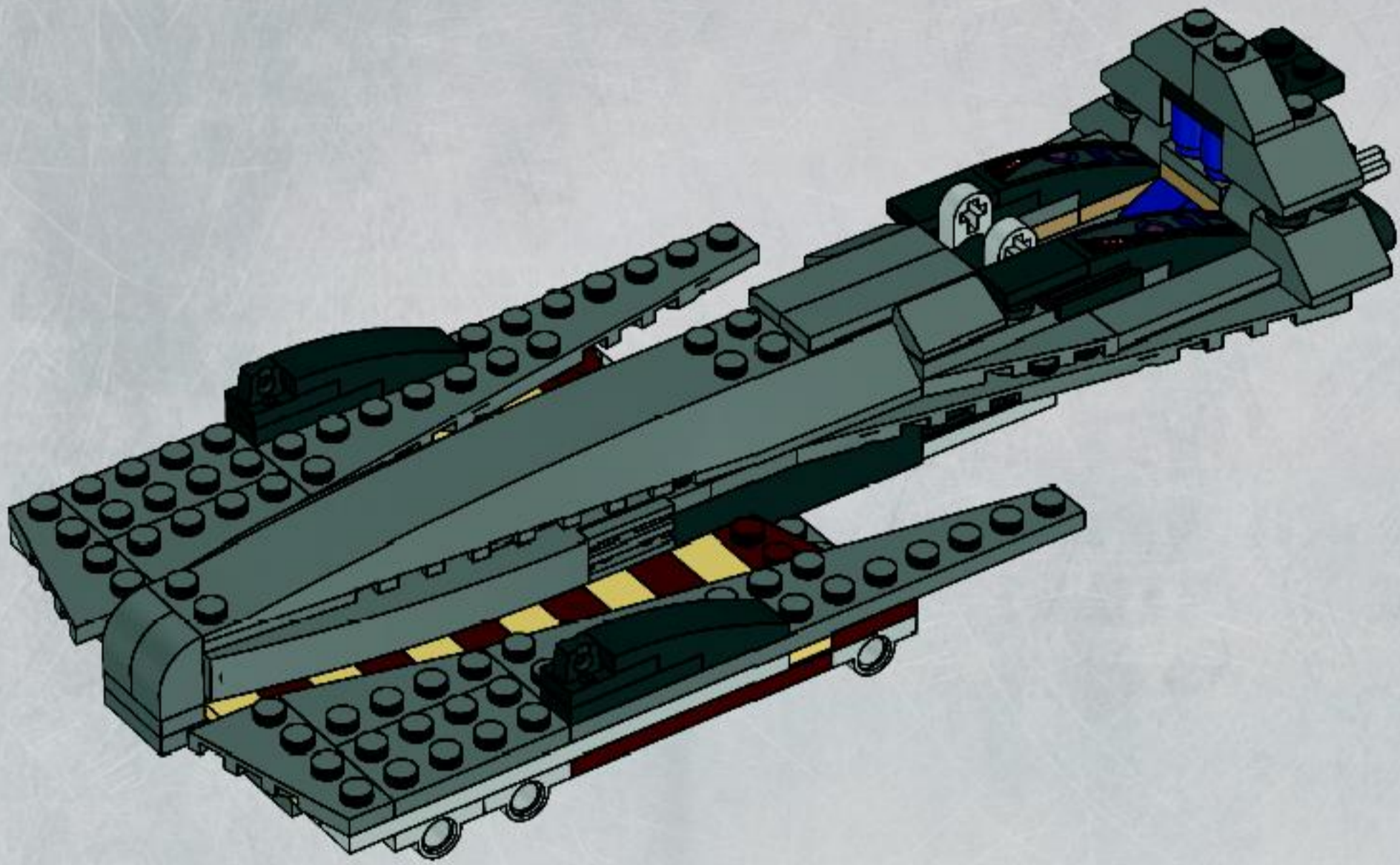

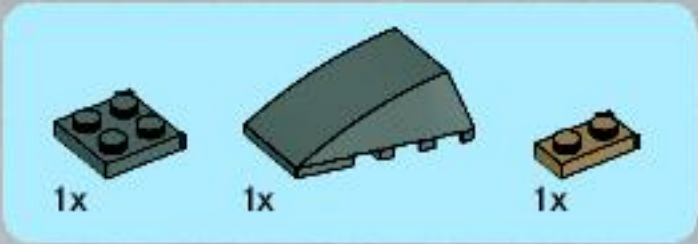

41

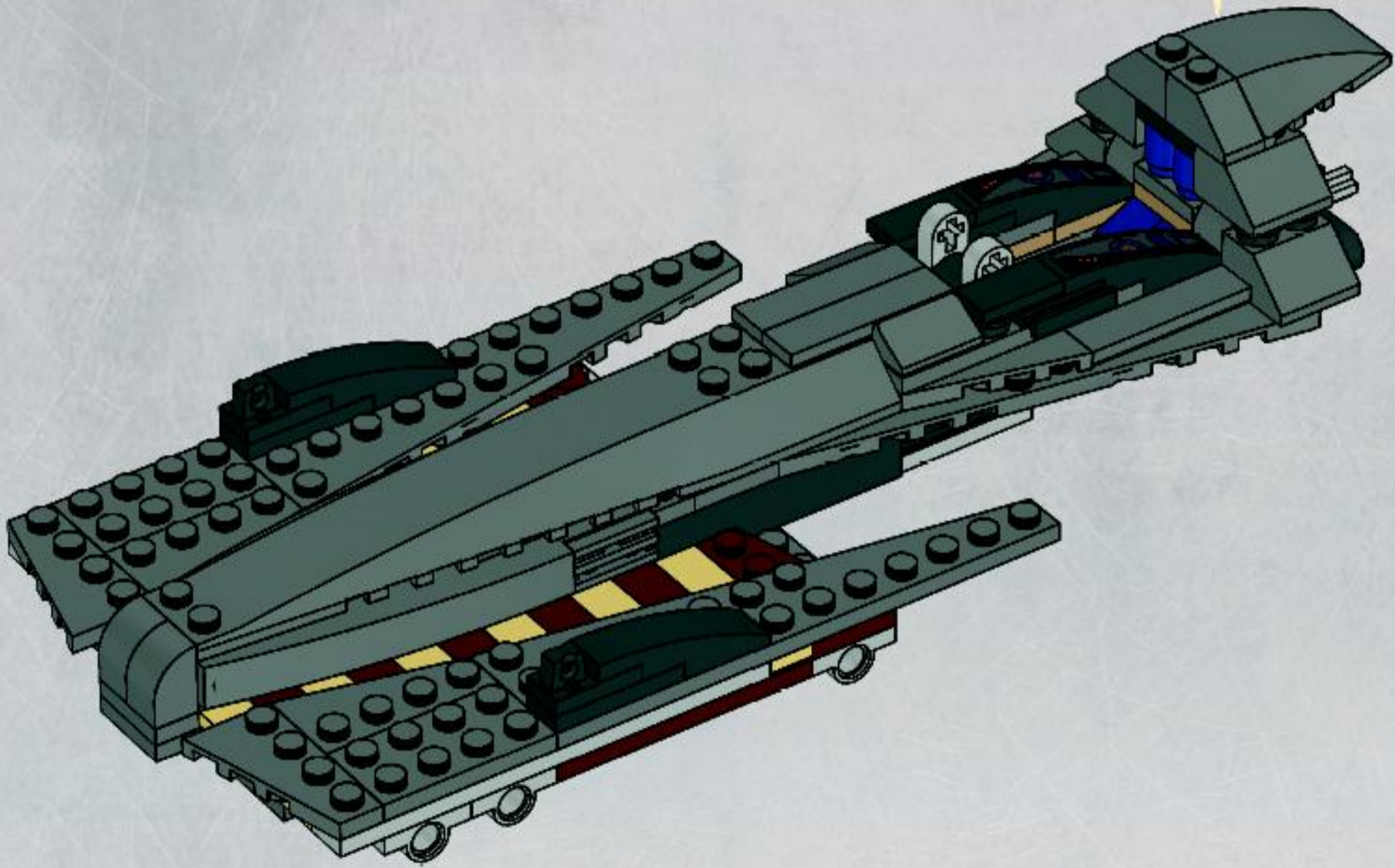
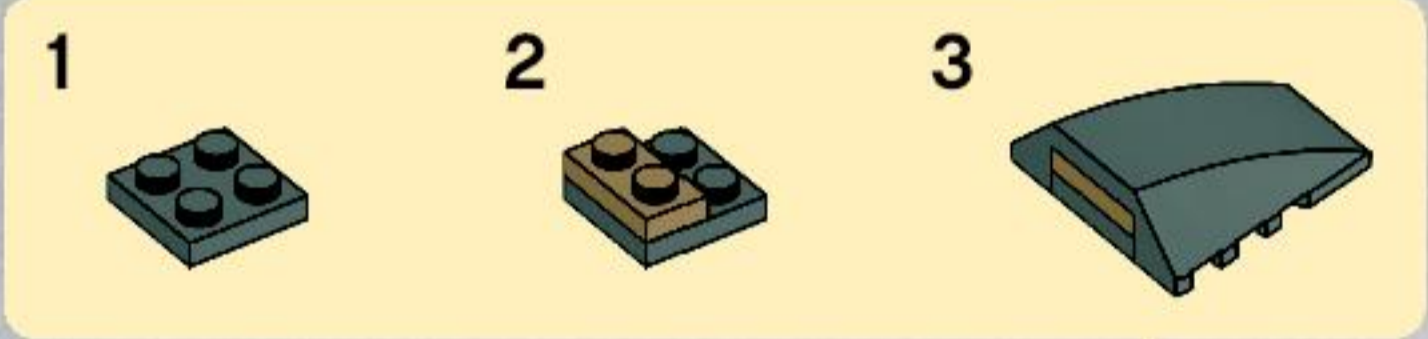



2x



1x

42

1

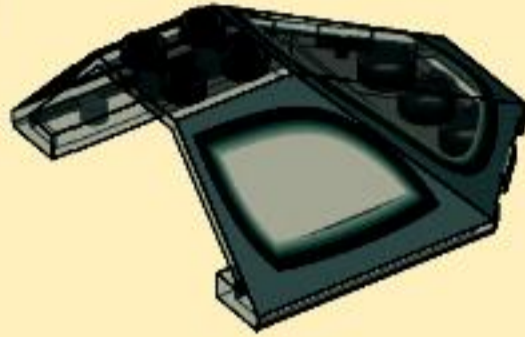

2

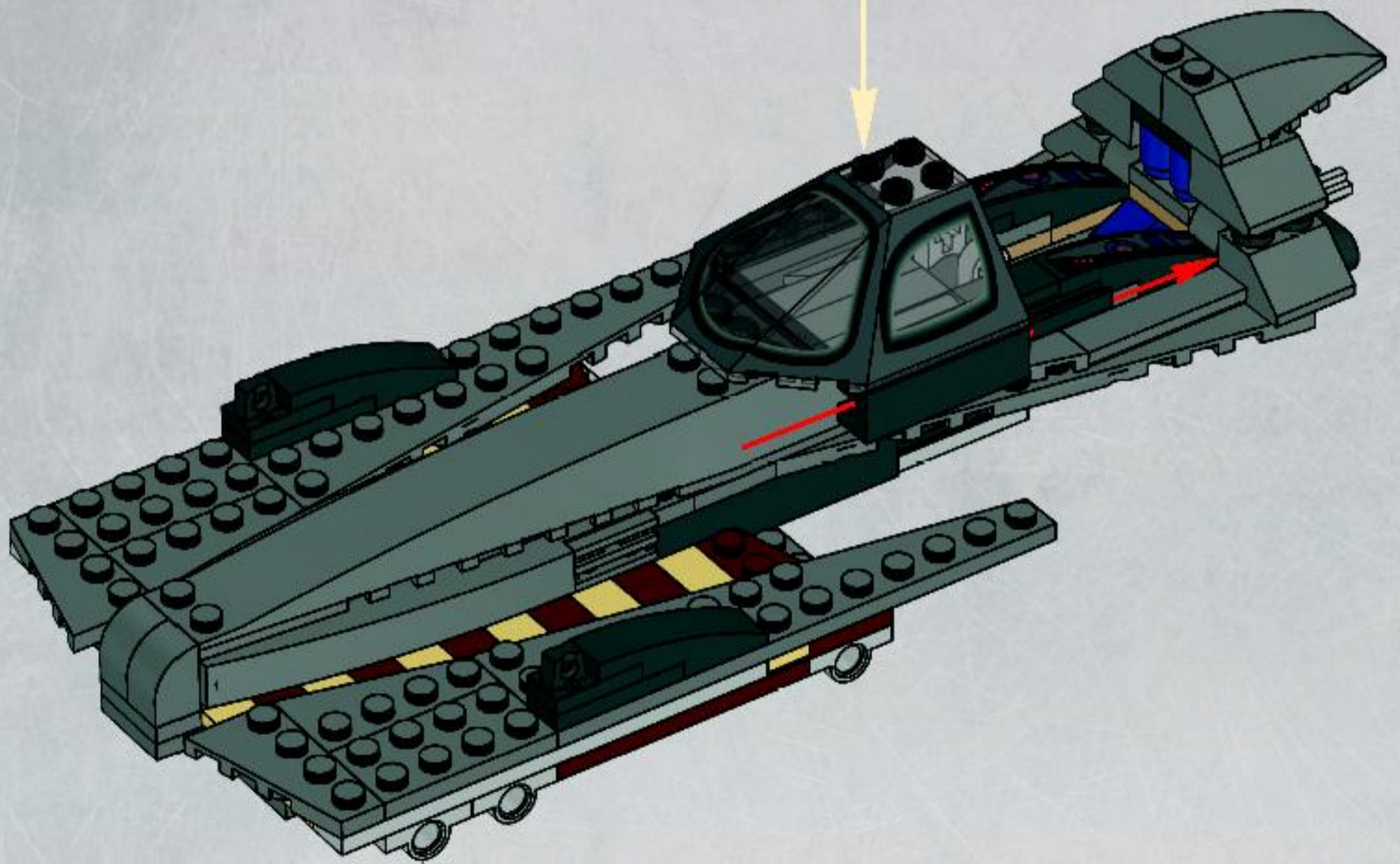



1x

43

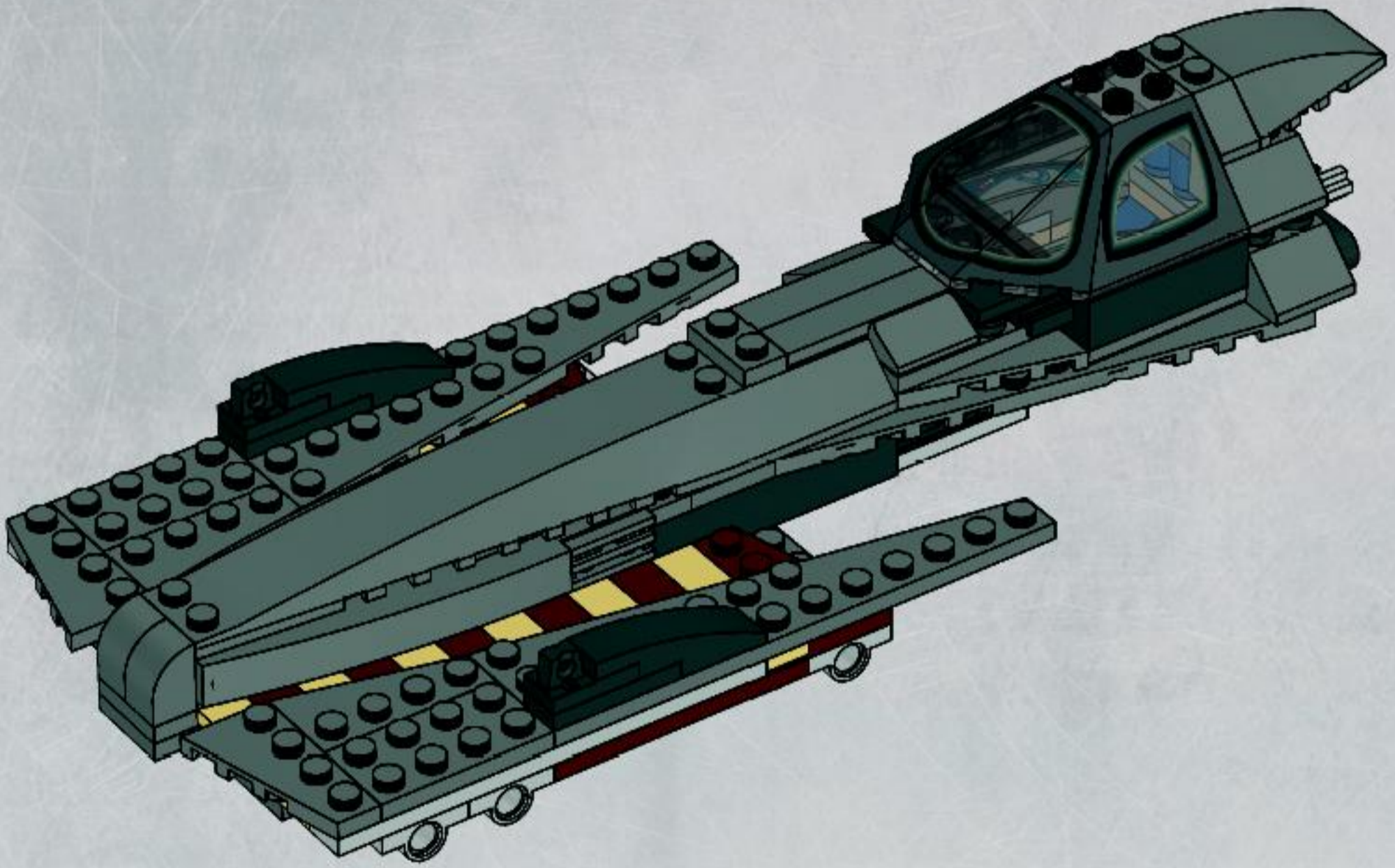

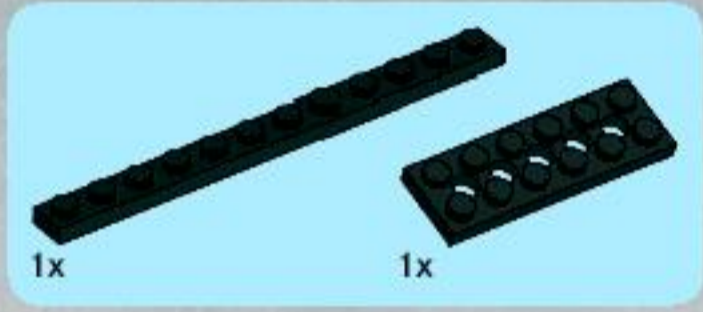
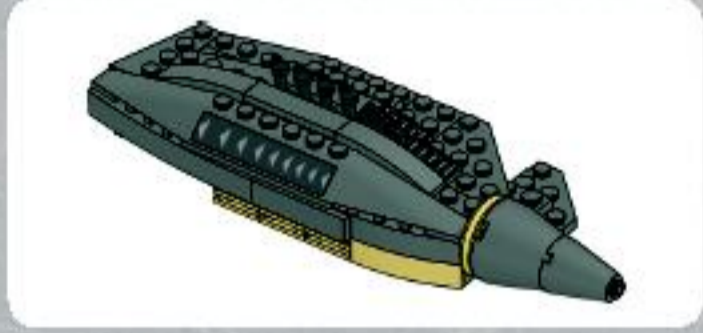
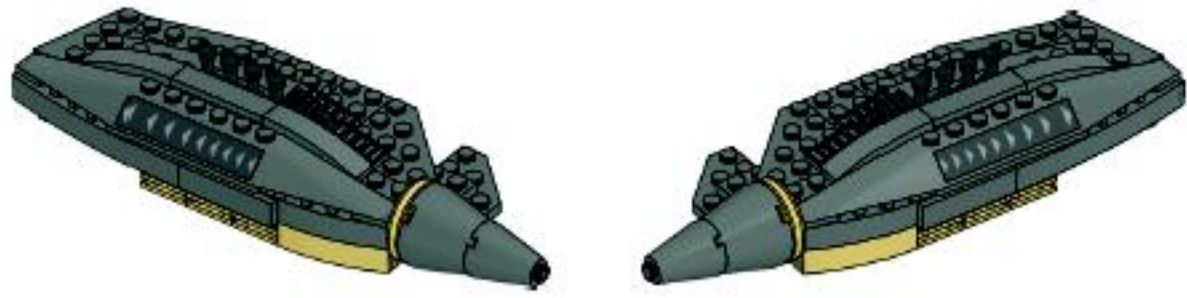

1

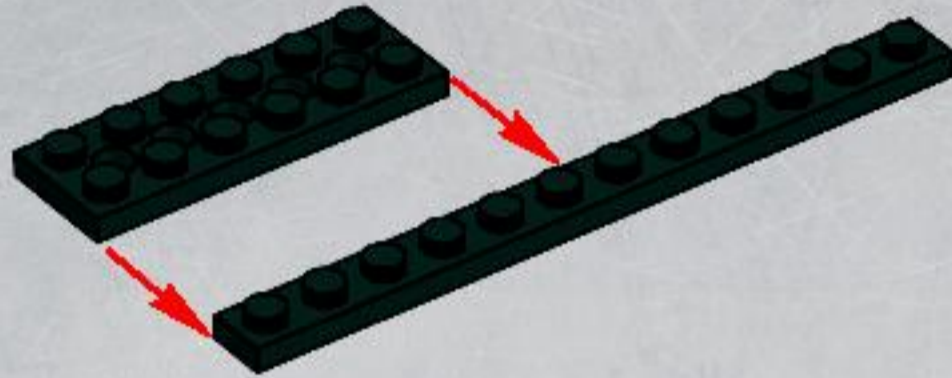

2



3

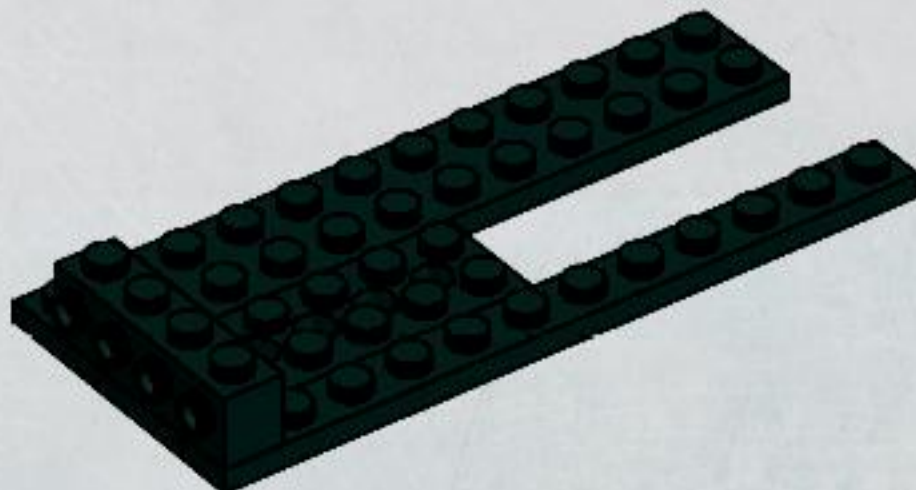



3x

4

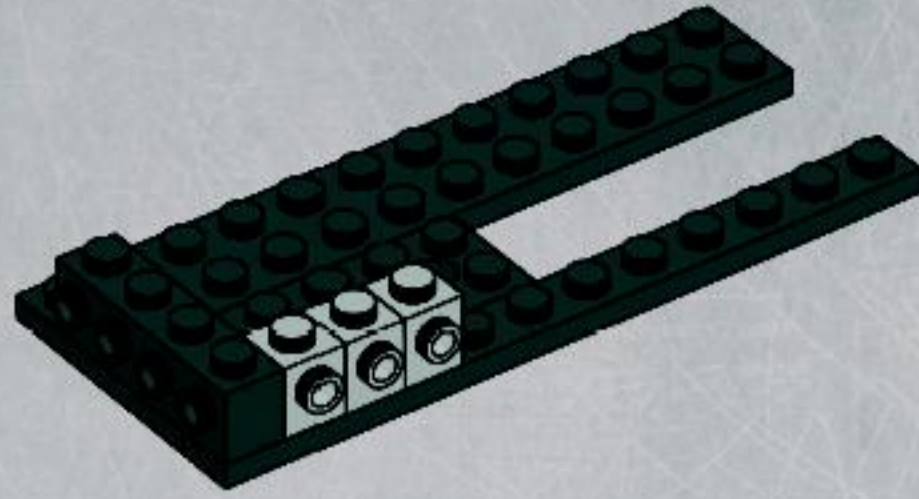

1x



1x

5

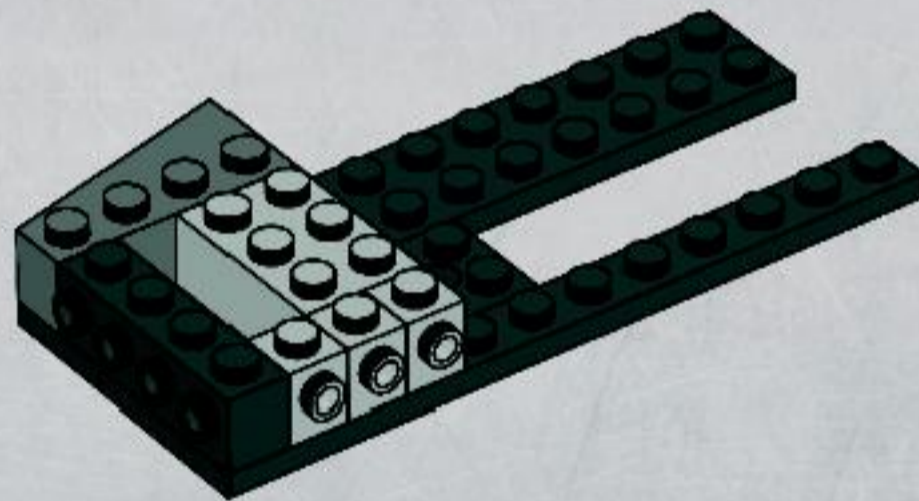

1x



2x



1x

6

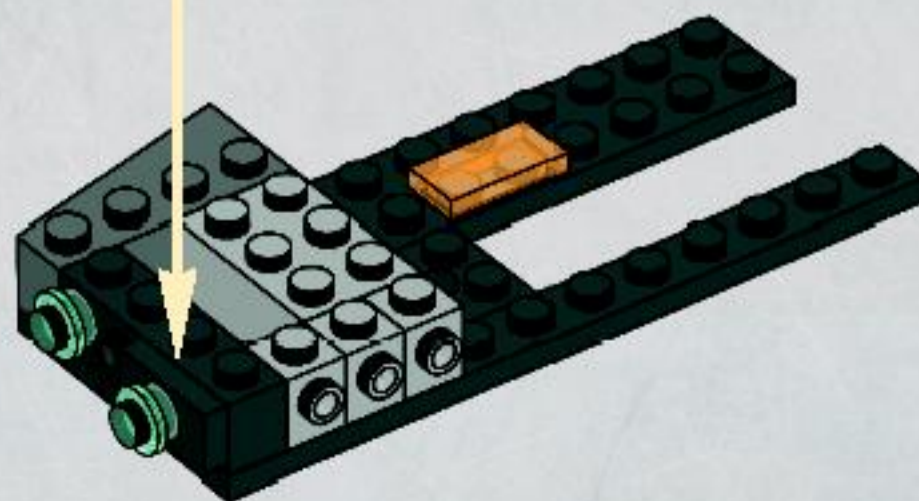

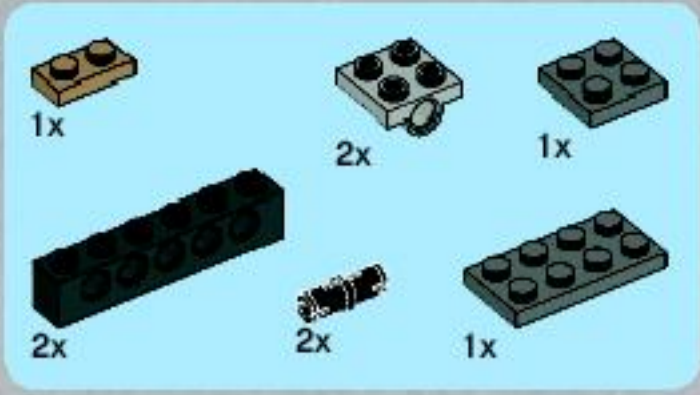

7

1

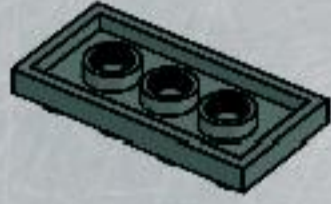

2

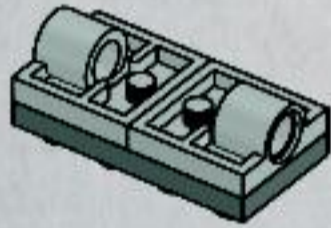

3

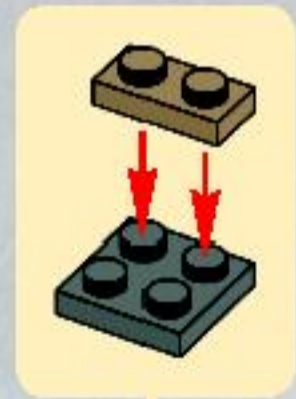

4



5

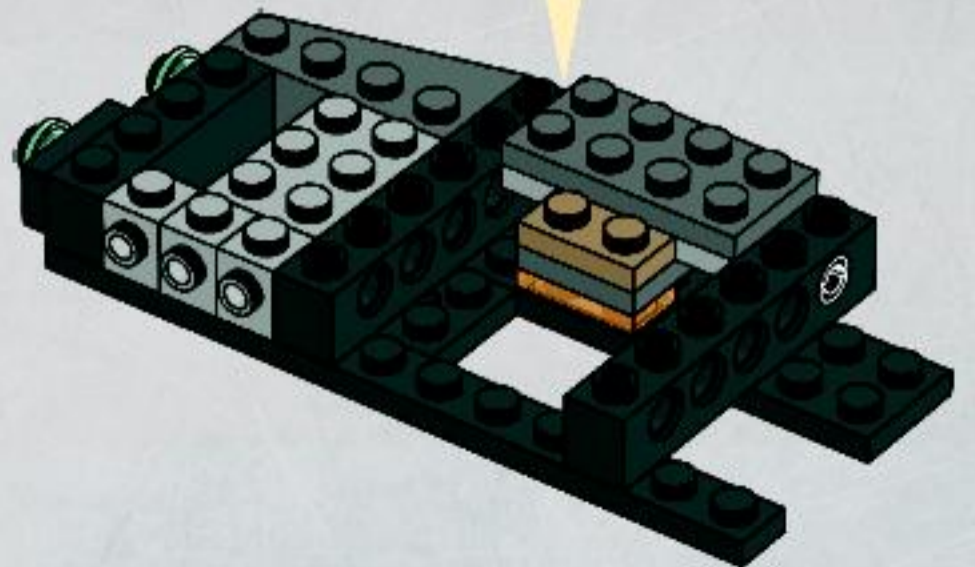
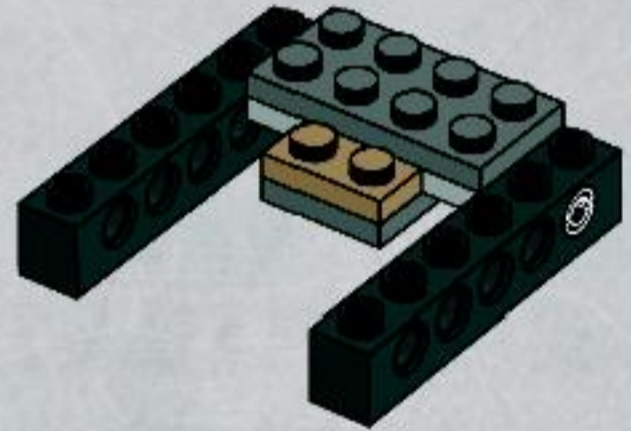



2x

8

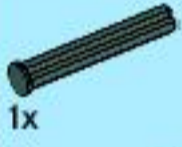
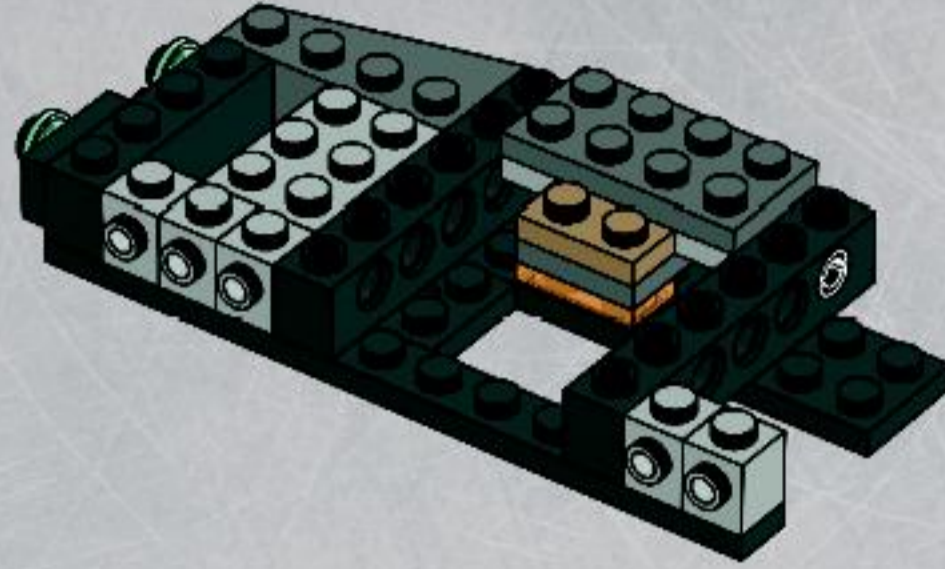

1x



1x



1x



1x

9

1



2



3

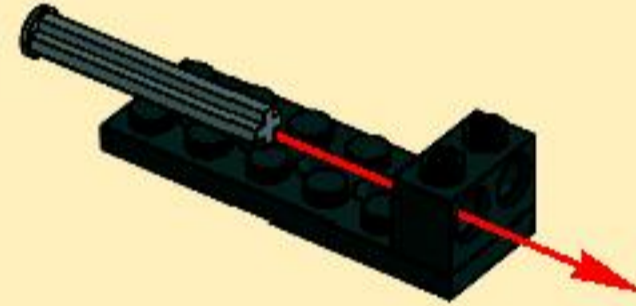

4

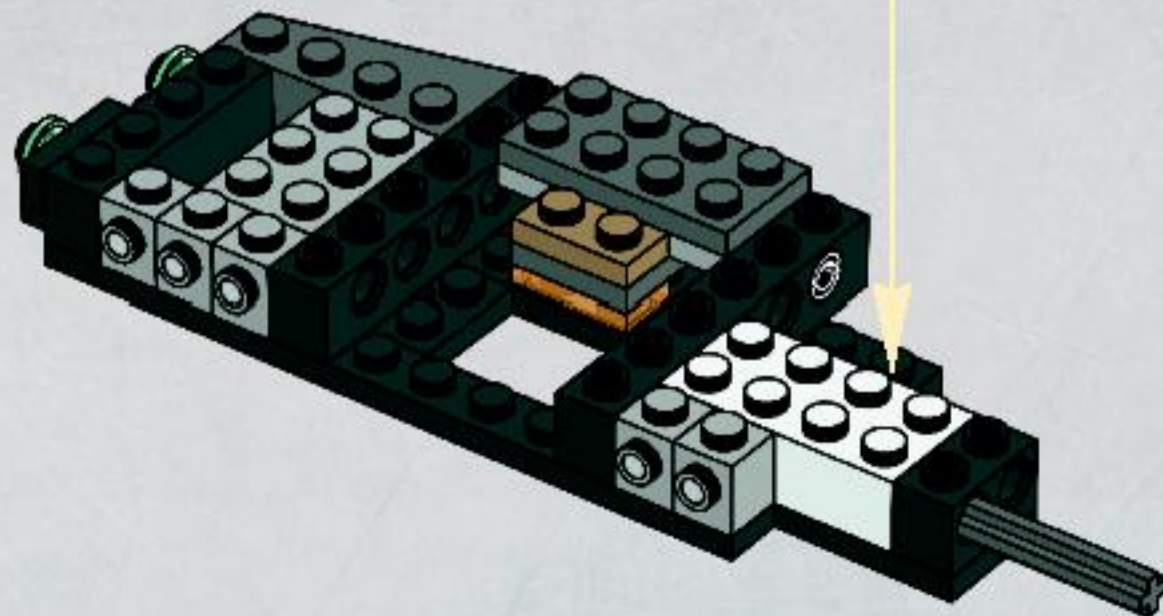
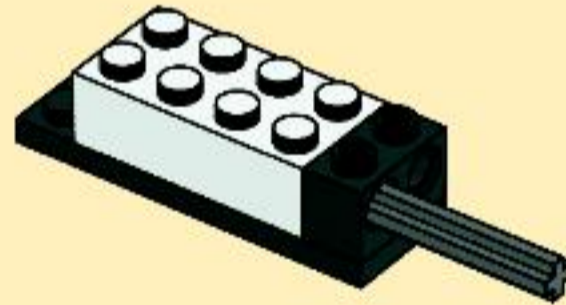

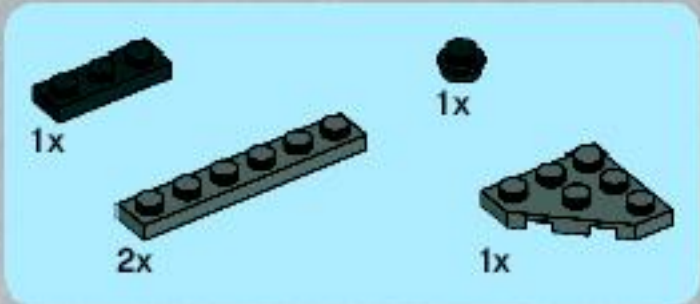

10

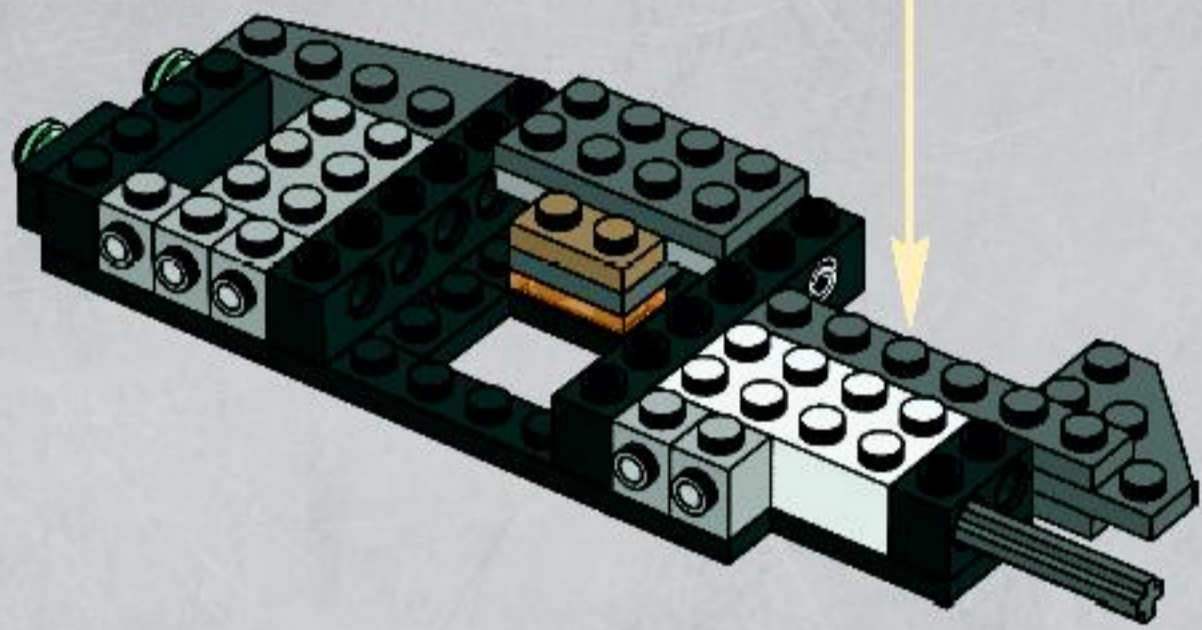
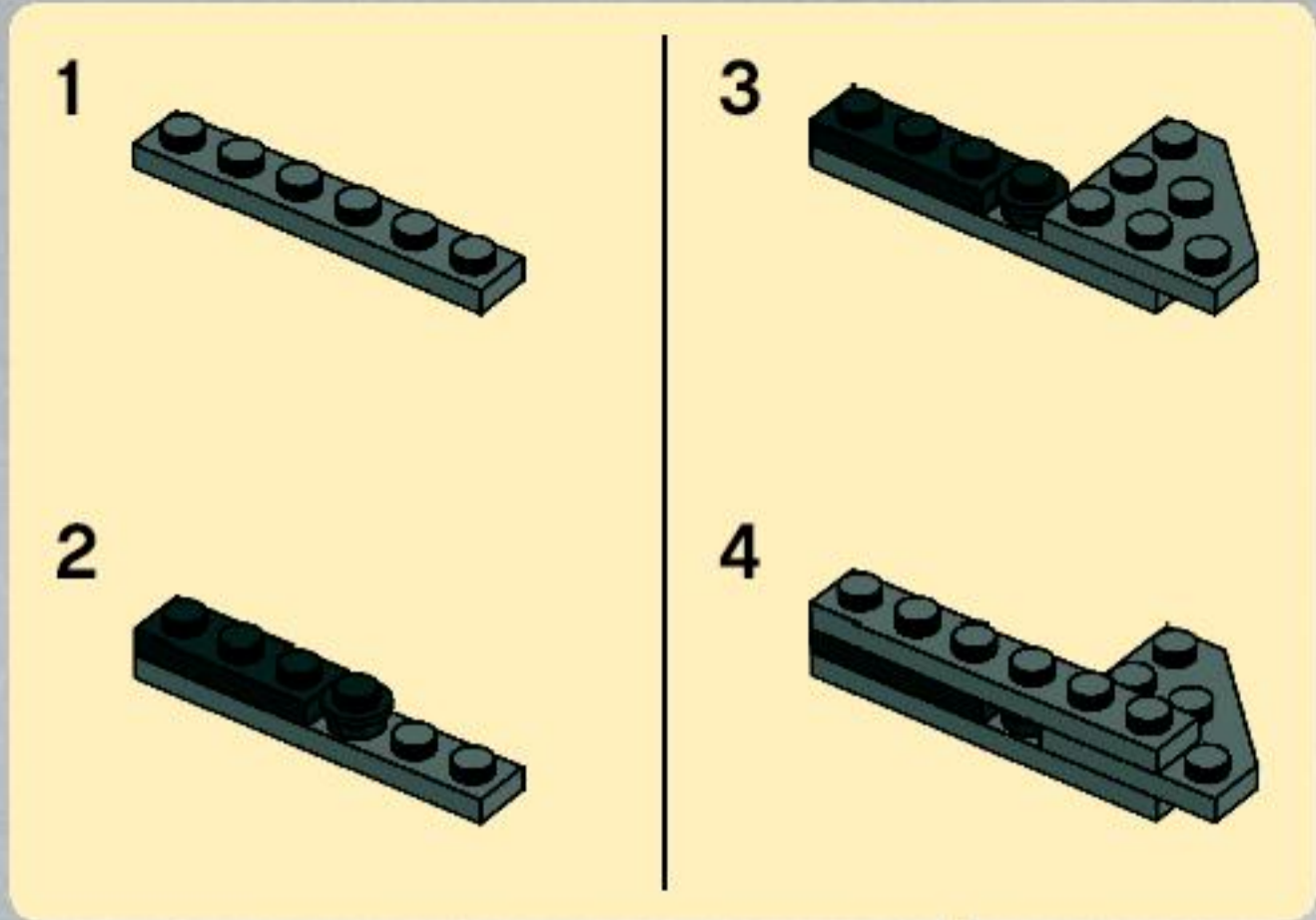

11

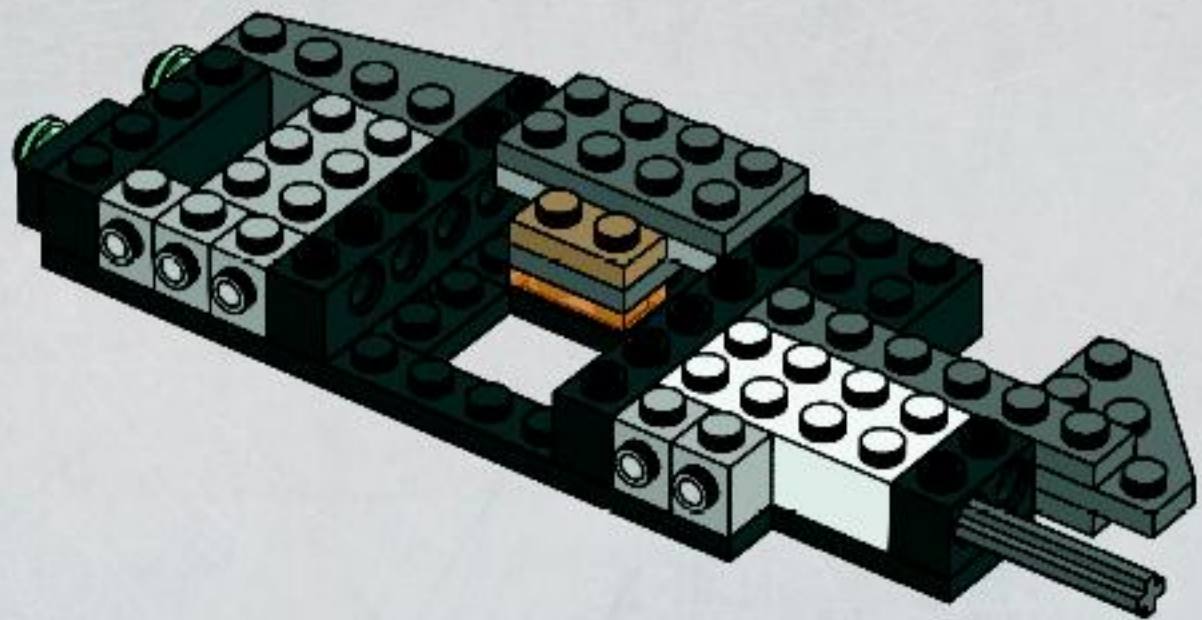

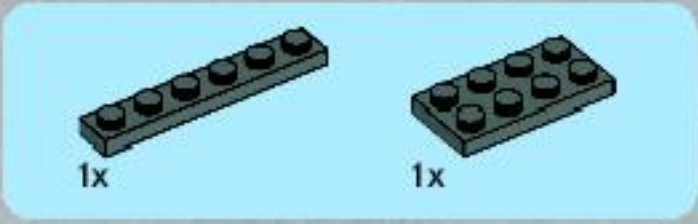

12

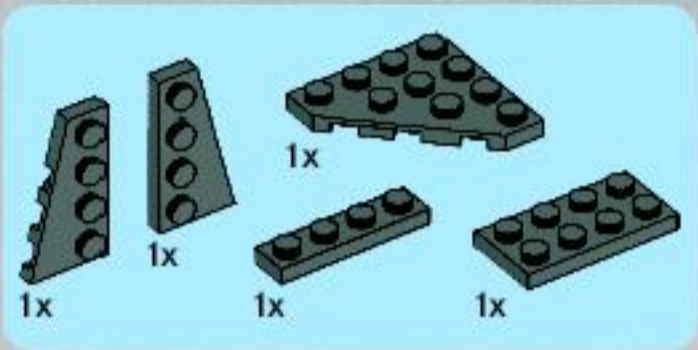
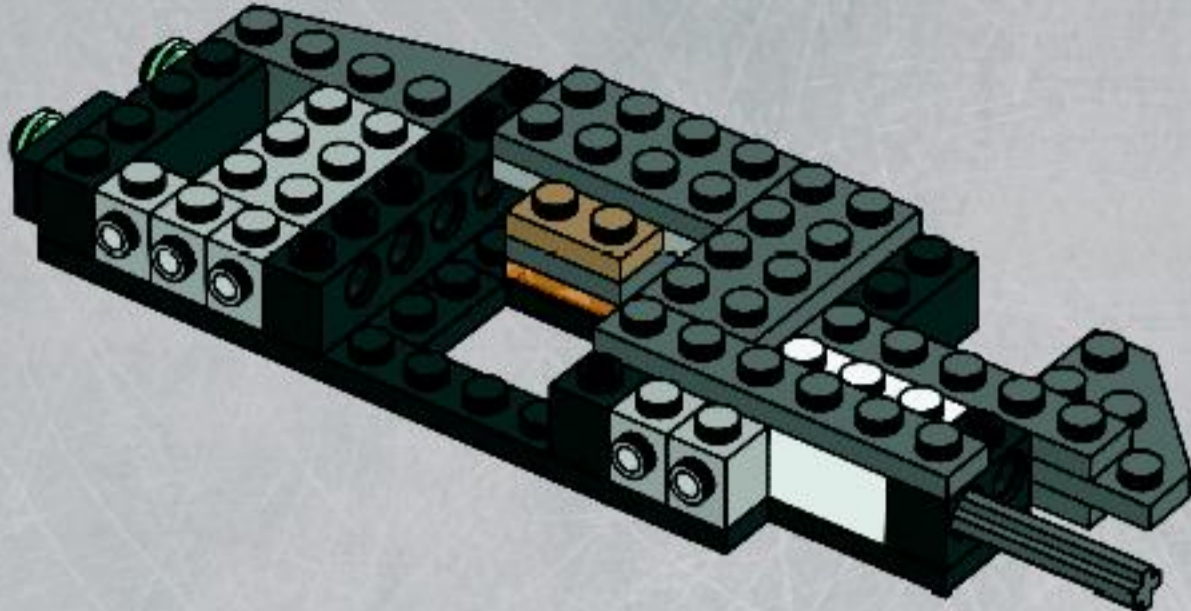

13

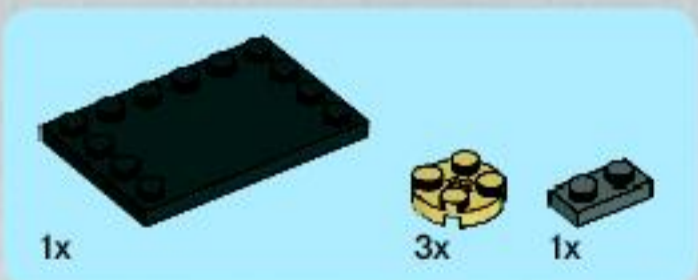
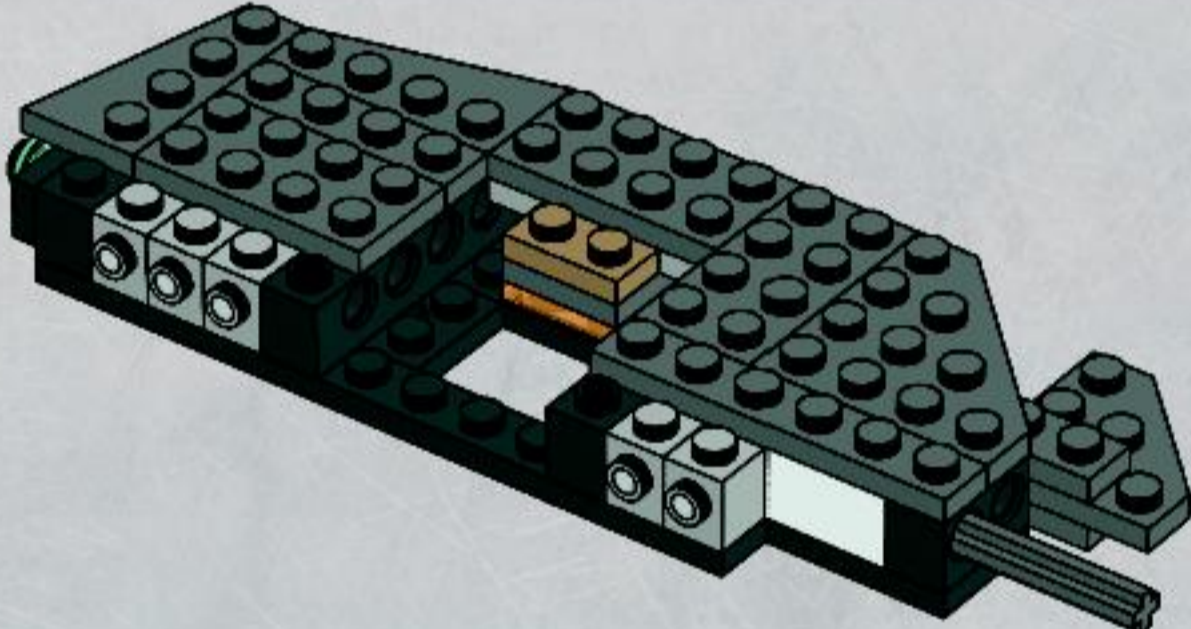

14

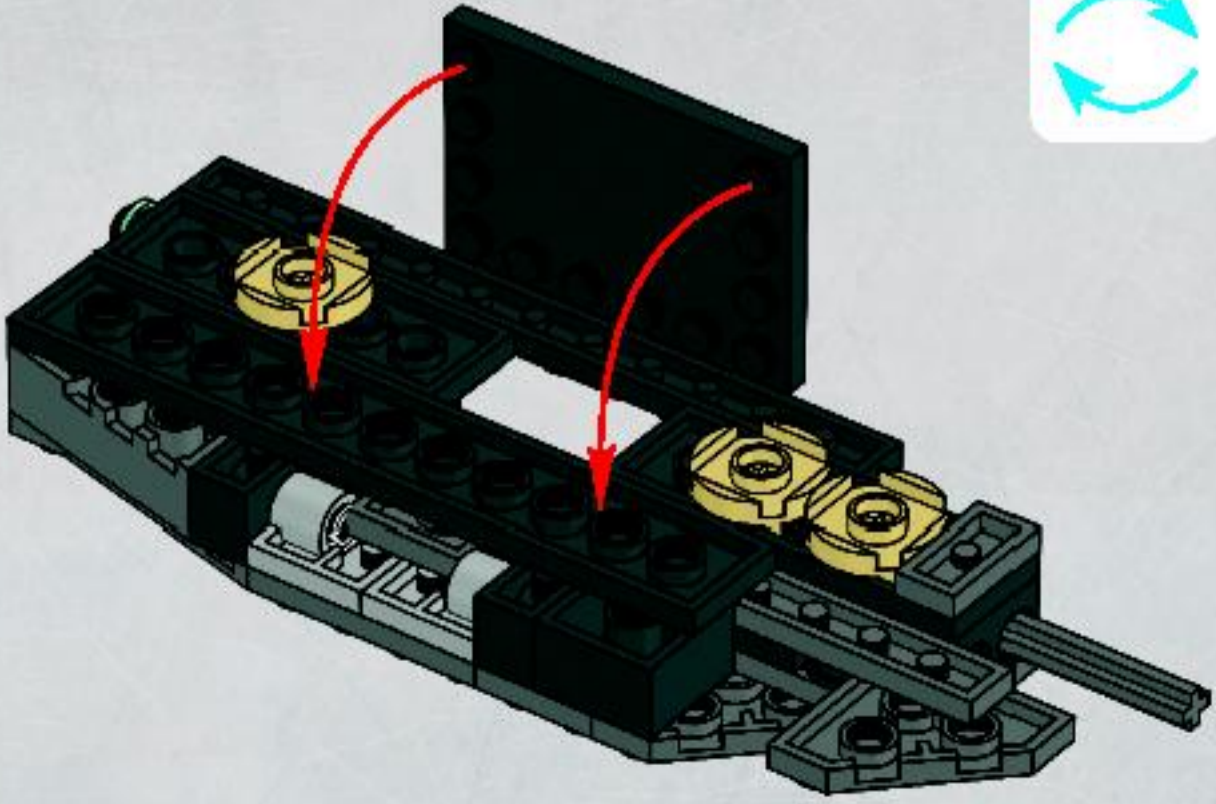

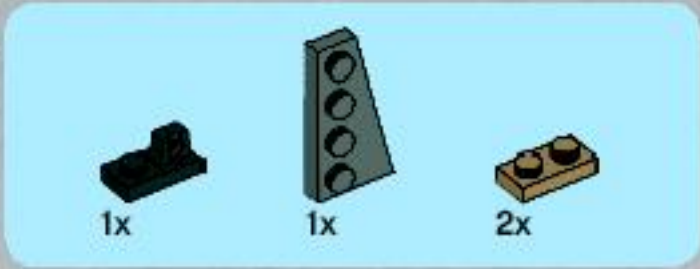

15

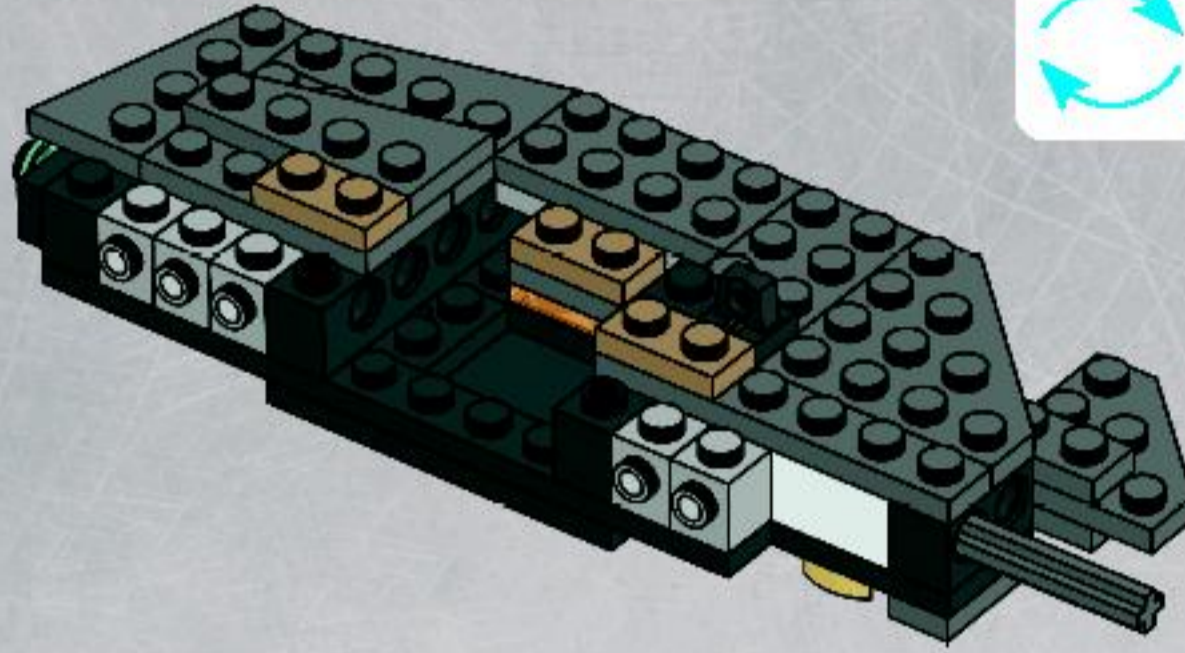

16

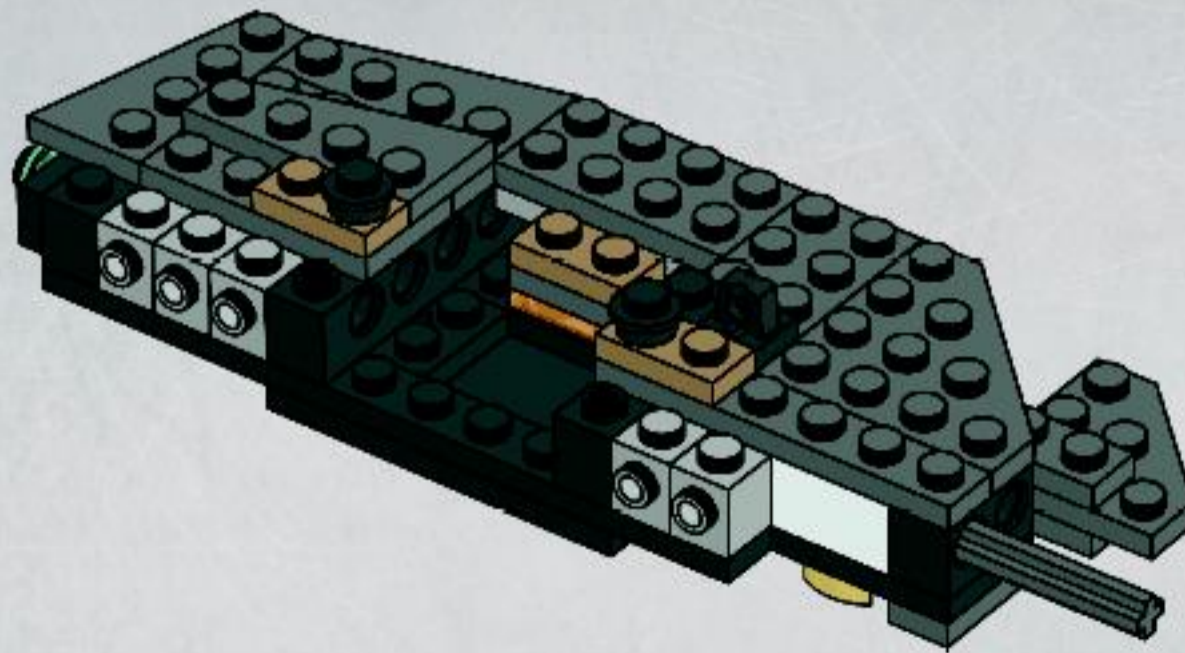

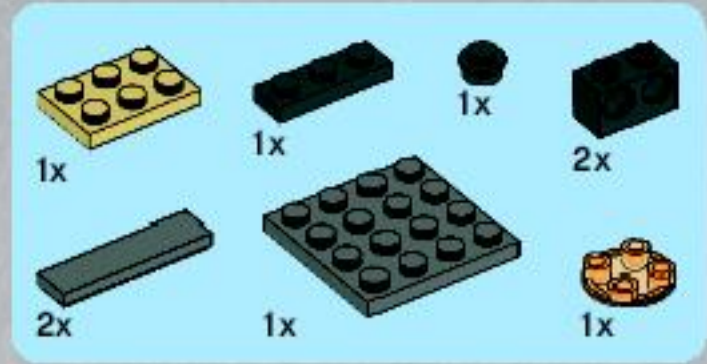

17

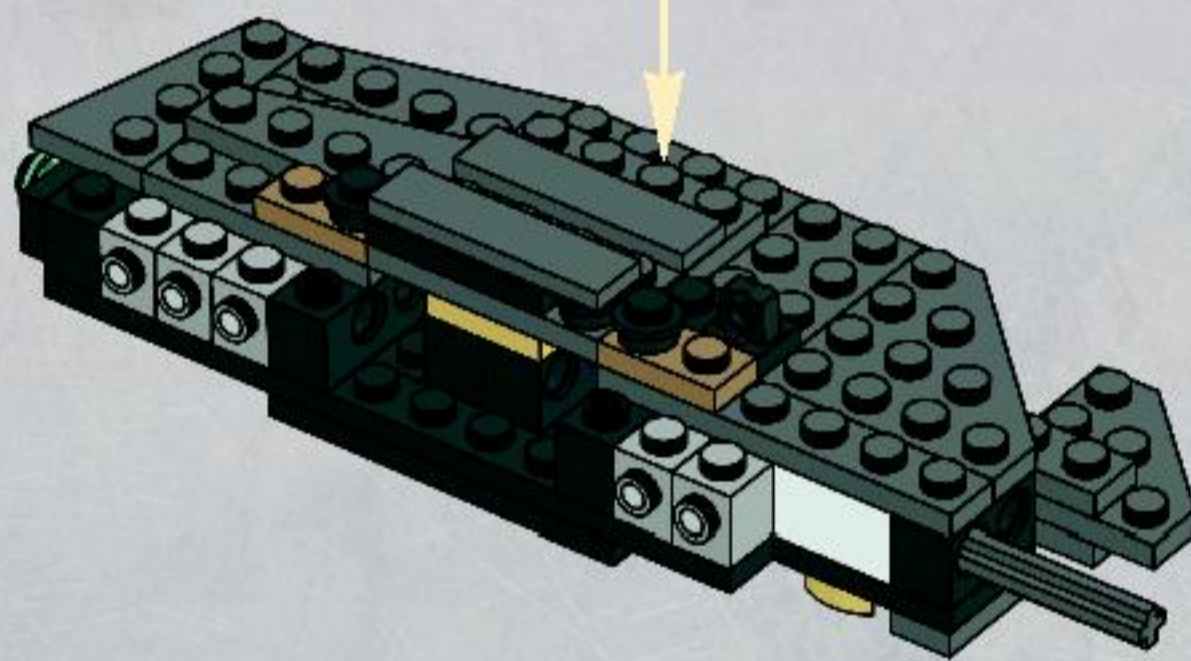
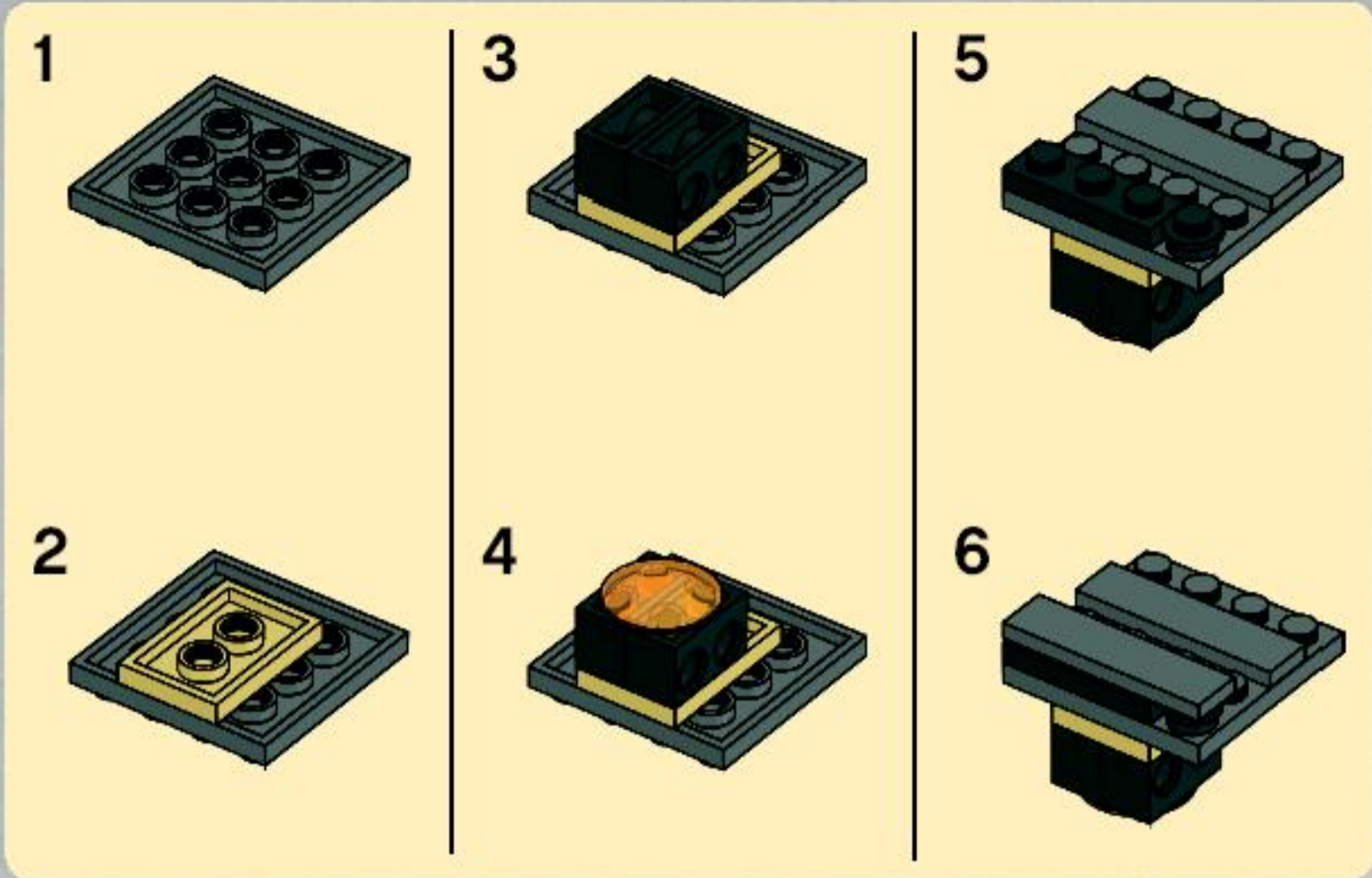

18

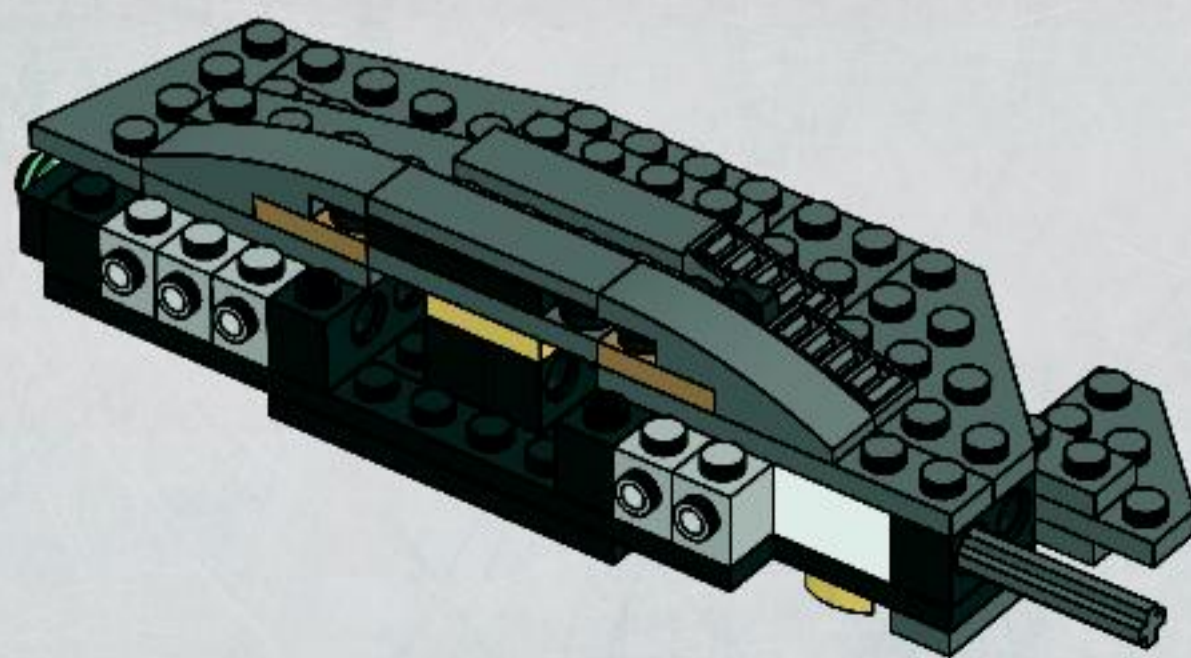

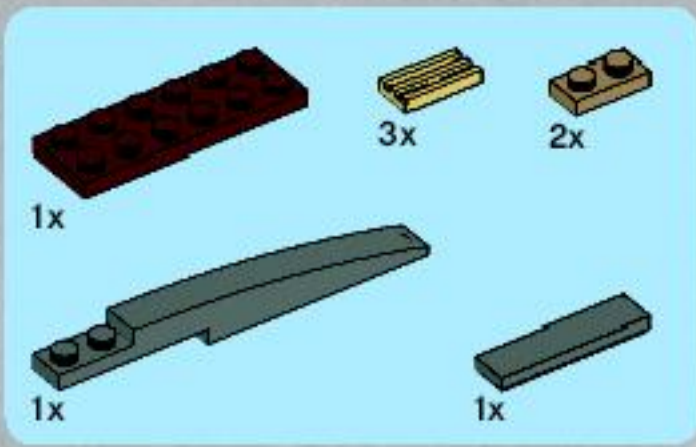

19

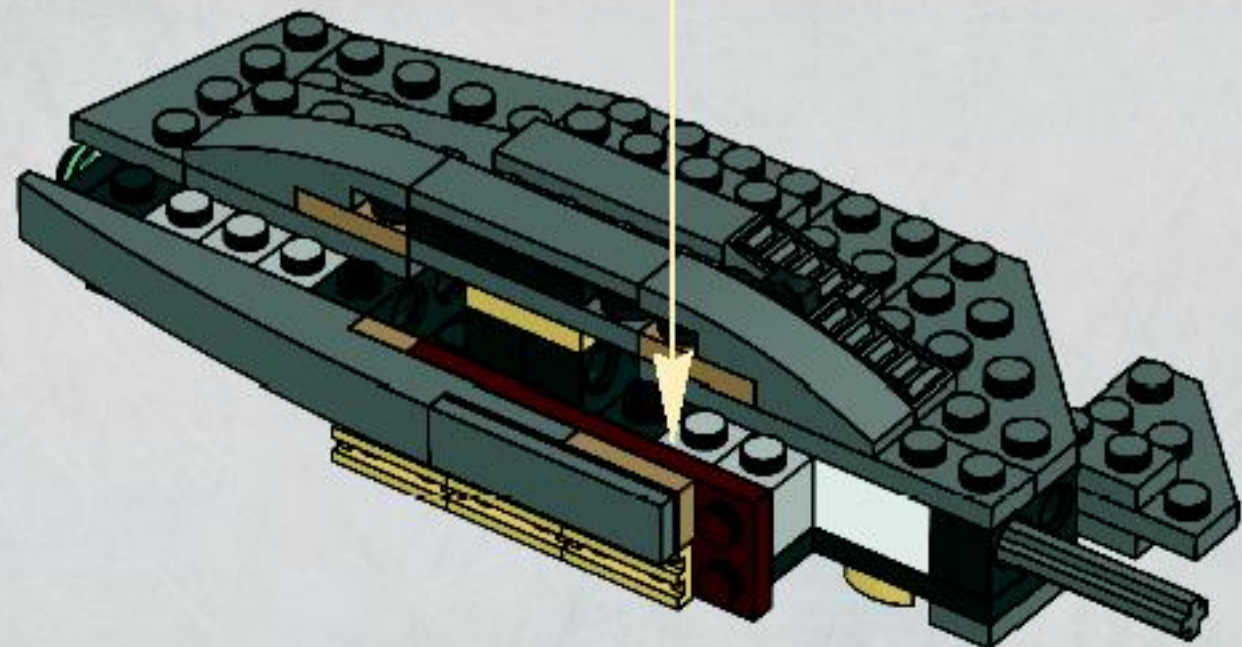
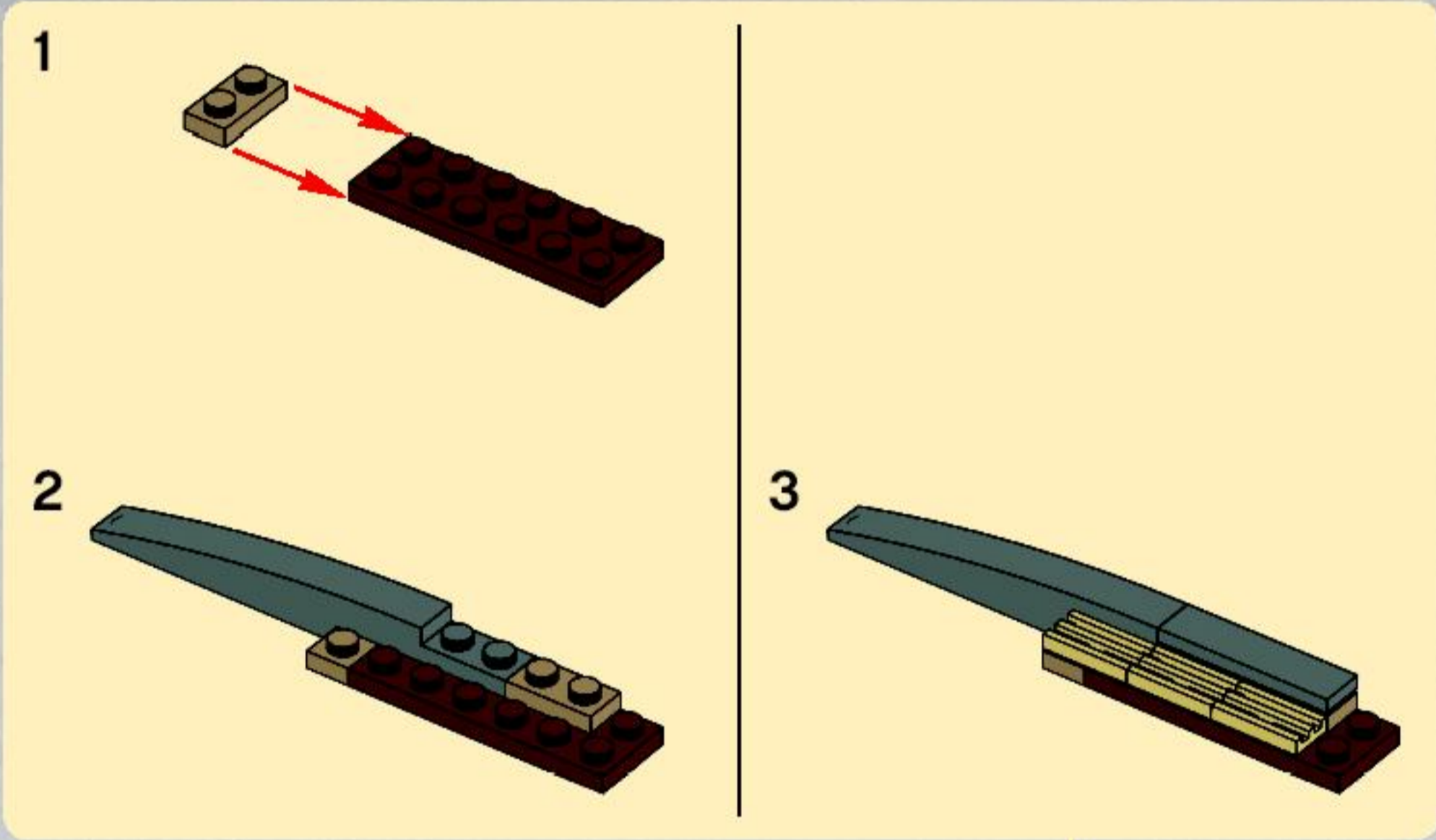



20

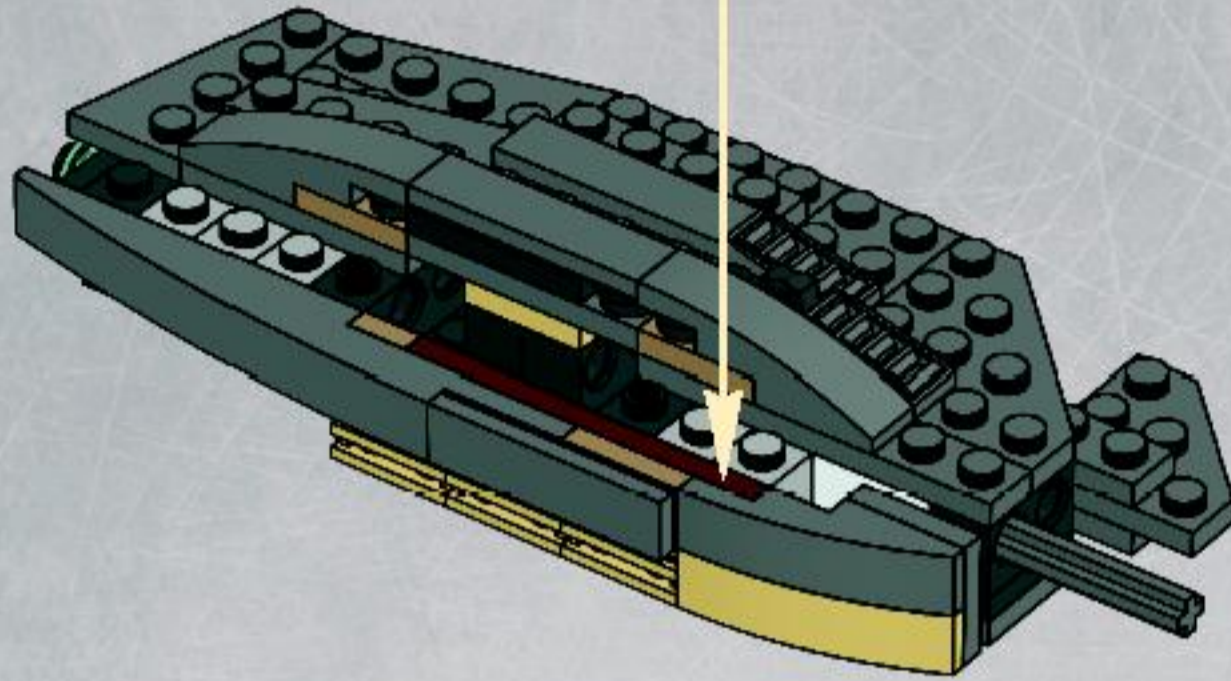
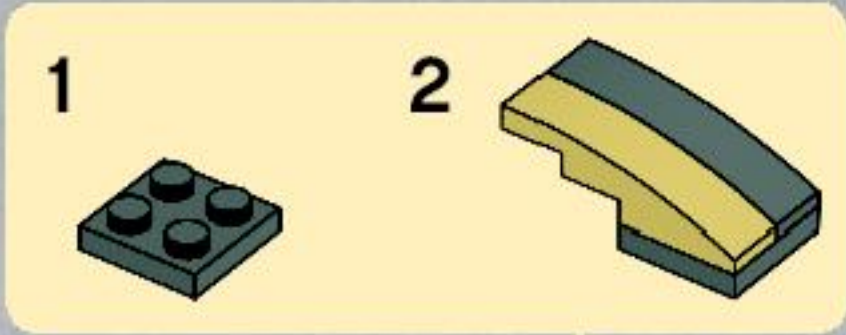

21

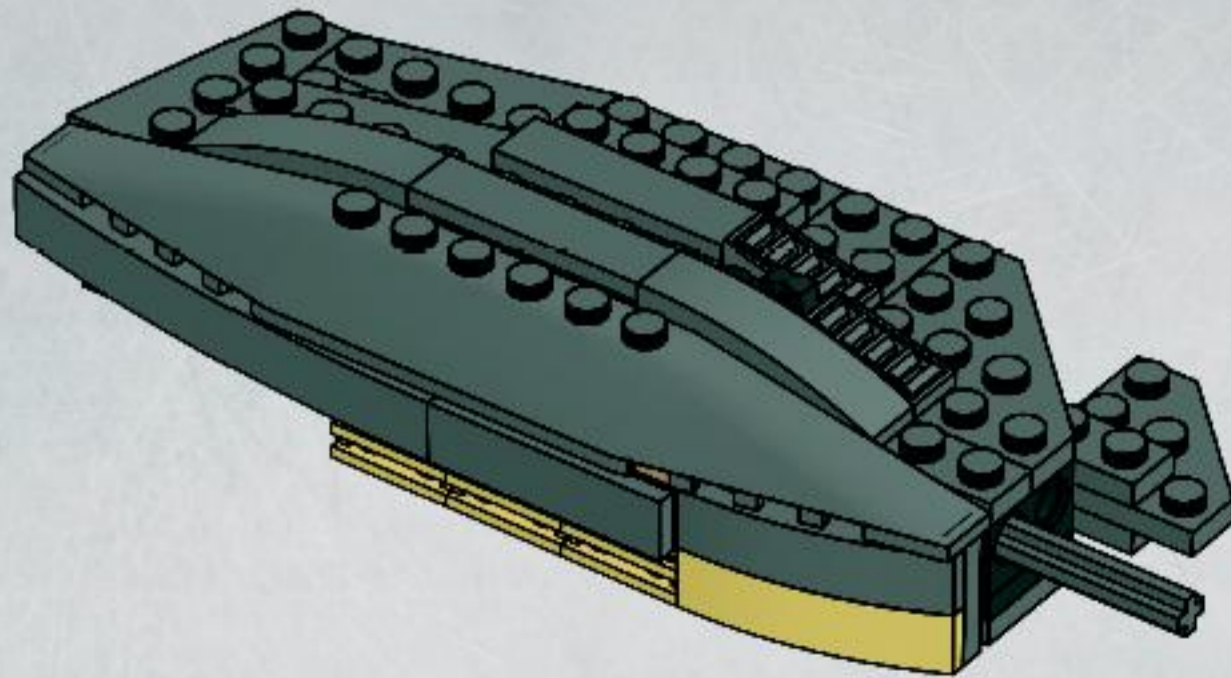



1x

22

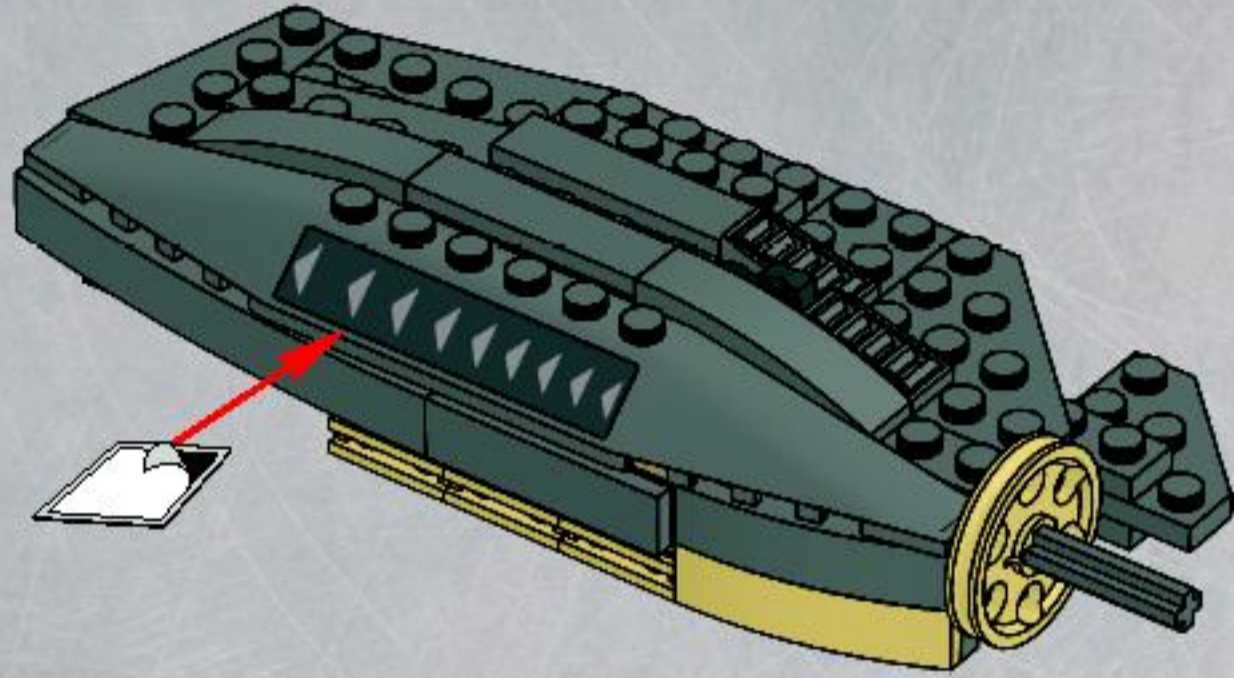

1x



1x

23

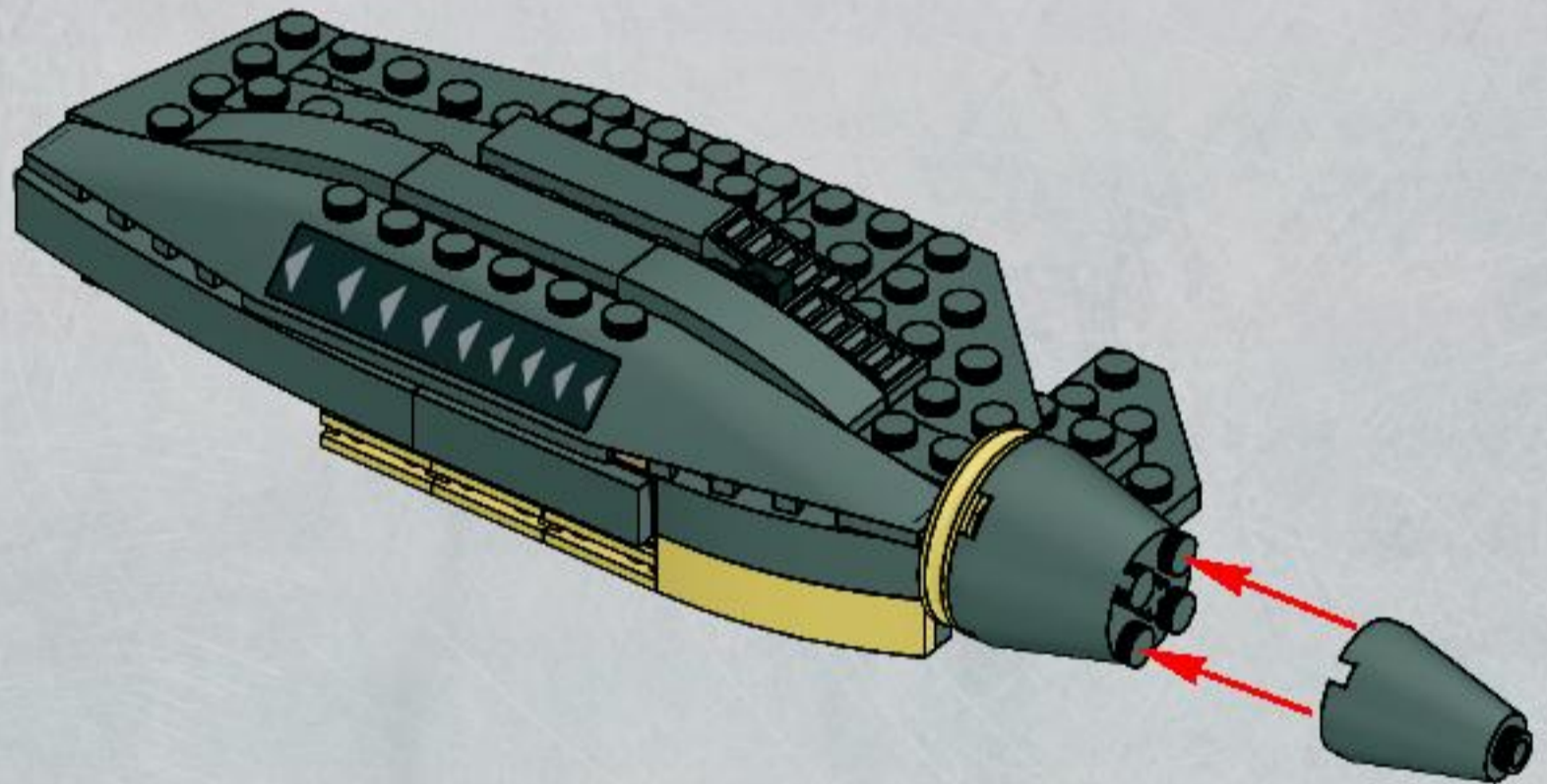

3x

24

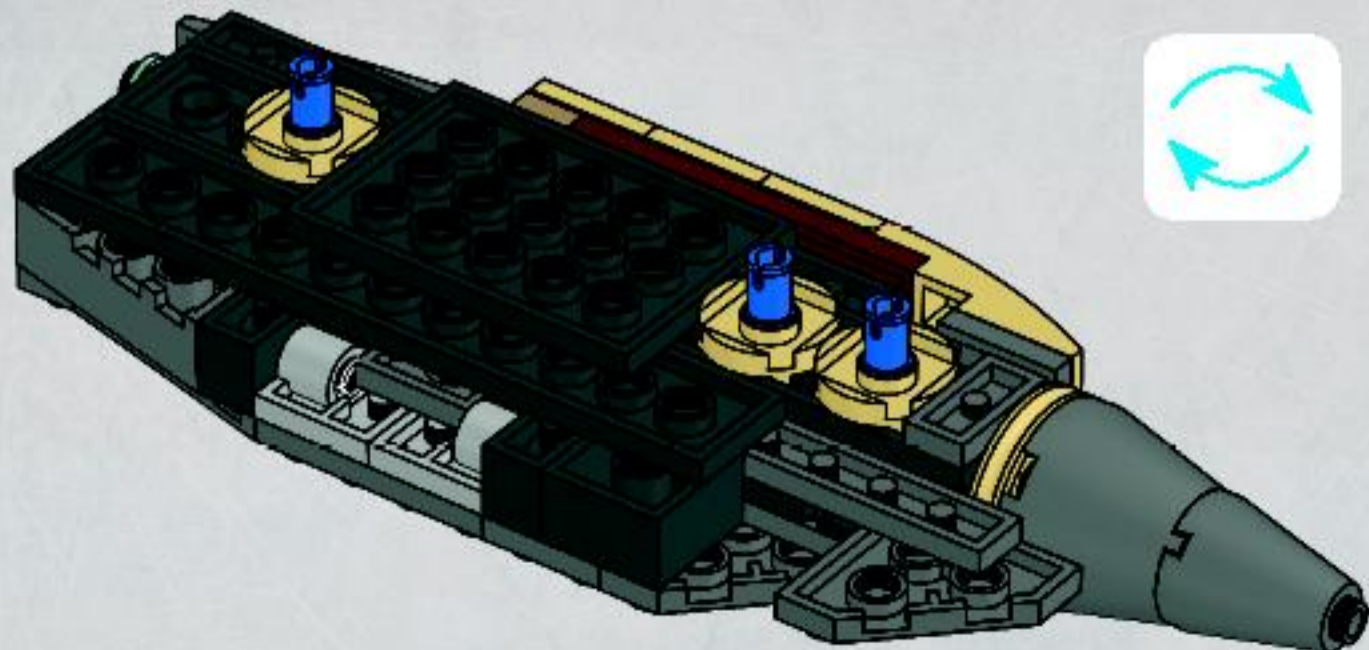



4x



1x



4x

25

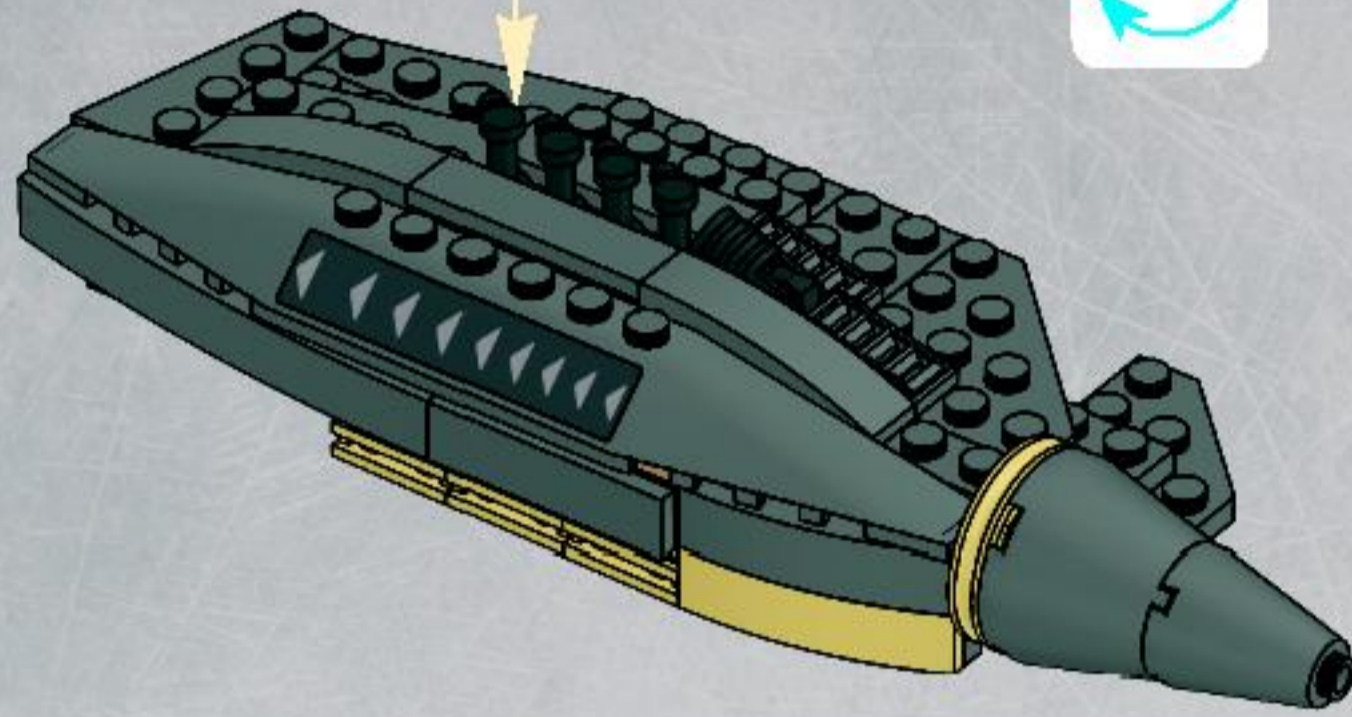

44

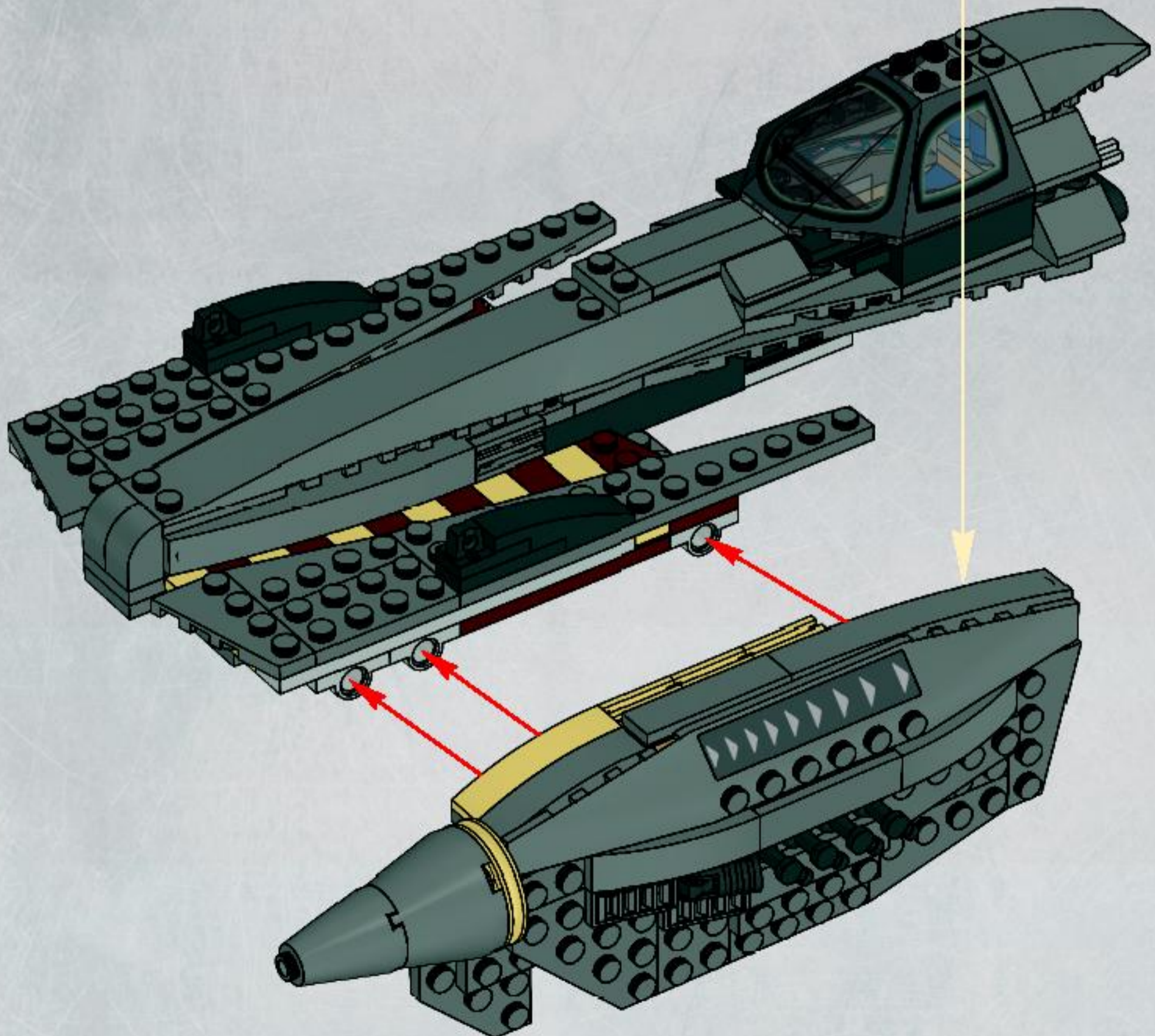

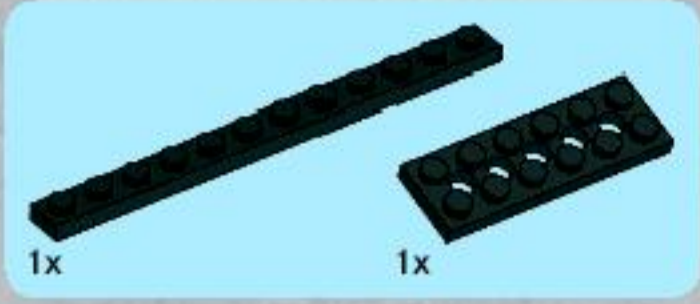
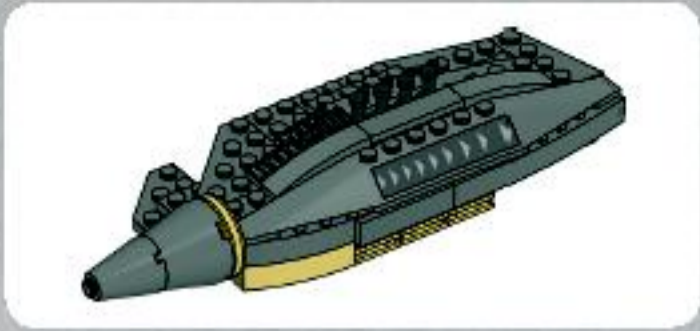

1

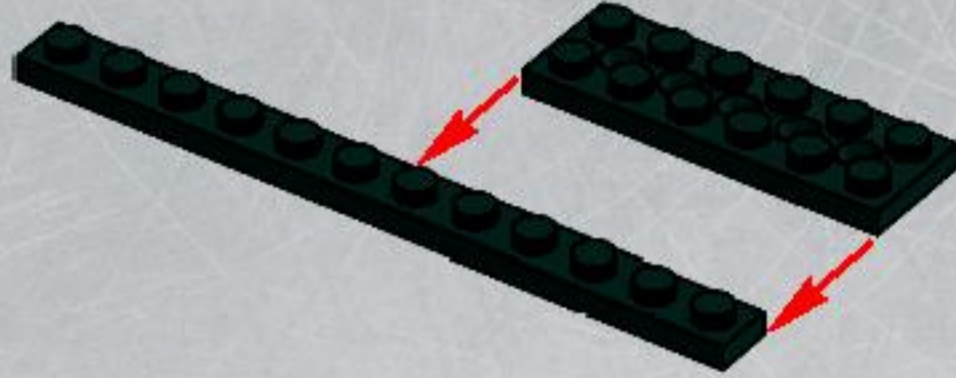

2



3





3x

4

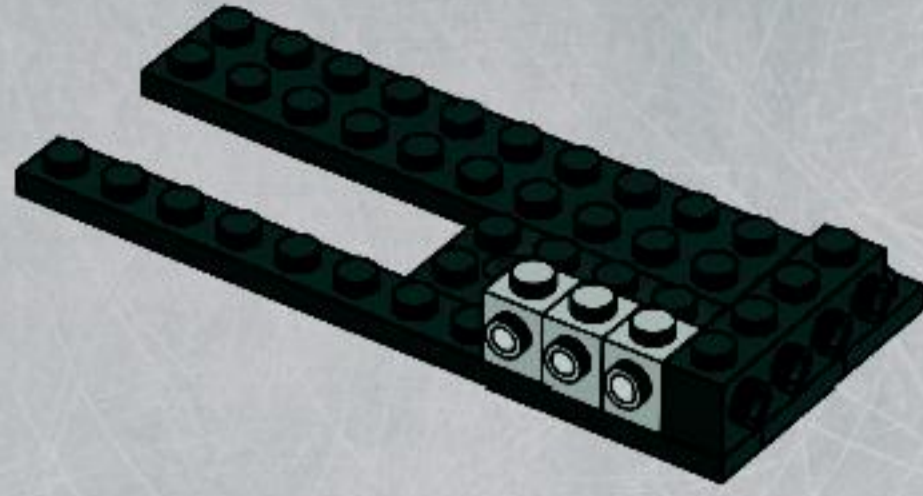

1x

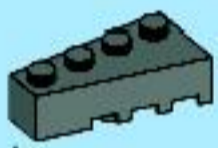

1x

5

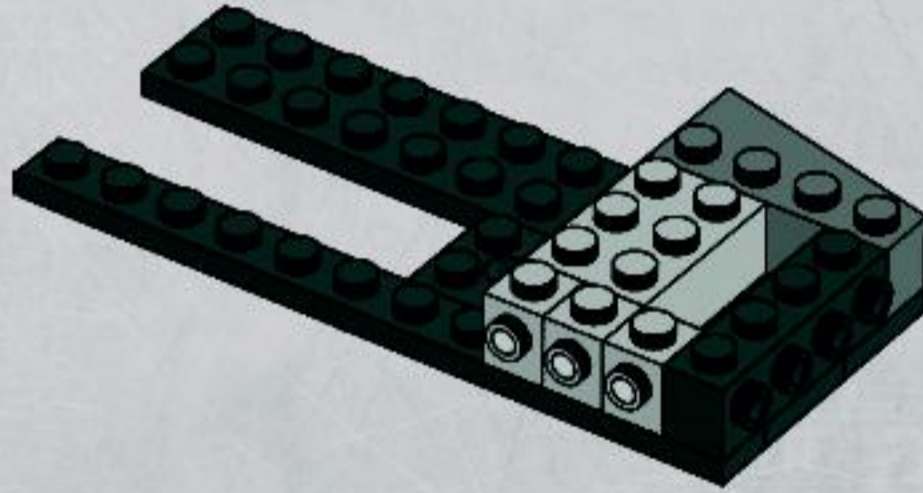

1x



2x



1x

6

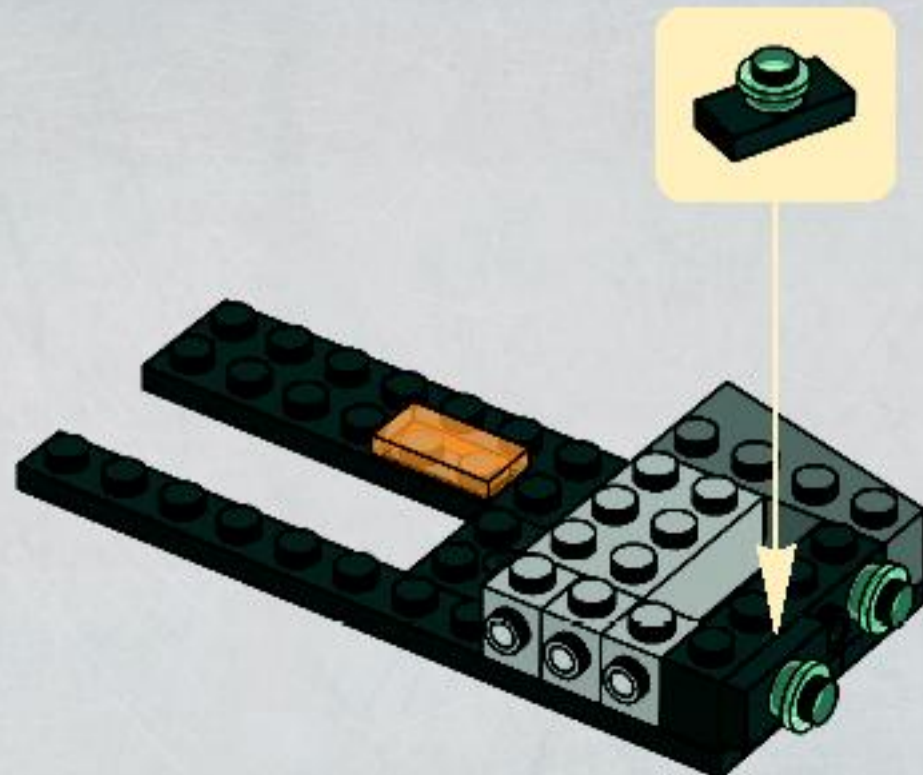

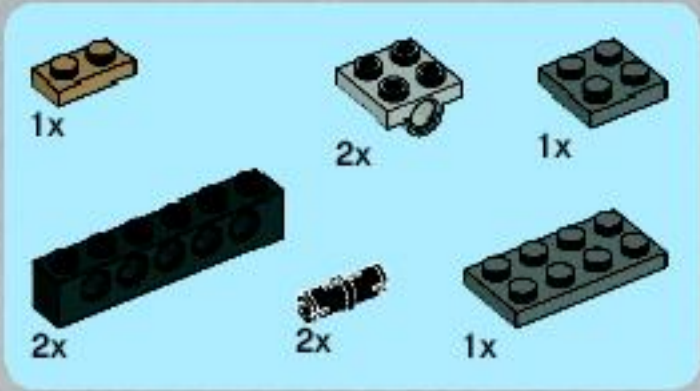

7

1



2

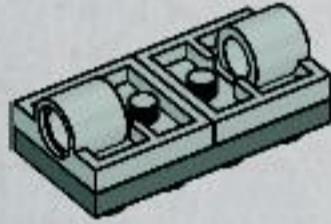

3

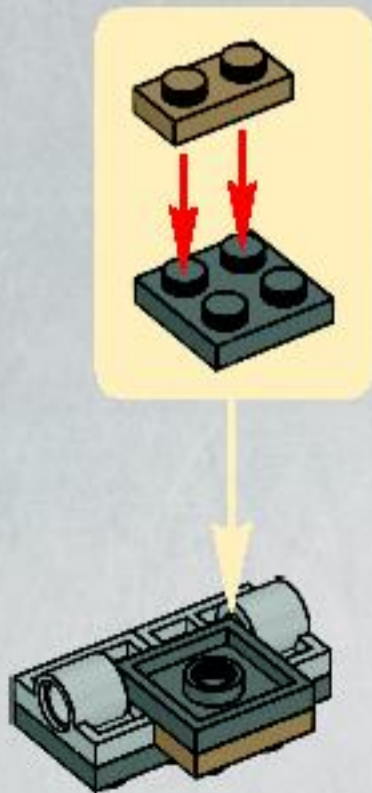

4

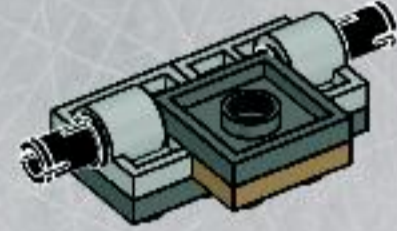

5

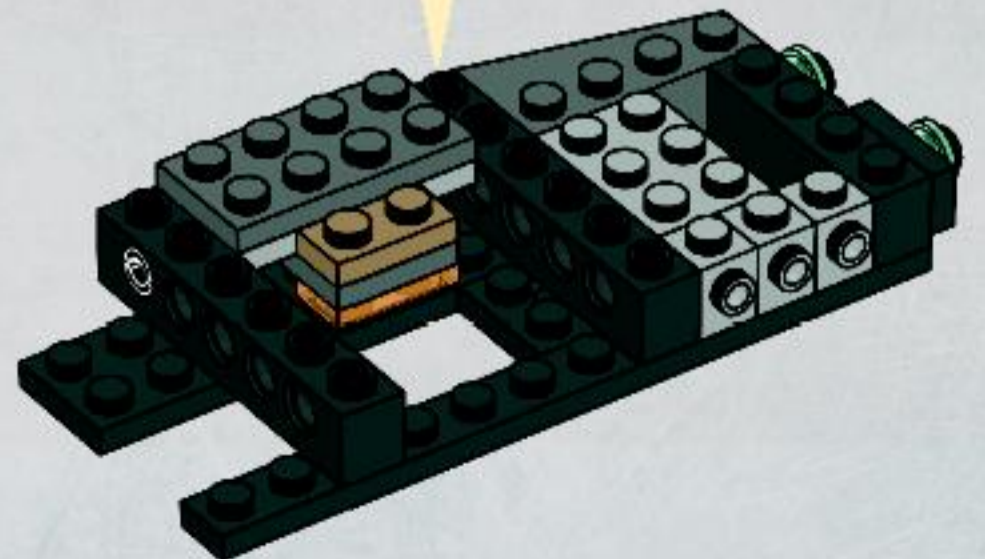
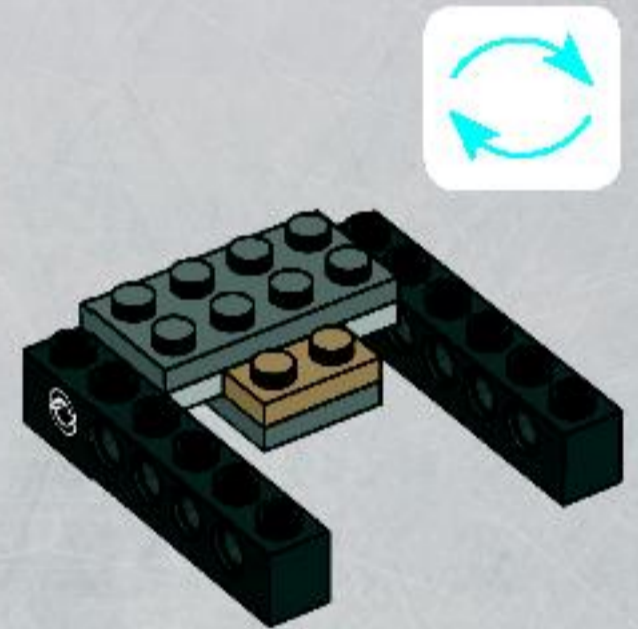



2x

8

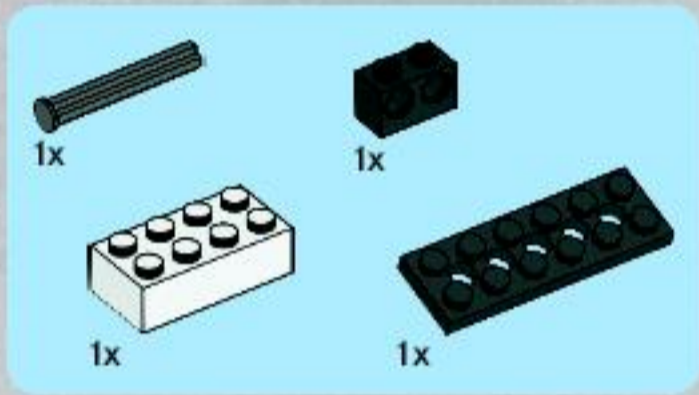
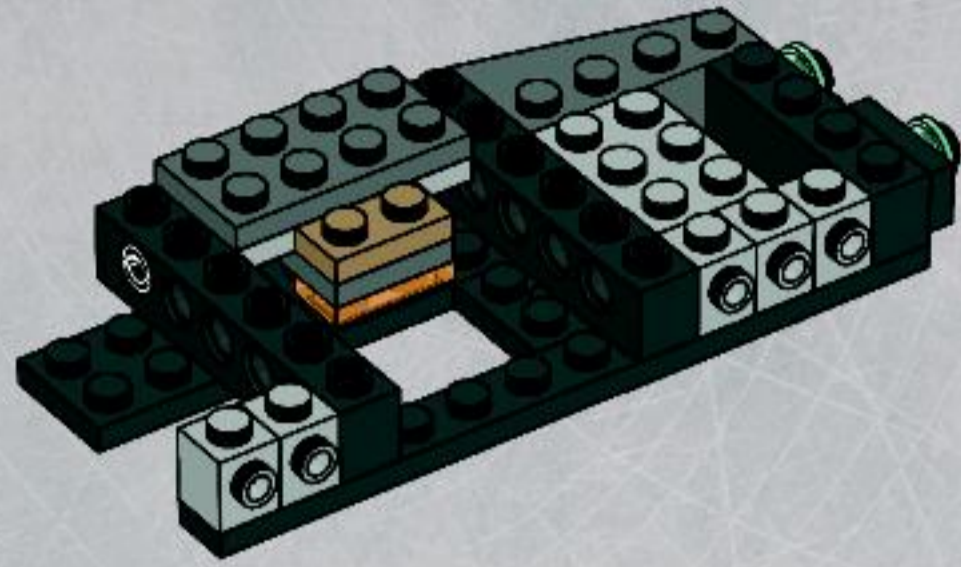

9

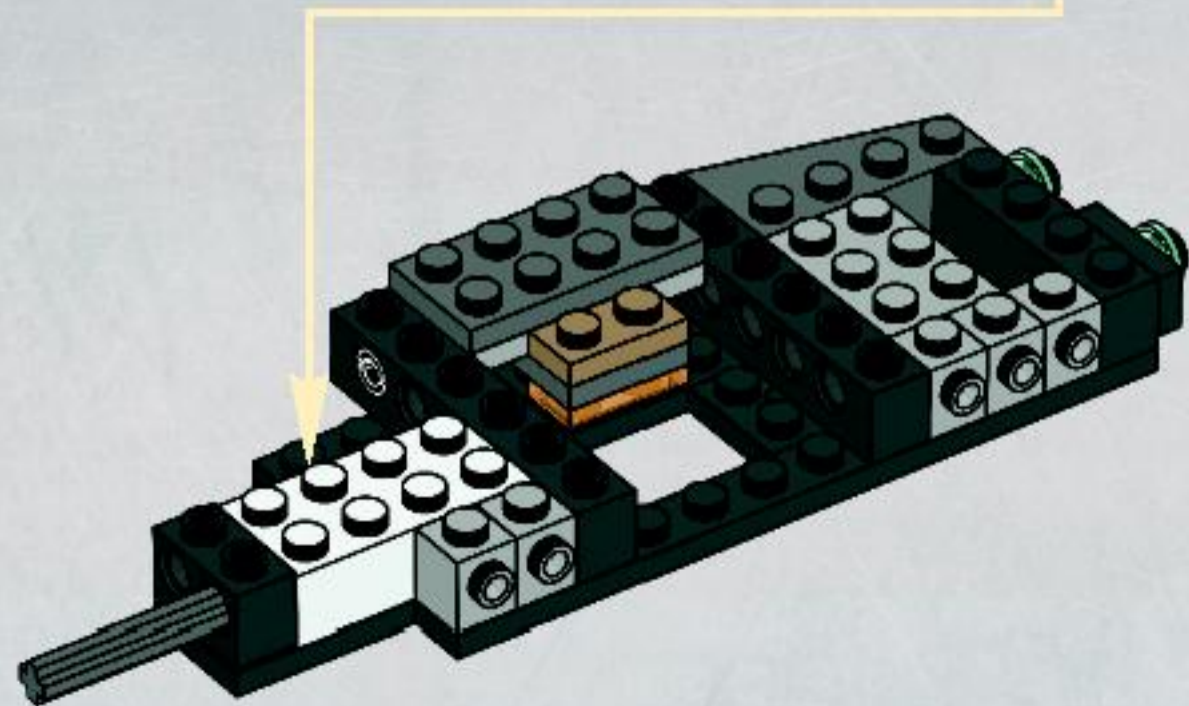
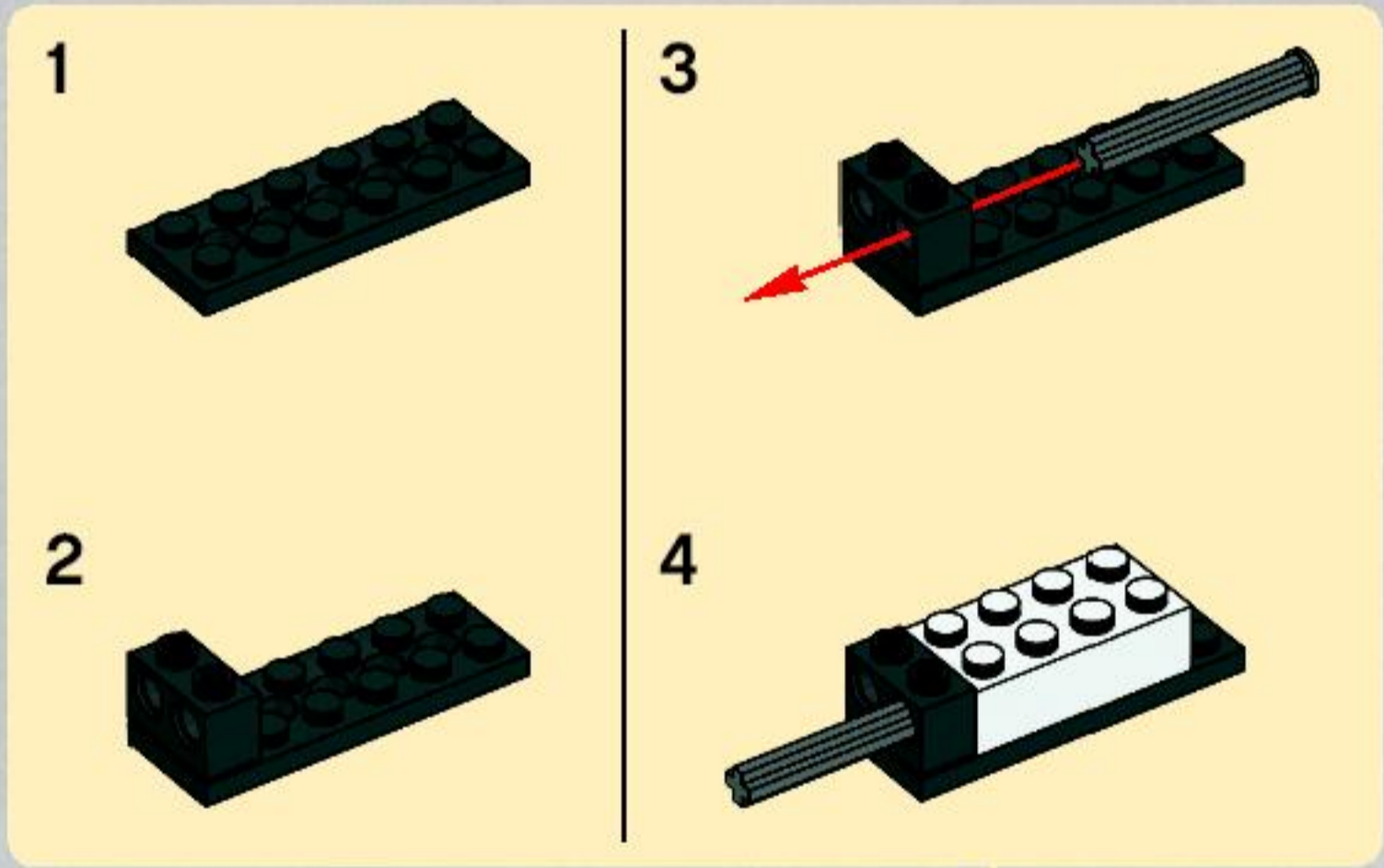

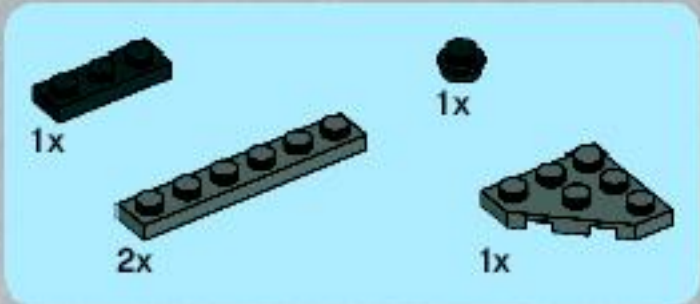

10

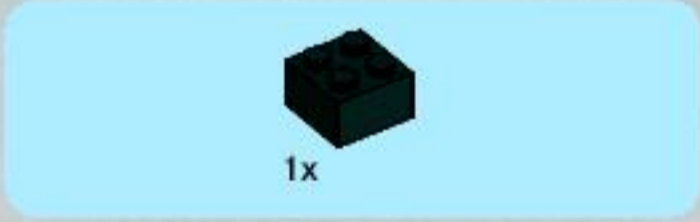
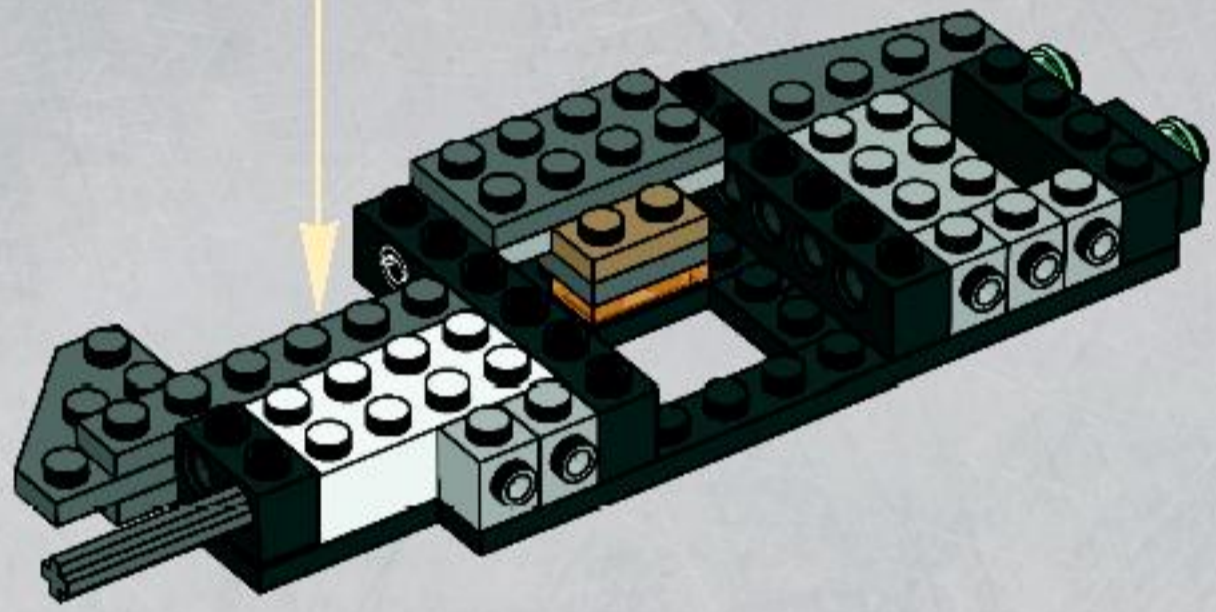
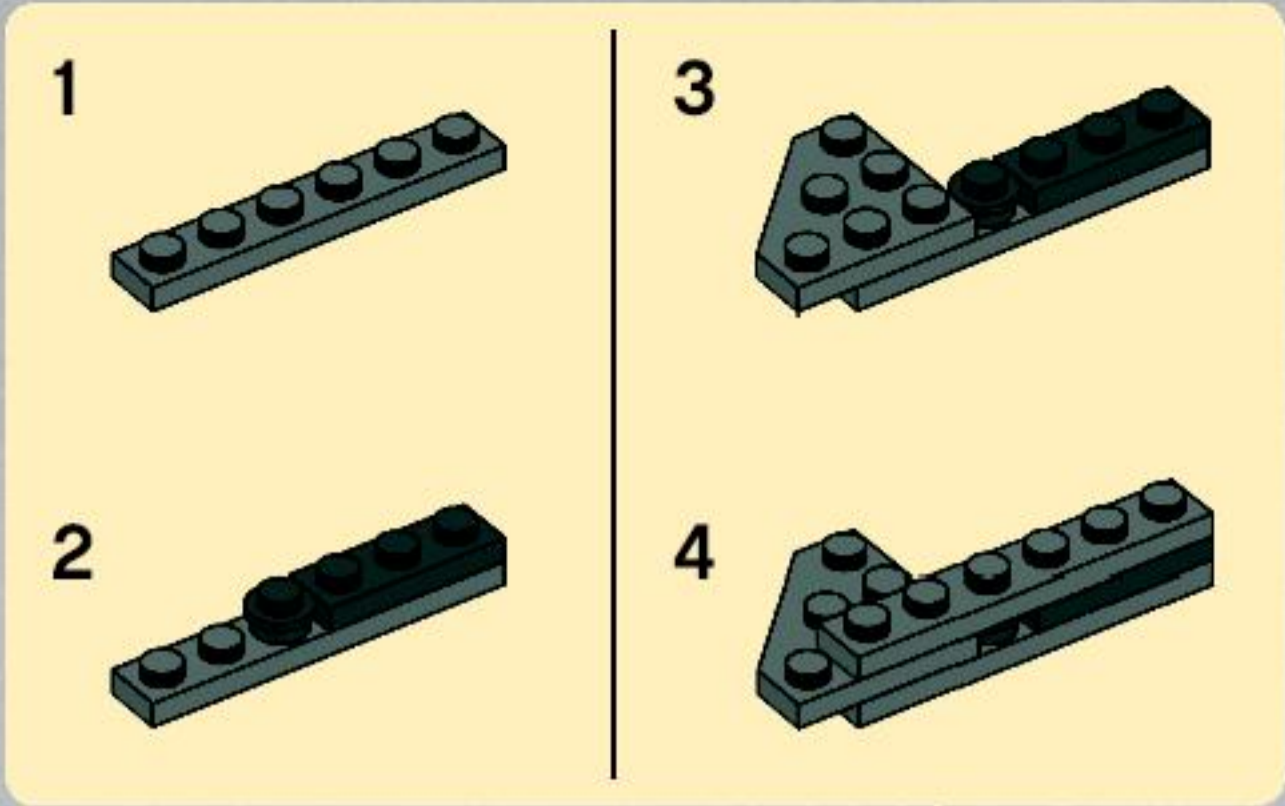

11

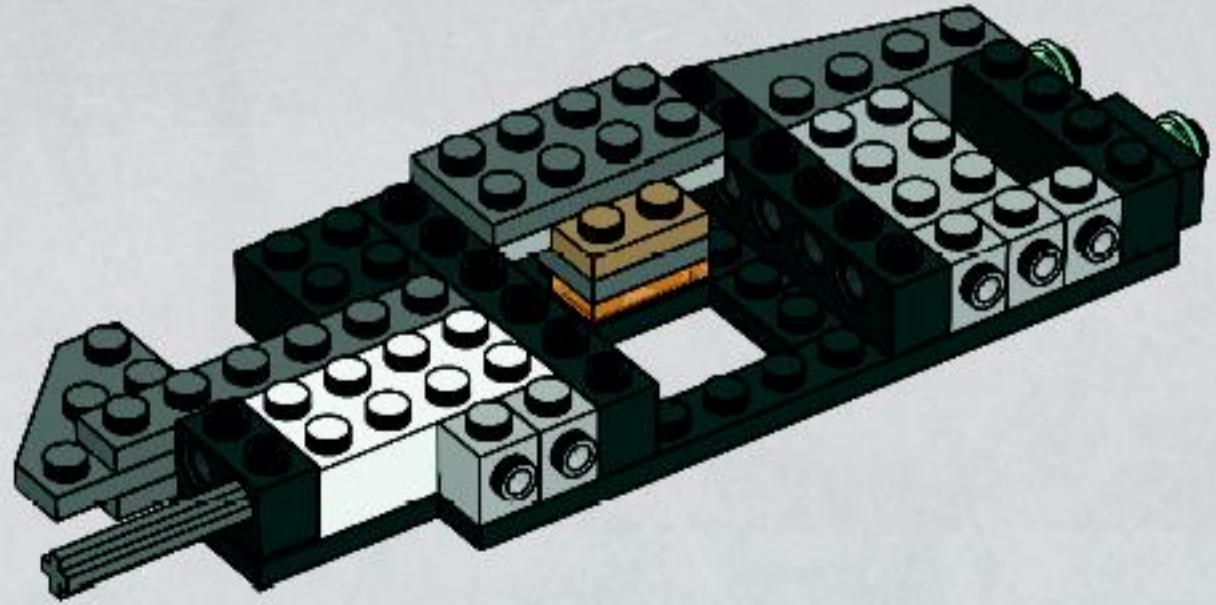

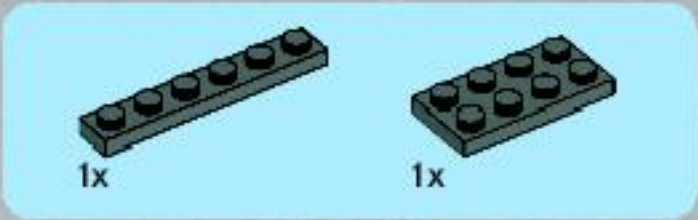

12

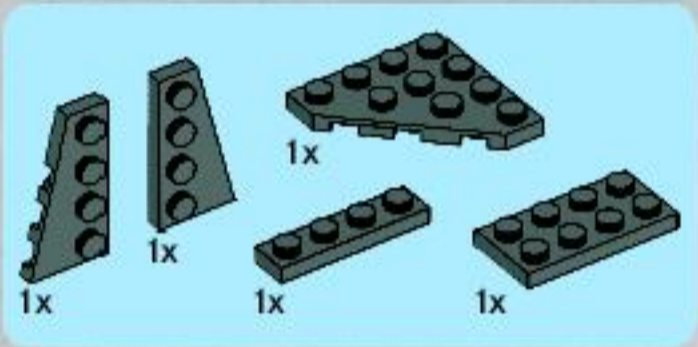
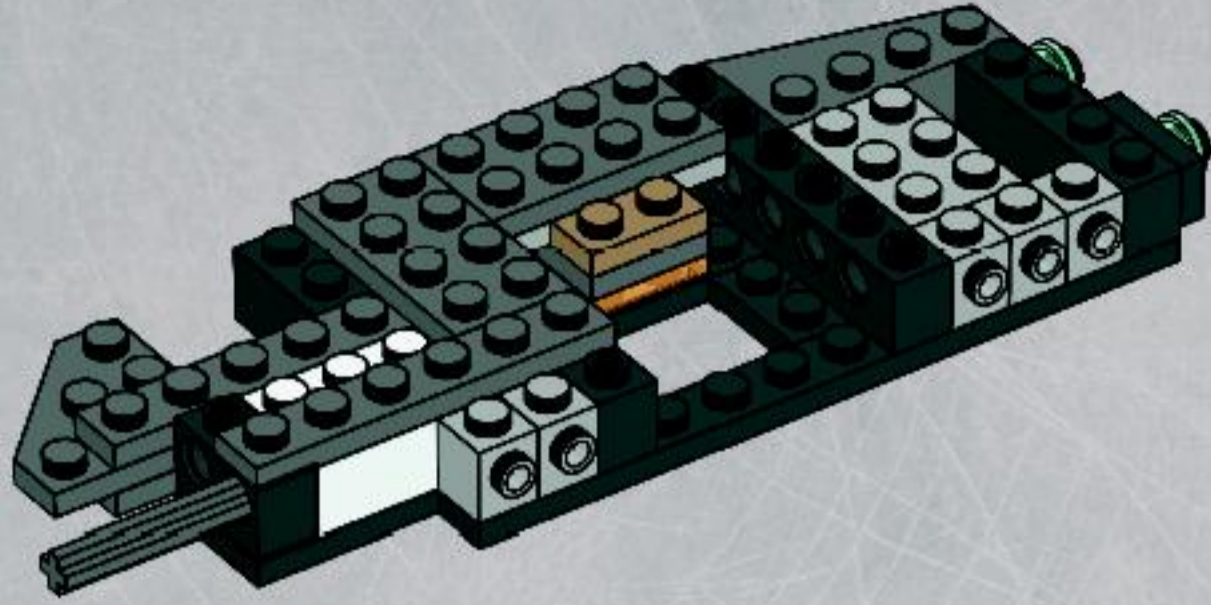

13

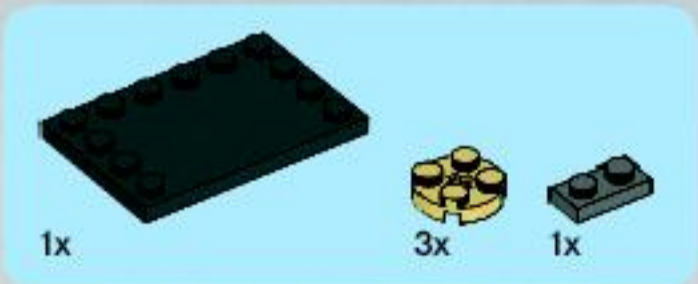
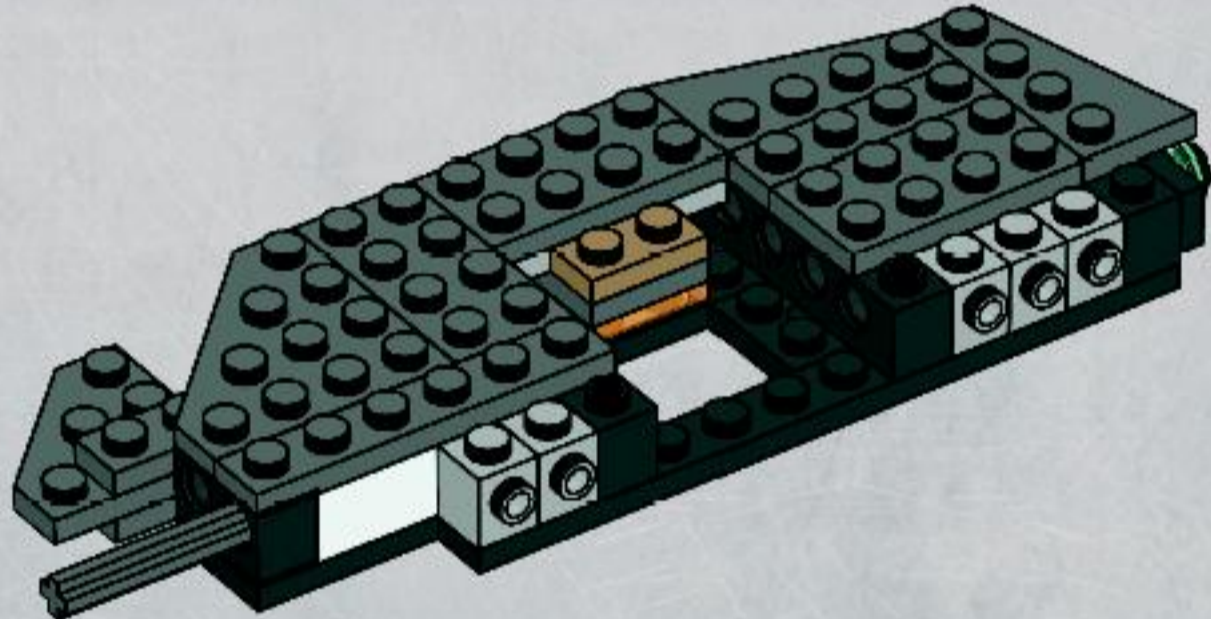

14

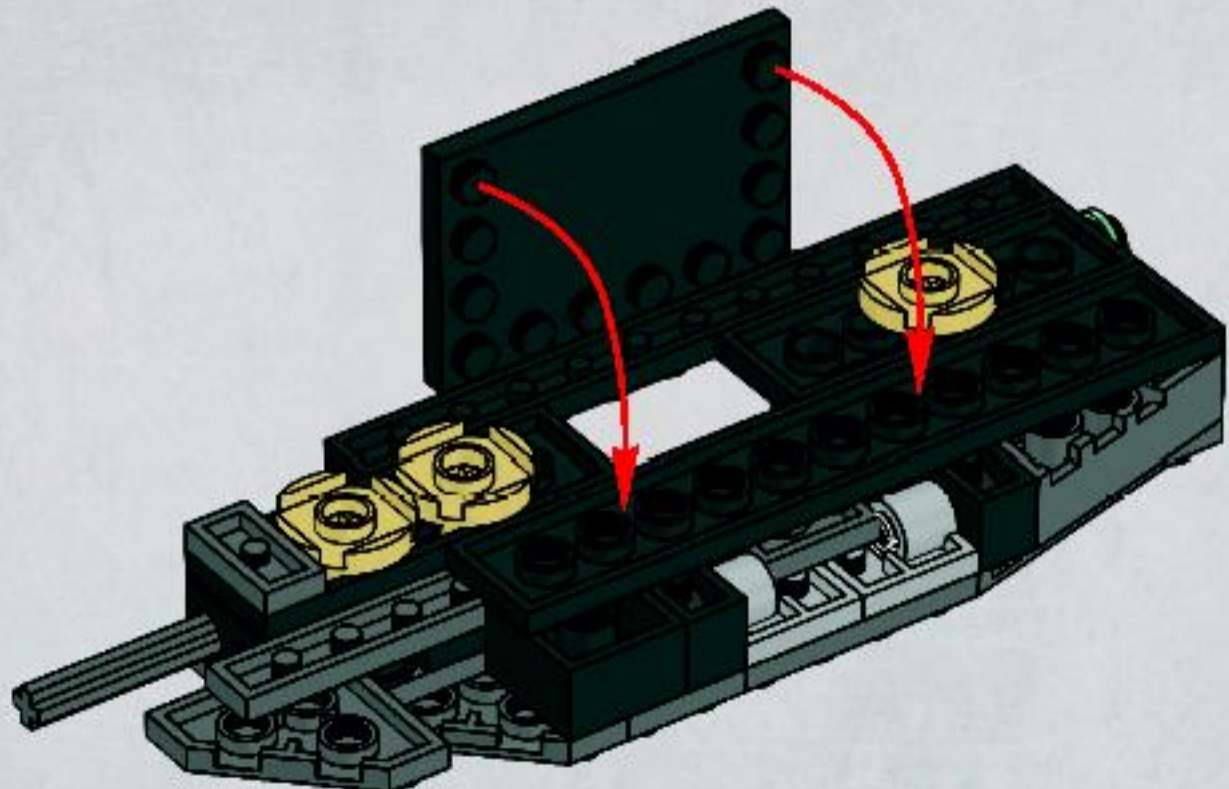

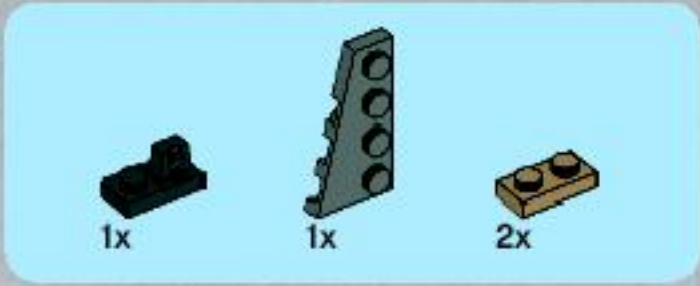

15

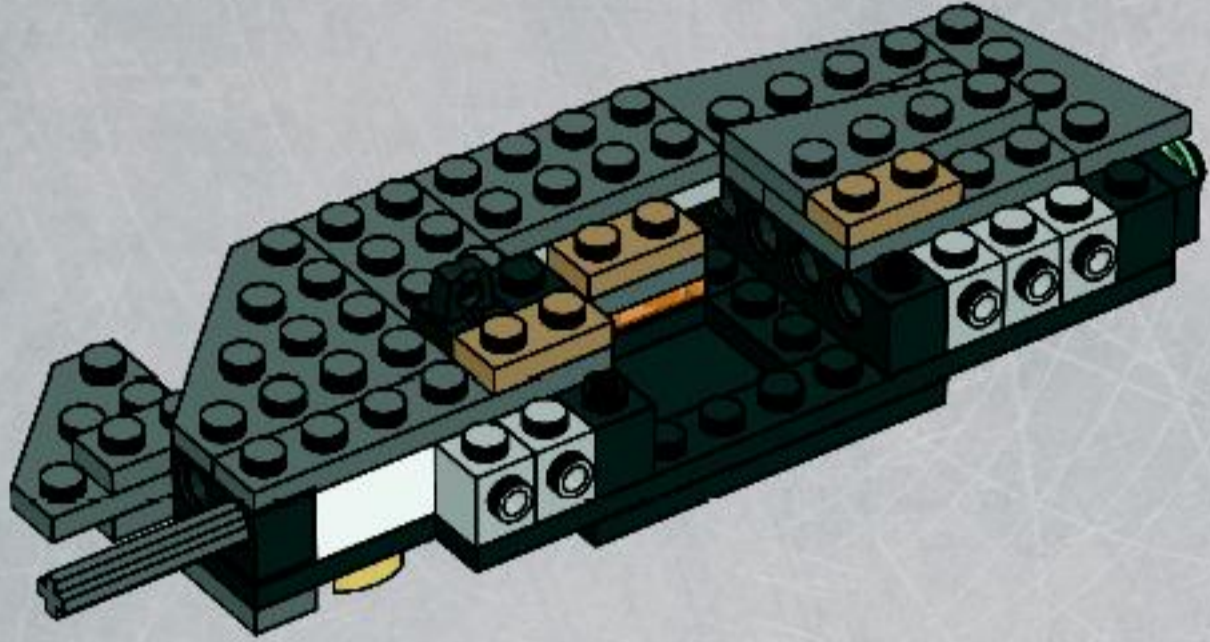

16

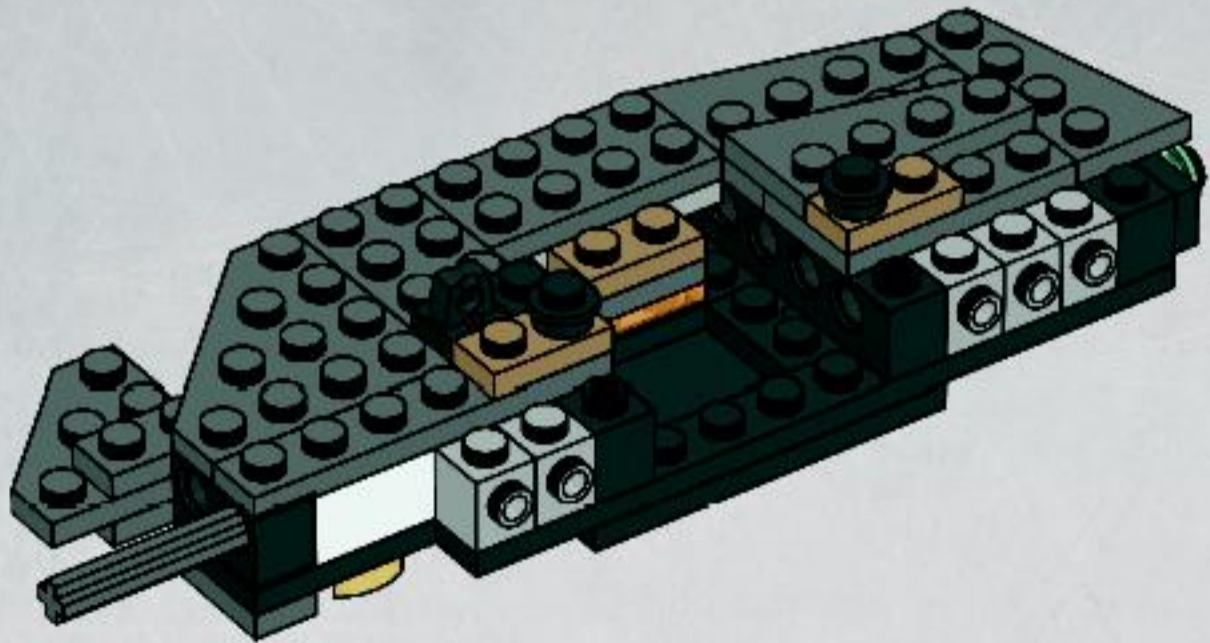

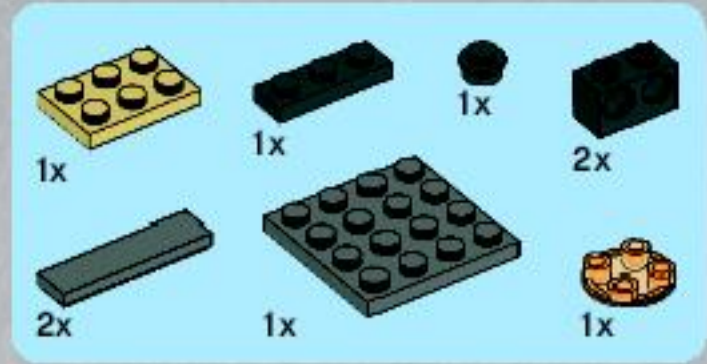

17

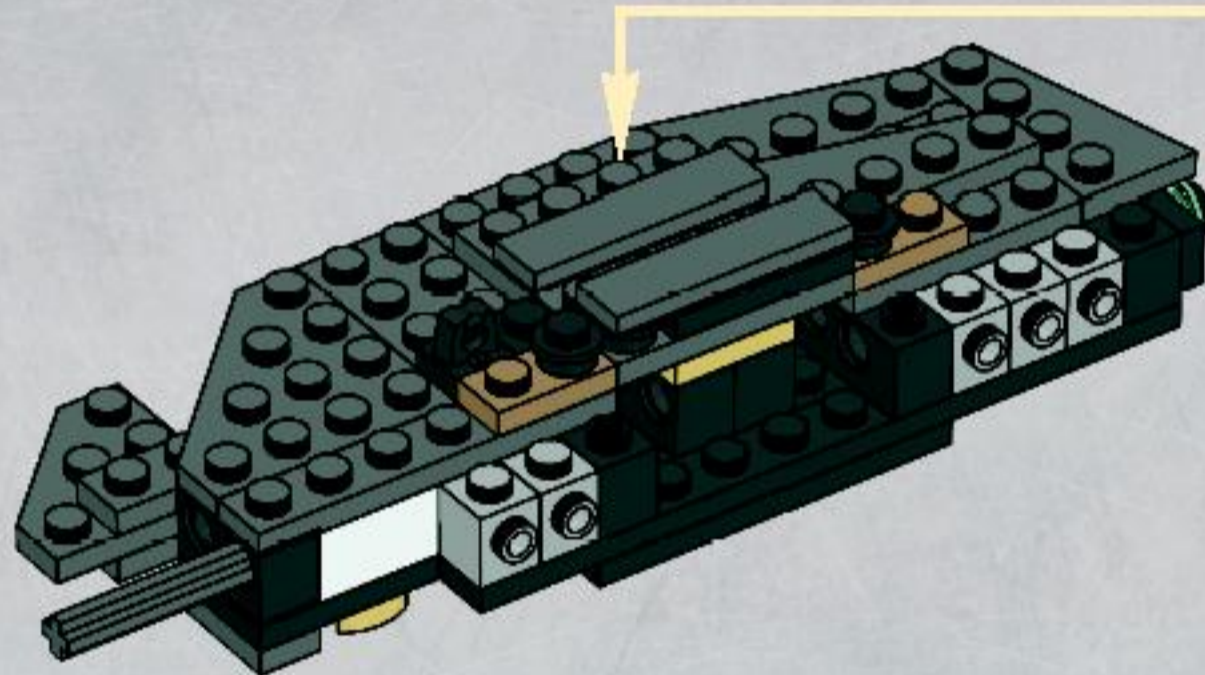
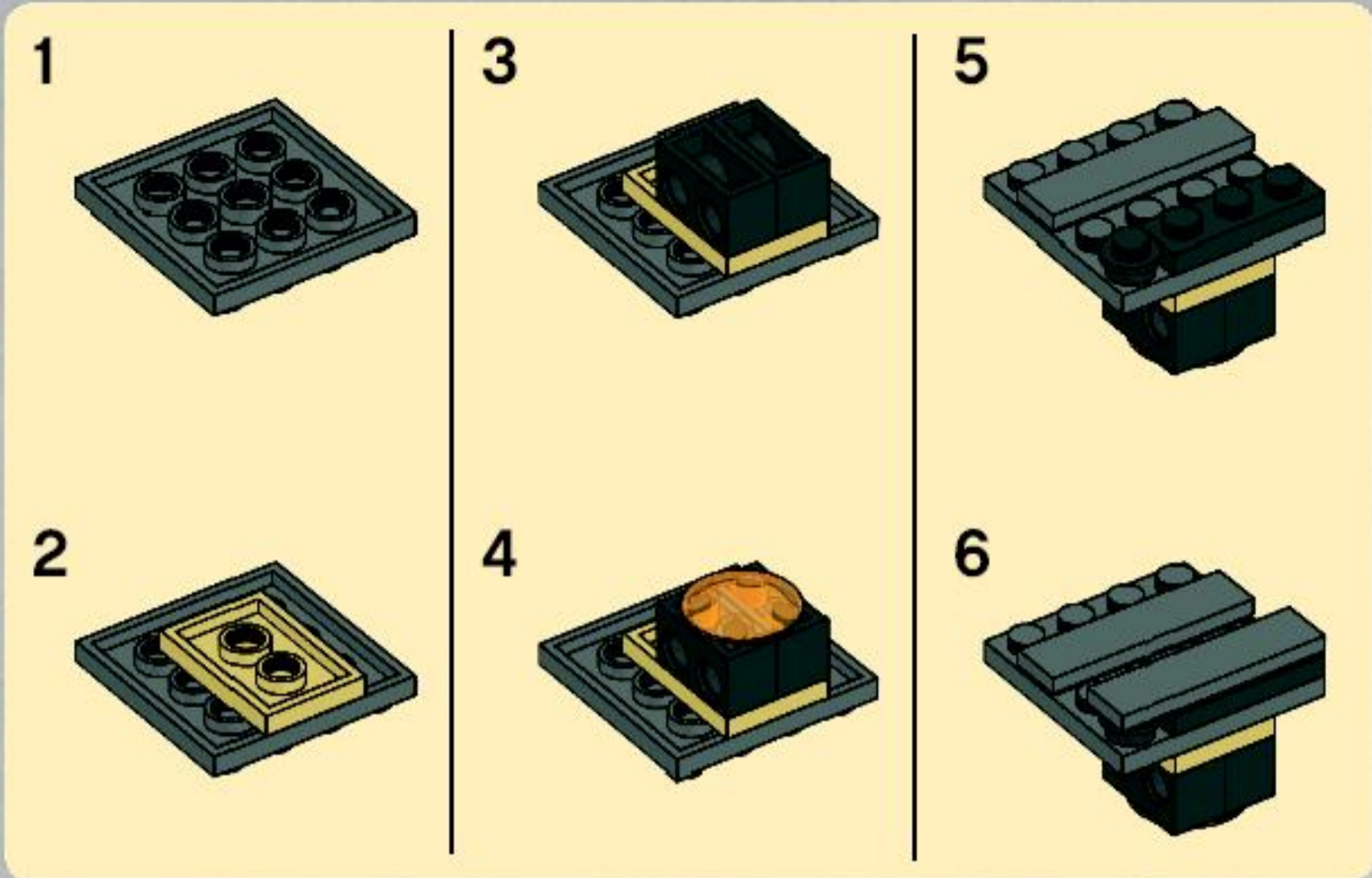

18

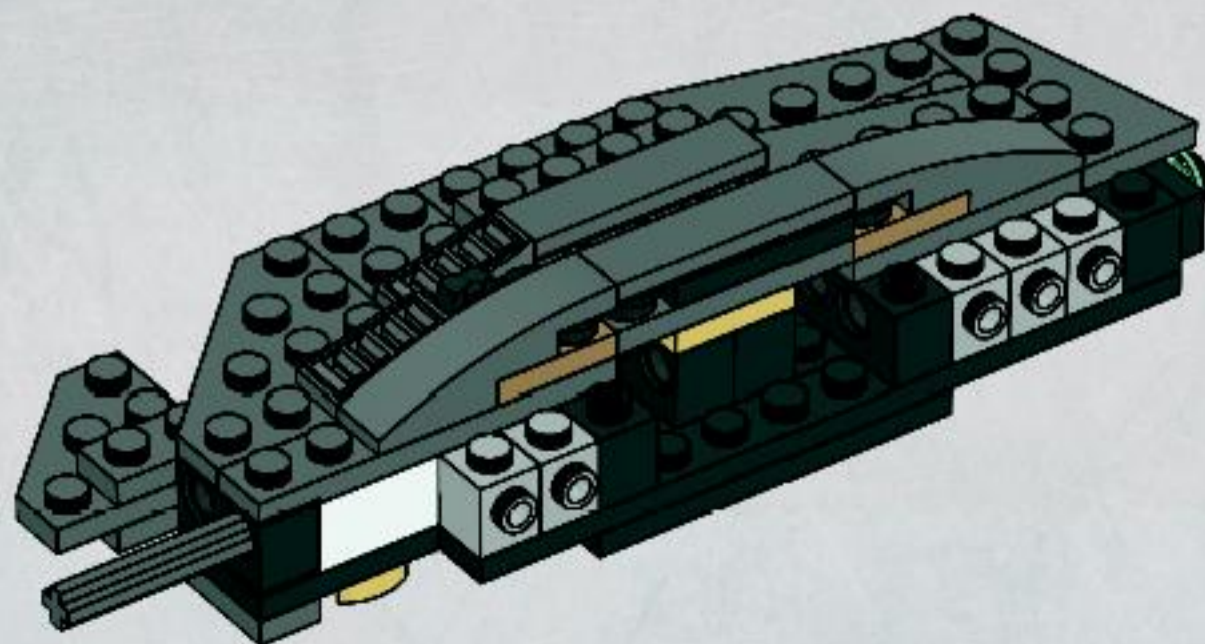

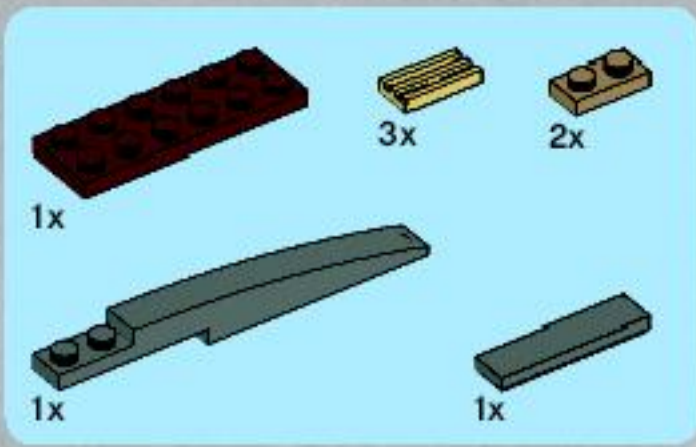

19

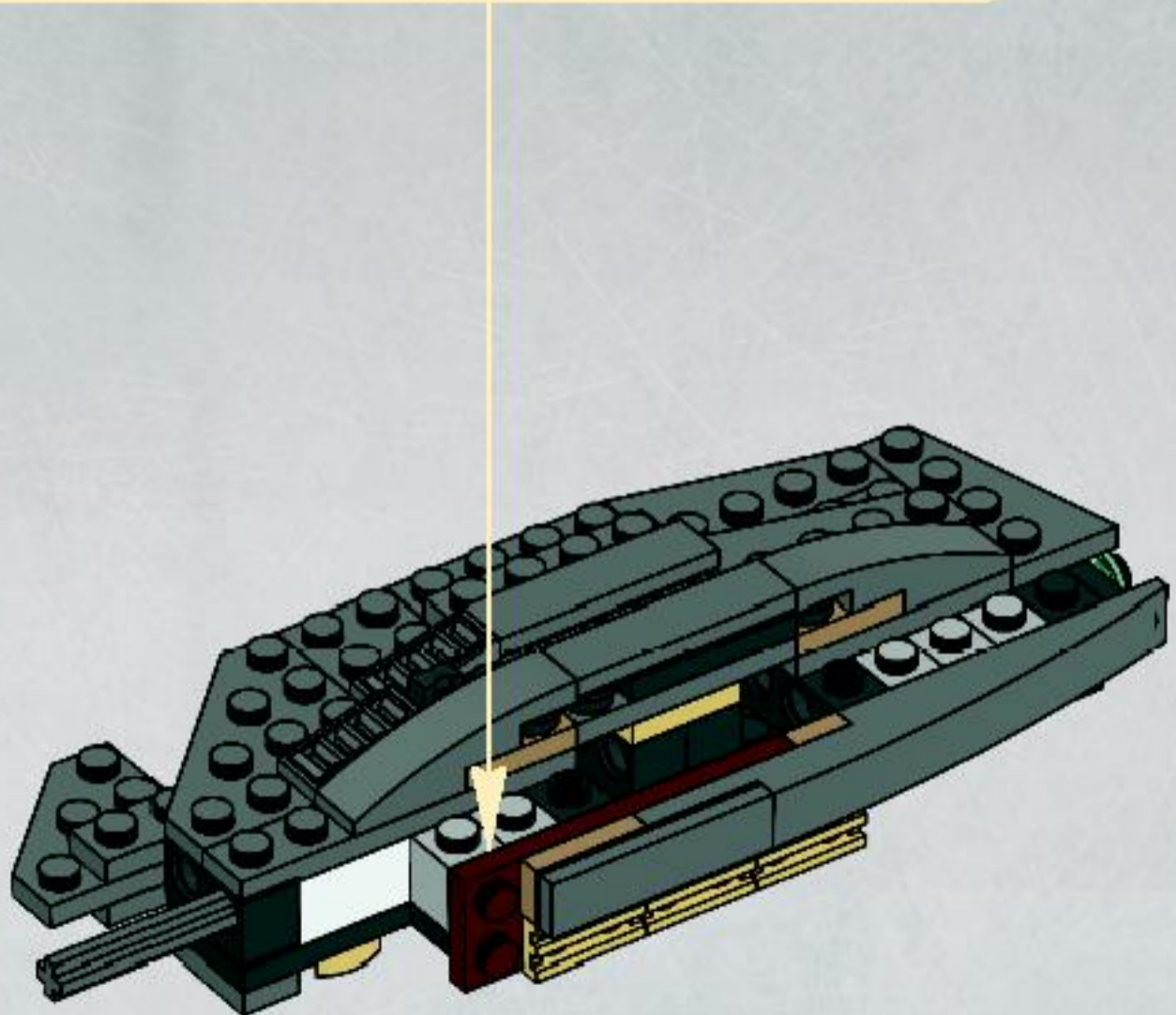
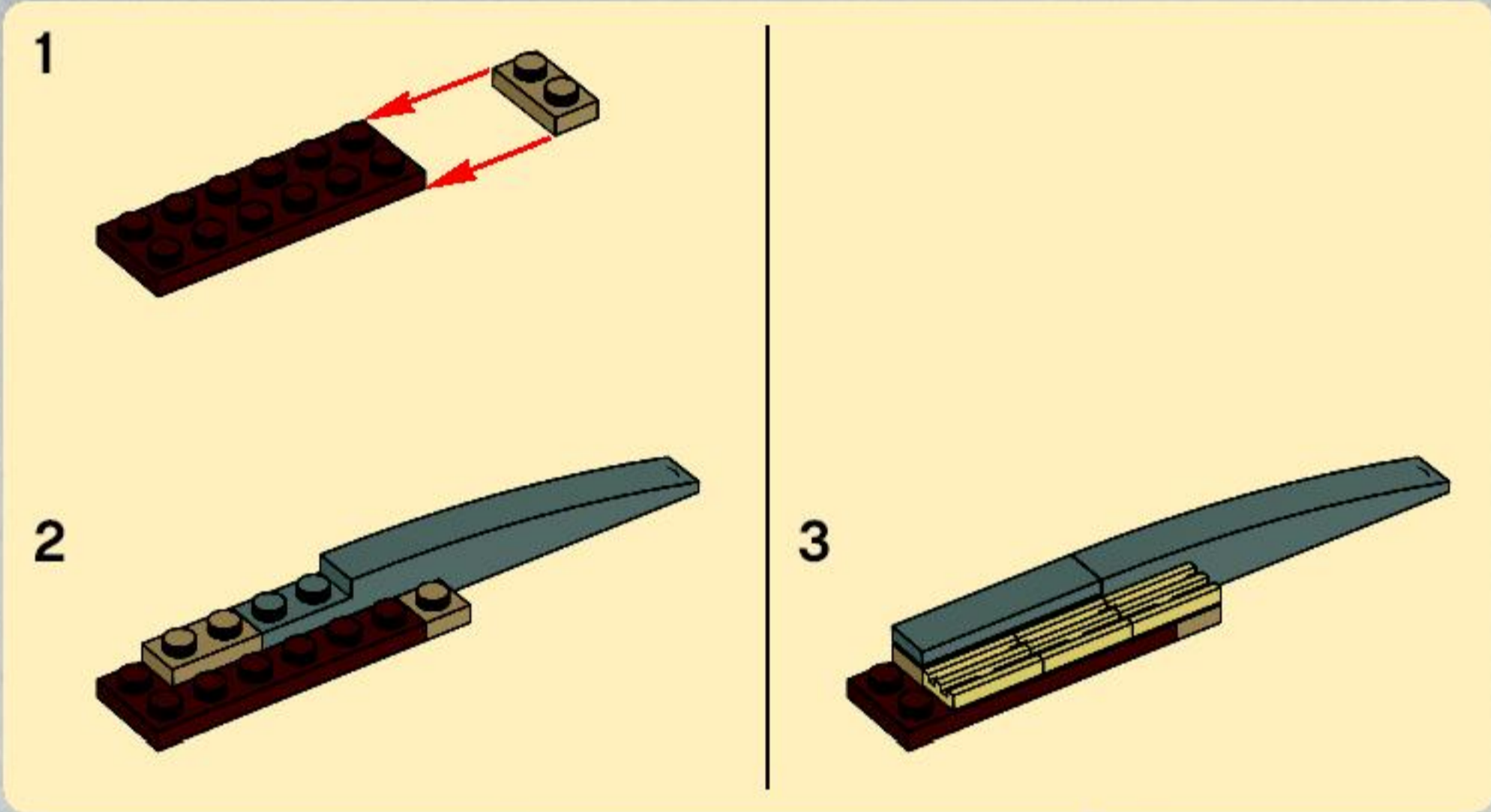



20

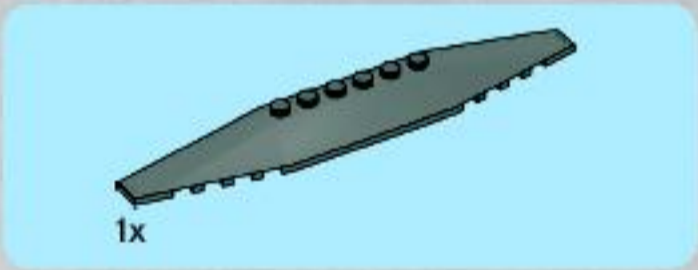
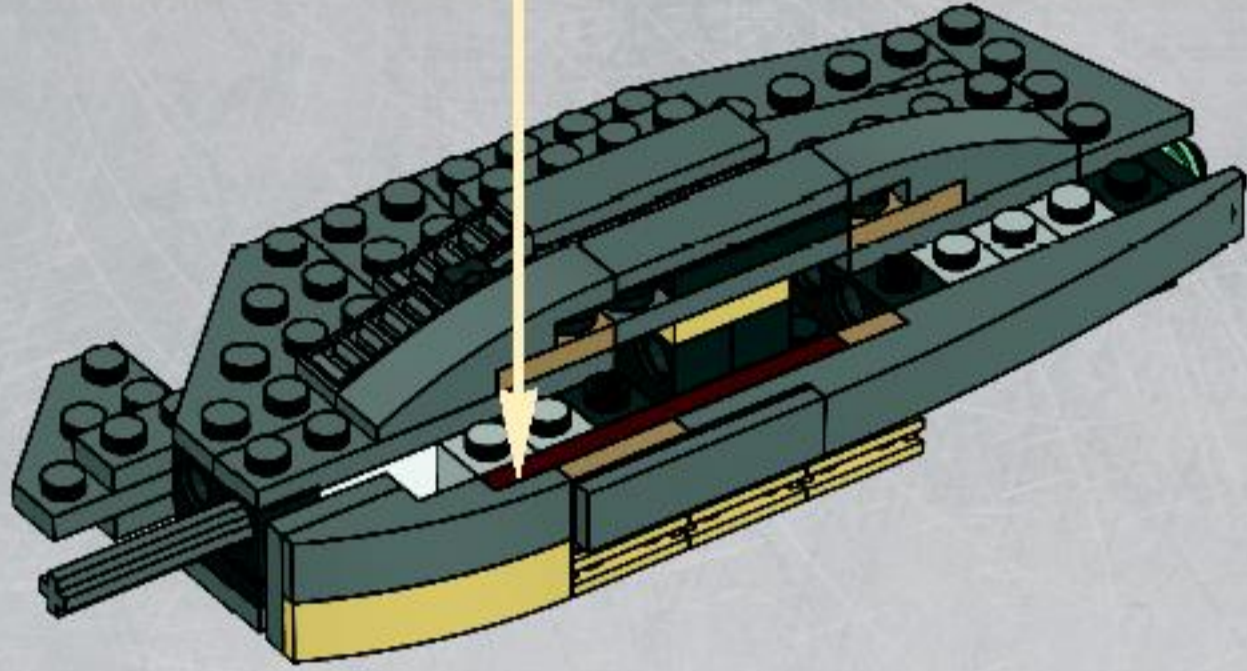
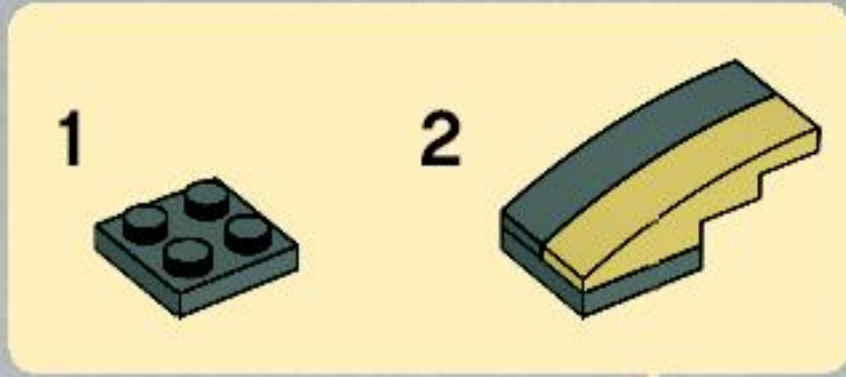

21

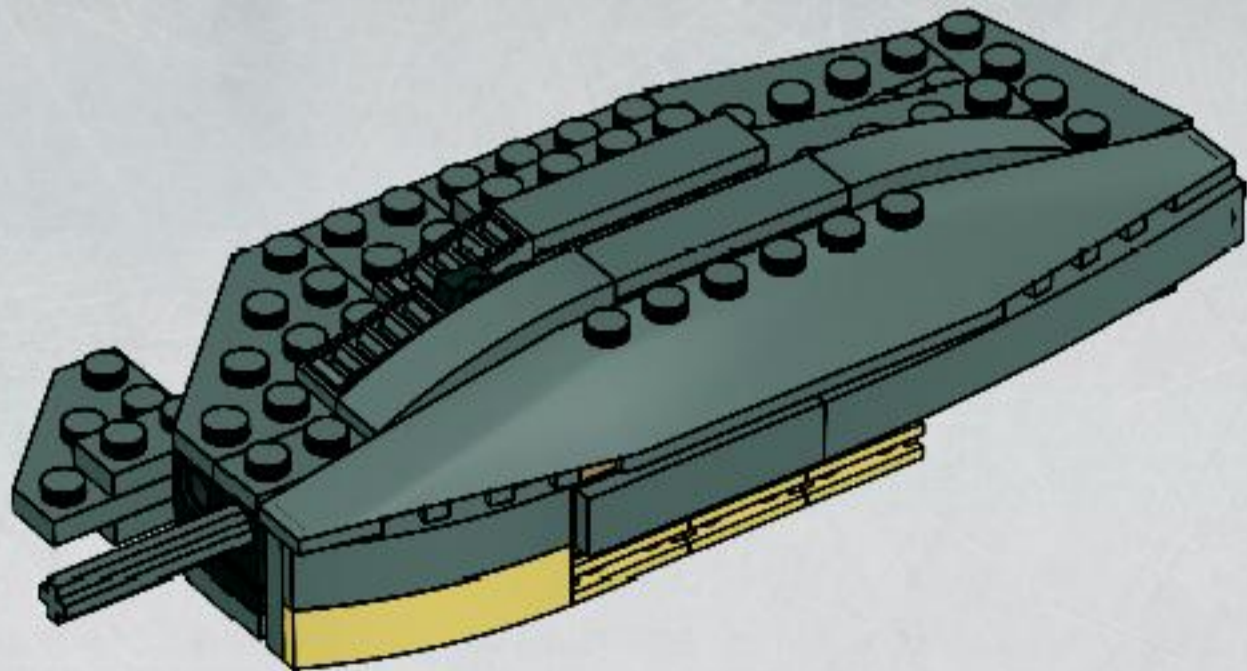



1x

22

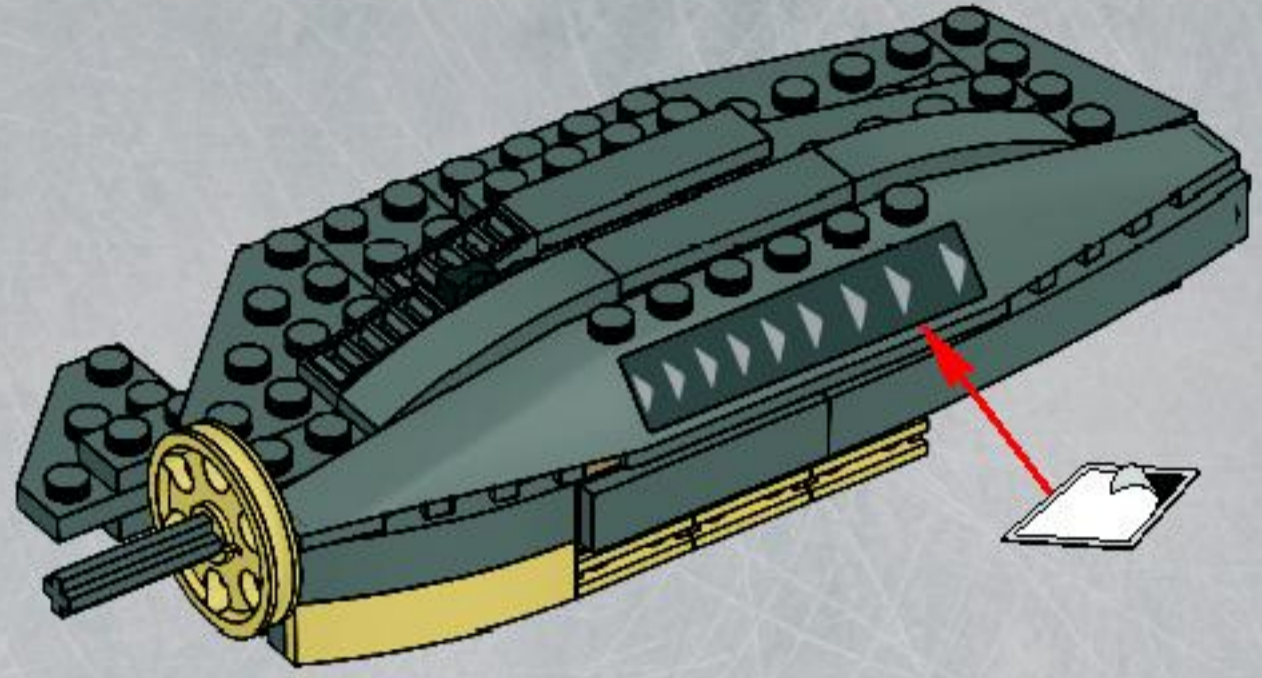

1x



1x

23

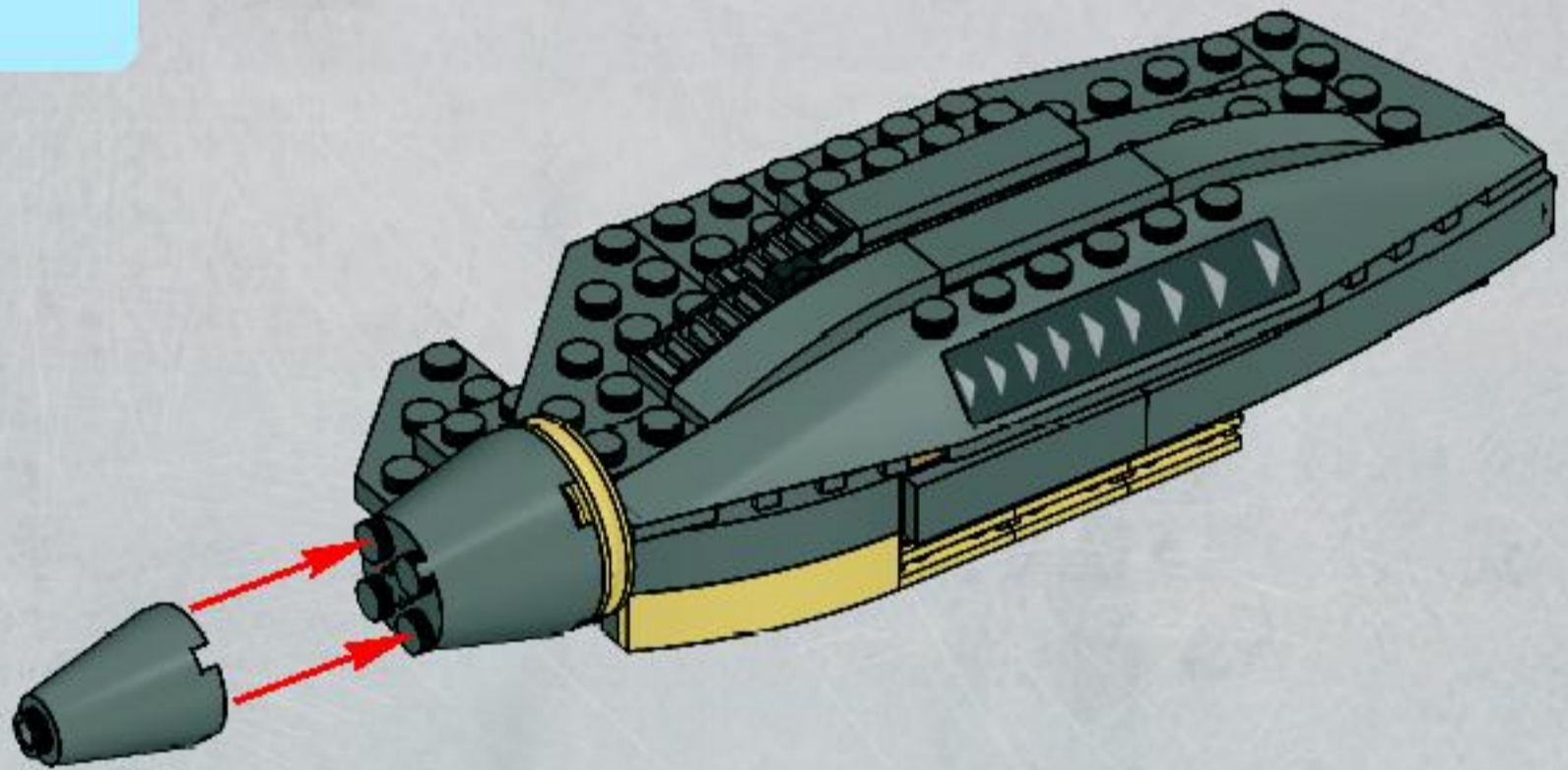

3x

24

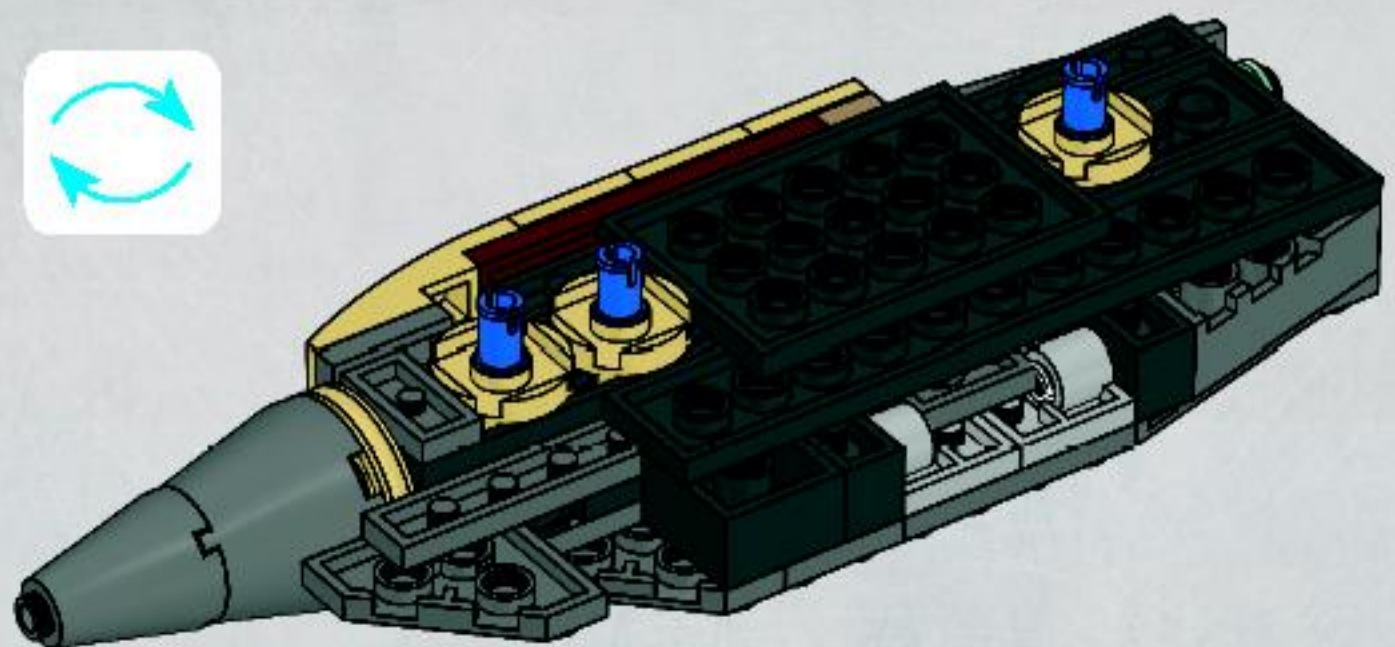



4x



1x



4x

25

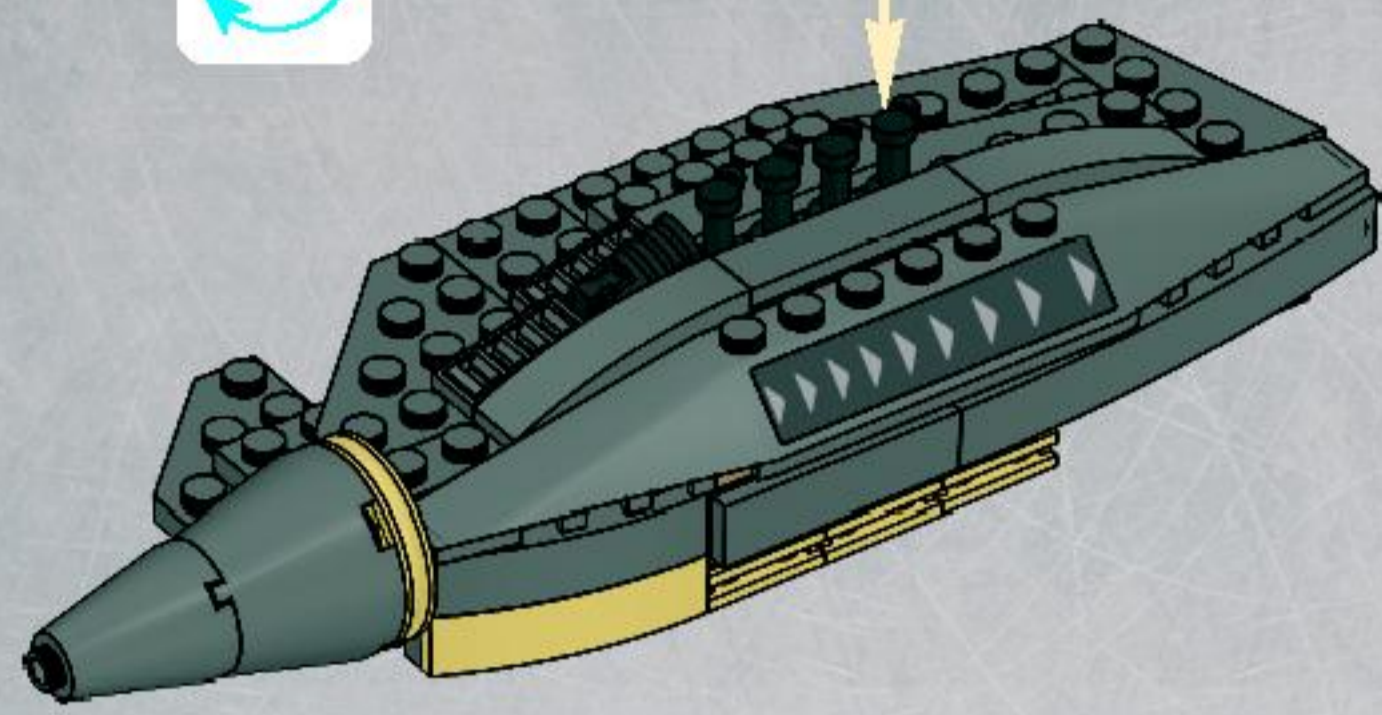

45

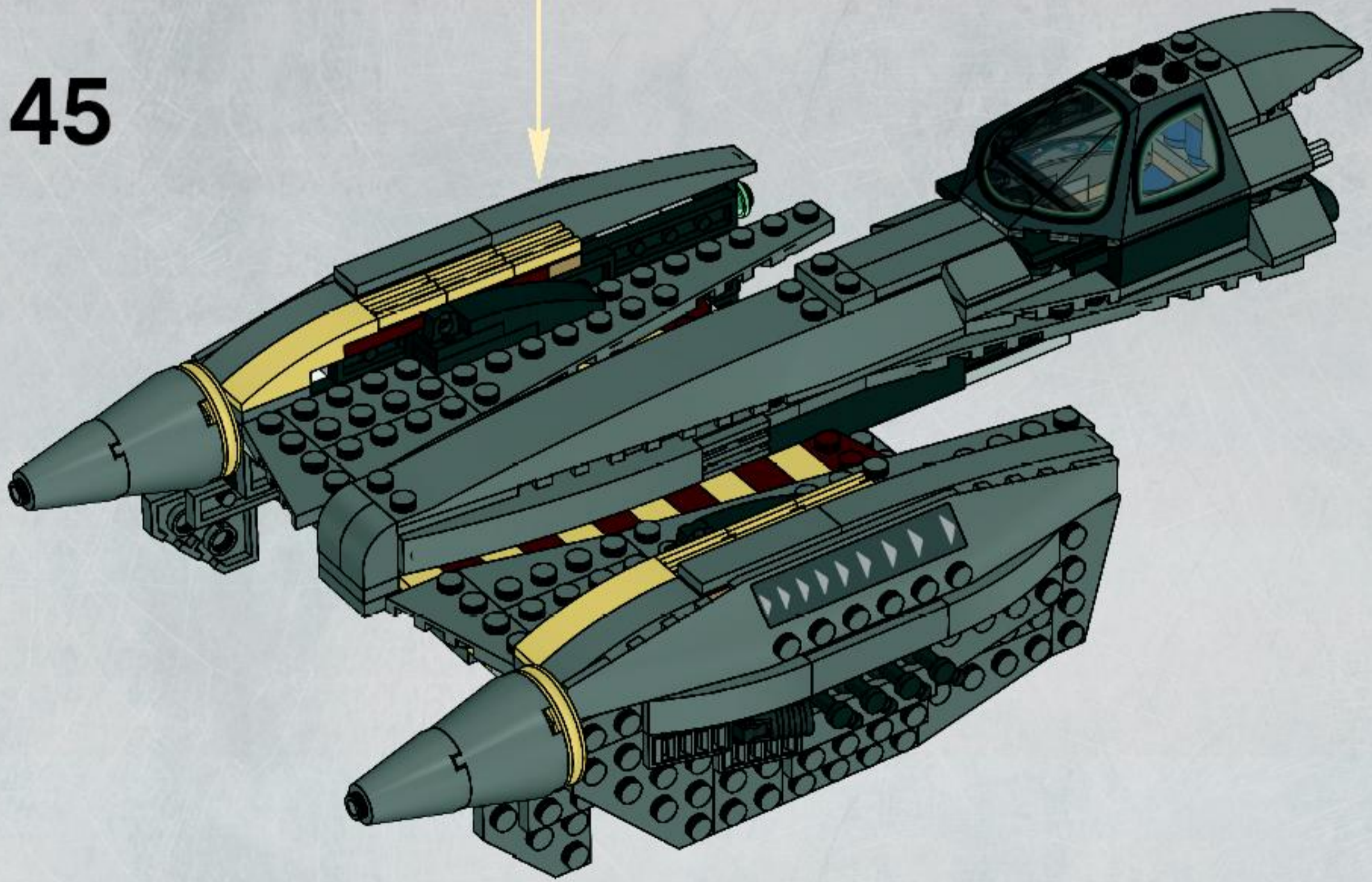

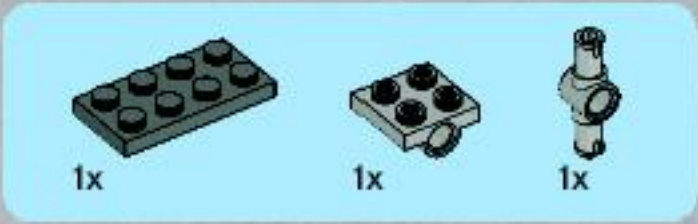

47

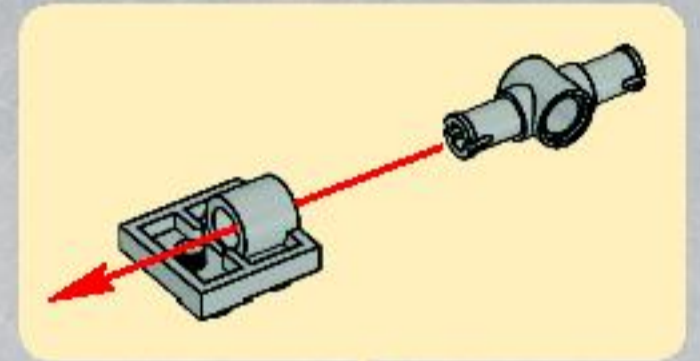
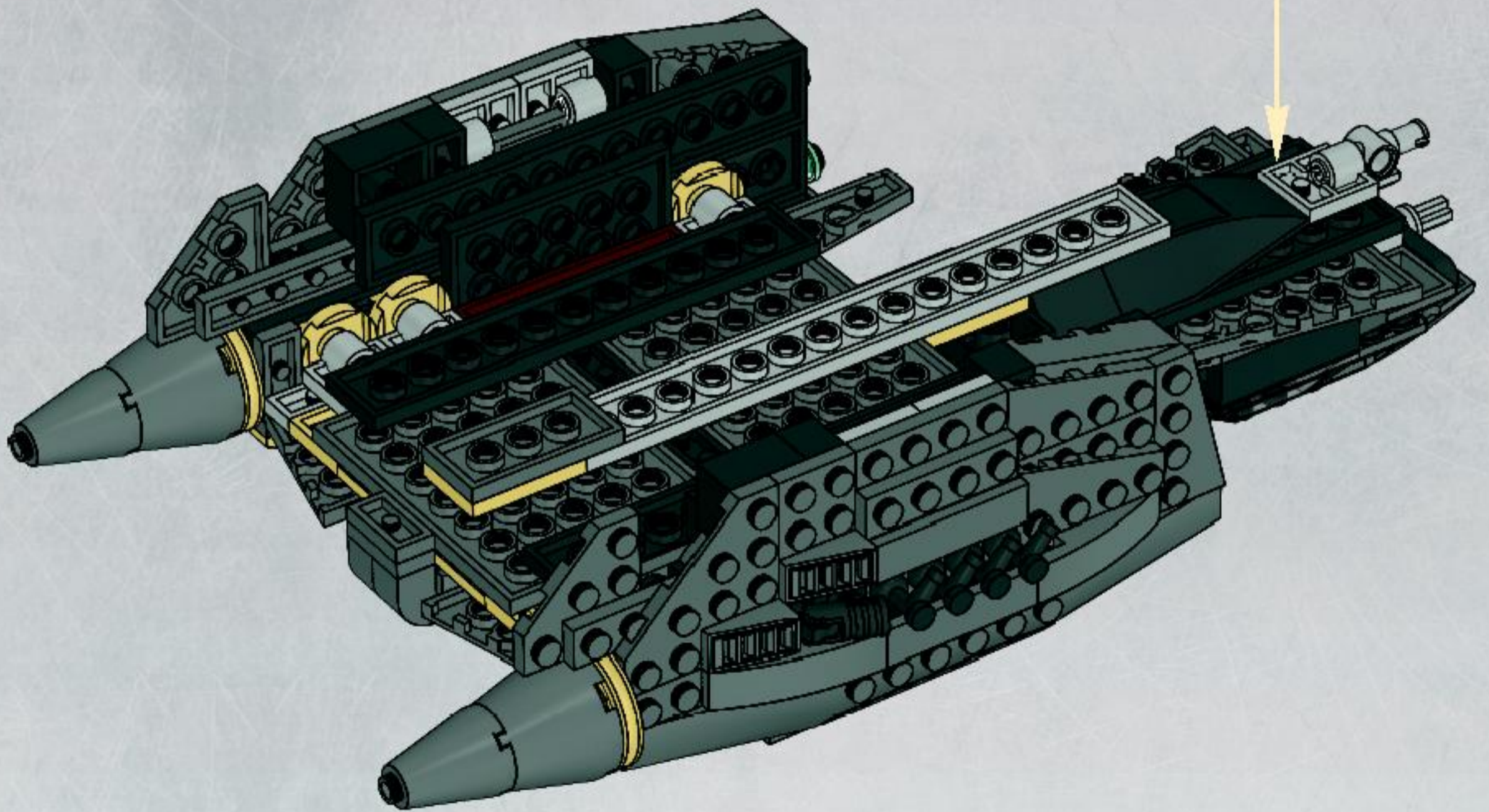

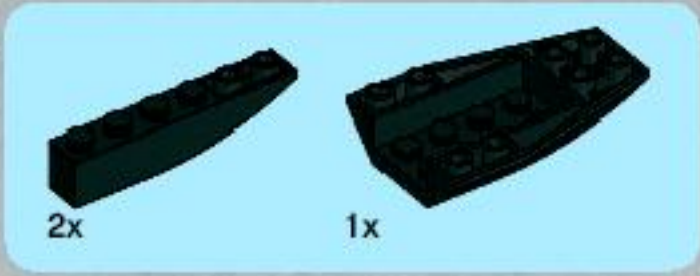

48

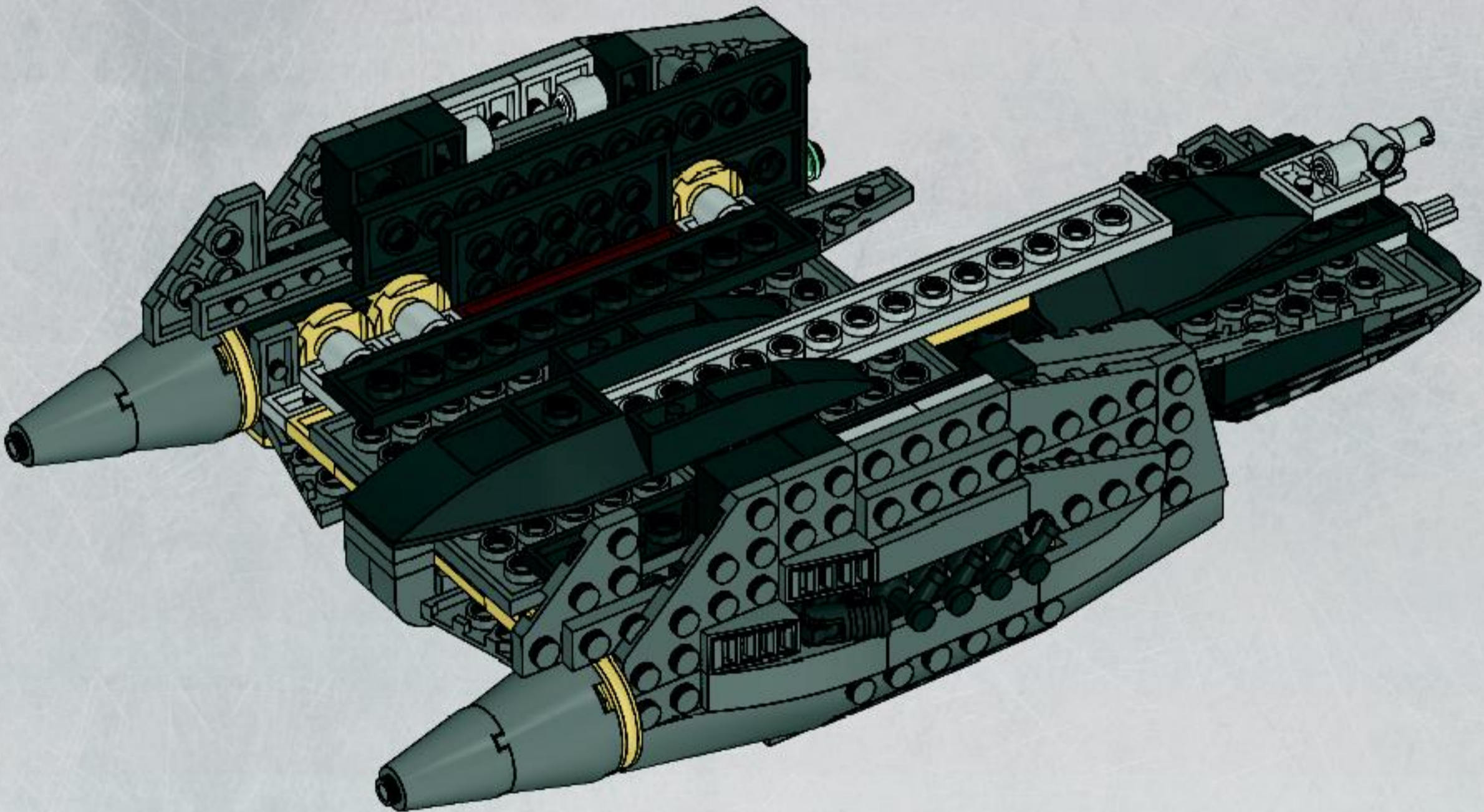

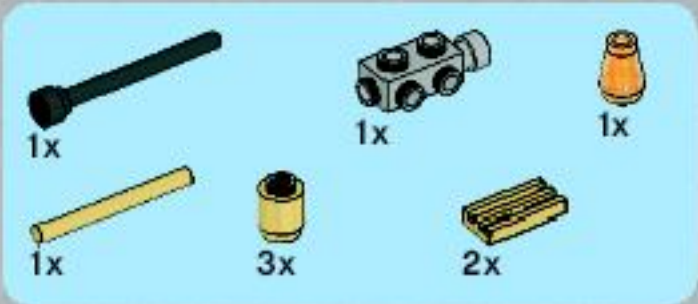

49

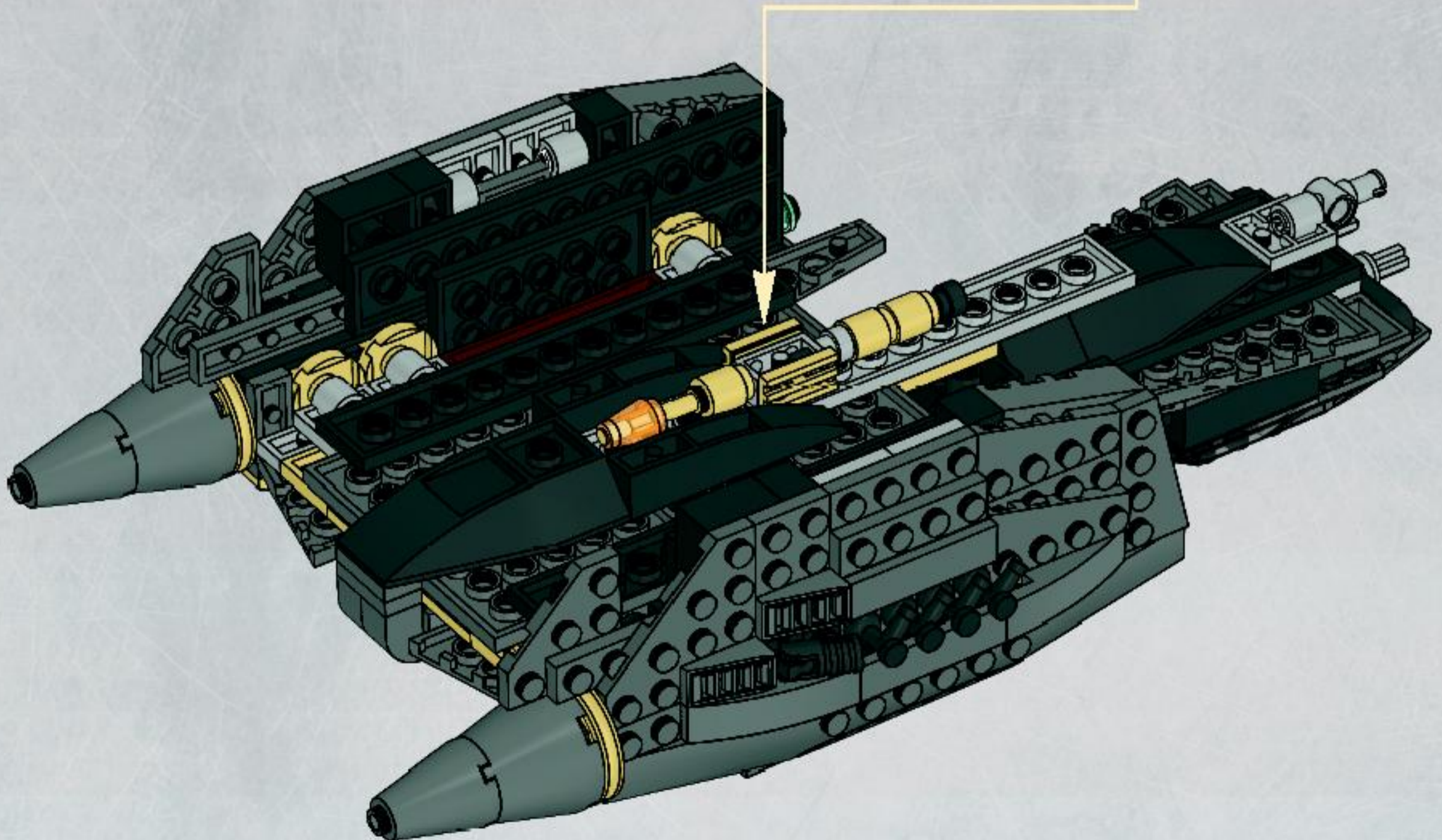
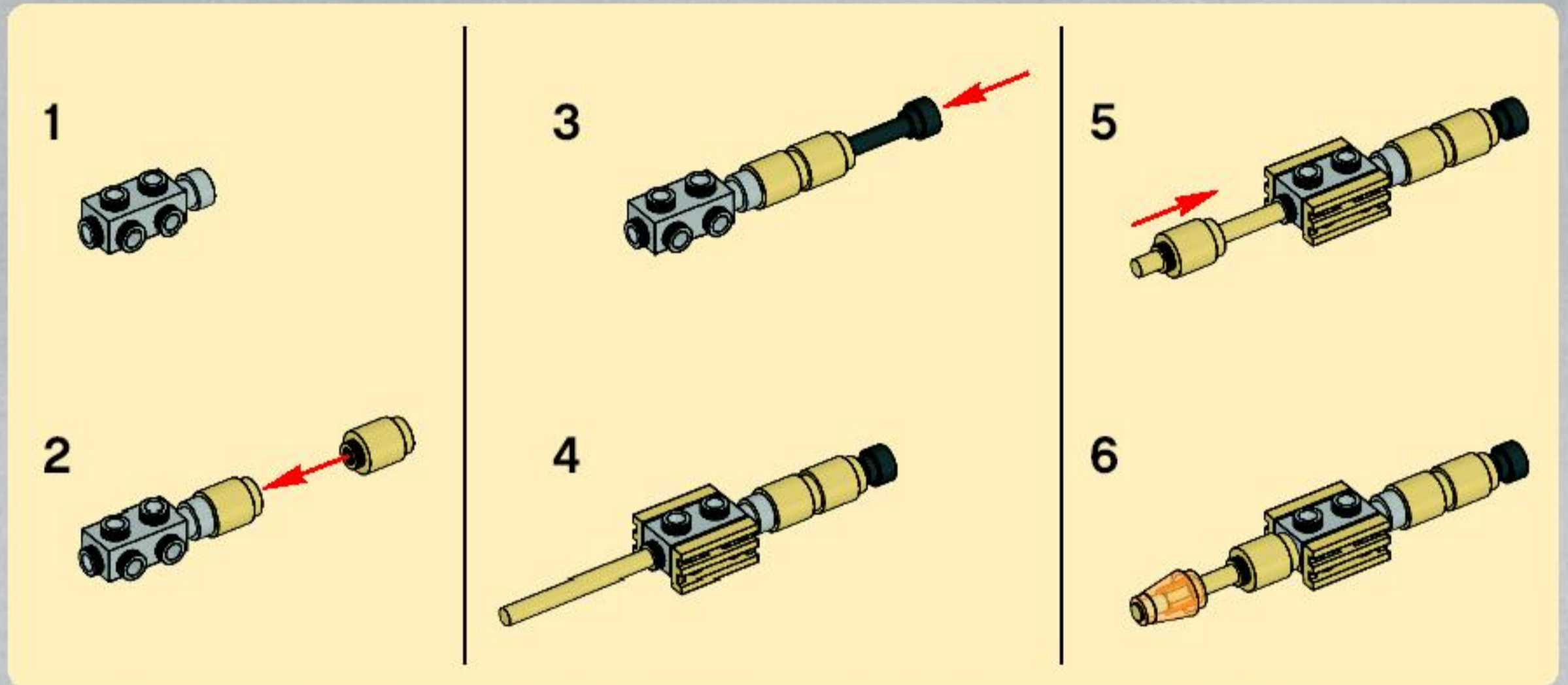



2x

50

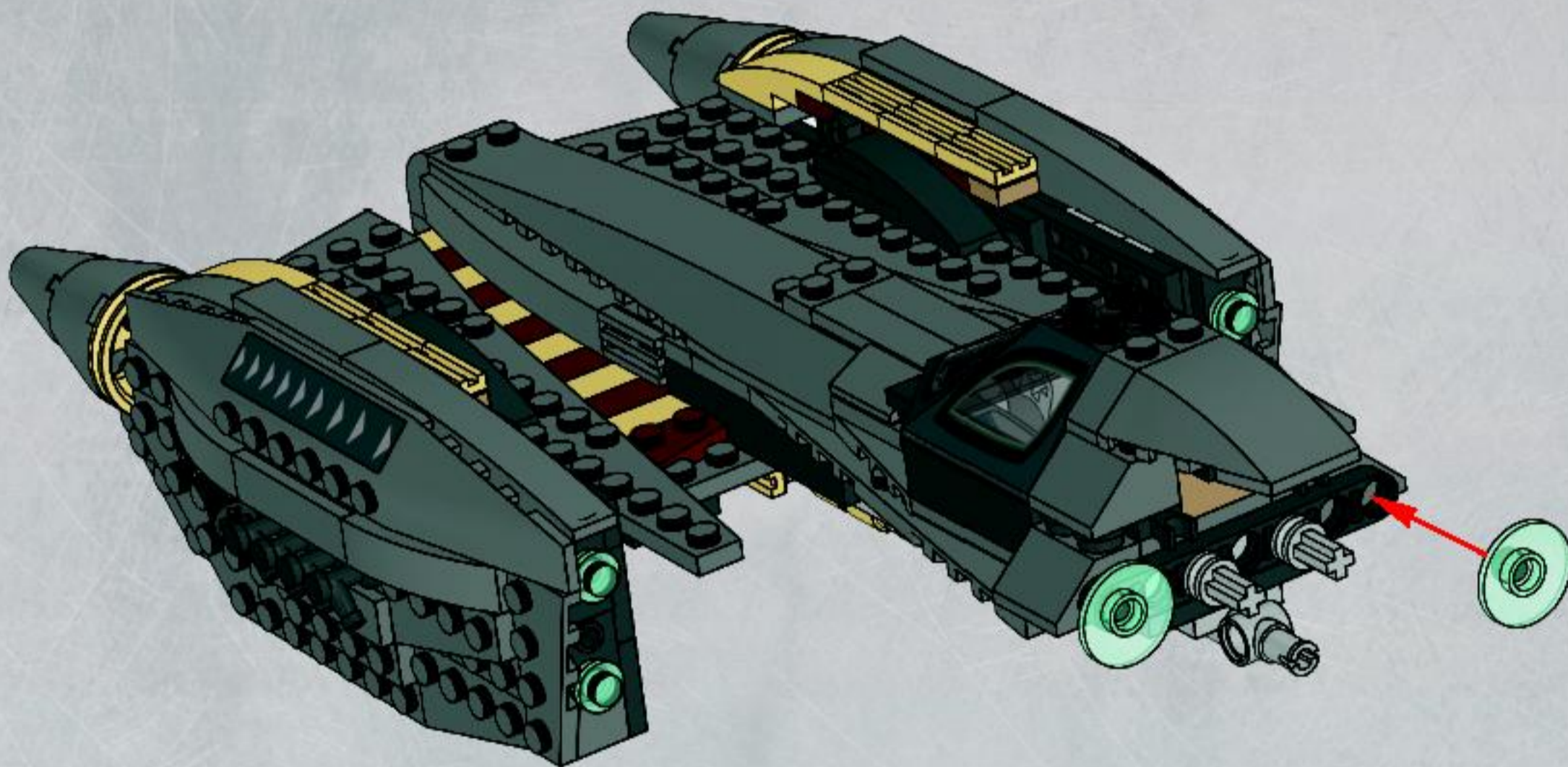

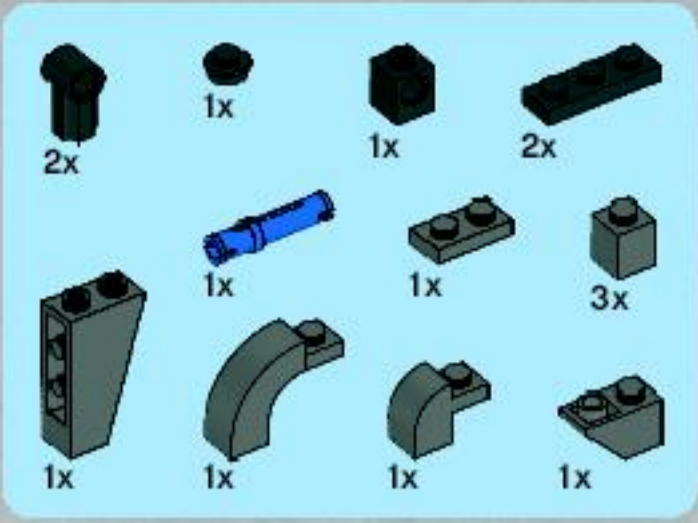

51

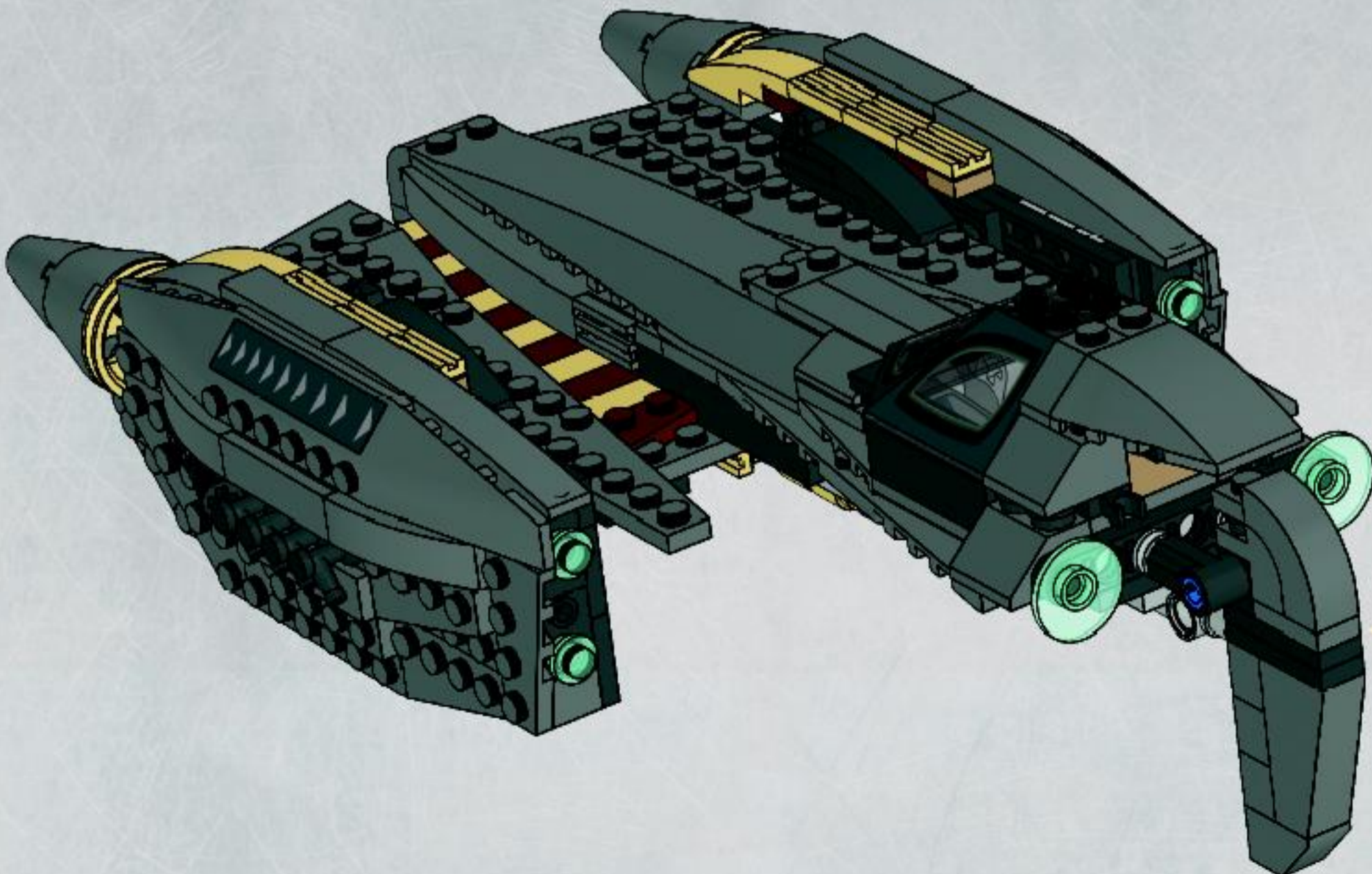
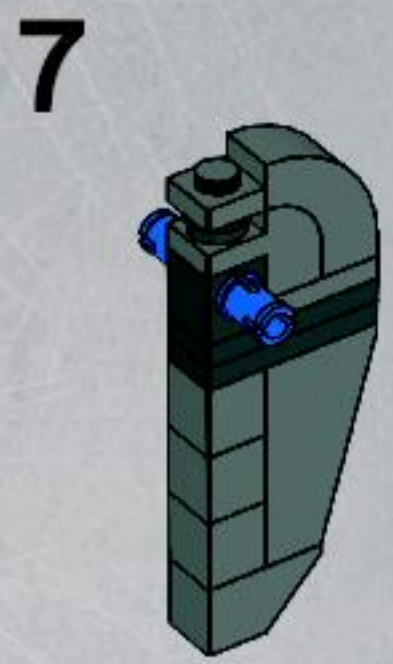
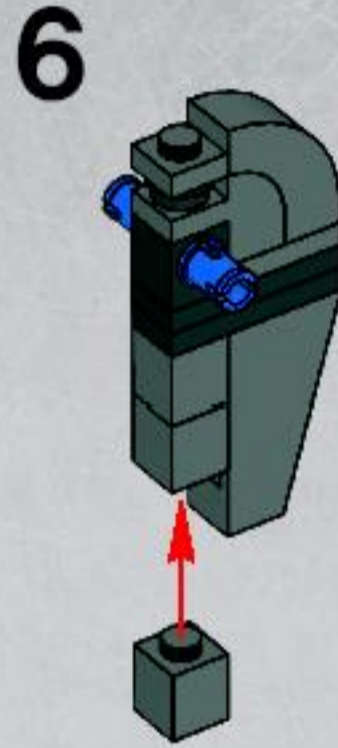
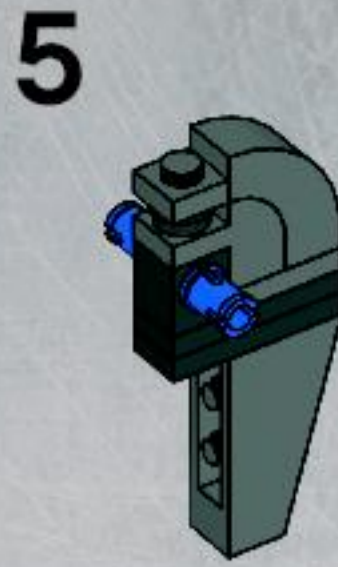
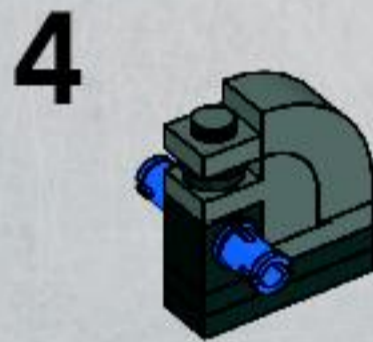
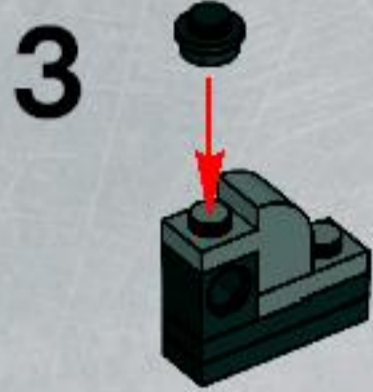
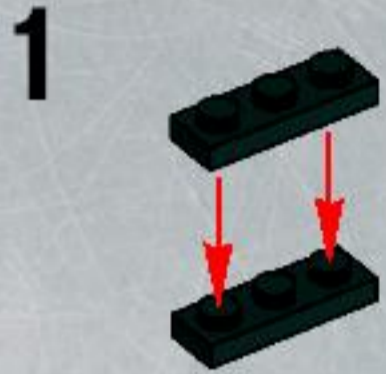



2x



2x

52

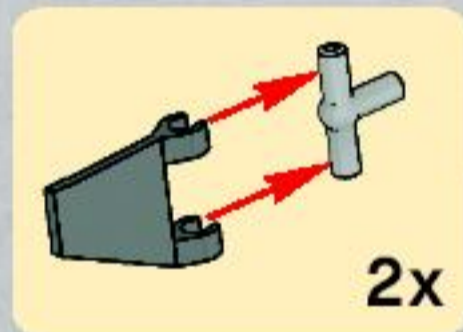
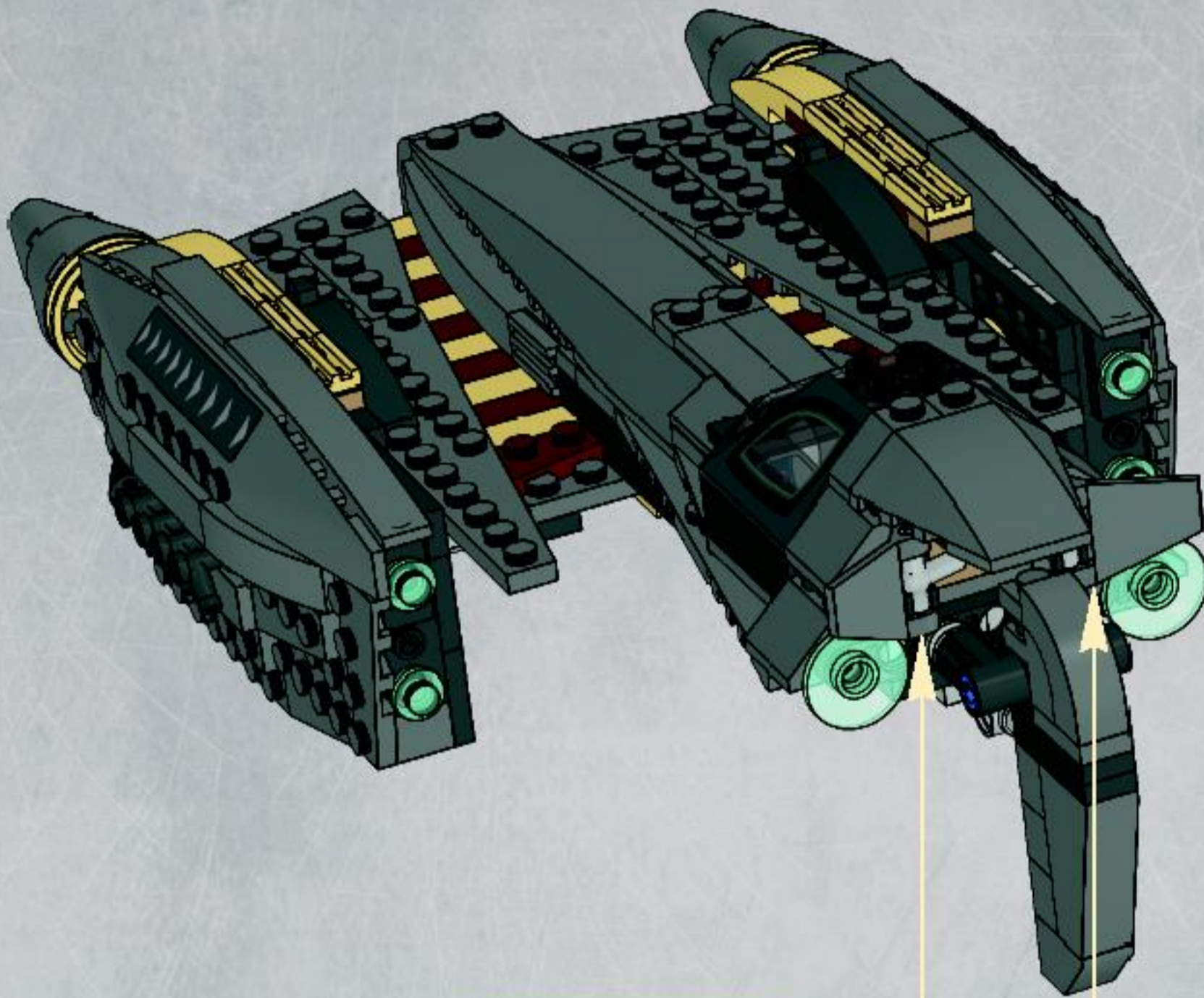

2x

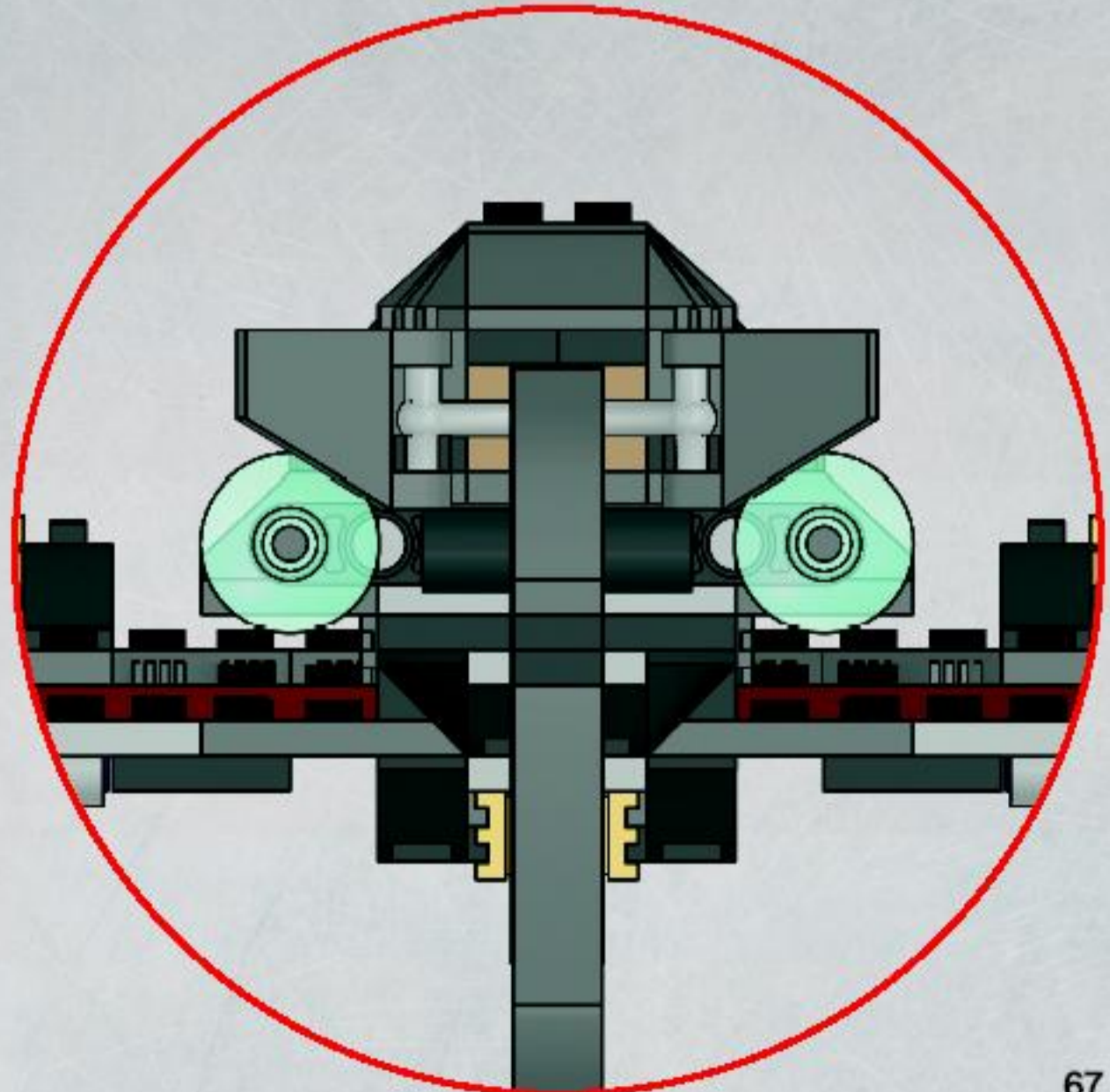



53

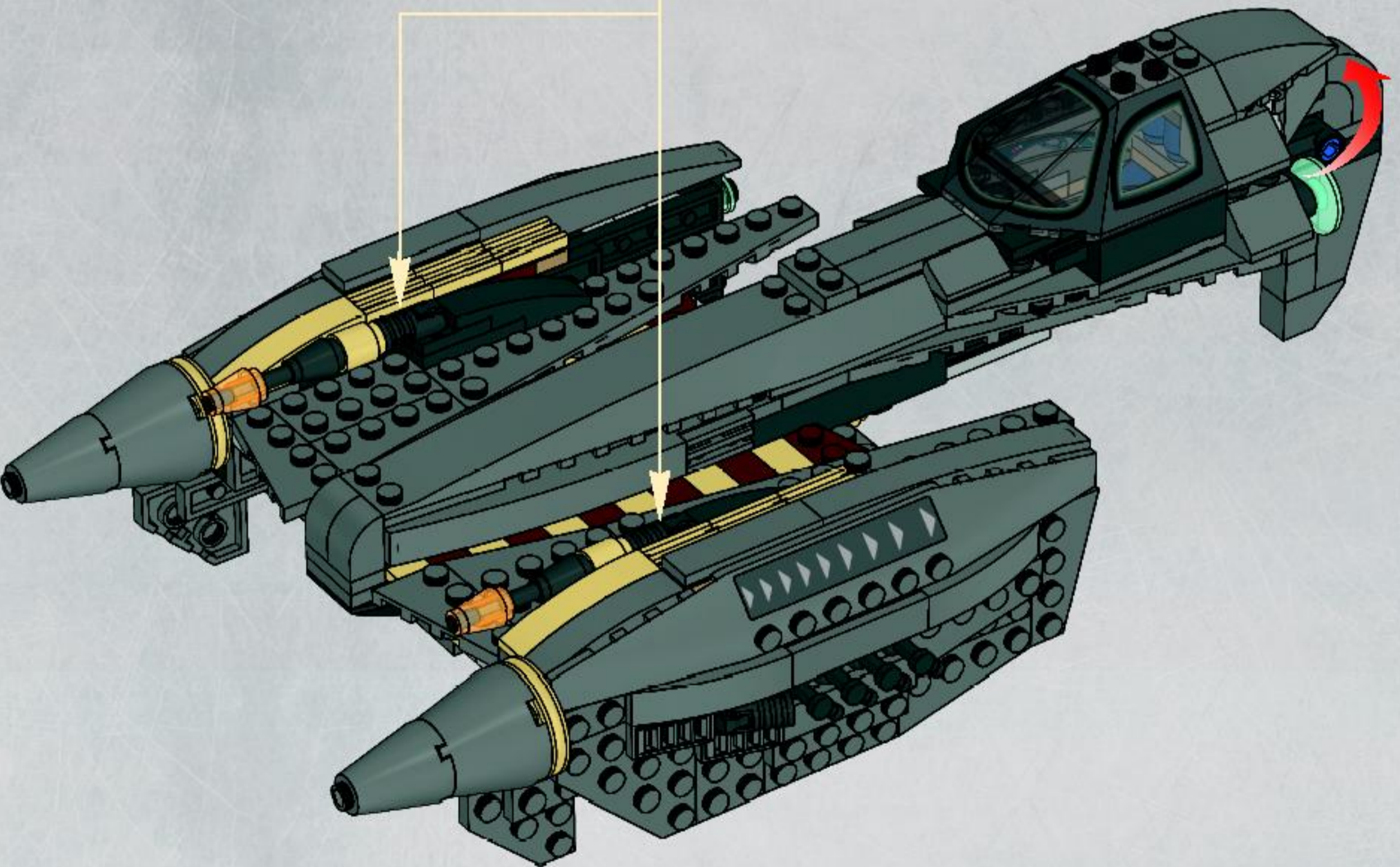
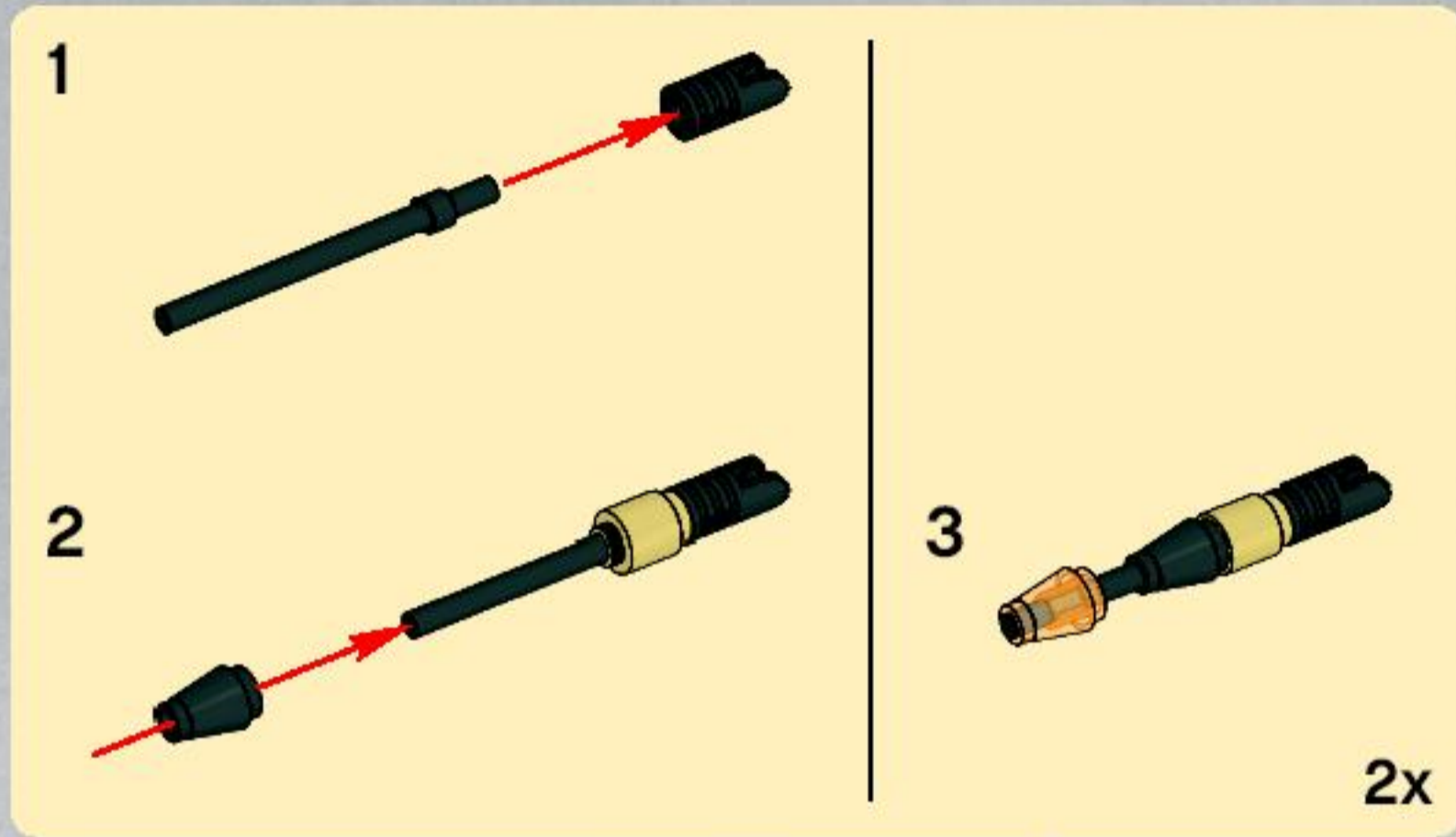



4x



4x



54

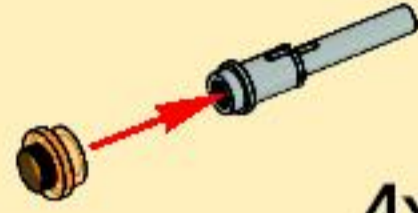

4x

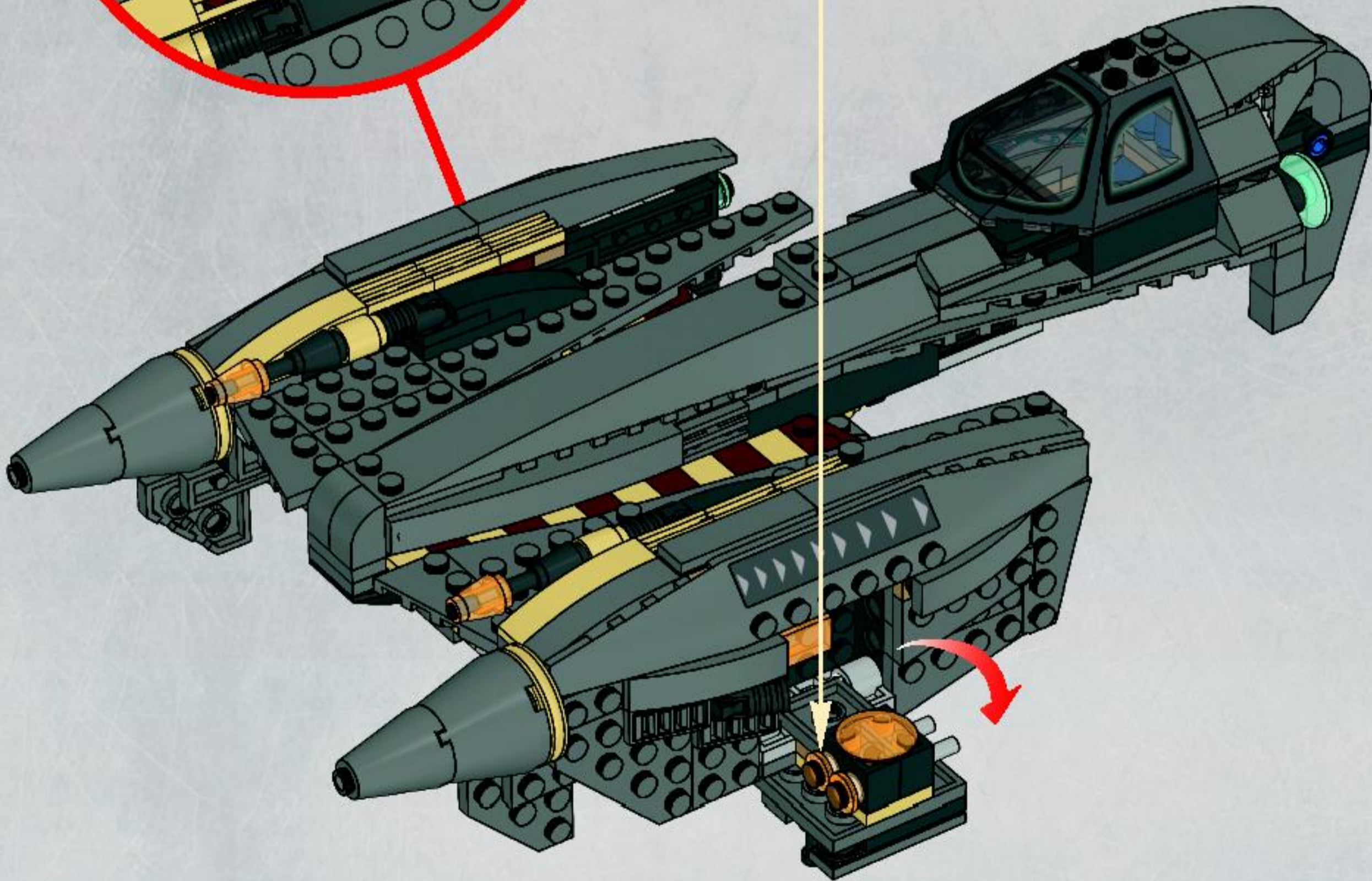
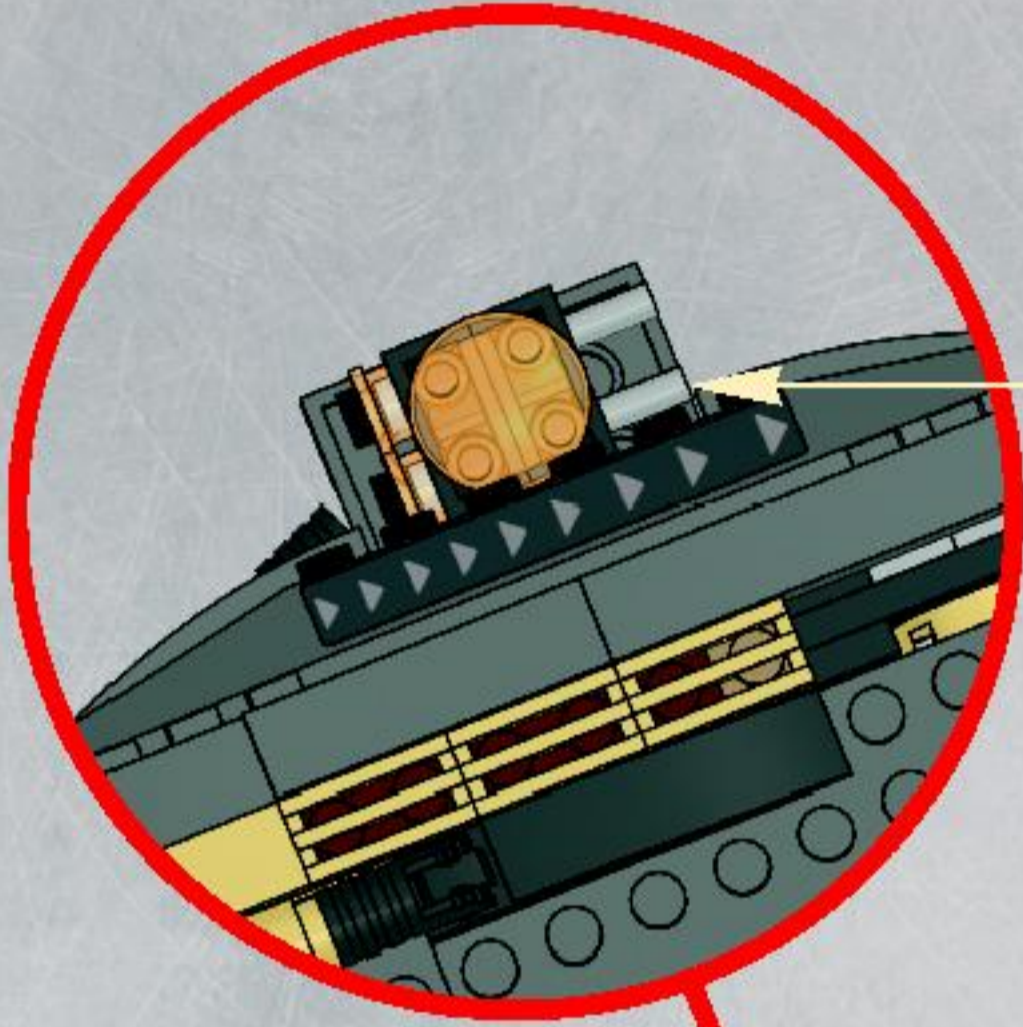

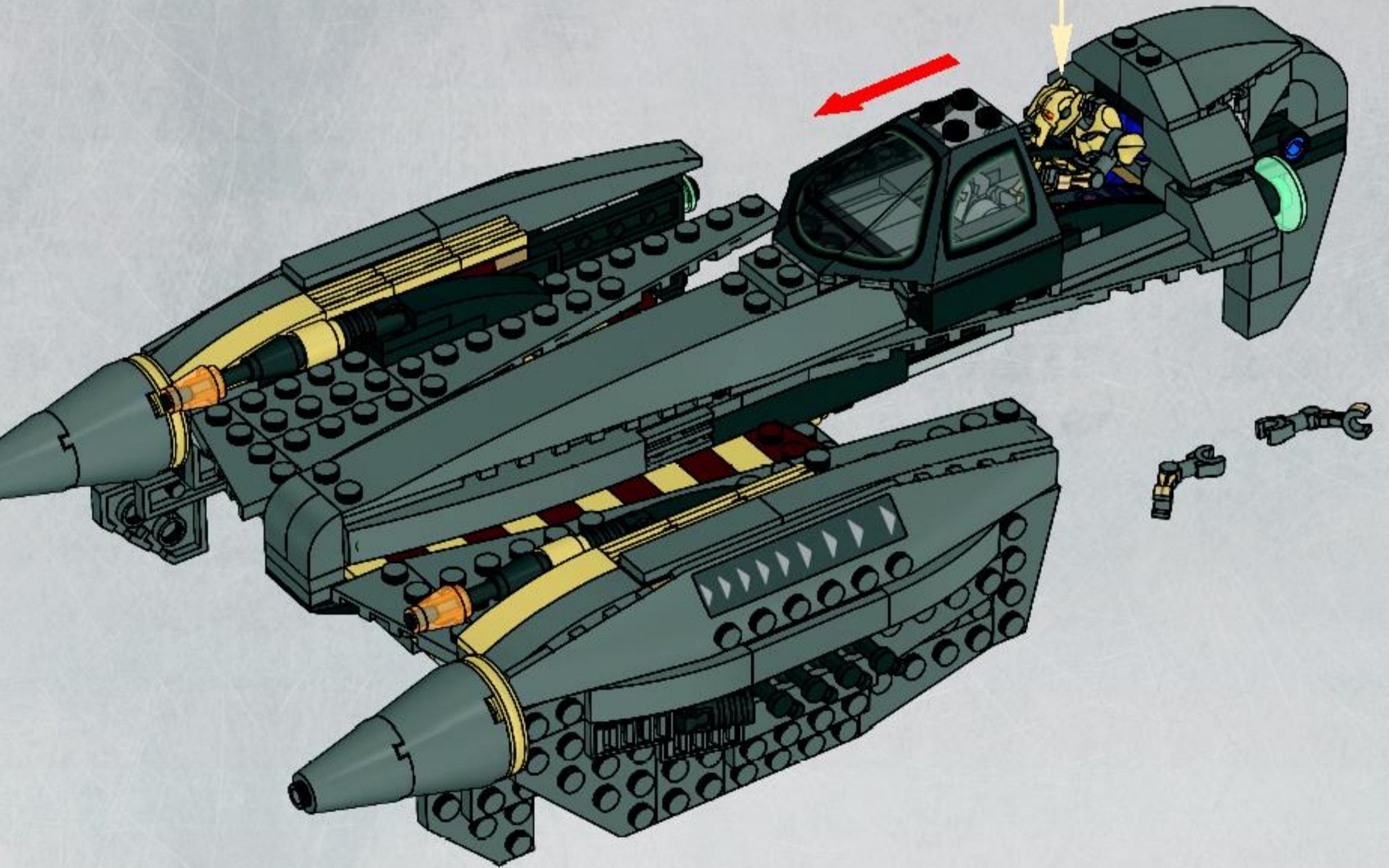
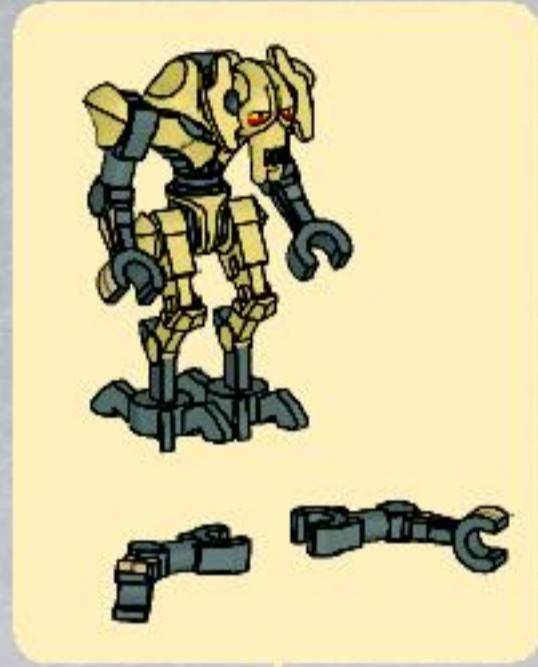

56

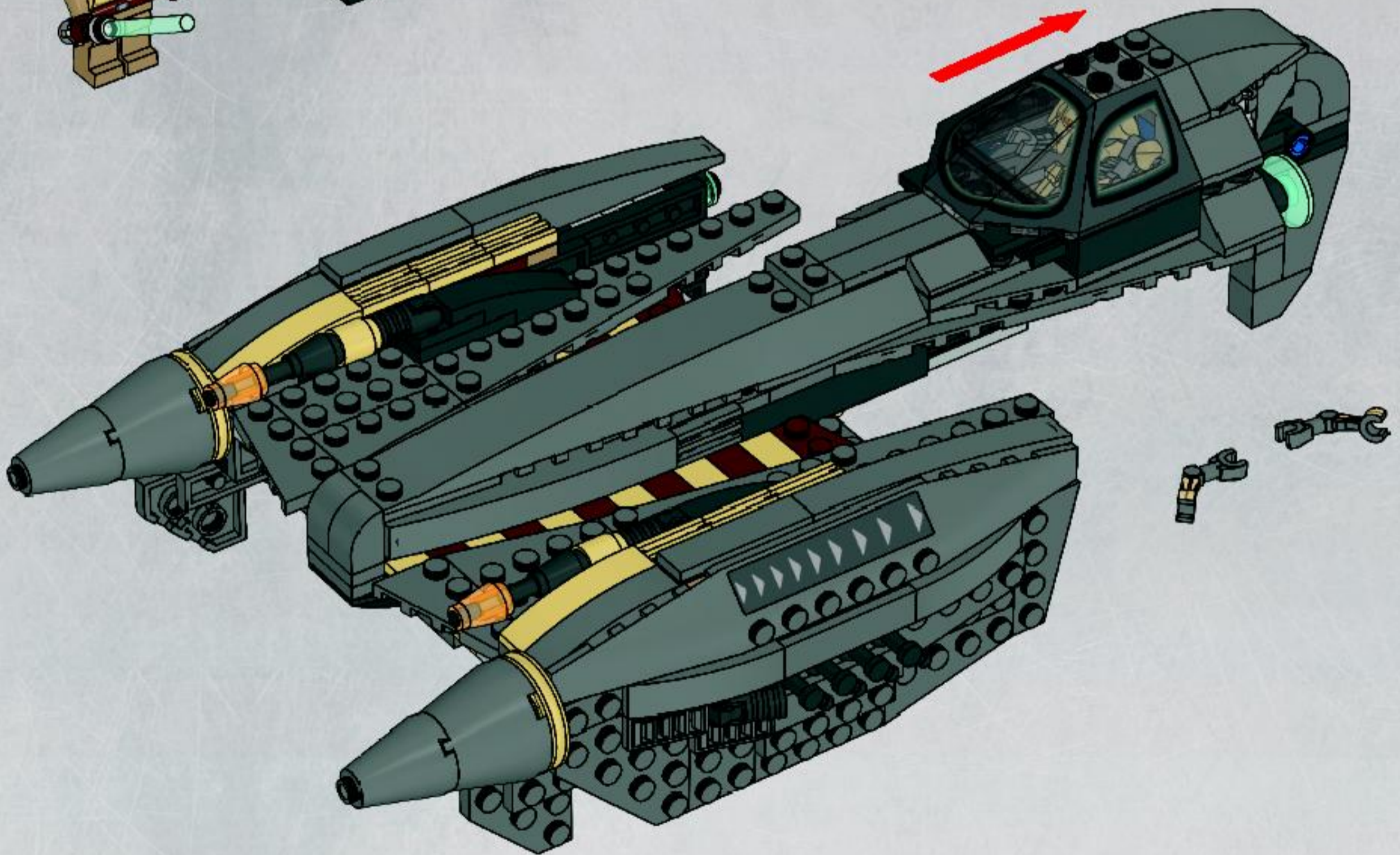
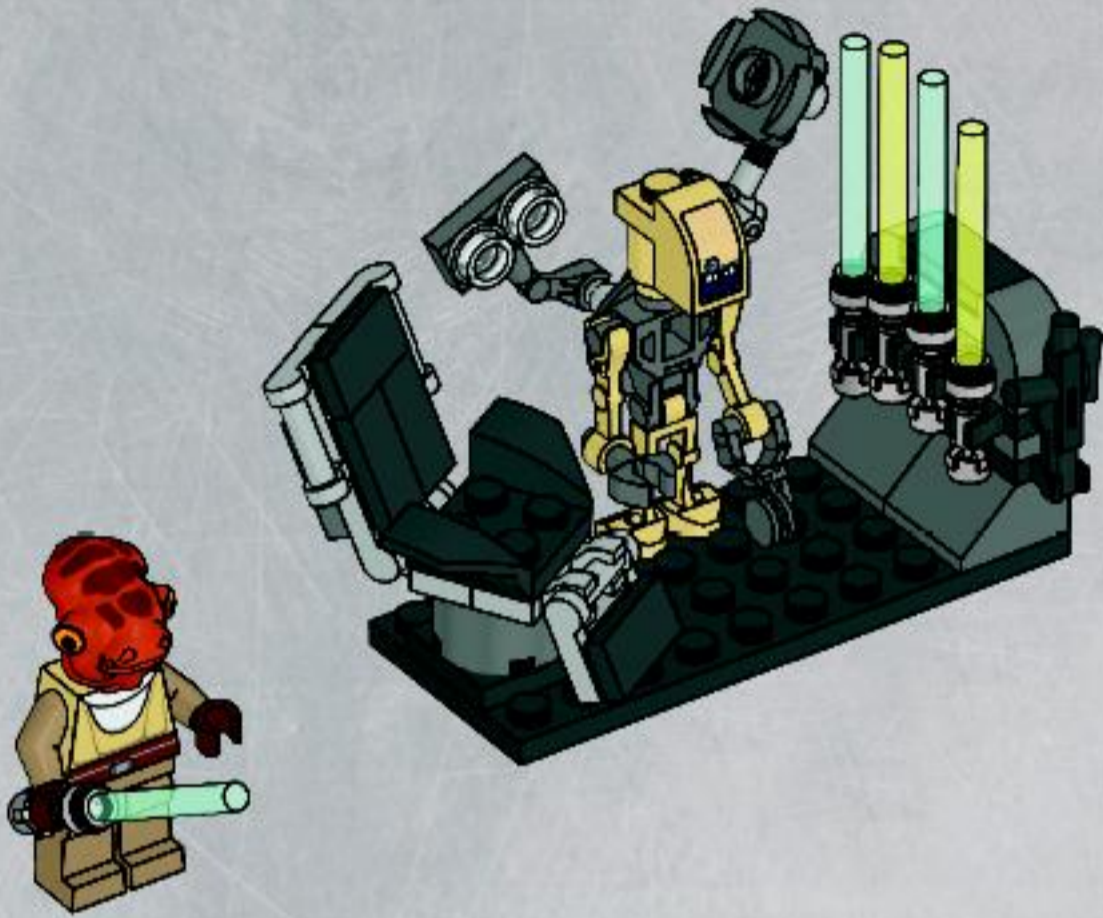





Customer Service
Kundenservice
Service Consommateurs
Servicio Al Consumidor

www.lego.com/service or dial

00800 5346 5555 : 

1-800-422-5346 : 

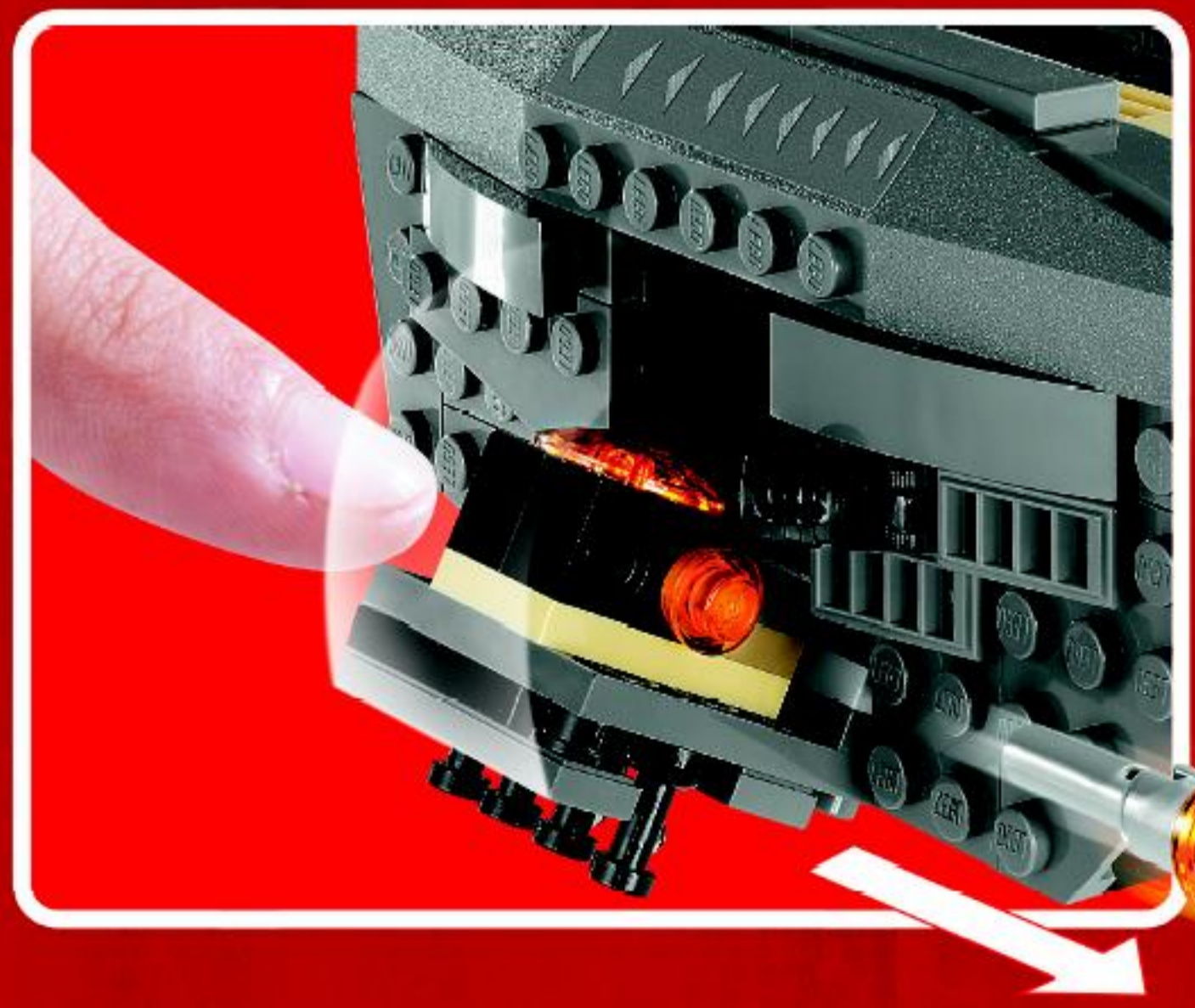
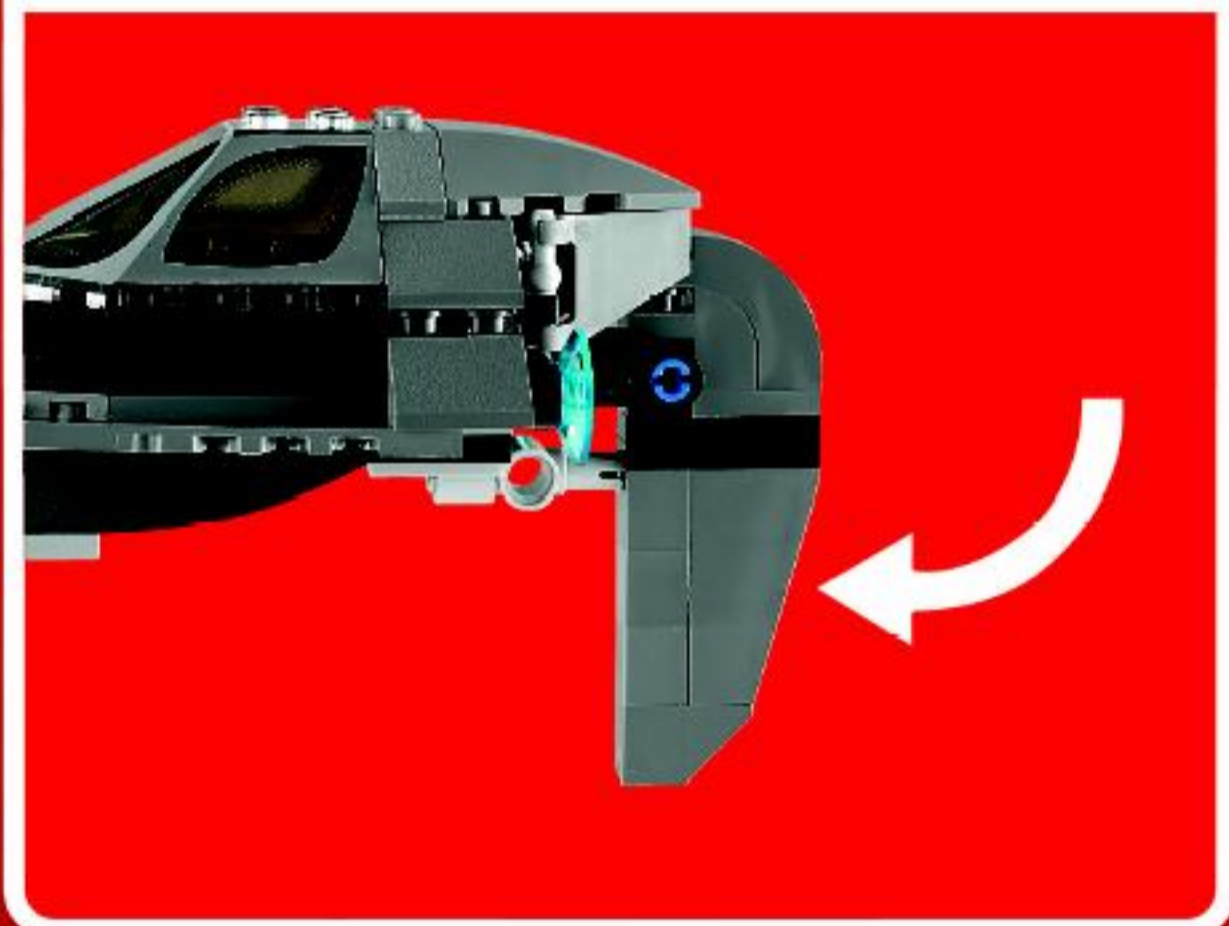
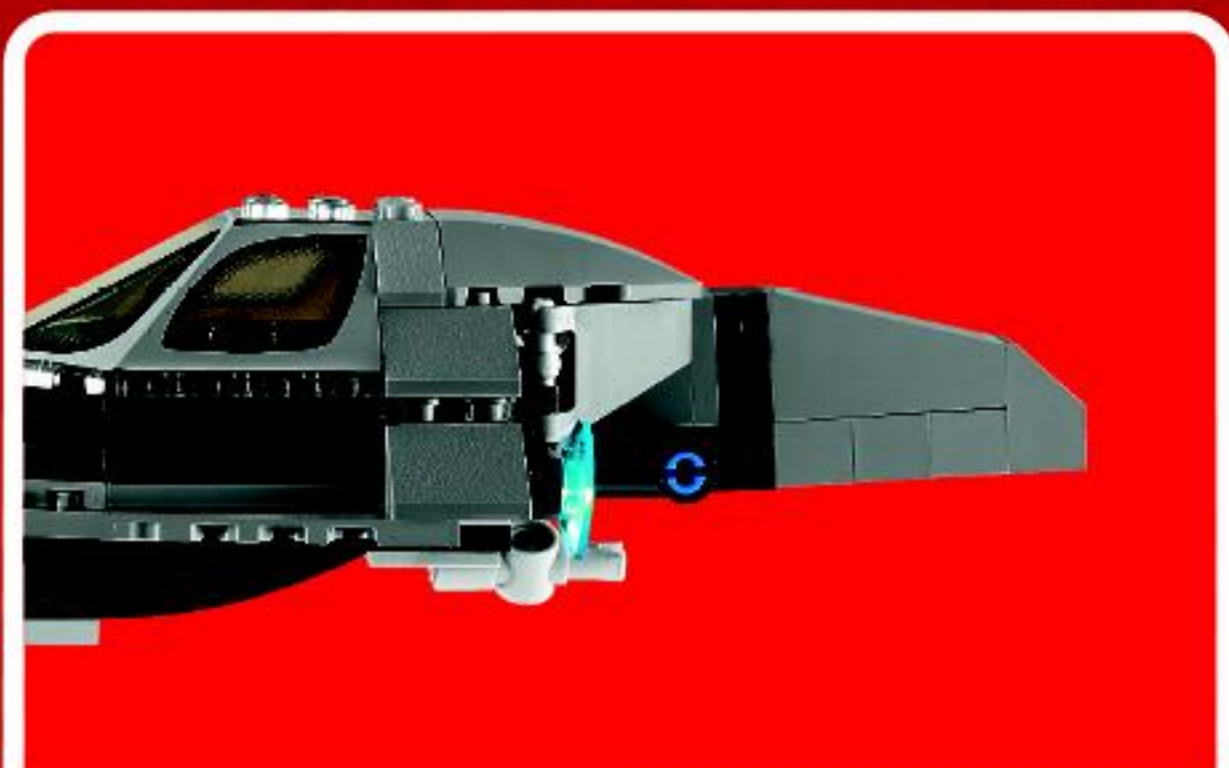



STAR WARS III

THE CLONE WARS™

Videogame coming fall 2010

www.videogames.LEGO.com



STAR WARS





WIN!



Go to www.nielsen.com/LEGO to fill out a survey for a chance to win a cool LEGO® Product. No purchase necessary. Open to all residents where not prohibited.

 www.LEGO.com

www.nielsen.com/LEGO

GEWINNE!

Nimm an der Umfrage auf www.nielsen.com/LEGO teil und hab die Chance ein cooles LEGO® Produkt zu gewinnen!
Die Teilnahme am Gewinnspiel führt zu keinerlei Kaufverpflichtungen. Teilnahme in allen nicht ausgeschlossenen Ländern möglich.

WIN!

Ga naar www.nielsen.com/LEGO, vul een enquêteformulier in en maak kans op een cool LEGO® product.
Geen aankoopverplichting. Iedereen mag deelnemen, uitgezonderd ingezetenden van landen waar een enquêteverbod geldt.

GAGNE!

Visite www.nielsen.com/LEGO pour répondre à un questionnaire et avoir une chance de gagner un produit LEGO® très cool!
Aucune obligation d'achat. Ouvert à tous les résidents des pays autorisés.

当てよう!

www.nielsen.com/LEGOにアクセスして、アンケートにご記入ください。当選者にはレゴ製品を差し上げます。
お買い上げの必要はありません。禁止されていない限り、すべての年齢にご利用いただけます。