

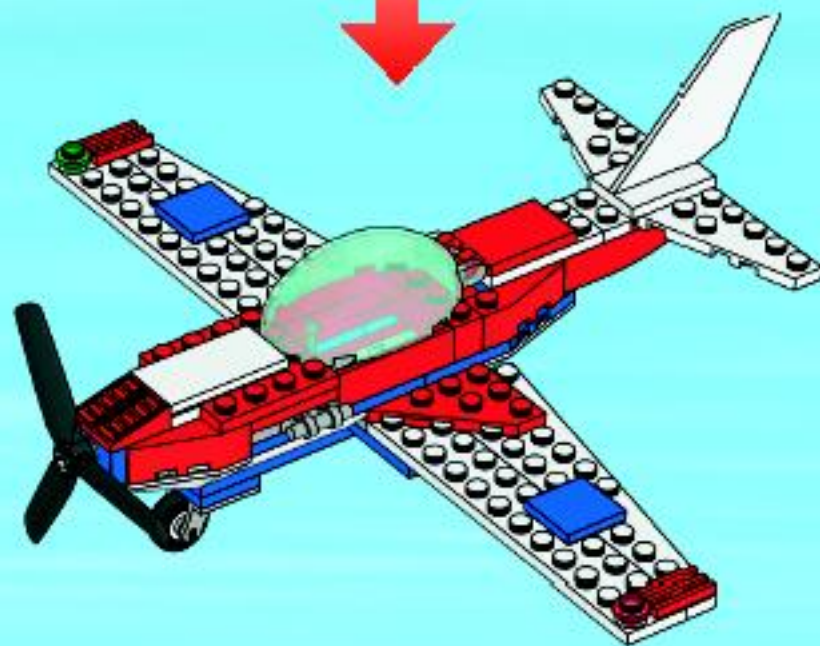

7688

# CITY







1

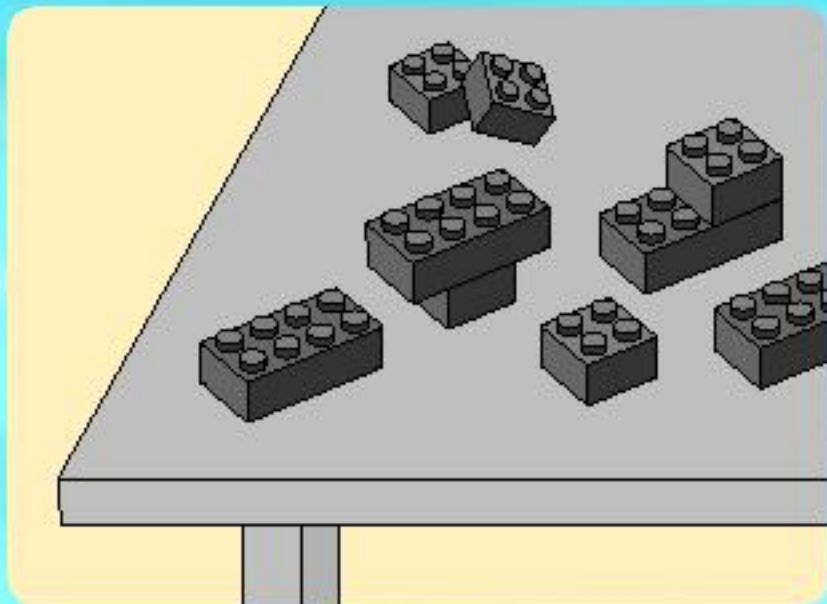

2

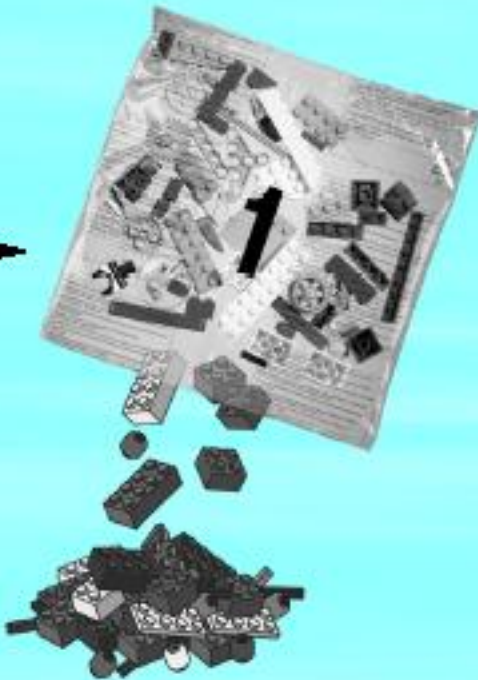

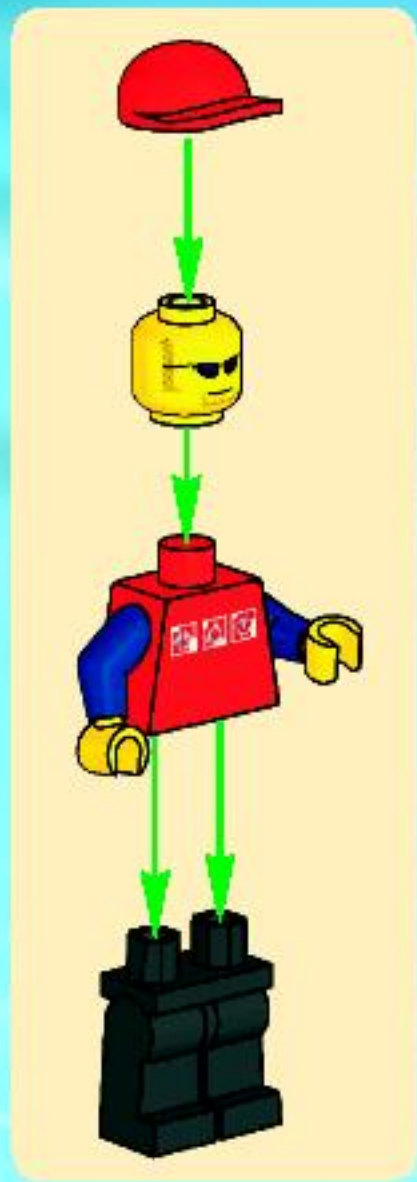

1



2

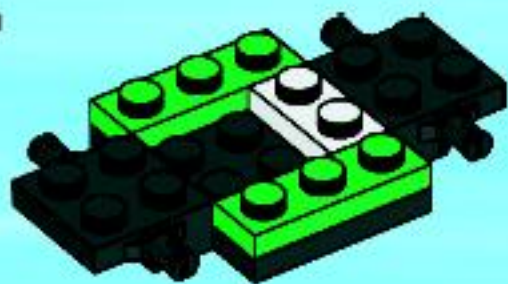

3

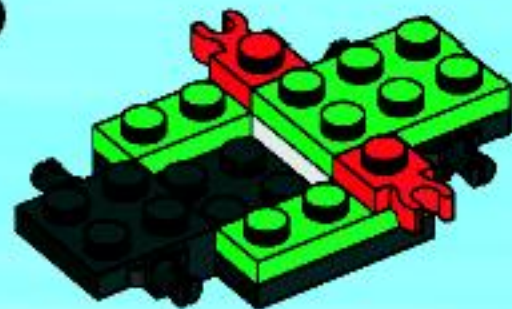



4

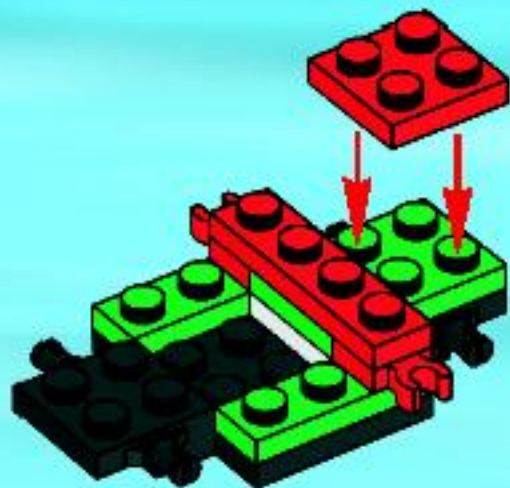

6

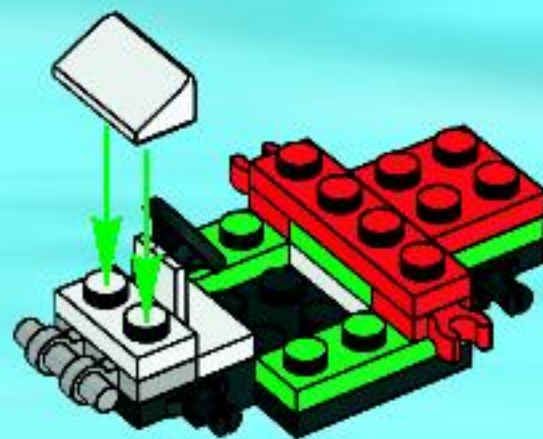

5

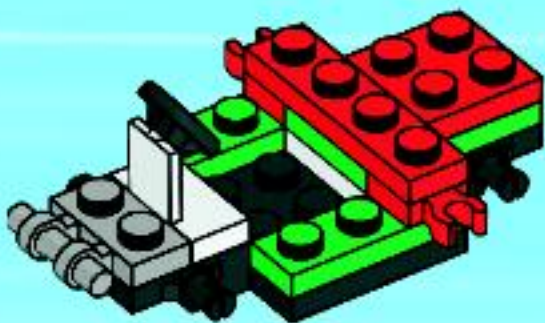

7

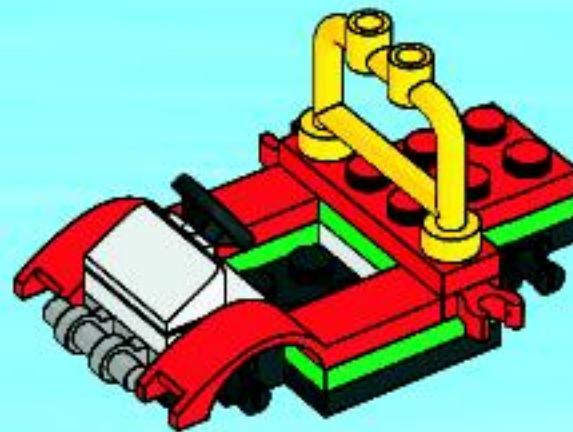

8

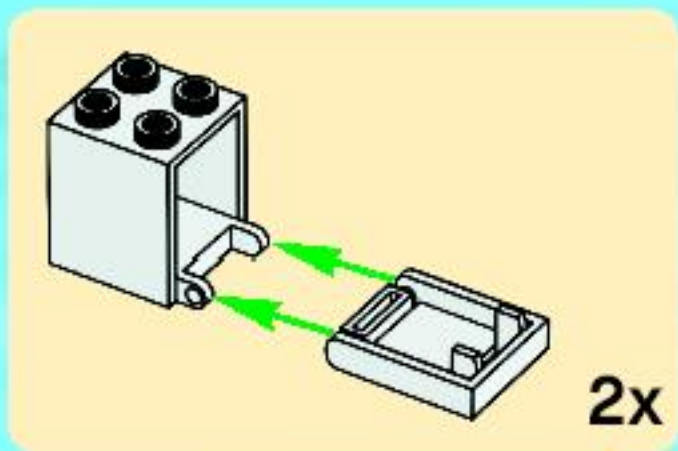
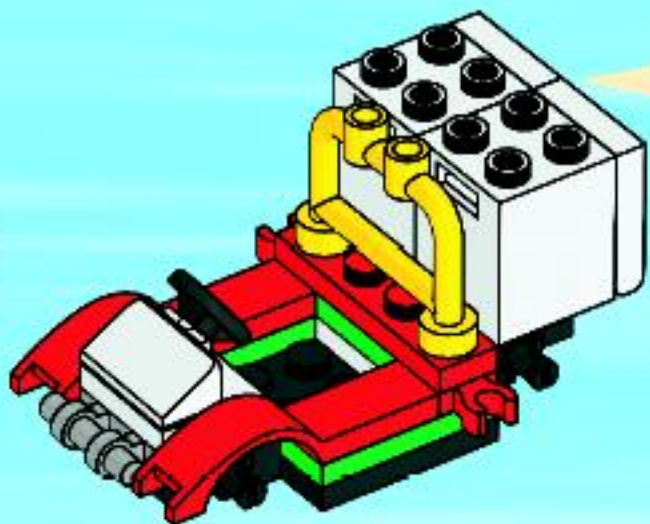

9

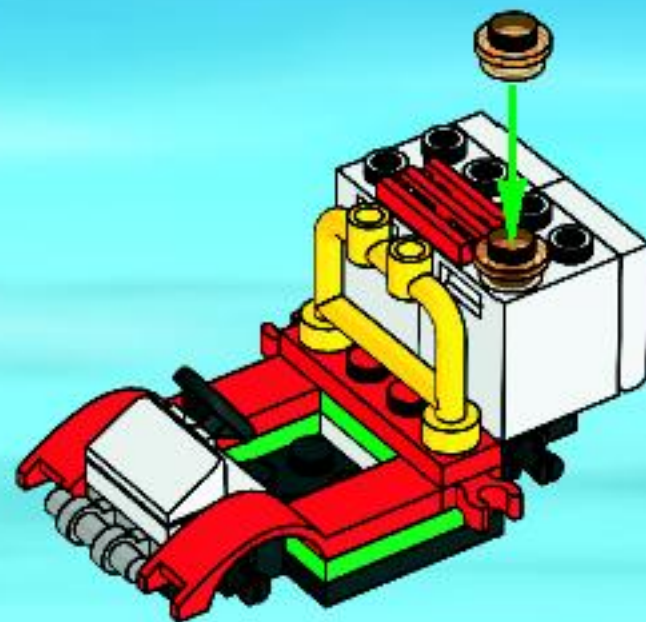

10

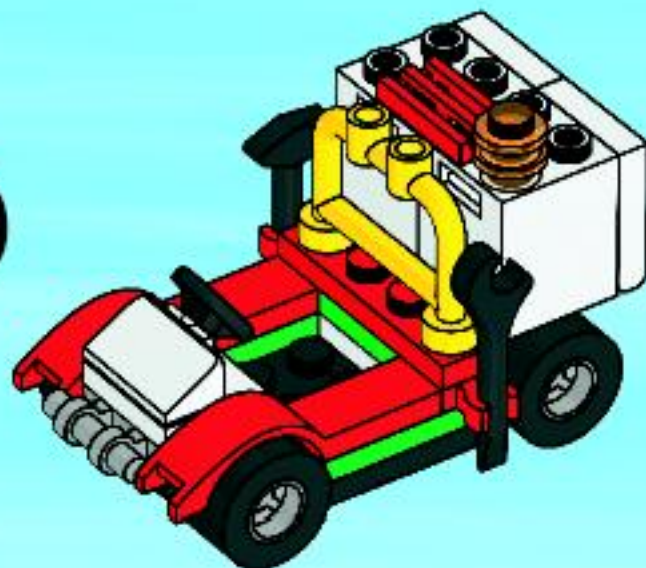



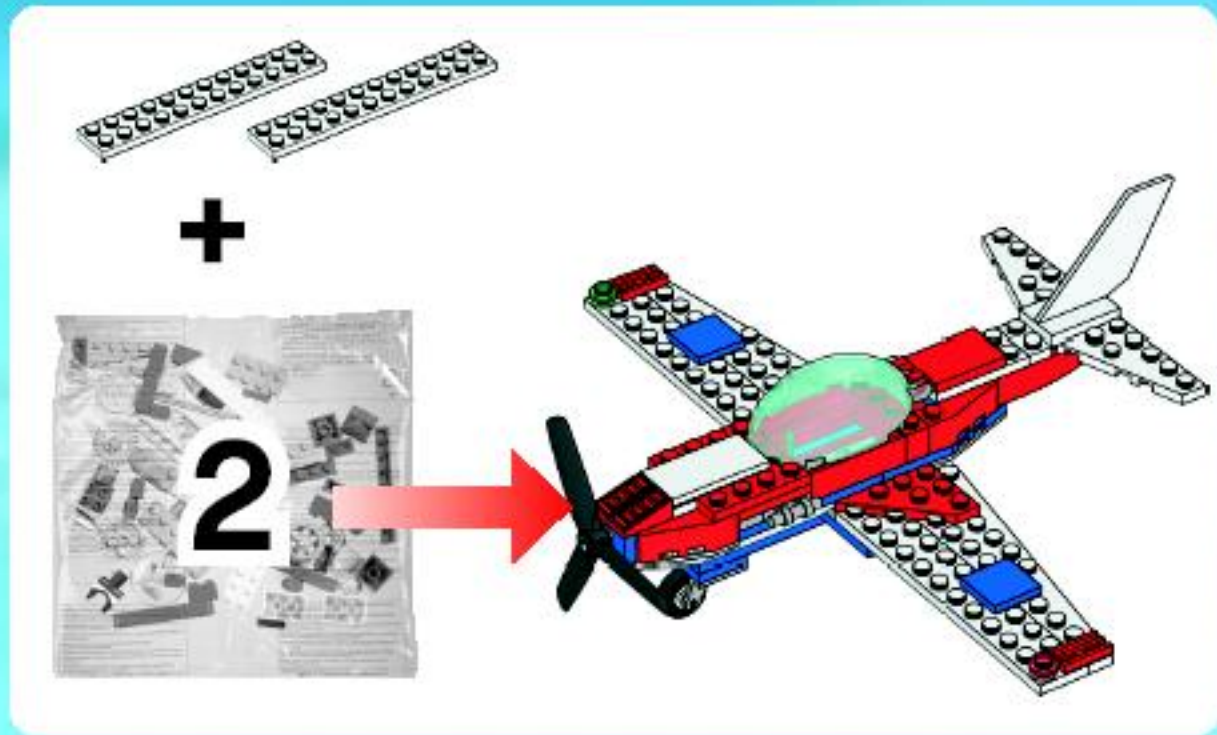

1

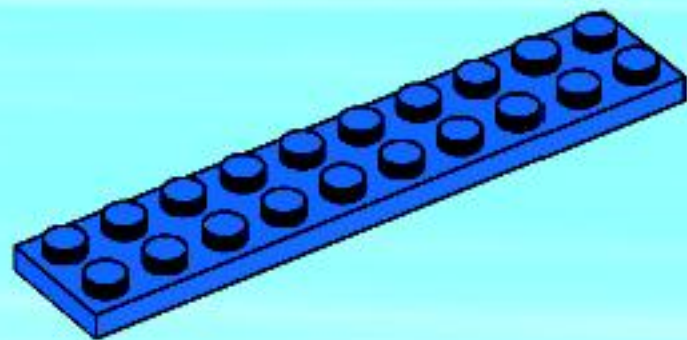

2

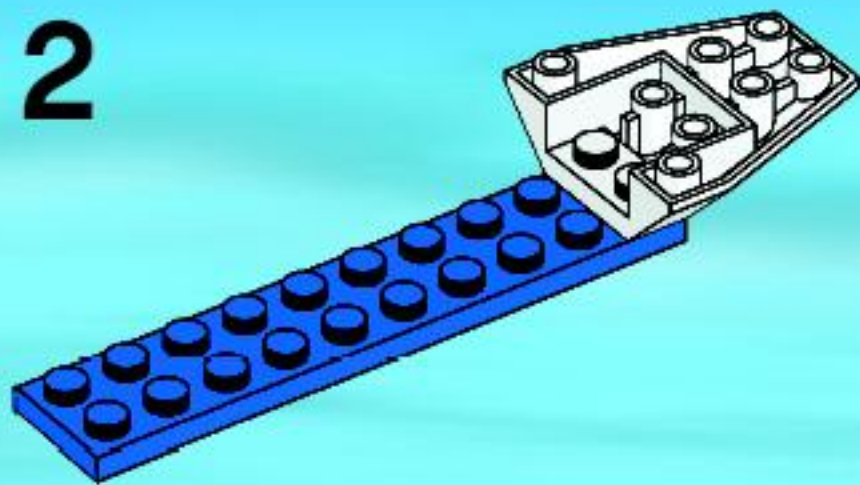

3

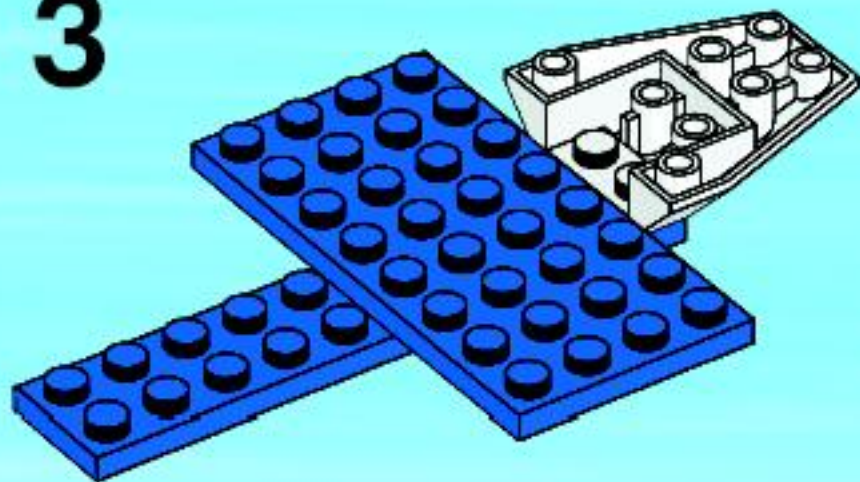



4

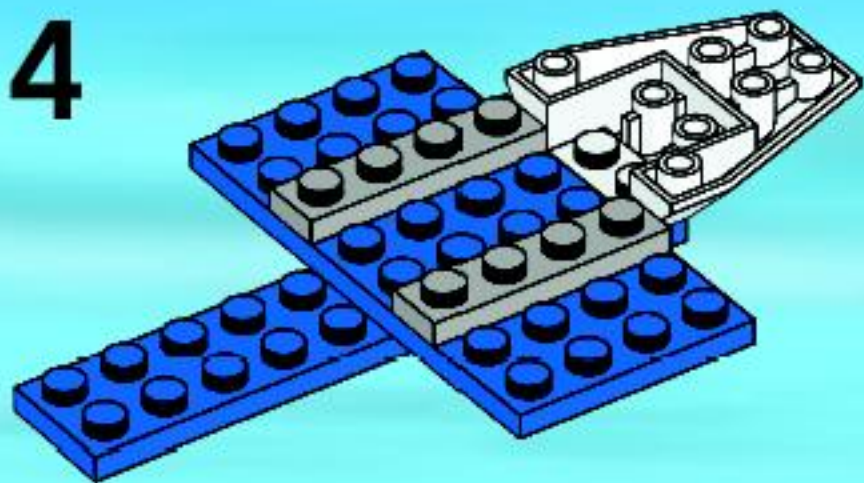

6

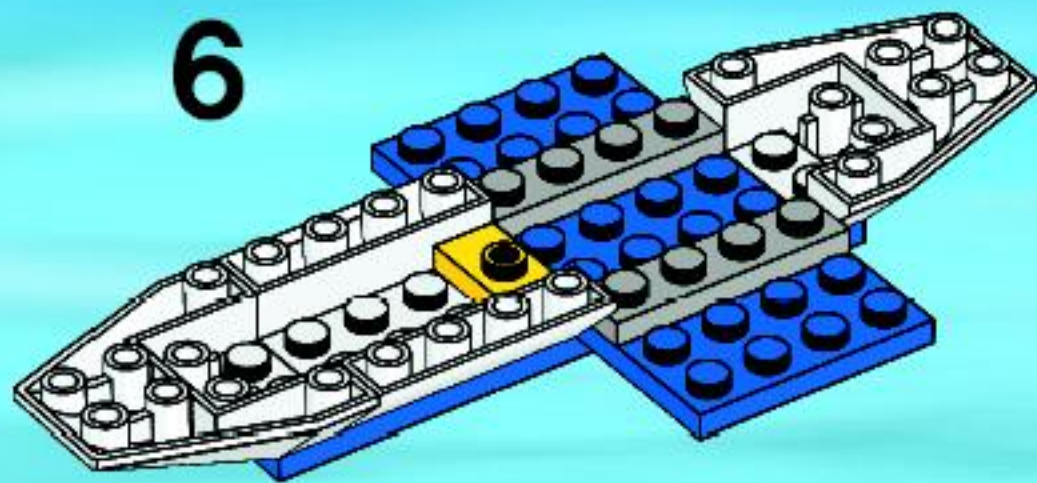

5

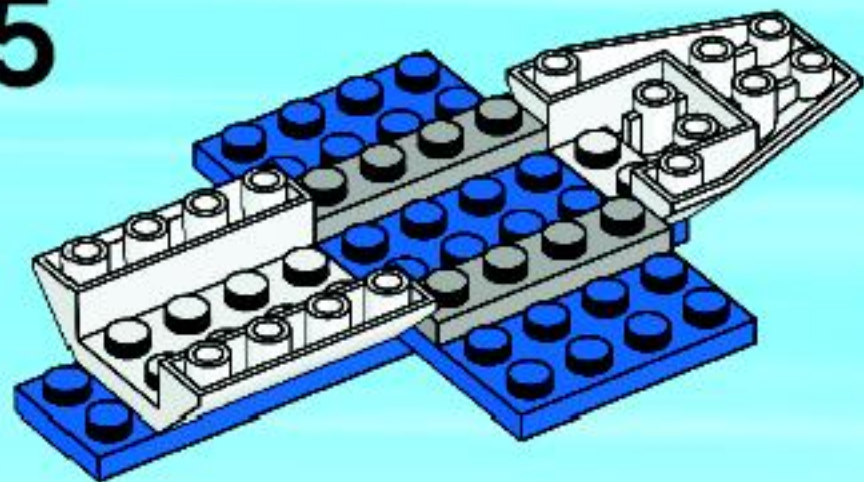

7

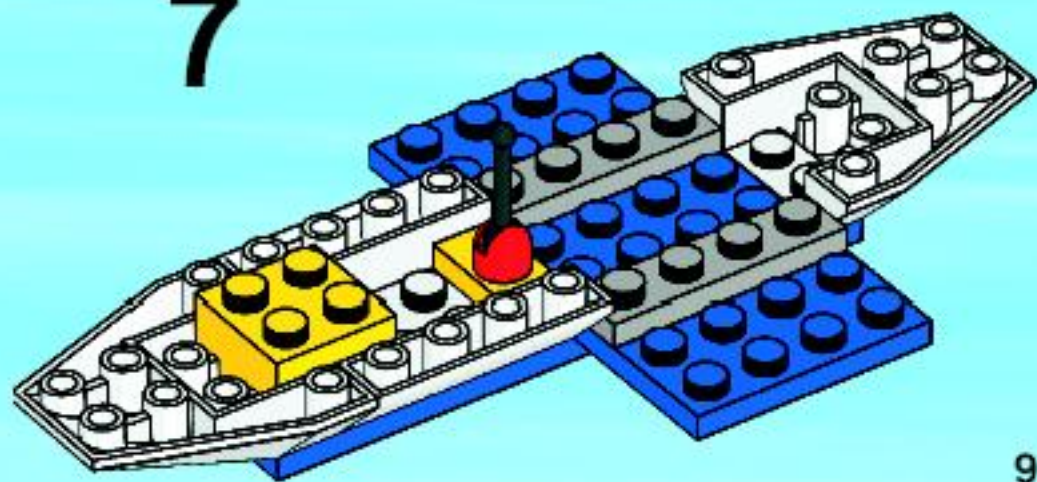

1

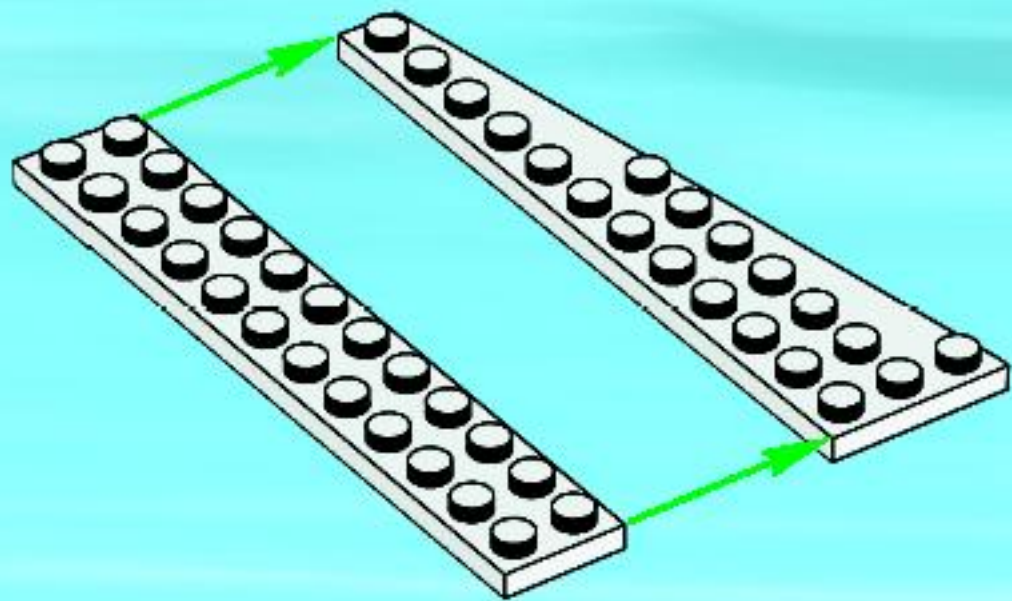

2

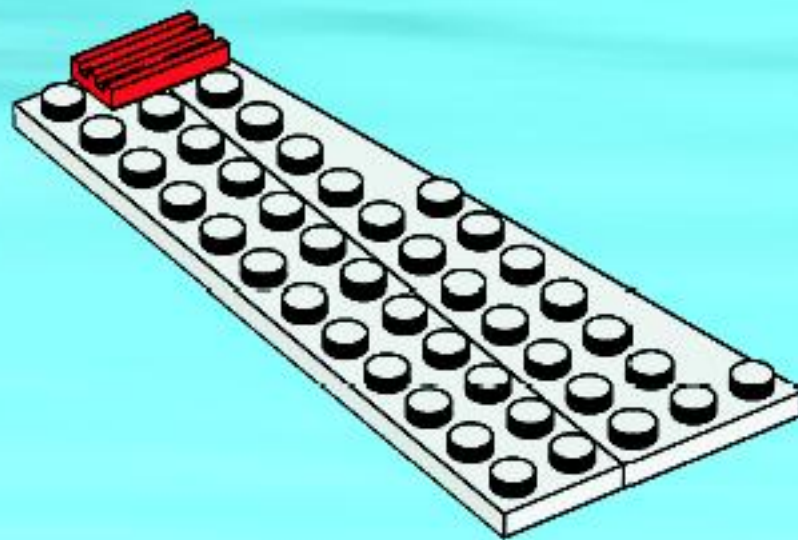



3

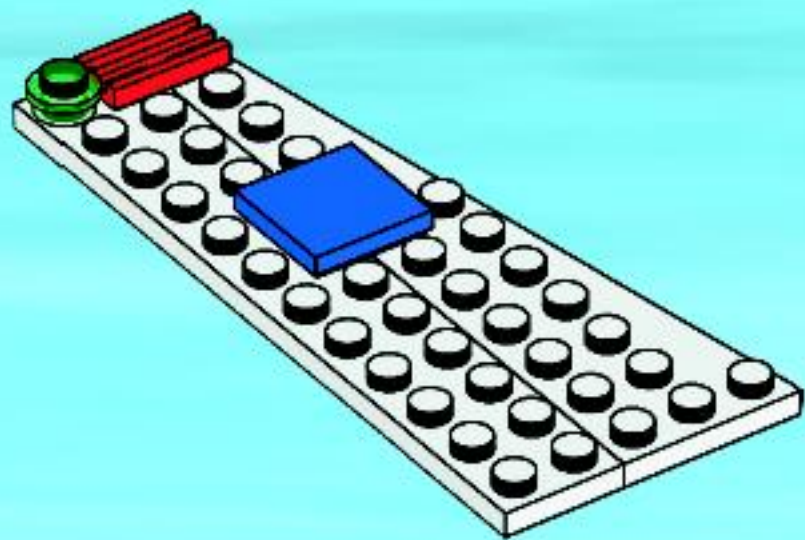

8

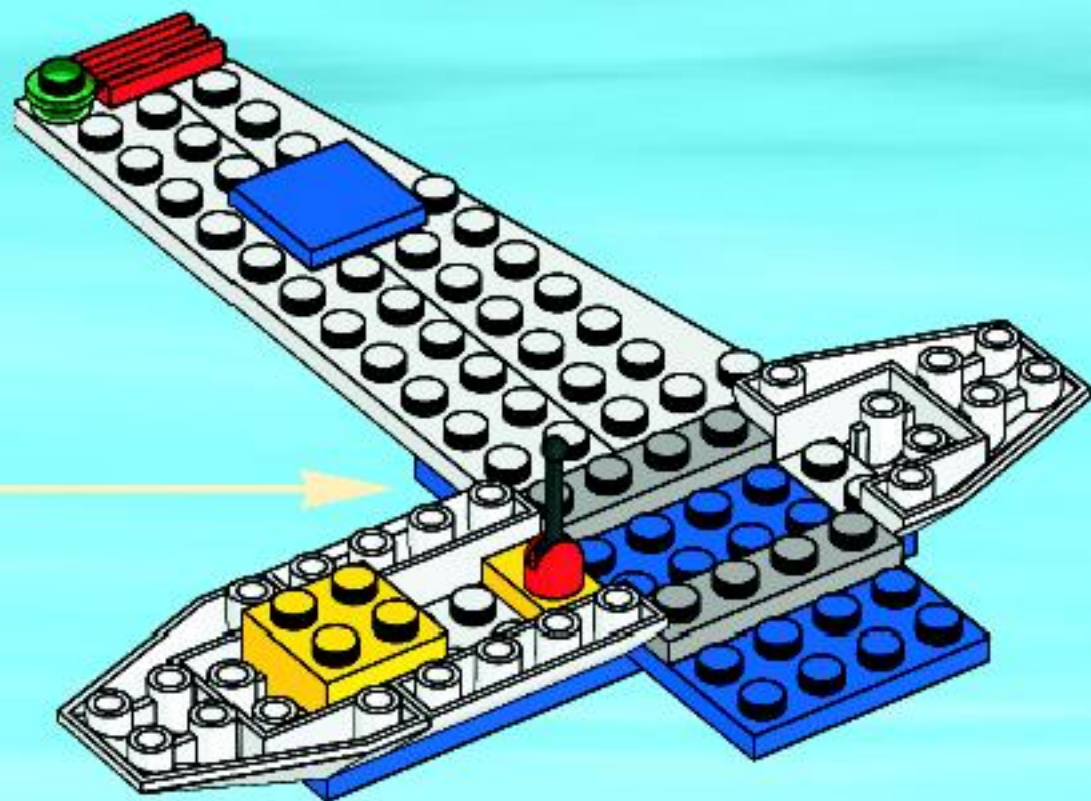

1

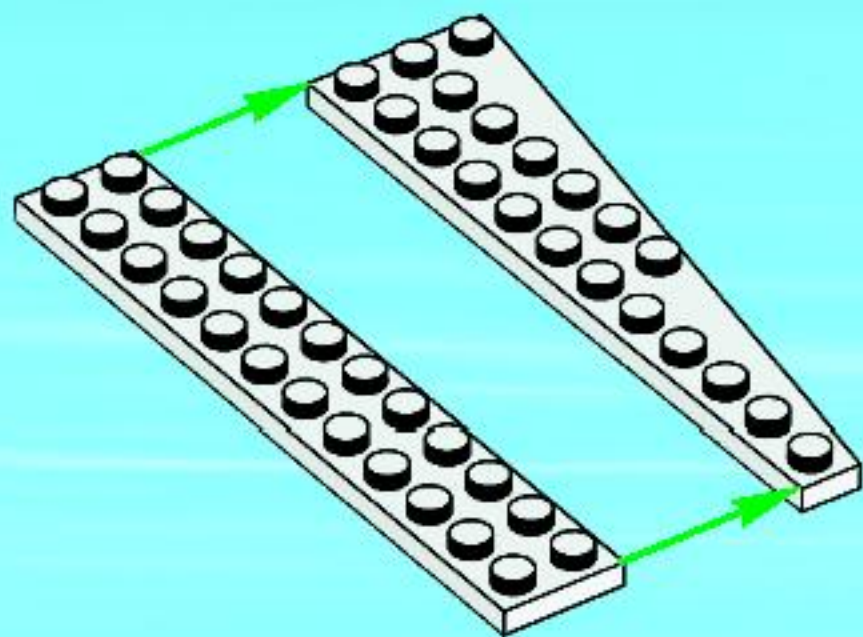

2

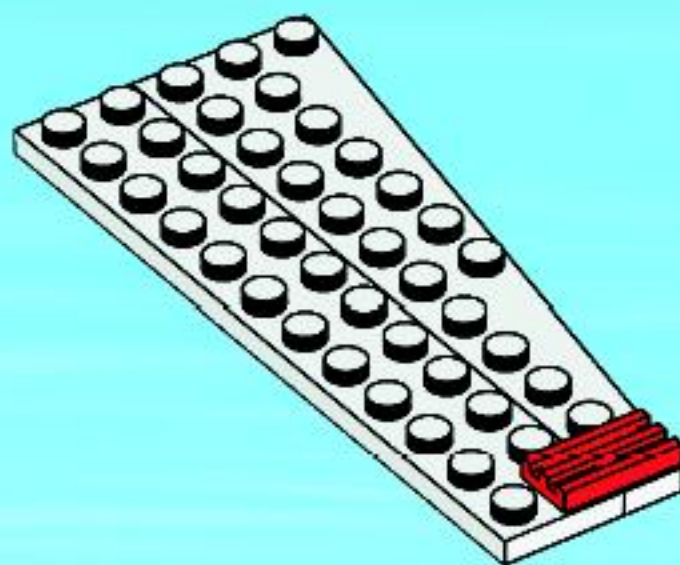



3

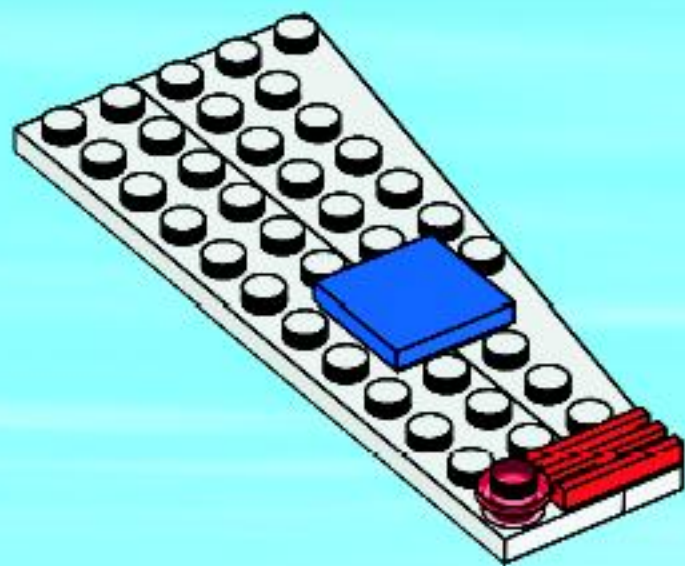

9

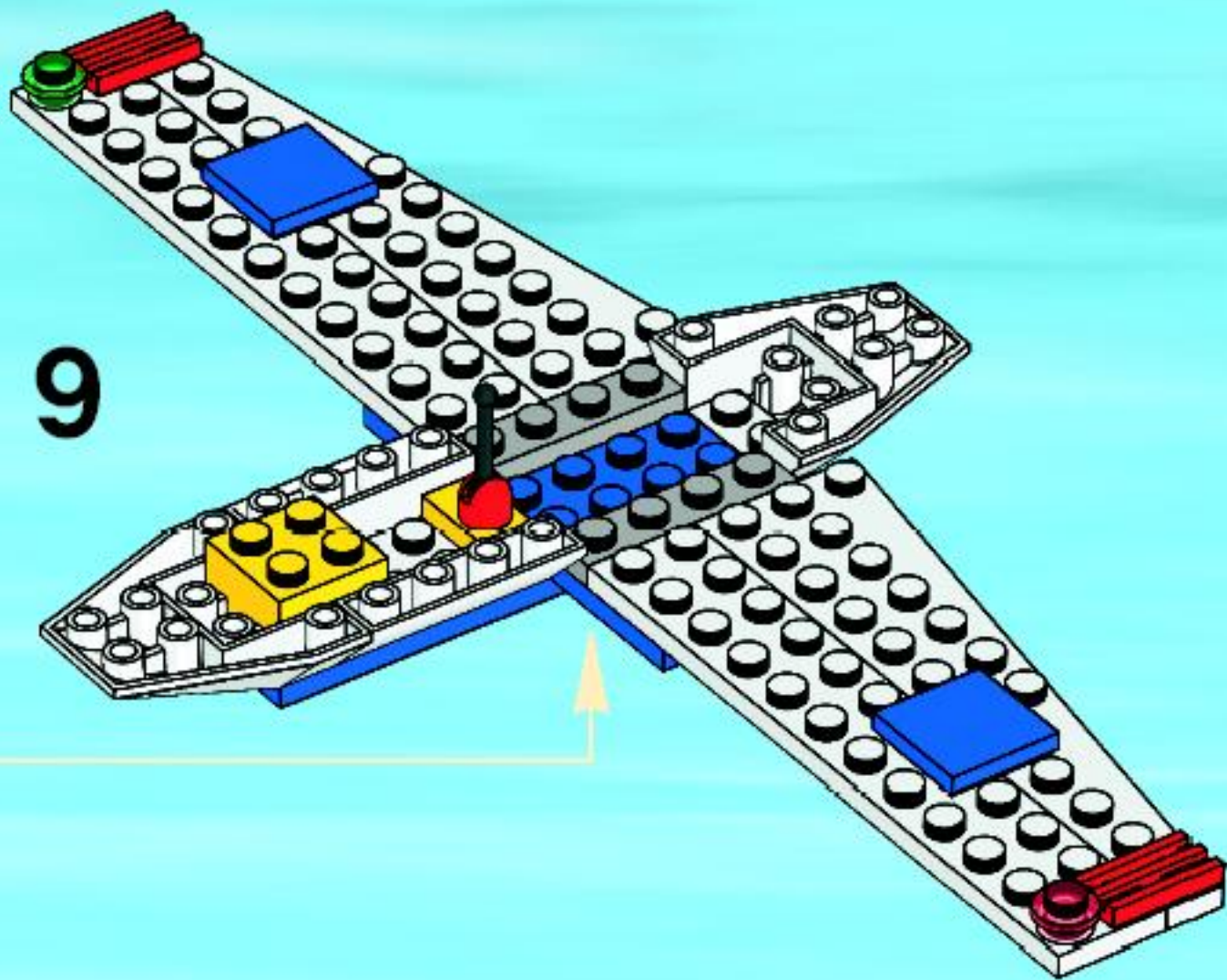

10

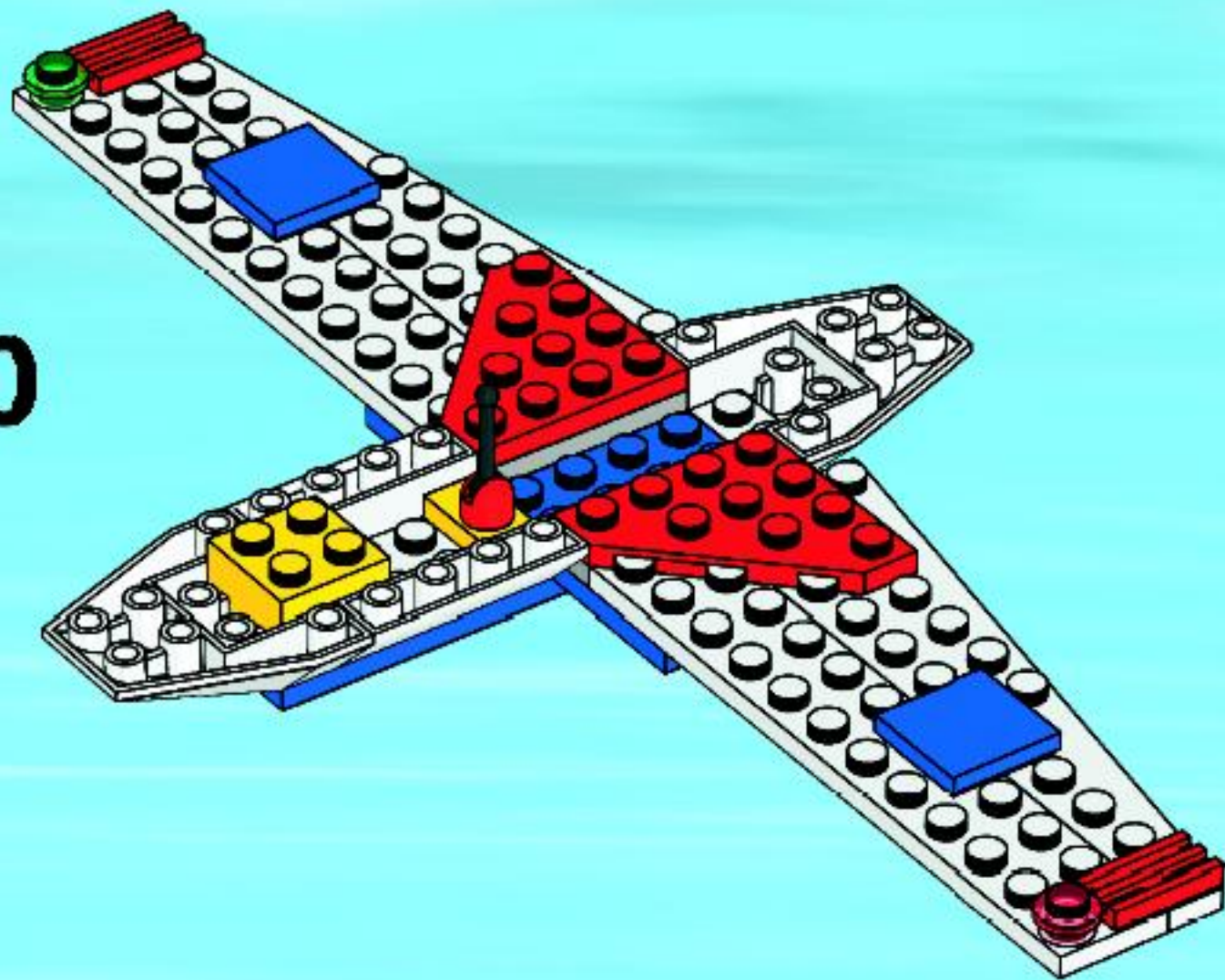



11

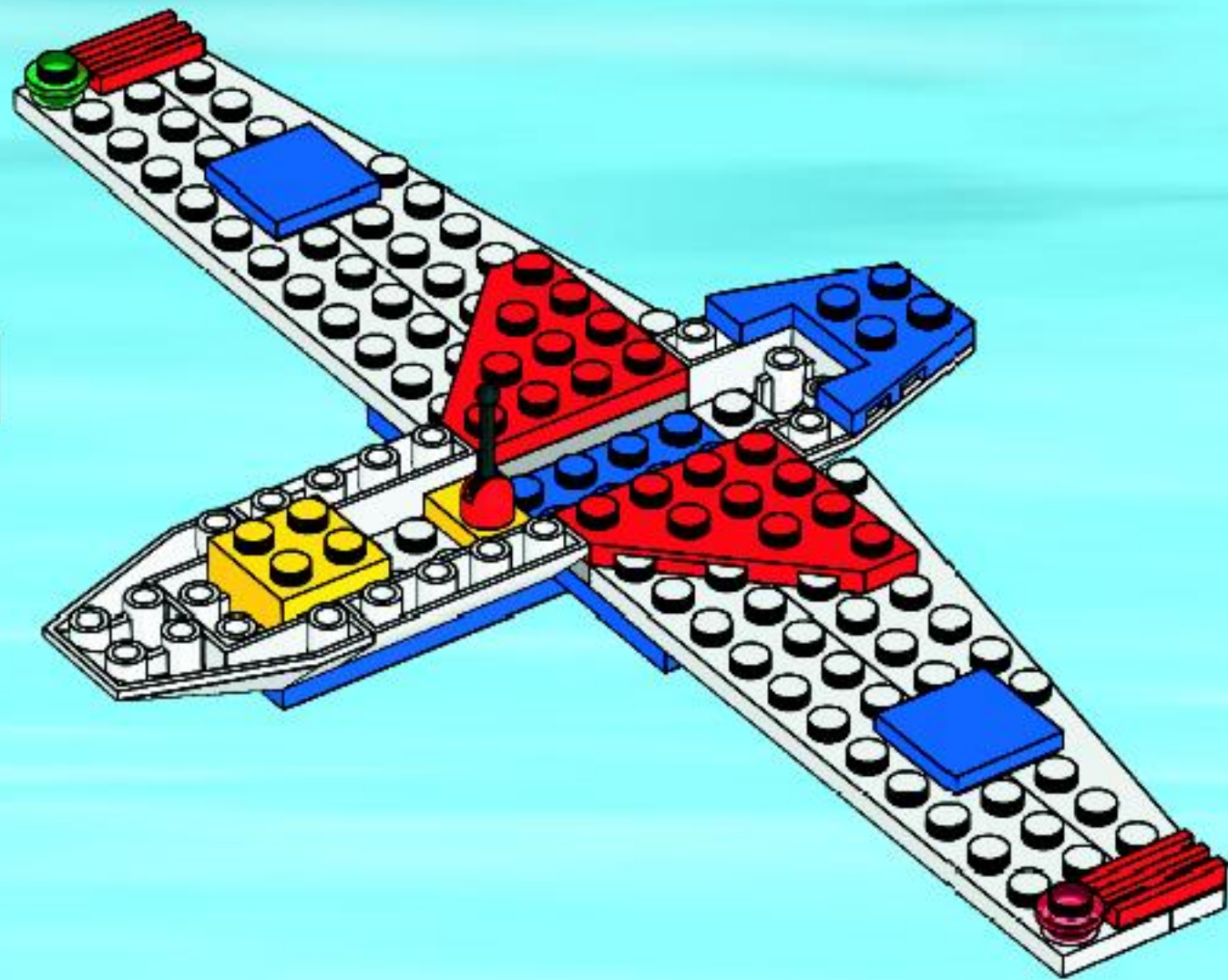

12

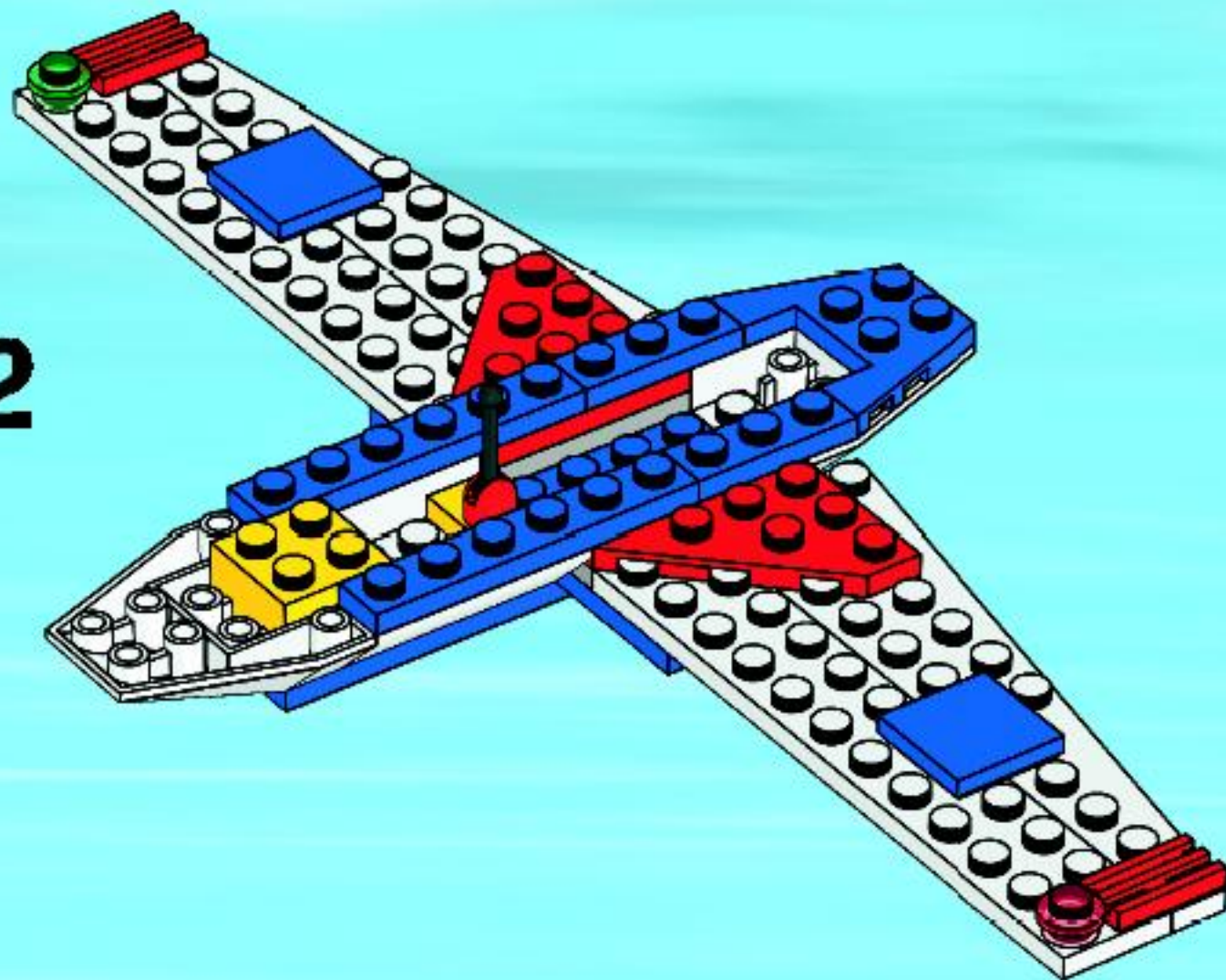



13

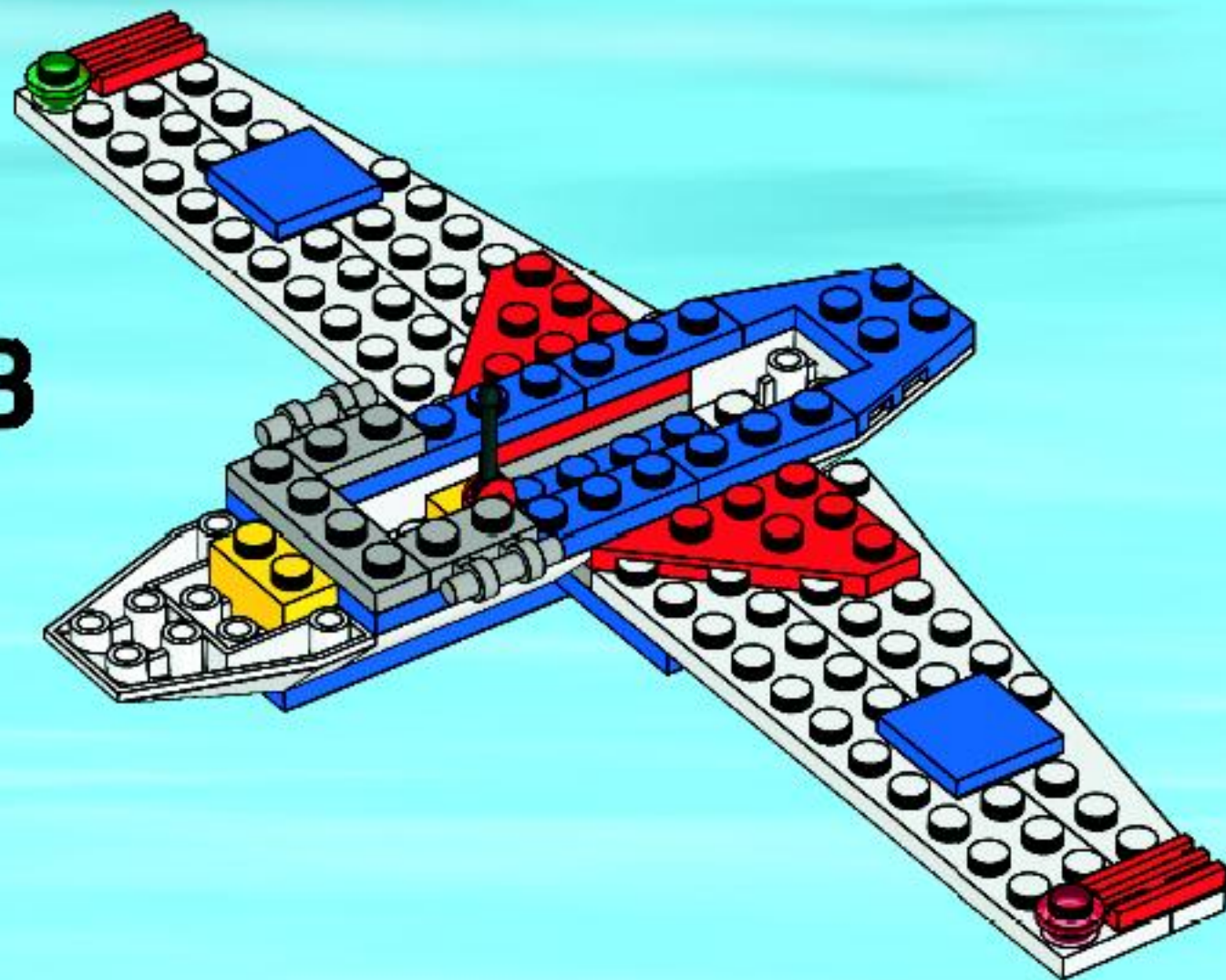

14

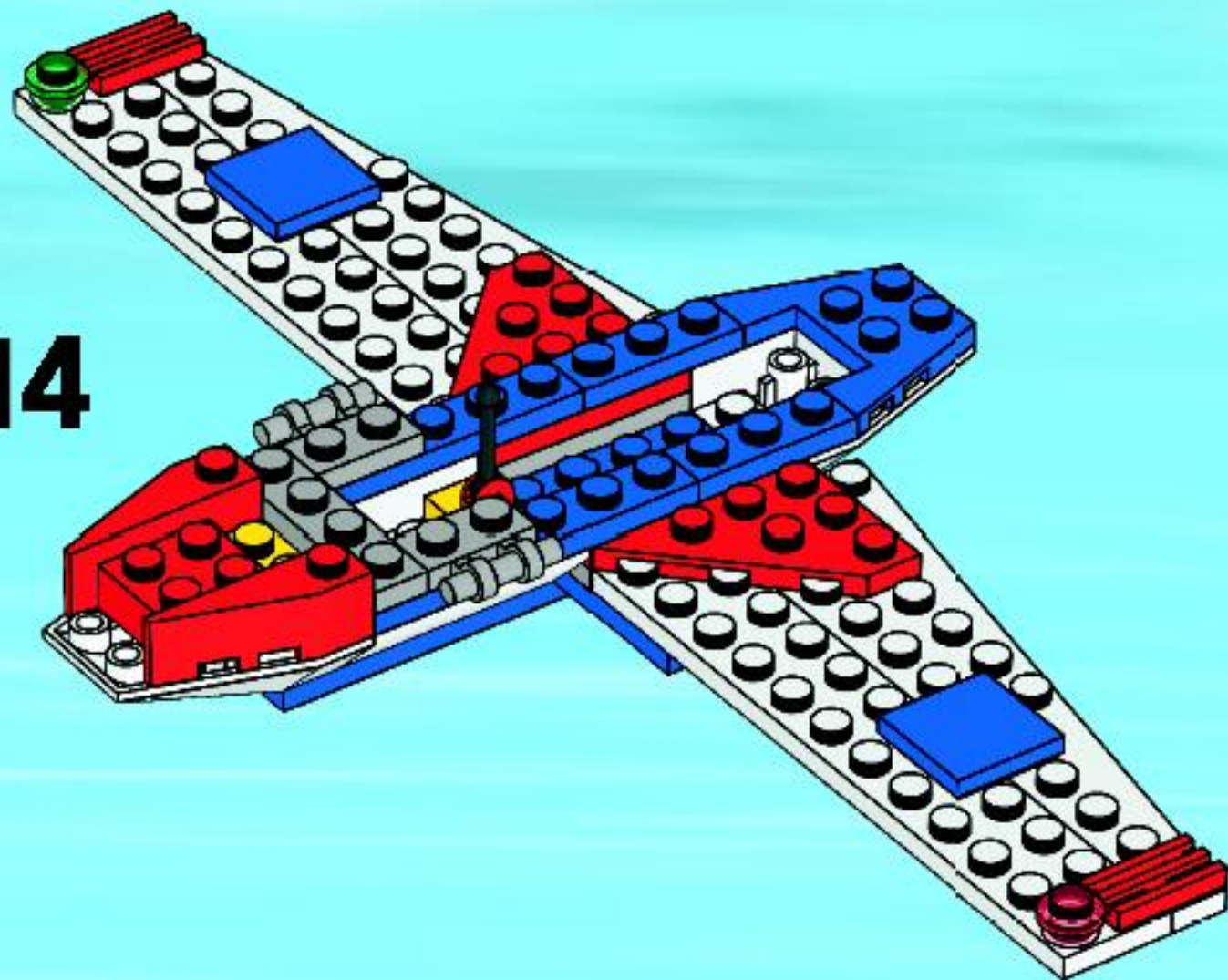



15

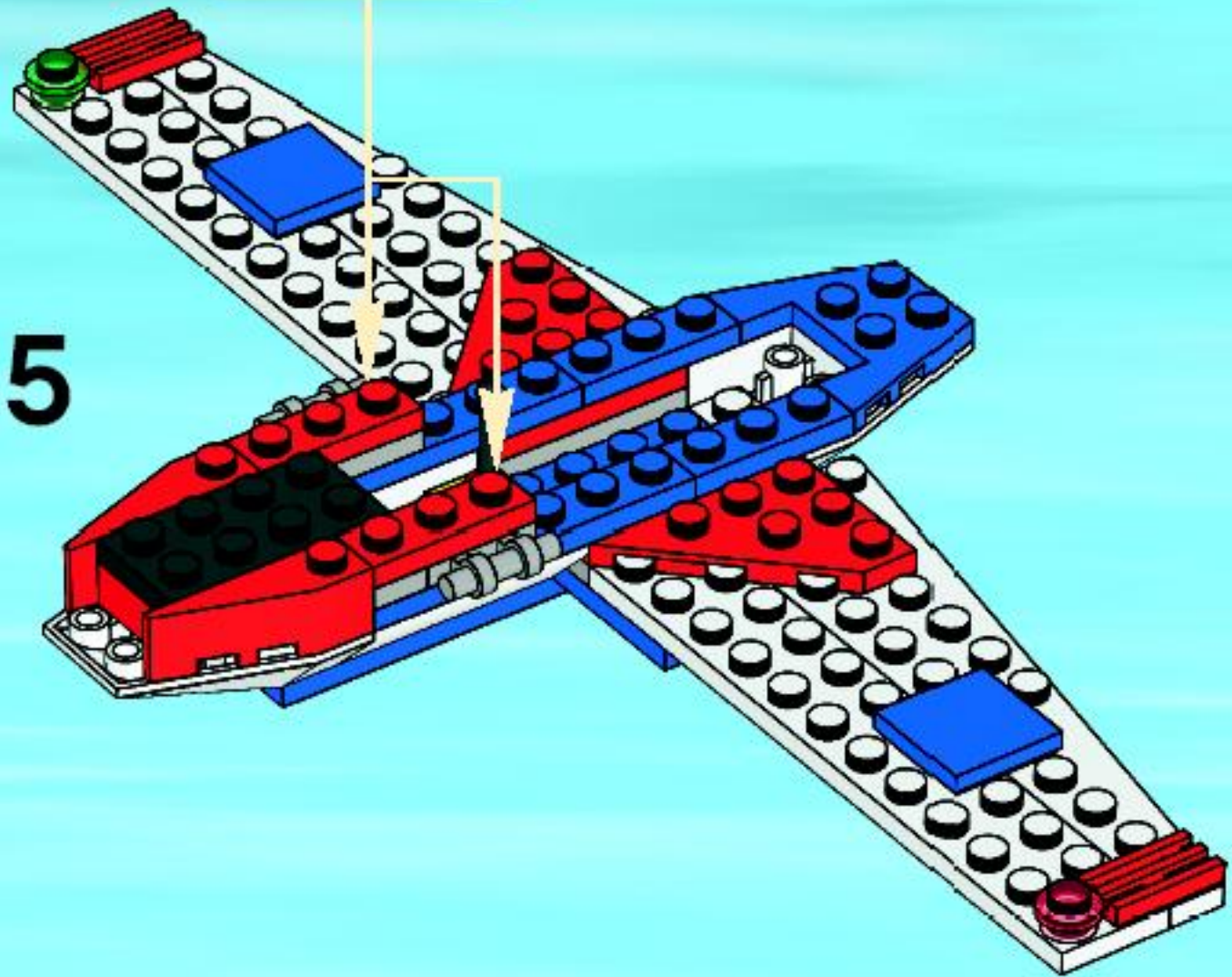

16

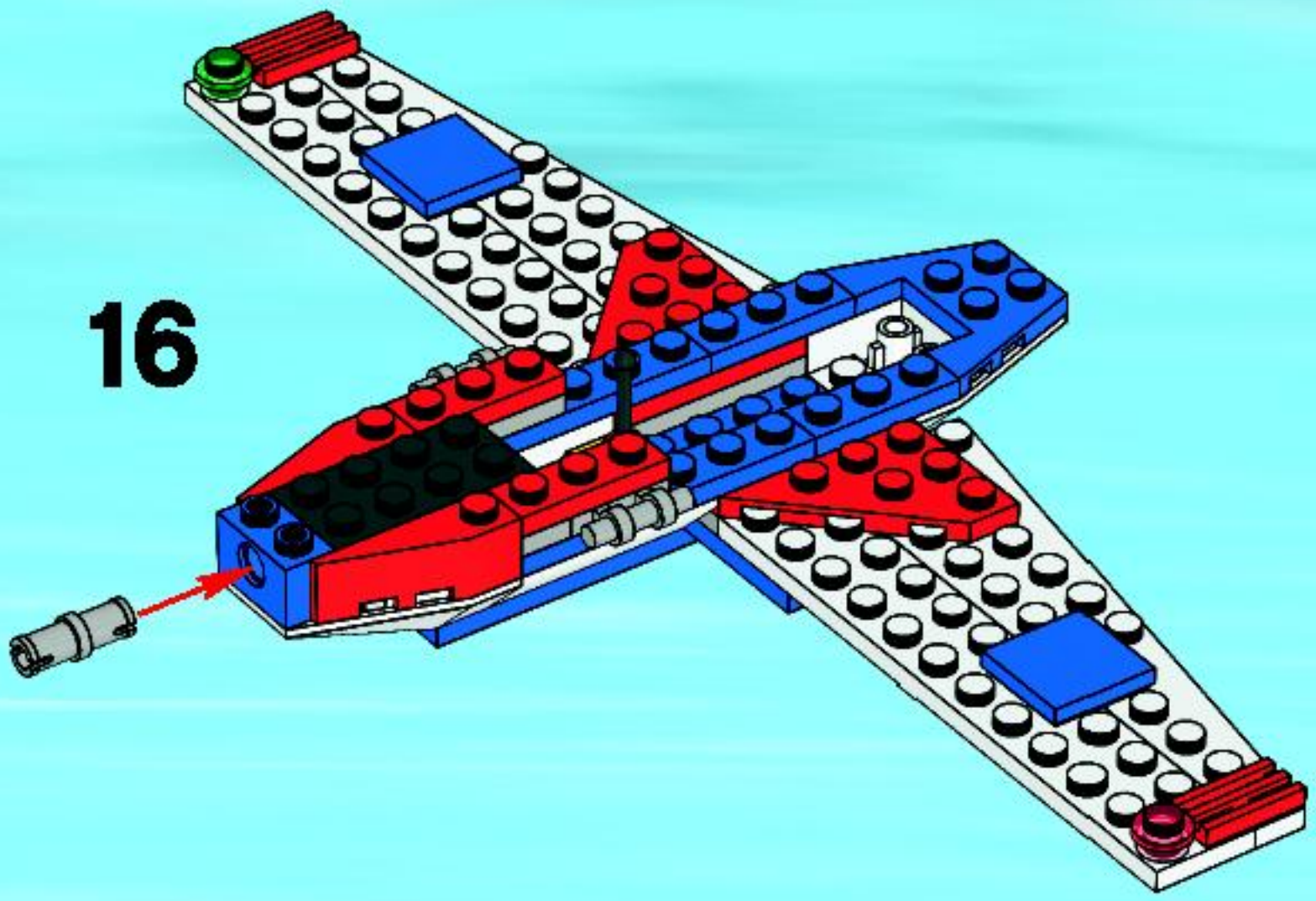



17

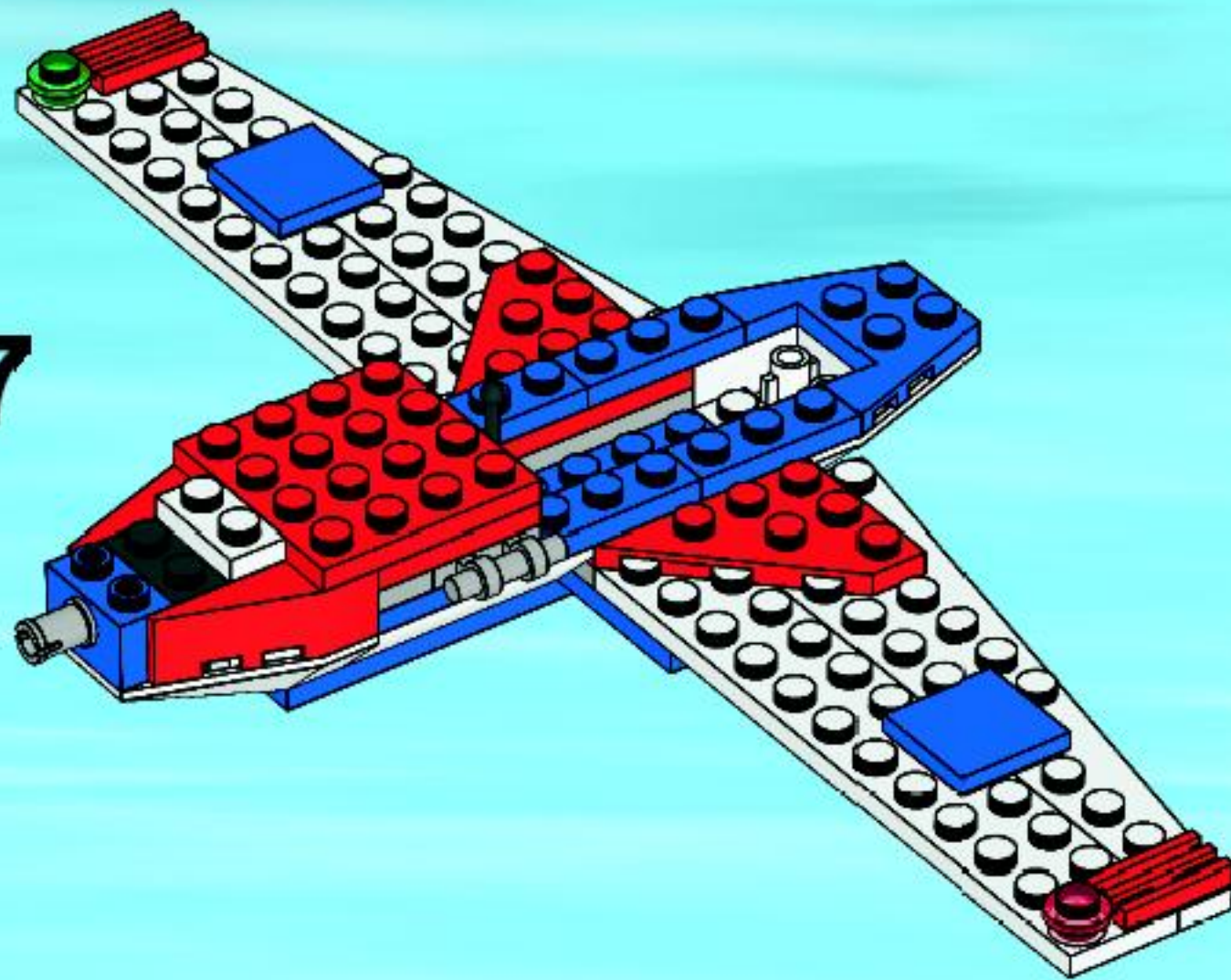

18

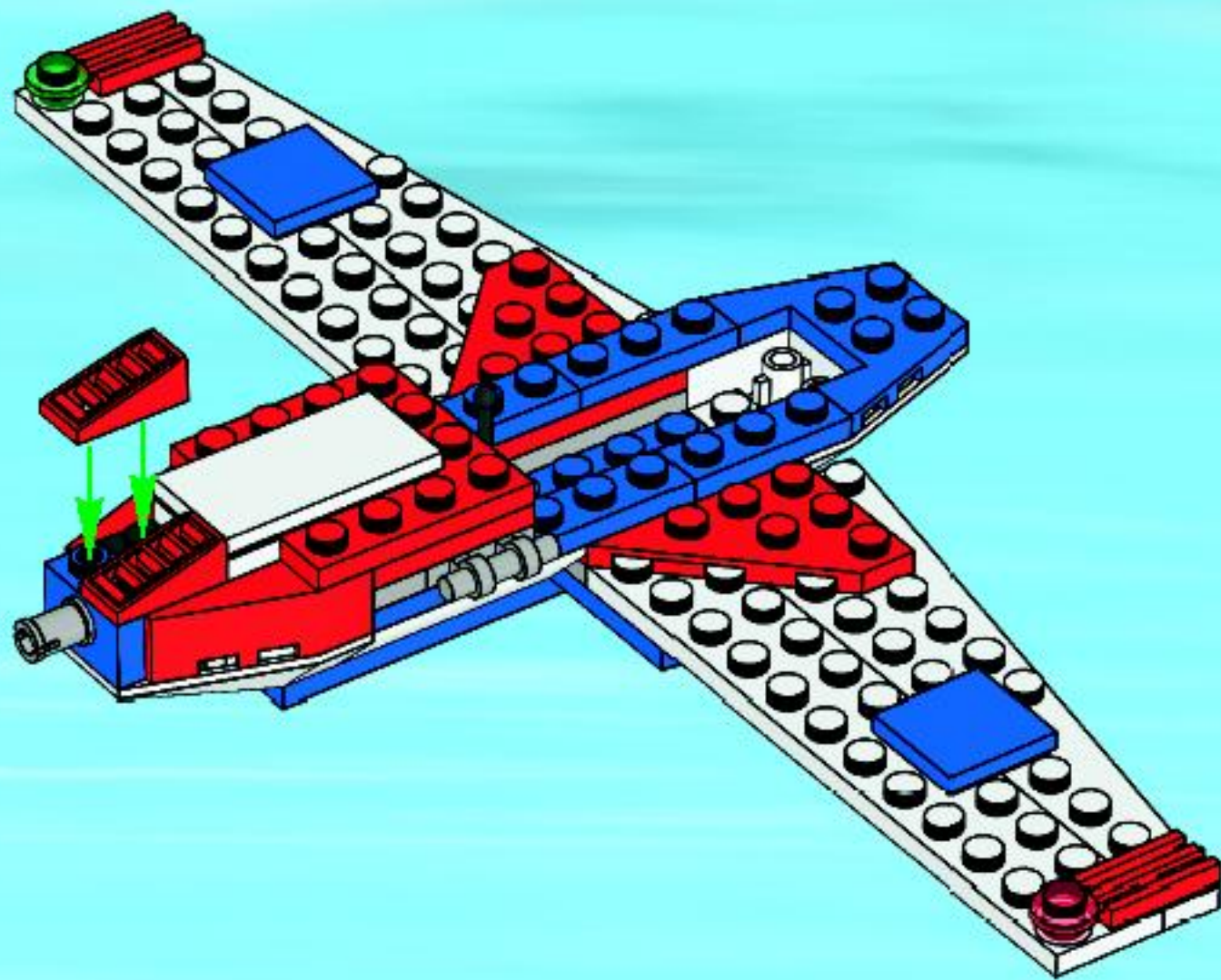



19

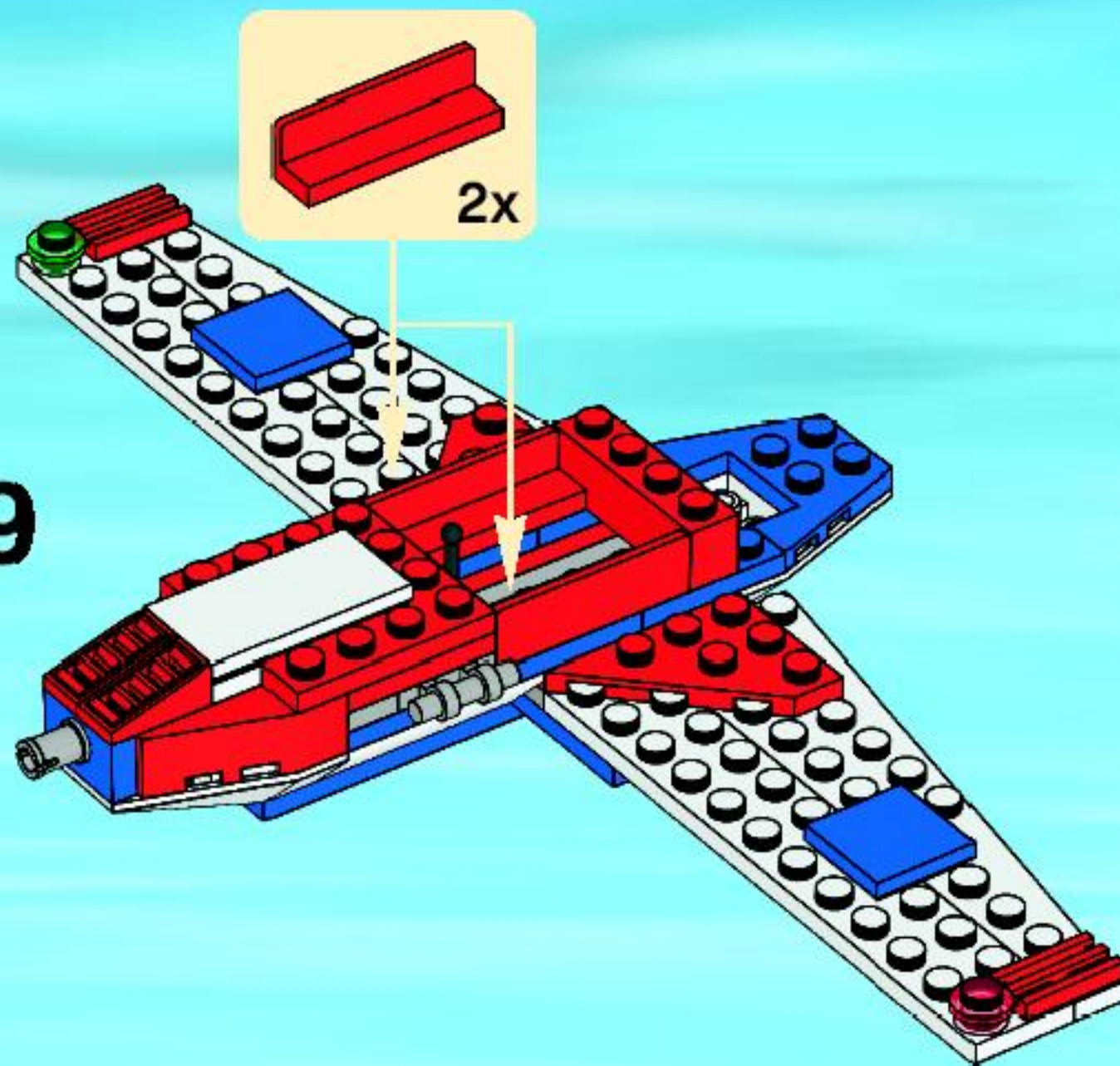

20

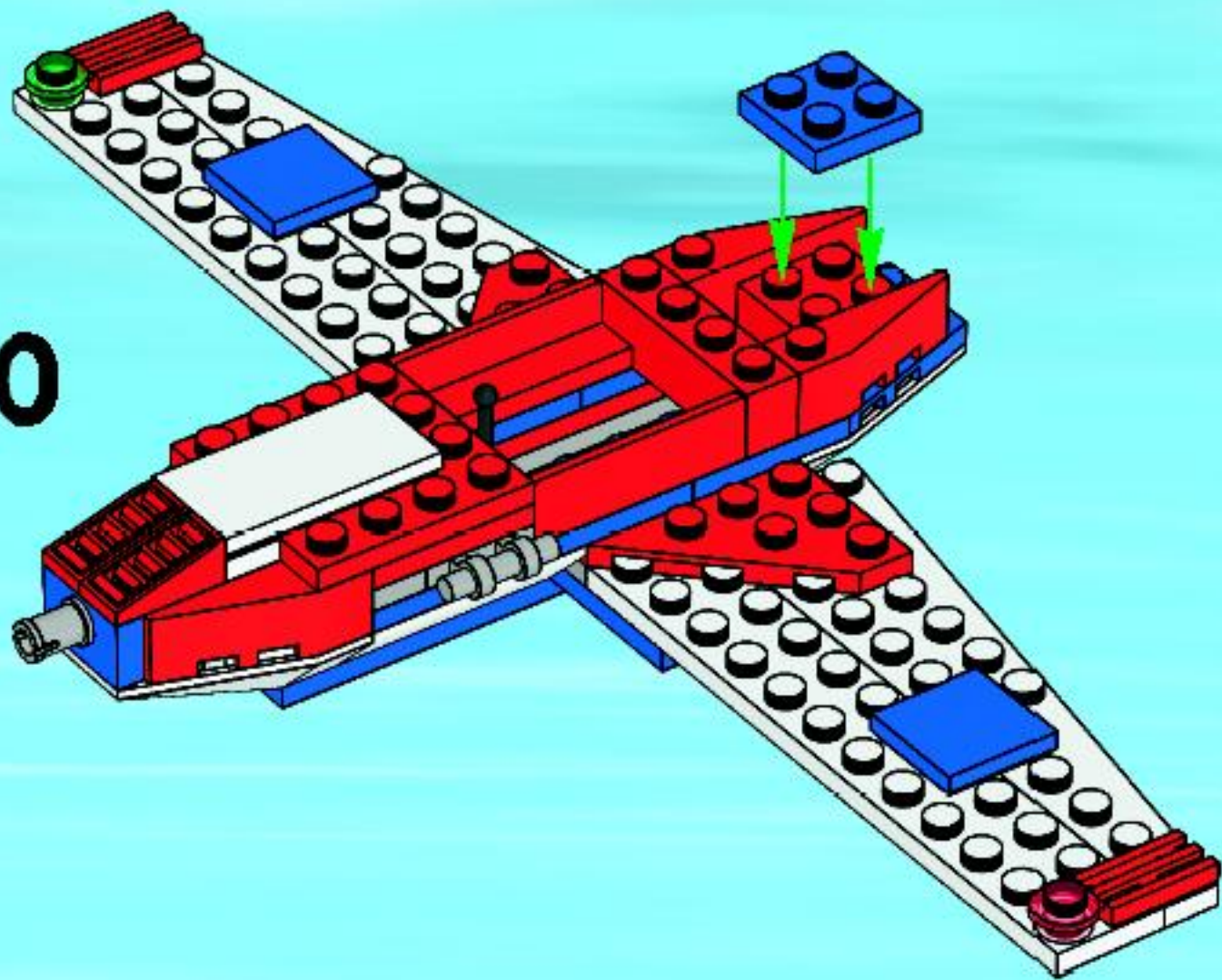



21

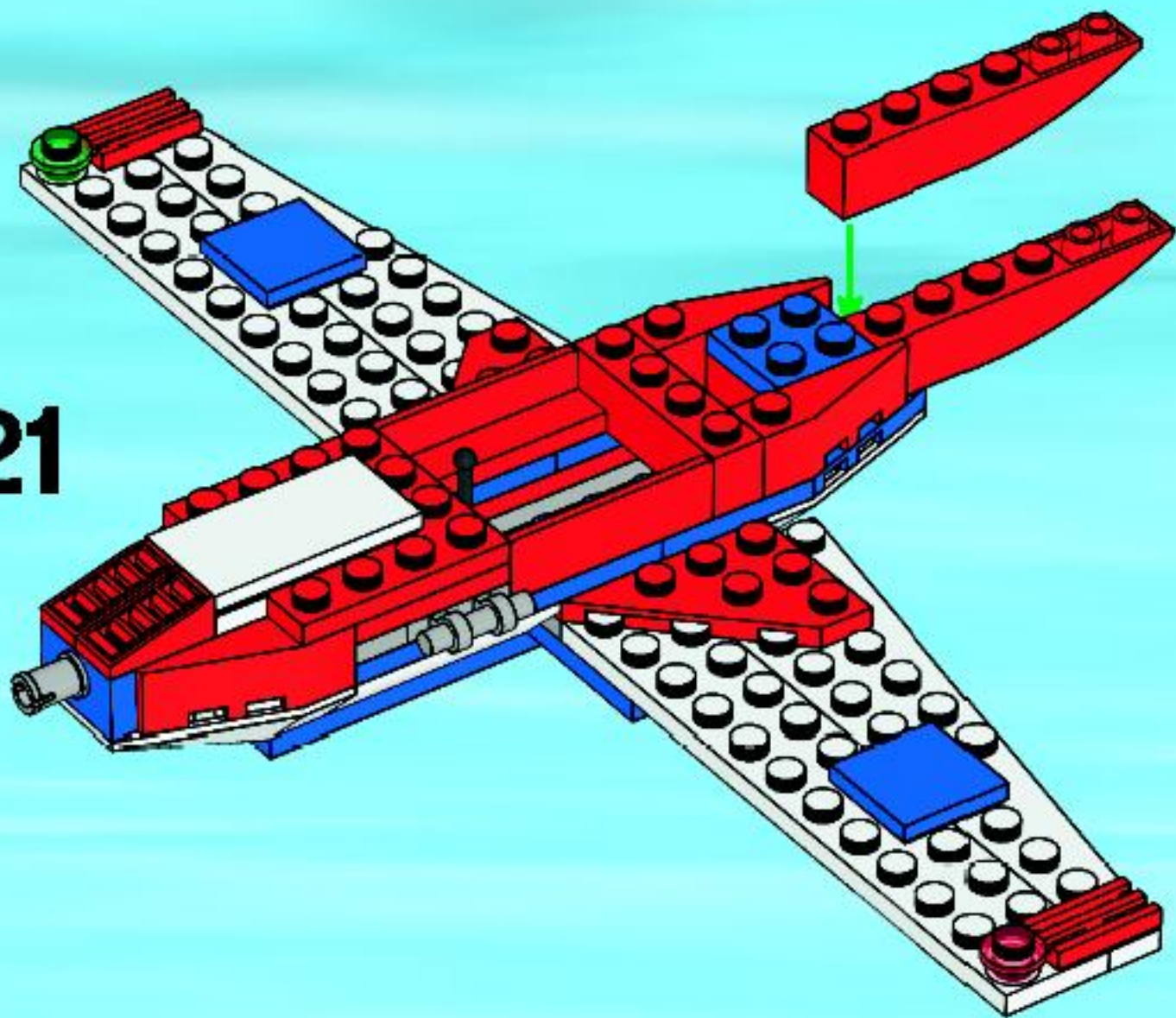

22

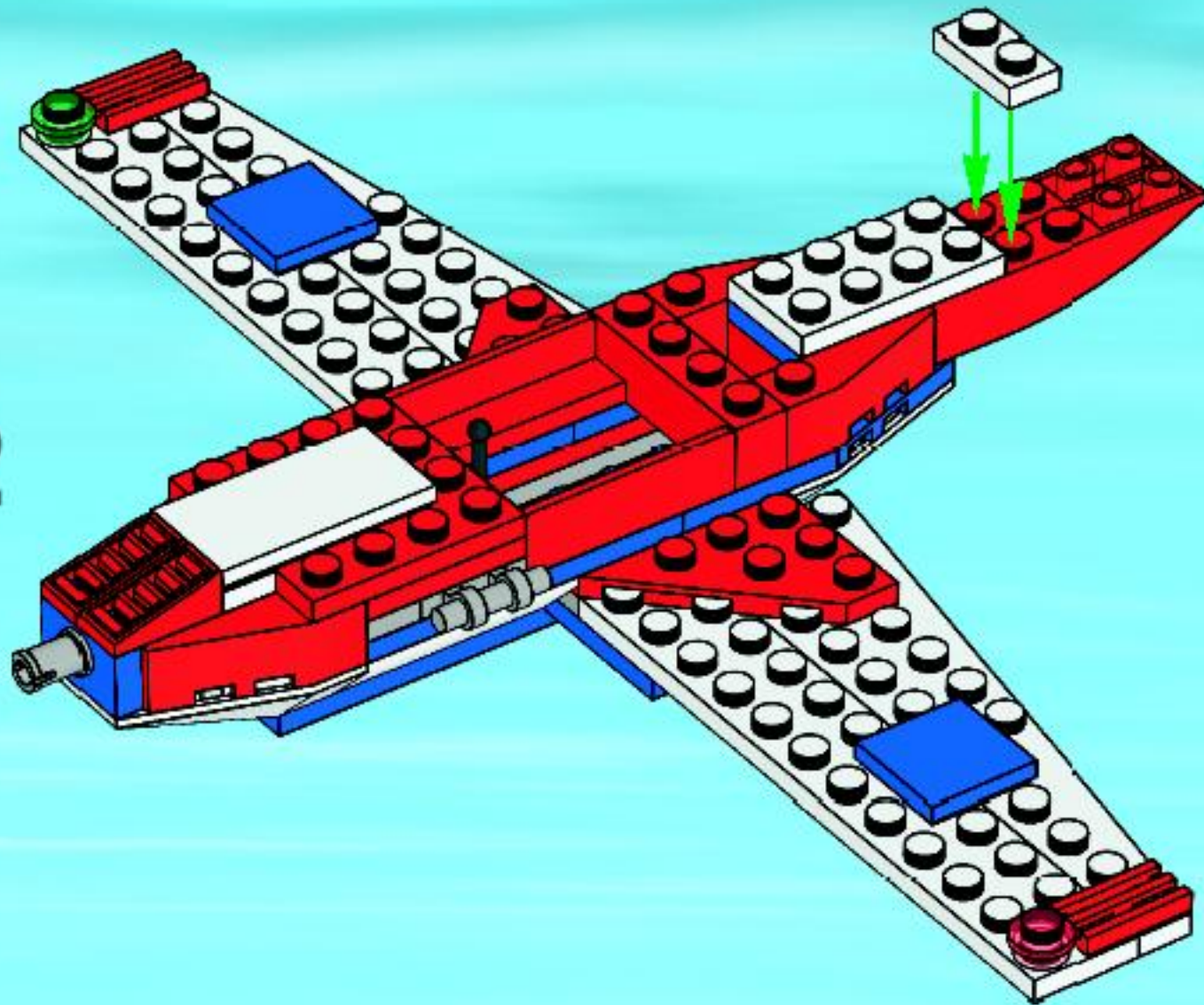



23

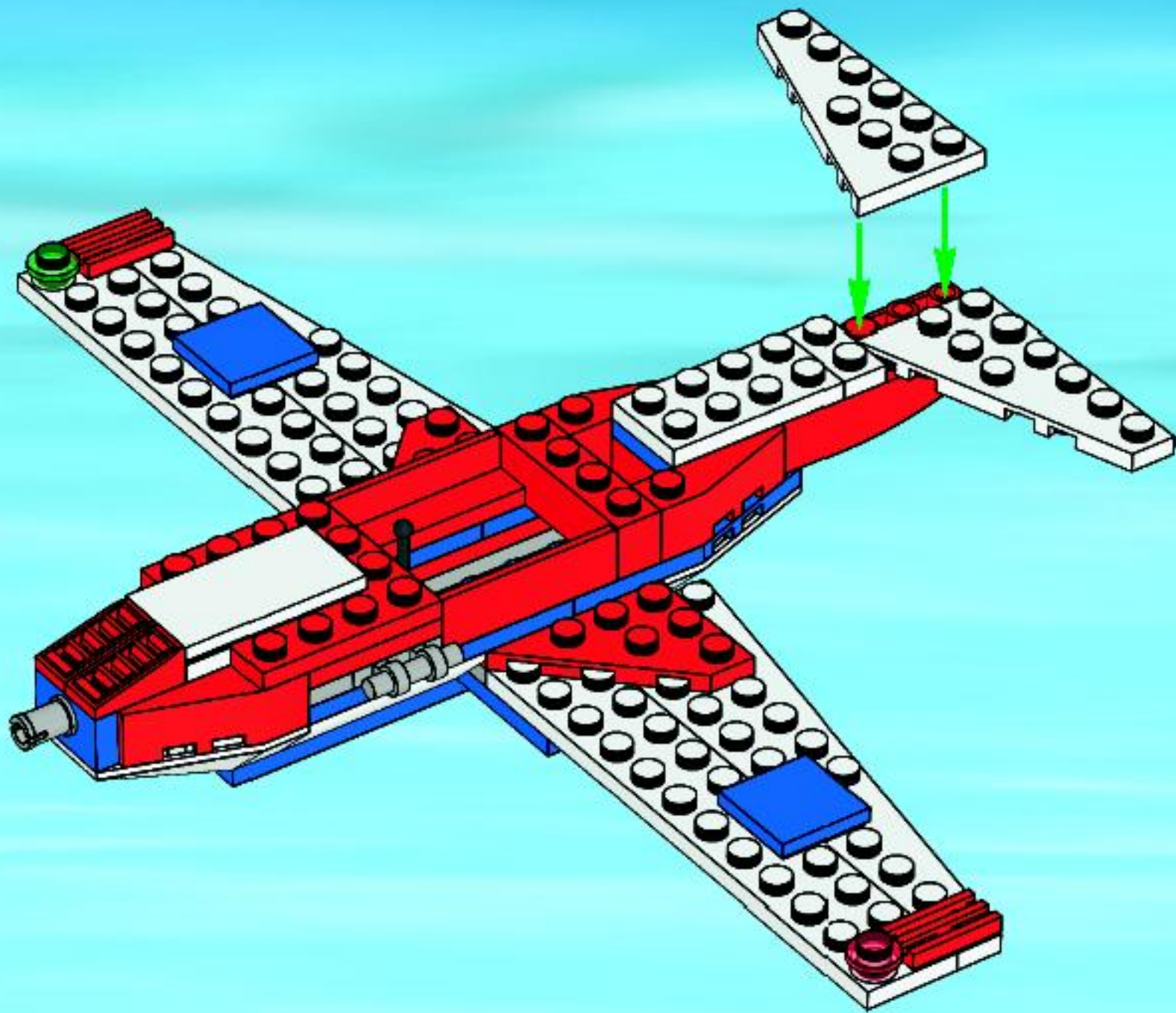

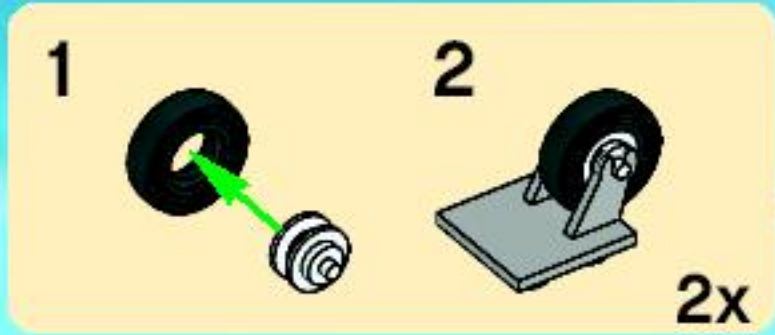

24

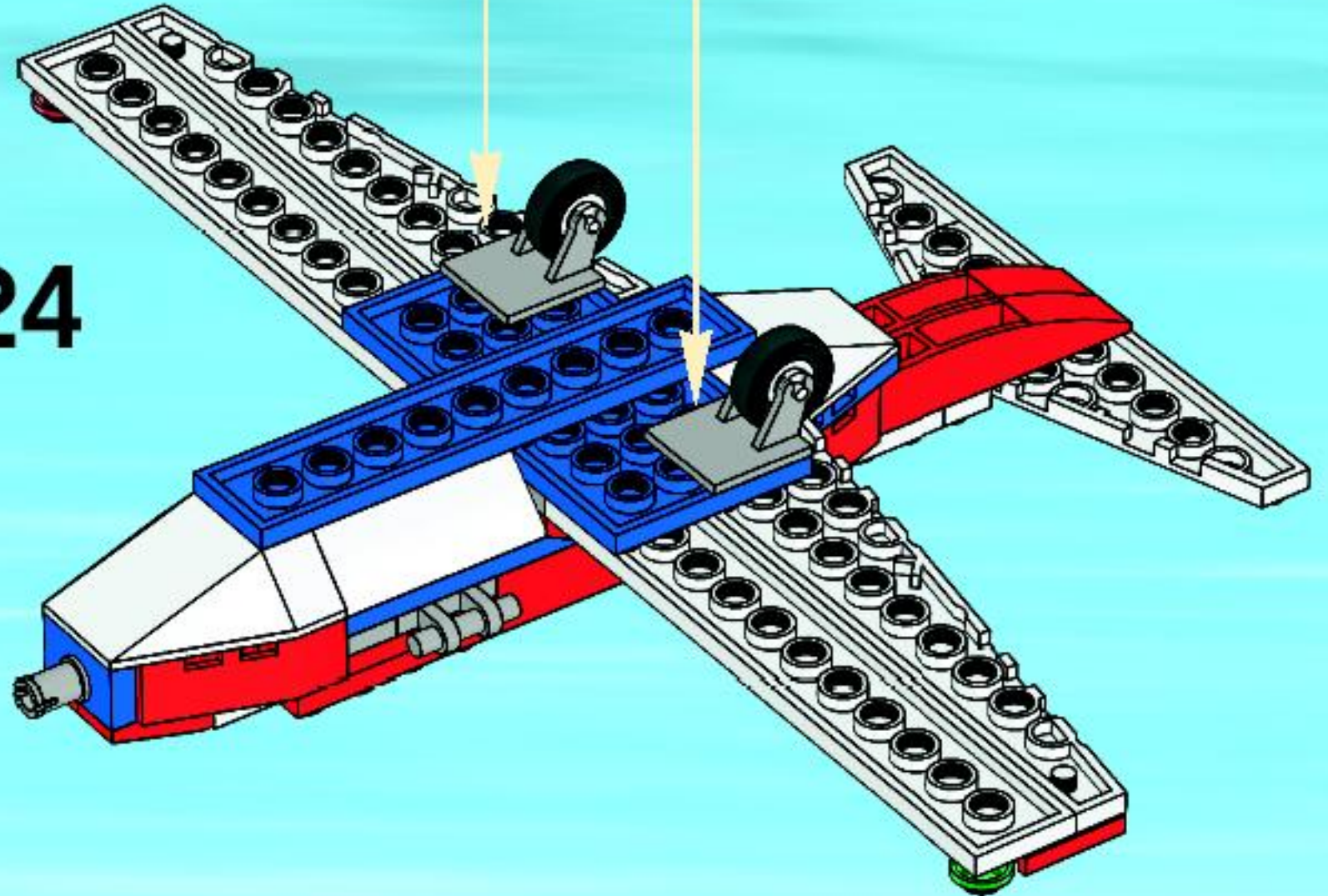



1



2



25

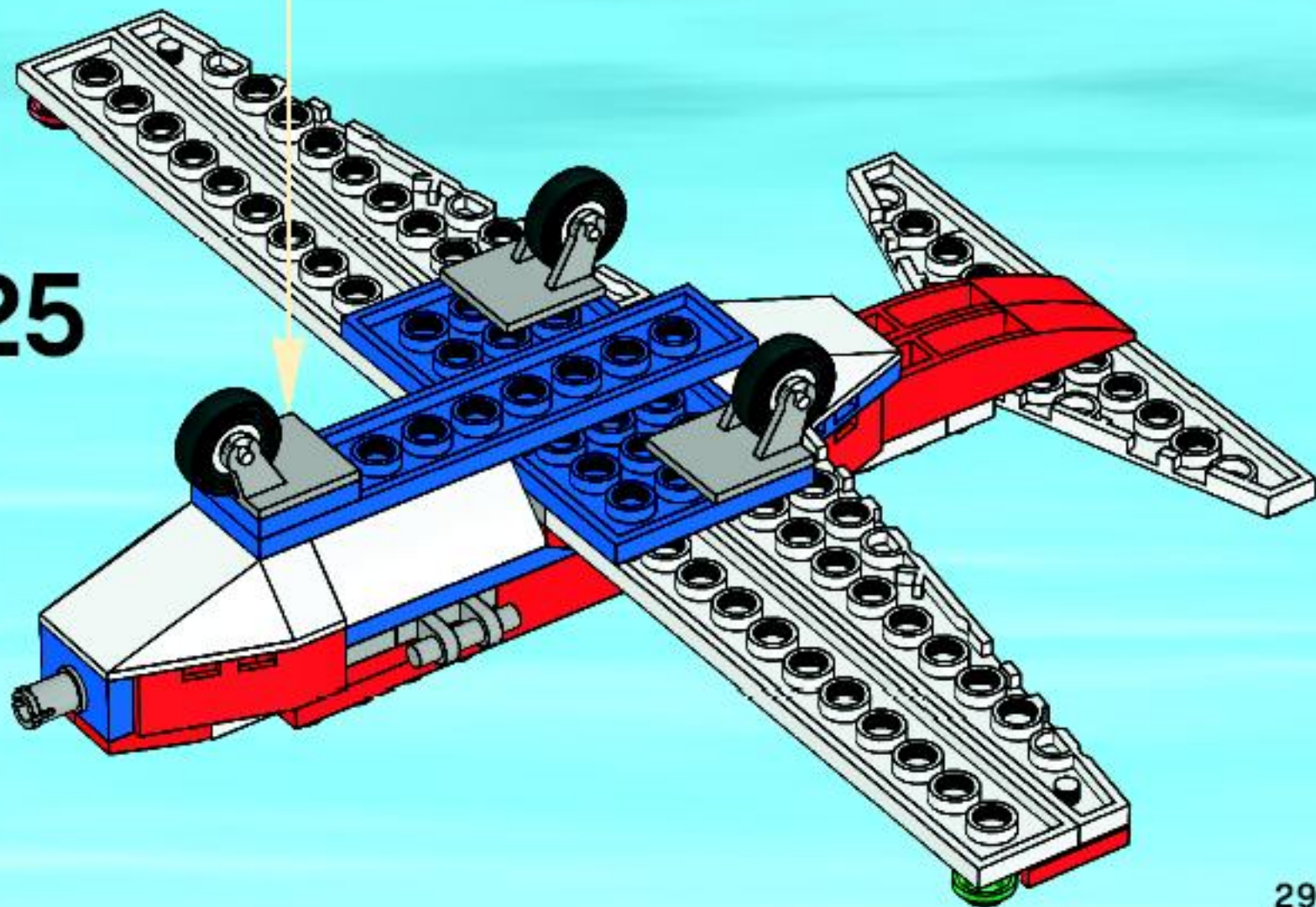

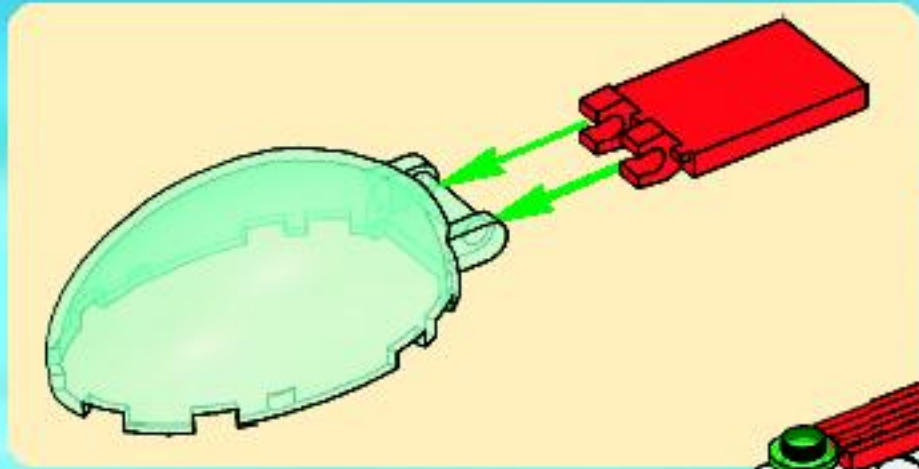

26

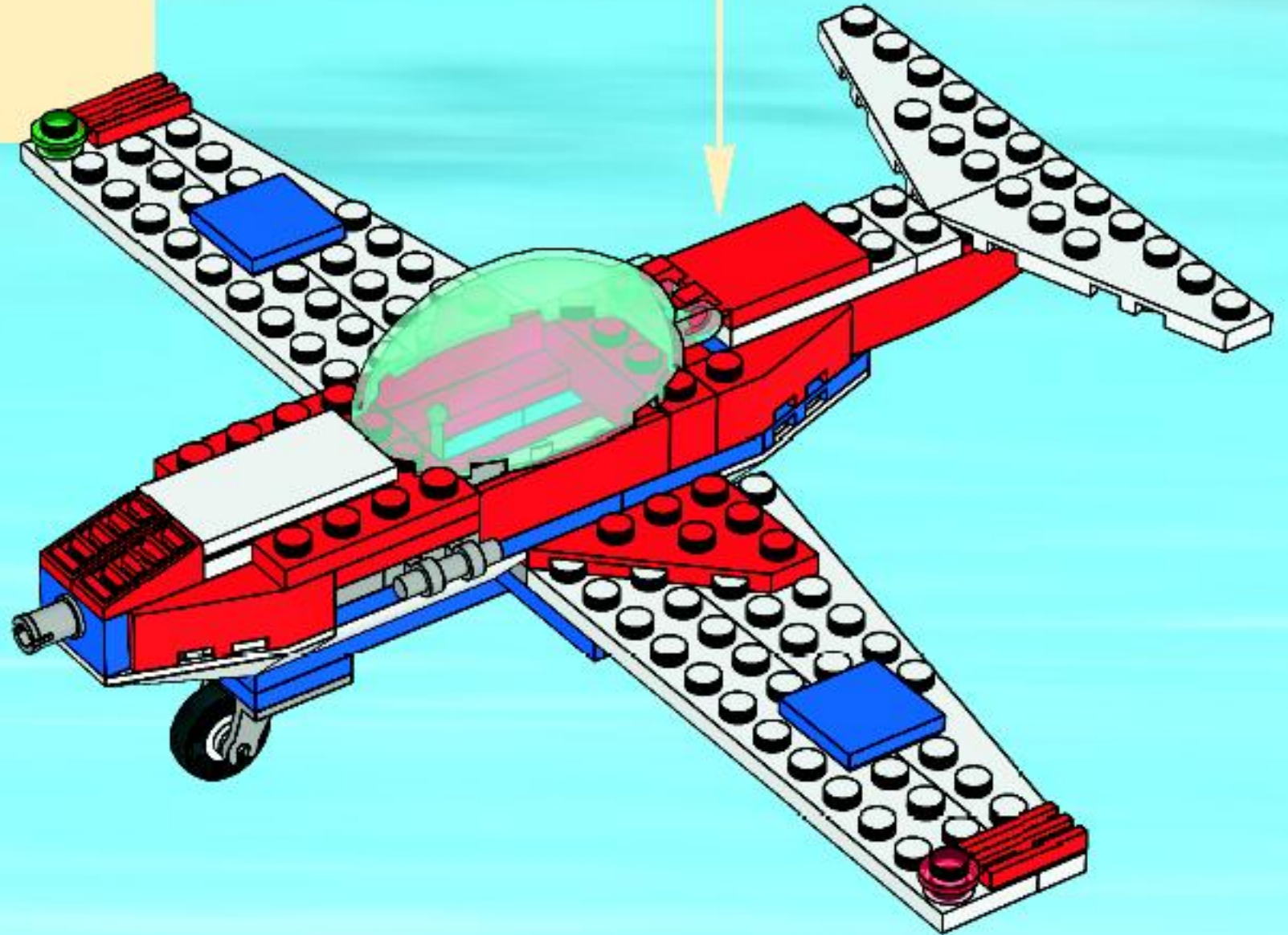



27

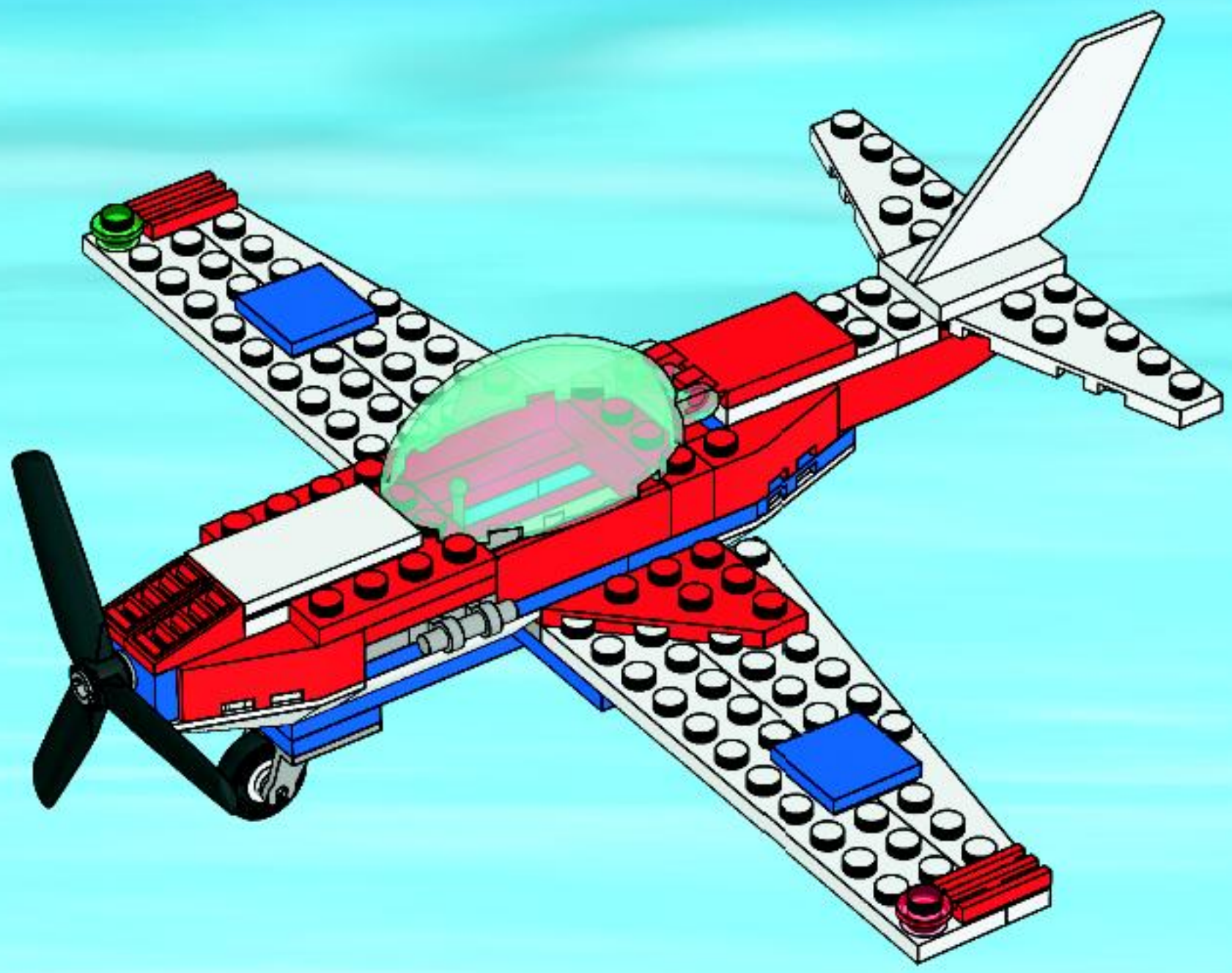



1x  
370023

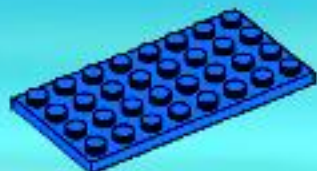

1x  
303523



1x  
300324



1x  
4211807



1x  
452226



1x  
4142731

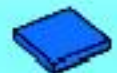

2x  
306823

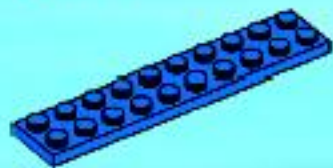

1x  
383223



1x  
408324



3x  
4211632



1x  
400626



2x  
408521



2x  
302223



2x  
4222960



1x  
4259914



3x  
4211445



4x  
4508215



3x  
241221



2x  
362323



1x  
3005741



1x  
379424



4x  
4211765



3x  
4516843



2x  
362321



1x  
4240005



1x  
3005748



1x  
306224



3x  
4211351



1x  
9339



1x  
371021

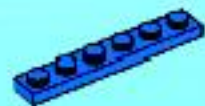

2x  
366623



1x  
4571078



1x  
4256320



2x  
4107758



1x  
302026



1x  
302221



1x  
302128



1x  
244126





1x  
4562544



2x  
4252586



3x  
4296997



1x  
4560178



1x  
4287708



1x  
4287707



2x  
4540382



1x  
74335



1x  
9551



2x  
434501



1x  
4208987



1x  
4209005



2x  
4171662



1x  
4275870



2x  
434601

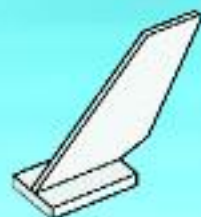

1x  
623901



4x  
302301

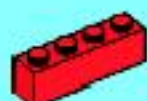

1x  
301021



1x  
4243814



1x  
4547489



1x  
4289569



1x  
4530734



2x  
4178728



1x  
302001

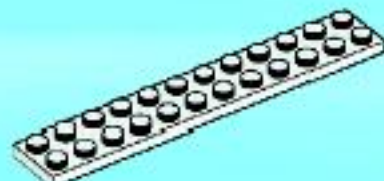

2x  
244501



2x  
4160406



2x  
4230901



2x  
485501



Customer Service

Kundenservice

Service Consommateurs

Servicio Al Consumidor

[www.lego.com/service](http://www.lego.com/service) or dial



: 00800 5346 5555

: 1-800-422-5346



**FREE! GRATIS! GRATUIT!**



**club**  
MAGAZINE™

**www.LEGOclub.com**



**00800 5346 5555\***        



**1-866-534-6258 • 1-877-518-5346**

US & Canada only

Canada seulement

\* Free phone. Mobile charges may apply. \* Numéro sans frais. Les frais peuvent s'appliquer avec les téléphones cellulaires. \* Gelokkeerd, Kosten Rij Aanvullend als Mobilfunkkosten können in rekening gebracht.  
\* Gratis telefonnummer van PostNet. \* Debet este gratis nummer, năru duringer Pro PostNet. \* Det är gratis, utifrån ringar från PostNet.



VISIT THE WORLD'S  
BIGGEST LEGO® SHOP!

**www.LEGOshop.com**









# WIN!

Go to [www.nielsen.com/LEGO](http://www.nielsen.com/LEGO) to fill out a survey for a chance to win a cool LEGO® Product.

No purchase necessary.

Open to all residents where not prohibited.



[www.LEGO.com](http://www.LEGO.com)



## [www.nielsen.com/LEGO](http://www.nielsen.com/LEGO)

### GEWINNE!

Nimm an der Umfrage auf [www.nielsen.com/LEGO](http://www.nielsen.com/LEGO) teil und hab die Chance ein cooles LEGO® Produkt zu gewinnen!

Die Teilnahme am Gewinnspiel führt zu keinerlei Kaufverpflichtungen. Teilnahme in allen nicht ausgeschlossenen Ländern möglich.

### WIN!

Ga naar [www.nielsen.com/LEGO](http://www.nielsen.com/LEGO), vul een enquêteformulier in en maak kans op een cool LEGO® product.

Geen aankoopverplichting. Iedereen mag deelnemen, uitgezonderd ingezetenden van landen waar een enquêteverbod geldt.

### GAGNE!

Visite [www.nielsen.com/LEGO](http://www.nielsen.com/LEGO) pour répondre à un questionnaire et avoir une chance de gagner un produit LEGO® très cool!

Aucune obligation d'achat. Ouvert à tous les résidents des pays autorisés.

### 当てよう!

[www.nielsen.com/LEGO](http://www.nielsen.com/LEGO) にアクセスして、アンケートにご記入ください。当選者にはレゴ製品を差し上げます。

お買い上げの必要はありません。禁止されていない限り、すべての店舗にご利用いただけます。