



Disney · PIXAR  
**Toy**  
STORY



7591



1

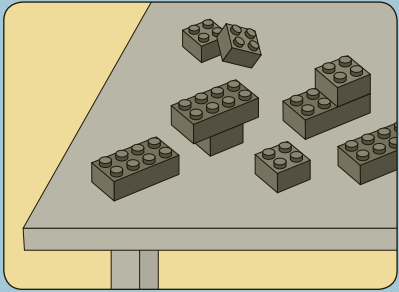
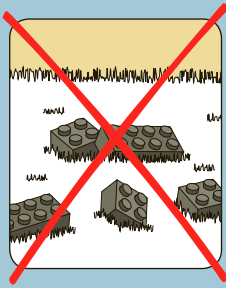

2

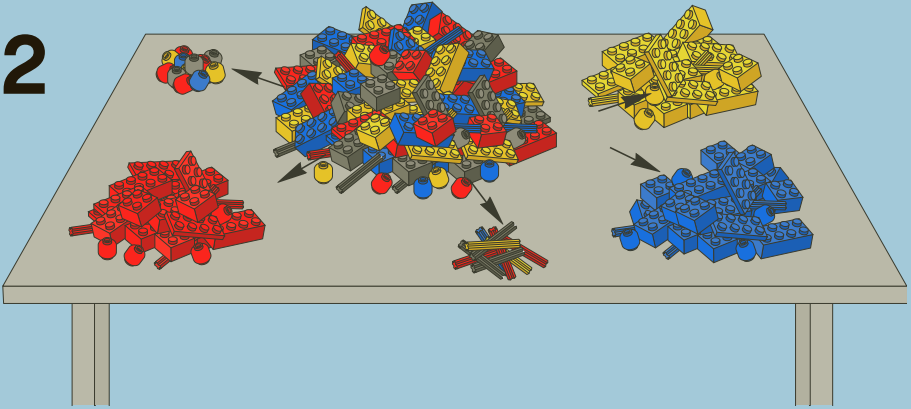

3

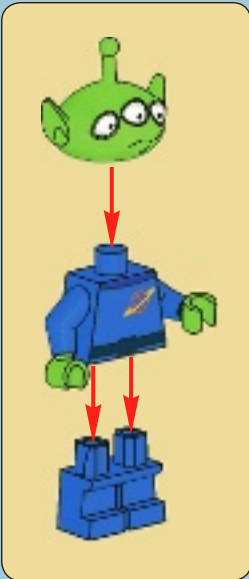

2

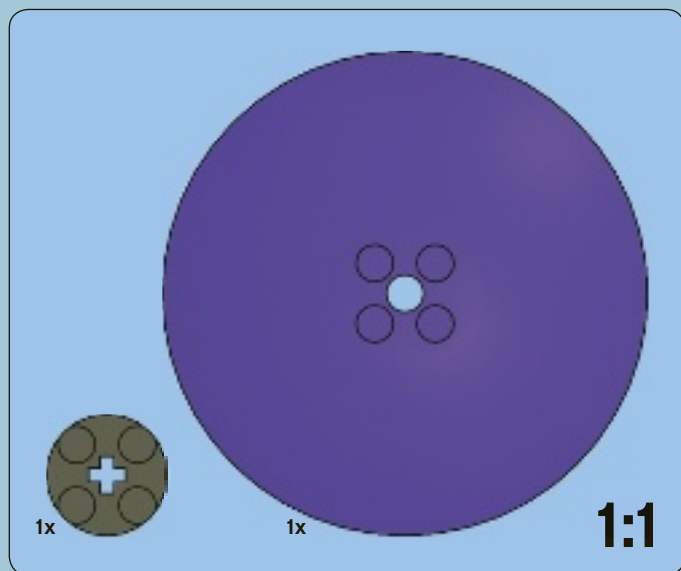

**1**

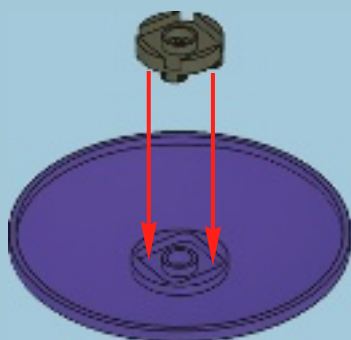

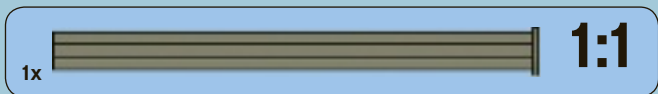

2

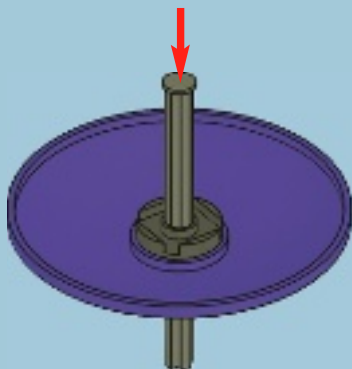

3

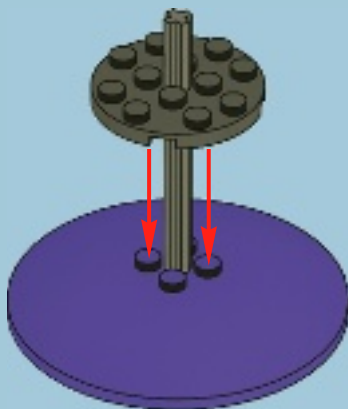

4

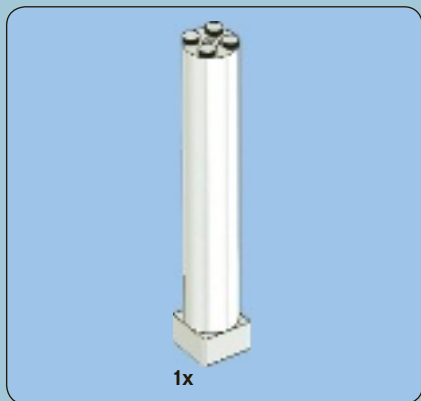

4

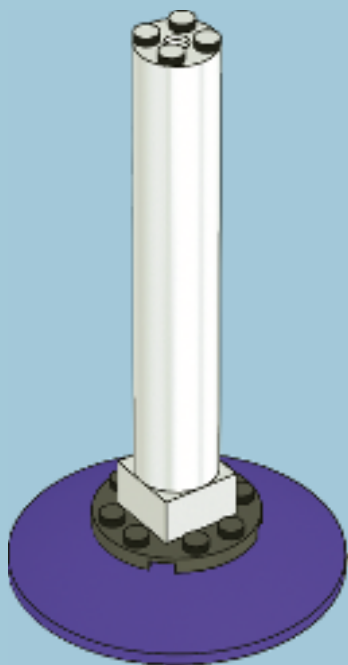



1x

5

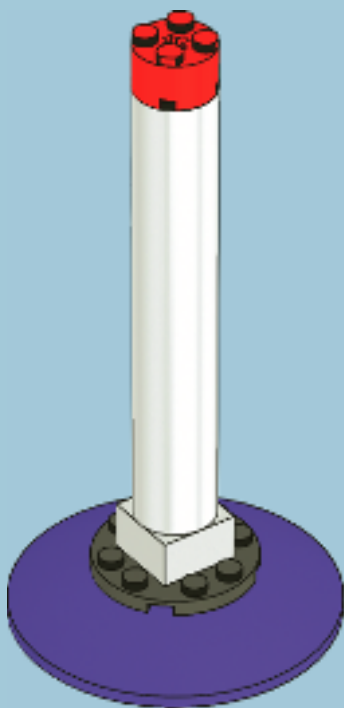



6

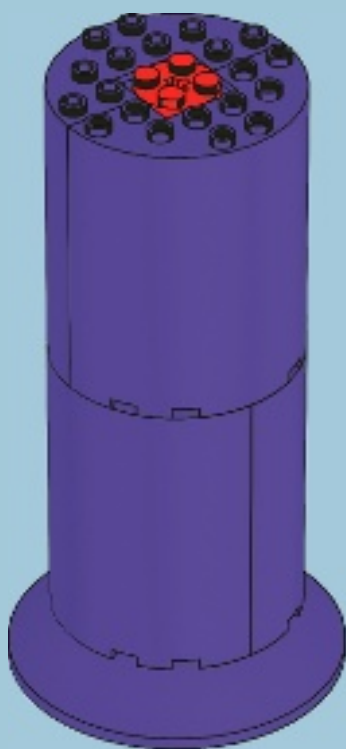



1x

7

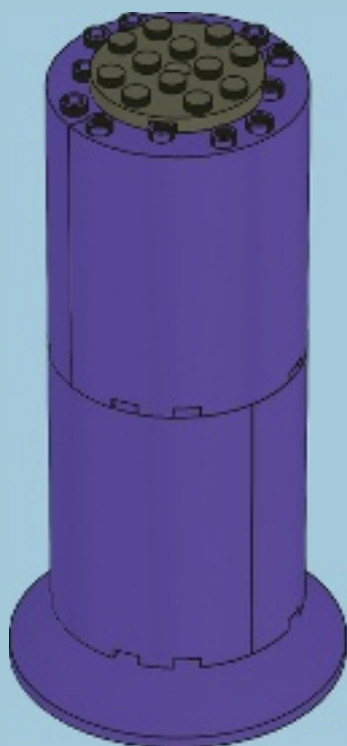

8



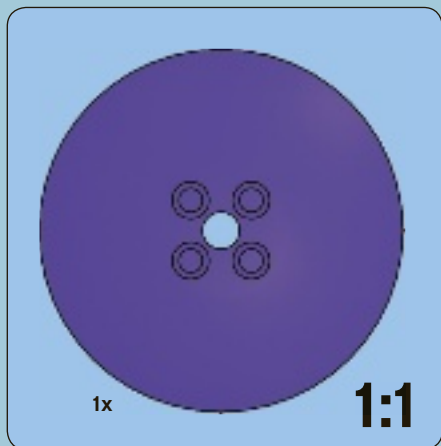

8

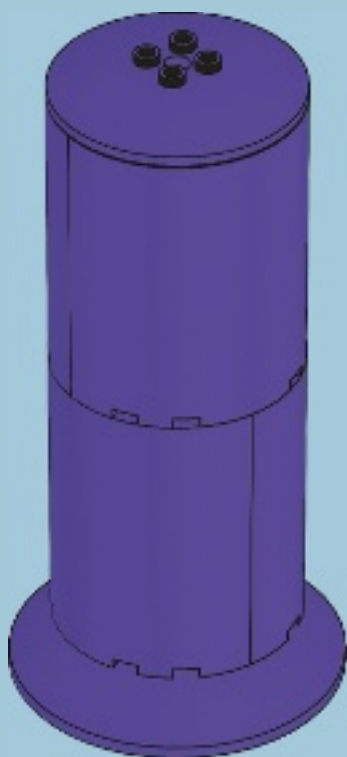

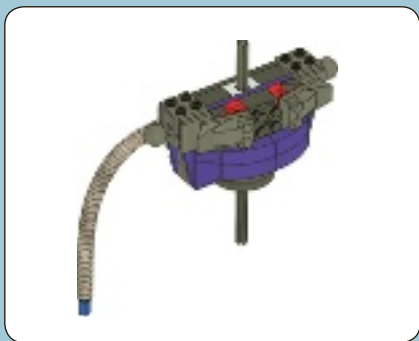

1x



1x

# 1

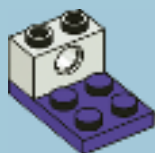

1x



1:1

# 2

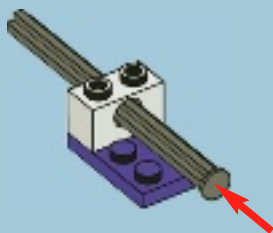

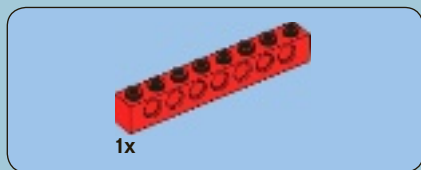

3

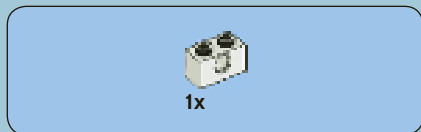
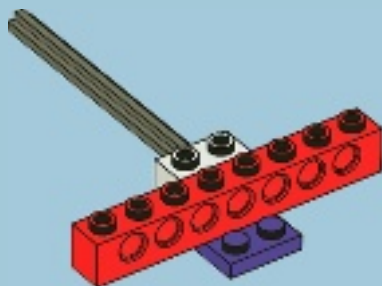

4

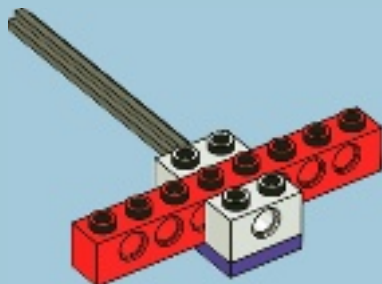



5

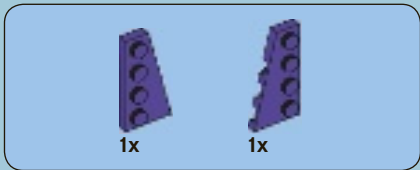
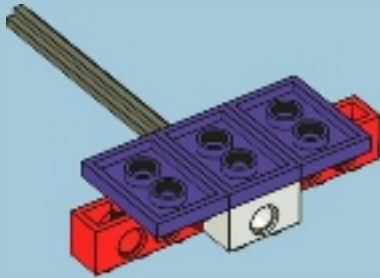

6

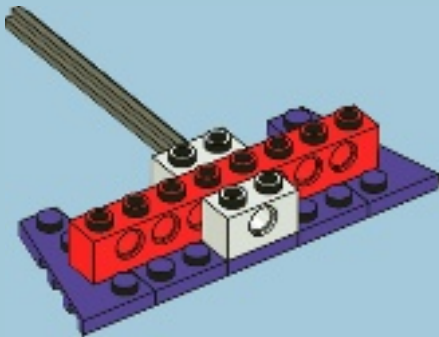



2x



2x

# 7

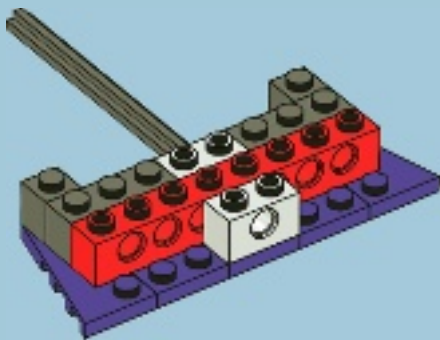

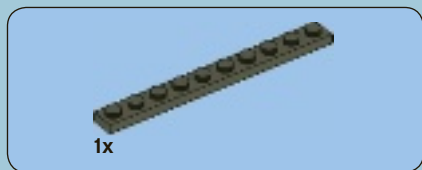

8

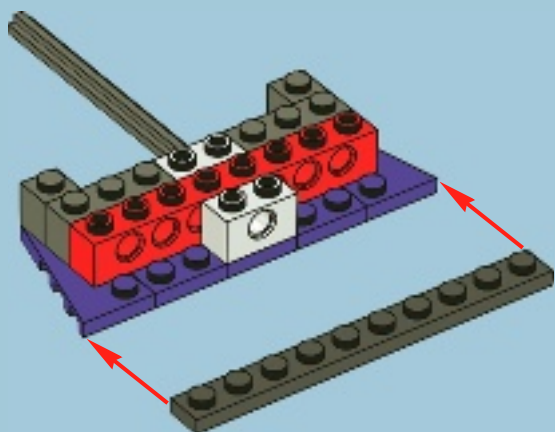



2x

# 9

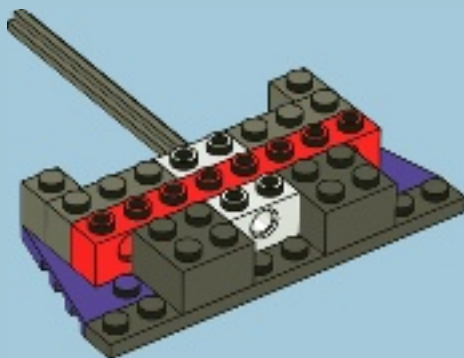

2x

# 10

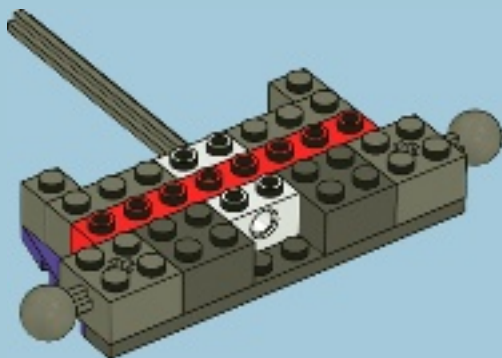



1x



1x



1:1

# 11

1

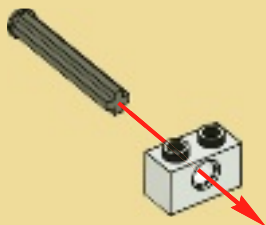

2

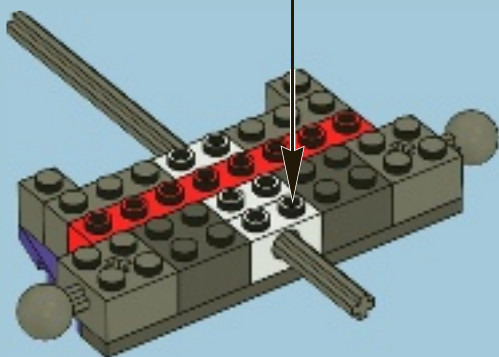
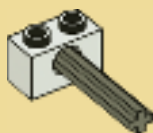





12

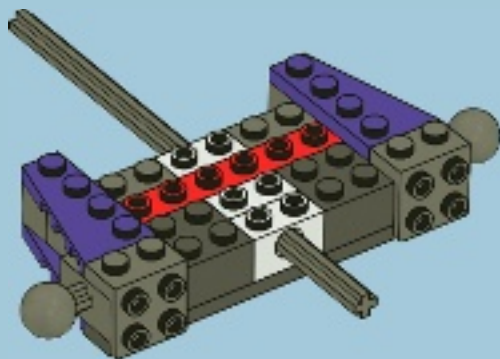



4x

# 13

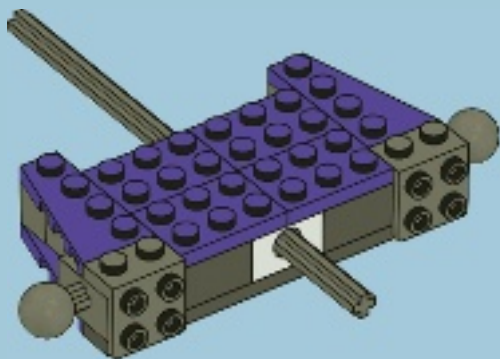

1x



1x

# 14

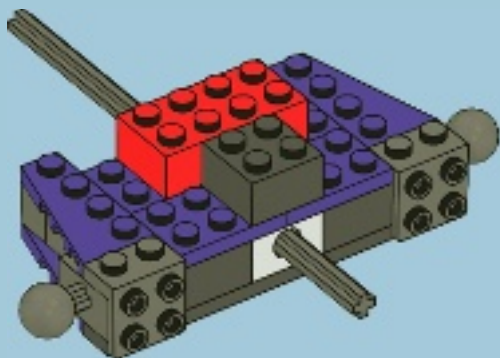



2x



2x

# 15

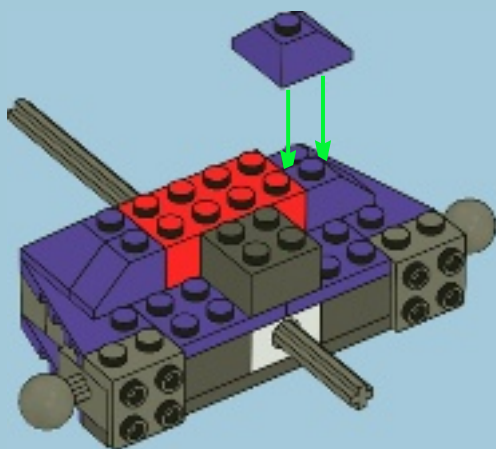



2x

# 16

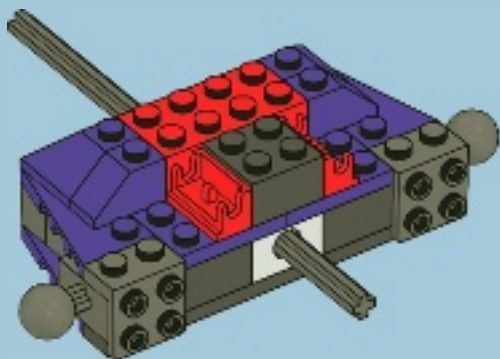

2x



2x

# 17

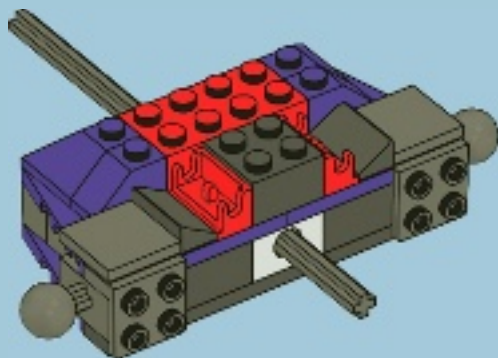



2x



2x

# 18

1

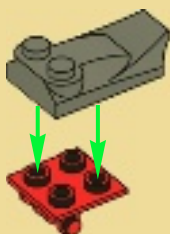

2



2x

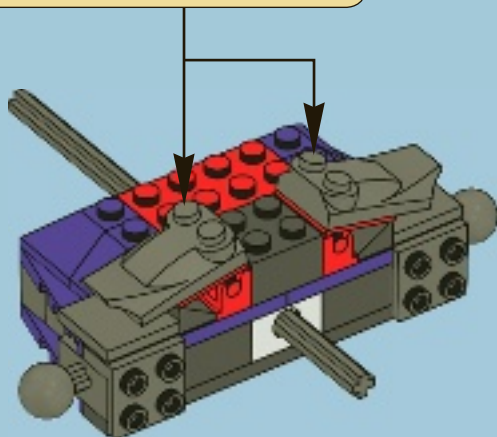



2x

# 19

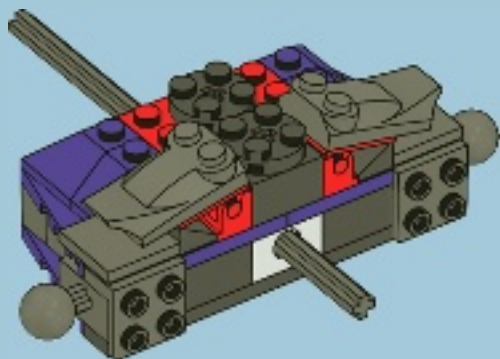



4x

# 20

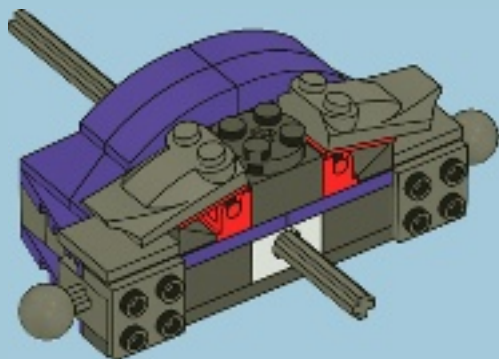



1x



# 21

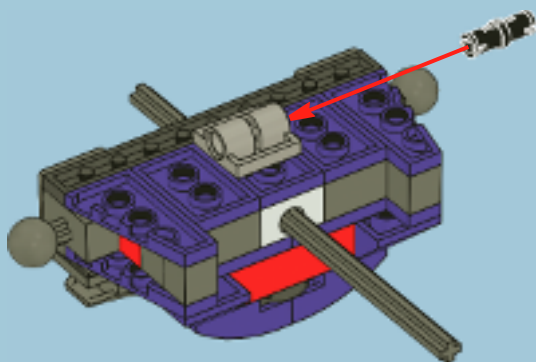
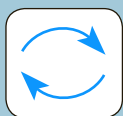





# 22

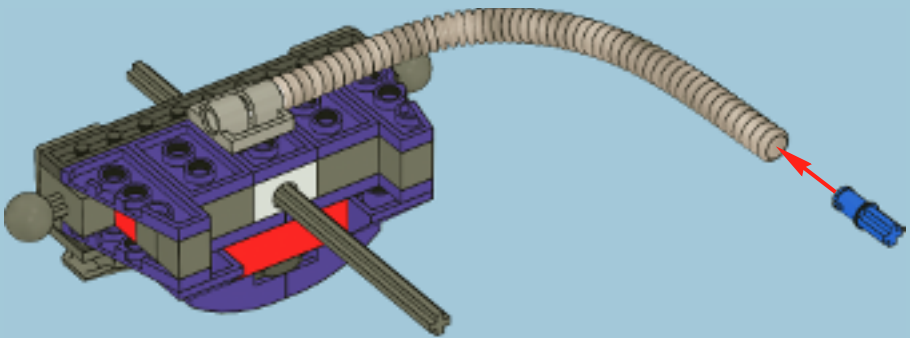

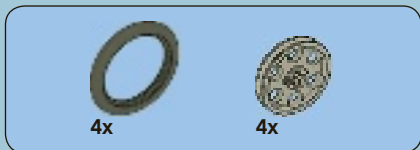

# 23

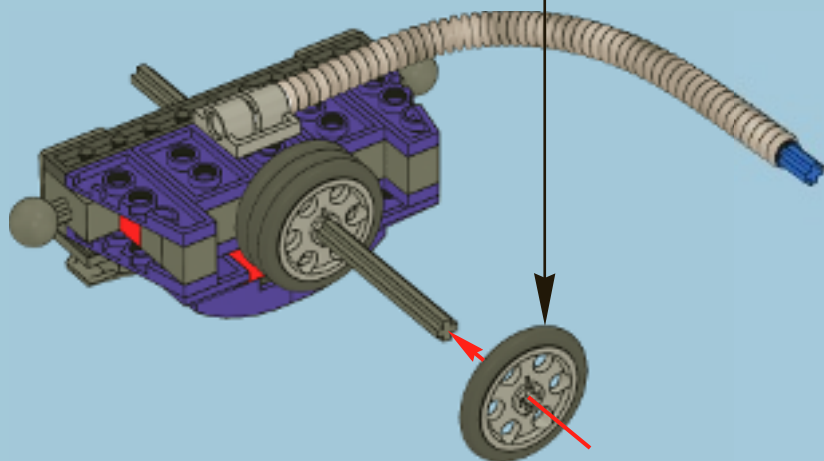
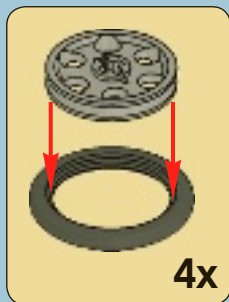

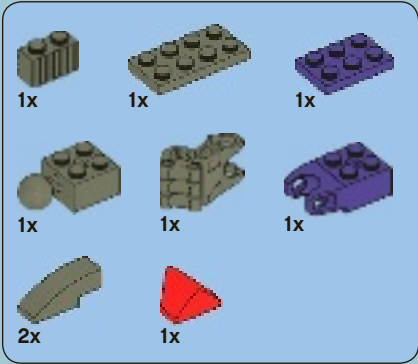

# 24

1

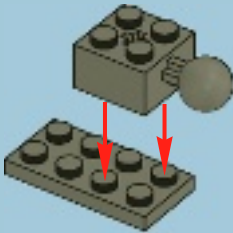

2

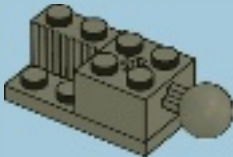

3

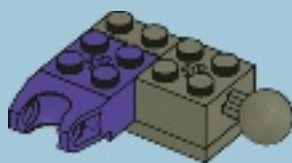

4

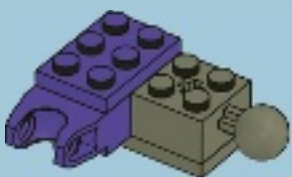

5

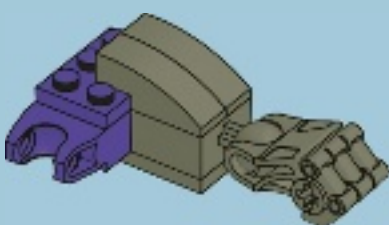

6

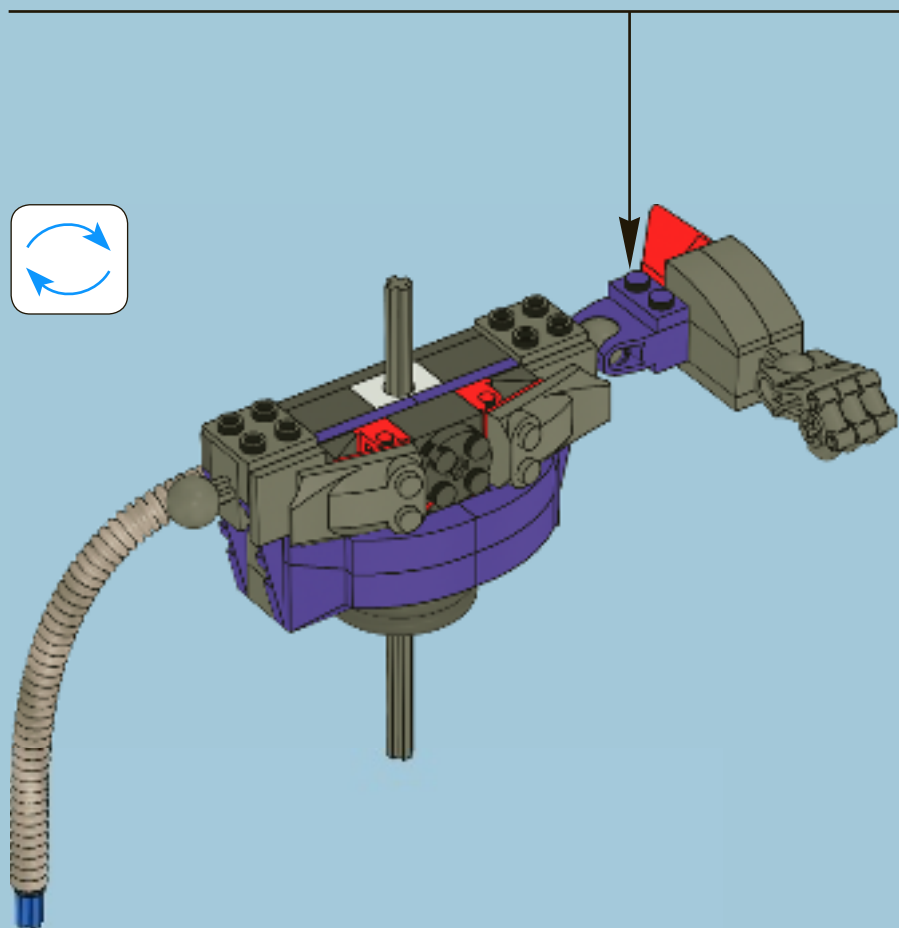
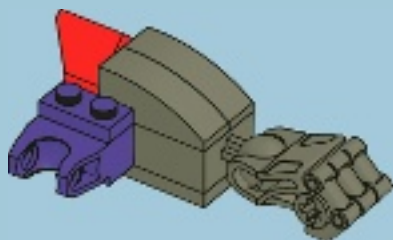

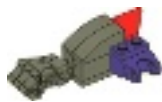

1x



1x



1x



1x



1x



1x



2x



1x

# 25

## 1

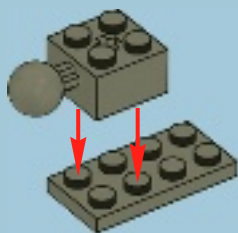

## 2

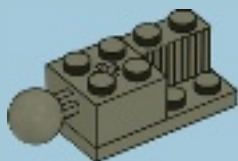

**3**

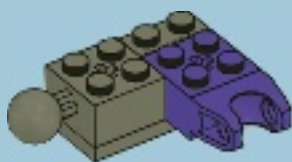

**4**

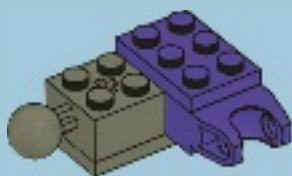

**5**

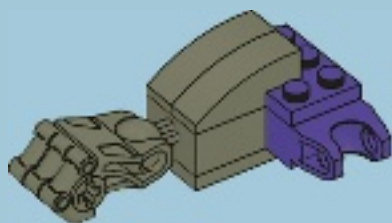

6

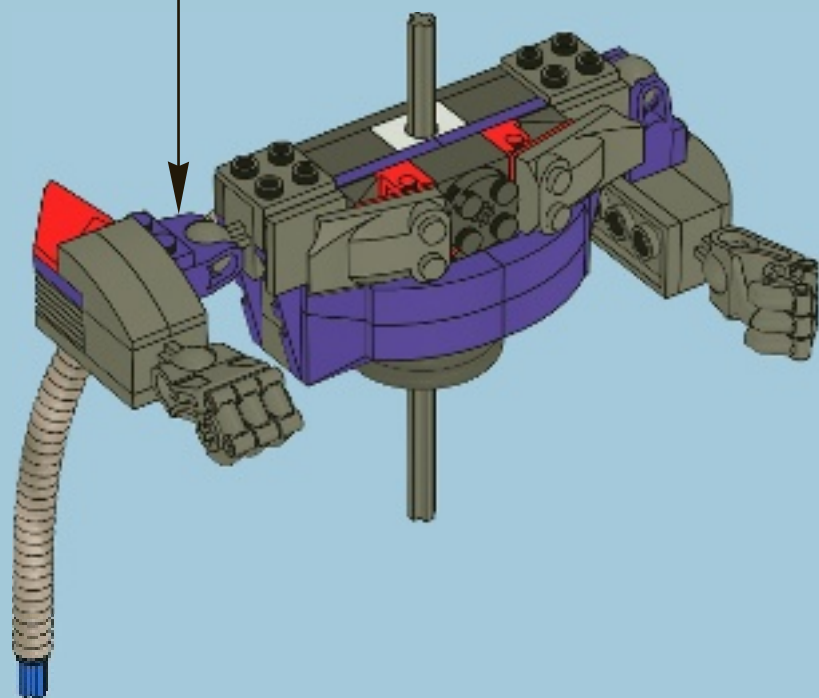
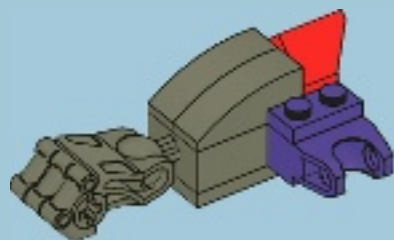





1x



2x

# 26

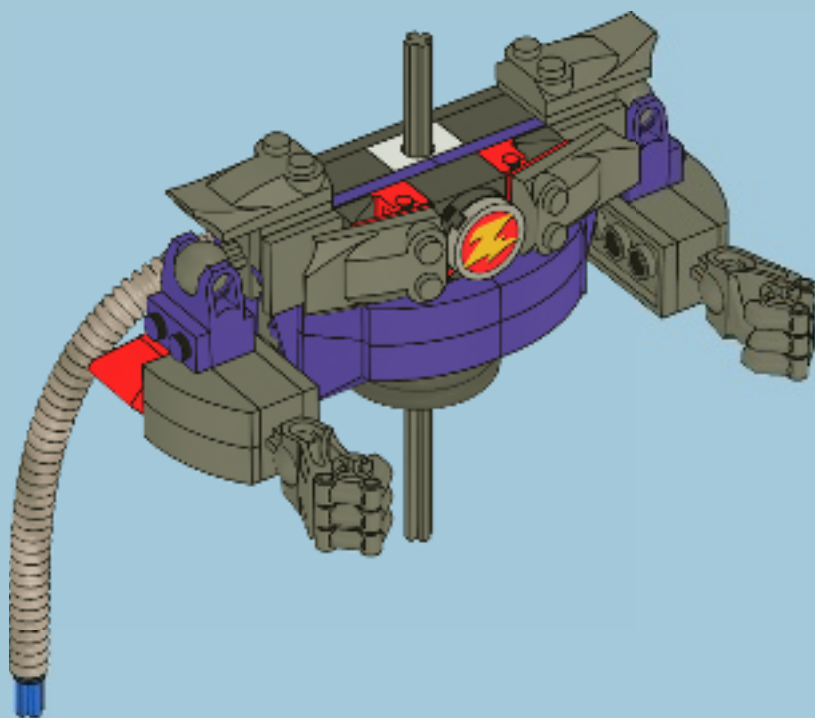

27

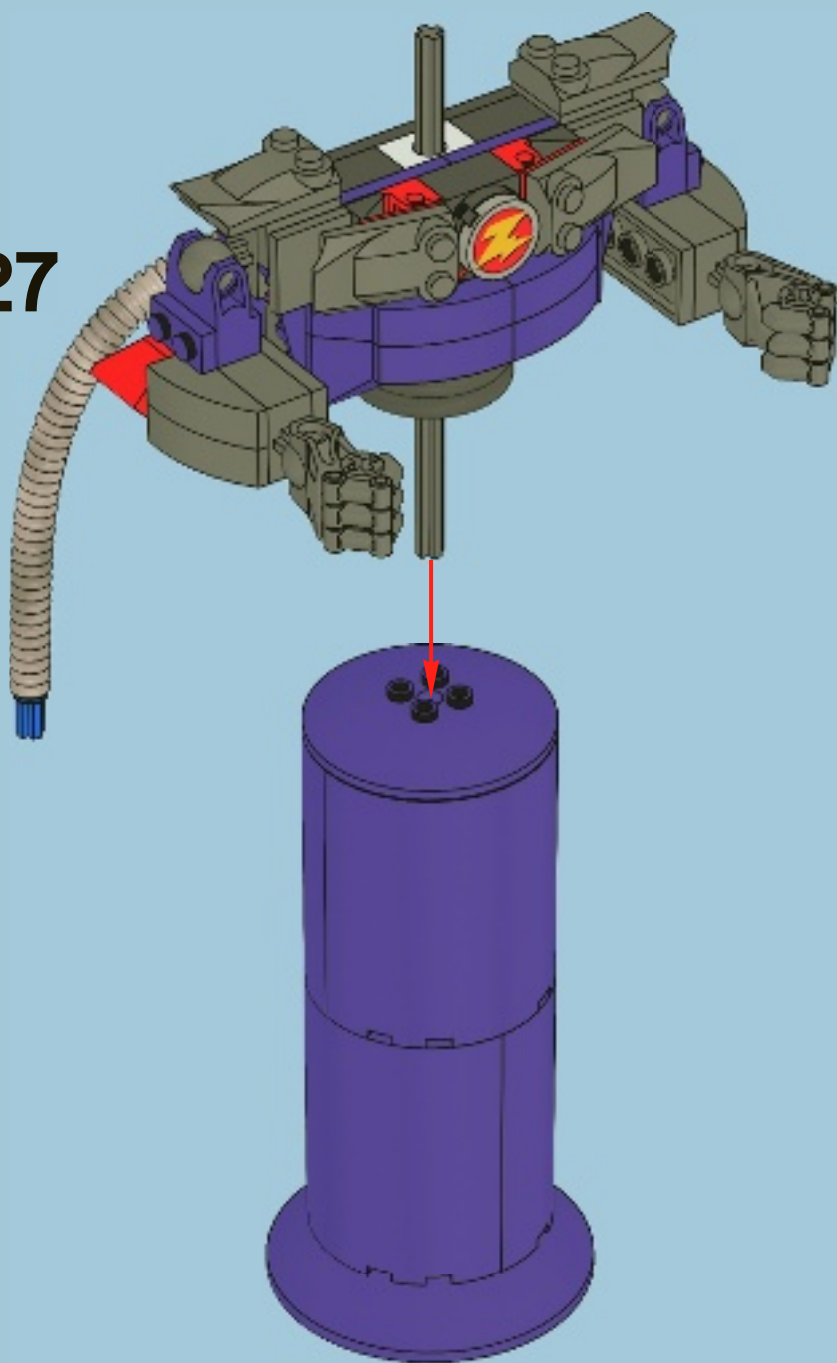

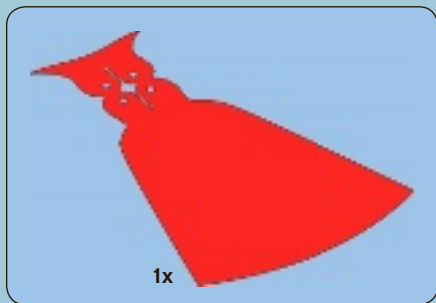

28

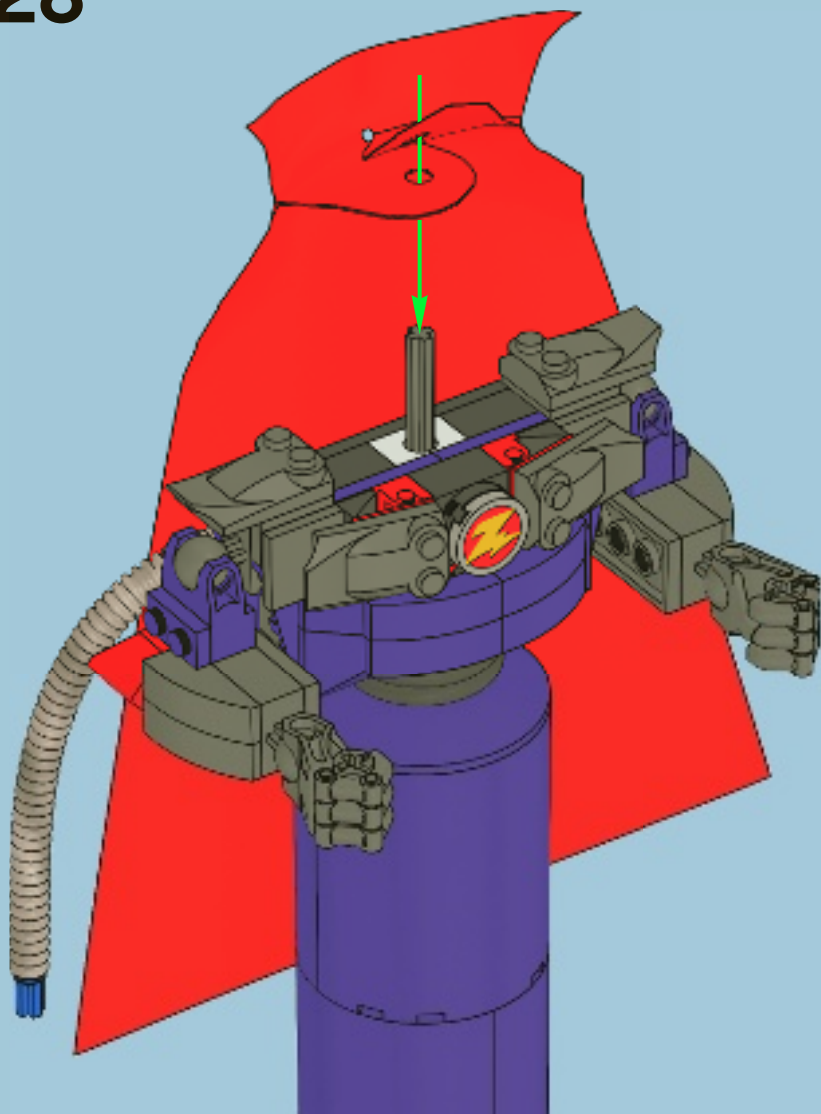



# 29

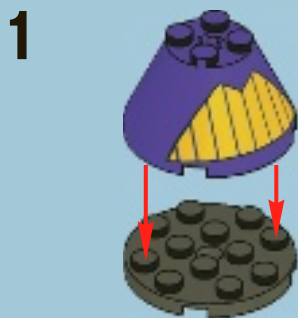

3



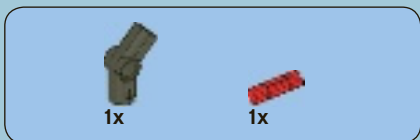

1

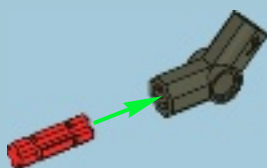

2

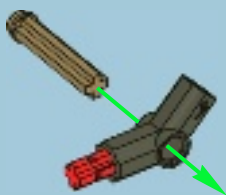



1x

3



1x



1x

4

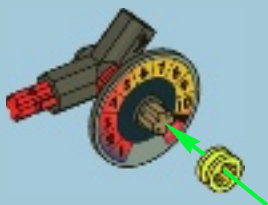



5

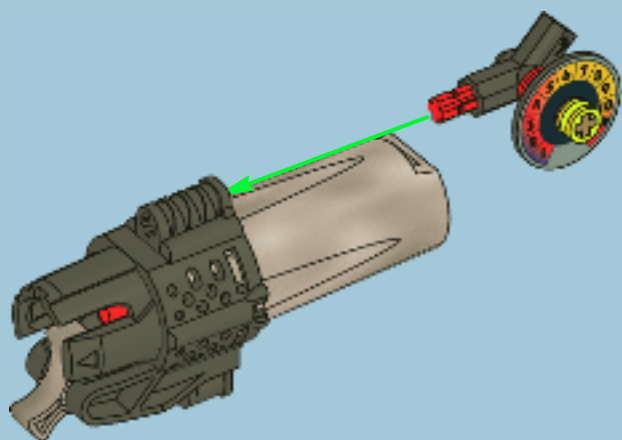





1x

6

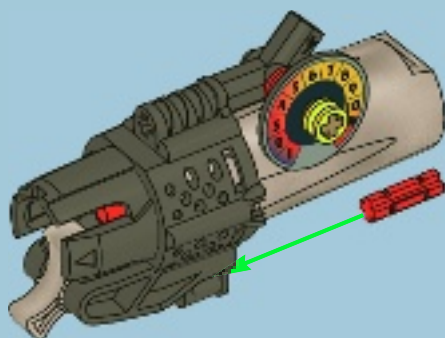

1x

7

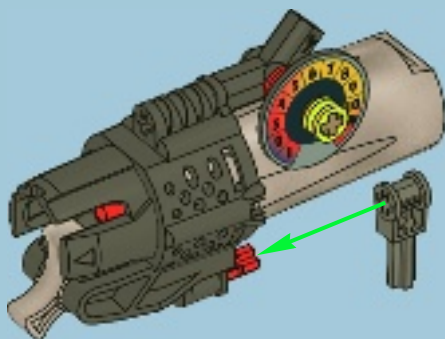

30



31





3x

32





Disney · PIXAR  
**TOY**  
STORY





Disney · PIXAR  
**TOY**  
STORY

**7591**



**7592**





Disney · PIXAR  
**TOY**  
STORY



**7590**



**7595**





Disney · PIXAR  
**TOY  
STORY**

**7593**



LEGO and the LEGO logo are trademarks of the LEGO group.  
©2010 The LEGO group.  
© Disney/Pixar.





Disney · PIXAR  
**TOY**  
STORY

**7594**



3x  
370001



1x  
4100331



1x  
370221



1x  
300121



1x  
614321



2x  
4258056



2x  
393721



2x  
613421



1x  
4227155



2x  
4142865

1x  
4563687



1x  
4565969



1x  
4543857



1x  
4206482



3x  
4545434



1x  
4239601



1x  
4121715



1x  
447726



3x  
4515350



3x  
403226



1x  
4121610



3x  
300326



2x  
4548180

2x  
3005741



1x  
4521177



1x  
4495191



1x  
4566927



1x  
4211376



1x  
4566260



4x  
4494222



2x  
4211098



2x  
4211104



2x  
4210636



4x  
4497253



4x  
4246896

1x  
4589910



1x  
4566525



1x  
4569082



2x  
4211055



2x  
4211065



2x  
4277928



4x  
4570879



2x  
4541458



1x  
4210665



1x  
4560177



2x  
4499858



4x  
281526



1x  
4578066

4x  
4566270



1x  
4565968

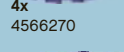

2x  
4566613

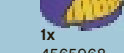

2x  
4566522



2x  
4225170

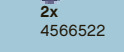

2x  
4225145



2x  
4225145



2x  
4225265



2x  
4224871



4x  
4578772

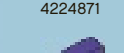

9x  
4225142

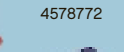

1x  
4562067



### Customer Service

Kundenservice

Service Consommateurs

Servicio Al Consumidor

[www.lego.com/service](http://www.lego.com/service) or dial



00800 5346 5555 :



1-800-422-5346 :



FREE! GRATIS! GRATUIT!

LEGO

club  
MAGAZINE

www.LEGOclub.com



00800 5346 5555\*



1-866-534-6258 • 1-877-518-5346

US & Canada only

Canada seulement

\* Freephone. Mobile charges may apply. \* Numéro sans Frais. Des Frais peuvent s'appliquer avec les téléphones cellulaires.  
\* Gebührenfrei, Kosten für Anrufe aus Mobilfunknetzen können abweichen. \* Gratis telefonnummer vanaf vaste lijn.  
\* Det er ett gratis nummer, når du ringer Pro Posttelefon. \* Det är gratis, när du ringer Från en Post telefon.



VISIT THE WORLD'S  
BIGGEST LEGO® SHOP!

www.LEGOshop.com



# WIN!

Go to [www.nielsen.com/LEGO](http://www.nielsen.com/LEGO)  
to fill out a survey for a chance  
to win a cool LEGO® Product.

No purchase necessary.

Open to all residents where not prohibited.

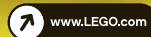

## [www.nielsen.com/LEGO](http://www.nielsen.com/LEGO)

### GEWINNE!

Nimm an der Umfrage auf  
[www.nielsen.com/](http://www.nielsen.com/)  
LEGO teil und hab die Chance ein cooles  
LEGO® Produkt zu gewinnen!

Die Teilnahme am Gewinnspiel führt zu keinerlei  
Kaufverpflichtungen. Teilnahme in allen nicht  
ausgeschlossenen Ländern möglich.

### WIN!

Ga naar [www.nielsen.com/LEGO](http://www.nielsen.com/LEGO),  
vul een enquêteformulier in en  
maak kans op een  
cool LEGO® product.

Geen aankoopverplichting.  
Iedereen mag deelnemen, uitgezonderd  
ingezetenden  
van landen waar een enquêteverbod geldt.

### GAGNE !

Visite [www.nielsen.com/LEGO](http://www.nielsen.com/LEGO)  
pour répondre à un questionnaire  
et avoir une chance de gagner  
un produit LEGO® très cool !

Aucune obligation d'achat.  
Ouvert à tous les résidents des pays  
autorisés.

### 当てよう!

[www.nielsen.com/LEGO](http://www.nielsen.com/LEGO)  
にアクセスして、  
アンケートにご記入ください。  
当選者にはレゴ製品を  
差し上げます。

お買い上げの必要はありません。  
禁止されていない限り、すべての皆様にご利用いただけます。