



# THE LEGO MOVIE



70840

1	5	9	13	
2	6	10	14	
3	7	11	15	17
4	8	12	16	18



## MIKE MITCHELL

Director

*Apocalypseburg is a tough, gritty, heckish place to live. It is designed to contrast with the bright and fun Bricksburg from THE LEGO® MOVIE™. Our dusty Apocalypseburg shows how our characters have struggled for years after the DUPLO® invasion. It also demonstrates how Finn, the older brother who is behind the story in the first movie, is growing up and shifting his sense of play.*



## TRISHA GUM

Co-Director

*We wanted the Statue of Liberty to be the central point of the citadel. So many disaster movies use a ruined version of this iconic statue to highlight the gravitas of destruction the world has faced... we wanted to play up that trope and parody it in our movie.*



## MATTHEW ASHTON

Executive Producer/Vice President of Design at the LEGO Group

*The haphazard architecture of Apocalypseburg was designed to suggest that the characters have repurposed the remnants and rubble of their destroyed town, Bricksburg. The dusty earth tones and muted shades were used to contrast the only positive force left in the citadel, Emmet, a shining, bright-orange beacon of hope, who continues to believe 'Everything is AWESOME!' despite the 'heck-hole' he has found himself living in.*



### How does THE LEGO® MOVIE 2™ link back to THE LEGO MOVIE™?

THE LEGO® MOVIE 2™ kicks off exactly where the first movie ends, with the 'DUPLO® Invasion' when the little sister comes down to the basement to play with her brother Finn, with their dad's giant LEGO display. The movie then skips forward a few years and we find ourselves in the aftermath of the DUPLO attack, in the makeshift citadel of 'Apocalypseburg', which has been crudely constructed from the debris of Bricksburg. After years of battling to defend their new realm, all our favorite heroes have become gritty, hardened and more edgy, ...except of course for Emmet, who refuses to have anything but a positive outlook on life. That is until a mysterious spacecraft appears, piloted by the formidable General Mayhem! She abducts all his friends to the far-off galaxy known as the 'Systar System', leaving Emmet no choice but to try and rescue the gang! 'But can Emmet toughen up and be the 'man' he thinks Lucy wants him to be?' That's the question that only 'THE LEGO MOVIE 2' can answer!

### How well do you think the model captures the spirit of THE LEGO MOVIE 2?

It captures the feeling of the first act perfectly. We made the ruined Statue of Liberty the focal point of the model, selected the most iconic scenes from the introduction to Apocalypseburg, and incorporated them around the structure. Justin Ramsden (Senior Model Designer) has done an amazing job expanding on what you actually see in the movie, by creating individual dwellings for each of the characters, while adding fun details and accessories that tie in with their personalities.

### What is your favorite feature or function in the model?

I love the dramatic silhouette of the model in its entirety. It's a real showstopper and will be absolutely great to display. The interpretation of the statue is spot-on, and I think fans will really appreciate the clever 'modularity' designed into the build and how each compartment can be removed so you can get right in there to see the incredible details. I am also really pleased we have been able to include a selection of DC Comics characters in this set, a fully kitted out post-apocalyptic version of LEGO Batman™, Green Lantern™ and Harley Quinn™.



# Welcome to Apocalypseburg!

When we left Emmet and his best brick buddies at the end of THE LEGO® MOVIE™, he was the sweetest, most optimistic guy you could meet. In THE LEGO MOVIE 2™, however, Emmet's eternal optimism and master-building skills have been put to the ultimate test – Bricksburg is in ruins, and everyone is just trying to survive in the ensuing chaos. The future of play itself is at stake.

Apocalypseburg is Emmet's new, haphazard-looking hometown. Refabricated from parts of the now defunct Bricksburg, the model comprises 3,178 bricks and 12 minifigure characters. It has all the post-apocalyptic mayhem, action and humor to let you recreate some of your favorite movie scenes, plus a few extra locations. And, of course, it wouldn't be complete without imaginative building techniques that push your LEGO bricks to new limits. Discover hidden references and funny surprises, functions and details as you build and play, and you can even expand the set with your own creative ideas and designs. The fate of Apocalypseburg is in your hands!

Meet the team behind the model. How did the harmonious Bricksburg turn into the dystopian wasteland that is Apocalypseburg? How have Lucy, Batman™ and all your other favorite characters adapted to the drastic decline in living standards? And where can they even get coffee nowadays? Find out in the interviews with the movie directors and the LEGO designers.



# A place near the Coffee Shop

**What were the most challenging and the most important features?**  
 It was important to keep the dramatic proportions and angles, which meant that getting the scale right was key. Finding that balance was a fun challenge. I wanted it to be believable that the characters belonged there but still keep the feeling of a massive statue looming overhead. The most challenging part was creating the leaning angles and the “spiky-everywhere” look and feel, all while making sure it could be built in a sturdy way. It took a bit of math, testing, and discussions to figure out how to support the statue’s torch and head at an angle without any vertical support. Pythagorean triples saved the day again! It is always fun to push the limits of the LEGO System. Thankfully Justin figured out how to make the angles buildable and how to make it into a proper LEGO set. He absolutely nailed it.

**What are your favorite details in the model?**  
 Ooh... The secret home for the sewer babies is just hilarious. And the various Easter eggs we’ve included. You can look for little hints to the running gag that maybe Batman™ still hasn’t gotten over his relationship with Lucy. We tried to include a lot of living spaces for the minifigures in the set, like a place for Lucy to brood at the top. The idea of a coffee shop in this environment is so funny to me, because really, what IS a coffee shop in a post-apocalyptic setting, anyway?

**How many sketch versions of this model did you do before reaching the final version?**  
 As a team, we sketched and dreamed up several different versions and it evolved quite a bit from start to finish. Some versions did not include the Statue of Liberty but represented other parts of Apocalypseburg, and some were used as artwork to help create the movie scenes. It is fun to look back and compare the final concept model with the finished set.

## JOEL DAVID BAKER Concept Designer at the LEGO Group Q&A with Joel

**What was the most fun part of designing this new model?**  
 The attitude and style of the post-apocalyptic wasteland was incredibly fun to build. It was interesting to try to capture the “roughly cobbled together” look and feel of it, while at the same time making it a sturdy LEGO® model. My favorite part to design was Lady Liberty’s head with the details of her crown and her stoic expression.

**What does a Concept Designer do at the LEGO Group that is different from other Designers?**  
 We focus on generating new ideas and communicating those ideas. Sometimes the idea is put into a drawing or digital build; sometimes it’s a quick doodle with a few words on a sticky note! It can be new themes, a new set, or even new elements. We’ll discuss the various ideas, pick which ones to build as concept models, and then choose our favorite to refine into a LEGO set. It is a very collaborative effort. This type of design means building from scratch with a lot of passion, a bit of research, and tons of inspiration.

**What sources of inspiration did you have?**  
 A lot of the inspiration came from working with Patrick Hanenberger (Production Designer) and the Concept Artists and Animators, our wonderful Directors Mike Mitchell and Trisha Gum, and our brilliant writers and Producers Phil Lord and Chris Miller. They were all very open to adding as many ideas, jokes, and references as we could cram in.



**From left to right/top-down** Joseph Richard Coleman - Senior Designer | Karina Schanz - Senior Master Data Specialist | Stine Mosgaard - Associate Marketing Manager | Joel David Baker - Concept Designer | Martin Højen Holm Buk - Building Instruction Specialist | Michael Patton - Graphic Designer | Justin Ramsden - Senior Model Designer | Pat M. Madsen - Project Director | Henk van der Does - Senior Model Coach | Paul Constantin Turcano - Senior Graphic Designer | Maria Bloksgaard Markussen - Marketing Manager | Mette Vraa - Marketing Director | Mauricio Bedolla - Senior Design Manager

# JUSTIN RAMSDEN

Senior Model Designer  
at the LEGO Group  
Q&A with Justin



## What was the most fun part about designing this new model?

We had so many awesome assets to work with from the movie studio (such as concept art, digital builds of Apocalypseburg and movie animatics), while also having the creative freedom to expand on the storytelling from the movie. However, personally, the most fun that I had designing the model came from the buildings around the Statue. These small architectures went through lots of different stages and testing to find out what worked and what didn't. I took existing elements and tried to think how they would be used in this post-apocalyptic world. For instance, an old truck formed a hot tub, a train carriage became a gym (for 'training'...) and a shipping container has been turned into a barber salon – all locations that we don't see in the film but that I feel could exist in this world.

## How did you go about refining Joel's concept model?

Joel's concept model was a great starting point. I took his initial sketch, poured out a huge tub of LEGO® elements, got on my hands and knees and started building. The main goal was to see how much further I could enhance the concept model and create a full 360-degree play experience that also captured the icons from its on-screen counterpart. We all wanted people to just fall in love with Apocalypseburg and I also wanted to include as many details as possible to add even more depth to the characters and the scenes that fans could play out. I worked with both physical models and digital building and I ended up creating about thirty different sketch versions, making iteration after iteration until I got to the final product. Constructing the face of the Statue of Liberty was particularly tricky, especially when you are using predominately square-

ish parts to create organic curves. Often when you're in the middle of doing something else, for example cooking at home, you suddenly think of a solution. "How can the eyebrows be built?" Perhaps that's why I gravitated to using the hot dog elements.

## Are there any new elements in the set fans should look for?

We've created some amazing elements for THE LEGO MOVIE 2™, including new armor parts and a wig. Batman™ has really taken advantage of this new Apocalypseburg lifestyle and has a cool new armor made of old tires. Other than that, LEGO fans will probably enjoy all the sand and olive green bricks in the set. We also managed to bring back the barbed wire element for this set, which I know a few fans will welcome back! Which is your favorite functionality in the model? My favorite play feature in the model is a chair-kicking function - it's a reference to a scene in THE LEGO MOVIE™ where Bad Cop loses his temper and kicks a chair across the room. It also doubles-up as a de-stressor tool to release any frustration...

## If you lived in Apocalypseburg, where would your home be? What would it look like?

You'd find me scavenging the wastelands of Apocalypseburg using found LEGO parts from destroyed buildings and vehicles to create new and interesting creations...!



# MICHAEL PATTON AND PAUL CONSTANTIN TURCANO

Michael Patton /Graphic Designer at the LEGO Group

Paul Constantin Turcano /Senior Graphic Designer at the LEGO Group

Q&A with Mike & Paul

# Capturing all the details

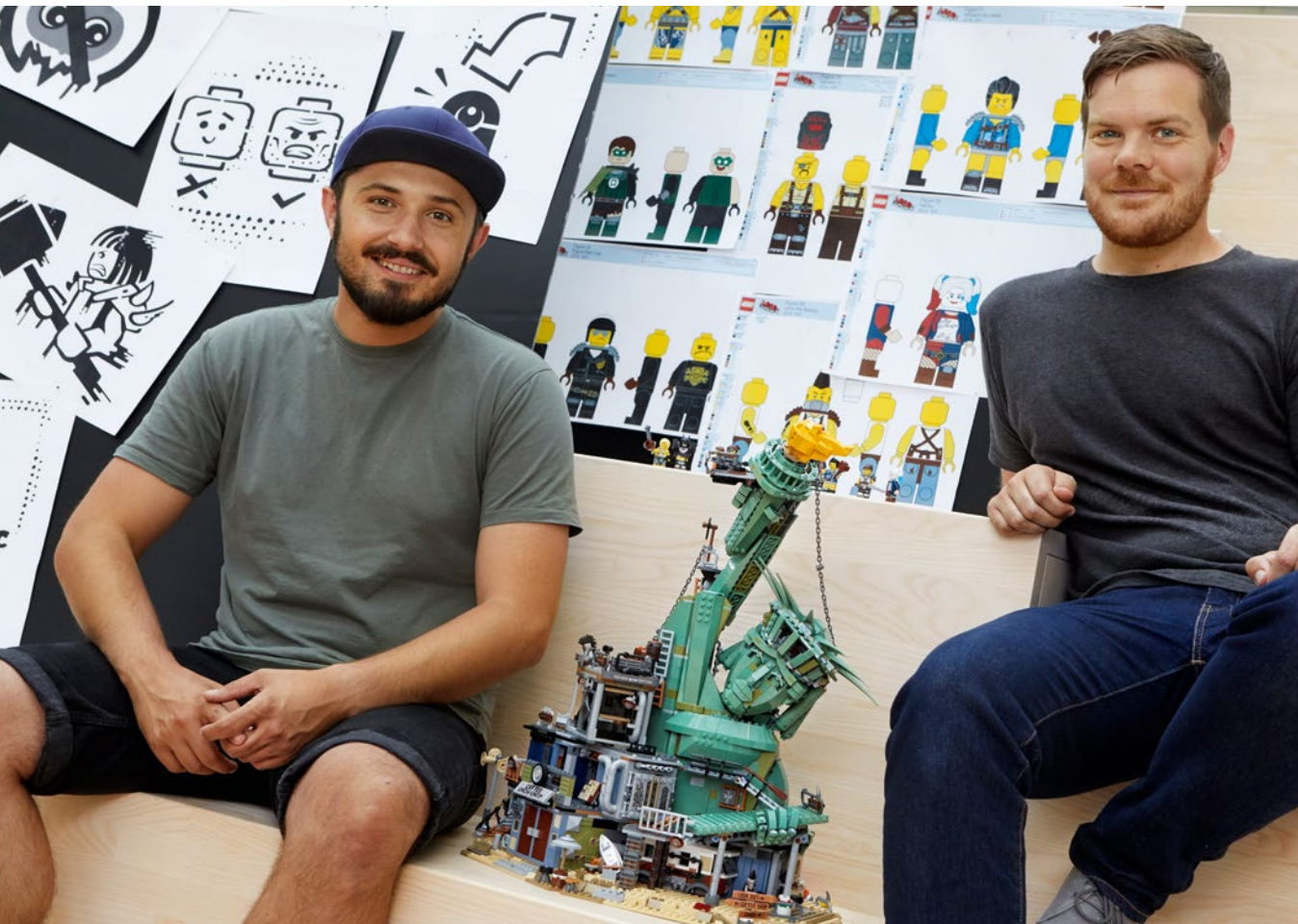

**What were your jobs as Graphic Designers on this set?**

**Mike:** We worked with Justin Ramsden (Senior Model Designer) to help design the decoration stickers for the model - 51 in total - as well as the minifigure characters. **Paul:** Both the main characters and the extras have a rougher look than what you saw in the first movie. We designed the main characters first, and then we created a variety of template torsos and legs that the Warner Bros. Studio team could mix and match to create extras.

**What was the design process like for you for this set?**

**Paul:** We went to Los Angeles to meet with the animators and designers at the movie studios early in the process, and they provided us with references, film clips, animatics, etc. Together we came up with a whole list of ideas for details that would help define this world and the characters in it. And then we kept bouncing ideas back and forth; we had weekly check-ins with the studios and fine-tuned the designs together.

**Mike:** We'd been working on the movie for nearly two years before we started designing the decorations specifically for this set, so we had a good idea what we wanted to do. Together with Justin, we would highlight areas that needed decoration. We'd then use the style guide and all our reference material and assets to create Apocalypseburg as accurately as possible.

**What sources of inspiration did you have?**

**Paul:** Our main goal was to show off each character's personality and their part in the story. Every little detail you see in their costumes and in the model itself was chosen with that in mind. We used the first movie as a starting point, but the mood in the sequel is a bit more up in age, so the look and feel had to reflect that newfound seriousness and darkness. Dystopia - but with the familiar LEGO® humour, of course. **Mike:** The teams at Warner Bros. Studios encouraged us to be creative and come up with our own designs as well. So there are lots of hidden secrets to discover in this set! We managed to sneak in a few references to pop culture and other LEGO movies, like THE LEGO BATMAN™ MOVIE and THE LEGO NINJAGO® MOVIE.

**What is your favourite feature or function in the model?**

**Mike:** For a model that looks quite intimidating in size, it's actually surprisingly easy to take apart and access the interior. You can separate it into sections and play with them individually. **Paul:** It's really hard to pick a favourite! The overall look and concept of a destroyed Statue of Liberty as a makeshift home for minifigures is so funny. And I love all the hidden Easter eggs and surprises.

# How to lift the model



## EMMET

Still as positive and perky as ever, Emmet continues to believe that "Everything is Awesome!" despite living in the most 'heckish' place imaginable: 'Apocalypseburg'. Oblivious to the hardships of residing in this crumbling, dystopian wasteland, Emmet loves to start his day with a trip through town to pick-up his coffee order (one black and one with a touch of cream and 25 sugars) for Lucy and himself. Incapable of mustering a single grim thought, Emmet dreams of 'Rebuilding the Future' and has secretly built the perfect home for his 'special' best friend!



## LUCY

Once a rebel fighting for a noble cause, Lucy's only mission now is fighting to survive! After enduring countless attacks from the DUPLO® Aliens, Lucy is now hardened and battle-ready. Keeping lookout from her surveillance tower on the torch of a crumbling Statue of Liberty, Lucy spends her time narrating her own grim thoughts while awaiting the next onslaught from those relentlessly greedy DUPLO invaders! Despite her dark and brooding demeanour, she still cares deeply about Emmet, but she is beginning to question whether he is tough enough to survive these troubling times.



## BATMAN™

Self-presumed leader of 'Apocalypseburg', Batman has no problem fitting into this darker, grittier world that now surrounds him! Kitted out in his custom-forged Battle armour, he arrogantly proclaims 'This apocalypse looks good on me!' Perched above his purpose-built bat-bunker, Batman™ directs the 'battle cars' to attack. When they once again roll back defeated, he is there to ultimately swoop in and save the day! "You're Welcome!"



### HARLEY QUINN™

This tricky troublemaker has ditched the 'Rogues' of gritty Gotham and now ganged-up with the rag-tag ruffians of Apocalypseburg! Harley is fitting in well – she is pretty handy with a baseball bat, so she's great at keeping those brick-munching baddies at bay. Harley admits she has been tied up in some crazy capers in her time... but Emmet's rescue plan sounds like an absolute 'suicide mission'!



### GREEN LANTERN™

Not exactly the sharpest tool in the Justice League toolbox, Green Lantern™ is always with the best intentions – but having lost his power-ring in all the post-apocalyptic chaos, that hand isn't particularly useful anymore! Not letting that minor issue dissuade him, Green Lantern loves to tag along for the ride and latches onto 'the League' so he can hang with his Super-buddies at any opportunity (whether they want him to or not)!



### SCRIBBLE COP

President Business may have wiped the smile off Good Cop's face in THE LEGO® MOVIE™, but he wouldn't get much use out of that smile here in Apocalypseburg anyhow... There isn't a trace of Good Cop left, so Scribble Cop's head now swivels from 'bad' to 'scribbled'. He has also reverted to his old, bad habit of furniture flinging and chair kicking. Grrrrr!!!!



### CHAINSAW DAVE

Laid-back no longer, 'Surfer Dave' now goes by the gnarly name 'Chainsaw Dave'! Those sketchy DUPLO® Aliens have wiped out any opportunity for him to surf, so dried-up Dave is letting out his frustrations by getting choppy with a chainsaw rather than ripping through the waves!



### LARRY THE BARISTA

Long gone are the days when Larry could charge \$37 for an 'over-priced' coffee. Larry is now the chief proprietor and head barista for 'Coffee Un-chained', where his sole job is serving the civilians of Apocalypseburg with 'the bitter liquid that provides the only semblance of pleasure left in these dark times!'



### "WHERE ARE MY PANTS?" GUY

Permanently pant-less "Where are my pants?" Guy still hasn't tracked down his missing pants – and now that the world has descended into chaos, his search hasn't gotten any easier. In between DUPLO® invasions, "Where are my pants?" Guy can be found sifting through piles of rubble in the quest to find his pesky pants!



### MO-HAWK

Just as prickly as she looks, this spiky civilian has a point to prove and she is not going to rest until she has poked those annoying aliens right back to wherever they came from!



### FUSE

This masked warrior has the shortest fuse of the gang. There is no messing with him – one false move and he is gonna blow!



### ROXXI

This bruiser isn't afraid to stand her ground and is ready for a bit of rough and tumble if anyone dares to attack her town!

## MIKE MITCHELL

Réalisateur

*Apocalypseburg est un endroit difficile, sauvage et dur pour vivre. Cette ville est conçue pour contraster avec Bricksburg, la ville vive et amusante du FILM LEGO®. Notre Apocalypseburg poussiéreux montre comment nos personnages ont lutté pendant des années après l'invasion DUPLO®. Il démontre également comment Finn, le frère aîné à l'origine de l'histoire du premier film, grandit et change son sens du jeu.*



## TRISHA GUM

Coréalisatrice

*Nous voulions que la statue de la Liberté soit le point central de la citadelle. De nombreux films catastrophes utilisent une version en ruines de cette statue emblématique pour souligner la gravité de la destruction subie par le monde... Nous voulions utiliser ce trope et le parodier dans notre film.*



## MATTHEW ASHTON

Producteur exécutif / Vice-président de la conception chez le Groupe LEGO

*L'architecture désordonnée d'Apocalypseburg a été conçue pour suggérer que les personnages ont réutilisé les restes et les débris de leur ville détruite, Bricksburg. Les tons de terre poussiéreux et les nuances pâles ont été utilisés pour créer un contraste avec la seule force positive qui restait dans la citadelle, Emmet, une lueur d'espoir orange et brillante, qui continue à croire que « Tout est SUPER GÉNIAL ! » malgré l'endroit désolant dans lequel il doit vivre.*



### Comment LE FILM LEGO® 2 est-il lié au FILM LEGO ?

LE FILM LEGO® 2 débute exactement où le premier film se termine, avec l'invasion DUPLO®, quand la petite sœur descend au sous-sol pour jouer avec son frère Finn et s'amuser avec l'exposition LEGO géante de leur père. Le film saute ensuite quelques années, et nous nous retrouvons après l'attaque DUPLO, dans la citadelle de fortune d'Apocalypseburg, qui a été grossièrement construite avec les débris de Bricksburg. Après des années de bataille pour défendre leur nouveau royaume, tous nos héros préférés sont devenus difficiles, aguerris, et plus nerveux... sauf bien sûr Emmet, qui refuse d'avoir un regard négatif sur la vie. Jusqu'à ce qu'apparaisse un vaisseau spatial mystérieux, piloté par la formidable Générale Mayhem ! Elle capture tous ses amis et les amène dans la lointaine galaxie connue comme le « système Systar », ne laissant à Emmet que le choix d'essayer de sauver la bande ! Mais Emmet peut-il s'endurcir et être l'« homme » qu'il pense que Lucy veut qu'il soit ? C'est la question à laquelle seul « LE FILM LEGO 2 » peut répondre !

### Pensez-vous que le modèle reflète bien l'esprit du FILM LEGO 2 ?

Il reflète parfaitement le sentiment du premier acte. Nous avons fait de la statue de la Liberté en ruines le point central du modèle, choisis les scènes les plus emblématiques de l'introduction d'Apocalypseburg et nous les avons intégrées autour de la structure. Justin Ramsden (le concepteur du modèle) a fait un travail spectaculaire en agrandissant ce que vous voyez dans le film, en créant des logements individuels pour chacun des personnages, tout en y ajoutant des détails et des accessoires amusants liés à leur personnalité.

### Quelle est votre caractéristique ou votre fonction préférée dans le modèle ?

J'adore la silhouette spectaculaire du modèle dans son intégralité. Il est vraiment impressionnant et sera absolument génial à exposer. L'interprétation de la statue est parfaite, et je pense que les fans apprécieront réellement la modularité astucieuse conçue dans la construction et comment chaque compartiment peut être enlevé pour que vous parveniez à voir les détails incroyables. Je suis également très heureux que nous ayons été en mesure d'inclure un choix de personnages de DC Comics dans cet ensemble, une version post-apocalyptique tout équipée de LEGO Batman™, Green Lantern™ et Harley Quinn™.



# Bienvenue à Apocalypseburg !

Lorsque nous avons quitté Emmet et ses meilleurs copains en briques à la fin du FILM LEGO®, il était l'homme le plus doux et le plus optimiste qu'on pouvait rencontrer. Dans LE FILM LEGO 2, l'éternel optimisme et les compétences de maître-constructeur d'Emmet ont été mis à l'épreuve : Bricksburg est en ruines, et tout le monde essaie de survivre dans le chaos qui a suivi. L'avenir du jeu lui-même est en danger.

Apocalypseburg est la nouvelle ville d'Emmet, à l'aspect désordonné. Refabriquée avec des parties de la maintenant défunte Bricksburg, le modèle comprend 3 178 briques et 12 figurines. Il a tout le chaos, l'action et l'humour post-apocalyptiques pour te permettre de recréer certaines de tes scènes de film préférées, ainsi que quelques lieux supplémentaires. Et, bien sûr, il ne serait pas complet sans les techniques de construction imaginatives qui poussent tes briques LEGO vers de nouvelles limites. Découvre des références cachées et des surprises, des fonctions et des détails amusants alors que tu construis et joues, et tu peux même étendre le jeu avec tes propres idées créatives et concepts. Le sort d'Apocalypseburg est entre tes mains !

Rencontre l'équipe à l'origine du modèle. Comment l'harmonieuse Bricksburg s'est-elle transformée en ce désert sinistre qu'est Apocalypseburg ? Comment Lucy, Batman™ et tous tes autres personnages préférés se sont-ils adaptés à la baisse dramatique du niveau de vie ? Et où peuvent-ils même prendre un café aujourd'hui ? Découvre-le dans les entretiens avec les réalisateurs du film et les concepteurs LEGO.





# Un endroit près du café

étaient tous très ouverts pour ajouter autant d'idées, de blagues et de références que nous pouvions inclure.

## Combien d'esquisses de ce modèle avez-vous faites avant d'atteindre la version finale ?

En équipe, nous avons dessiné et imaginé plusieurs versions différentes, et le modèle a évolué du début à la fin. Certaines versions ne comprenaient pas la statue de la Liberté mais représentaient d'autres parties d'Apocalypseburg, et certaines ont été utilisées pour aider à créer des scènes du film. Il est amusant de regarder en arrière et de comparer le concept de modèle final avec l'ensemble terminé.

## Quelles ont été les caractéristiques les plus difficiles et les plus importantes ?

Il était important de conserver les proportions et angles dramatiques, ce qui signifiait qu'il était essentiel d'obtenir l'échelle correcte. Trouver l'équilibre était un défi amusant. Je voulais qu'il soit crédible que les personnages vivent là, tout en conservant le sentiment qu'une statue massive menaçait. La partie la plus difficile était de créer les angles d'inclinaison et l'aspect « pointu partout », tout en veillant à ce que l'ensemble puisse être construit de façon robuste. Il a fallu un peu de maths, de tests et de discussions pour trouver comment soutenir la torche de la statue et sa tête en biais sans aucun support vertical. Pythagore a sauvé la situation encore une fois ! C'est toujours amusant de repousser les limites du système LEGO. Heureusement, Justin a trouvé comment rendre possible la construction des angles et comment en faire un bon ensemble LEGO. Il a parfaitement réussi.

## Quels sont vos détails favoris dans le modèle ?

Ooh... La maison secrète pour les bébés d'égout est juste hilarante. Et les divers œufs de Pâques que nous avons inclus. Vous pouvez chercher des petits indices pour le gag récurrent selon lequel Batman™ ne s'est peut-être pas encore remis de sa relation avec Lucy. Nous avons essayé d'inclure beaucoup d'espaces de vie pour les figurines dans l'ensemble, comme un endroit en haut pour que Lucy ressasse ses idées noires. L'idée d'un café dans cet environnement est tellement drôle pour moi, parce que vraiment, que FAIT un café dans un décor post-apocalyptique ?

## JOEL DAVID BAKER

Créateur de concepts chez le Groupe LEGO  
Questions et réponses avec Joel

### Quelle a été la partie la plus amusante de la conception de ce nouveau modèle ?

L'attitude et le style du désert post-apocalyptique étaient incroyablement amusants à construire. Il était intéressant d'essayer de capturer son aspect « à peu près bricolé », tout en créant un modèle LEGO® robuste. La partie que j'ai préféré construire a été la tête de la statue de la Liberté avec les détails de sa couronne et son expression stoïque.

### Que fait un créateur de concepts au sein du Groupe LEGO qui est différent des autres concepteurs ?

Nous nous concentrons sur la création de nouvelles idées et sur la communication de ces idées. Parfois, l'idée est transposée dans une version dessin ou numérique ; c'est parfois un gribouillage rapide avec quelques mots sur une note ! Il peut s'agir de nouveaux thèmes, d'un nouvel ensemble ou même de nouveaux éléments. Nous discutons des différentes idées, choisissons celles à construire comme des concepts de modèle et puis nous choisissons notre favori pour l'affiner et en faire un ensemble LEGO. C'est un effort très collaboratif. Ce type de conception signifie construire à partir de zéro avec beaucoup de passion, un peu de recherche et des tonnes d'inspiration.

### Quelles sources d'inspiration aviez-vous ?

Une grande partie de l'inspiration est venue du travail avec Patrick Hanenberger (concepteur de la production) et les artistes concepteurs et animateurs, nos merveilleux réalisateurs Mike Mitchell et Trisha Gum et nos brillants rédacteurs et producteurs Phil Lord et Chris Miller. Ils



De gauche à droite/de haut en bas Joseph Richard Coleman - Concepteur principal | Karina Schanz - Spécialiste principale des données | Stine Mosgaard - Responsable adjointe du marketing | Joel David Baker - Créateur de concepts | Martin Højen Holm Buk - Spécialiste des instructions de montage | Michael Patton - Graphiste | Justin Ramsden - Concepteur principal | Pat M. Madsen - Directrice de projet | Henk van der Does - Responsable principal de modèles | Paul Constantin Turcanu - Graphiste principal | Maria Bloksgaard Markussen - Responsable du marketing | Mette Vraa - Directrice du marketing | Mauricio Bedolla - Responsable principal de la conception

# JUSTIN RAMSDEN

Concepteur principal de modèles  
chez le Groupe LEGO

Questions et réponses avec Justin



## Qu'est-ce qui a été le plus amusant dans la conception de ce nouveau modèle ?

Nous avons eu tellement d'avantages géniaux en travaillant avec le studio de cinéma (par exemple, les esquisses, les versions numériques d'Apocalypseburg et les animations du film), tout en ayant la liberté créative pour développer la narration du film. Cependant, le plus amusant pour moi dans le modèle a été la conception des bâtiments autour de la statue. Ces petites constructions ont traversé de nombreuses étapes et passé de nombreux tests pour savoir ce qui fonctionnait et ce qui ne fonctionnait pas. J'ai pris les éléments existants et essayé de penser comment ils pouvaient être utilisés dans ce monde post-apocalyptique. Par exemple, un vieux camion a formé un bain à remous, un wagon de train est devenu un gym (pour « s'entraîner »...) et

un conteneur a été transformé en salon de coiffure : des endroits que nous ne voyons pas dans le film mais qui selon moi pourraient exister dans ce monde.

## Comment avez-vous raffiné le concept de modèle de Joel ?

Le concept de modèle de Joel était un excellent point de départ. J'ai pris son croquis initial, renversé un bac immense d'éléments LEGO®, retroussé mes manches et j'ai commencé à construire. L'objectif principal était de voir jusqu'où je pouvais améliorer le concept de modèle et créer une expérience de jeu complète à 360 degrés qui a aussi capturé les icônes de son homologue sur écran. Nous voulions que les gens se laissent charmer par Apocalypseburg, et je voulais également inclure autant de détails que possible pour ajouter encore plus de

profondeur aux personnages et aux scènes que les fans pourraient rejouer. J'ai travaillé avec les modèles physiques et numériques et j'ai fini par créer une trentaine d'esquisses différentes, faisant version après version jusqu'à ce que j'arrive au produit final. Construire le visage de la statue de la Liberté a été particulièrement délicat, surtout en utilisant principalement des pièces angulaires pour créer des courbes organiques. Souvent, quand on est en train de faire autre chose, par exemple de cuisiner à la maison, on pense tout à coup à une solution. « Comment peut-on construire les sourcils ? » C'est peut-être pourquoi j'ai pensé à utiliser les éléments de hot-dog.

## Y a-t-il des éléments nouveaux dans l'ensemble que les fans devraient chercher ?

Nous avons créé quelques éléments étonnants pour *LE FILM LEGO 2*, y compris les nouvelles pièces d'armure et une perruque. Batman™ a vraiment profité de ce nouveau mode de vie à Apocalypseburg et a une nouvelle armure super cool faite de vieux pneus. Les fans de LEGO apprécieront aussi sans doute toutes les briques sable et vert olive dans l'ensemble. Nous avons également réussi à ramener l'élément de fil de fer barbelé pour cet ensemble, je sais que certains fans accueilleront son retour avec joie !

## Quelle est la fonction que vous préférez dans le modèle ?

Ma fonction de jeu préférée dans le modèle est une fonction de coup de pied dans une chaise : c'est une référence à une scène dans *LE FILM LEGO* où Méchant Flic perd son sang-froid et donne un coup de pied à une chaise qui vole à travers la pièce. Elle sert aussi d'outil contre le stress pour libérer toute frustration...

## Si vous viviez dans Apocalypseburg, où serait votre maison ? À quoi ressemblerait-elle ?

Vous me trouveriez fouillant les déserts d'Apocalypseburg et utilisant des pièces LEGO trouvées dans des véhicules et des bâtiments détruits pour réaliser de nouvelles et intéressantes créations... !



# MICHAEL PATTON ET PAUL CONSTANTIN TURCANU

Michael Patton /Graphiste chez le Groupe LEGO

Paul Constantin Turcanu /Graphiste principal chez le Groupe LEGO

Questions et réponses avec Mike et Paul

# Capturer tous les détails

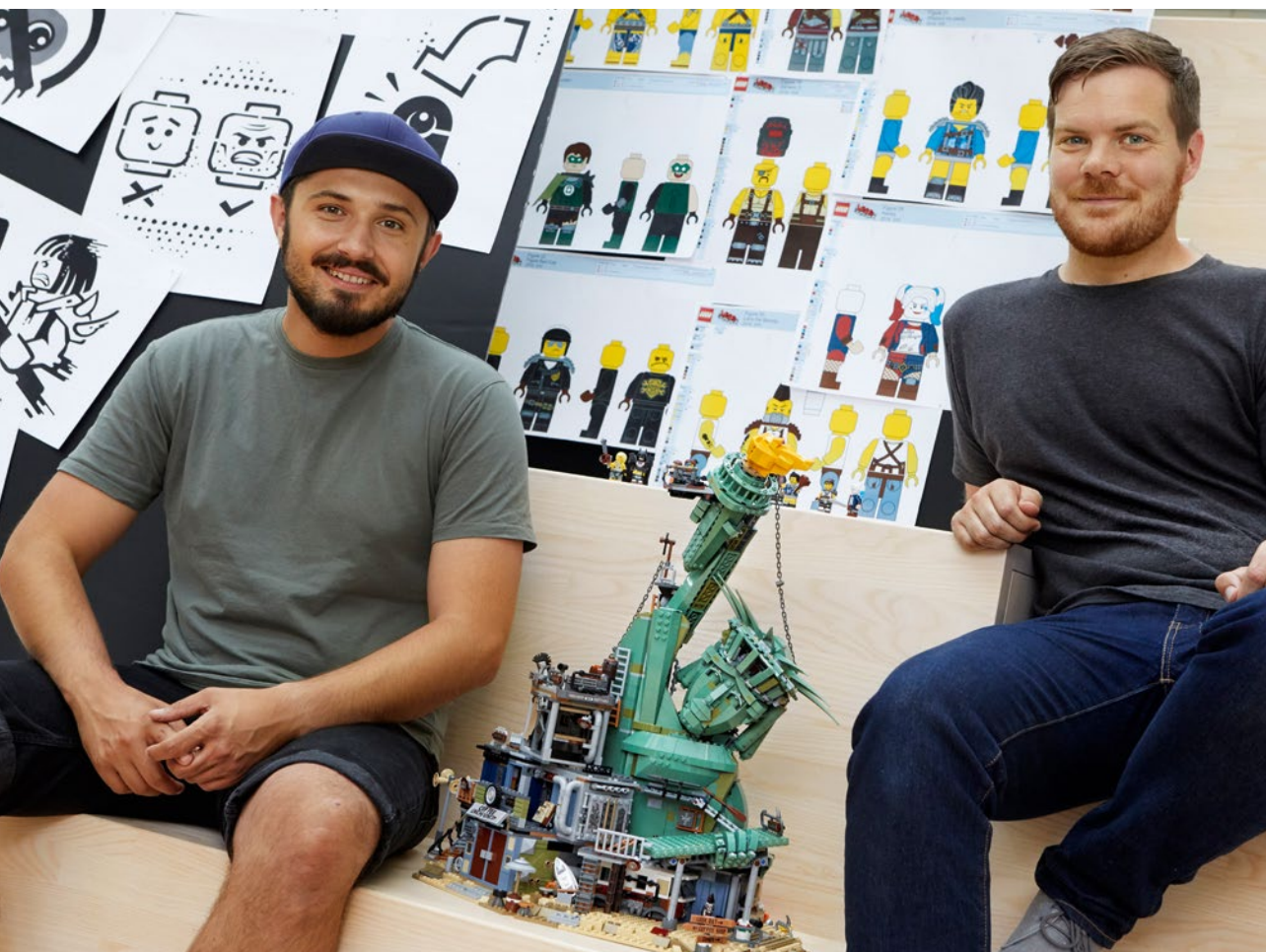

**Quels ont été vos travaux comme graphistes sur cet ensemble ?**

**Mike :** Nous avons travaillé avec Justin Ramsden (le concepteur du modèle) pour aider à concevoir les autocollants de décoration pour le modèle (51 au total) ainsi que les figurines. **Paul :** Les personnages principaux et les figurants ont un aspect plus dur que ce que vous avez vu dans le premier film. Nous avons conçu les personnages principaux, tout d'abord, et puis nous avons créé divers modèles de torsos et de jambes que l'équipe de Warner Bros. Studio pouvait mélanger et assortir pour créer des figurants.

**Comment a été le processus de conception pour vous dans cet ensemble ?**

**Paul :** Nous sommes allés à Los Angeles pour rencontrer les animateurs et les concepteurs dans les studios de cinéma tôt dans le processus, et ils nous ont fourni des références, des séquences filmées, des animations, etc. Nous avons créé ensemble toute une liste d'idées de détails qui aideraient à définir ce monde et les personnages qui y habitent. Et puis nous avons continué de jouer avec les idées. Nous avons eu des contacts hebdomadaires avec les studios et affiné les concepts ensemble. **Mike :** Nous avons travaillé sur le film pendant près de deux ans avant de commencer à concevoir les décorations spécifiquement pour cet ensemble, nous avions donc une bonne idée de ce que nous voulions faire. Avec Justin, nous soulignons les endroits nécessitant une décoration. Nous utilisons ensuite le guide de style, tous nos documents de référence et nos ressources pour créer Apocalypseburg aussi précisément que possible.

**Quelles sources d'inspiration aviez-vous ?**

**Paul :** Notre principal objectif était de montrer la personnalité de chaque personnage et son rôle dans l'histoire. Chaque petit détail que vous voyez dans les costumes des personnages et dans les modèles eux-mêmes a été choisi en pensant à cela. Nous avons utilisé le premier film comme point de départ, mais le ton dans la suite est un peu plus âgé, donc l'aspect et l'ambiance devaient refléter cette gravité et cette noirceur. Une dystopie, mais avec l'humour LEGO® familier, bien sûr. **Mike :** Les équipes de Warner Bros. Studios nous ont encouragés à faire preuve de créativité et à créer aussi nos propres concepts. Donc, il y a beaucoup de secrets cachés à découvrir dans ce jeu ! Nous avons réussi à faufiler quelques références à la culture pop et aux autres films LEGO, comme LEGO BATMAN™ LE FILM et LEGO NINJAGO® LE FILM.

**Quelle est votre caractéristique ou votre fonction préférée dans le modèle ?**

**Mike :** Pour un modèle qui a une taille assez intimidante, il est en fait étonnamment facile à démonter pour accéder à l'intérieur. Vous pouvez le séparer en sections et jouer avec celles-ci individuellement. **Paul :** C'est vraiment difficile de choisir un favori ! Le look et le concept d'une statue de la Liberté détruite utilisée comme une maison improvisée pour les figurines est si drôle. Et j'aime tous les œufs de Pâques et les surprises cachés.

# Comment soulever le modèle



## EMMET

Toujours aussi positif et joyeux, Emmet continue de croire que « Tout est super génial ! » bien qu'il vive dans l'endroit le plus « infernal » possible : Apocalypseburg. Inconscient des difficultés pour vivre dans ce désert dystopique en ruines, Emmet adore commencer sa journée avec un voyage à travers la ville pour aller chercher un café (un noir et l'autre avec un soupçon de crème et 25 sucres) pour Lucy et lui. Incapable d'avoir une seule pensée sinistre, Emmet rêve de « Reconstruire l'avenir » et a construit secrètement la maison parfaite pour son meilleur ami « spécial » !



## LUCY

Jadis une rebelle luttant pour une noble cause, la seule mission de Lucy est maintenant de lutter pour survivre ! Après avoir enduré d'innombrables attaques des extraterrestres DUPLO®, Lucy est maintenant endurcie et prête au combat. Surveillant depuis sa tour de guet sur le flambeau d'une statue de la Liberté qui s'écroule, Lucy passe son temps à raconter ses pensées sombres en attendant l'assaut suivant des envahisseurs DUPLO impitoyablement avides ! Malgré son attitude sombre et mélancolique, elle tient beaucoup à Emmet, mais commence à se demander s'il est assez fort pour survivre à cette période difficile.



## BATMAN™

Se présument chef d'« Apocalypseburg », Batman n'a aucun problème à s'adapter à ce monde plus sombre et plus difficile qui l'entoure maintenant ! Équipé de son armure de combat forgée et personnalisée, il proclame avec arrogance : « Cette apocalypse me va bien ! » Perché au-dessus de son bat-bunker spécialement construit, Batman™ dirige les « voitures de combat » pour attaquer. Quand elles reculent, vaincues une fois de plus, il est là pour finalement intervenir et sauver la situation ! « De rien ! »



### HARLEY QUINN™

Cette agitatrice redoutable a laissé tomber les escrocs de Gotham et s'est maintenant alliée avec les voyous hétéroclites d'Apocalypseburg ! Harley s'adapte bien, elle est plutôt douée avec un bâton de baseball, elle est donc excellente pour maintenir à distance ces grignoteurs de briques. Harley admet qu'elle s'est retrouvée dans quelques coups bizarres par le passé... mais le plan de sauvetage d'Emmet semble être une vraie « mission suicide » !



### GREEN LANTERN™

Pas exactement l'outil le plus fort dans la boîte à outils de la Ligue des justiciers, Green Lantern™ a toujours les meilleures intentions, mais ayant perdu son anneau de puissance dans le chaos post-apocalyptique, cette main n'est plus particulièrement utile ! Ne laissant pas ce problème mineur le dissuader, Green Lantern aime suivre et s'accrocher à « la Ligue », pour traîner avec ses super copains à toutes les occasions (qu'ils le veuillent ou non) !



### FLIC GRIBOILLÉ

Président Business a peut-être enlevé le sourire du visage du Gentil Flic dans *LE FILM LEGO®*, mais son sourire ne lui serait pas utile à Apocalypseburg de toute façon... Il ne reste aucune trace du Gentil Flic, donc la tête de Flic Gribouillé passe maintenant de « méchant » à « gribouillé ». Il est également revenu à sa vieille mauvaise habitude de malmener les meubles et de donner des coups de pieds aux chaises. Grrrrrrr !!!!



### DAVE TRONÇONNEUSE

« Dave le surfeur » n'est plus détendu et s'appelle désormais « Dave Tronçonneuse » ! Ces extraterrestres DUPLO® sournois ont anéanti toute occasion pour lui de surfer, alors Dave exprime ses frustrations en s'agitant avec une tronçonneuse plutôt que sur les vagues !



### LARRY LE BARISTA

Les jours pendant lesquels Larry pouvait faire payer 37 \$ pour un café « surévalué » ont disparu depuis longtemps. Larry est maintenant le propriétaire et le chef barista du « Café dé-chaîné », où son unique tâche est de servir les civils d'Apocalypseburg avec « le liquide amer qui fournit le seul semblant de plaisir qui reste en ces temps sombres ! »



### M. OÙ EST MON PANTALON

En permanence sans pantalon, M. Où est mon pantalon n'a pas encore trouvé son pantalon manquant, et maintenant que le monde est plongé dans le chaos, sa recherche n'est pas devenue plus facile. Entre les invasions DUPLO®, M. Où est mon pantalon peut être trouvé fouillant dans les tas de décombres à la recherche de ce pantalon agaçant !



### MO-HAWK

Tout aussi piquante qu'elle en a l'air, cette citoyenne hérissée a un point à prouver et elle ne va pas se reposer tant qu'elle n'aura pas repoussé ces extraterrestres gênants d'où ils viennent !



### FULMINANT

Ce guerrier masqué a le caractère le plus enflammé de la bande. Il ne faut pas jouer avec lui : un faux mouvement et il explose !



### ROXXI

Cette fière-à-bras n'a peur de rien et est prête à se battre si quelqu'un ose attaquer sa ville !

## MIKE MITCHELL

Director

*Apocalipsburgo es un lugar inhóspito, hostil y peligroso para vivir. Está diseñado para contrastar con la brillante y divertida Ladriburgo de LA GRAN AVENTURA LEGO®. La polvosa Apocalipsburgo es el resultado de la lucha de nuestros personajes durante años luego de la invasión de DUPLO®. También demuestra cómo está creciendo Finn, el hermano mayor que está detrás de la historia de la primera película, y los cambios que está atravesando su sentido del juego.*



## TRISHA GUM

Codirectora

*Queríamos que la Estatua de la Libertad fuera el corazón de la ciudadela. Con mucha frecuencia, las películas sobre catástrofes usan una versión en ruínas de la conocida estatua para poner de manifiesto la gravedad de la destrucción a la que se ha enfrentado el mundo. Queríamos poner en escena esa imagen y parodiarla en nuestra cinta.*



## MATTHEW ASHTON

Productor ejecutivo/vicepresidente de diseño en The LEGO Group

*La caprichosa arquitectura de Apocalipsburgo se concibió para insinuar que los personajes han reutilizado los restos y escombros de su ciudad, Ladriburgo, ahora devastada. Los polvorientos tonos tierra y las sombras apagadas sirvieron para destacar la única fuerza positiva que queda en la ciudadela: Emmet, un brillante y anaranjado faro de esperanza que sigue creyendo que "¡Todo es INCREÍBLE!" a pesar del agujero en el que ha acabado viviendo.*



### ¿Cómo se conecta la historia de LA GRAN AVENTURA LEGO® 2 con LA GRAN AVENTURA LEGO?

LA GRAN AVENTURA LEGO® 2 comienza en el punto exacto en el que termina la primera película: con la invasión de DUPLO®, que tiene lugar cuando la hermana pequeña baja al sótano para jugar con su hermano Finn en el gigantesco escenario LEGO construido por su padre. La historia avanza entonces unos cuantos años y nos sumerge en las consecuencias del ataque de DUPLO; estamos en la improvisada ciudadela de Apocalipsburgo, crudamente construida a partir de los restos de Ladriburgo. Después de años de lucha en defensa de su nuevo reino, nuestros héroes favoritos se han vuelto insensibles, duros e irritables; a excepción, por supuesto, de Emmet, que se resiste a abandonar su positiva visión de la vida. ¡Hasta que aparece una misteriosa nave espacial pilotada por la formidable General Caos! Secuestra a todos sus amigos y los traslada a la lejana galaxia conocida como "Sistema Syster", ideando a Emmet sin otra opción que la de tratar de rescatar a la banda! ¿Pero podrá Emmet volverse duro y ser el "hombre" que cree que Lucy quiere que sea? ¡Esa es la pregunta que sólo LA GRAN AVENTURA LEGO 2 puede responder!

### ¿En qué medida crees que captura el modelo el espíritu de LA GRAN AVENTURA LEGO 2?

Refleja a la perfección las impresiones del primer acto. Decidimos que la Estatua de la Libertad en ruinas fuera el centro de atención del modelo, seleccionamos las escenas más representativas de la presentación de Apocalipsburgo y las incorporamos alrededor de la estructura. Justin Ramsden (diseñador del modelo) ha hecho un trabajo extraordinario ampliando lo que realmente se ve en la película, creando las casas de los personajes y aportando divertidos detalles y accesorios vinculados a sus personalidades.

### ¿Cuál es tu característica o función favorita del modelo?

Me encanta la dramática silueta que presenta el modelo en su totalidad. Es un verdadero espectáculo y queda absolutamente genial como objeto de exposición. La interpretación de la estatua es muy acertada, y creo que los fans agradecerán la ingeniosa modularidad que incorpora el modelo y el hecho de que se puedan desarmar todos los compartimientos para sumergirse en la escena y apreciar los increíbles detalles. También estoy muy satisfecho de que hayamos podido incluir algunos personajes DC Comics en el set: una versión posapocalíptica de LEGO Batman™ totalmente equipado, Linterna Verde y Harley Quinn™.



# ¡Te damos la bienvenida a Apocalipsburgo!

Cuando dejamos a Emmet y a sus mejores amigos constructores al final de LA GRAN AVENTURA LEGO®, era el tipo más dulce y optimista que pudieras imaginar. En LA GRAN AVENTURA LEGO 2, sin embargo, el eterno optimismo y las habilidades "maestroconstructoras" de Emmet se enfrentan a la prueba más grande de todas: Ladriburgo está en ruinas y todo el mundo se esfuerza por sobrevivir en el caos que esto ha provocado. El futuro del juego en sí está en peligro.

Apocalipsburgo es el nuevo hogar de Emmet, una ciudad de aspecto caprichoso. Reconstruido a partir de la hoy desaparecida Ladriburgo, el modelo se compone de 3178 bricks y 12 minifiguras. Incluye todo el caos posapocalíptico, la acción y el sentido del humor que necesitas para recrear algunas de tus escenas favoritas de la película, así como algunos escenarios extra. Y, por supuesto, no estaría completo sin un par de imaginativas técnicas de construcción para superar nuevos límites con tus bricks LEGO. Descubre referencias ocultas y graciosas sorpresas, funciones y detalles mientras construyes y juegas; incluso puedes ampliar el set con tus propias ideas y diseños creativos. ¡El destino de Apocalipsburgo está en tus manos!

Conoce al equipo responsable del diseño del modelo. ¿Cómo se convirtió la armoniosa Ladriburgo en el desolado y sucio tiradero que es Apocalipsburgo? ¿Cómo se han adaptado Lucy, Batman™ y todos tus otros personajes favoritos a una caída tan drástica del nivel de vida? ¿Dónde pueden siquiera comprar café en estos días? Descúbrelo en las entrevistas con los directores de la película y los diseñadores de LEGO.



# Un lugar cerca de la cafetería

## ¿Cuántas versiones preliminares de este modelo se hicieron antes de alcanzar la versión final?

El equipo hizo varias versiones diferentes y soñó con otras tantas; el modelo evolucionó mucho desde el principio hasta el final. Algunas versiones no incluían la Estatua de la Libertad, sino que representaban partes distintas de Apocalipsburgo, mientras que otras se usaron como material gráfico para contribuir a la creación de las escenas de la película. Es divertido mirar atrás y comparar el modelo conceptual definitivo con el set acabado.

## ¿Cuáles fueron las características más problemáticas y las más importantes?

Era importante mantener las proporciones y los ángulos dramáticos, para lo cual era fundamental dar con la escala correcta. Encontrar ese equilibrio fue un desafío divertido. Quería que fuera creíble que los personajes hubieran vivido allí, sin perder de vista la impresión de que la enorme estatua se elevaba antes sobre ellos. La parte más difícil fue crear los ángulos oblicuos y transmitir la sensación de que todo es imperfecto, garantizando al mismo tiempo que se pudiera construir de forma resistente. Tuvimos que recurrir a las matemáticas, hacer pruebas y debatir un poco para encontrar la forma de sostener la antorcha y la cabeza de la estatua en ángulo sin ningún tipo de apoyo vertical. ¡Pitágoras volvió a ser la solución! Siempre es divertido ir más allá de los límites en lo que respecta al sistema de construcción LEGO System. Afortunadamente, Justin averiguó una forma de construir los ángulos y encontró la manera de incorporarla a un set LEGO como se debe. Acertó por completo.

## ¿Cuáles son tus detalles favoritos del modelo?

Oh, la casa secreta de los bebés del drenaje es graciosísima. También me gustan las sorpresas que hemos incluido. Puedes encontrar pequeñas referencias al chiste recurrente sobre que tal vez Batman™ no haya superado todavía su relación con Lucy. Intentamos incluir en el set muchos espacios habitables para las minifiguras, como el lugar de reflexión para Lucy que se encuentra en la parte superior. El hecho de que haya una cafetería en un entorno como este me parece supergracioso; porque, en serio: ¿QUÉ HACE una cafetería en un escenario posapocalíptico?

## JOEL DAVID BAKER Diseñador conceptual en The LEGO Group Ronda de preguntas y respuestas con Joel

### ¿Qué fue lo más divertido de diseñar este nuevo modelo?

La actitud y el estilo del tiradero posapocalíptico fueron increíblemente divertidos de reflejar. Fue interesante tratar de capturar esa sensación de que todo es muy rudimentario e improvisado y lograr al mismo tiempo que el modelo LEGO® fuera sólido. Lo que más me gustó diseñar fue la cabeza de la Estatua de la Libertad, con los detalles de la corona y su estoica expresión.

### ¿Qué hace un diseñador conceptual en The LEGO Group que no se parezca a nada de lo que hacen los demás diseñadores?

Nos concentramos en generar nuevas ideas y comunicarlas. A veces, la idea se plasma en un dibujo o un modelo digital; otras no es más que un garabato rápido con unas pocas palabras en una nota adhesiva! Pueden ser temas nuevos, un nuevo set o incluso nuevos elementos. Debatimos las diferentes ideas, elegimos las que vale la pena trasladar a un modelo conceptual y, después, seleccionamos nuestras favoritas para pulirlas y convertirlas en sets LEGO. Es una labor muy participativa. Este tipo de diseño implica construir desde cero con mucha pasión, investigar un poco y buscar toneladas de inspiración.

### ¿Cuáles fueron sus fuentes de inspiración?

Mucha de la inspiración surgió de la colaboración con Patrick Hanenberger (diseñador de producción) y los artistas conceptuales y animadores; nuestros maravillosos directores, Mike Mitchell y Trisha Gum; y nuestros brillantes escritores y productores, Phil Lord y Chris Miller. Todos se mostraron muy abiertos a añadir tantas ideas, chistes y referencias como fuera posible.



De izquierda a derecha y de arriba abajo: Joseph Richard Coleman, diseñador sénior | Karina Schanz, experta en datos maestros sénior | Stine Mosgaard, jefa de mercadotecnia asociada | Joel David Baker, diseñador conceptual | Martin Højen Holm Buk, experto en instrucciones de construcción | Michael Patton, diseñador gráfico | Justin Ramsden, diseñador sénior | Pat M. Madsen, directora del proyecto | Henk van der Does, orientador de modelos sénior | Paul Constantin Turcanu, diseñador gráfico sénior | Maria Bloksgaard Markussen, jefa de mercadotecnia | Mette Vraa, directora de mercadotecnia | Mauricio Bedolla, jefe de diseño sénior

# JUSTIN RAMSDEN

Diseñador de modelos sénior  
en The LEGO Group

Ronda de preguntas y respuestas con Justin



## ¿Qué fue lo más divertido de diseñar este nuevo modelo?

El estudio nos proporcionó un montón de recursos excelentes para trabajar (como ilustraciones conceptuales, modelos digitales de Apocalipsisburgo y animaciones cinematográficas), pero también gozamos de libertad creativa para ampliar la historia que cuenta la película. Sin embargo, personalmente, lo que más divertido me pareció de diseñar el modelo fueron las construcciones que hay alrededor de la estatua. Las pequeñas estructuras atravesaron muchas etapas y pruebas destinadas a averiguar lo que funcionaba y lo que no. Partí de elementos que ya existían e intenté imaginar cómo se usarían en un mundo posapocalíptico como este. Por ejemplo, un viejo camión podría haberse convertido en una tina de hidromasaje, un vagón de tren en un gimnasio (por aquello del "entrenamiento") o un contenedor de transporte en una peluquería; ninguno de esos lugares sale

en la película, pero creí que podrían existir en este mundo.

## ¿Cuál fue el proceso para perfeccionar el modelo conceptual de Joel?

El modelo conceptual de Joel fue un magnífico punto de partida. Tomé su versión preliminar, vacié una enorme tina de elementos LEGO®, me puse de rodillas y empecé a construir. Mi principal objetivo era determinar qué tanto podría mejorar el modelo conceptual y crear una experiencia de juego completa desde todos los ángulos que capturara los iconos de su contrapartida cinematográfica. Todos queríamos que la gente se enamorara de Apocalipsisburgo; yo, además, quería incluir tantos detalles como pudiera para aportar aún más profundidad a los personajes y las escenas que los fans quisieran representar. Trabajé tanto con modelos físicos como con construcciones digitales y acabé creando alrededor de treinta versiones

preliminares diferentes, iteración tras iteración, hasta que llegué al producto final. Reproducir el rostro de la Estatua de la Libertad fue particularmente complejo, sobre todo teniendo en cuenta que necesitaba crear curvas orgánicas usando piezas principalmente rectangulares. Con frecuencia, las soluciones se te ocurren de repente, mientras estás haciendo otra cosa, como cocinar en casa. "¿Cómo se podrían construir las cejas?". Tal vez fue eso lo que me llevó a usar elementos que representan salchichas.

## ¿Incluye el set nuevos elementos que puedan interesarles a los fans?

Hemos creado algunos elementos fascinantes para LA GRAN AVENTURA LEGO 2, como nuevas armaduras y una peluca. Batman™ ha sacado mucho provecho de su nuevo estilo de vida en Apocalipsisburgo y cuenta con una nueva y genial armadura fabricada con llantas viejas. Aparte de eso, es probable que los fans de LEGO disfruten mucho también con todos los bricks en colores arena y verde olivo que incluye el set. También logramos traer de regreso el elemento del alambre de púas para este set, ¡lo cual sé que alegrará a unos cuantos fans! ¿Cuál es tu función favorita del modelo? Mi función favorita del modelo es la que permite patear una silla; es una referencia a una escena de LA GRAN AVENTURA LEGO en la que el Policía Malo pierde la paciencia y le da una patada a una silla, que sale volando por la habitación. También sirve como herramienta para liberar el estrés y deshacerse de las frustraciones.

## Si vivieras en Apocalipsisburgo, ¿dónde estaría tu casa?

### ¿Cómo se vería?

¡Me encontrarían hurgando por los tiraderos de Apocalipsisburgo, usando piezas LEGO de edificios y vehículos destruidos para construir nuevas e interesantes creaciones!





# MICHAEL PATTON AND PAUL CONSTANTIN TURCANO

Michael Patton / Diseñador gráfico en The LEGO Group

Paul Constantin Turcano / Diseñador gráfico sénior en The LEGO Group

Ronda de preguntas y respuestas con Mike y Paul

# No podía faltar ningún detalle

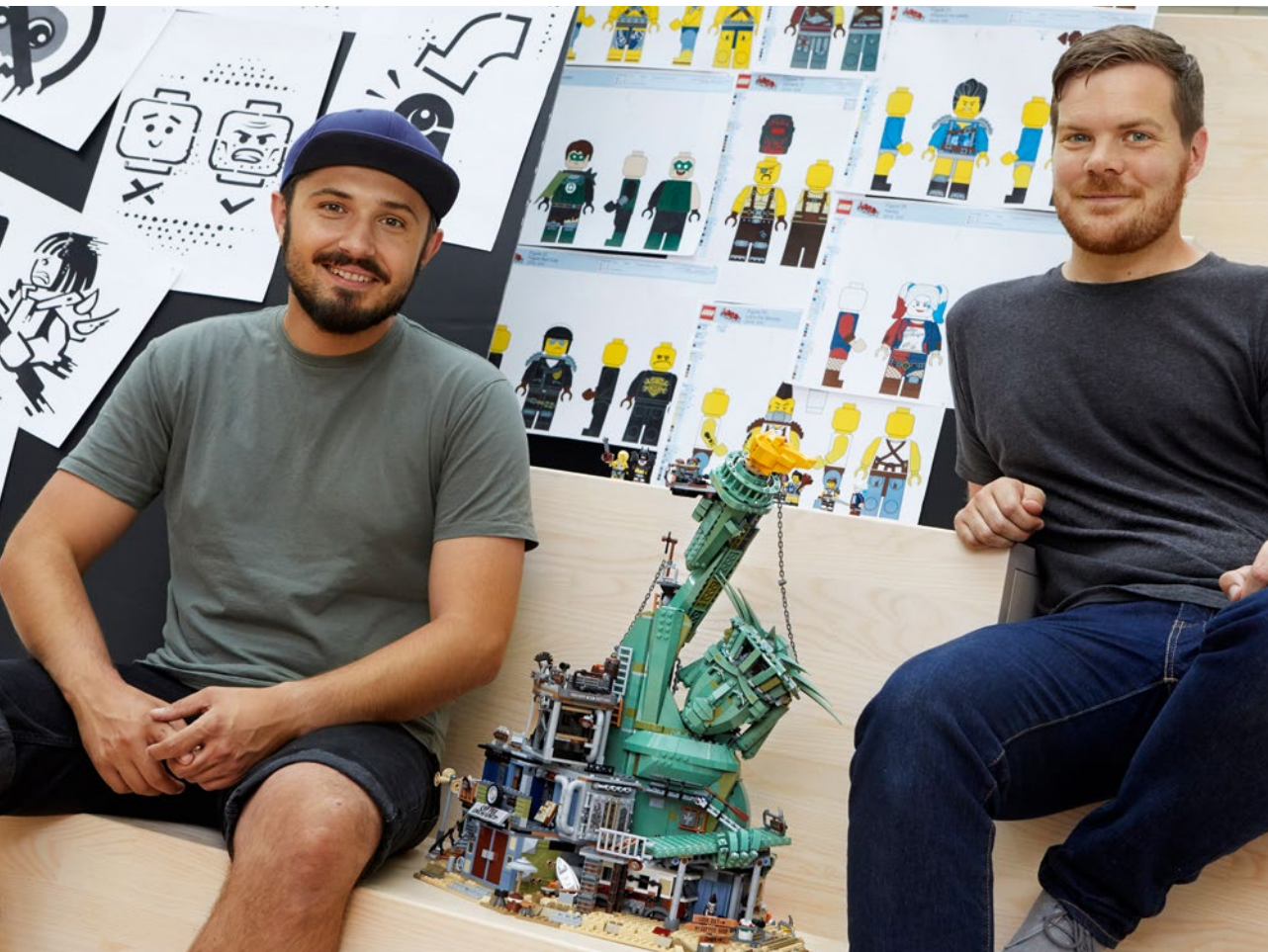

**¿En qué consistió su trabajo como diseñadores gráficos para este set?**

**Mike:** Trabajamos con Justin Ramsden (diseñador del modelo) en el diseño de las calcomanías decorativas del set (51 en total), así como en las minifiguras de los personajes. **Paul:** Tanto los protagonistas como los extras tienen un aspecto más crudo que el que pudimos ver en la primera película. Diseñamos a los protagonistas primero, y luego creamos una serie de torsos y piernas que el equipo de Warner Bros. Studio pudiera mezclar y combinar para crear a los extras.

**¿Cómo fue el proceso de diseño de este set para ustedes?**

**Paul:** Fuimos a Los Ángeles para reunirnos con los animadores y diseñadores en los estudios cinematográficos al principio del proceso, y nos proporcionaron referencias, fragmentos de la película, animaciones, etc. Juntos elaboramos una larga lista de ideas acerca de los detalles que contribuirían a definir este mundo y los personajes que forman parte de él. Después seguimos intercambiando ideas; nos reuníamos una vez a la semana con el estudio y revisábamos los diseños entre todos. **Mike:** Llevábamos casi dos años trabajando en la película cuando empezamos a diseñar los elementos decorativos que acompañarían específicamente a este set, así que ya teníamos una idea clara de lo que queríamos. En colaboración con Justin, determinamos las áreas que necesitaban decoración. Después usamos la guía de estilo y todos nuestros materiales de referencia y recursos para crear Apocalipsisburgo con la máxima precisión posible.

**¿Cuáles fueron sus fuentes de inspiración?**

**Paul:** Nuestro principal objetivo era poner de manifiesto la personalidad de cada personaje y su papel en la historia. Hasta el más mínimo de los detalles que se aprecian en el vestuario y el mismo modelo se eligió teniendo eso en cuenta. Usamos la primera película como punto de partida, pero el humor de la secuela es un poco más maduro, así que las sensaciones que fuera a transmitir el set tenían que reflejar esa nueva seriedad y oscuridad. Distopía, sí; pero con el sentido del humor característico de LEGO®, por supuesto. **Mike:** Los equipos de Warner Bros. Studios nos animaron a ser creativos y desarrollar también nuestros propios diseños. ¡El resultado es un montón de secretos por descubrir en el set! Pudimos colar unas cuantas referencias a la cultura pop y a otras películas de LEGO, como LEGO BATMAN™: LA PELÍCULA y LEGO NINJAGO®: LA PELÍCULA.

**¿Cuál es su característica o función favorita del modelo?**

**Mike:** Para ser un modelo de dimensiones tan espectaculares, en realidad es sorprendentemente fácil desarmarlo y acceder al interior. Las secciones que lo componen se pueden separar para jugar con ellas individualmente.

**Paul:** ¡Es muy difícil elegir sólo una favorita! El aspecto general de la Estatua de la Libertad destruida y el hecho de que las minifiguras la usen como refugio improvisado son ideas muy graciosas. También me encantan los secretos y las sorpresas que esconde el set.

# Cómo levantar el modelo

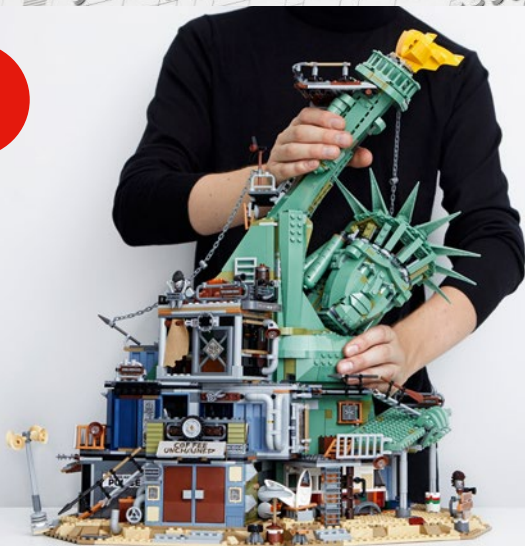

## EMMET

Tan positivo y alegre como siempre, Emmet sigue creyendo que "¡Todo es increíble!", aun viviendo en el lugar más indeseable que se pueda imaginar: Apocalipsisburgo. Indiferente a las dificultades de residir en este desolado tiradero en ruinas, a Emmet le encanta empezar el día con un paseo por la ciudad para recoger su pedido habitual en la cafetería: uno solo (para Lucy) y otro con un toque de crema y 25 cubitos de azúcar (para él). Incapaz de tener un solo pensamiento sombrío, Emmet sueña en secreto la casa perfecta para su mejor amigo "especial"!



## LUCY

Esta antigua rebelde solía luchar por una noble causa. Ahora, la única misión de Lucy es luchar por sobrevivir. Luego de soportar los innumerables ataques de los extraterrestres DUPLO®, Lucy se ha vuelto más dura y está lista para la batalla. Siempre alerta desde su torre de vigilancia, instalada en la antorcha de una Estatua de la Libertad que se cae en pedazos, Lucy se dedica a narrar su propio pesimismo a la espera de la próxima ofensiva de los insaciables y despiadados invasores DUPLO. A pesar de su conducta oscura y melancólica, sigue preocupándose profundamente por Emmet, aunque empieza a preguntarse si es lo suficientemente duro como para sobrevivir a estos tiempos tan turbulentos.



## BATMAN™

Autoproclamado líder de Apocalipsisburgo, Batman™ no tiene ningún problema para adaptarse al nuevo mundo que lo rodea, ipor oscuro y hostil que sea! Equipado con una armadura de combate fabricada a la medida, pregona con arrogancia: "¡Este apocalipsis me queda de maravilla!". Subido al batibúnker que construyó para ello, Batman dirige las maniobras de los "autos de combate" durante los ataques. Cuando regresen derrotados una vez más, él estará ahí para lanzarse en el último momento y salvar el día. "¡De nada!".



### HARLEY QUINN™

Esta astuta buscapietos dejó atrás a los bribones de la sucia Ciudad Gótica y se unió a los andrajosos rufianes de Apocalipsburgo. Y no le va nada mal: es muy hábil con el bate de béisbol, lo cual le permite mantener a raya a esos malvados comebricks. Harley admite que se ha visto envuelta en algunas situaciones descabelladas en sus tiempos... ¡pero el plan de rescate de Emmet le parece una auténtica "misión suicida"!



### LINTERNA VERDE

No es que sea lo mejor de la Liga de la Justicia, pero las intenciones de Linterna Verde siempre son buenas. Aunque, habiendo extraviado su anillo de poder en medio del caos posapocalíptico, ¡esa mano ha perdido casi toda su utilidad! Un pequeño problema por el que Linterna Verde no pierde el ánimo: le encanta apuntarse a cualquier viaje y nunca deja pasar la oportunidad de acoplarse a "la Liga" para pasarla genial con sus superamigos (lo quieran o no).



### POLICÍA GARABATO

Puede ser que el Presidente Negocios le haya borrado la sonrisa de la cara al Policía Bueno en LA GRAN AVENTURA LEGO®, aunque de todas formas tampoco tendría muchas oportunidades de usarla en Apocalipsburgo. No queda rastro del Policía Bueno, así que el Policía Garabato sólo puede cambiar de "malo" a "garabato". También ha retomado su vieja y mala costumbre de lanzar muebles y patear sillas. ¡Grrrrrr!



### DAVE EL MOTOSIERRA

Nunca más relajado, el surfista Dave se hace llamar ahora Dave el Motosierra: ¡qué miedo! Esos extraterrestres DUPLO® tan raritos le han arrebatado toda oportunidad de surfear, así que Dave trata de superar la sequía y calmar sus frustraciones atravesando todo con una motosierra en lugar de surcar las olas.



### LARRY EL MESERO

Atrás quedaron los días en que Larry podía cobrar 37 dólares por un café "sobrealorado". Larry es ahora el jefe de meseros y principal propietario del "Café Sin Cadenas", en donde su único trabajo consiste en servir a los civiles de Apocalipsburgo "ese amargo líquido que proporciona el único espejismo de placer que nos queda en estos tiempos oscuros".



### CHICO SIN PANTALONES

El Chico sin Pantalones, eternamente carente de pantalones, no ha encontrado todavía los pantalones que perdió; y ahora que el mundo está sumido en el caos, su búsqueda no será para nada más sencilla. ¡Entre las invasiones de DUPLO®, el Chico sin Pantalones se dedica a escarbar entre los escombros en busca de esos malditos pantalones!



### MO-HAWK

Tan espinosa como parece, esta puntiaguda civil tiene algo que demostrar y no piensa descansar hasta que haya hecho regresar a esos extraterrestres tan pesados al lugar de donde vinieron, ¡sea cual sea!



### FUSE

Este guerrero enmascarado es el miembro de la banda con la mecha más corta. No te pases con él: ¡un movimiento en falso y explotará!



### ROXXI

¡Esta fiera no tiene miedo de defender su territorio y está lista para dar y recibir si alguien se atreve a atacar su ciudad!

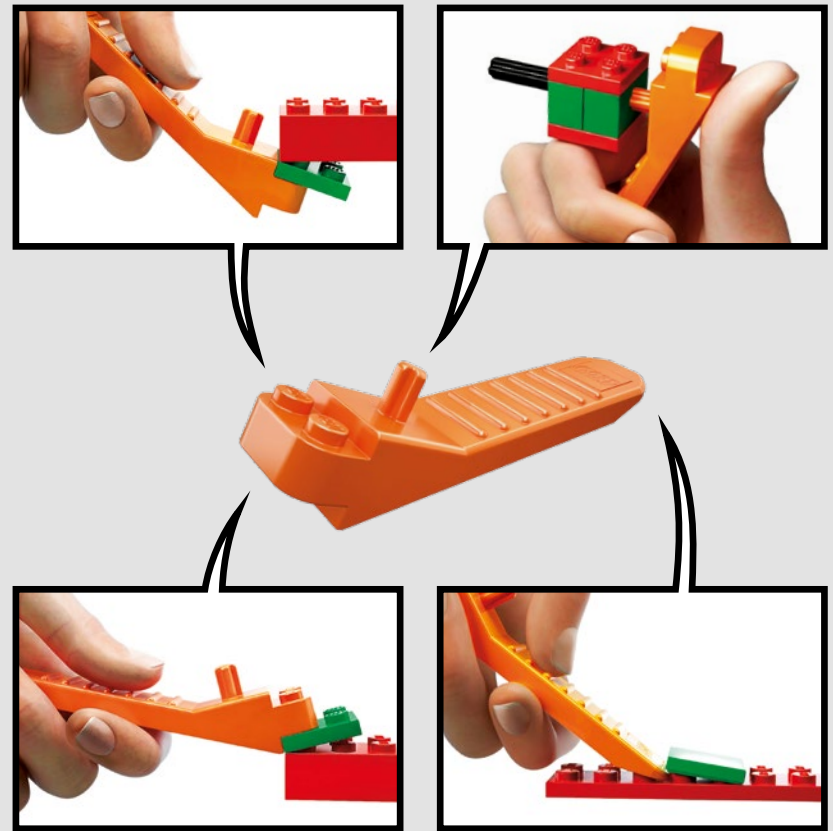
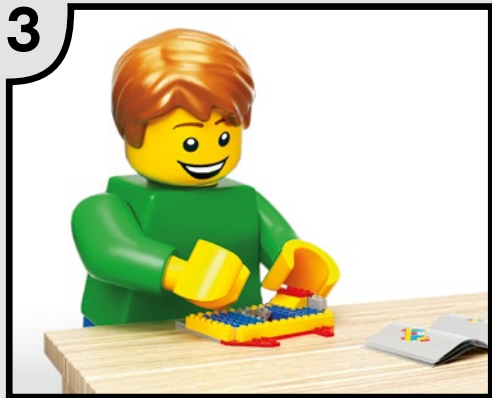

[LEGO.com/brickseparator](http://LEGO.com/brickseparator)



1



2

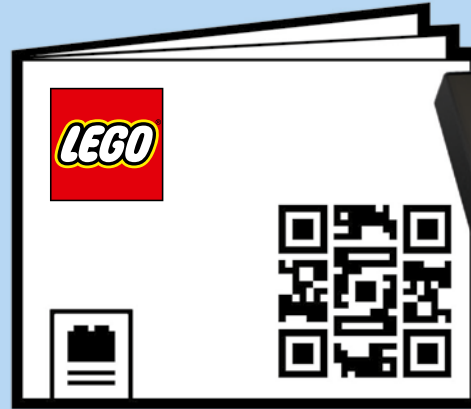

3

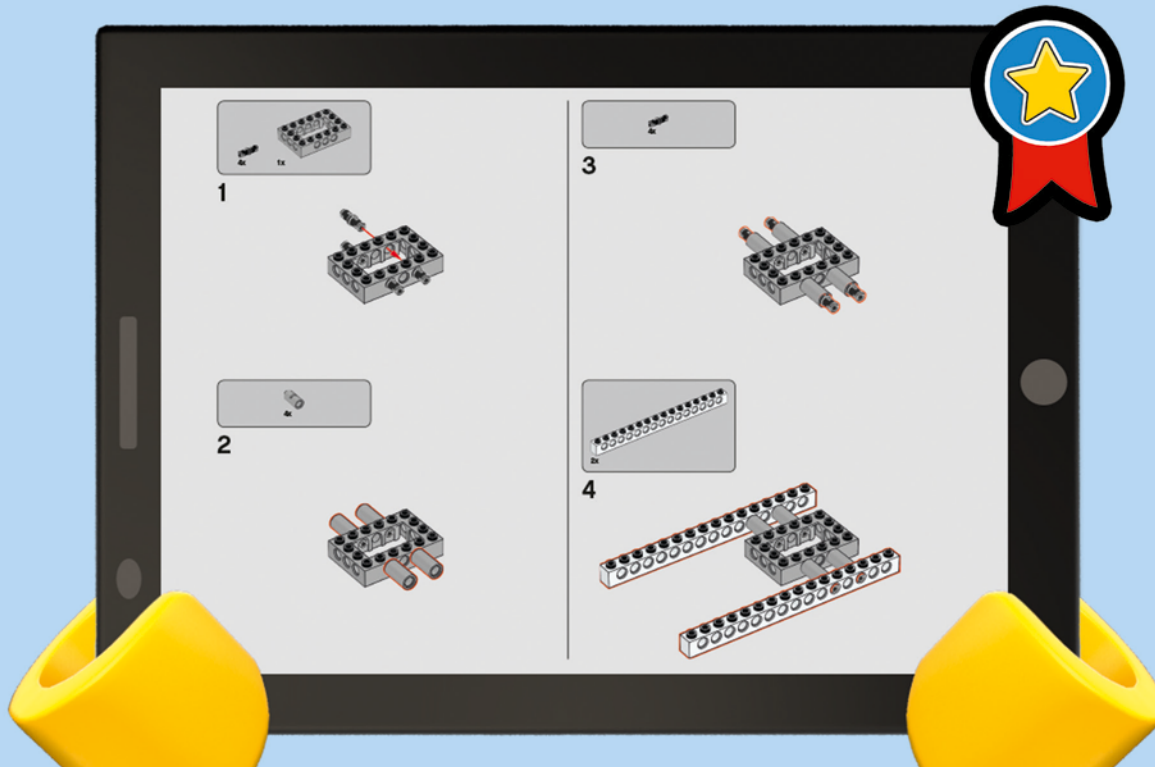

**LEGO.com/apps**

Check for compatibility  
Vérifier la compatibilité  
Comprueba tu compatibilidad

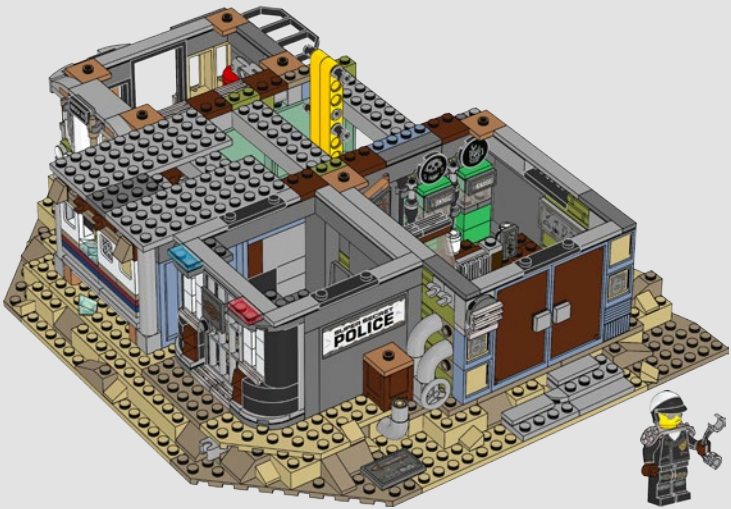
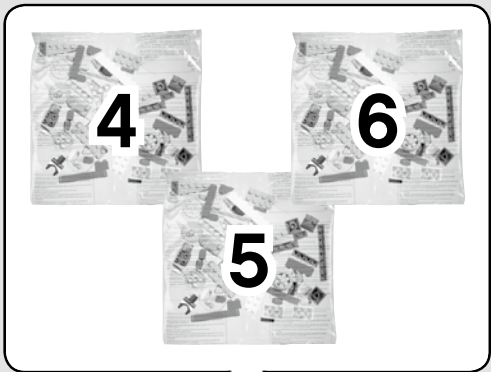
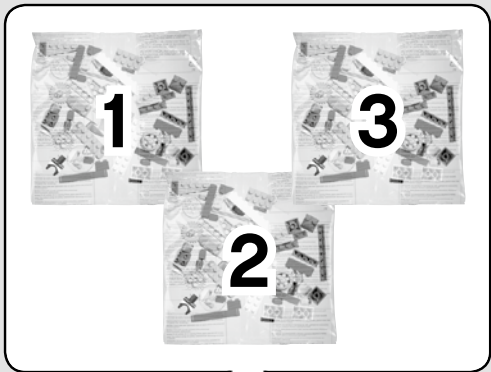

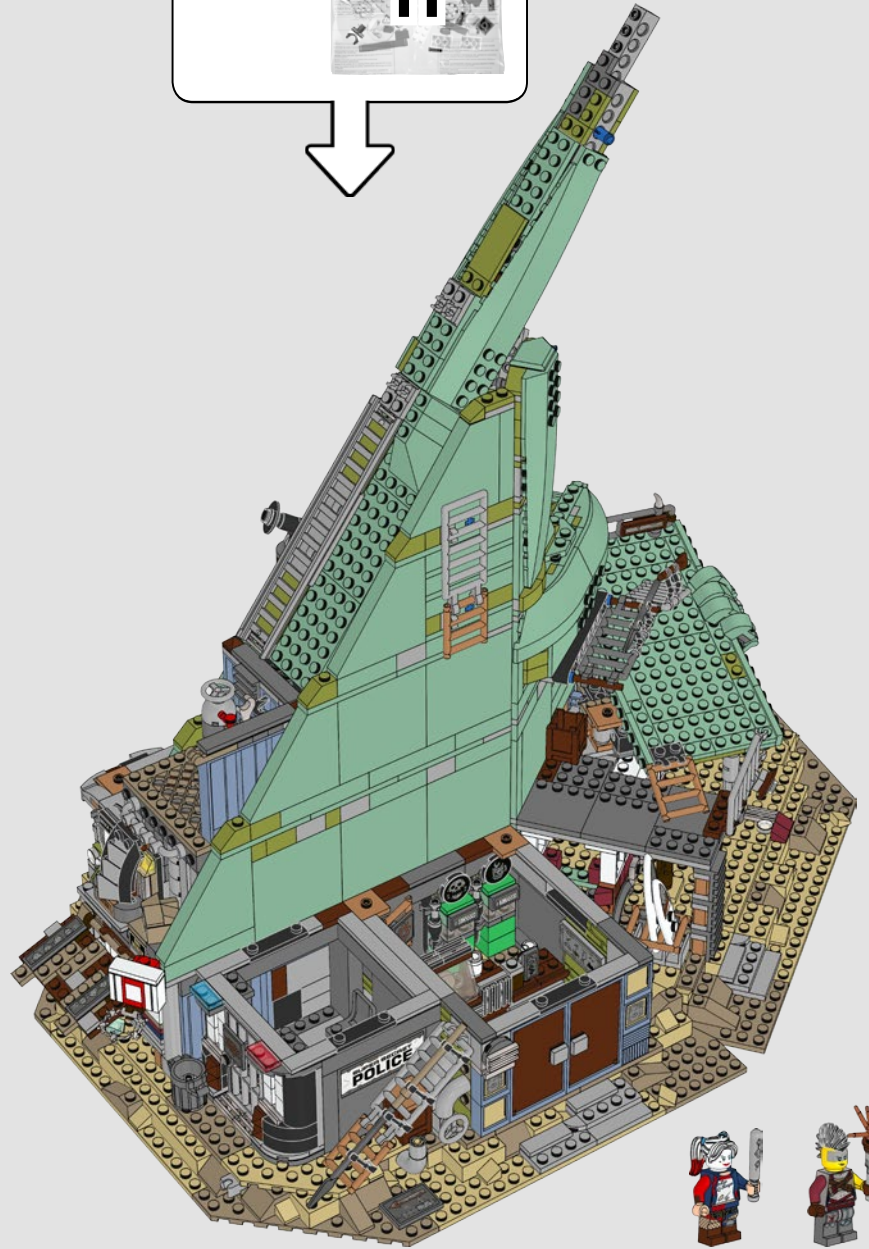
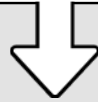
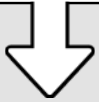
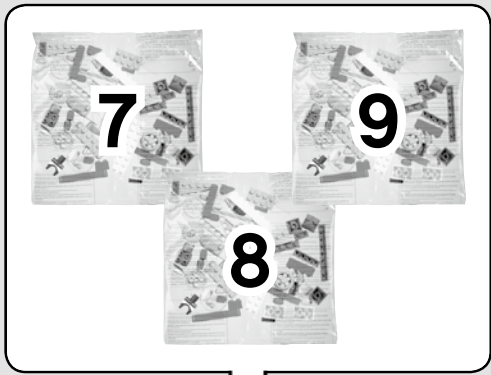

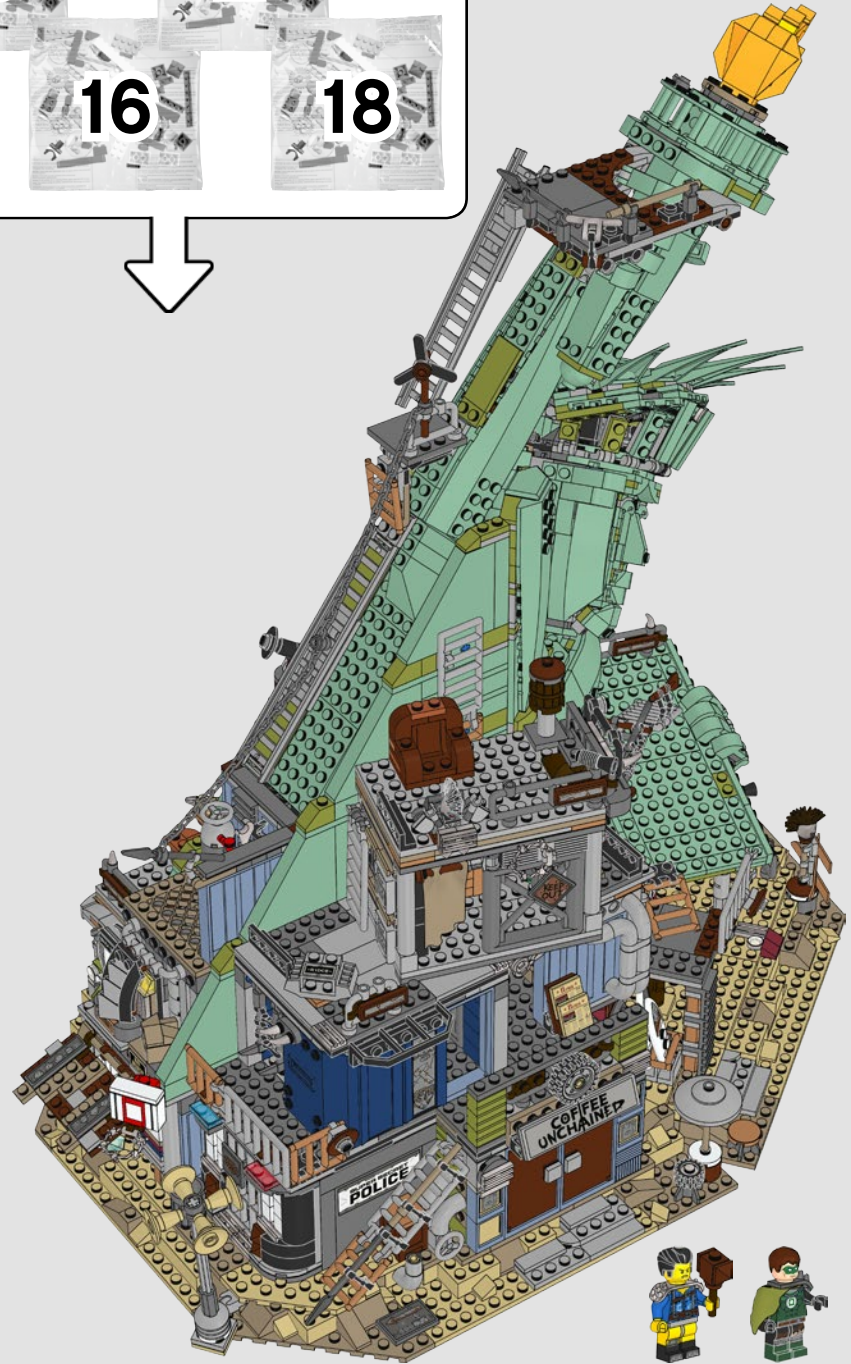
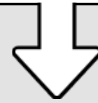
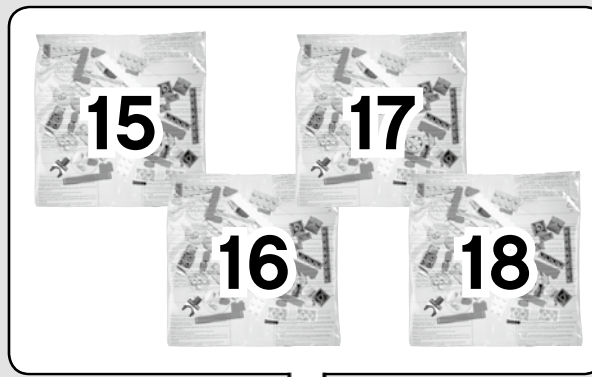
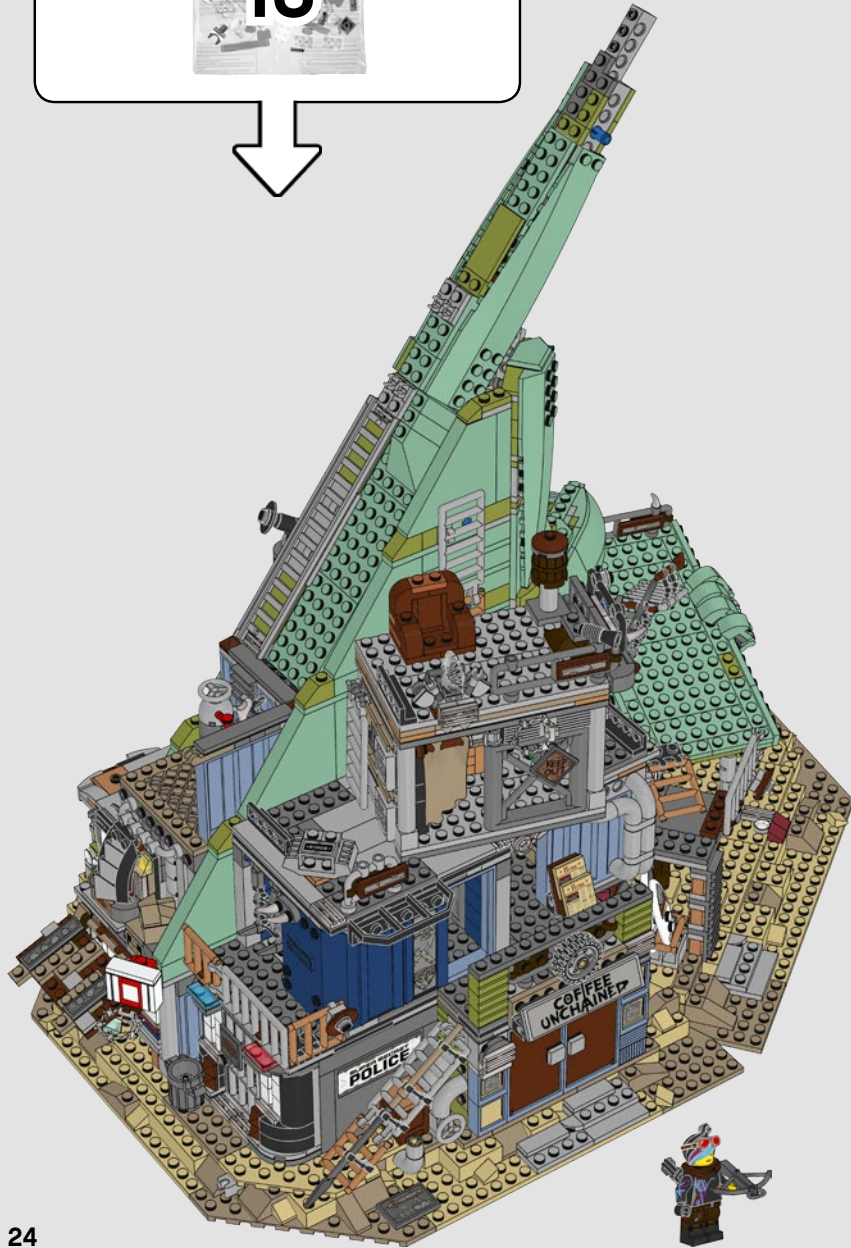
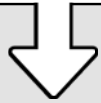



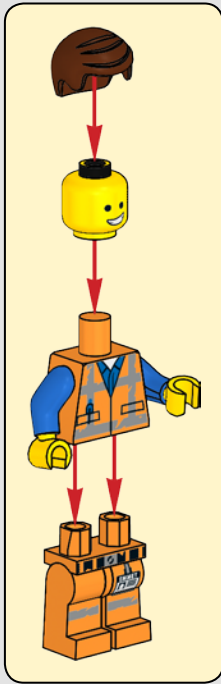
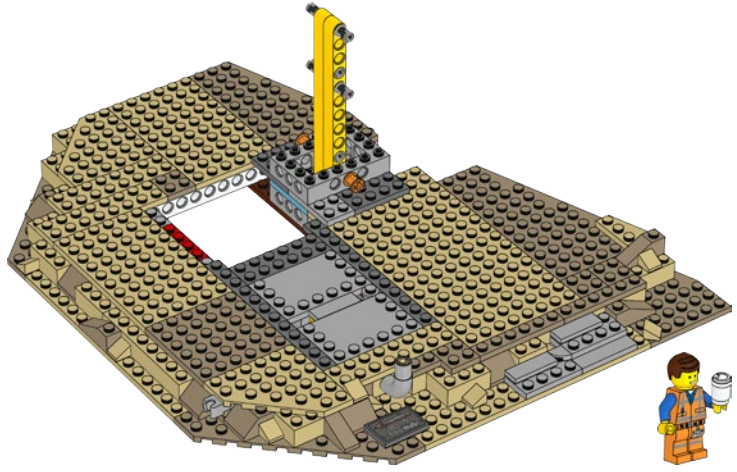
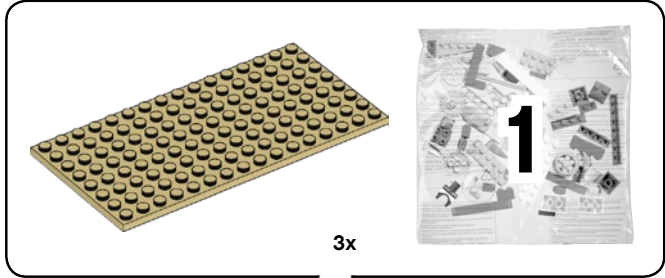

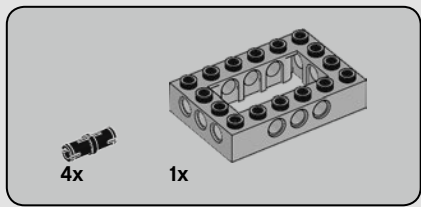

1

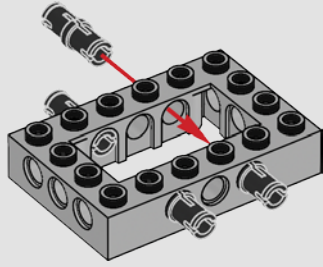

2

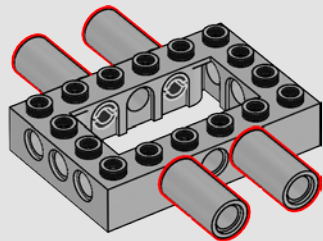

3

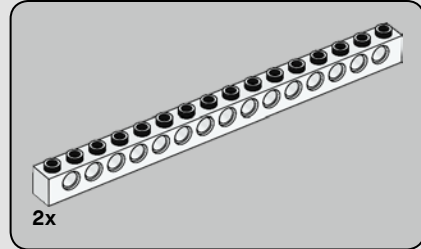
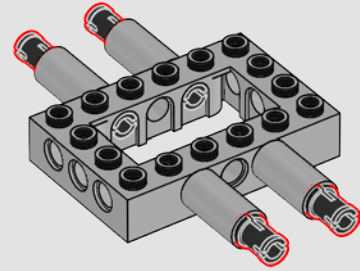

4

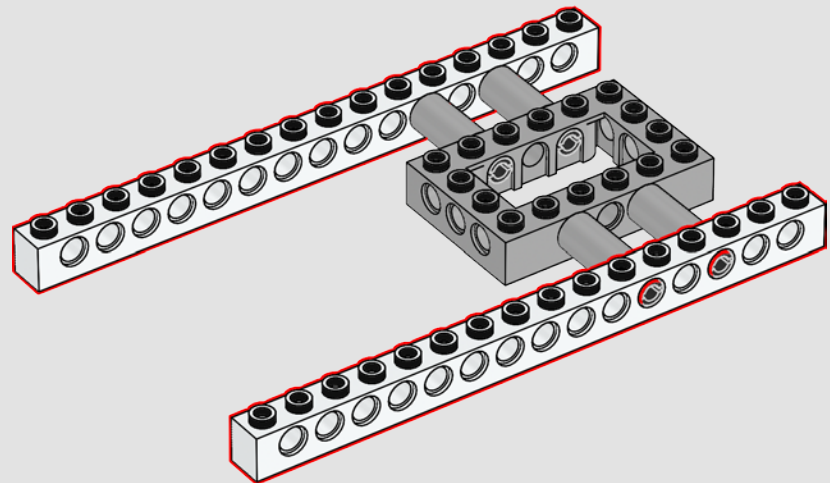

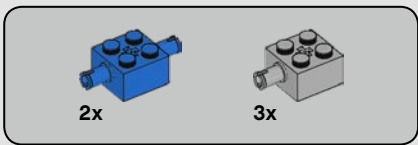

5

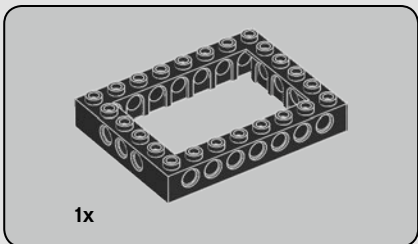
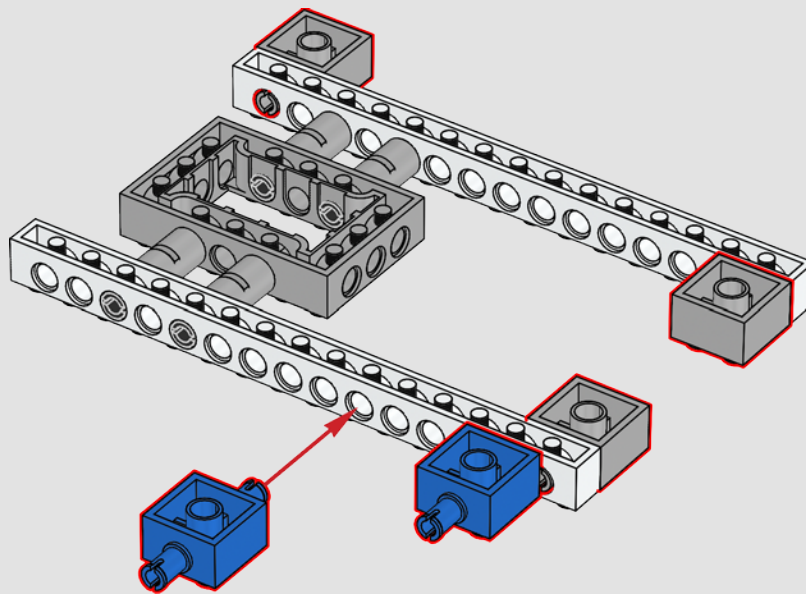
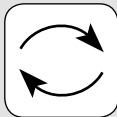

6

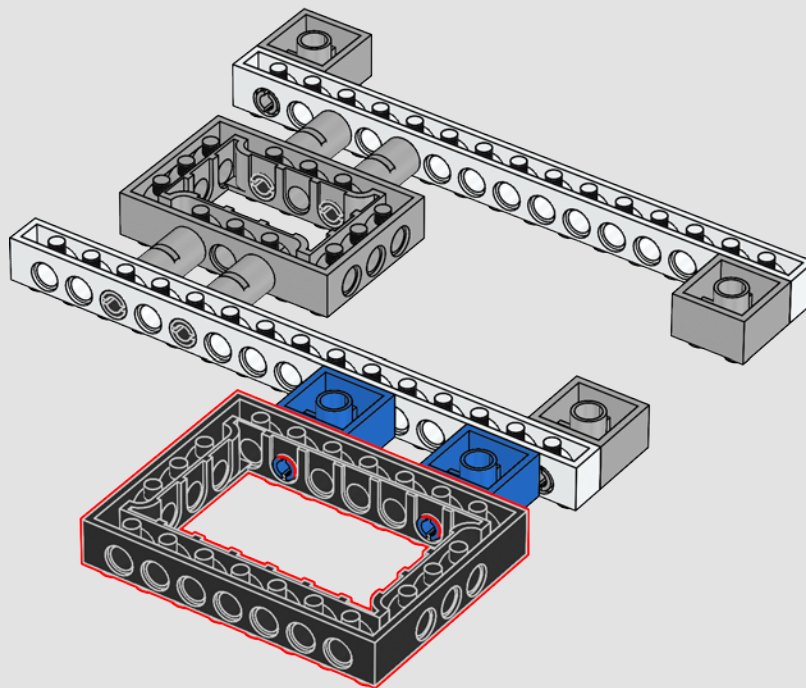

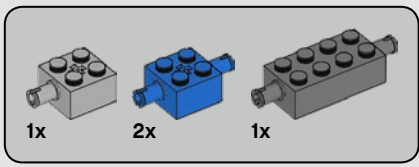

7

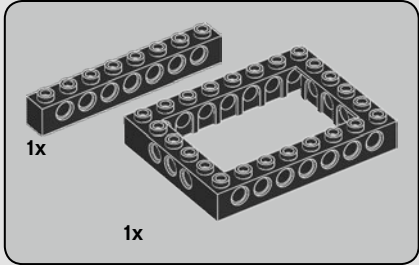
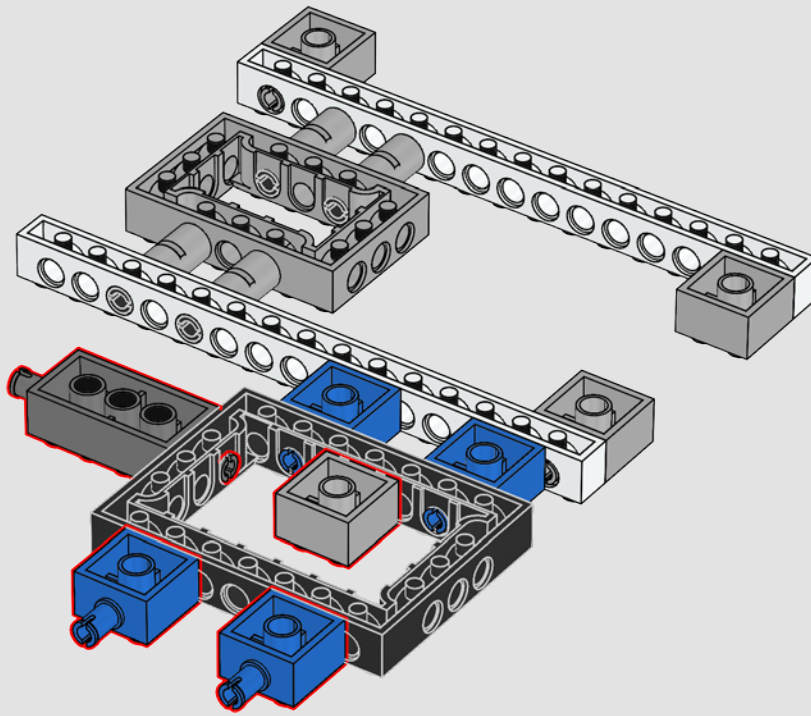

8

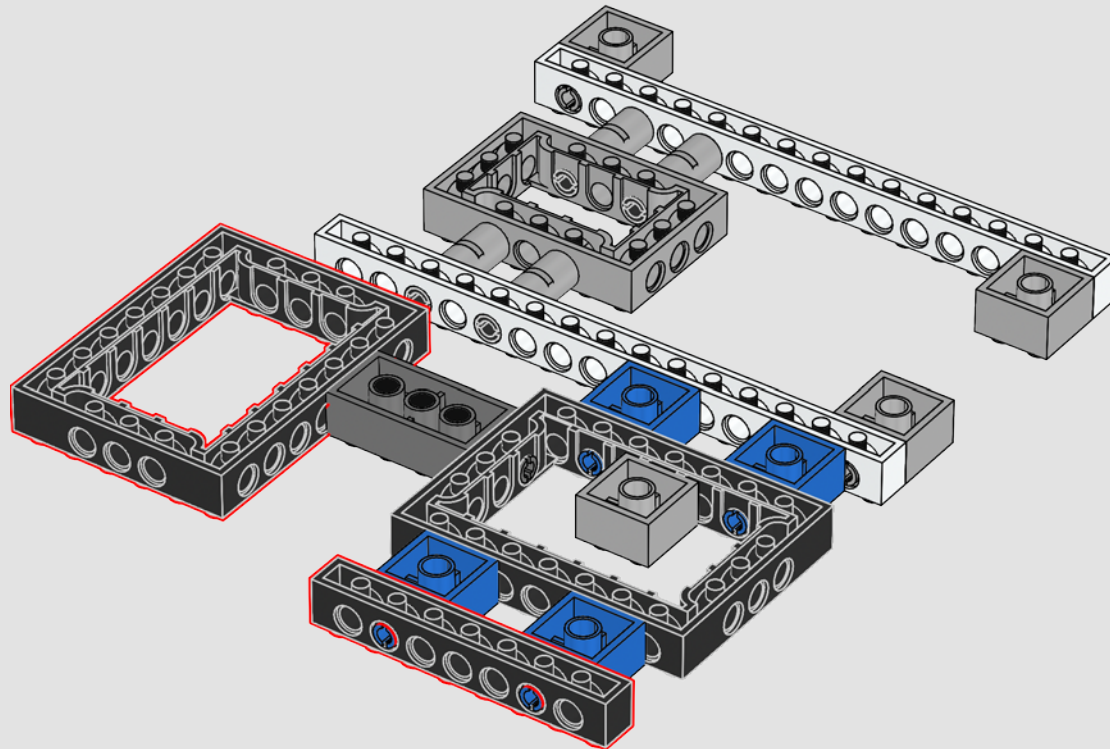

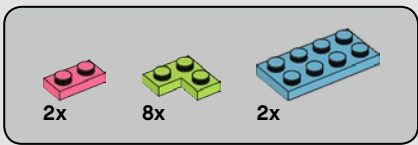

9

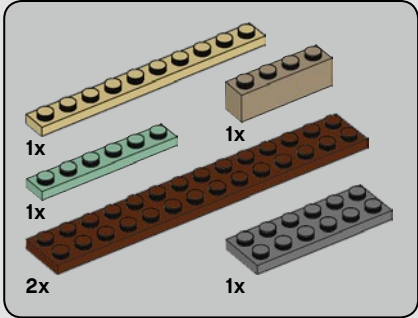
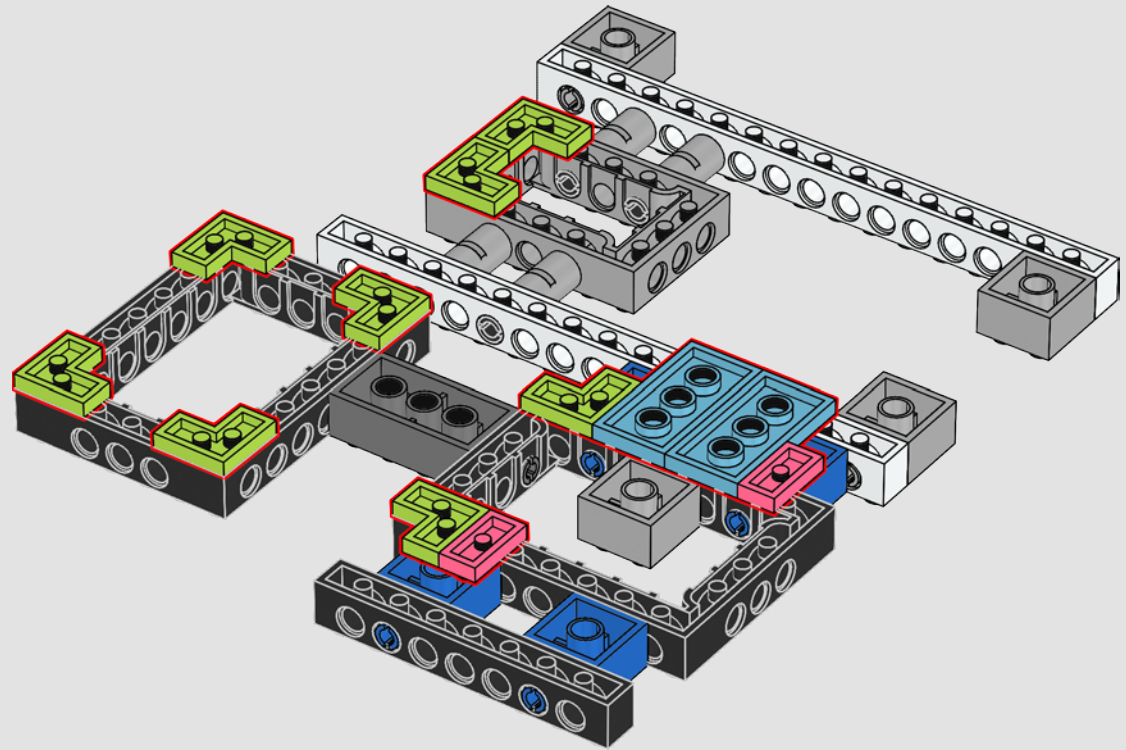

10

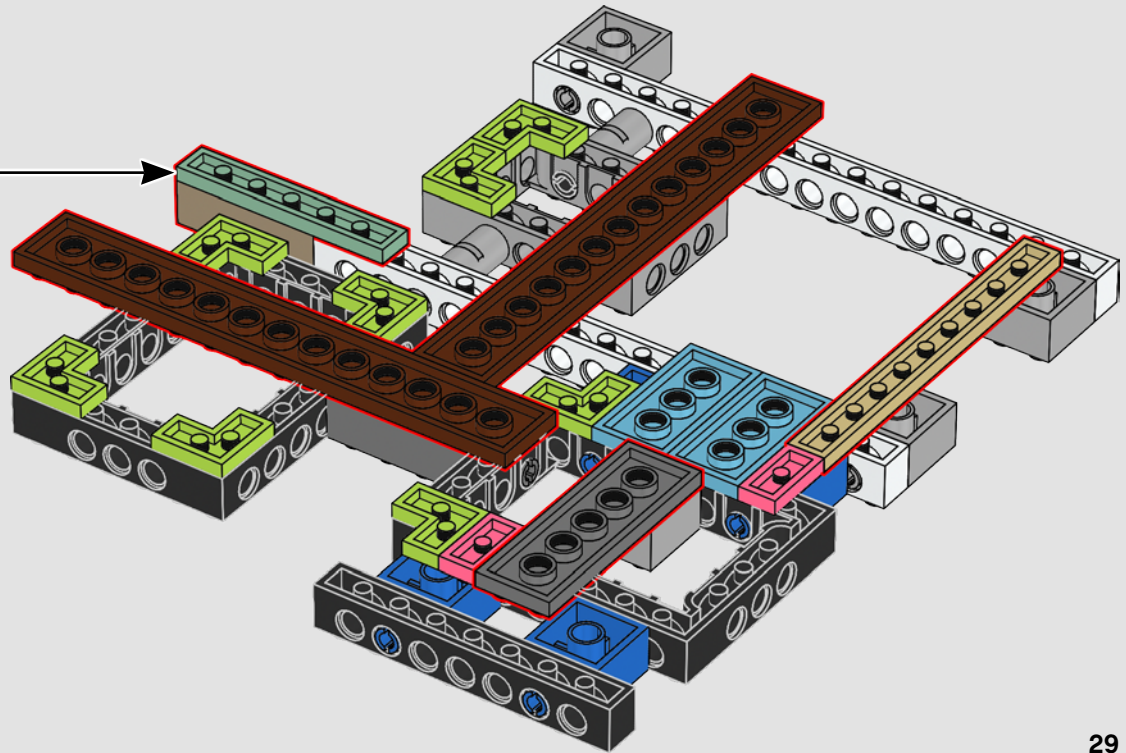
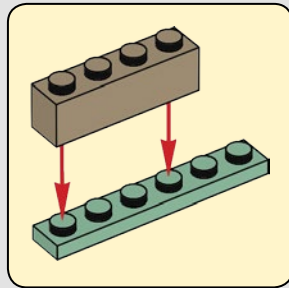

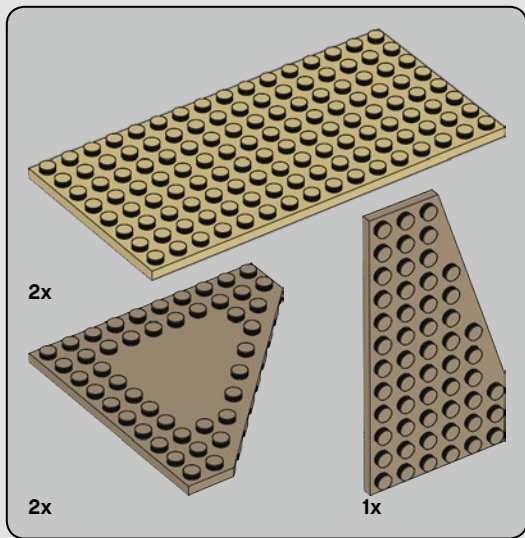

11

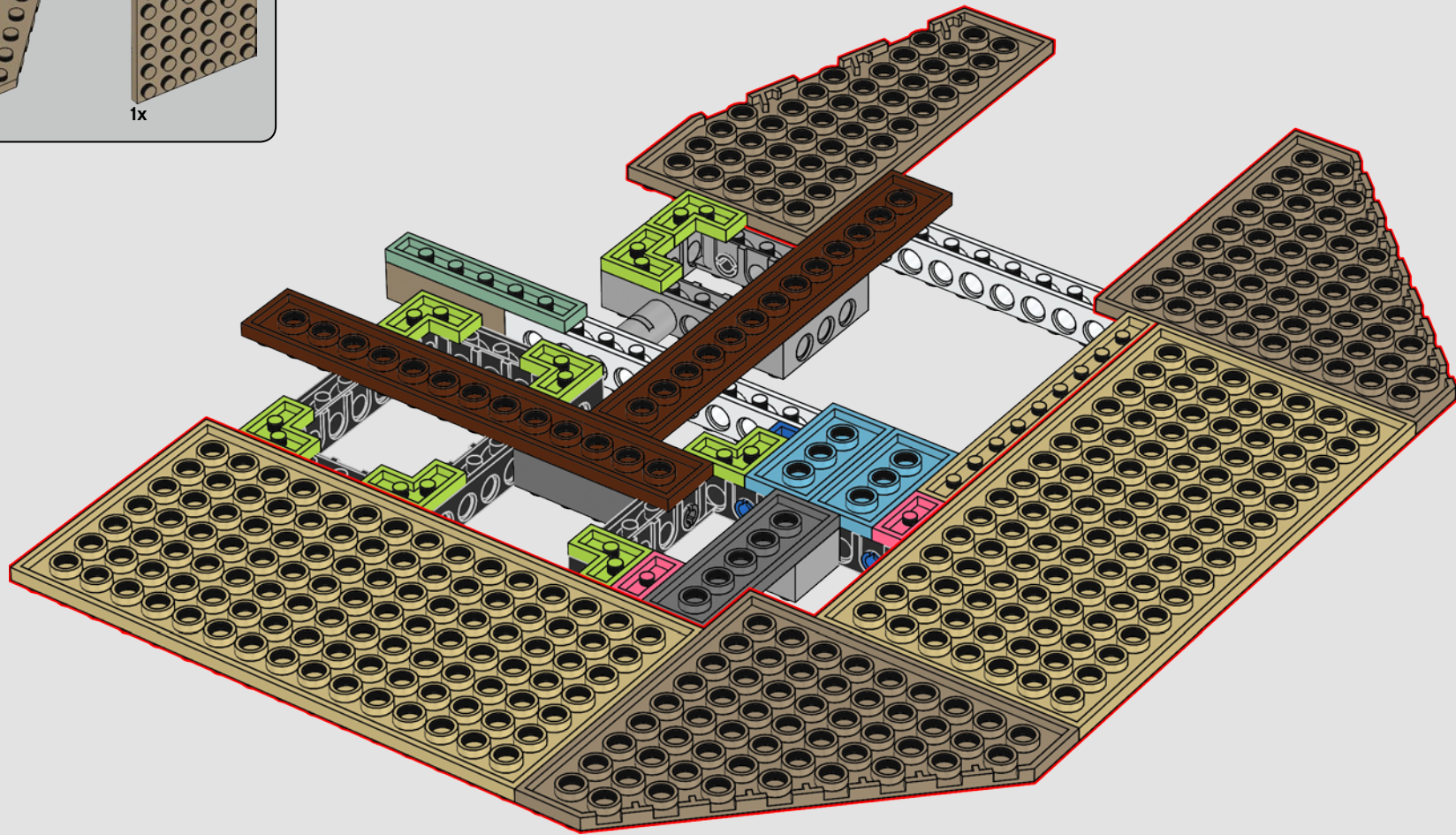

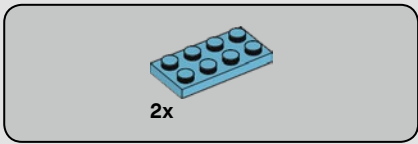

12

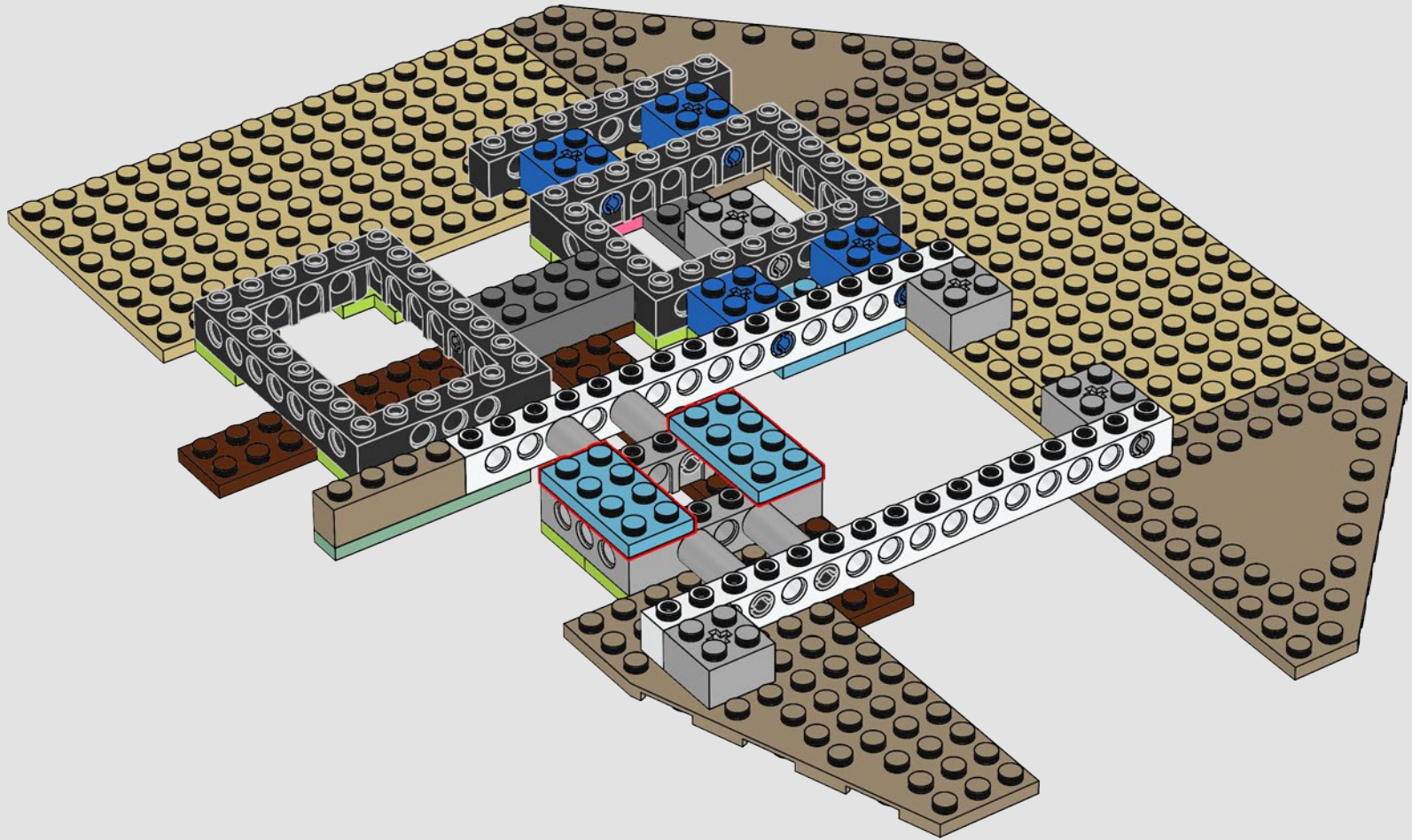
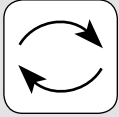

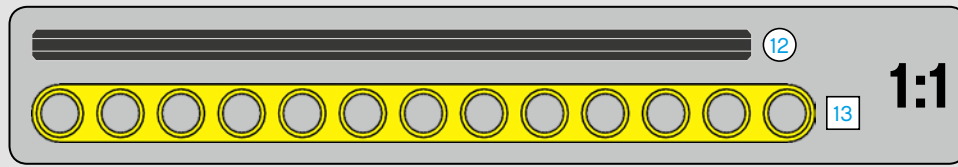
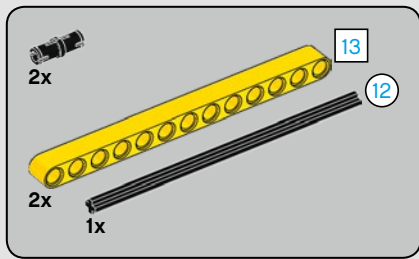

13

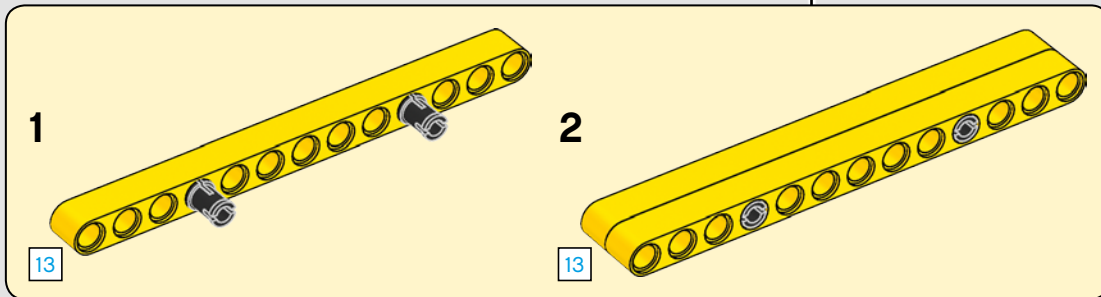
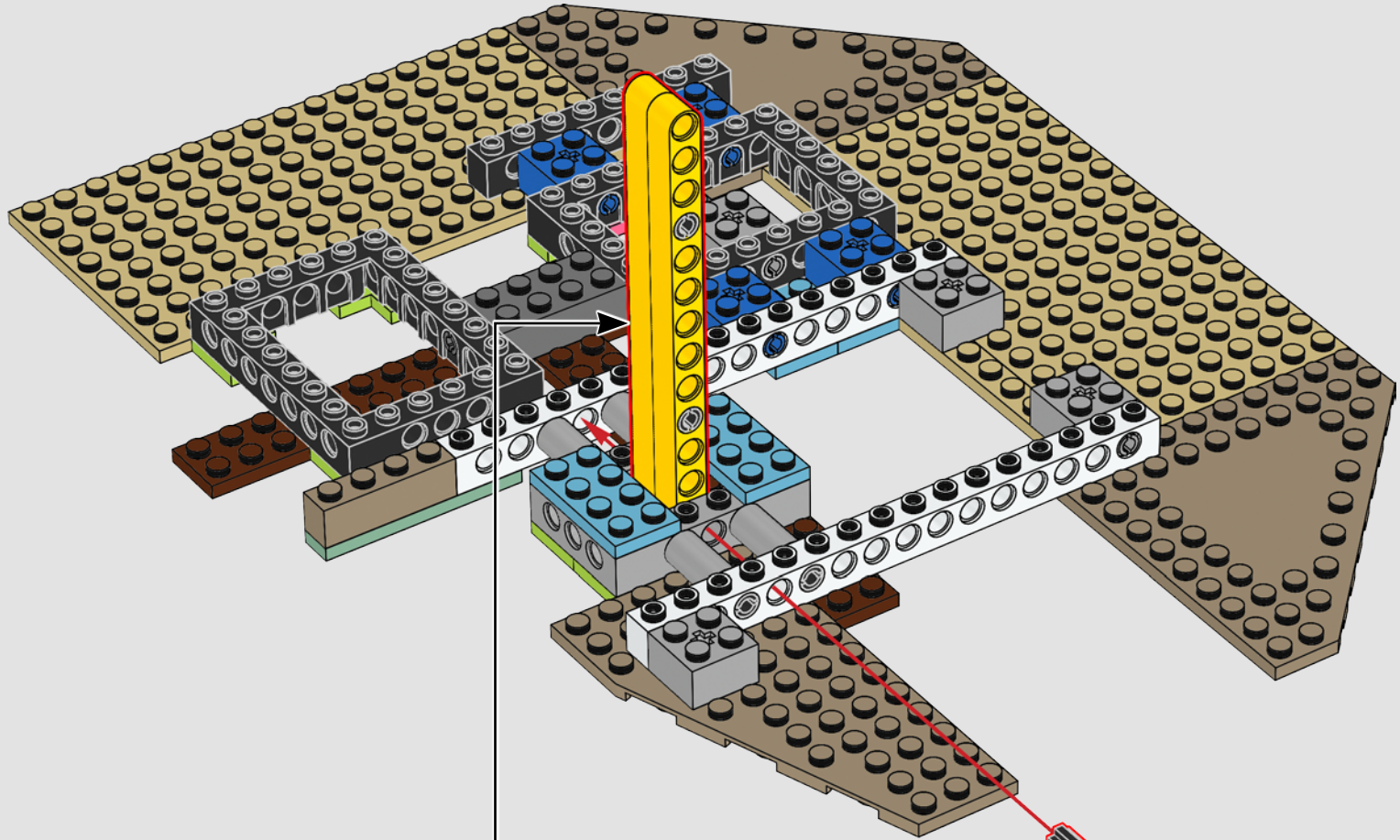



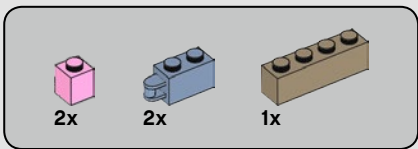

14

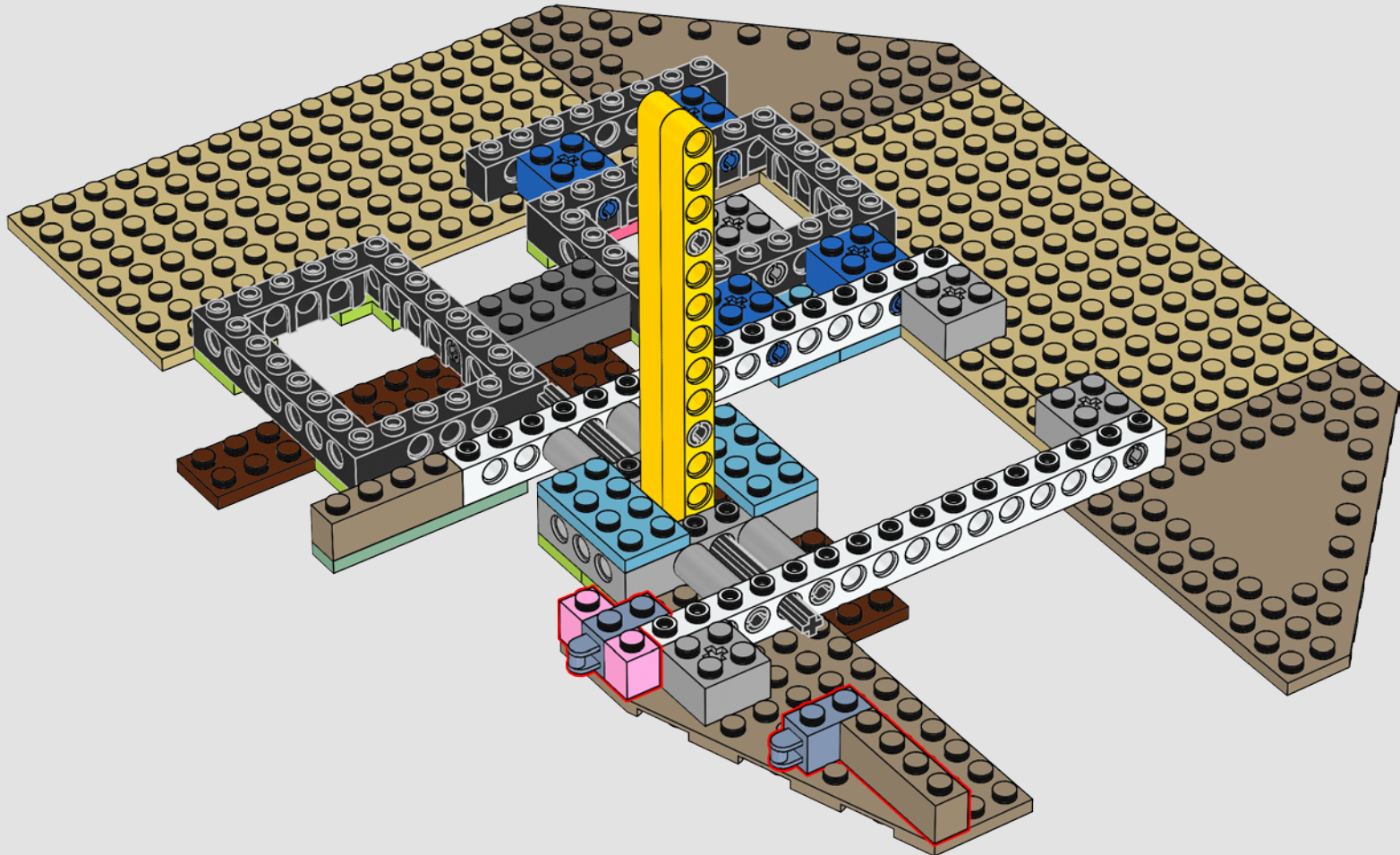

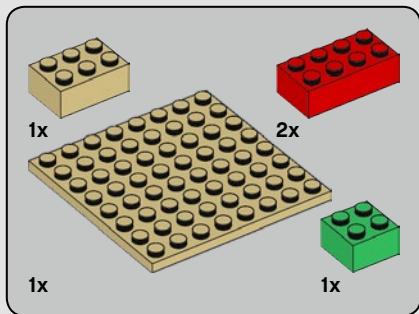

15

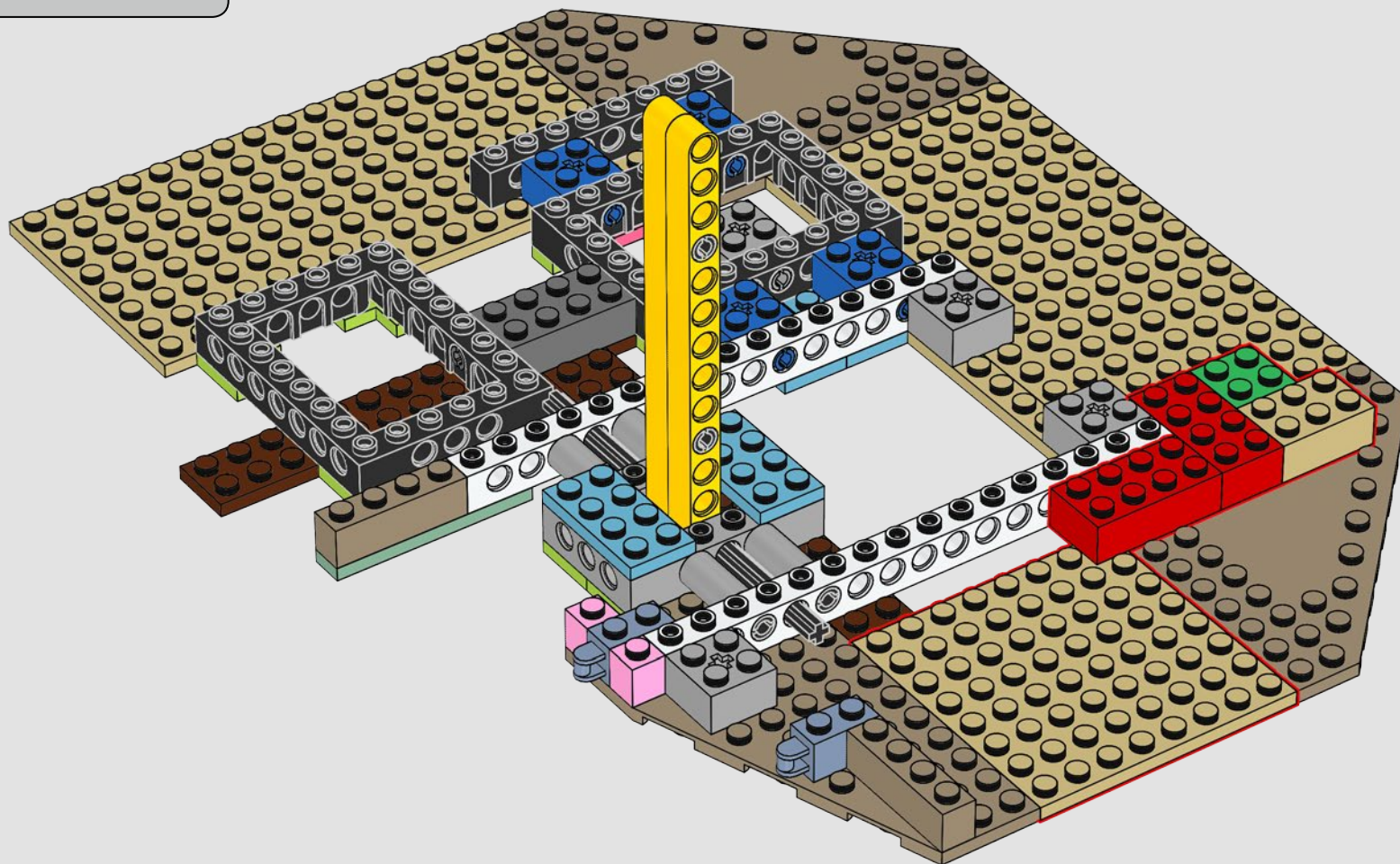

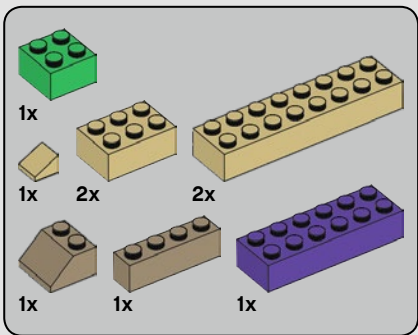

16

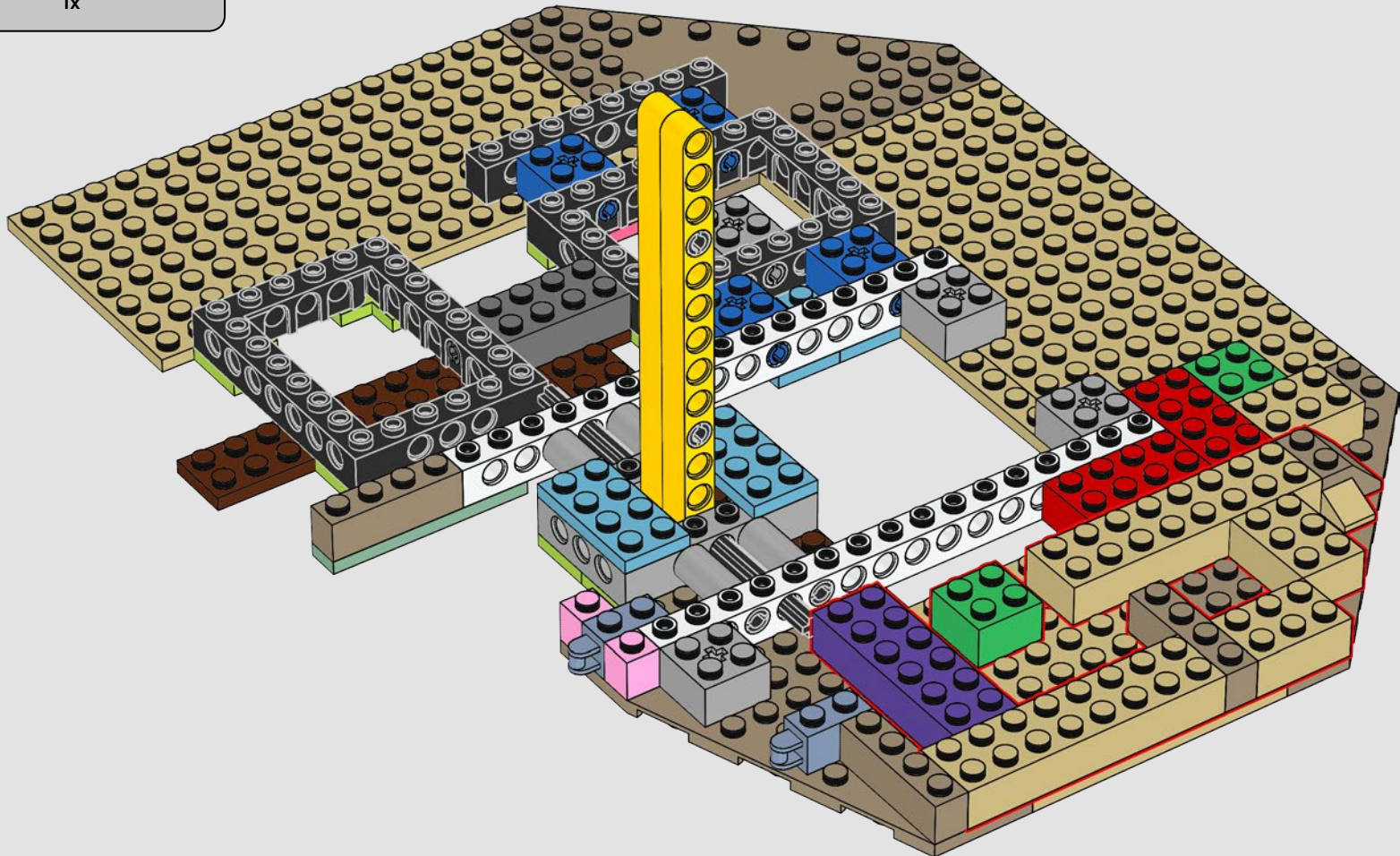

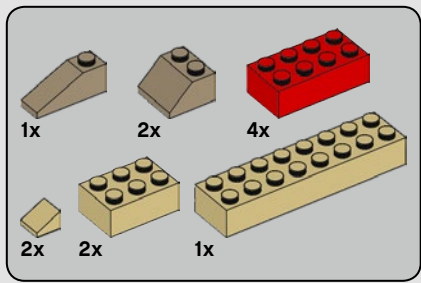

17

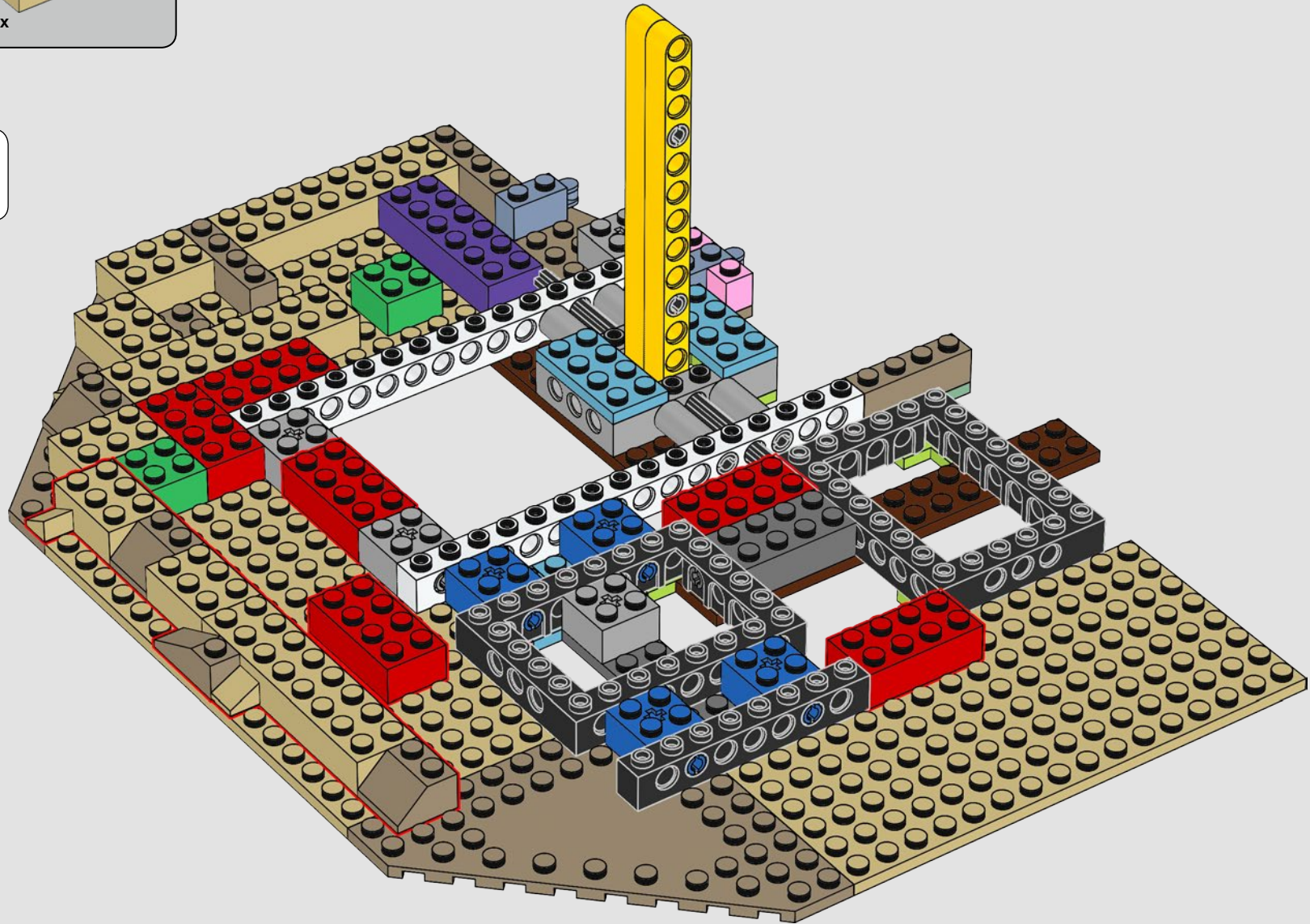
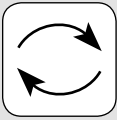

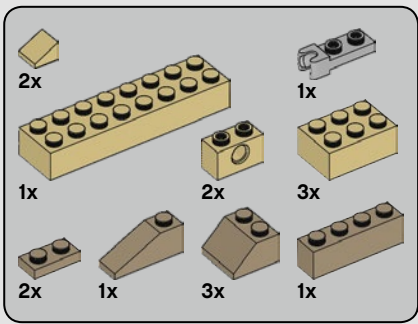

18

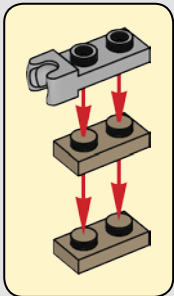
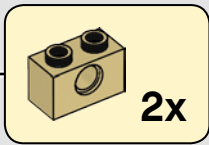
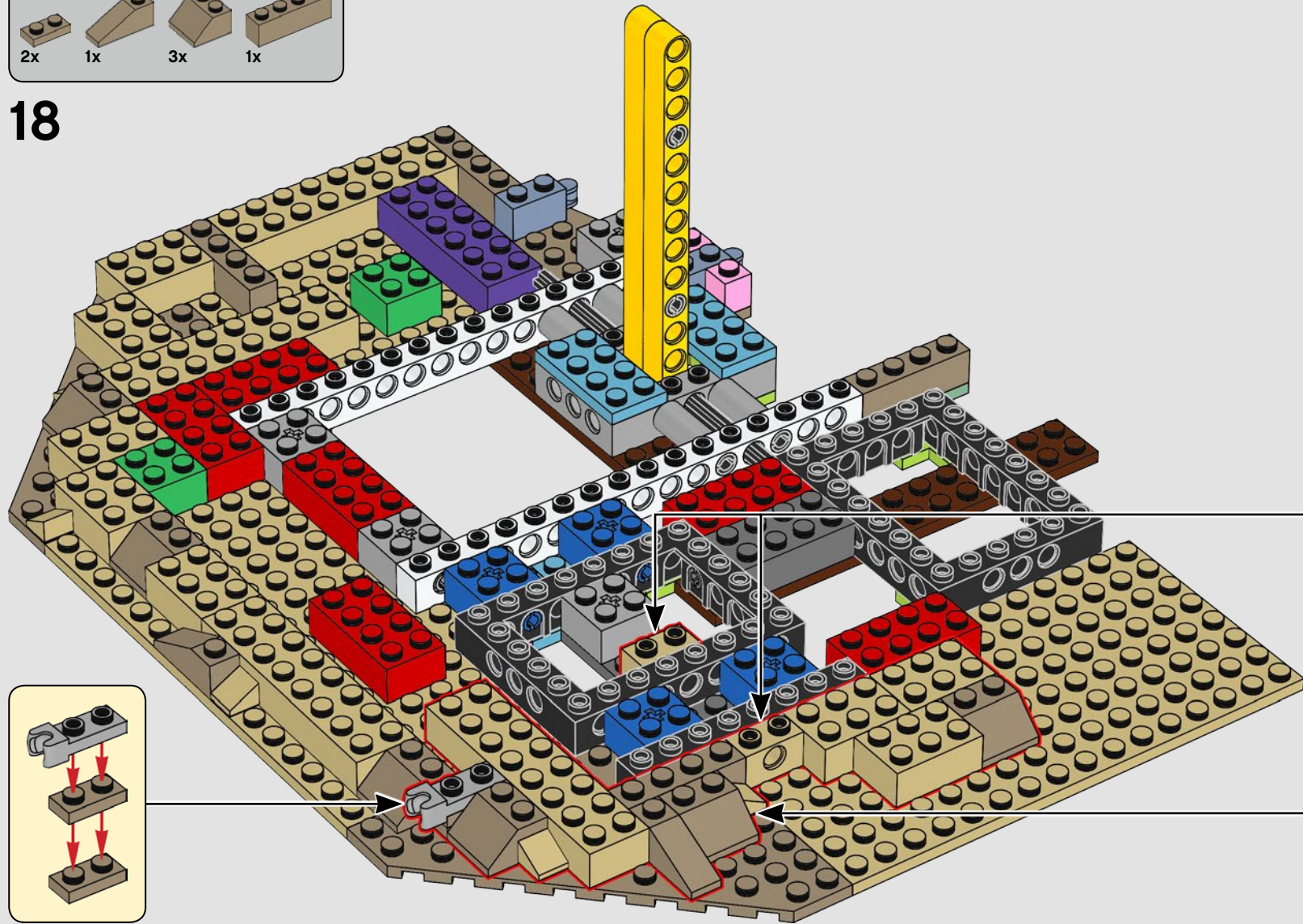

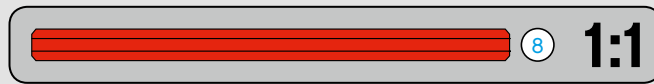
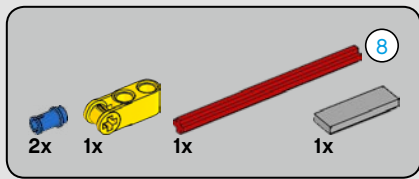

19

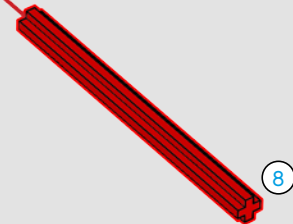
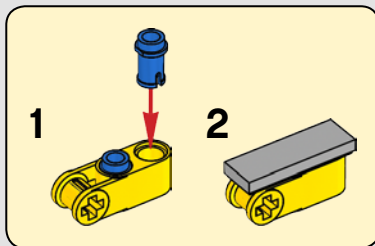
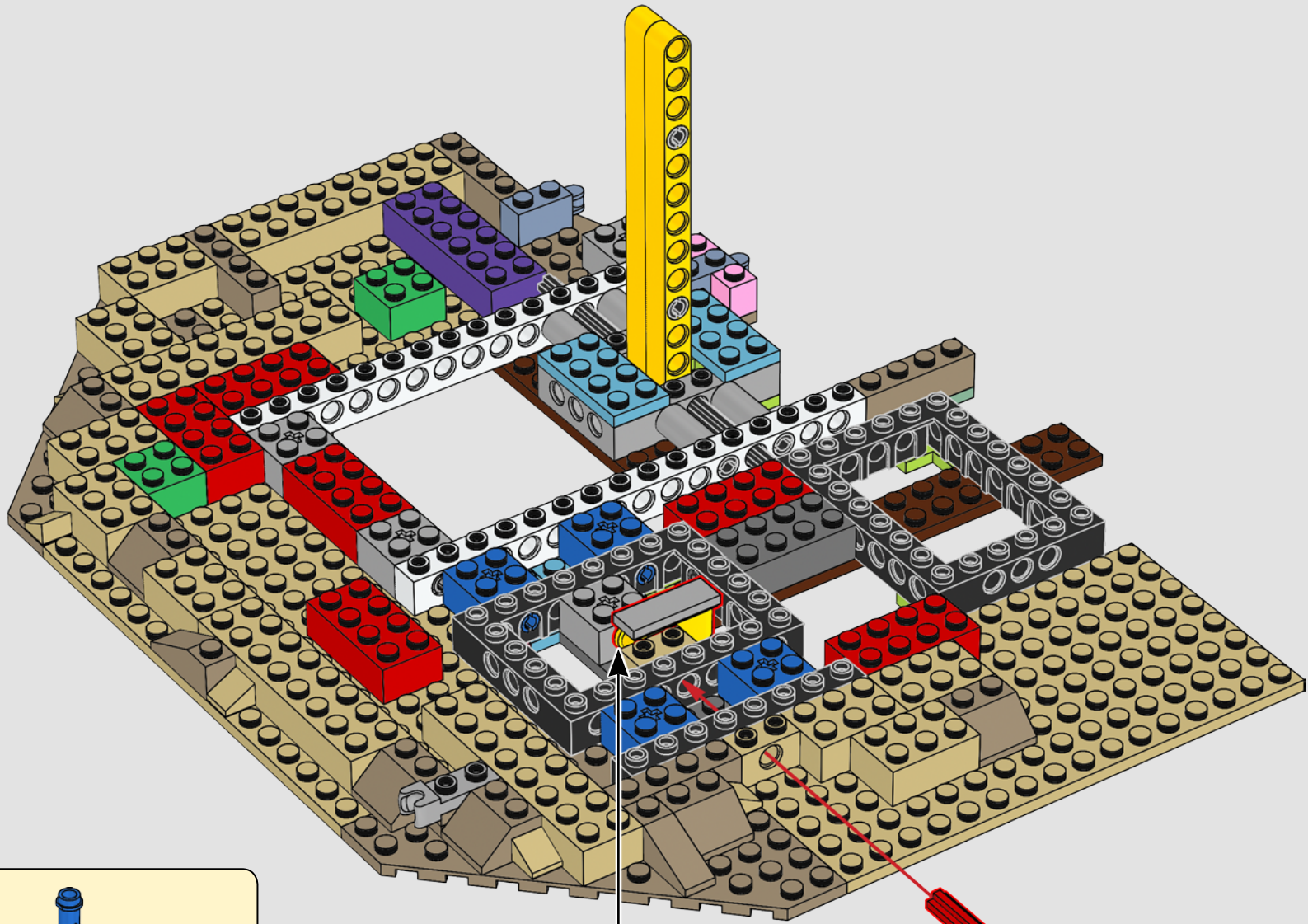

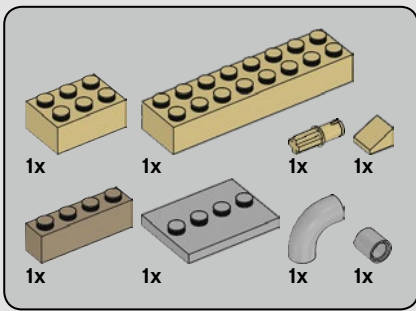

20

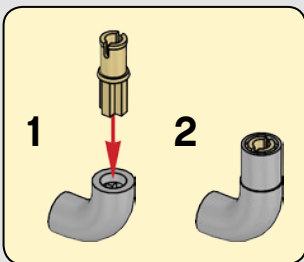
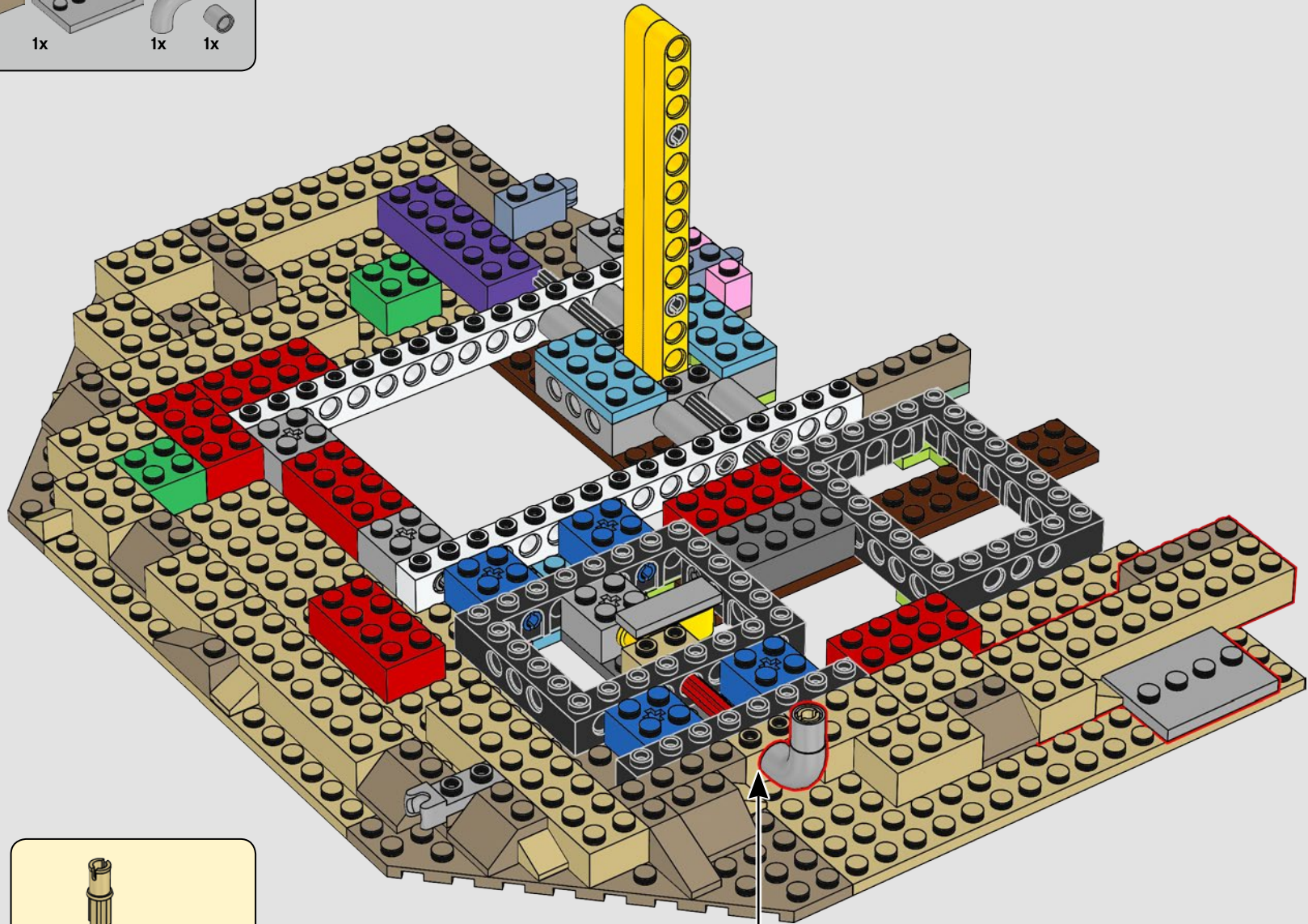

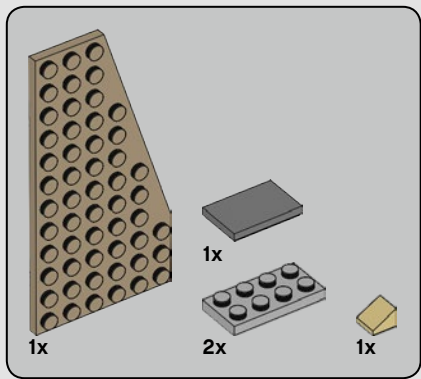

21

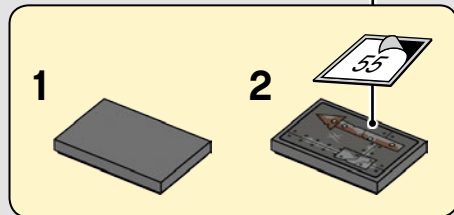
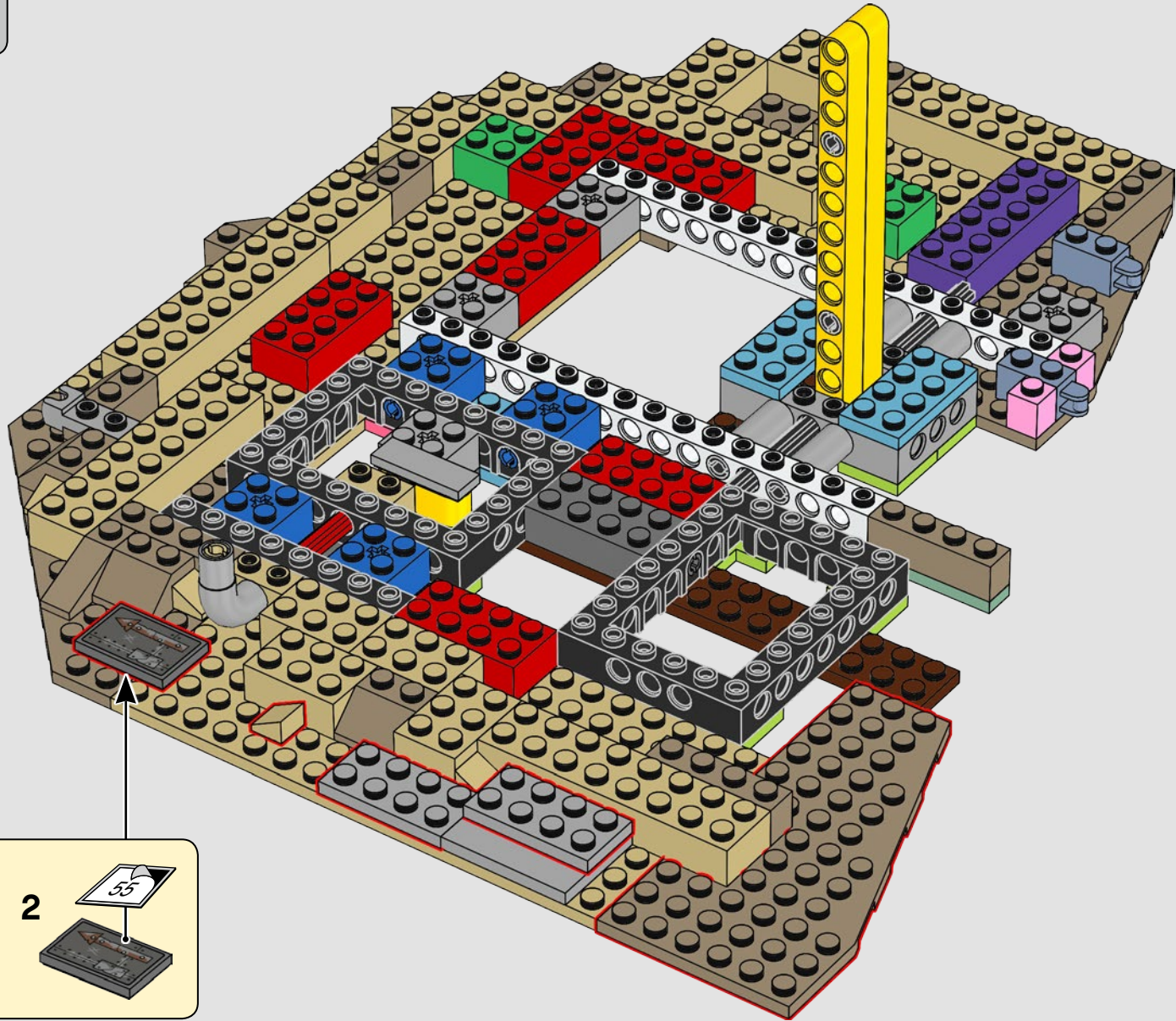



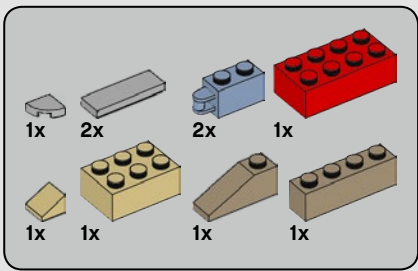

22

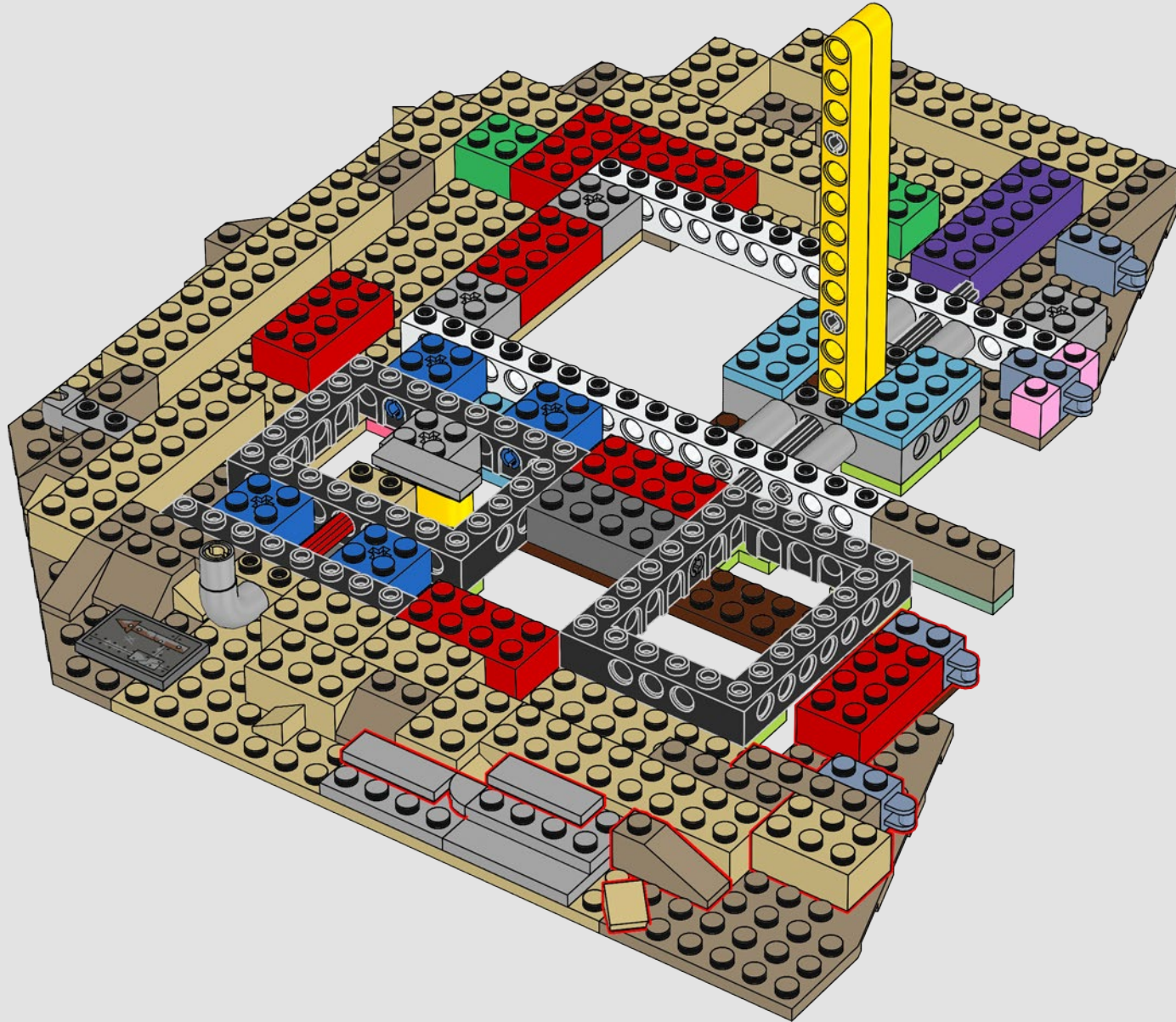

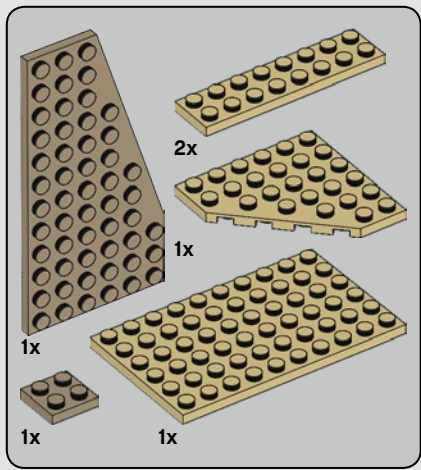

23

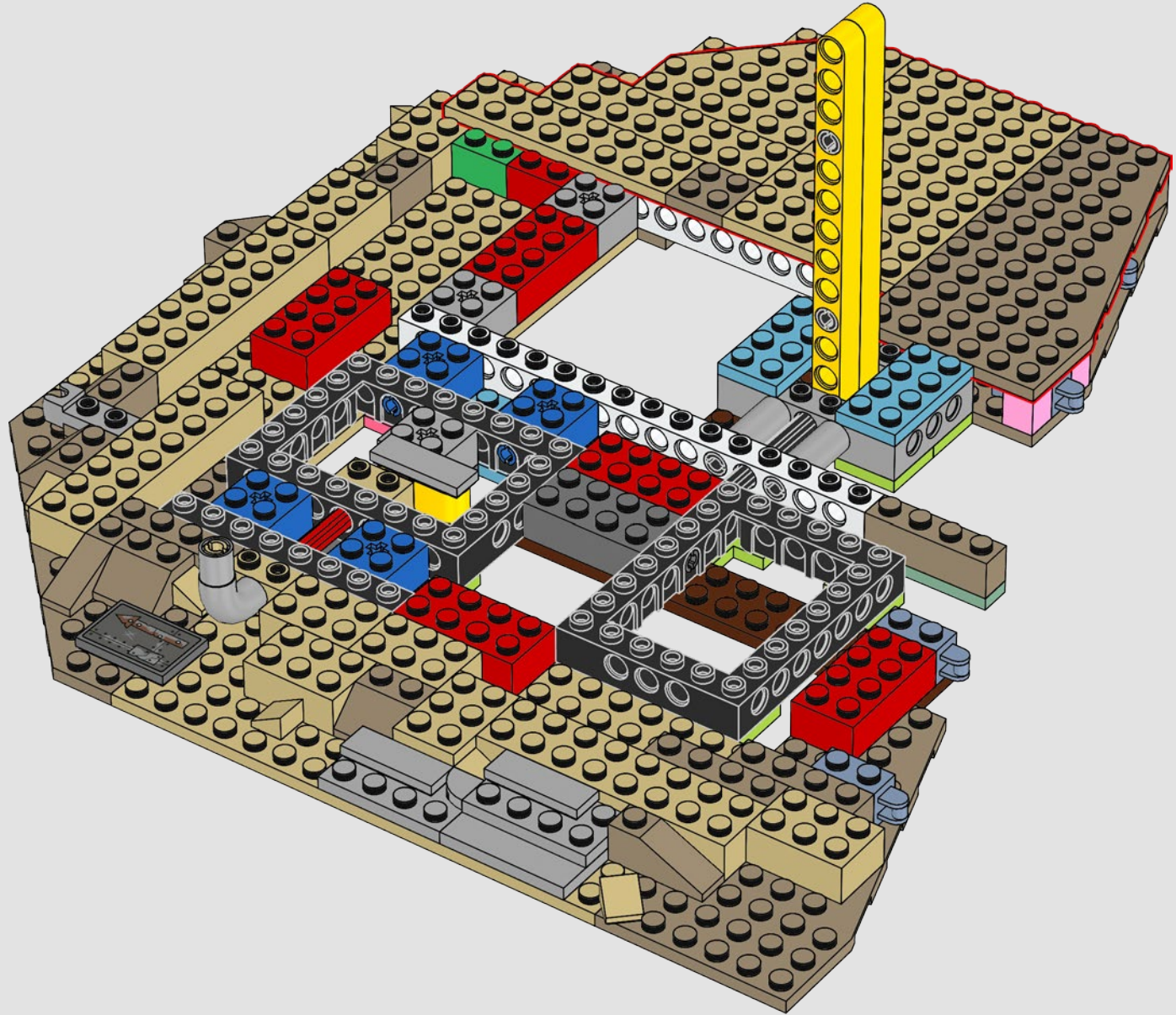

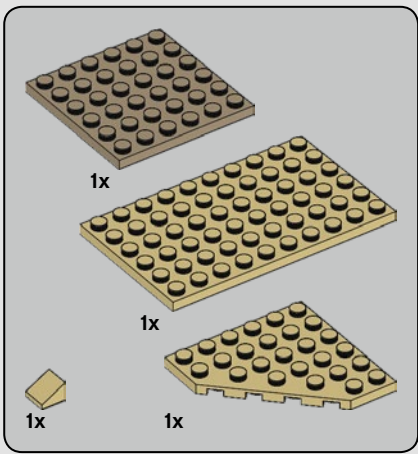

24

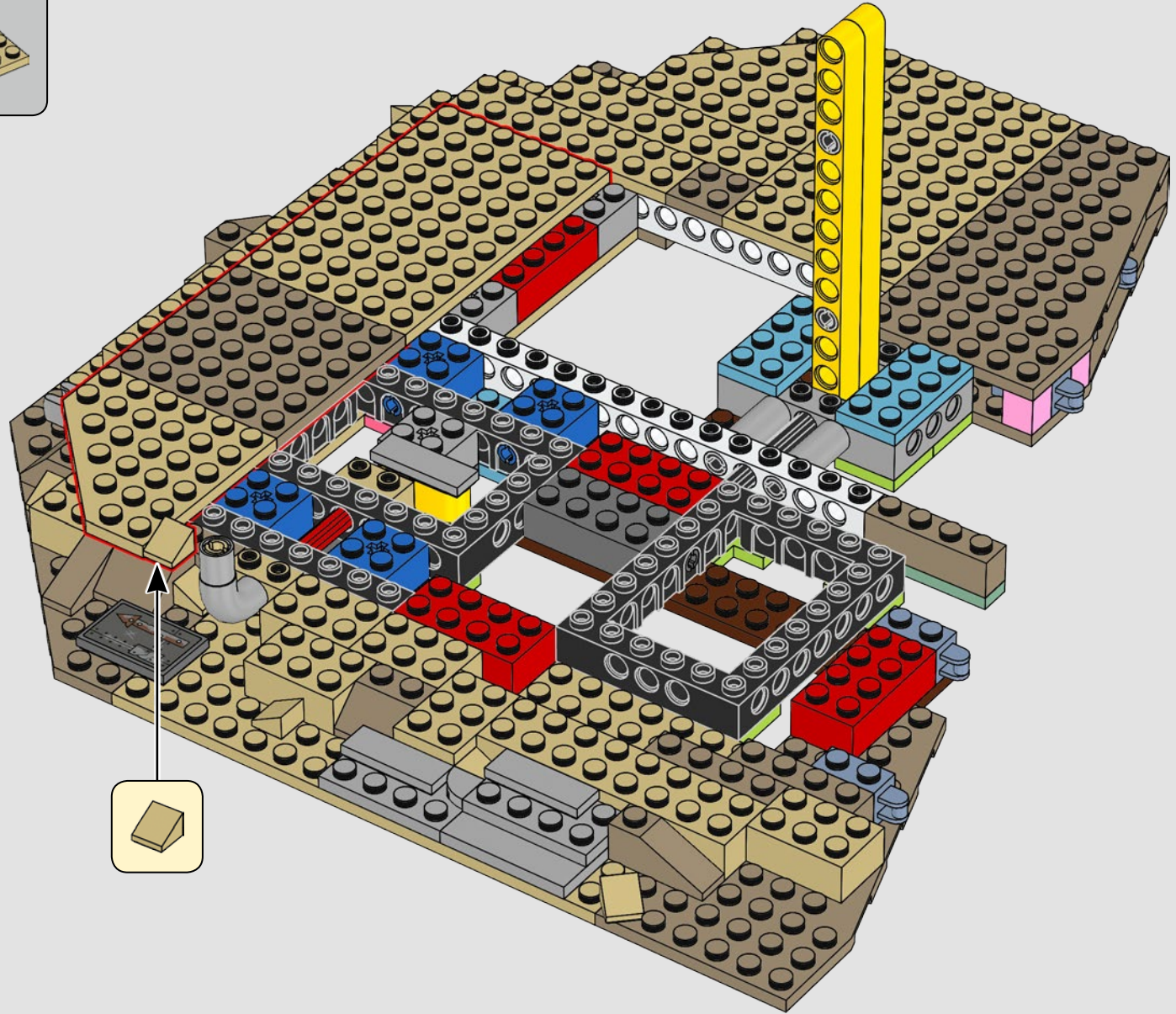

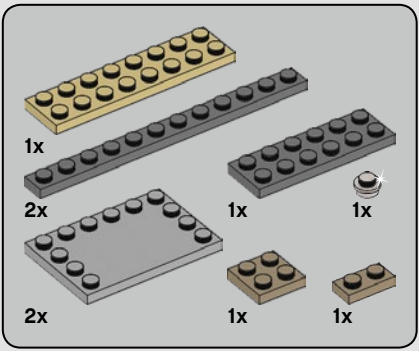

25

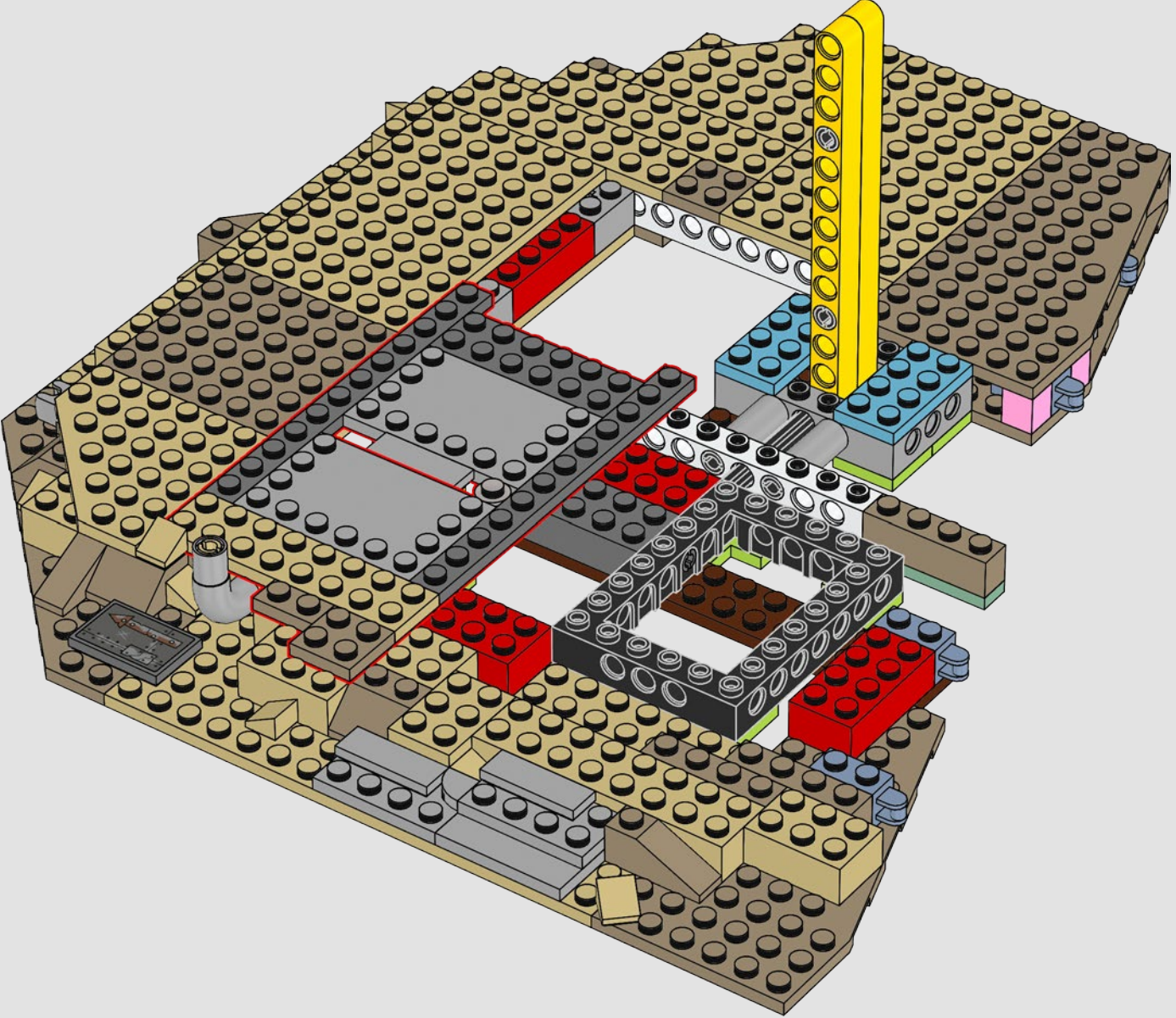

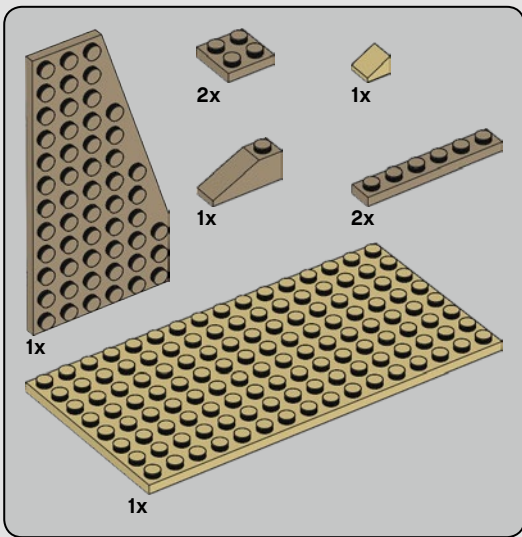

26

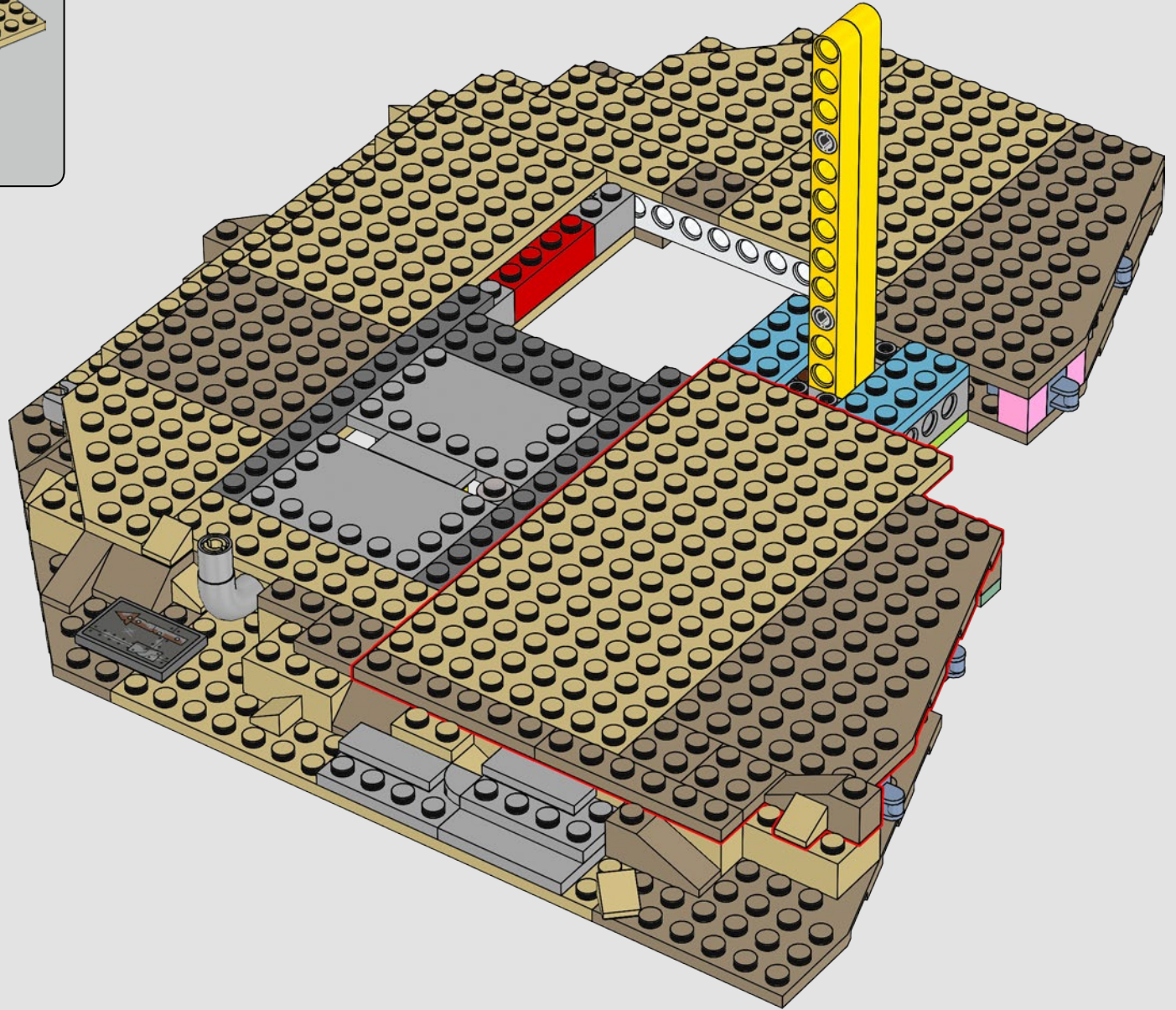

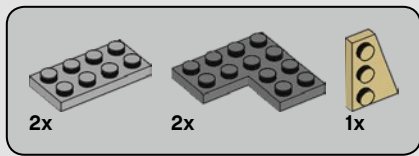

27

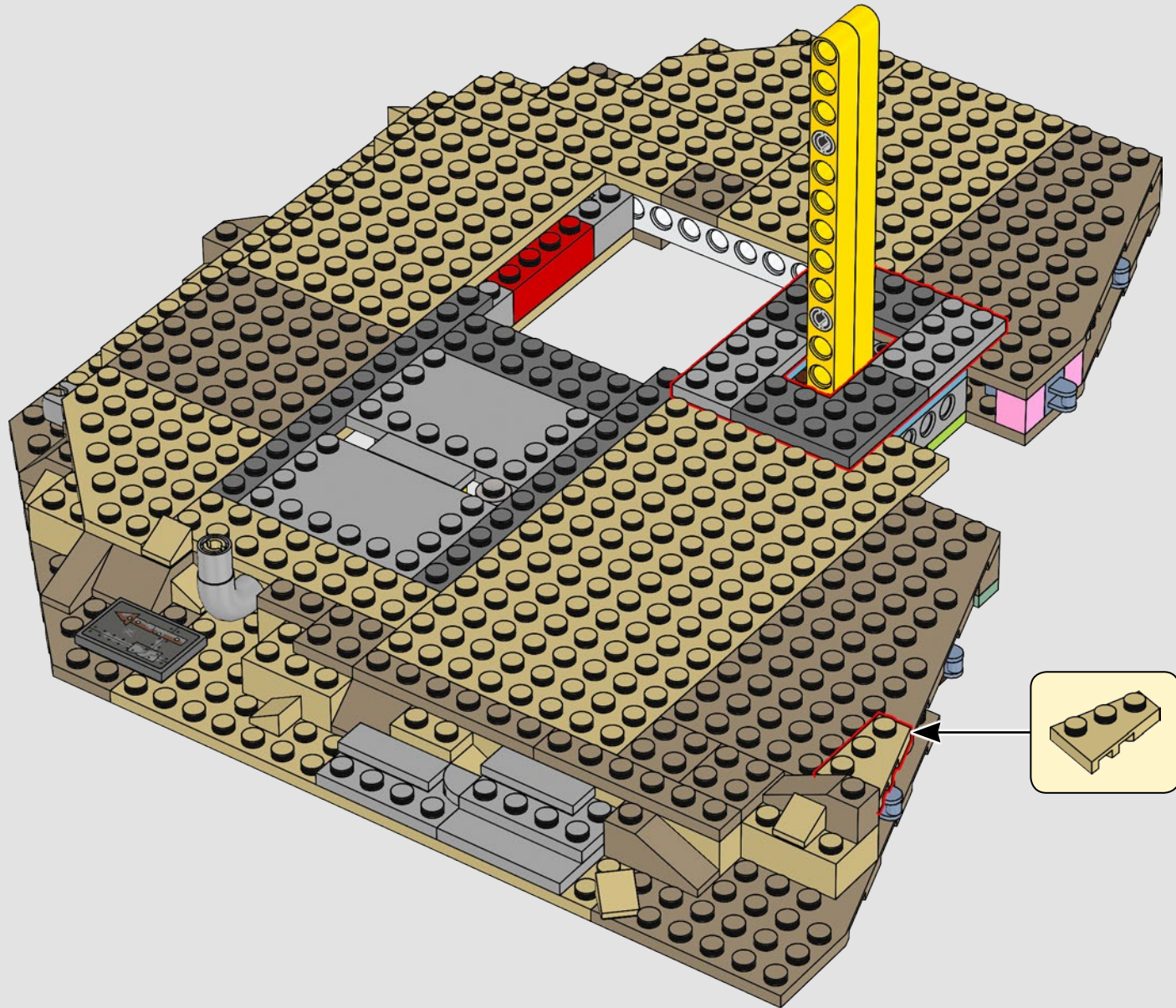

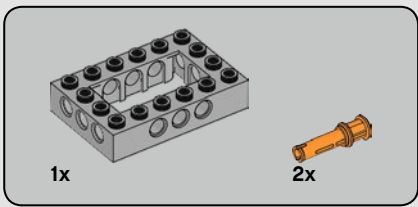

28

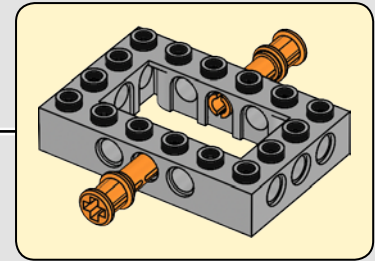
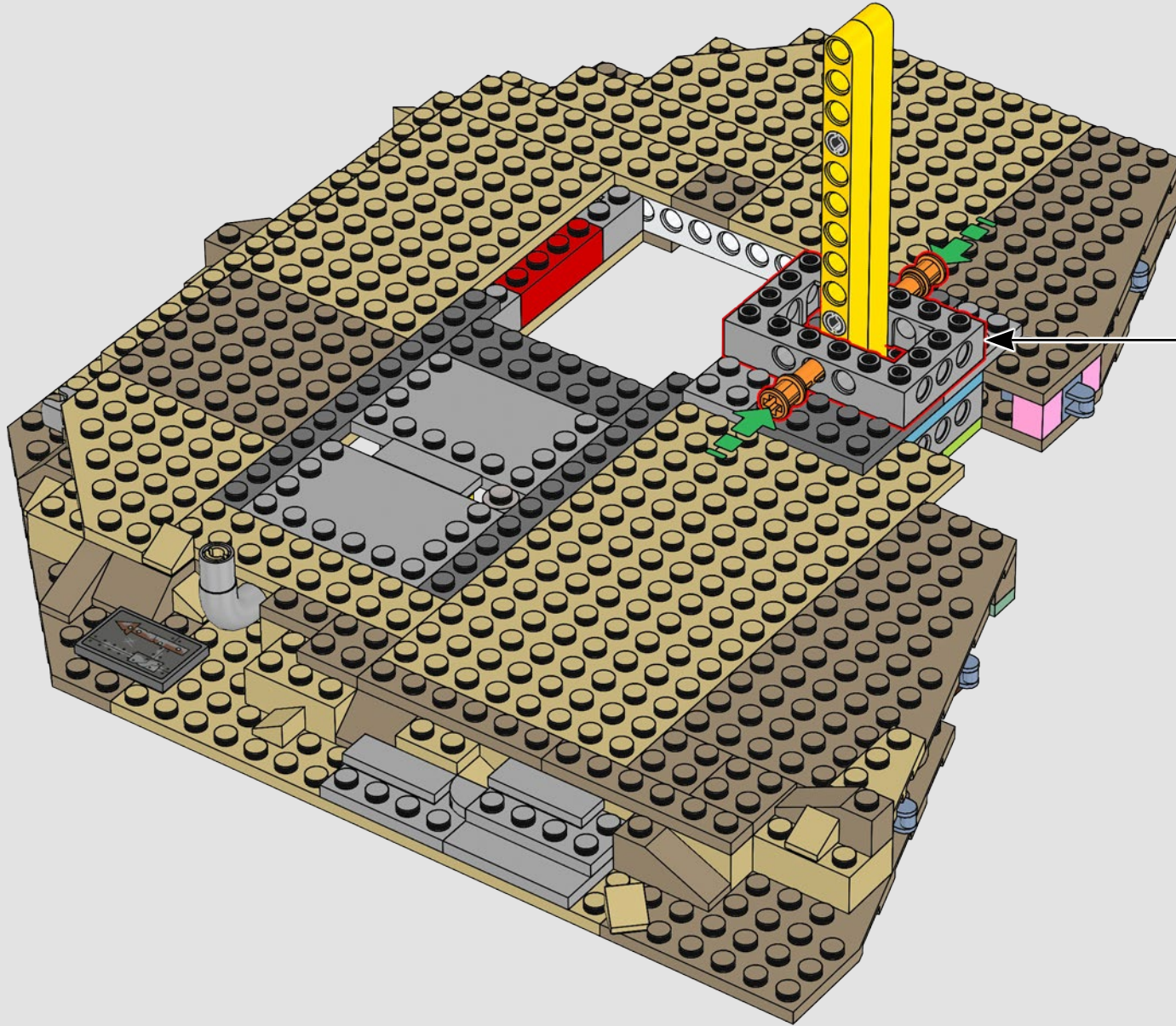



4x

29

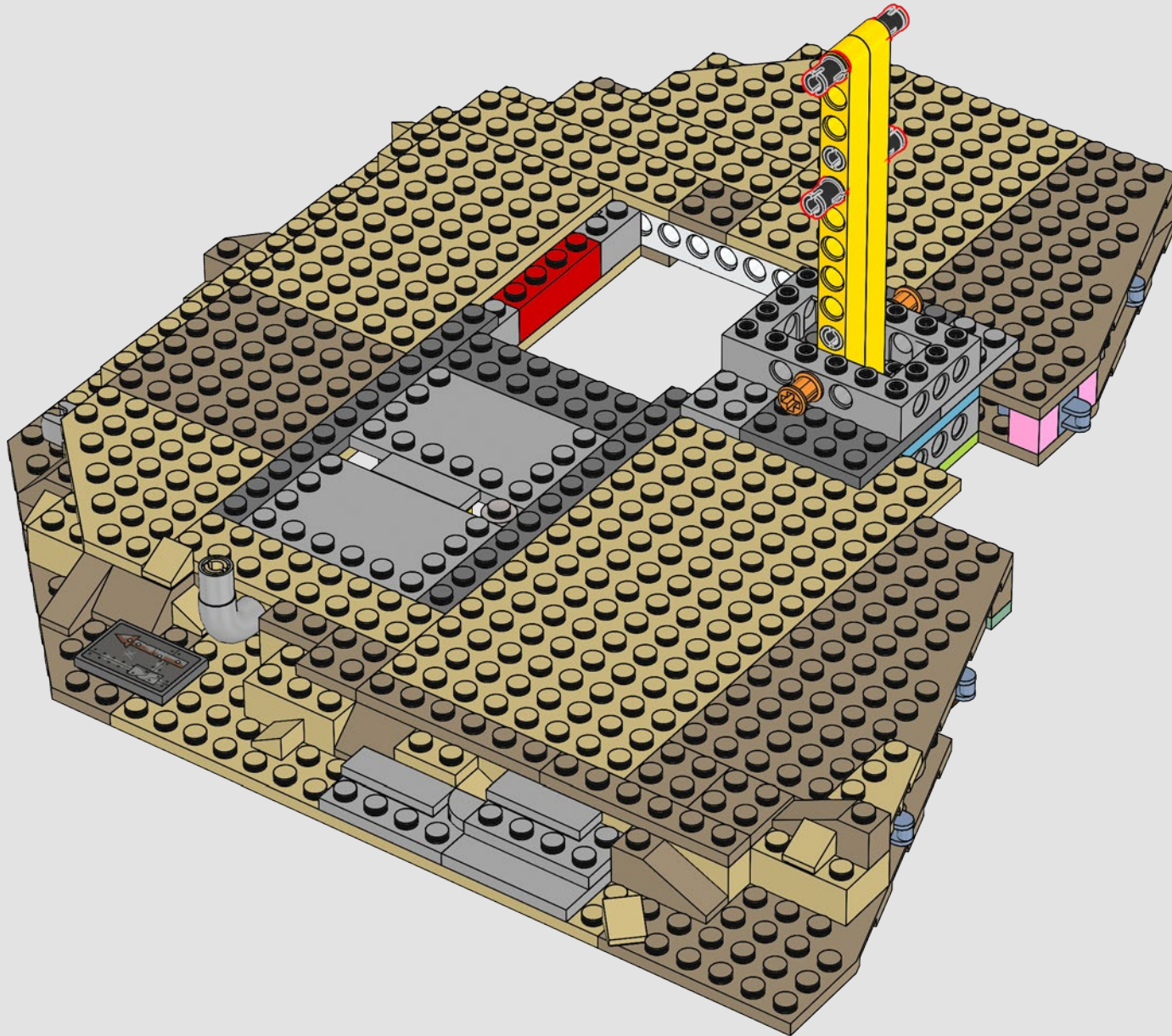



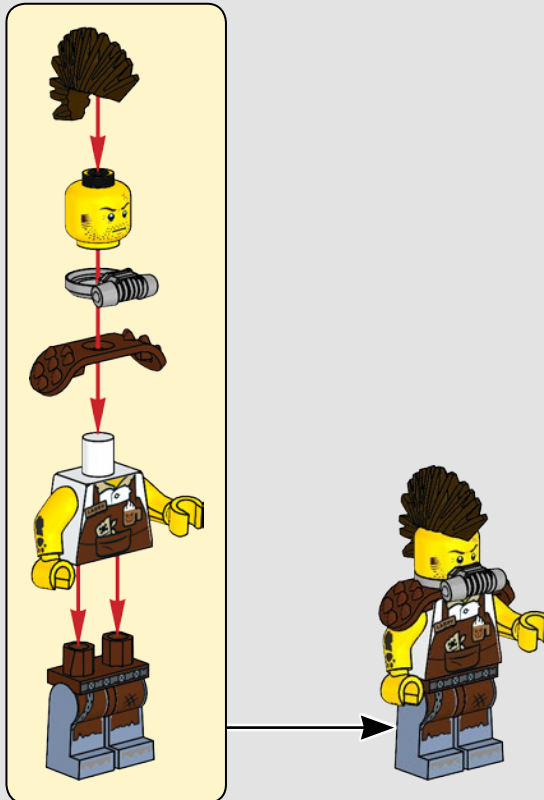
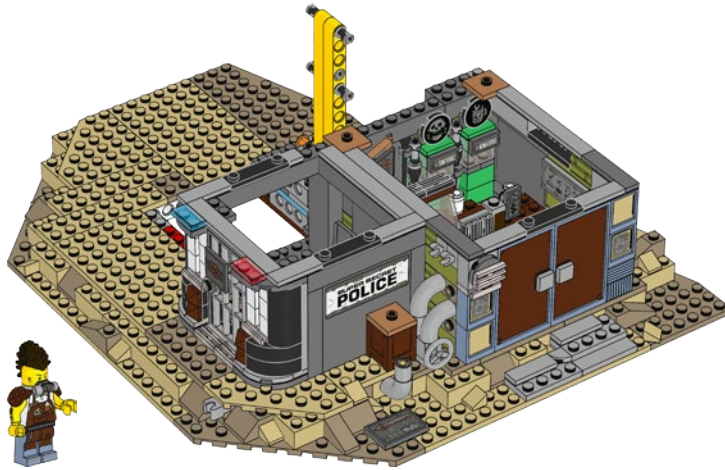

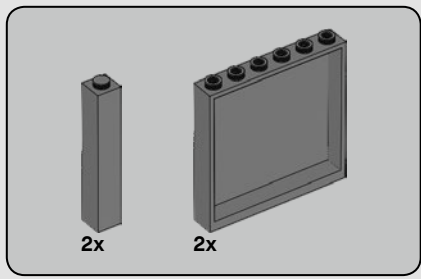

30

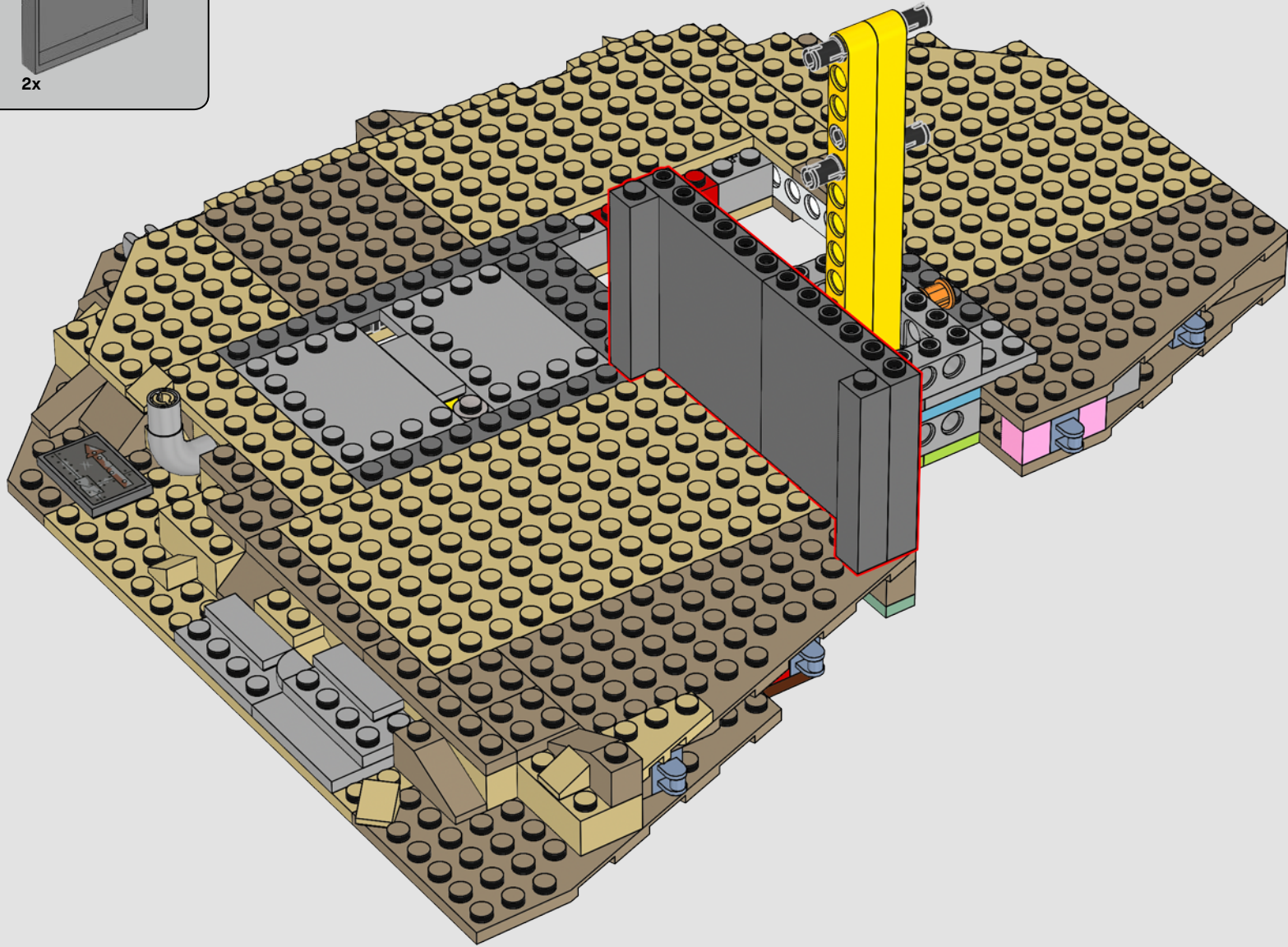

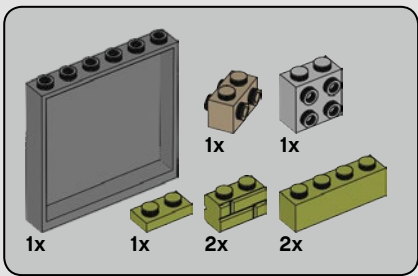

31

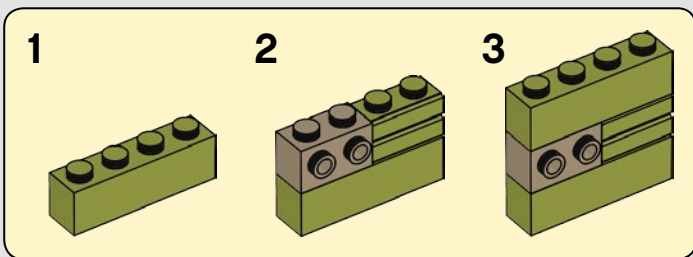
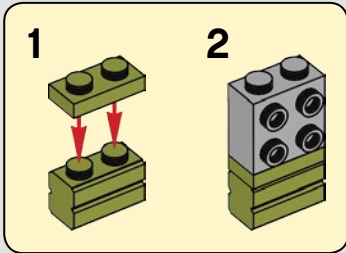
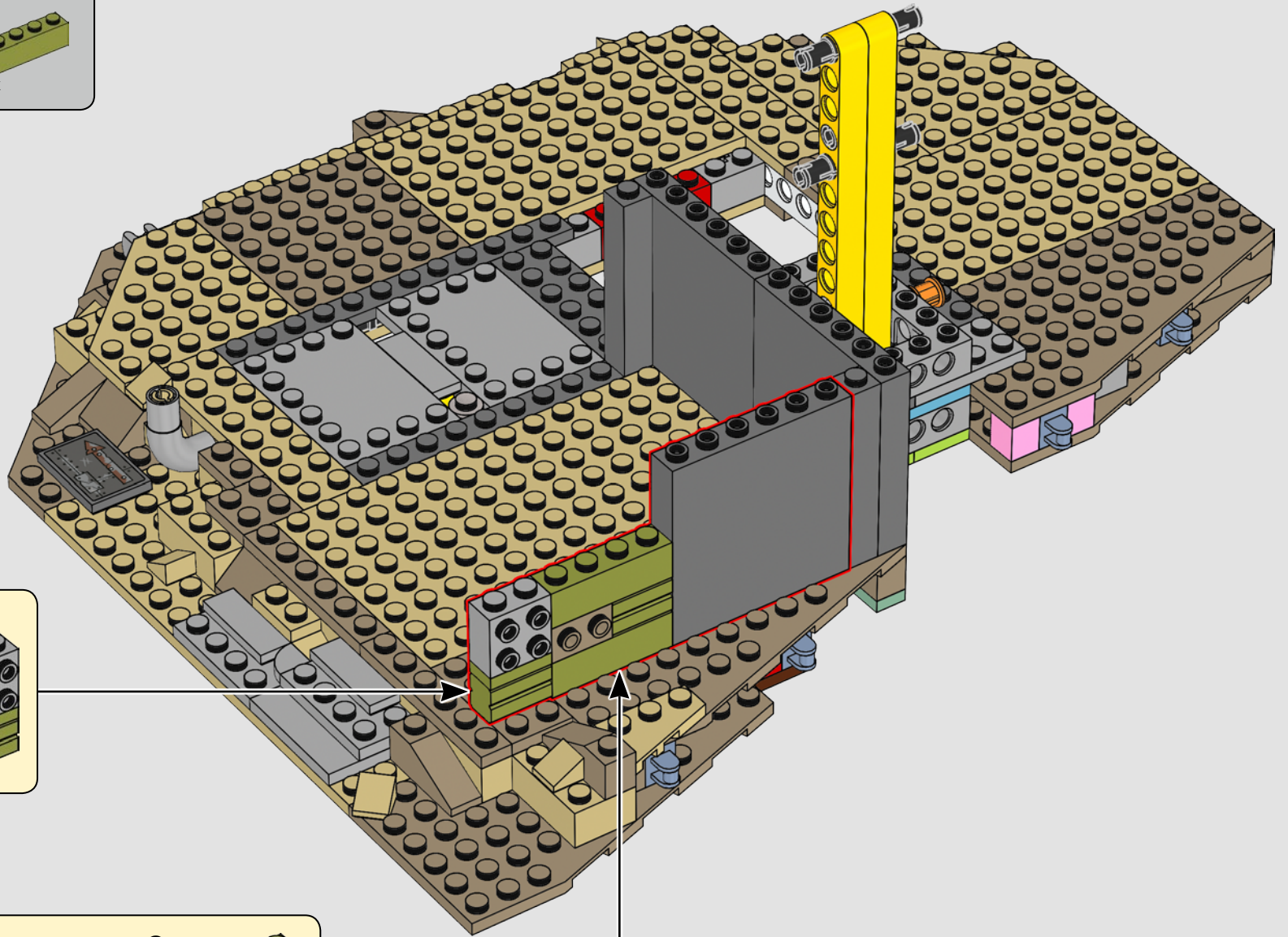

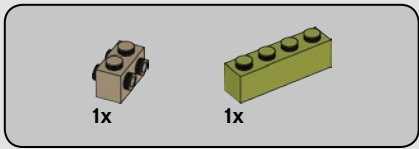

32

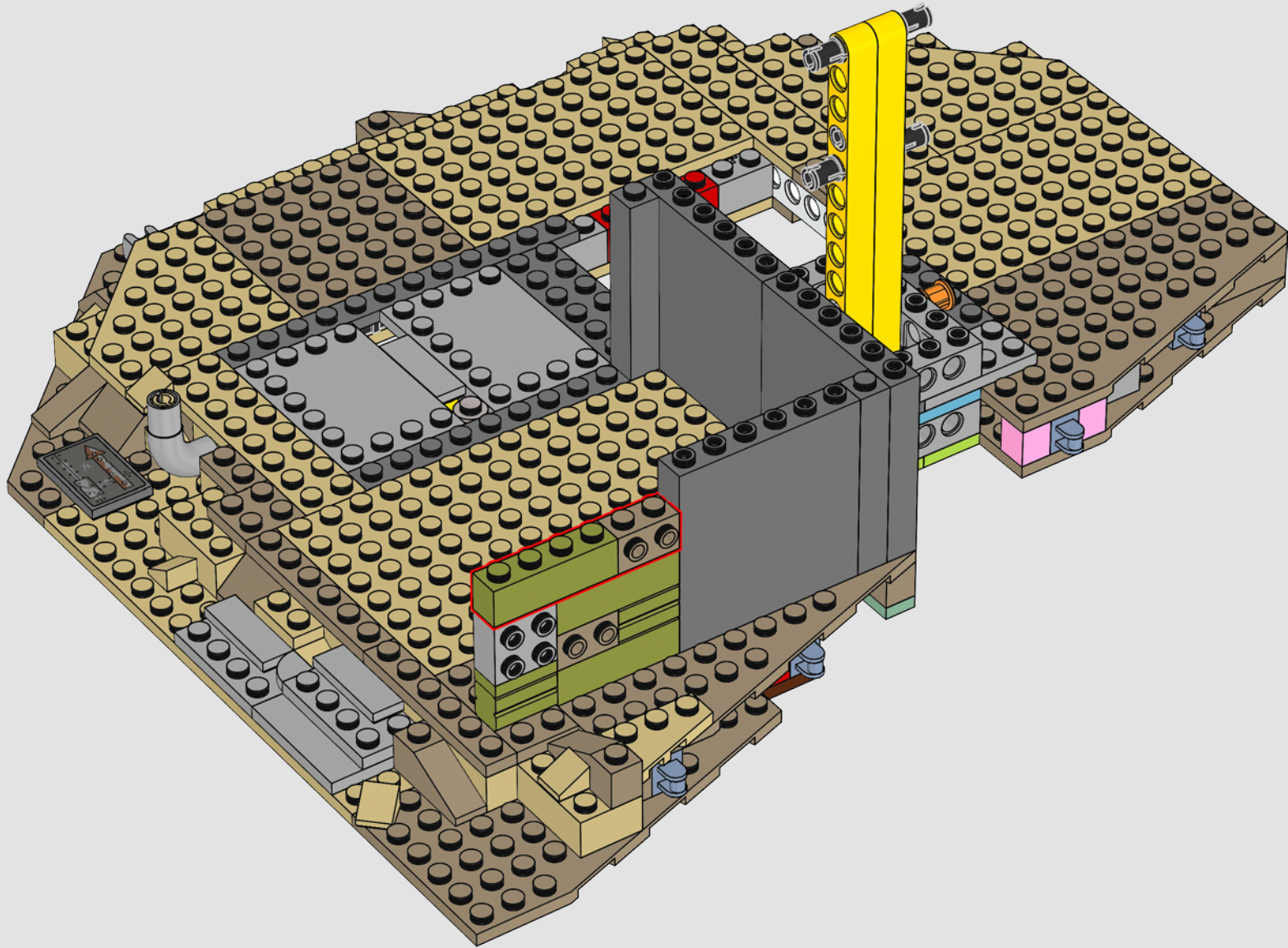

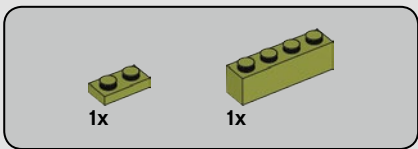

33

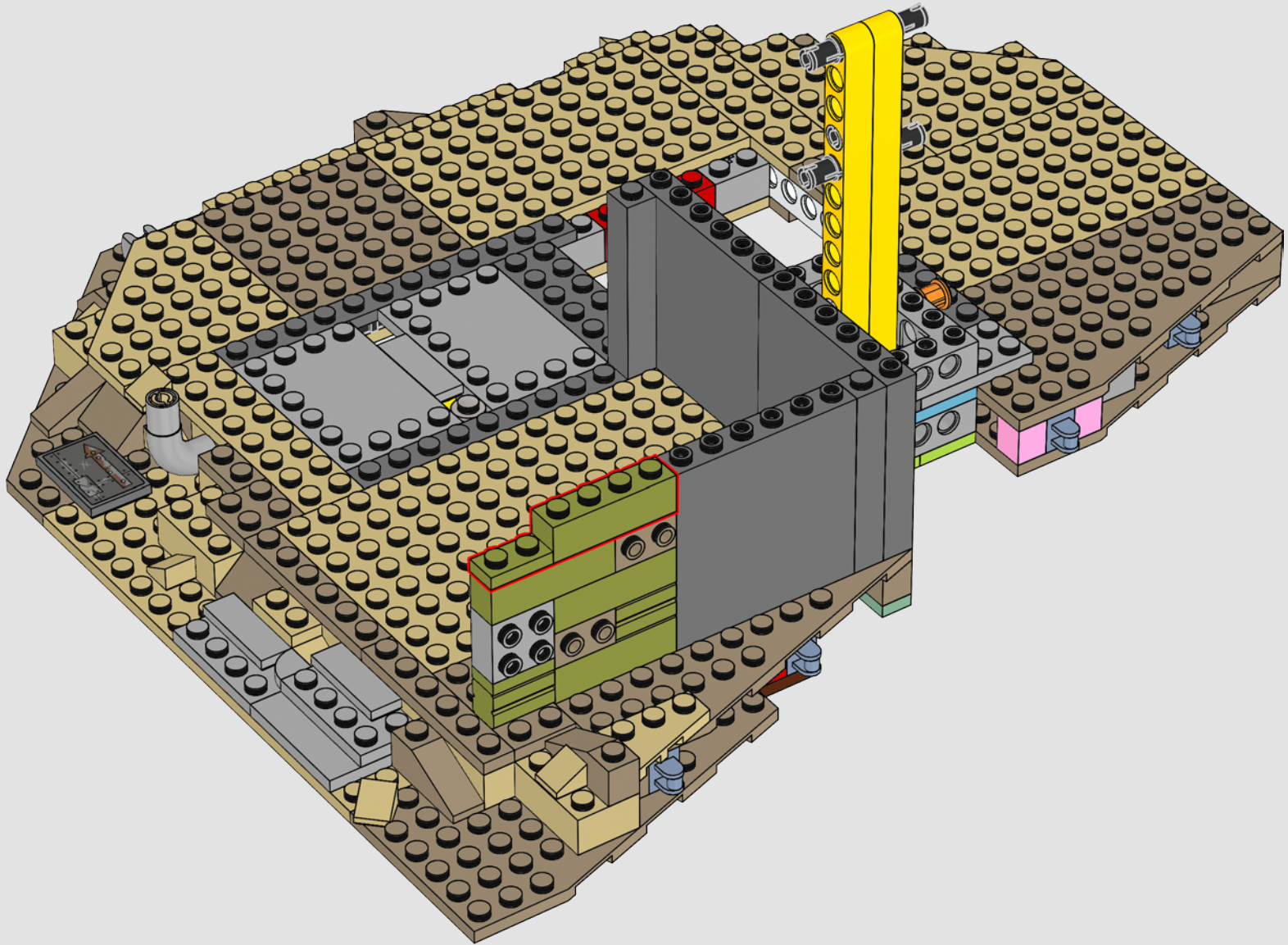

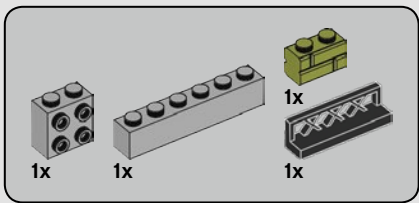

34

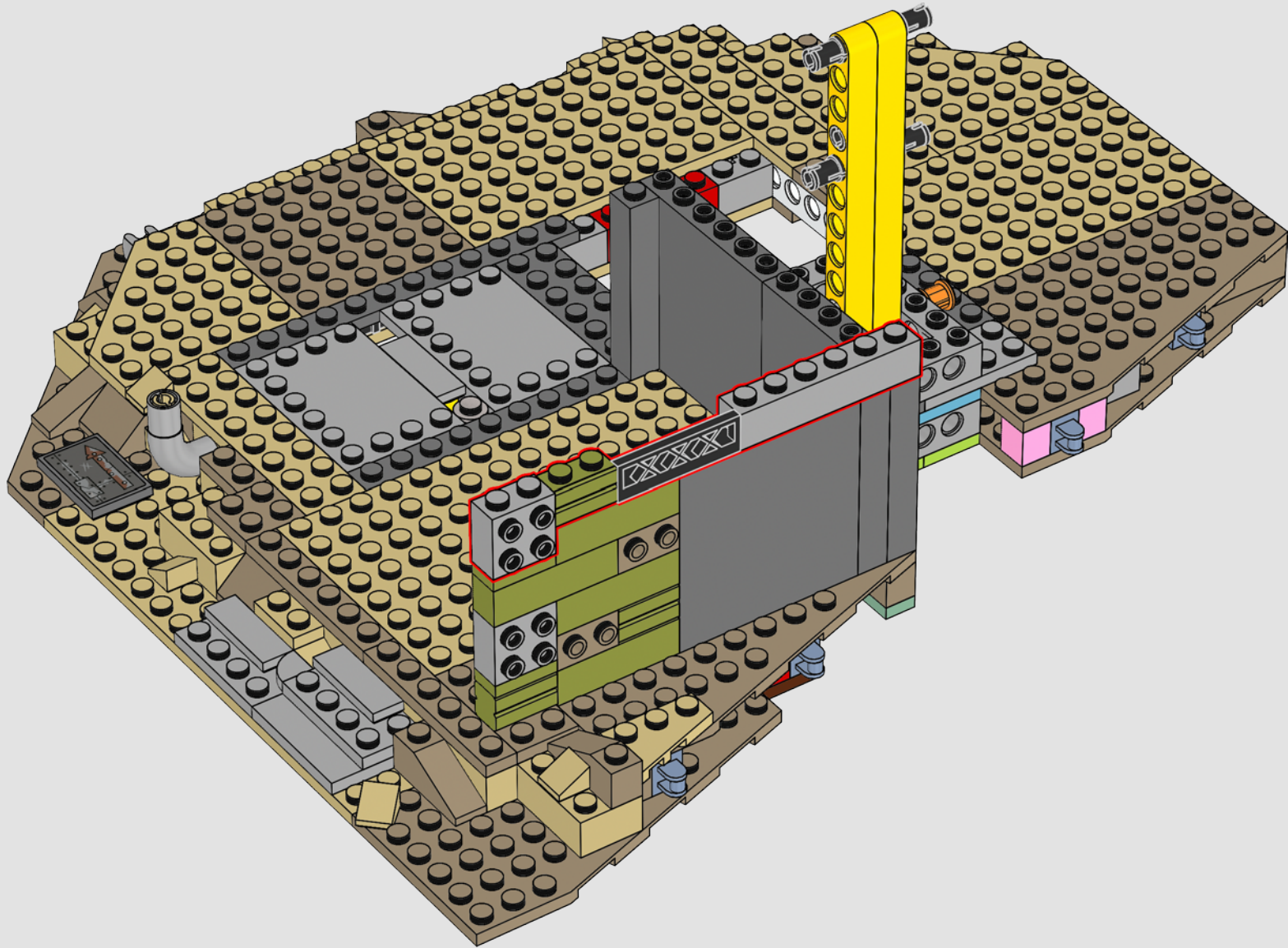

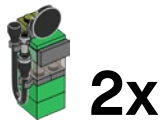

2x



2x

35

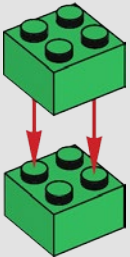

1x



1x

36

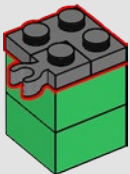

1x



1x

37

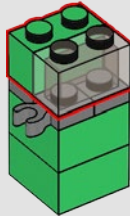

1x

38

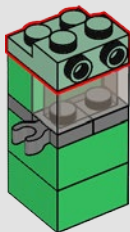

1x



1x

39

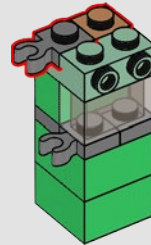

1x



1x

40

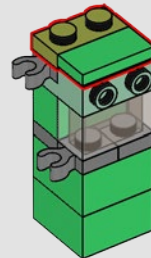

1x



1x

41

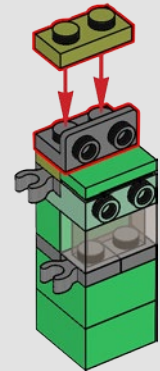

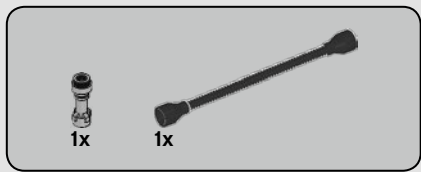

42

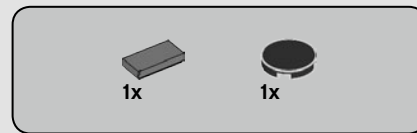
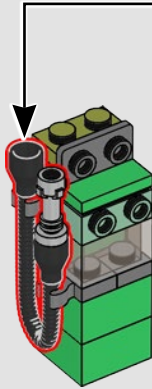

43

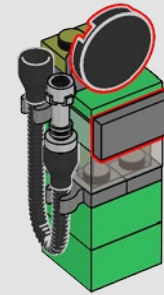

2x

44

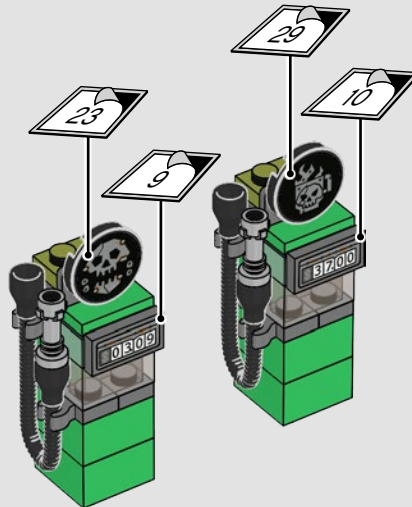



45

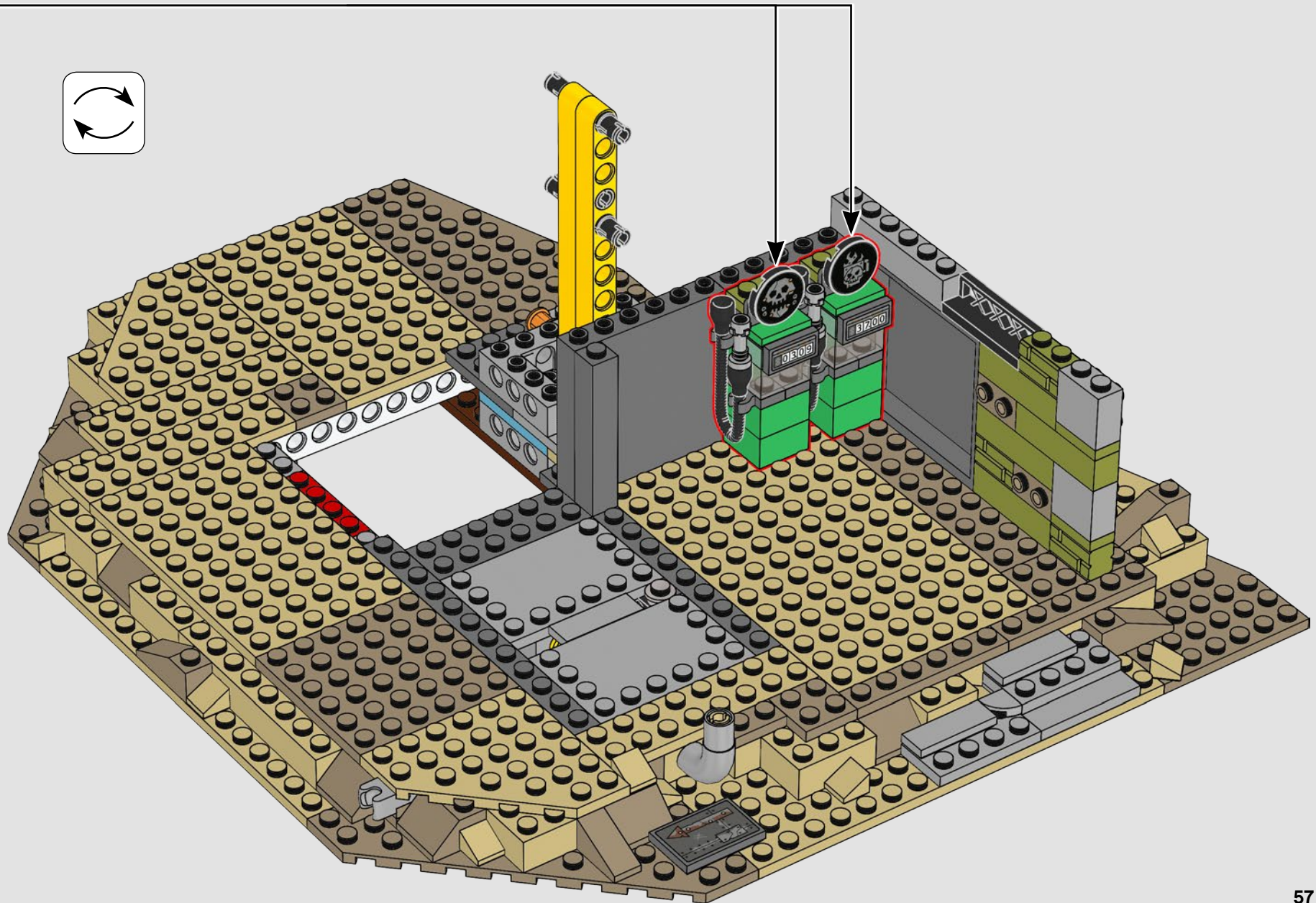
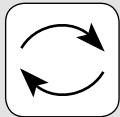

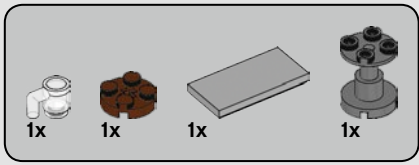

46

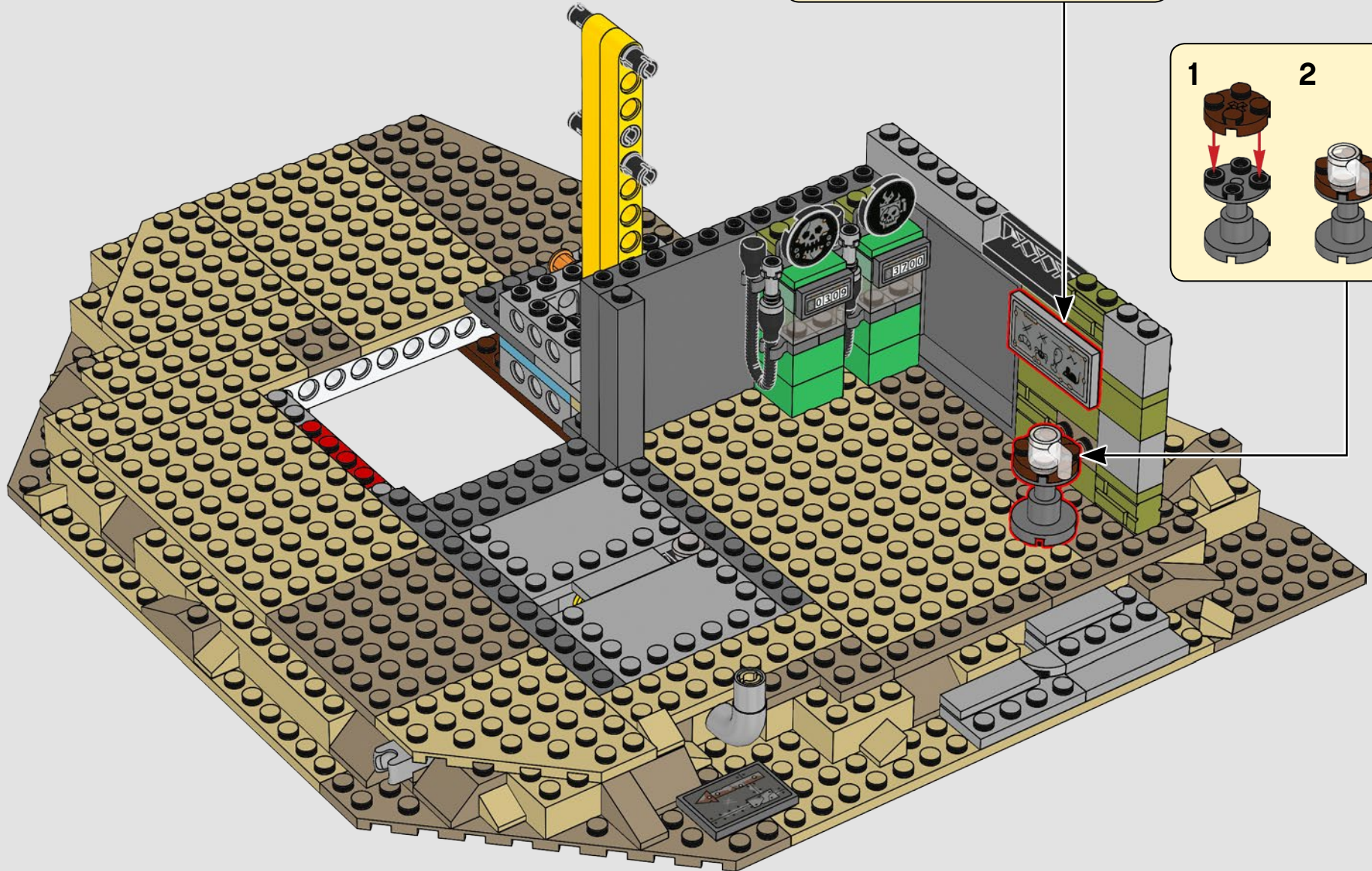
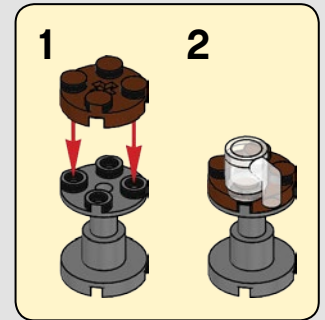
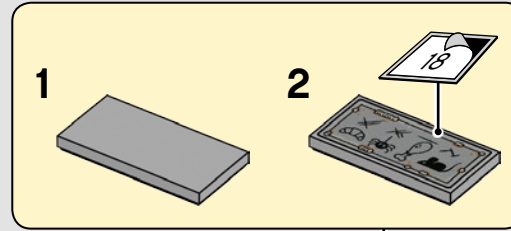

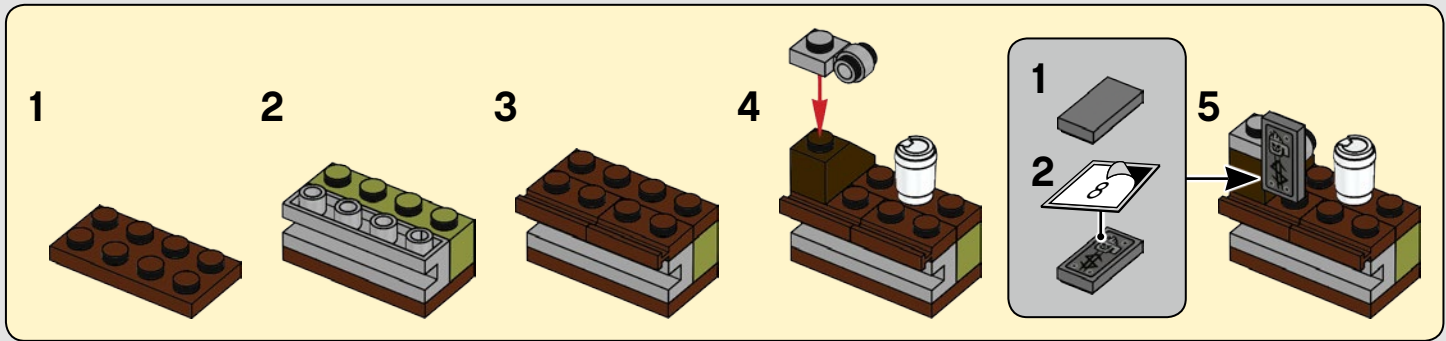
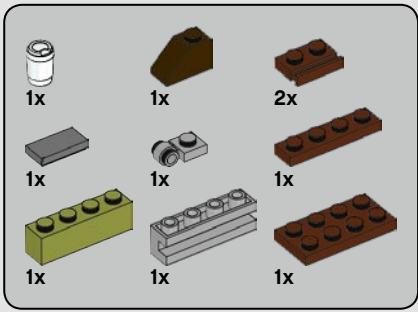

47

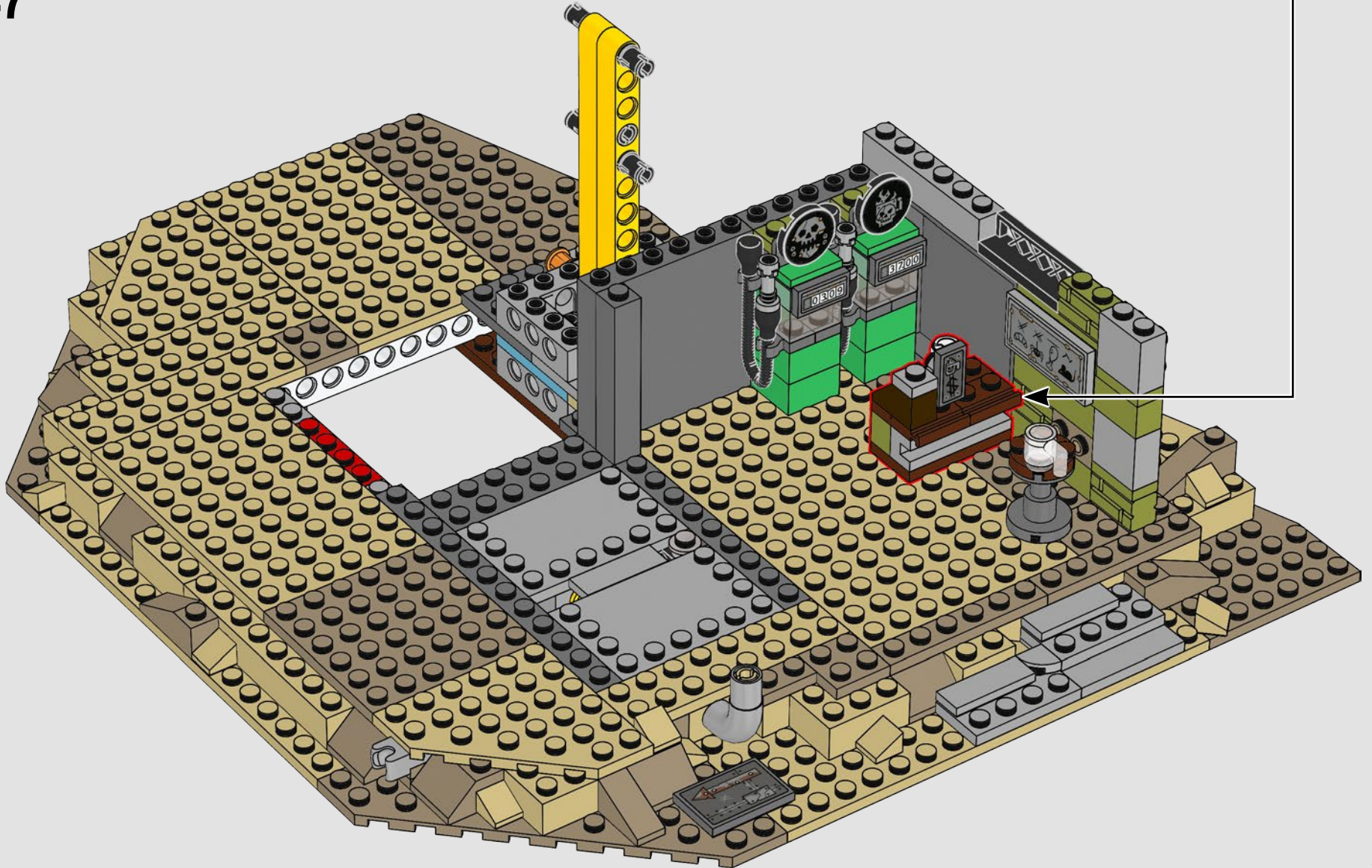

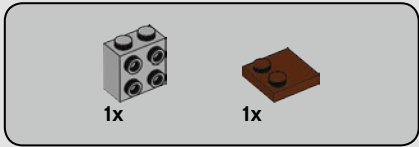

48

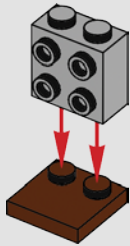

49

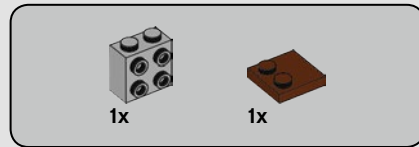
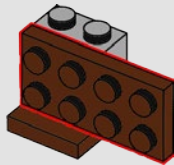

50

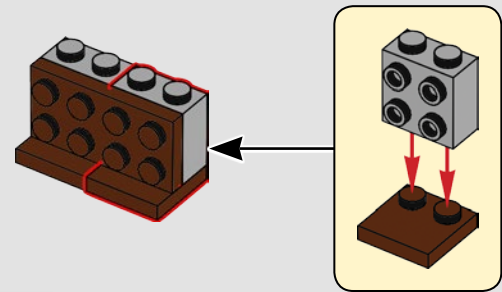

51

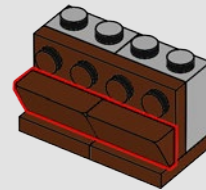

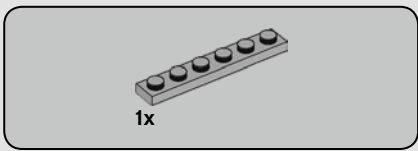

52

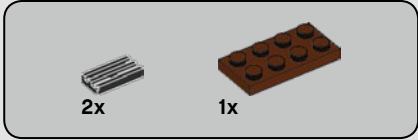
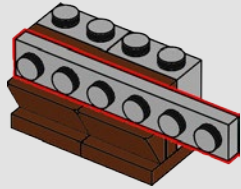

53

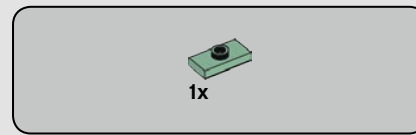
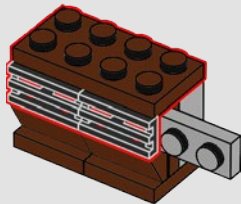

54

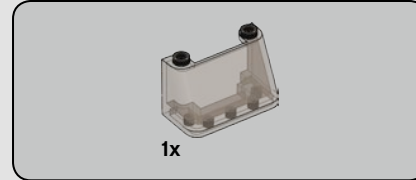
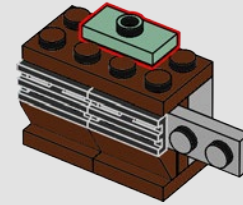

55

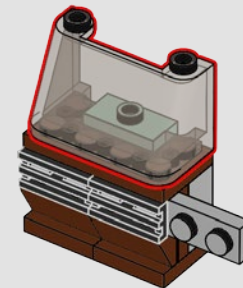



1x

56

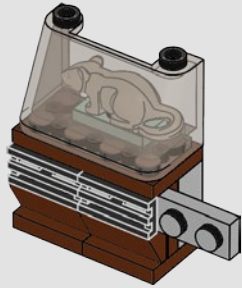

1x

57

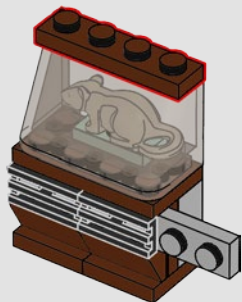

1x



1x



1x

58

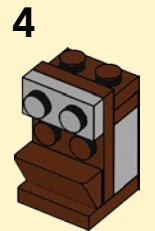
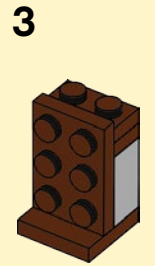
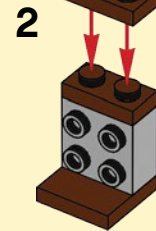
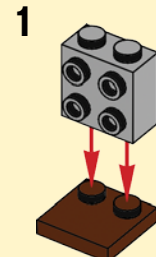
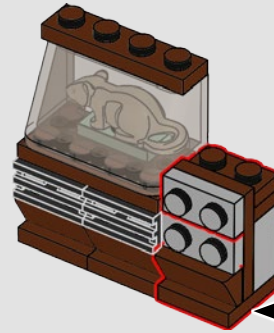

4x



1x

59

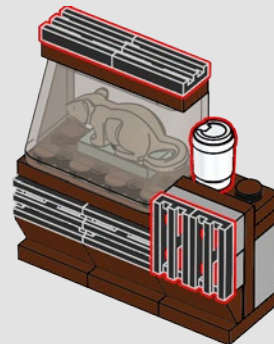

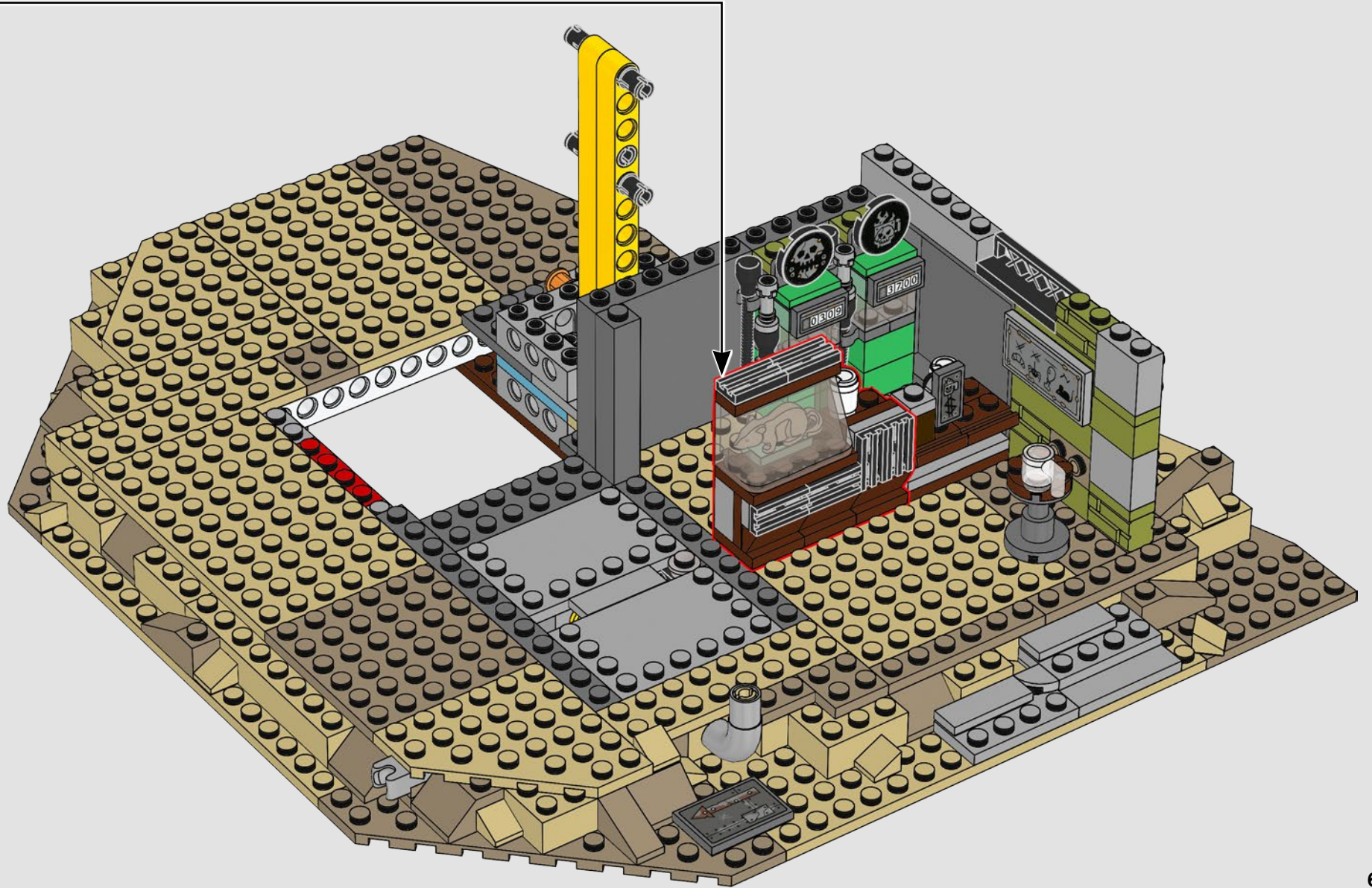

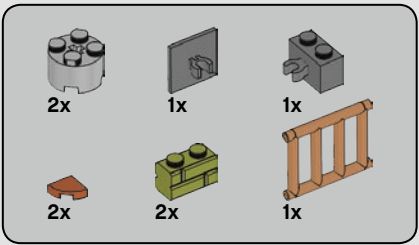

61

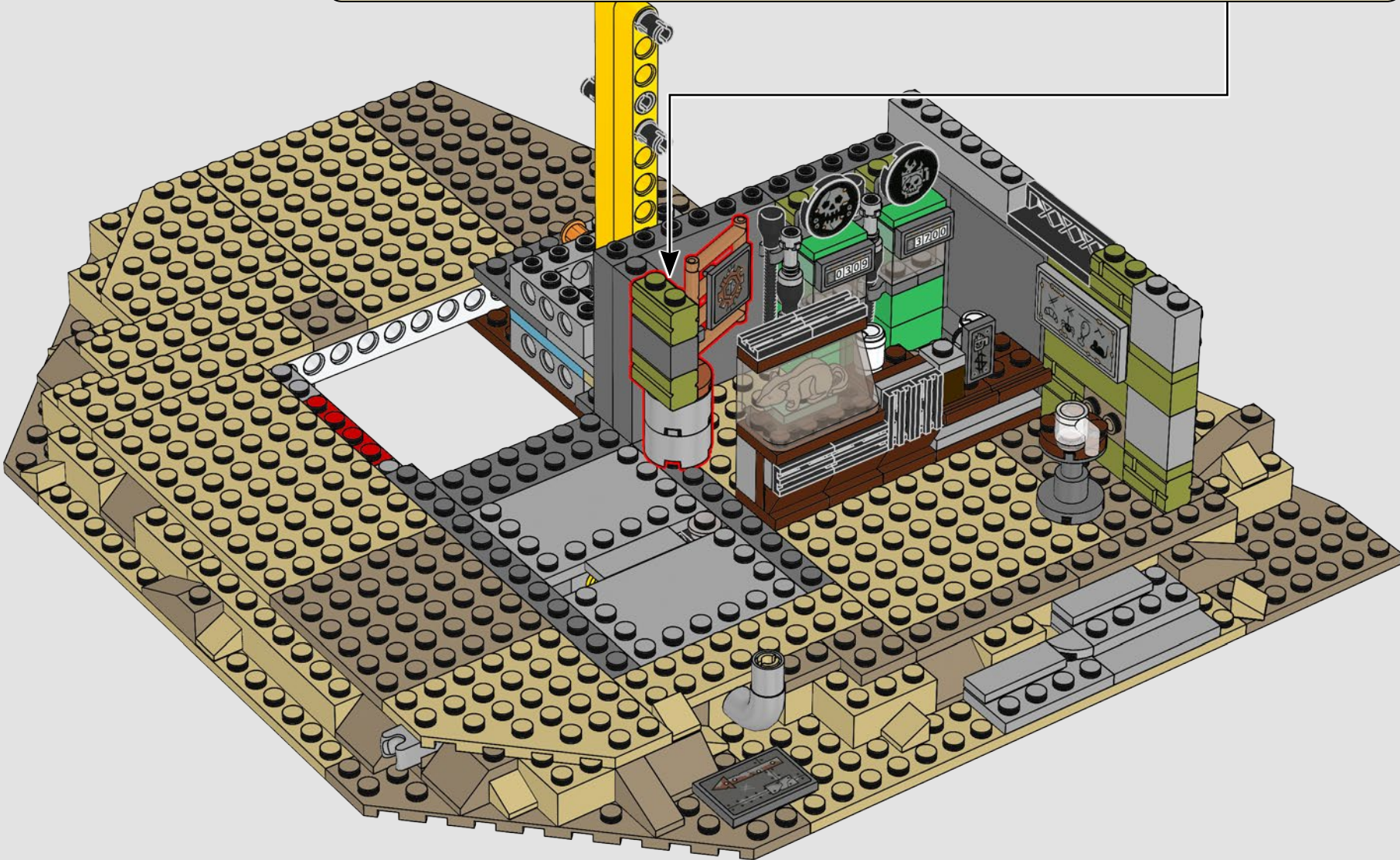
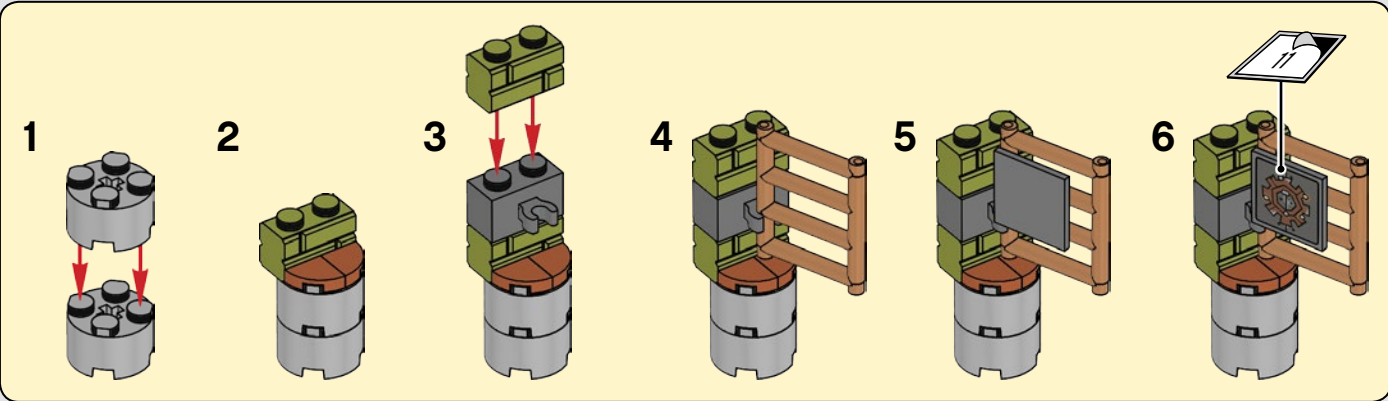



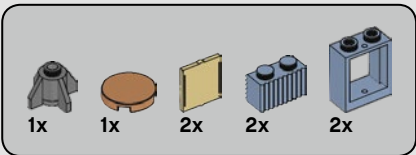

62

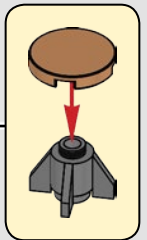
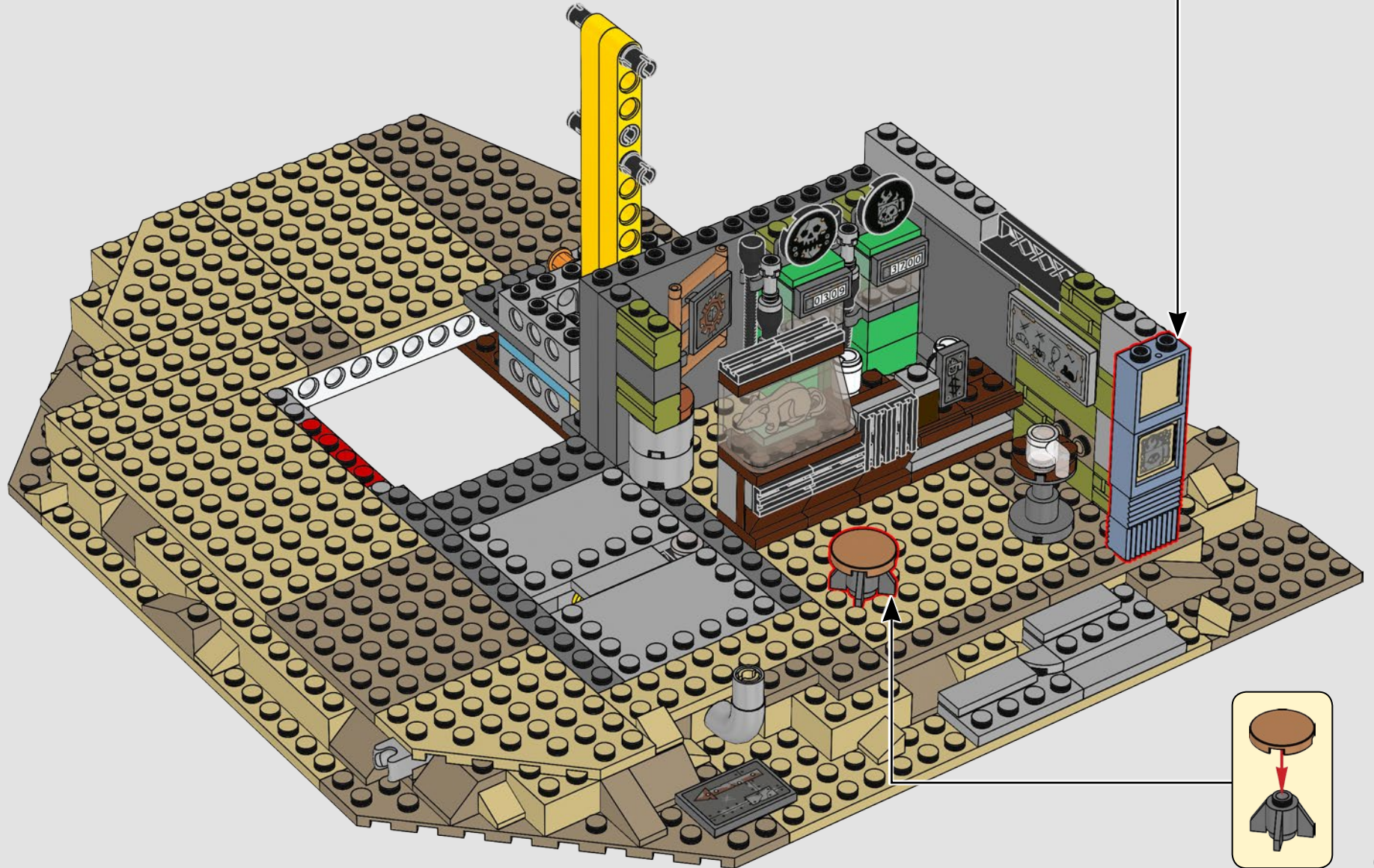
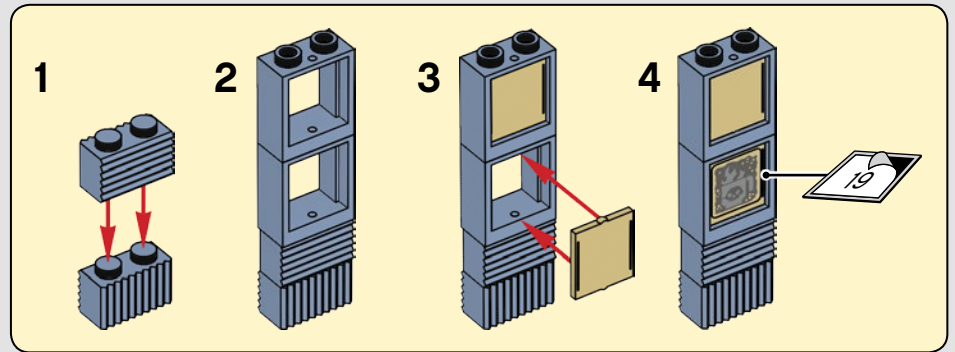

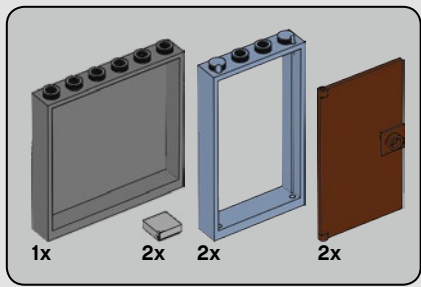

63

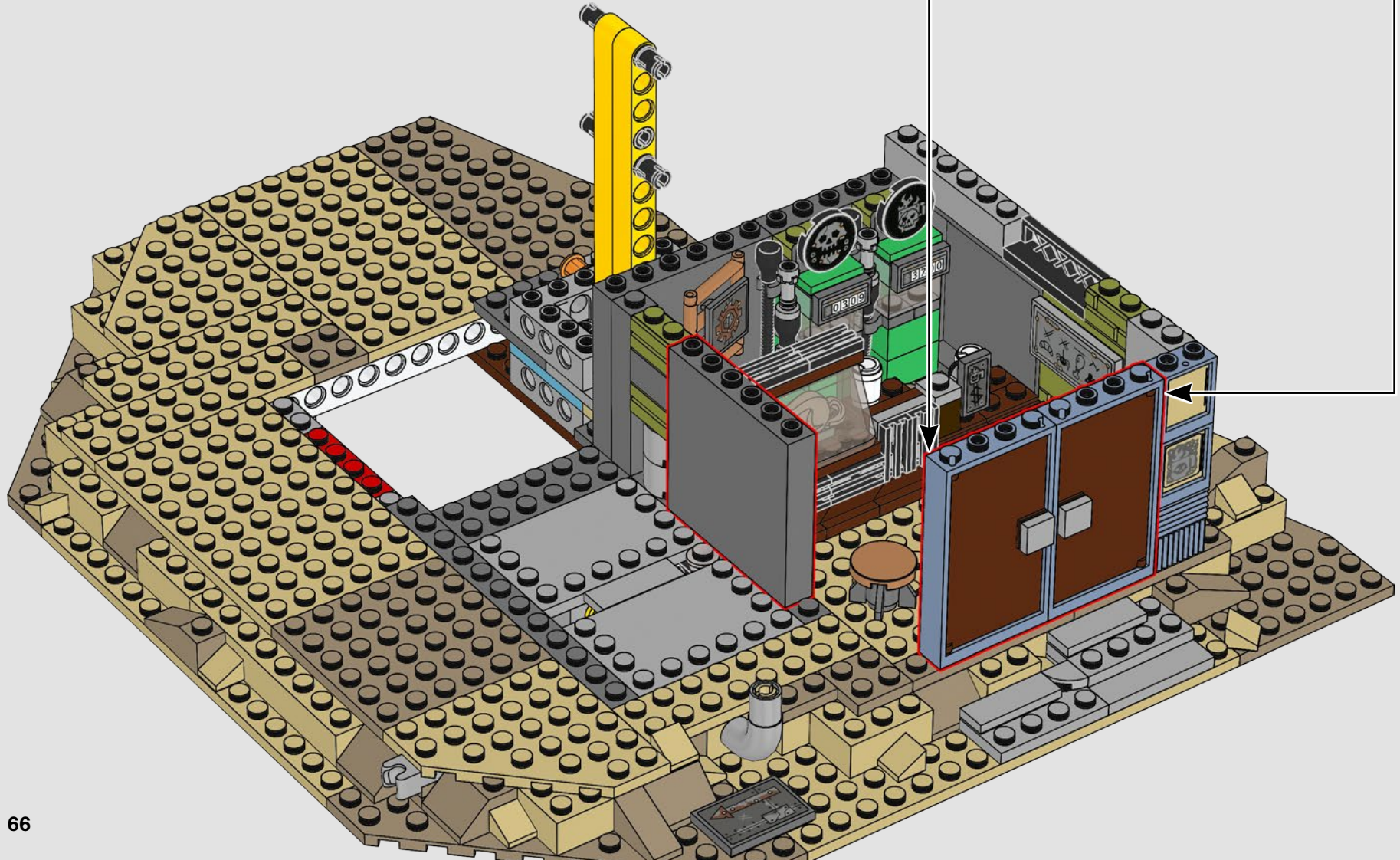
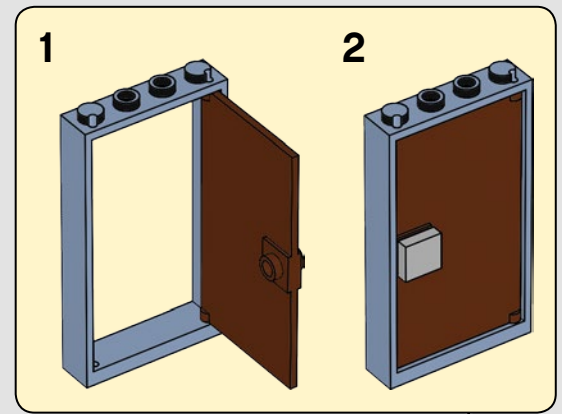
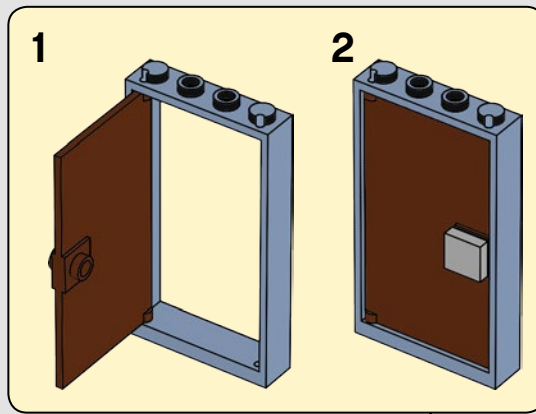

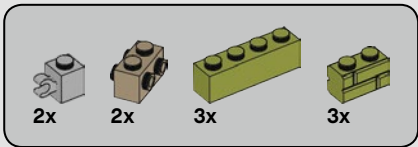

64

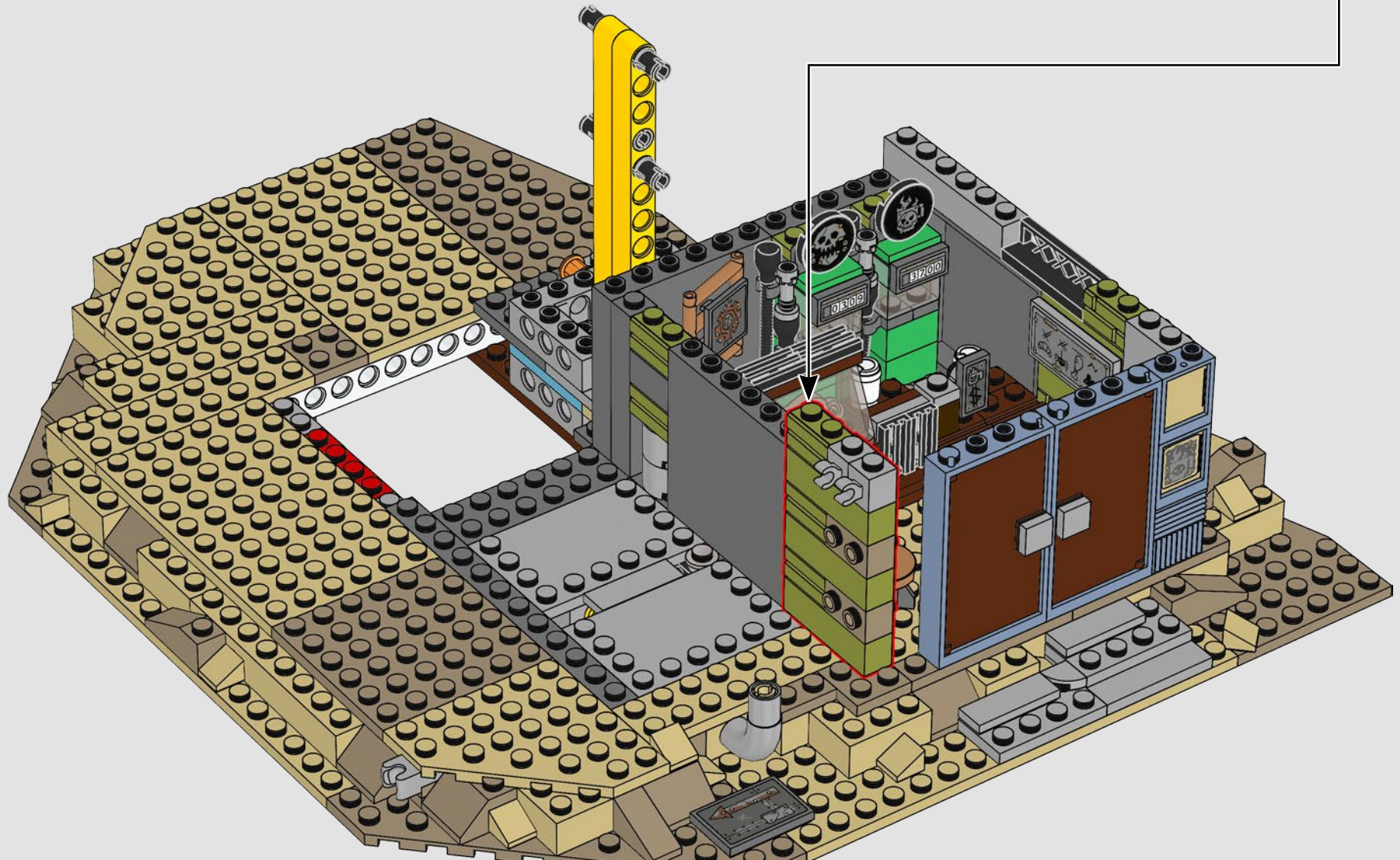
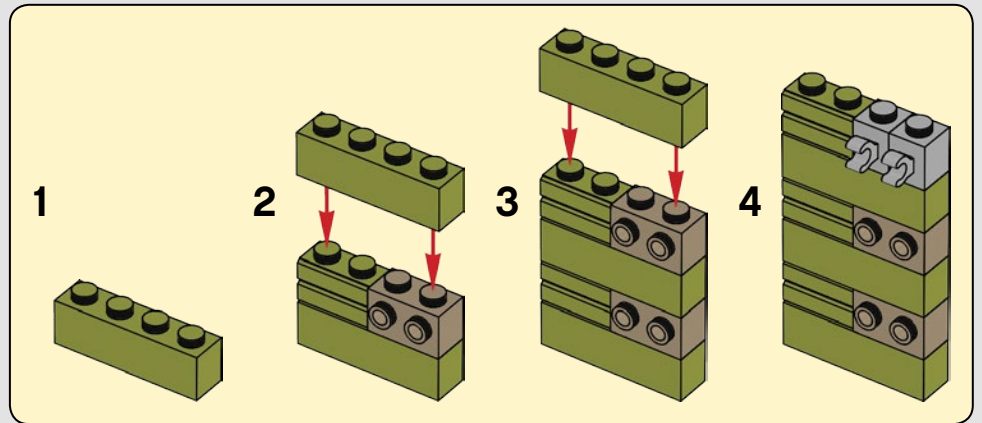

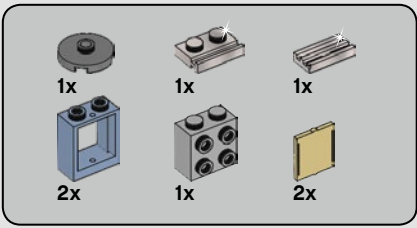

65

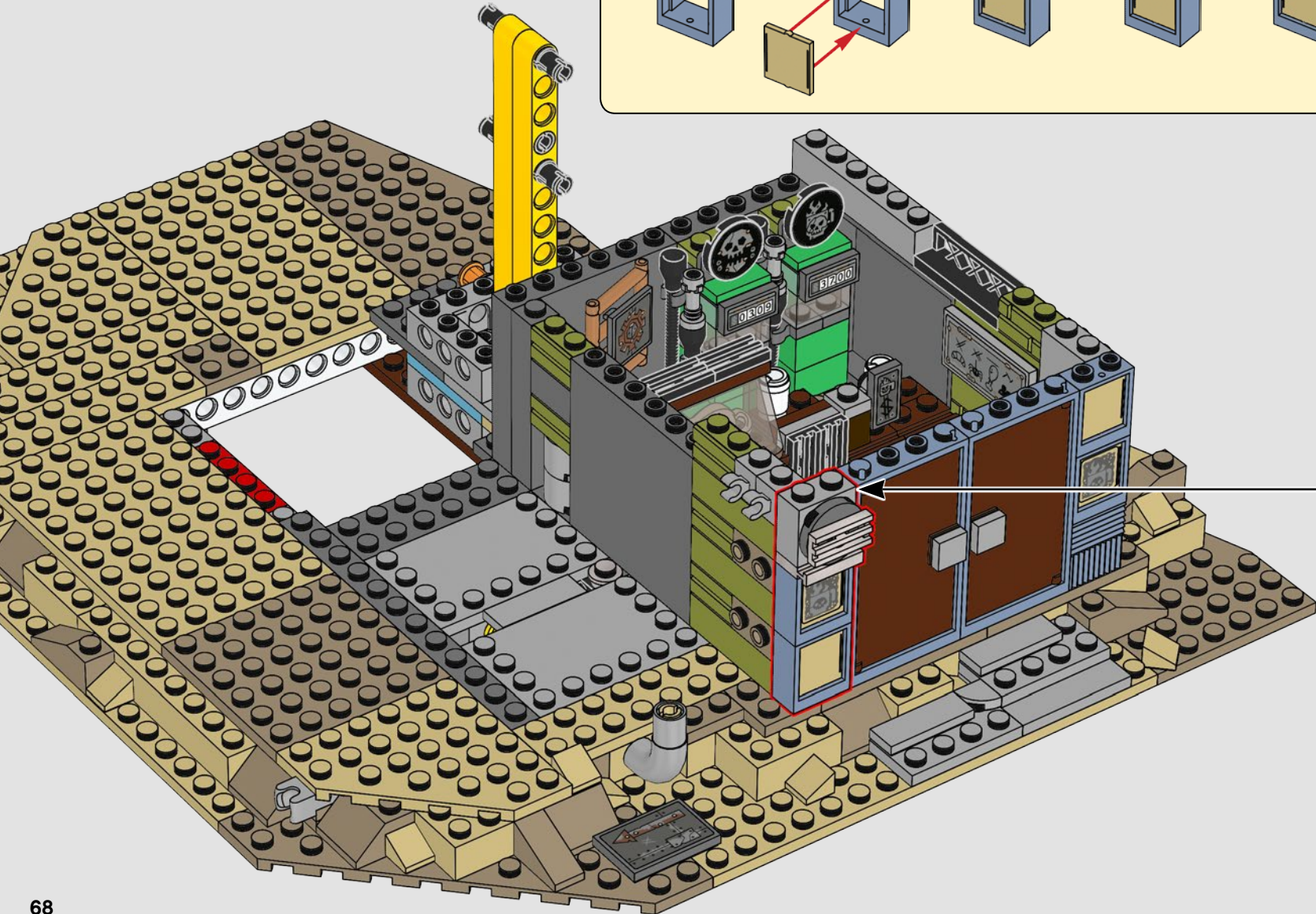
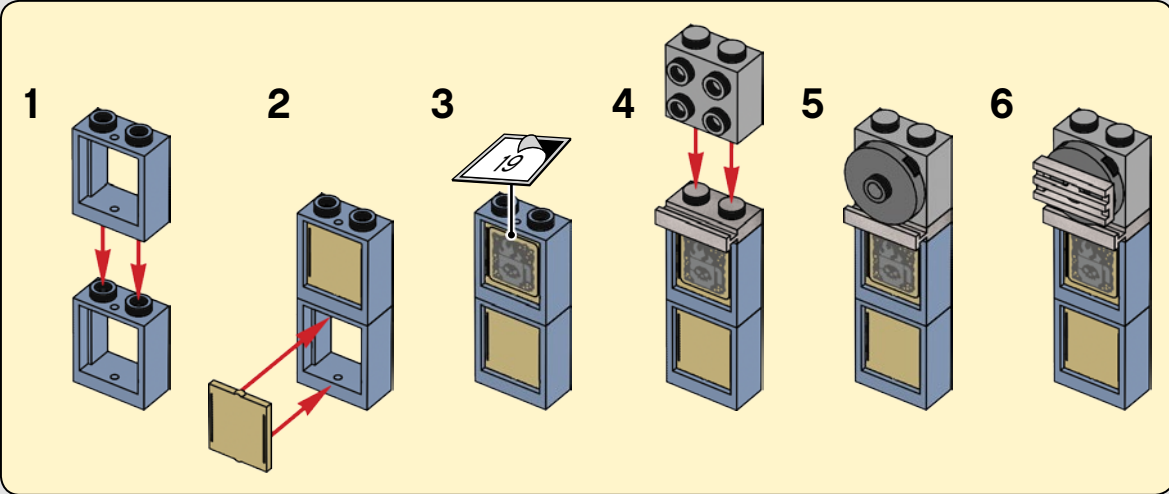

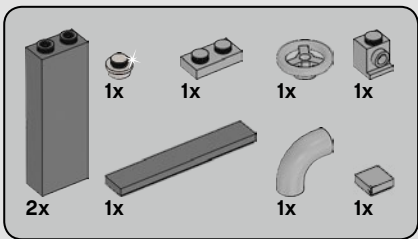

66

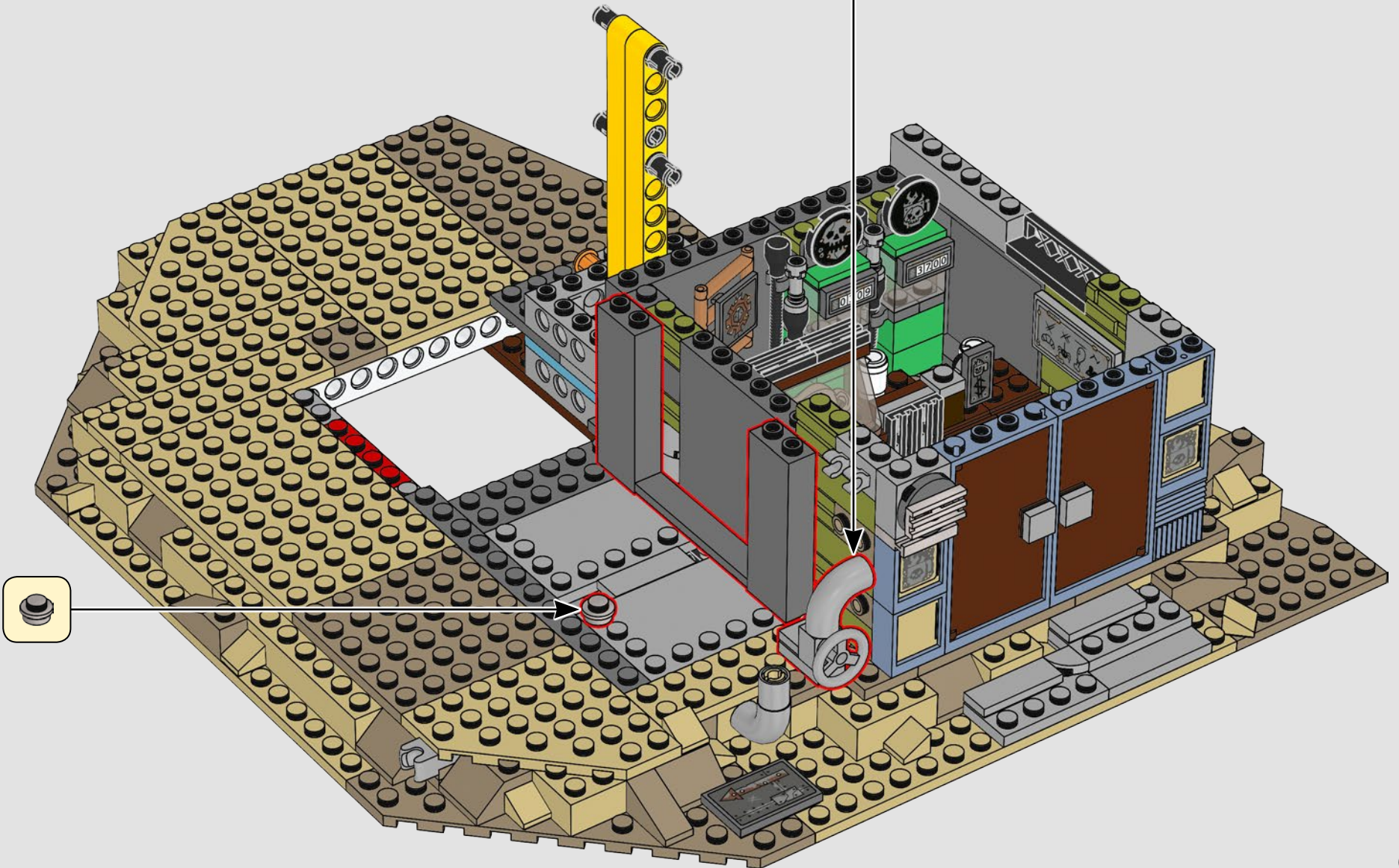
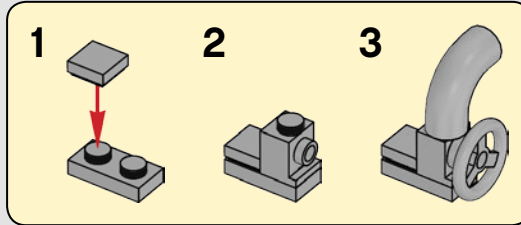

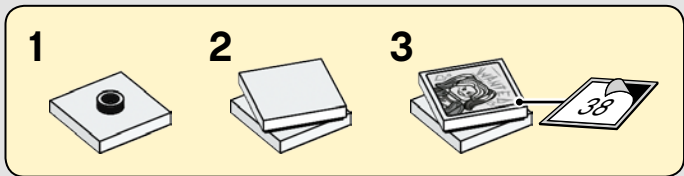
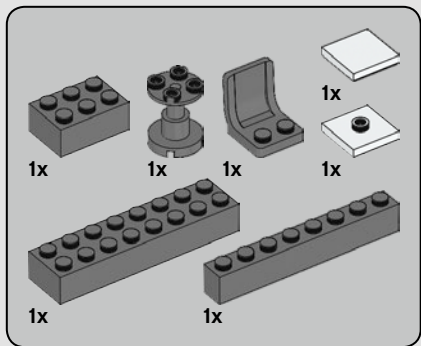

67

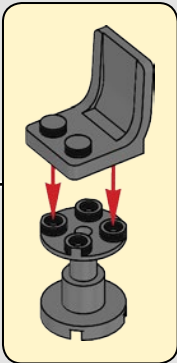
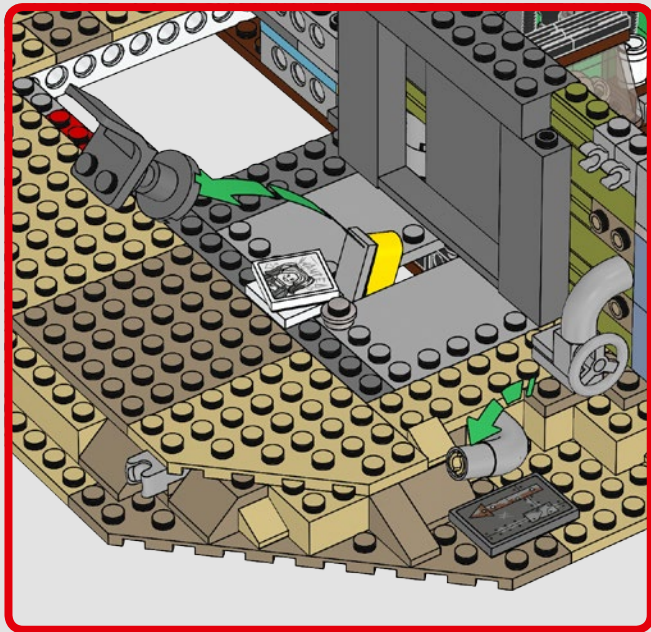
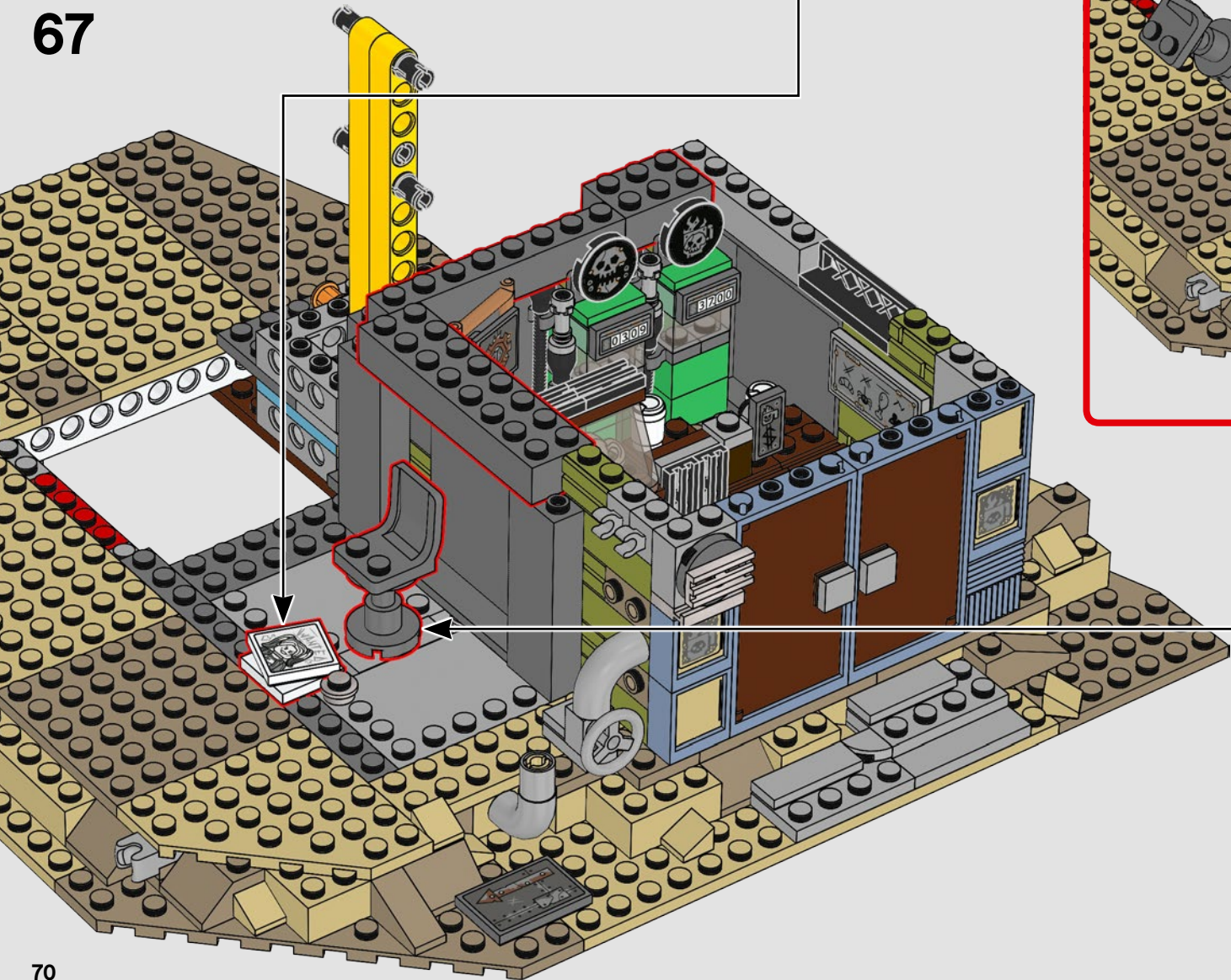

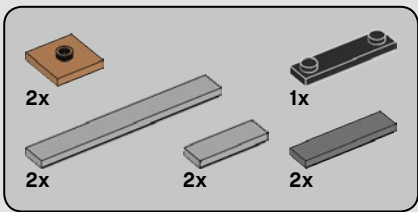

68

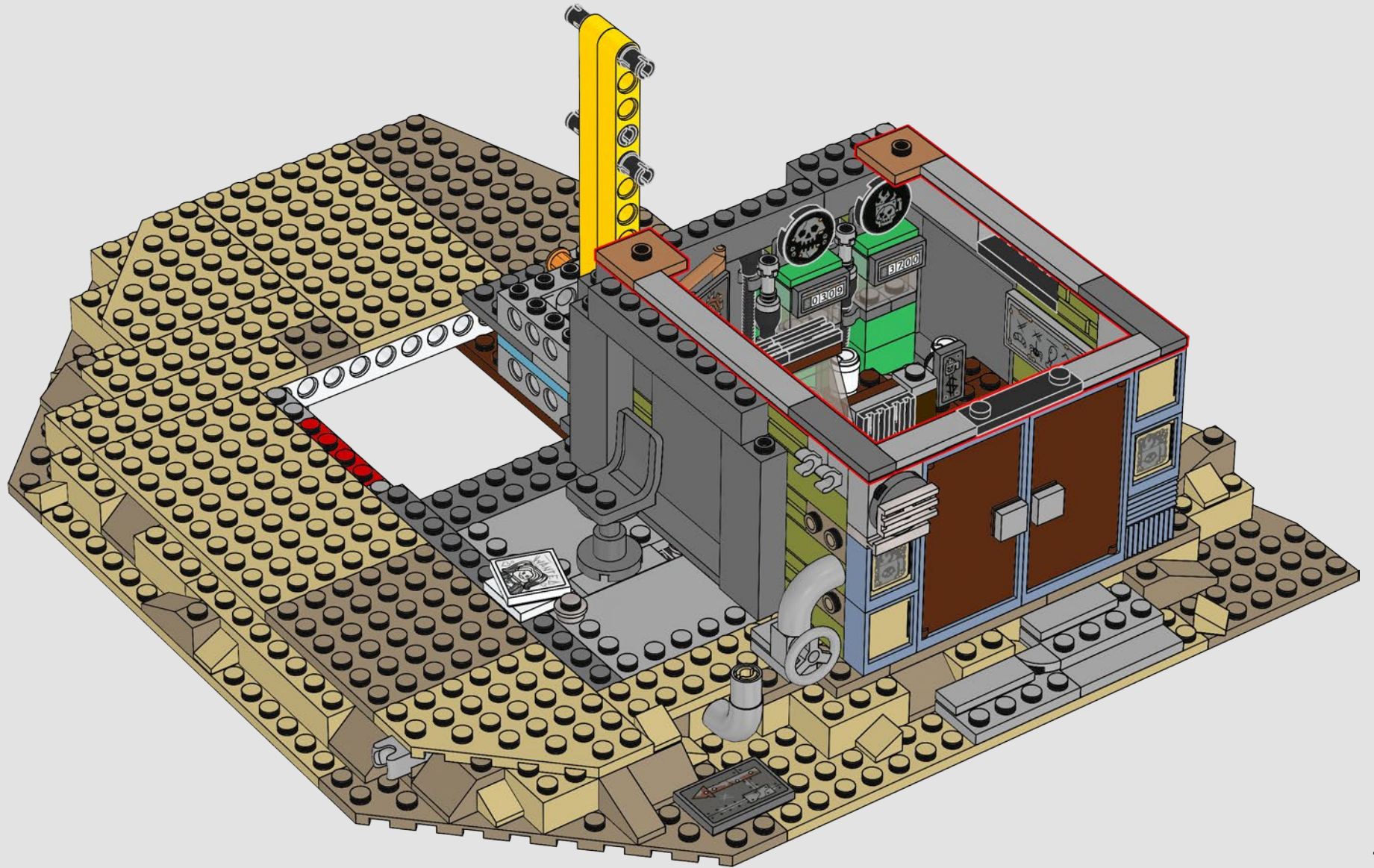

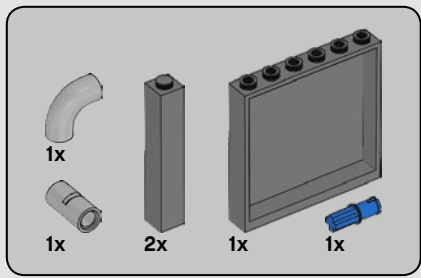

69

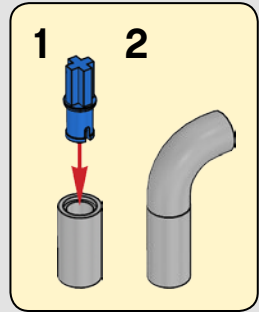
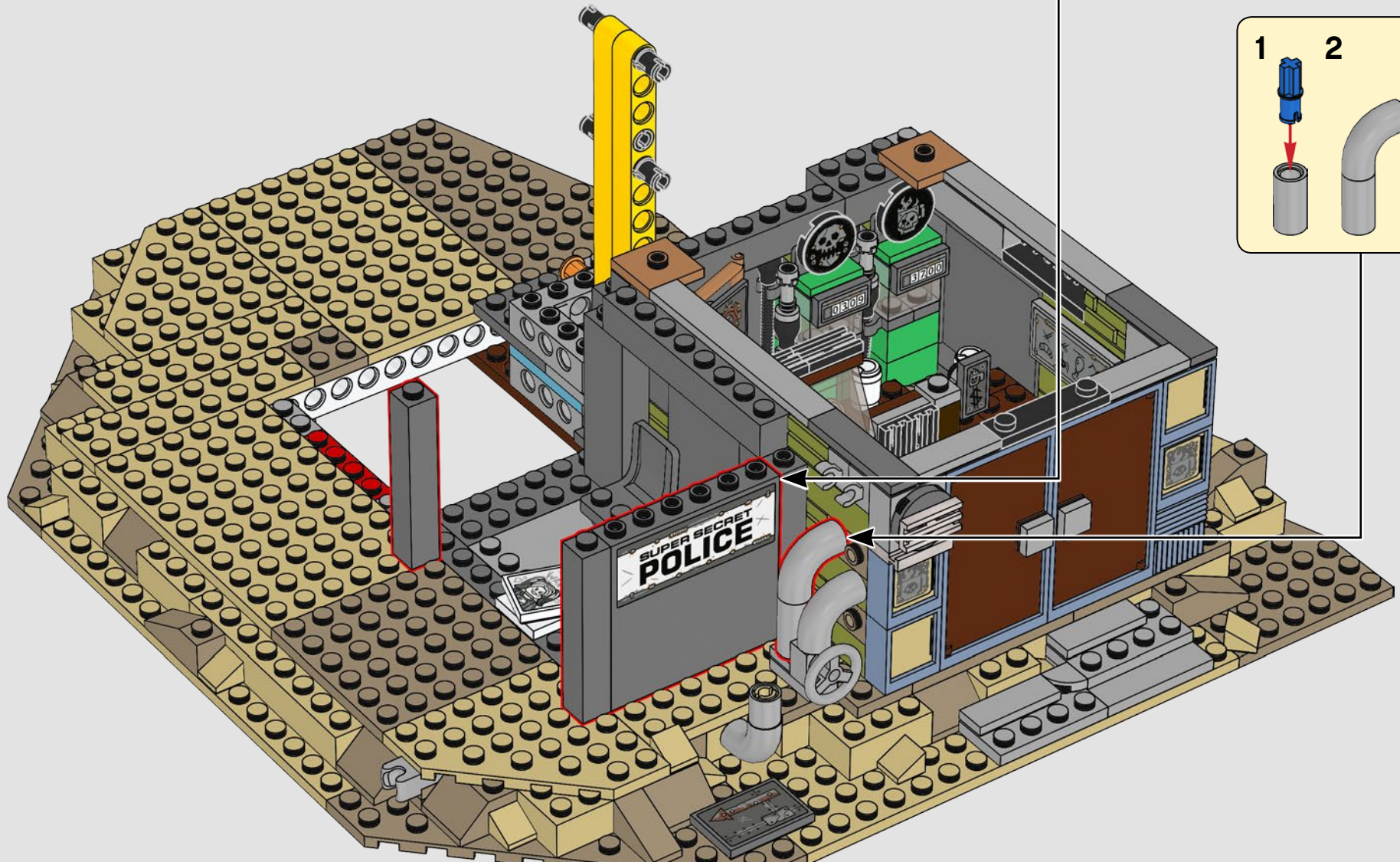
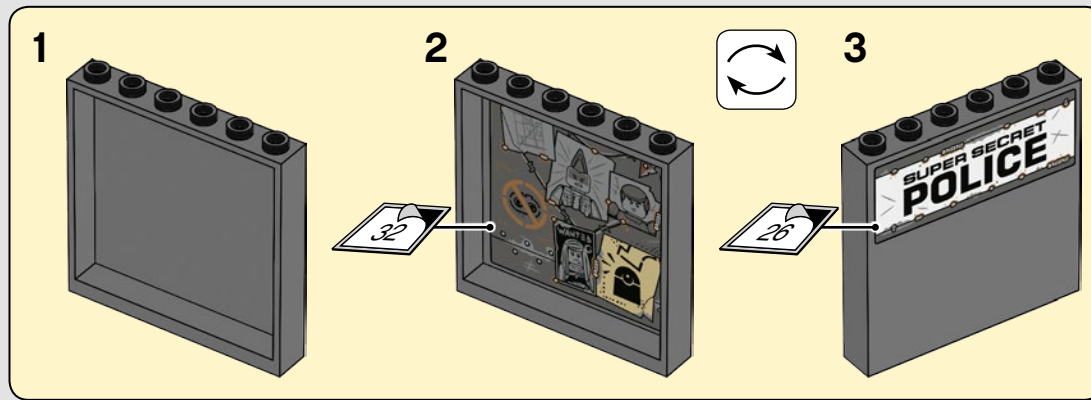



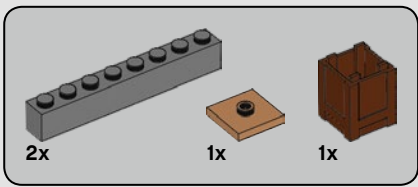

70

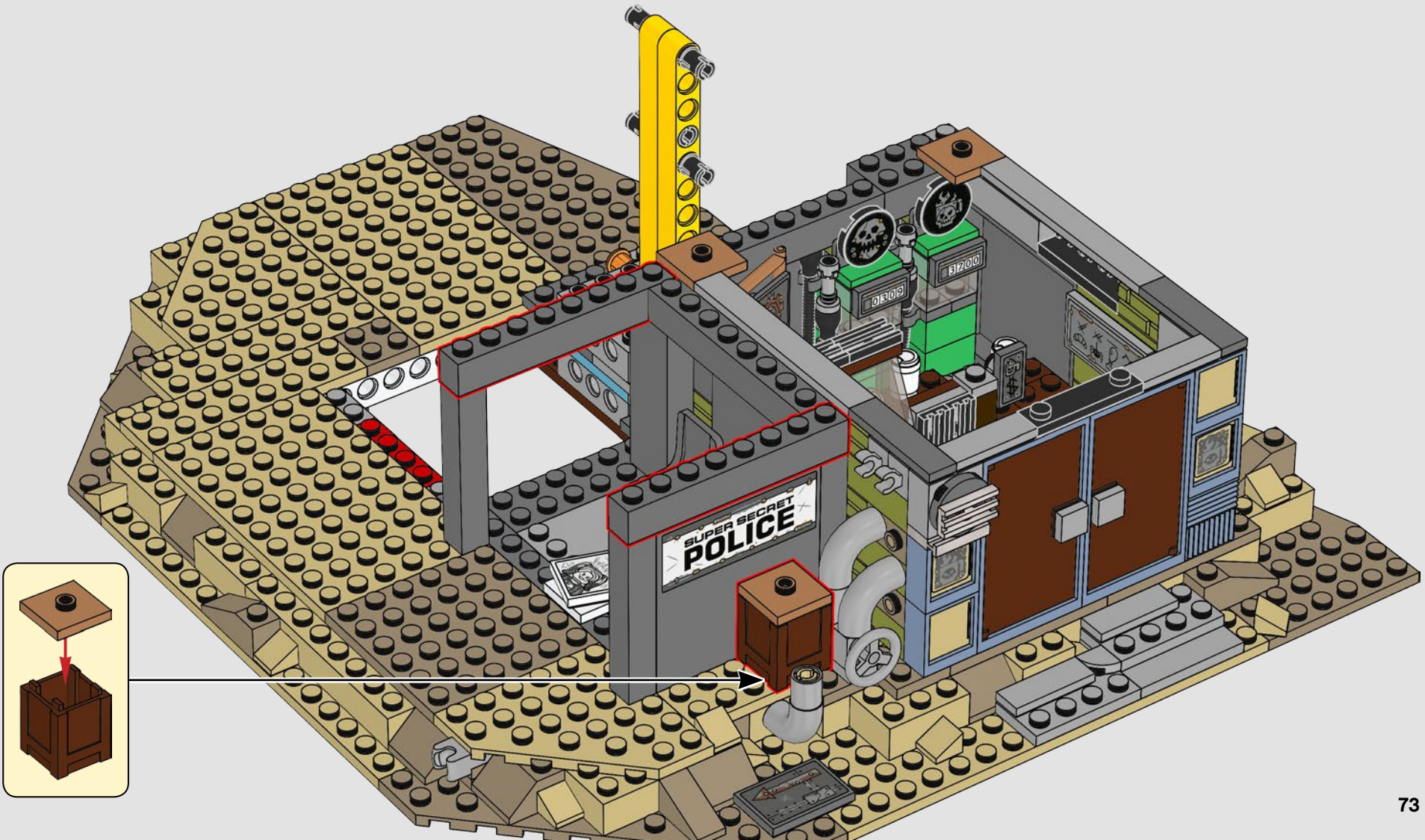

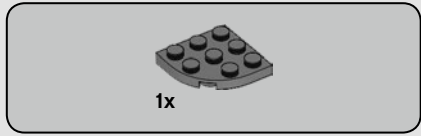

71

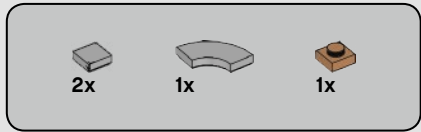

72

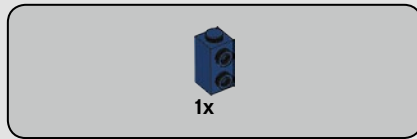

73

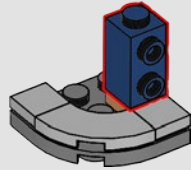

74

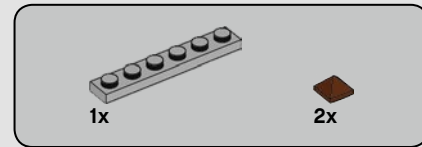
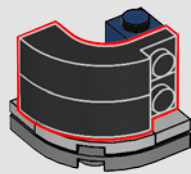

75

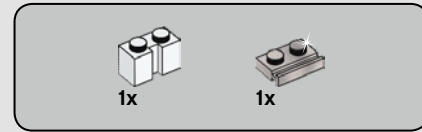
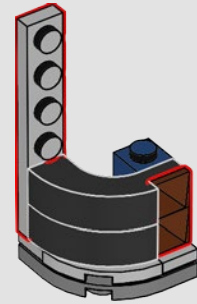

76

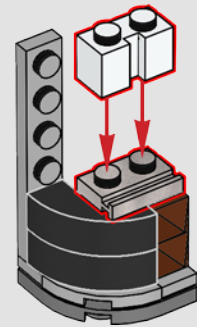

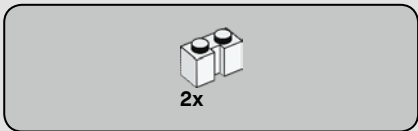

77

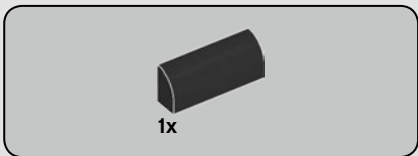
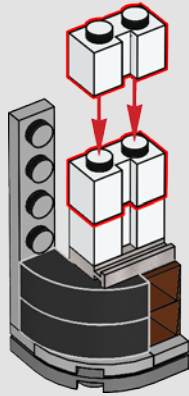

78

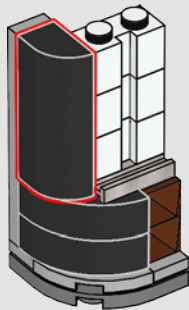

79

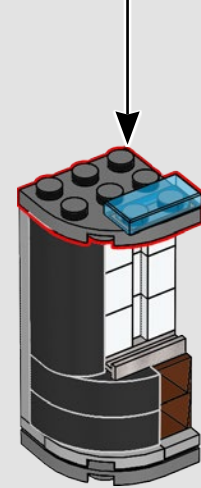
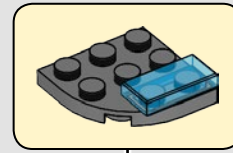

80

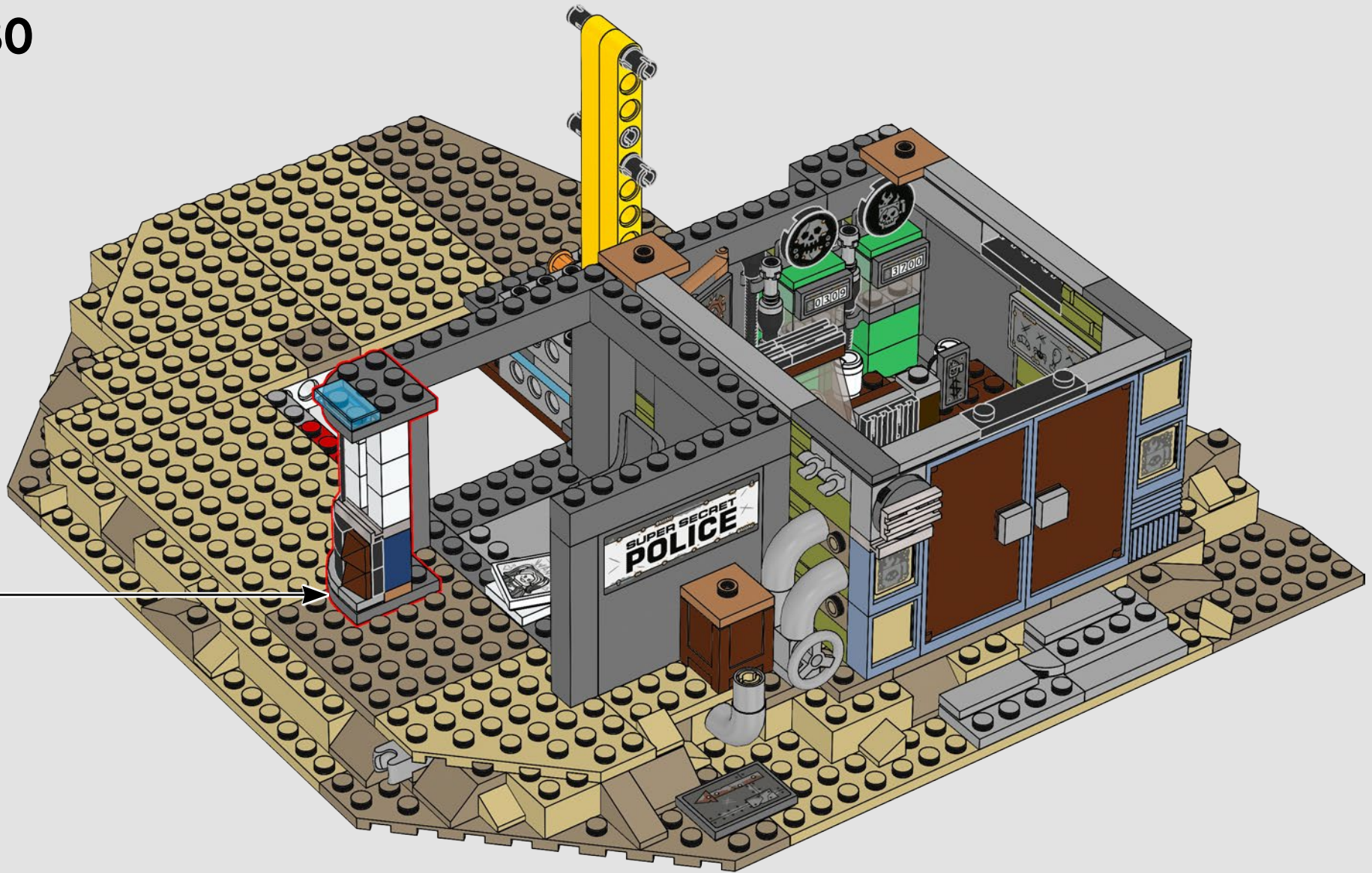

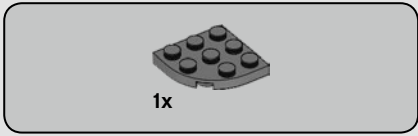

81

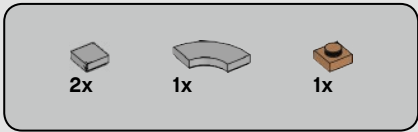

82

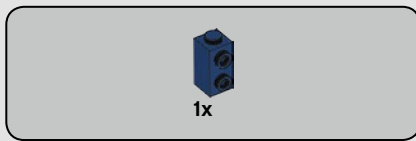

83

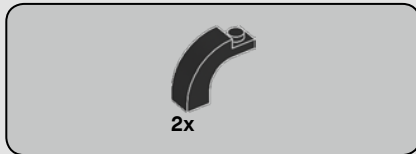
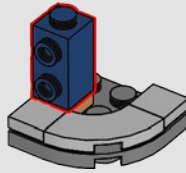

84

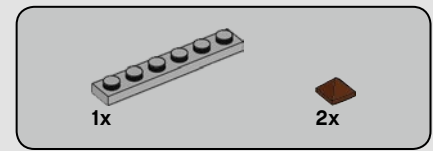
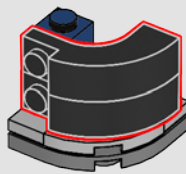

85

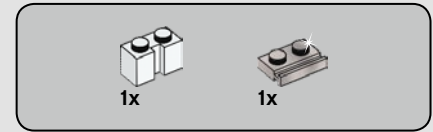
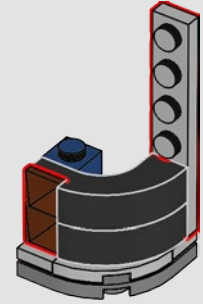

86

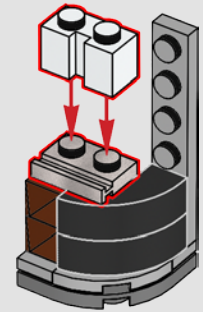



2x

87

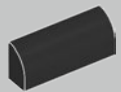
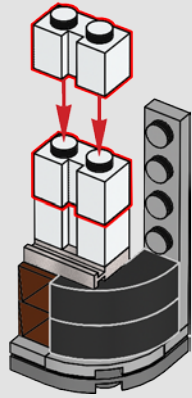

1x

88

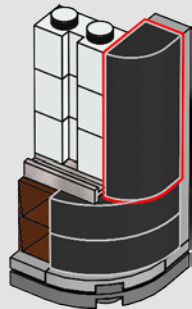

1x



1x

89

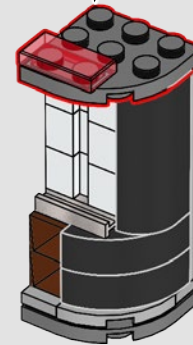

90

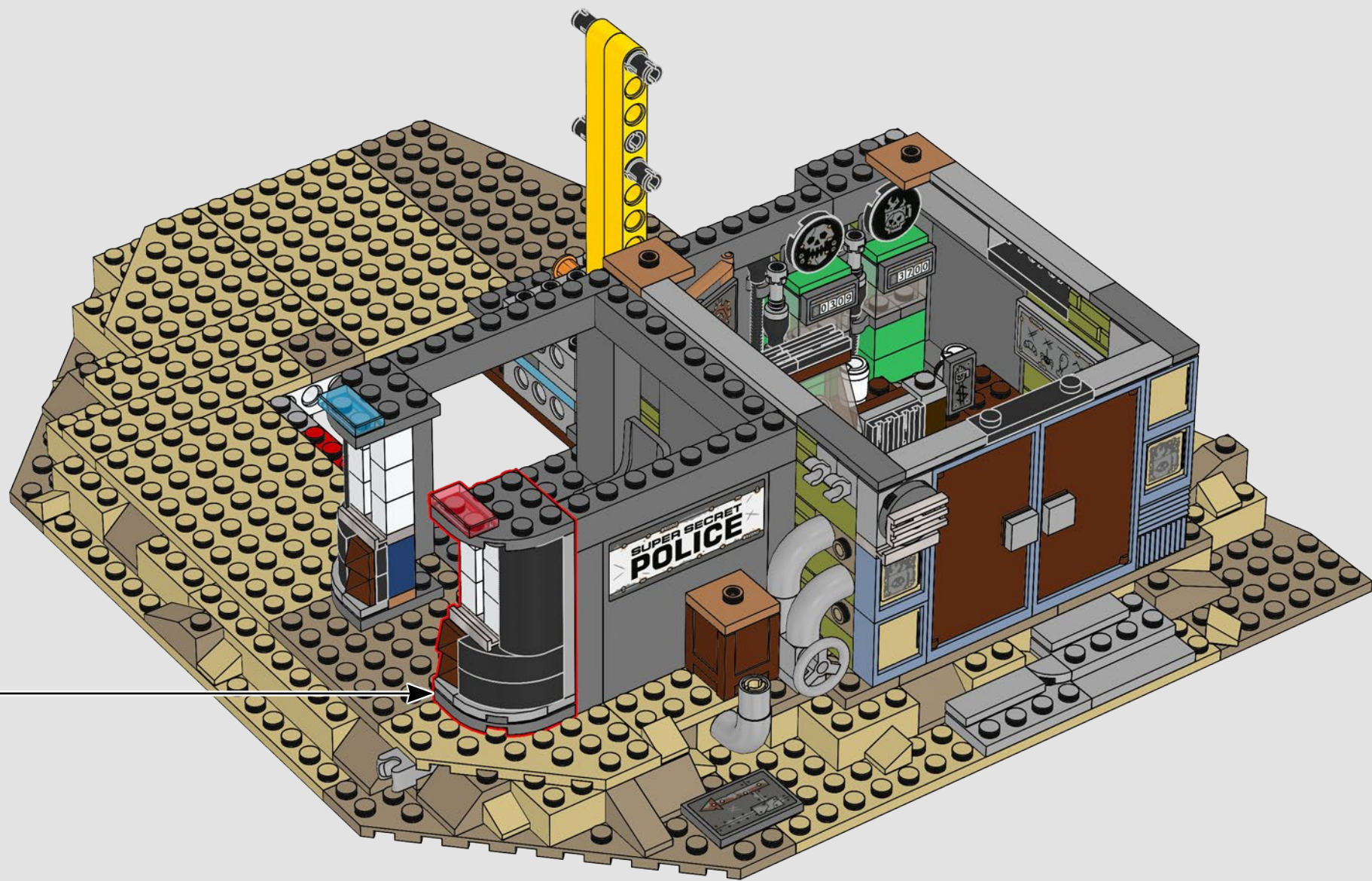

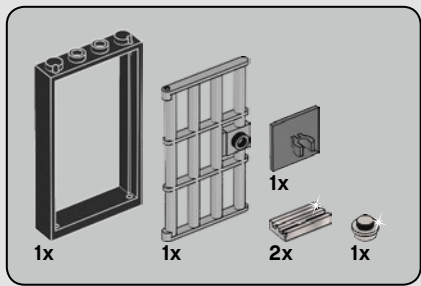

91

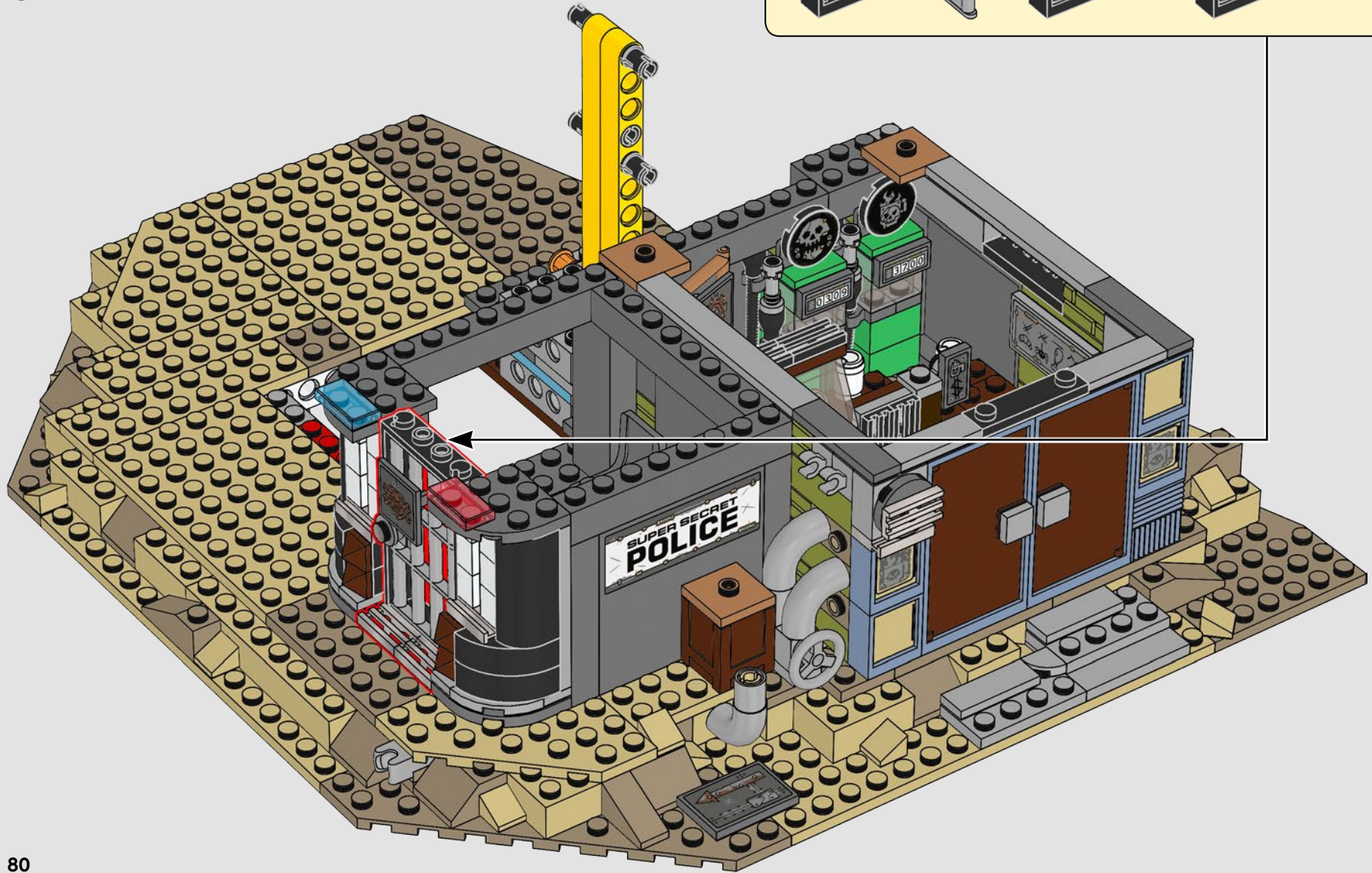
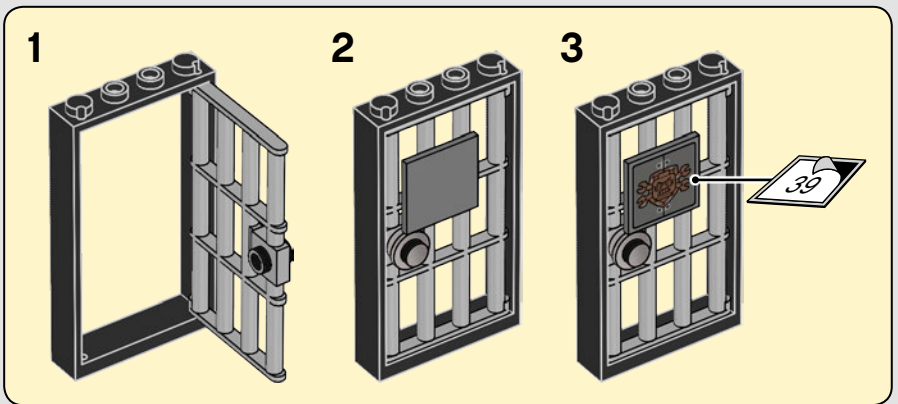



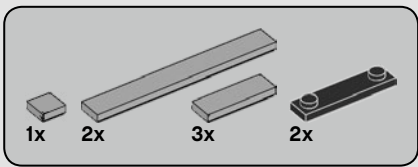

92

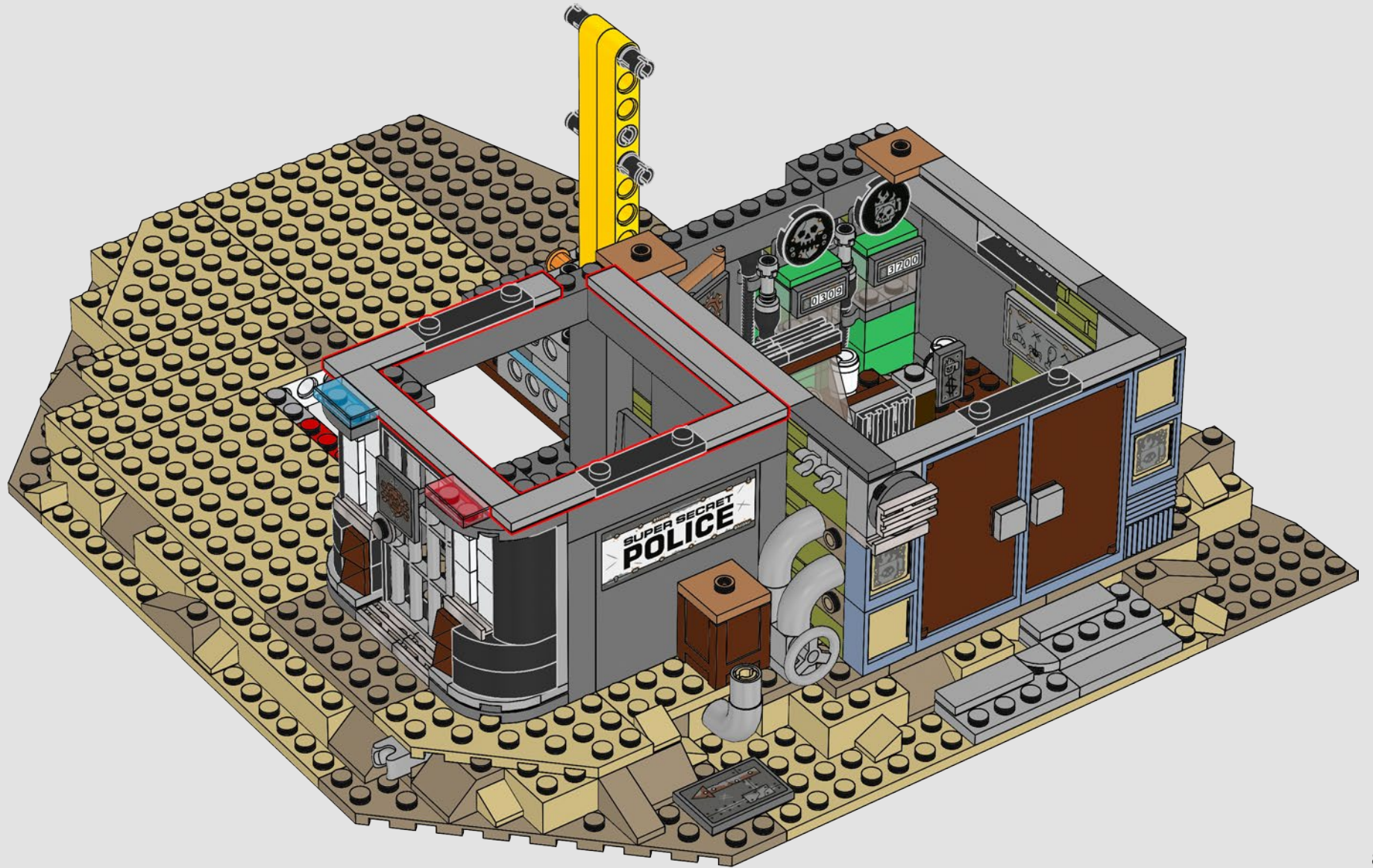

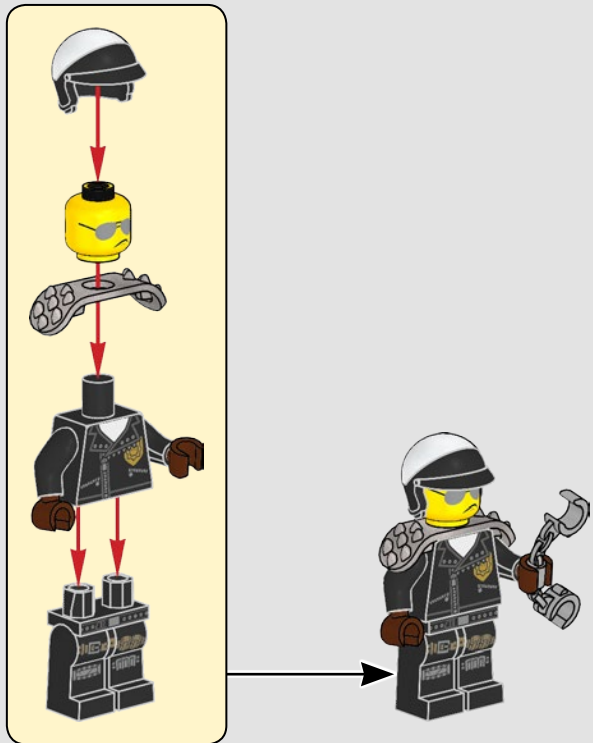
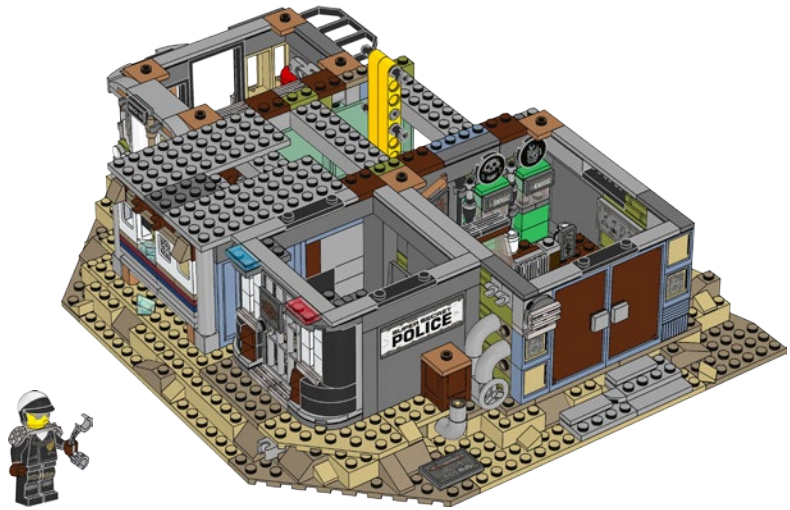
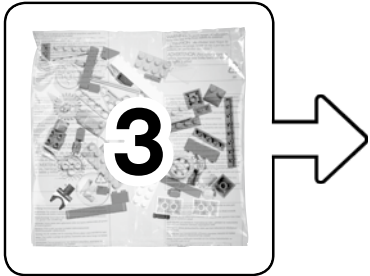

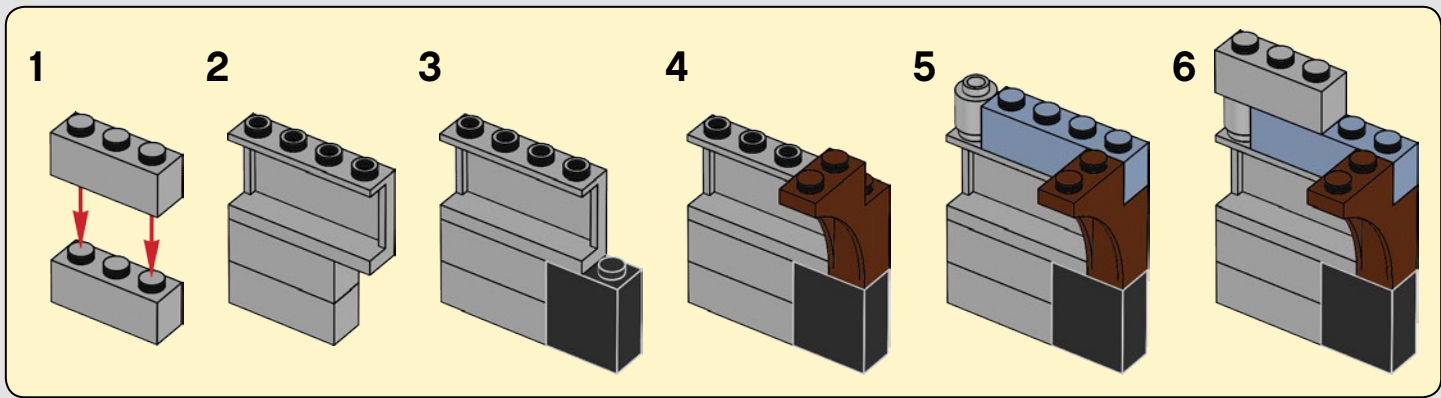
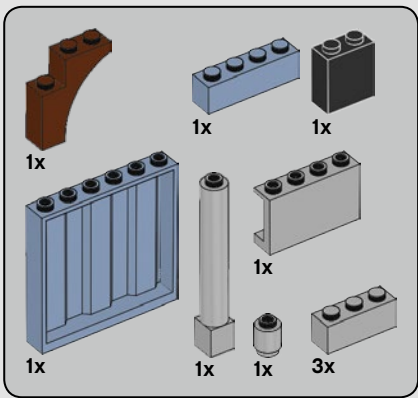

93

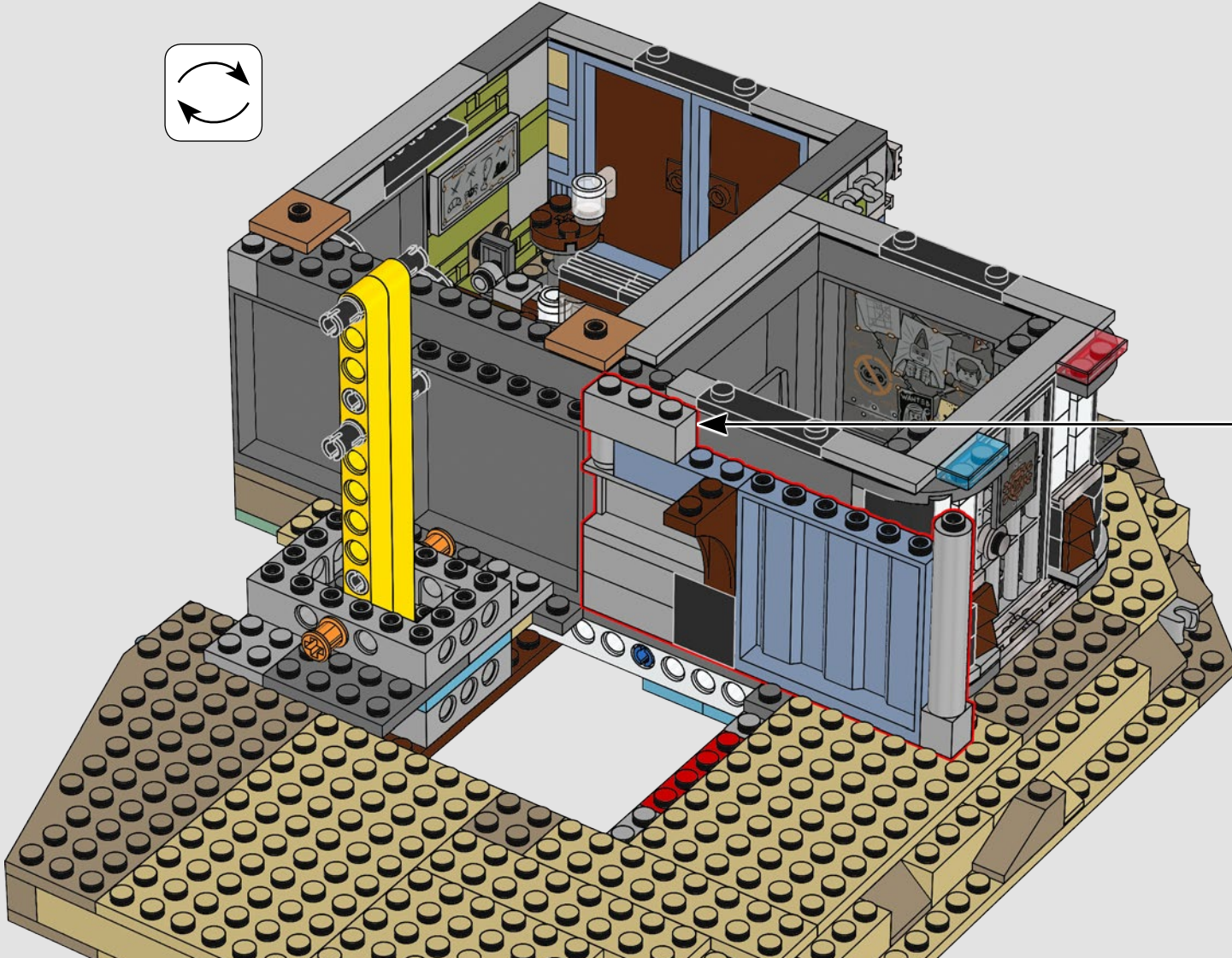
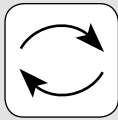

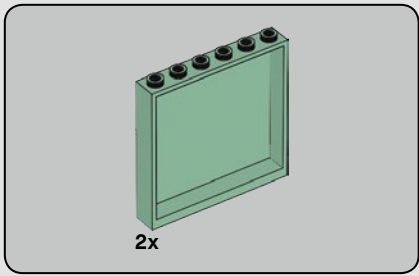

94

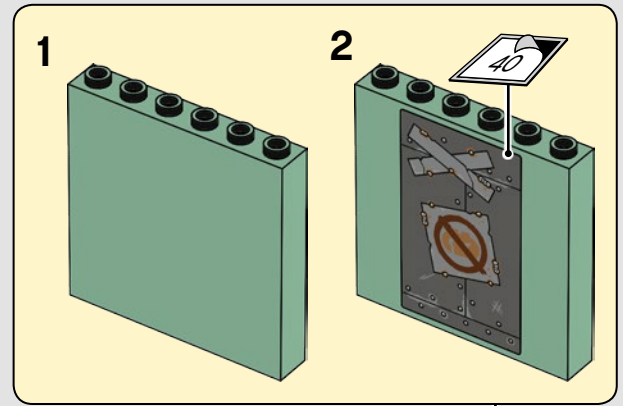
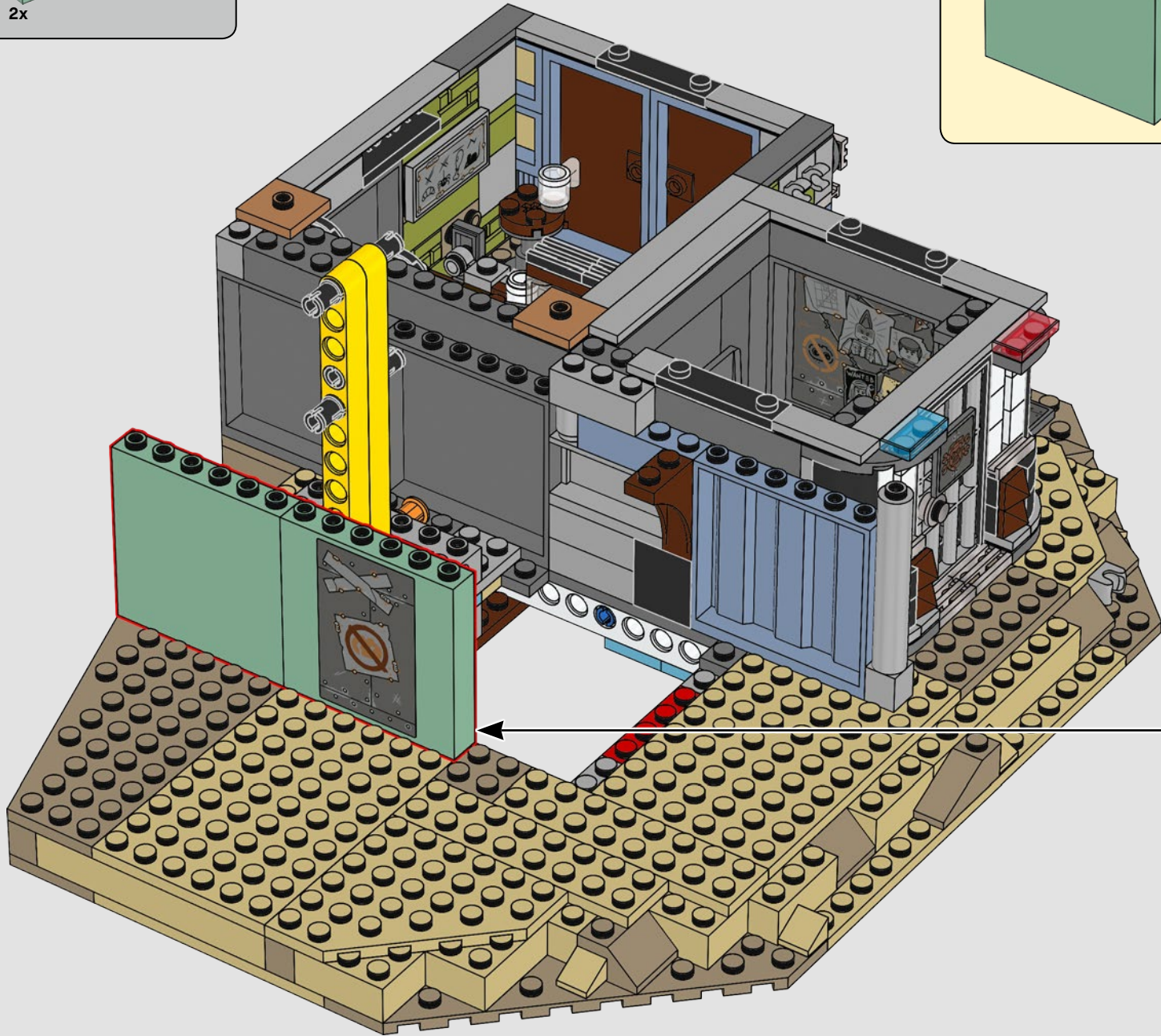

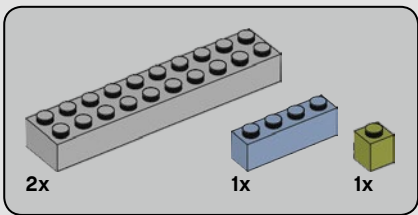

95

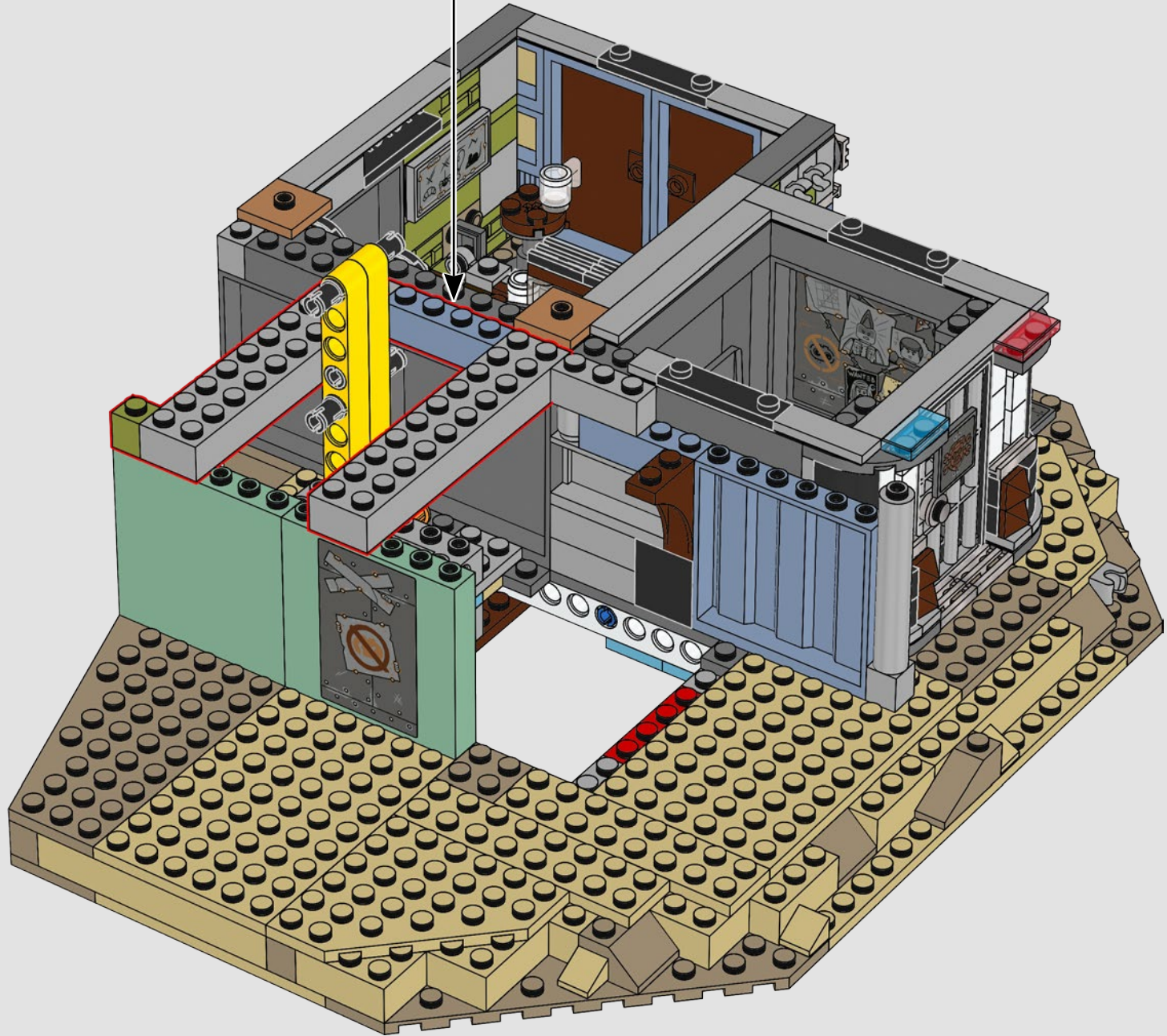
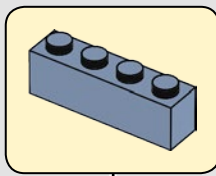

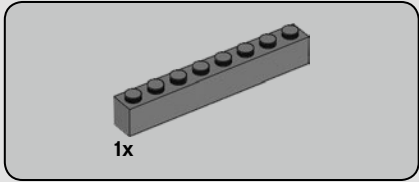
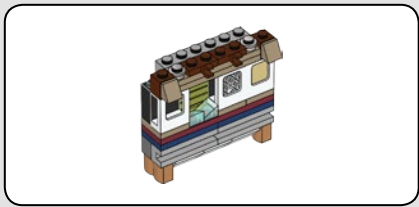

1x

96

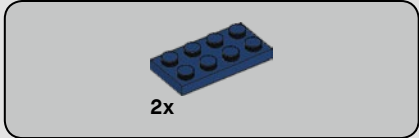
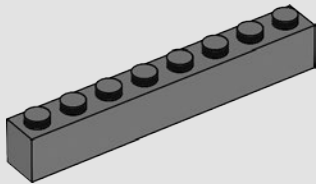

2x

97

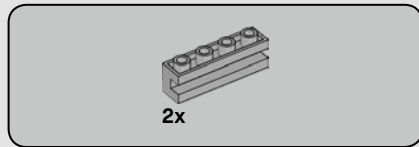
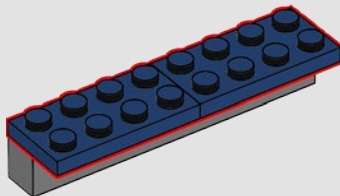

2x

98

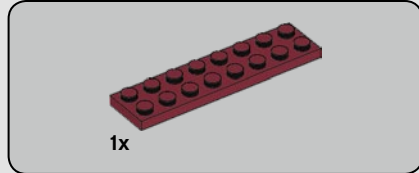
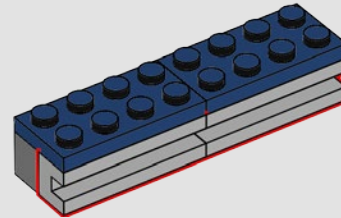

1x

99

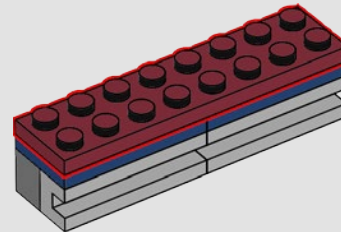

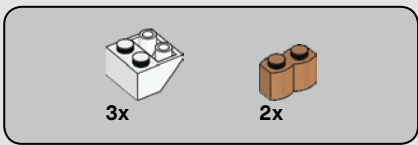

100

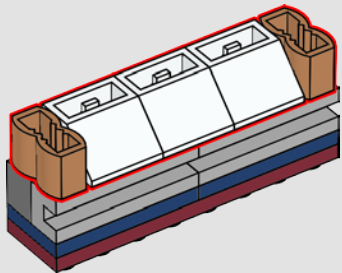
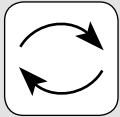

101

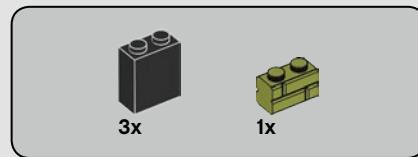
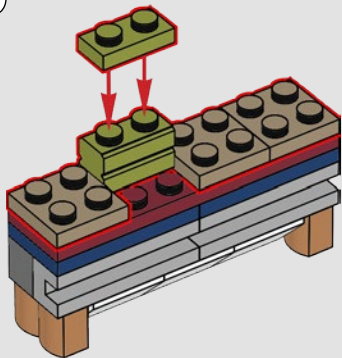
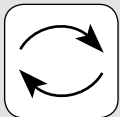

102

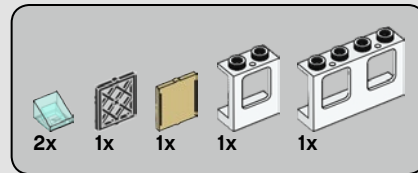
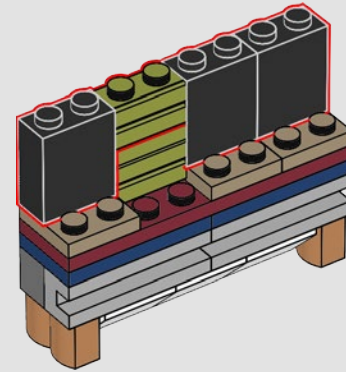

103

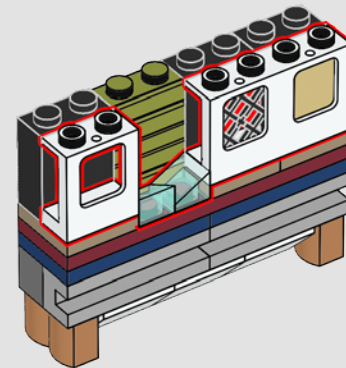
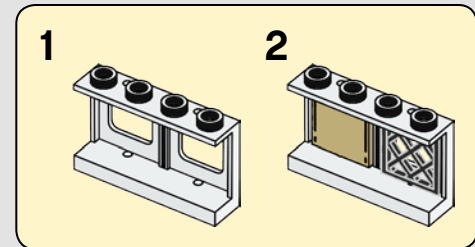

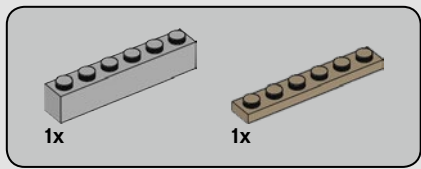

104

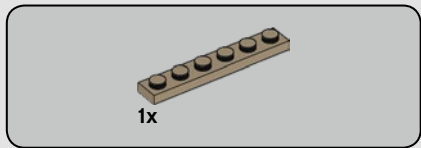
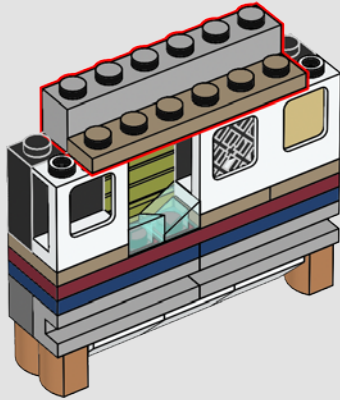

105

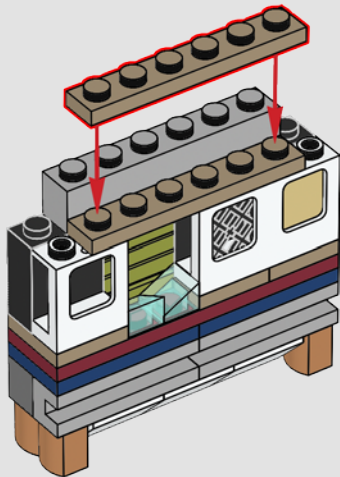

106

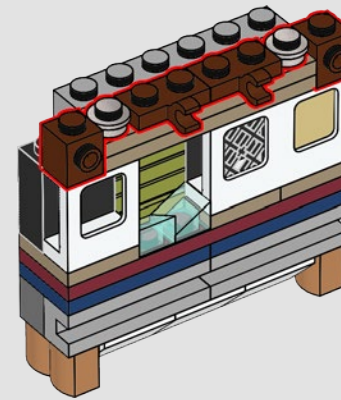

107

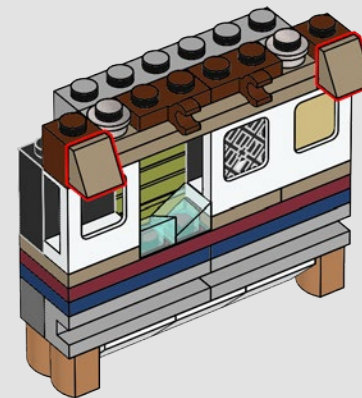



108

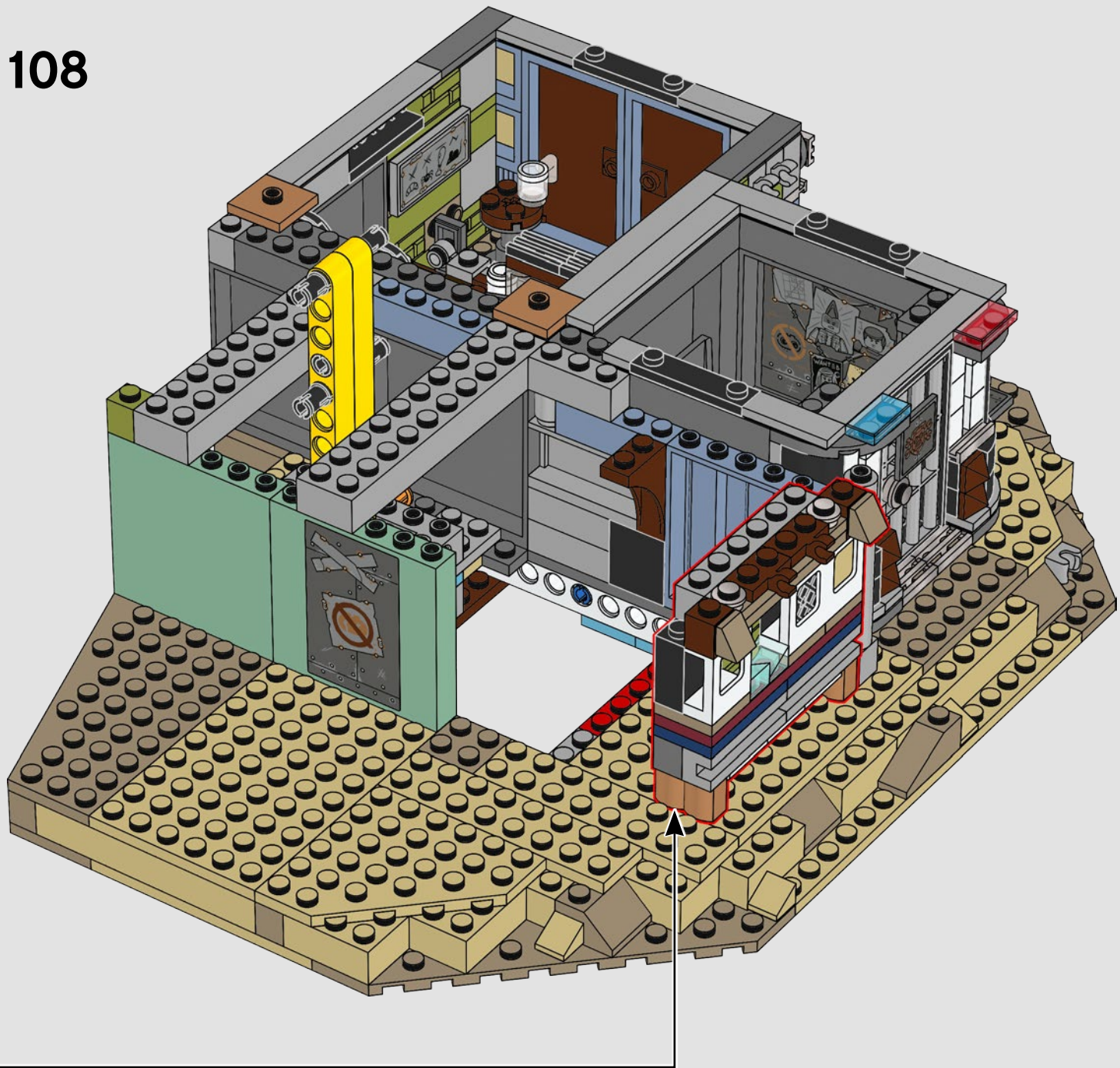

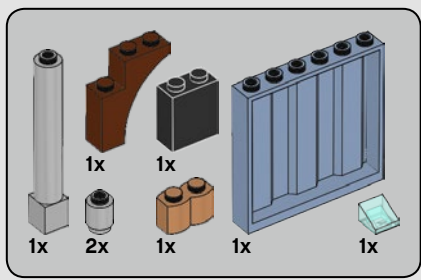

109

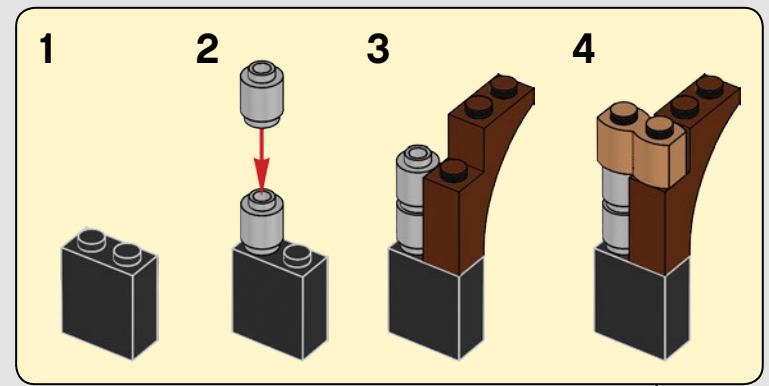
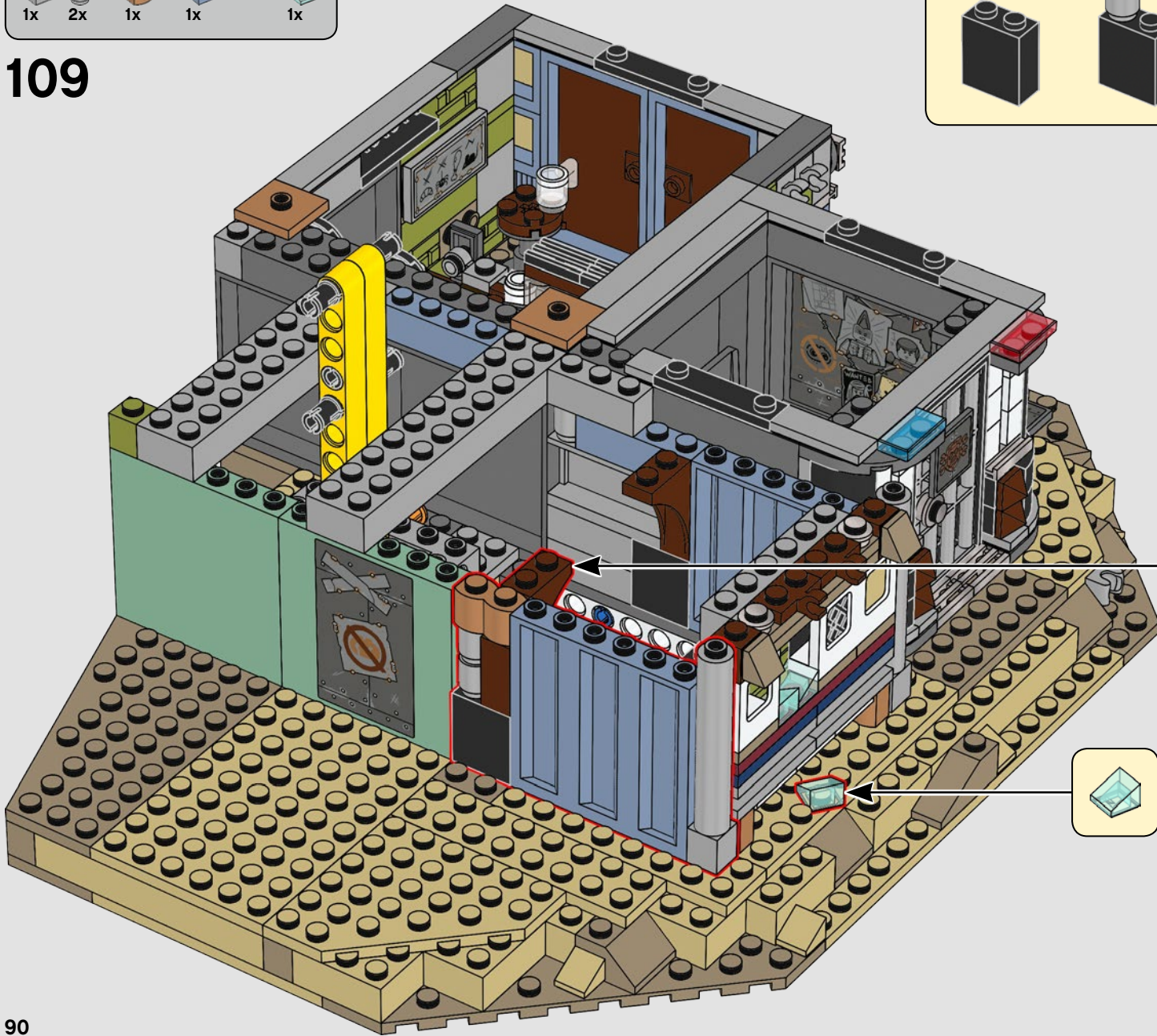

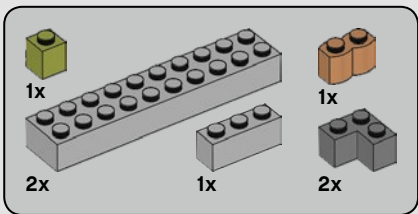

110

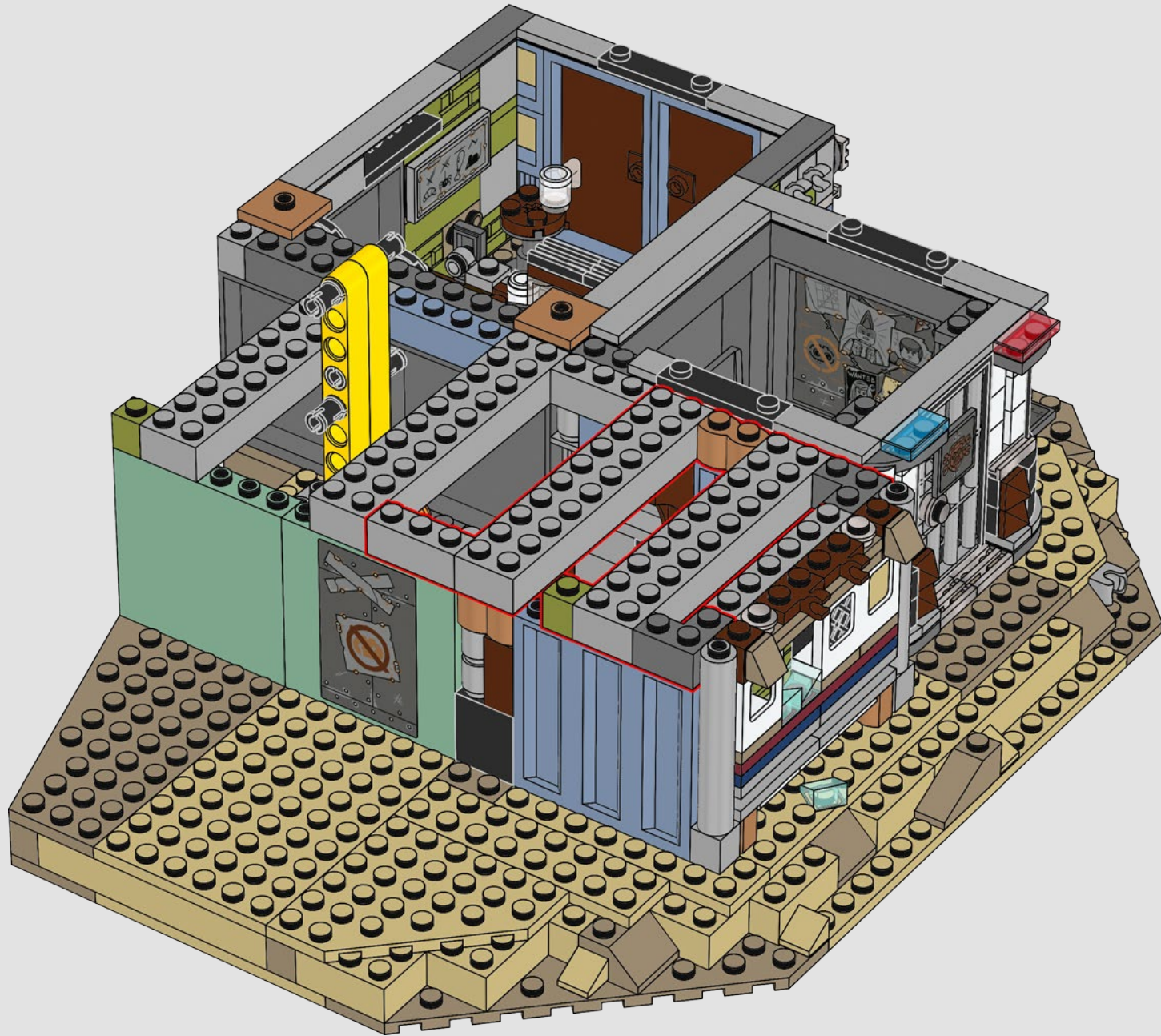

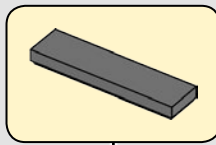
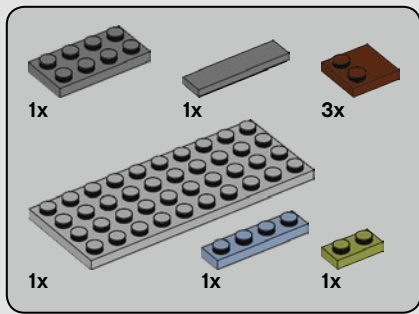

111

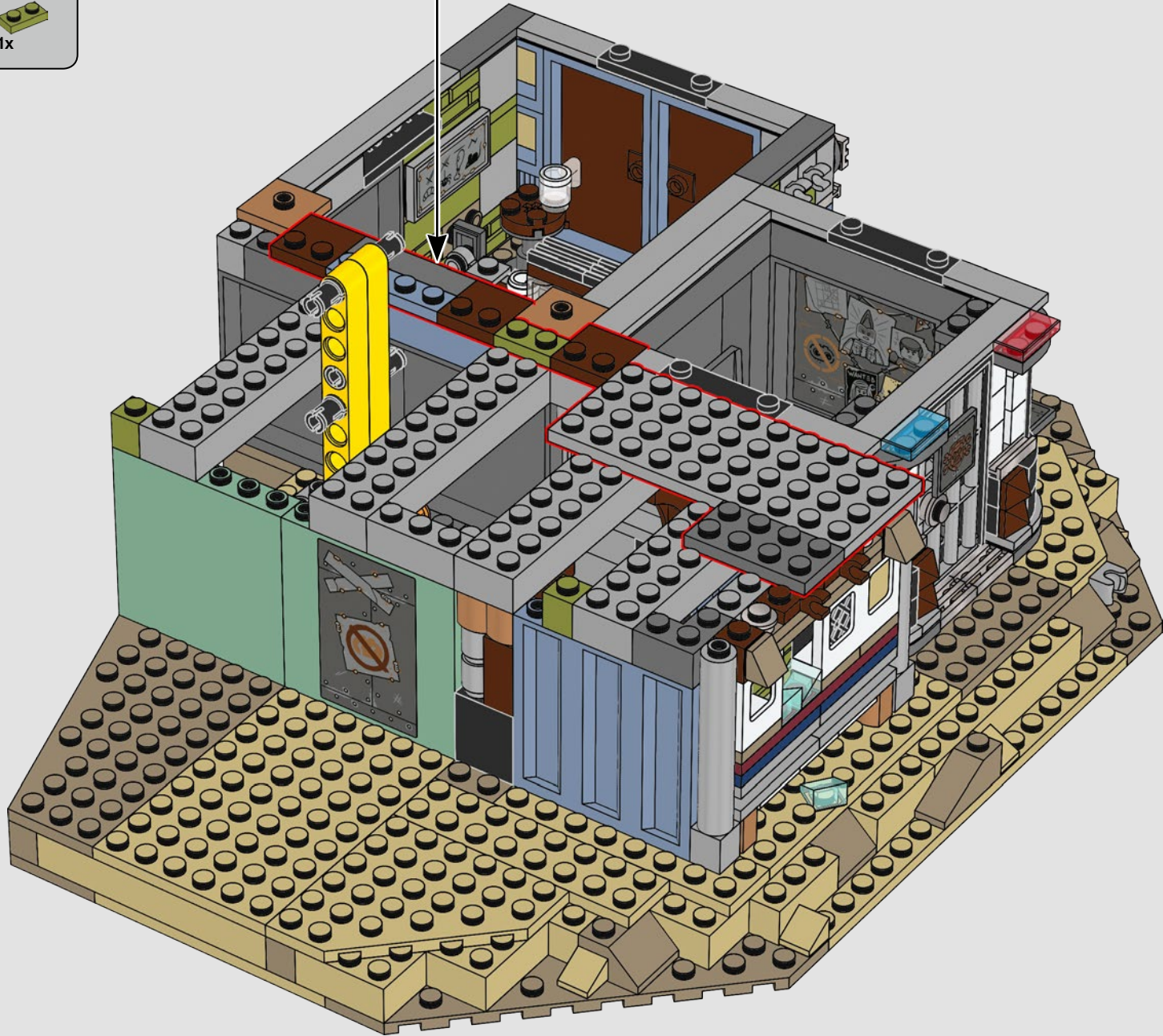

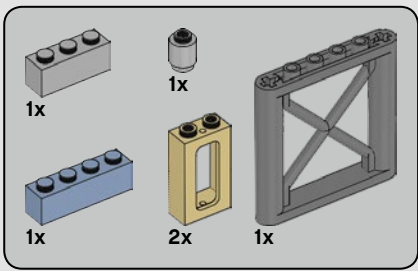

112

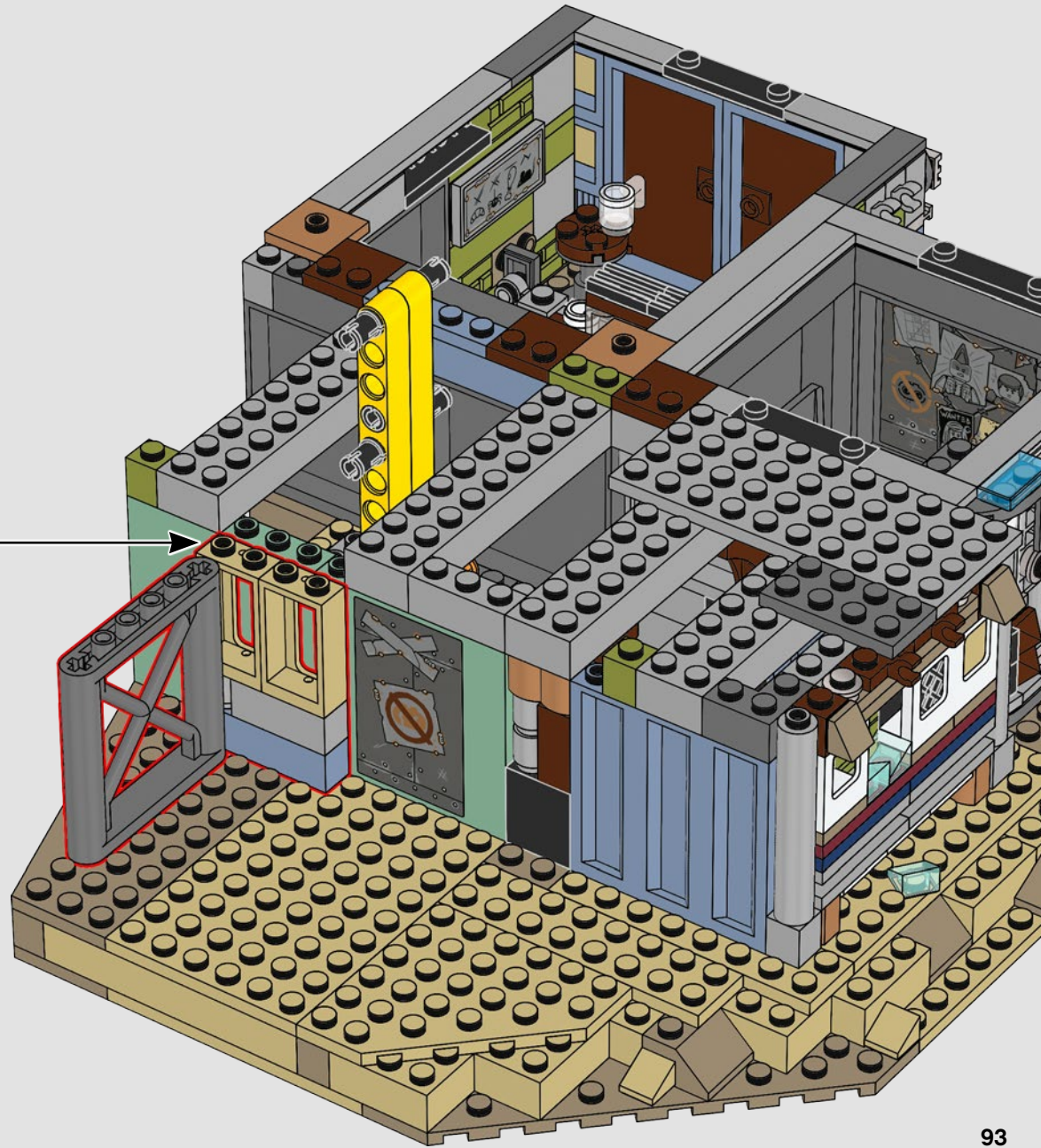
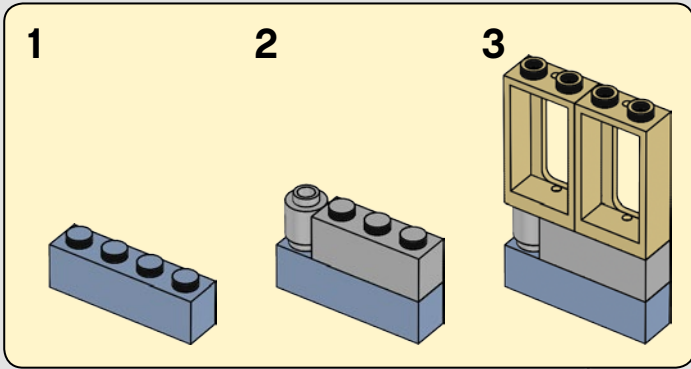

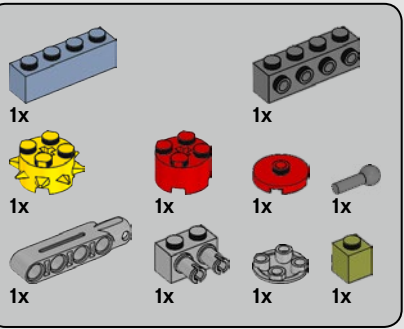

113

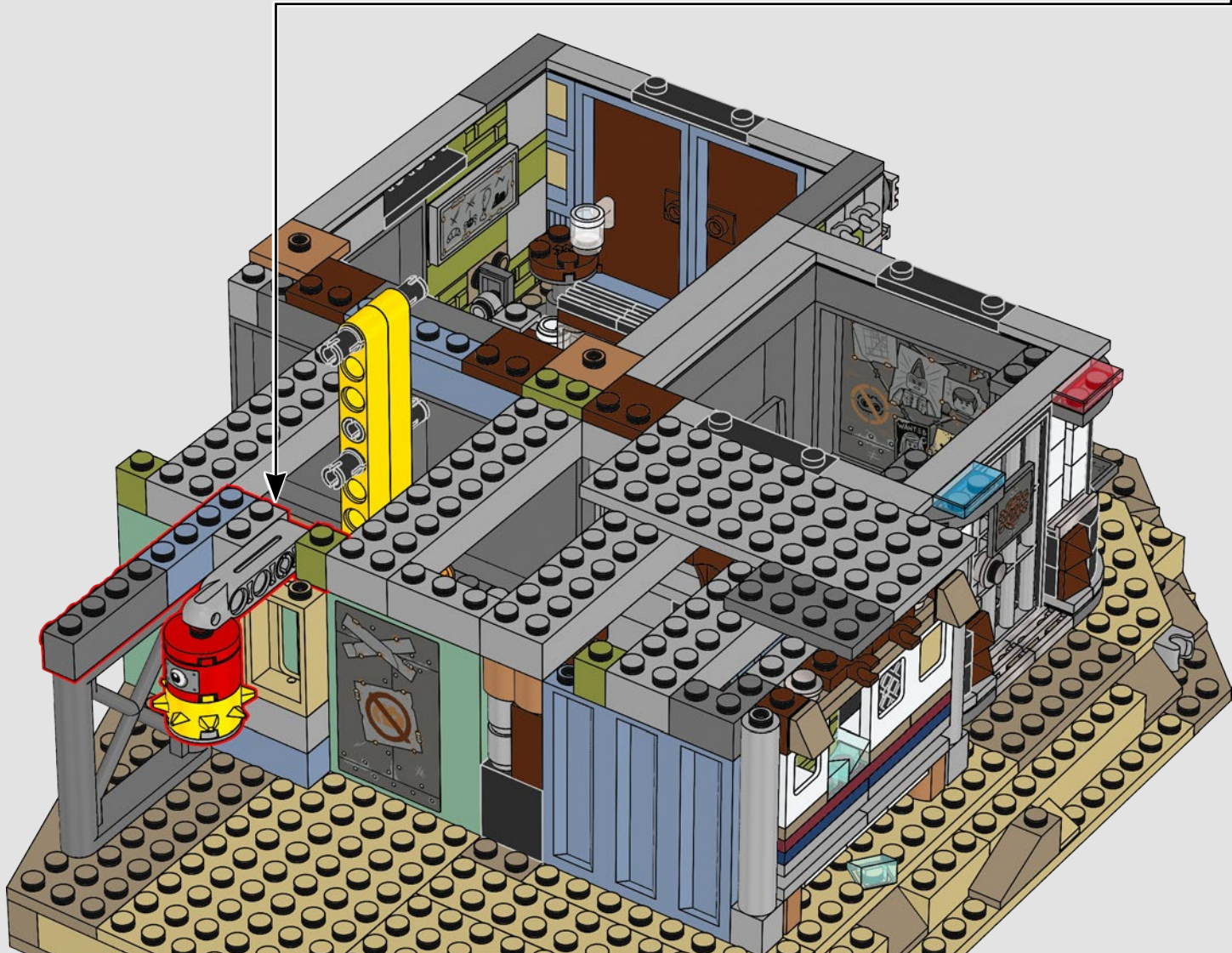
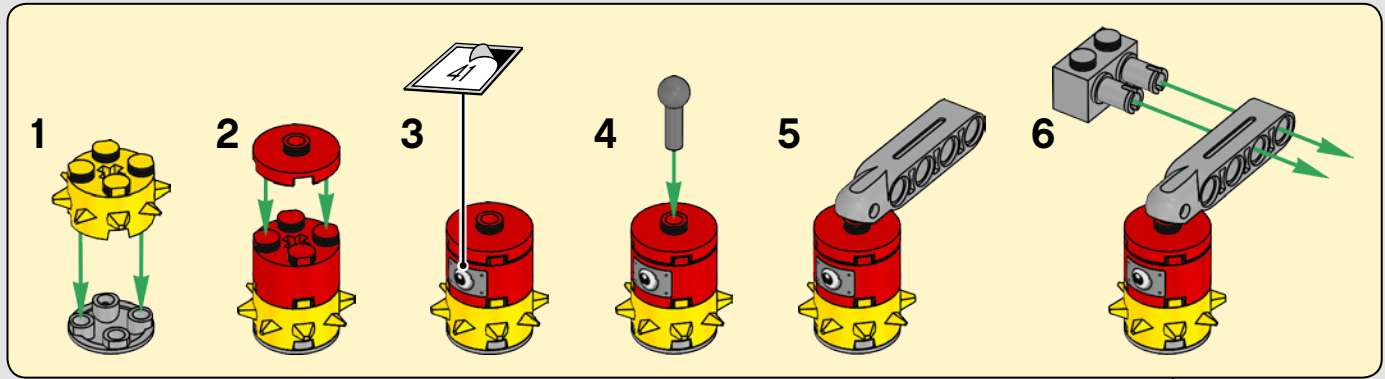

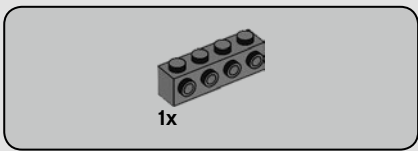

114

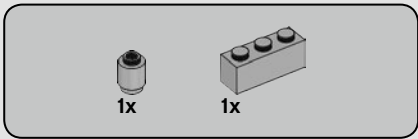
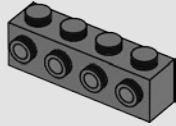

115

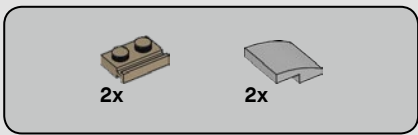
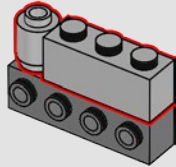

116

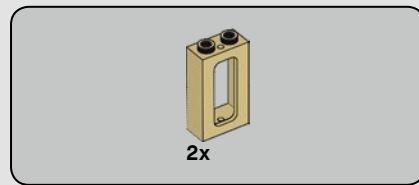
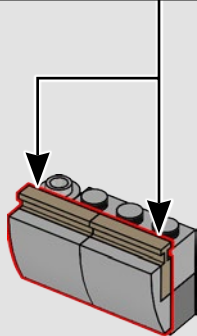
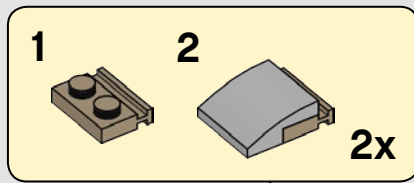

117

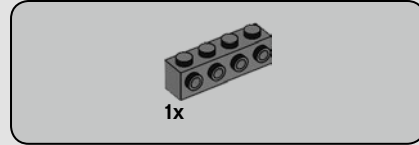
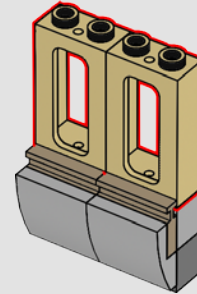

118

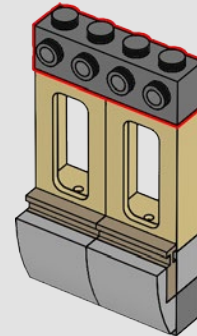

119





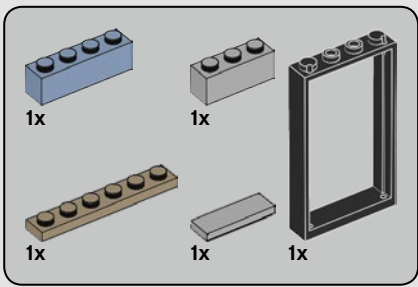

120



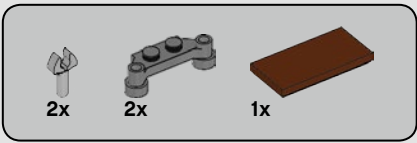



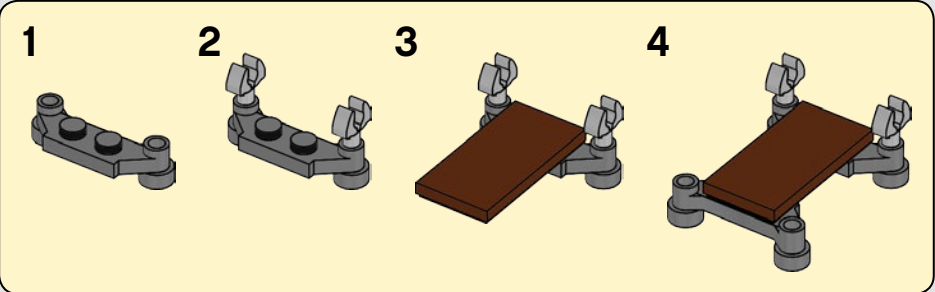

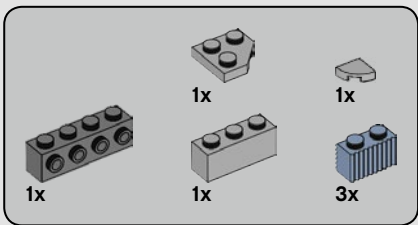
121



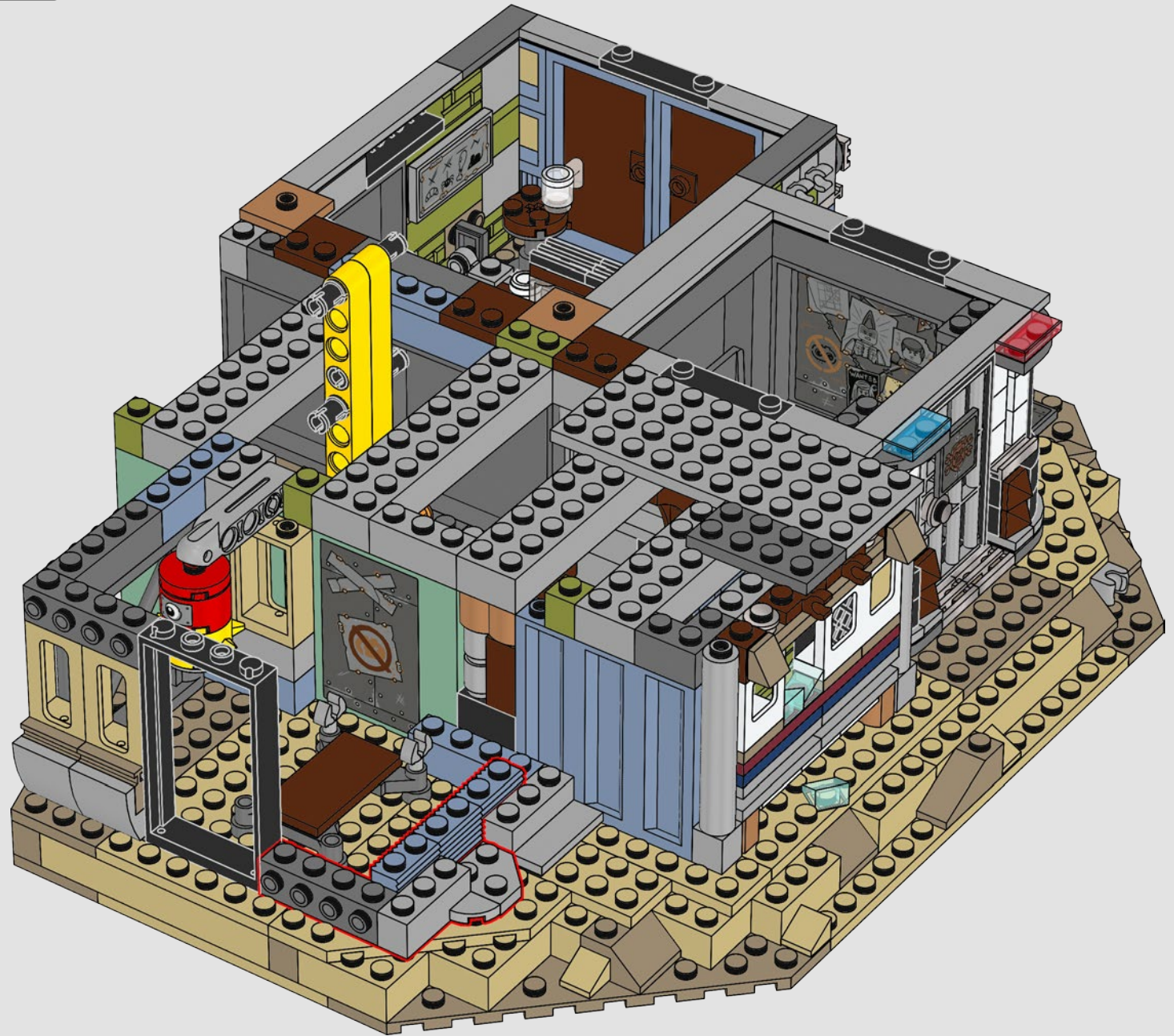

122



2x  2x  2x 

123



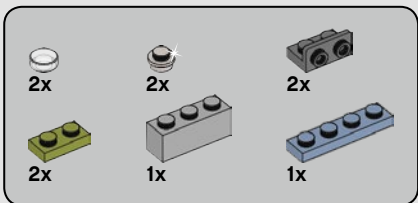

# 124

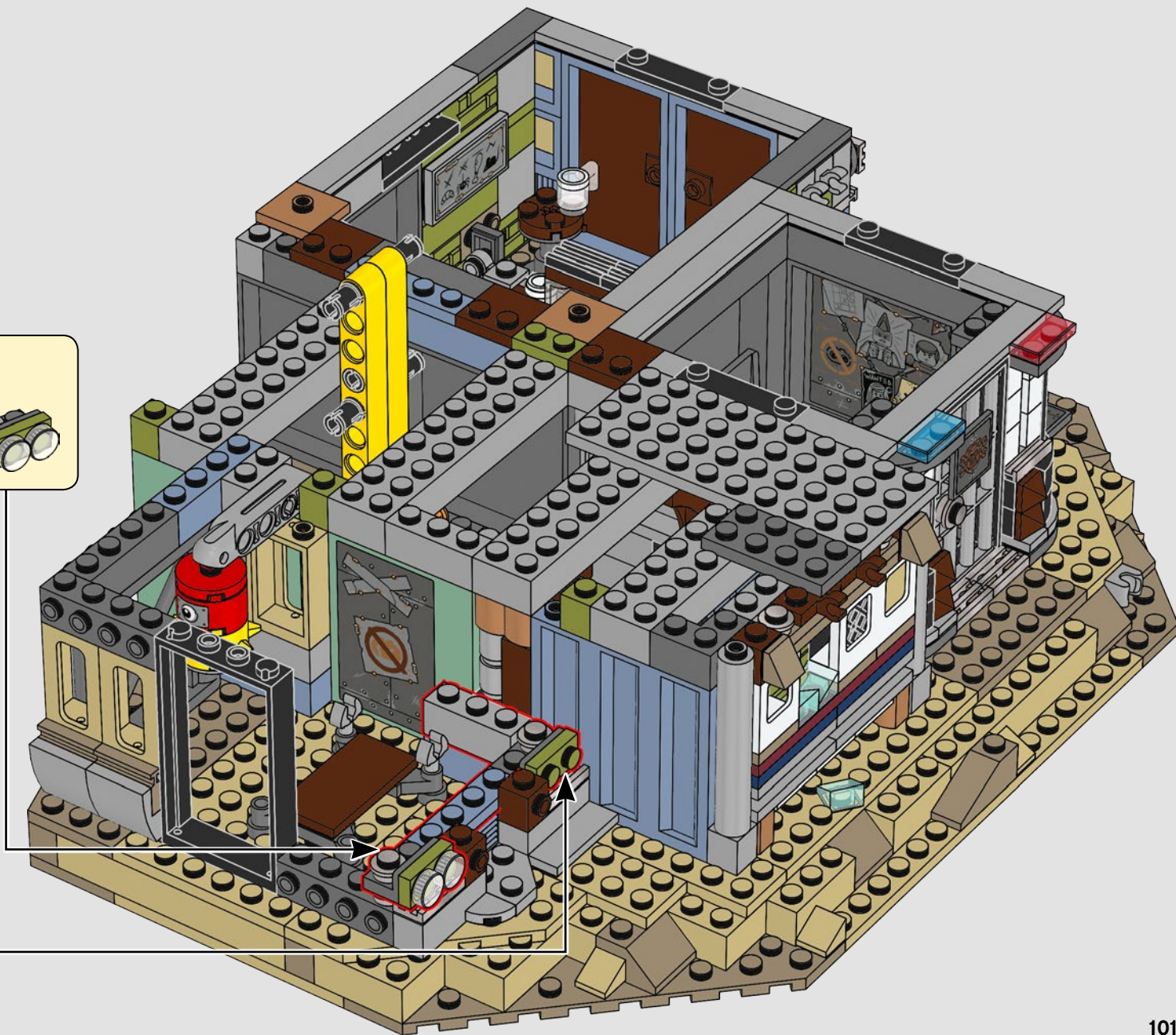
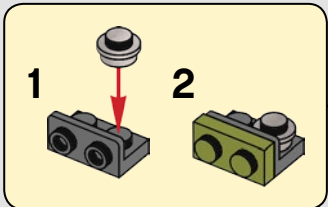
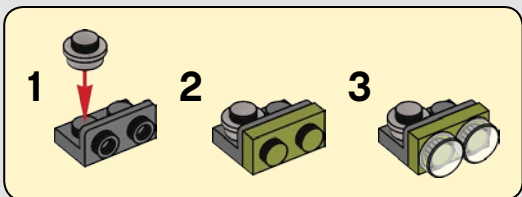

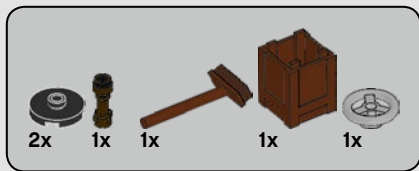

125



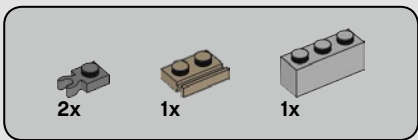

126

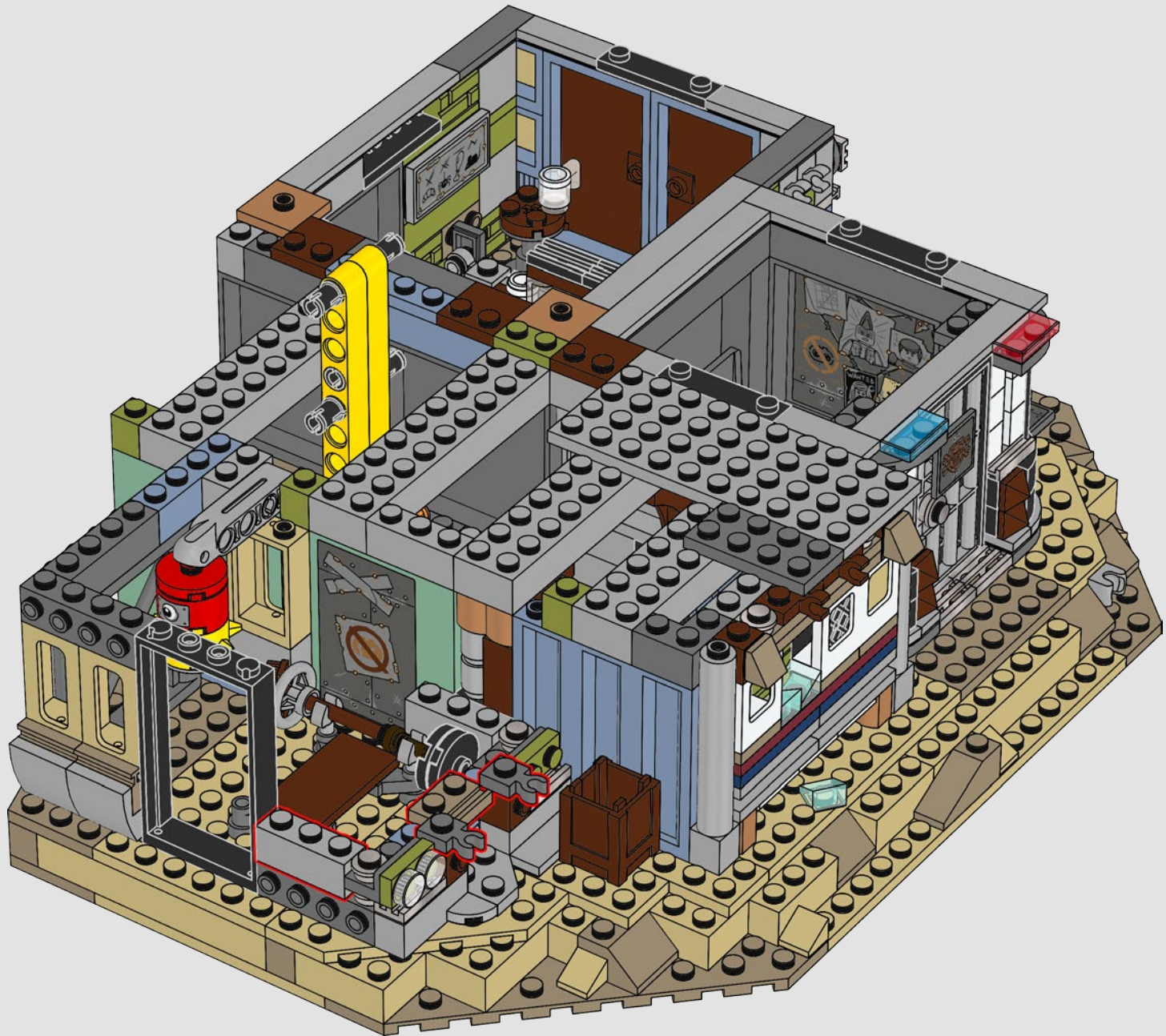

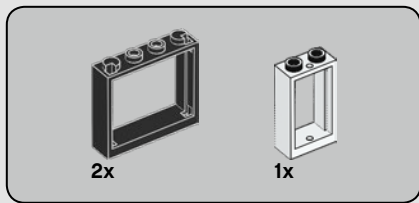

127

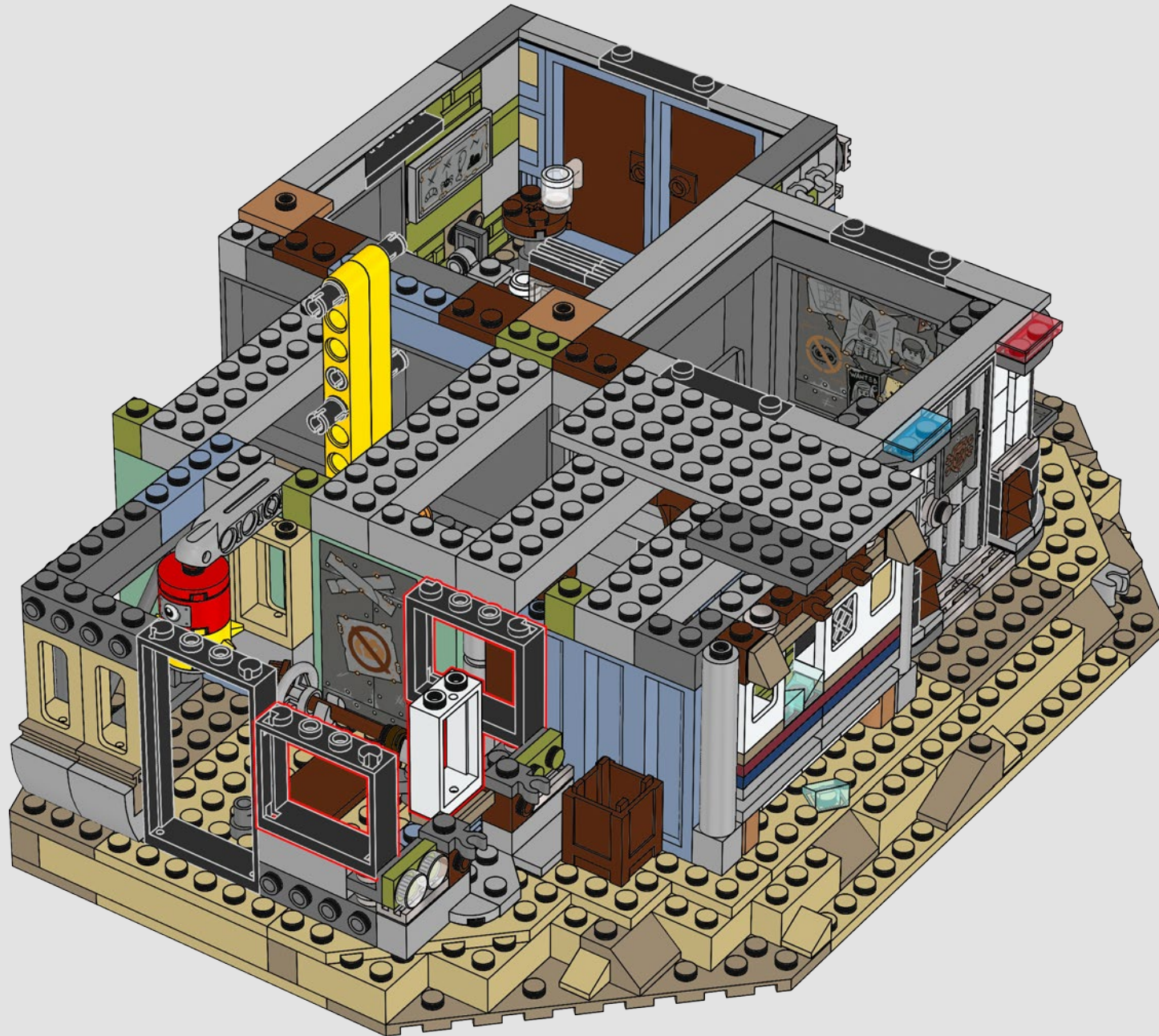



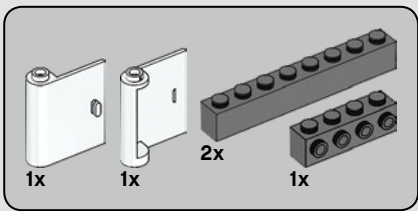

128

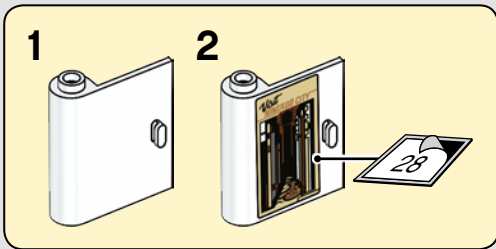
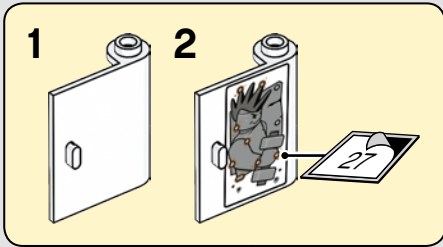

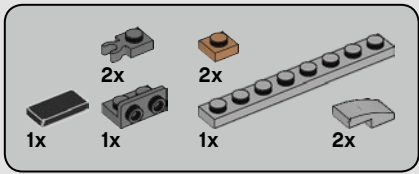

129

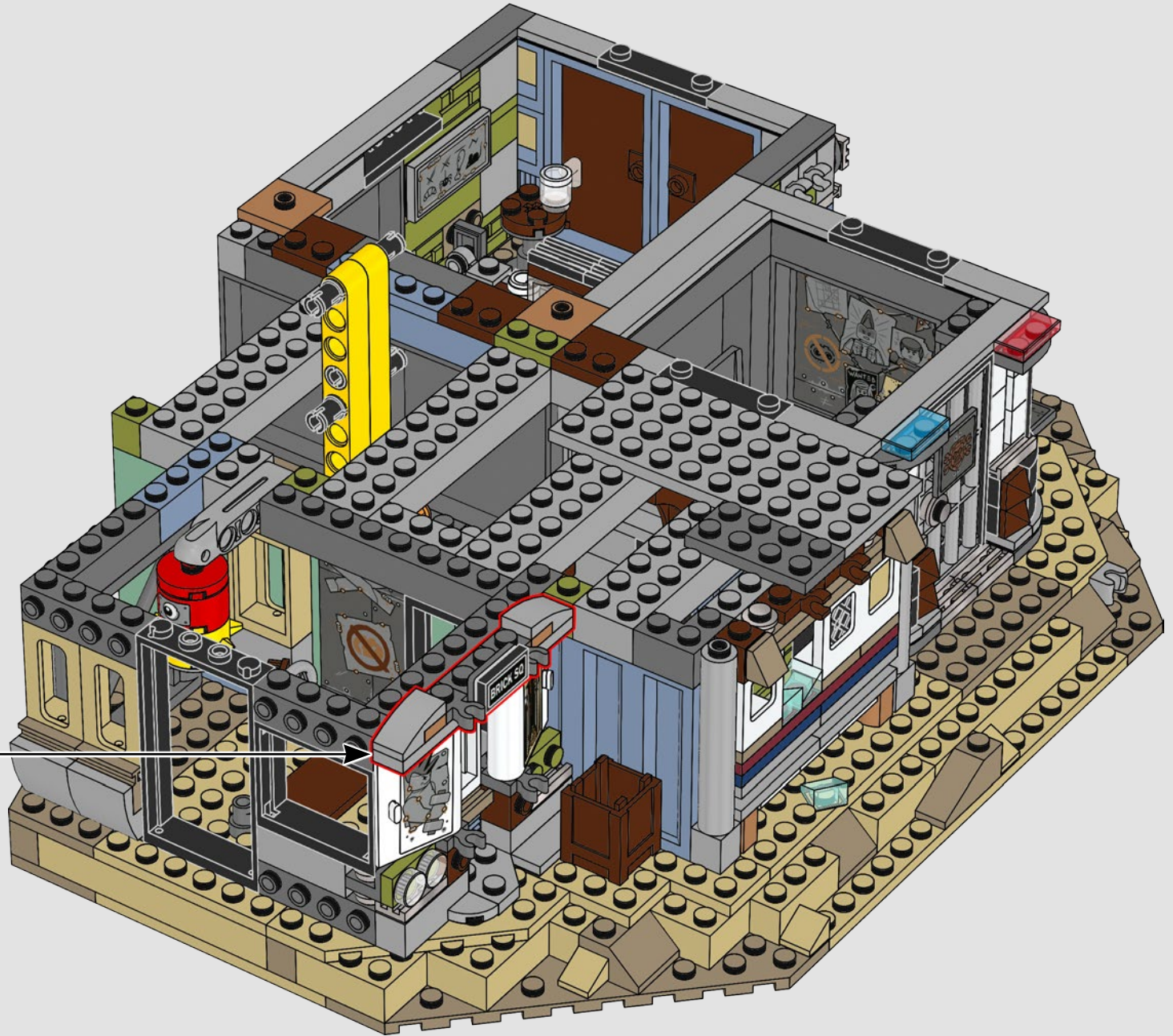
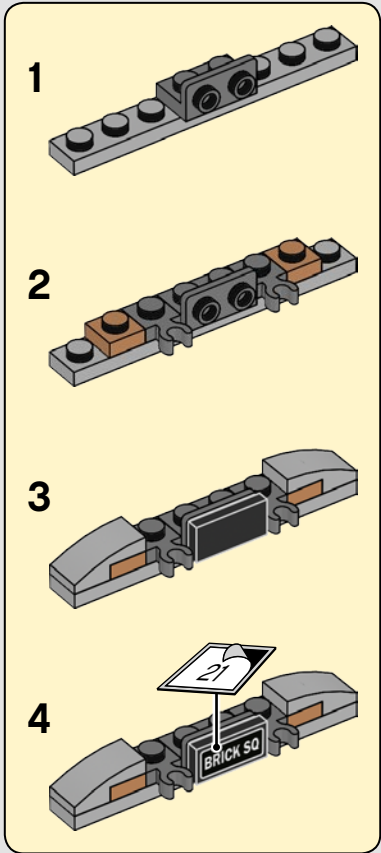

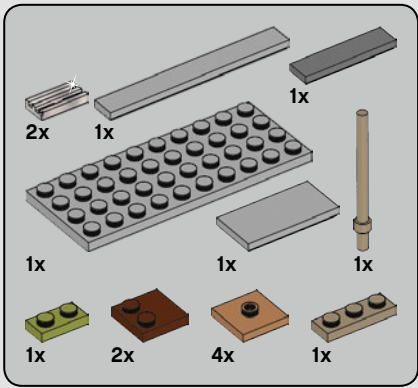

130

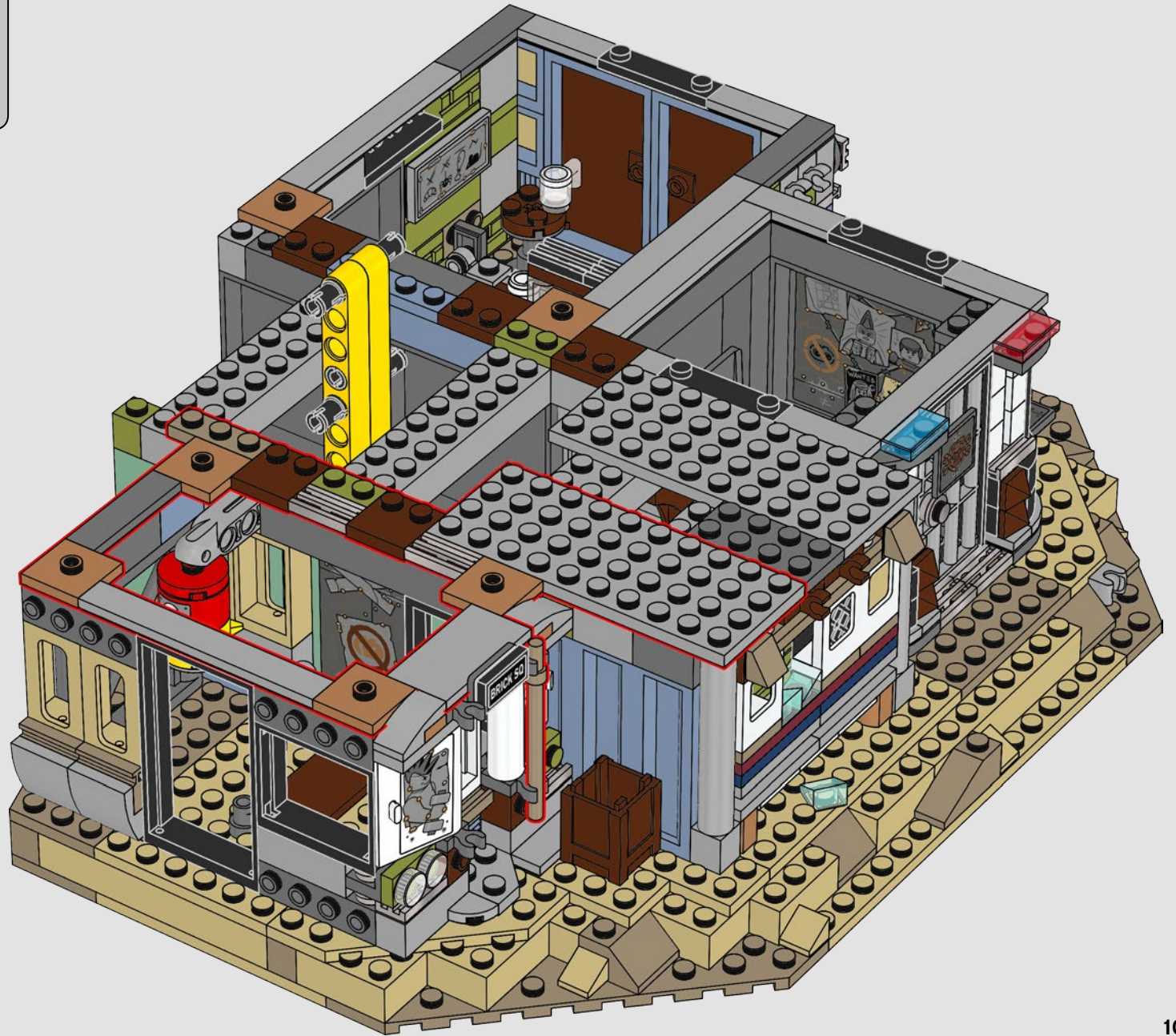

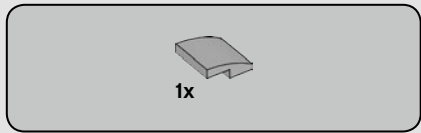

131

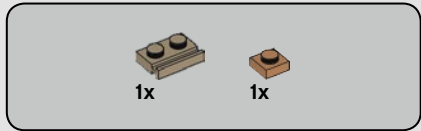
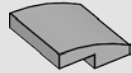

132

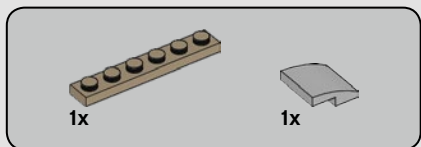
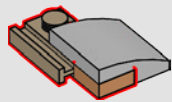

133

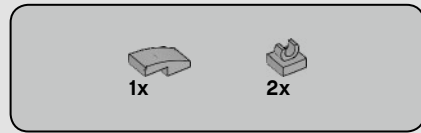
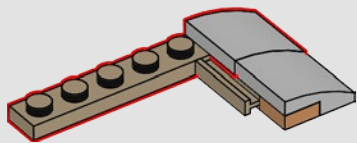

134

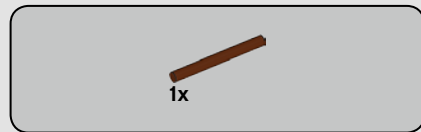
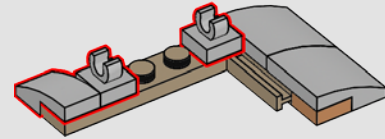

135

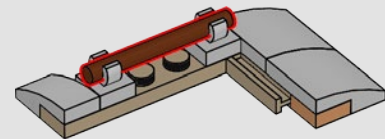

136



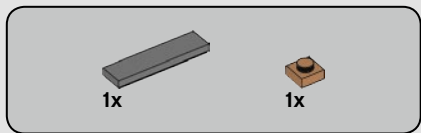

137

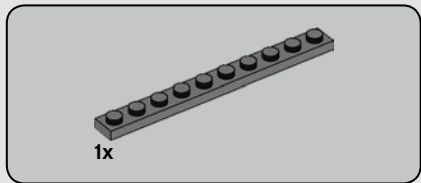
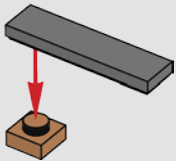

138

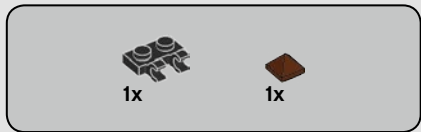
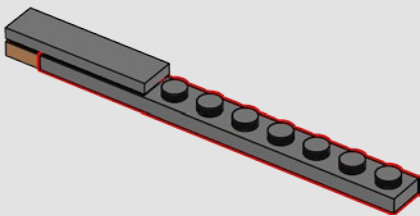

139

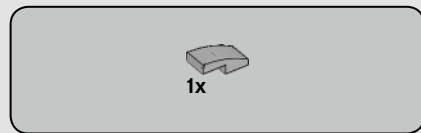
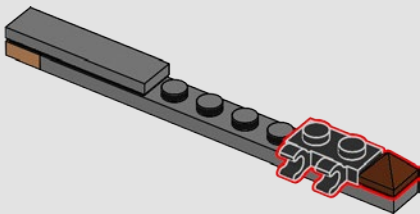

140

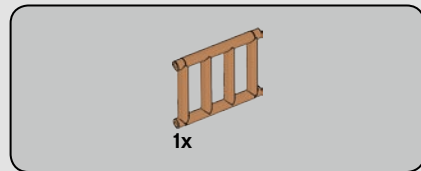
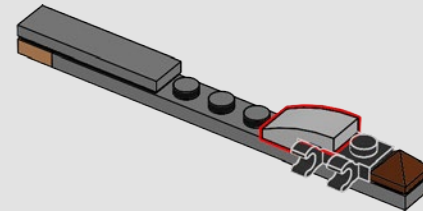

141

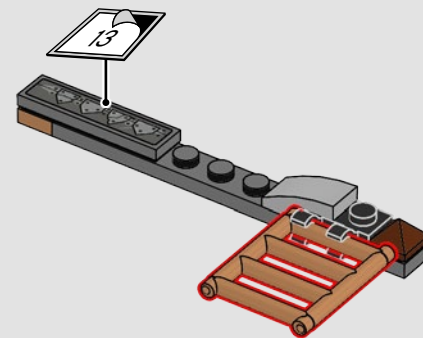

142

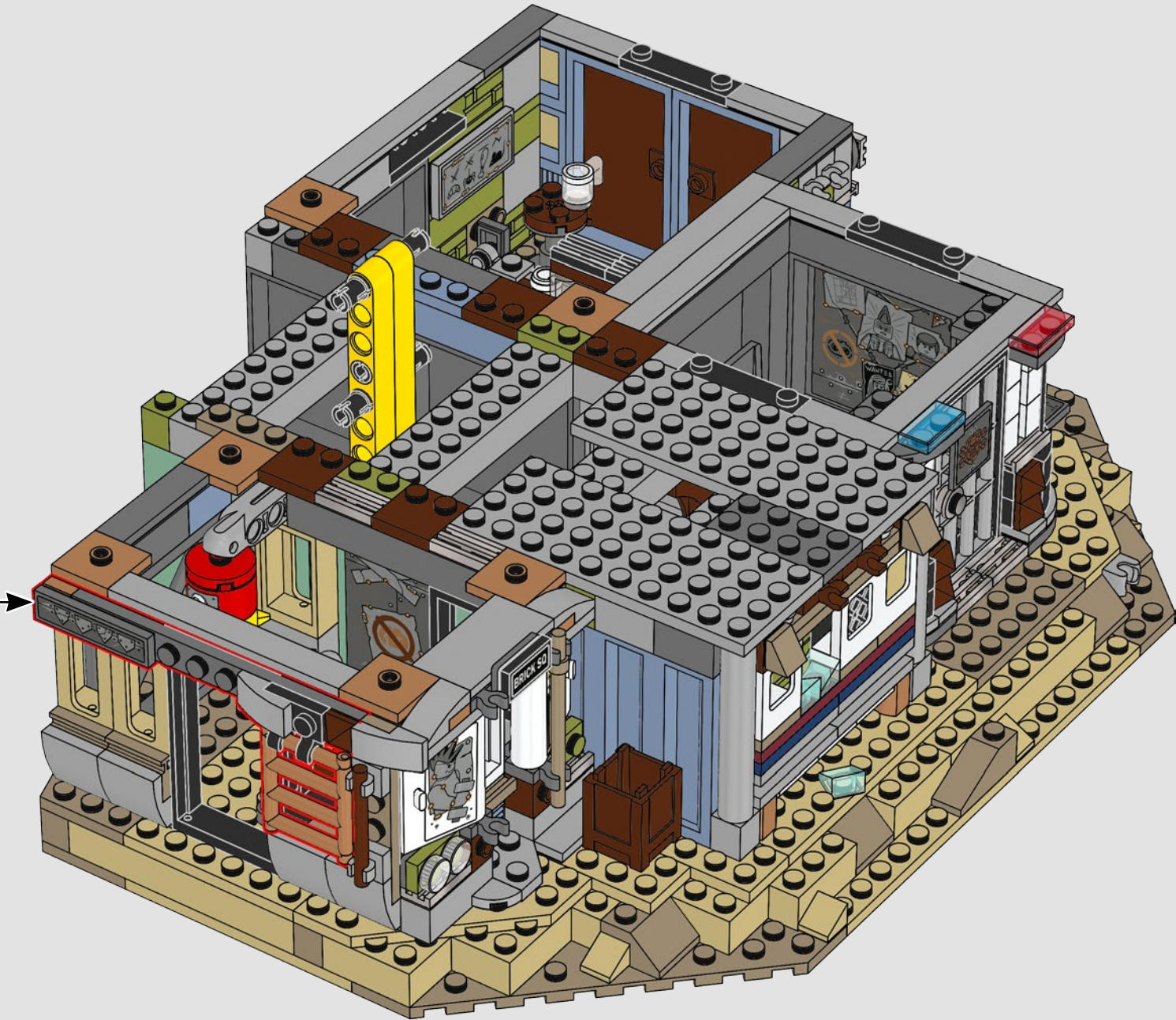

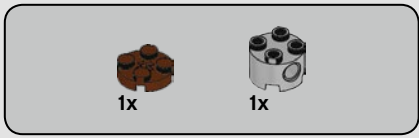

143

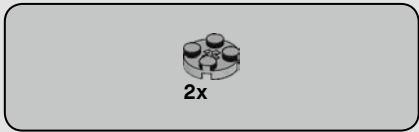
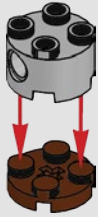

144

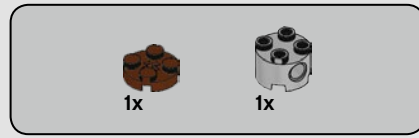

145

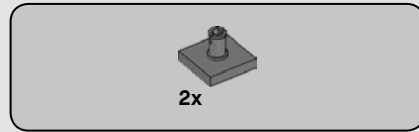

146

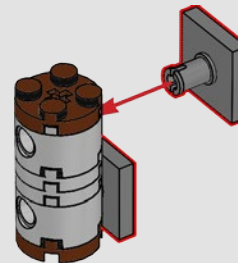





147

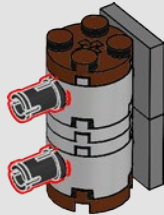

148

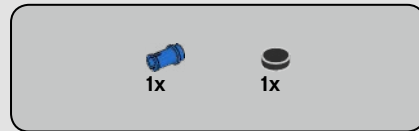
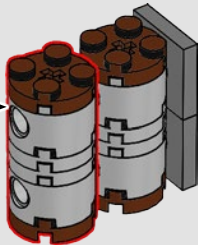
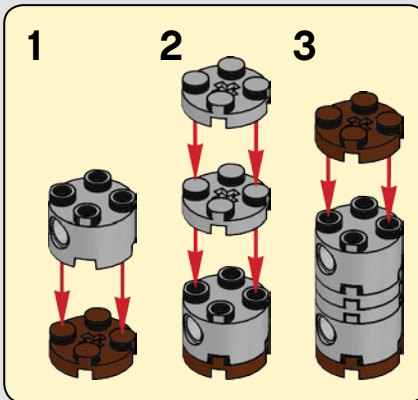

149

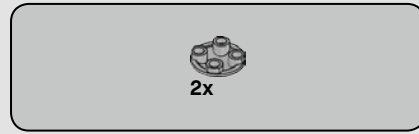
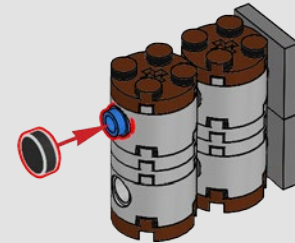

150

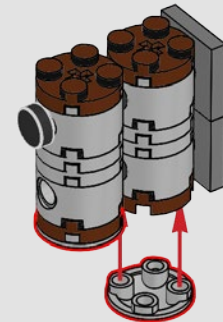

151

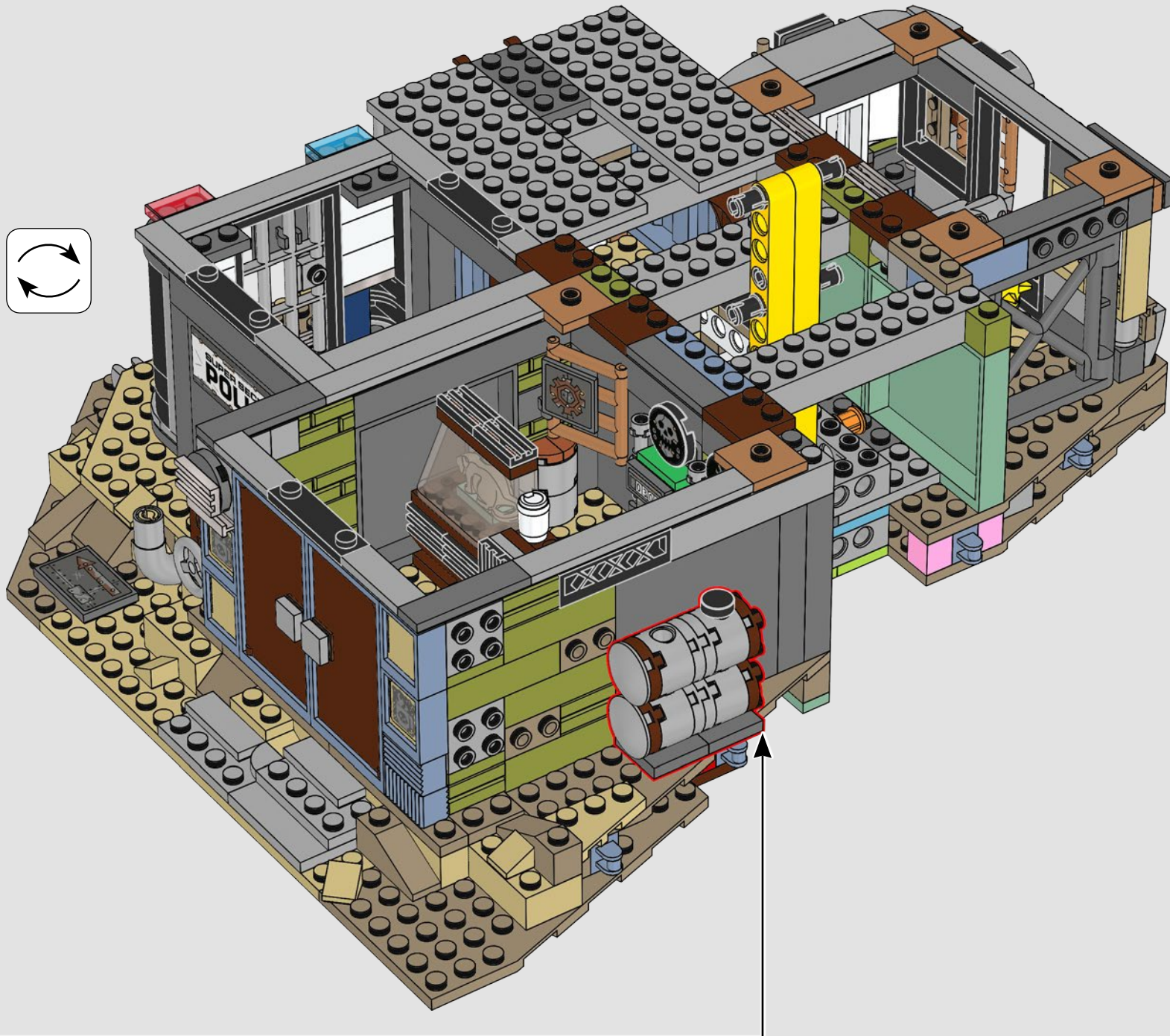
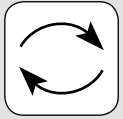

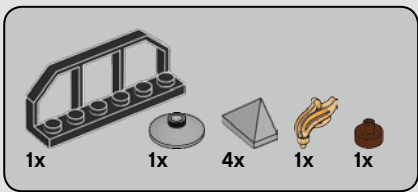

152

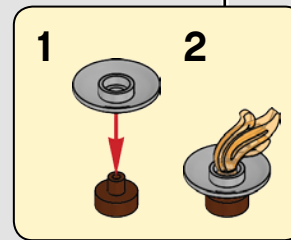
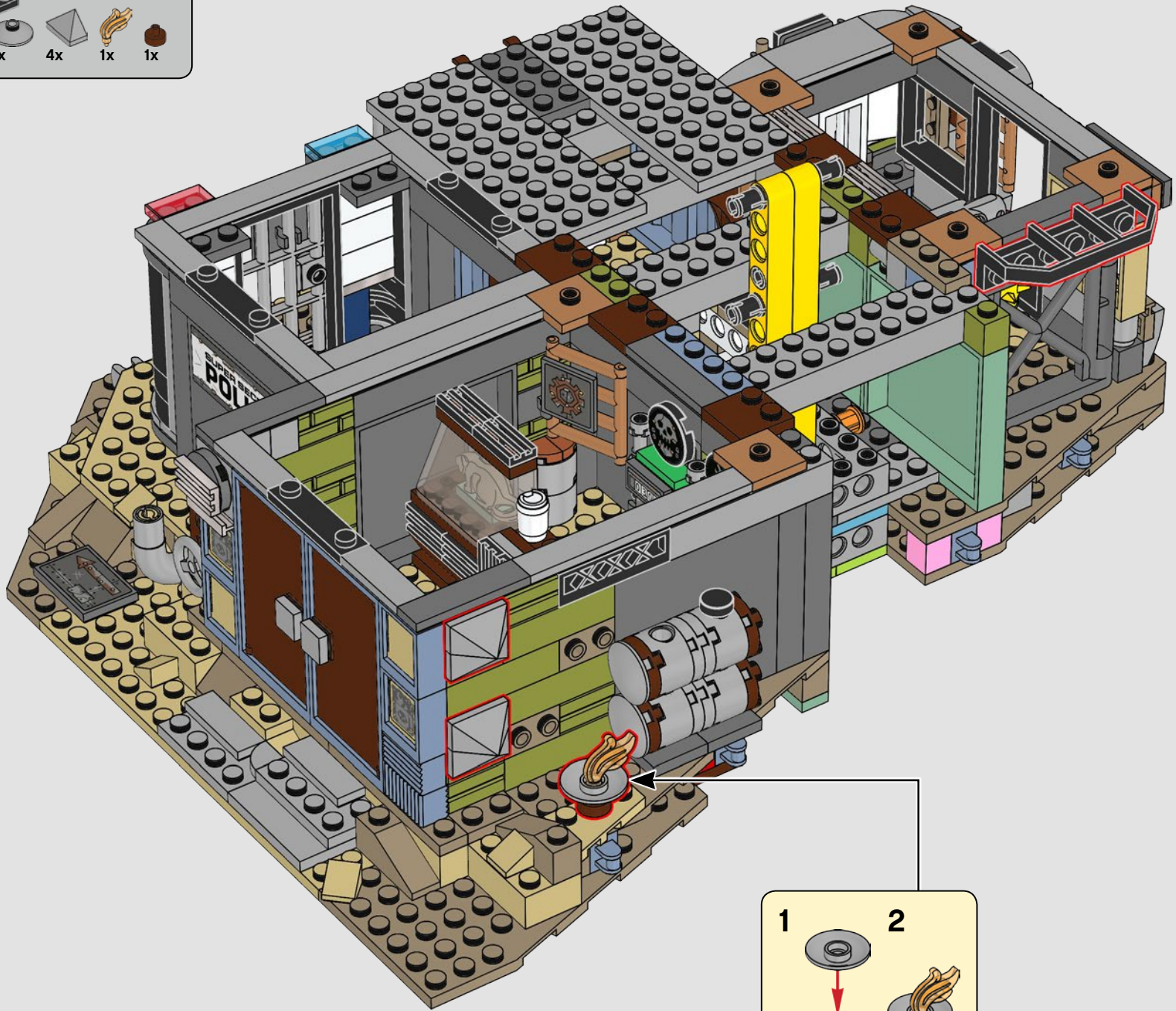

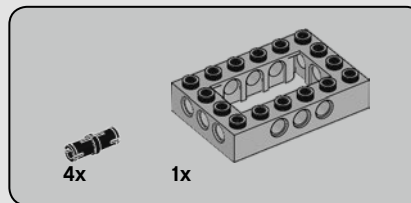
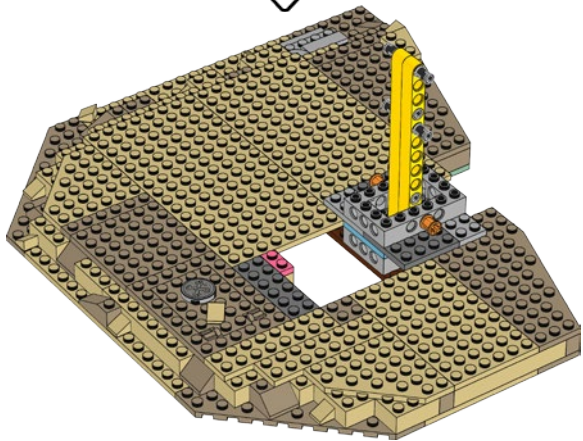
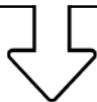

153

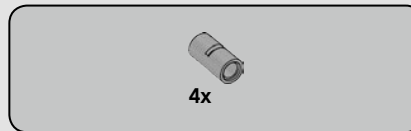
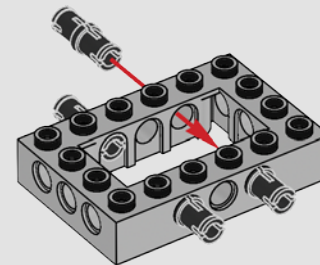

154

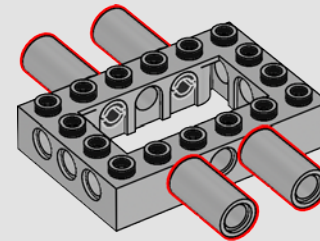

155

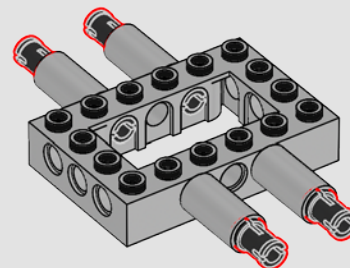

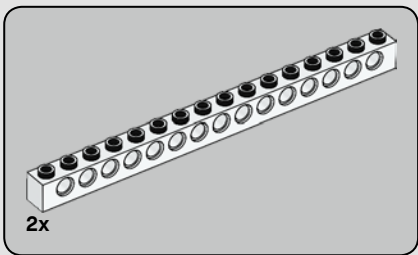

156

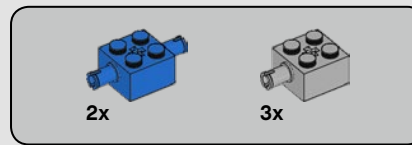
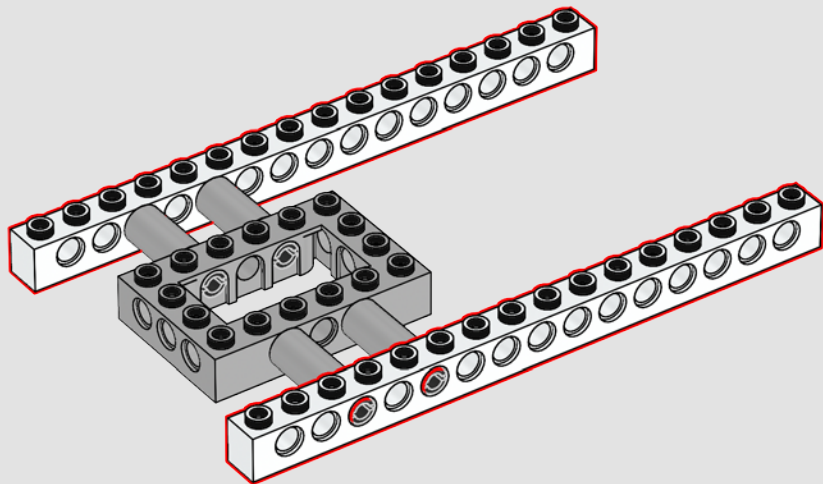

157

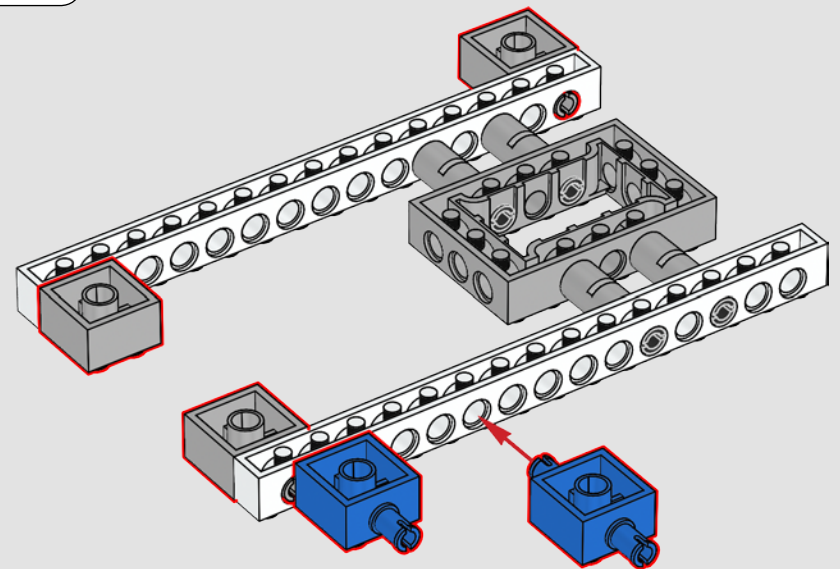
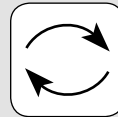

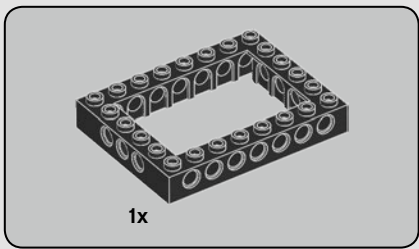

158

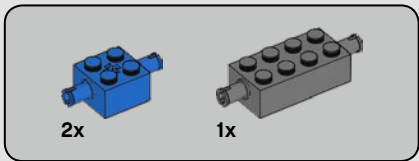
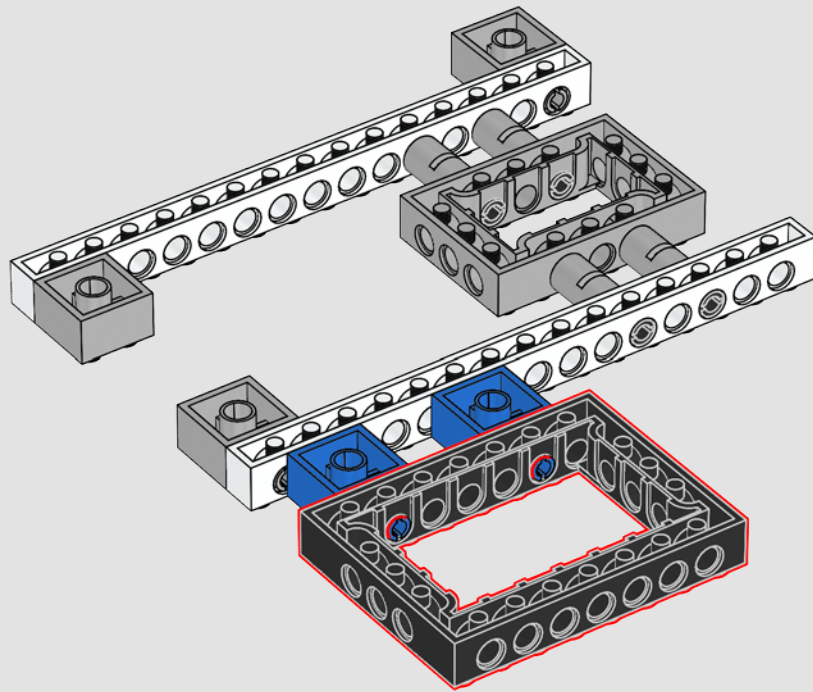

159

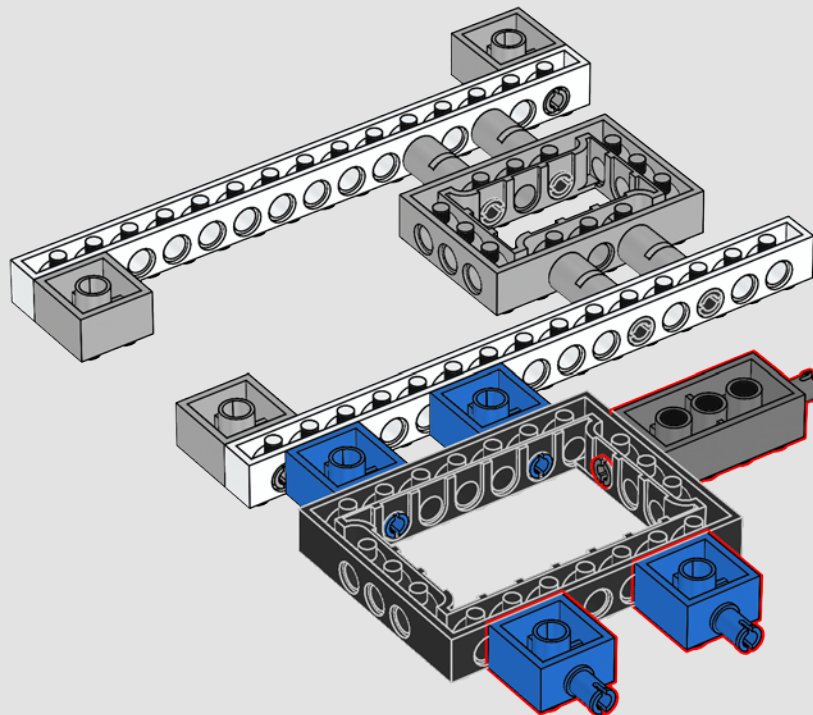

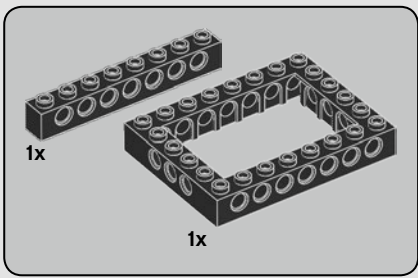

160

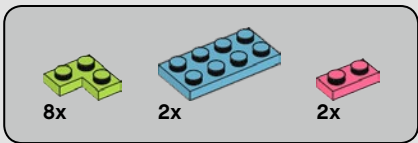
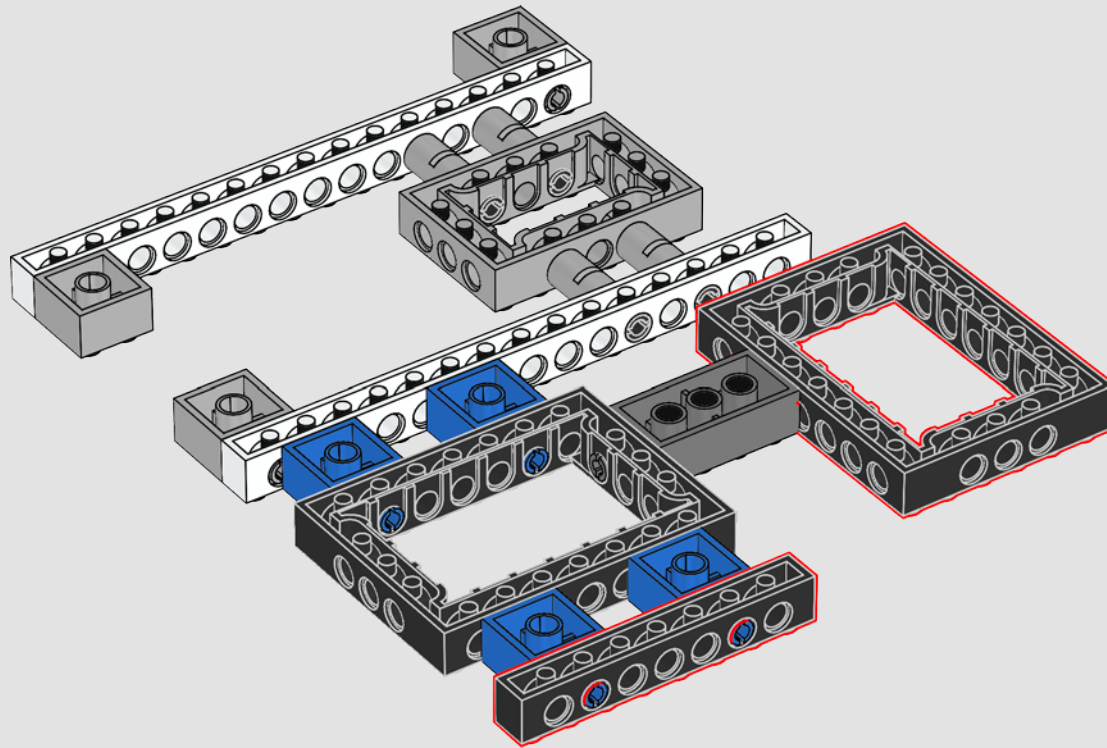

161

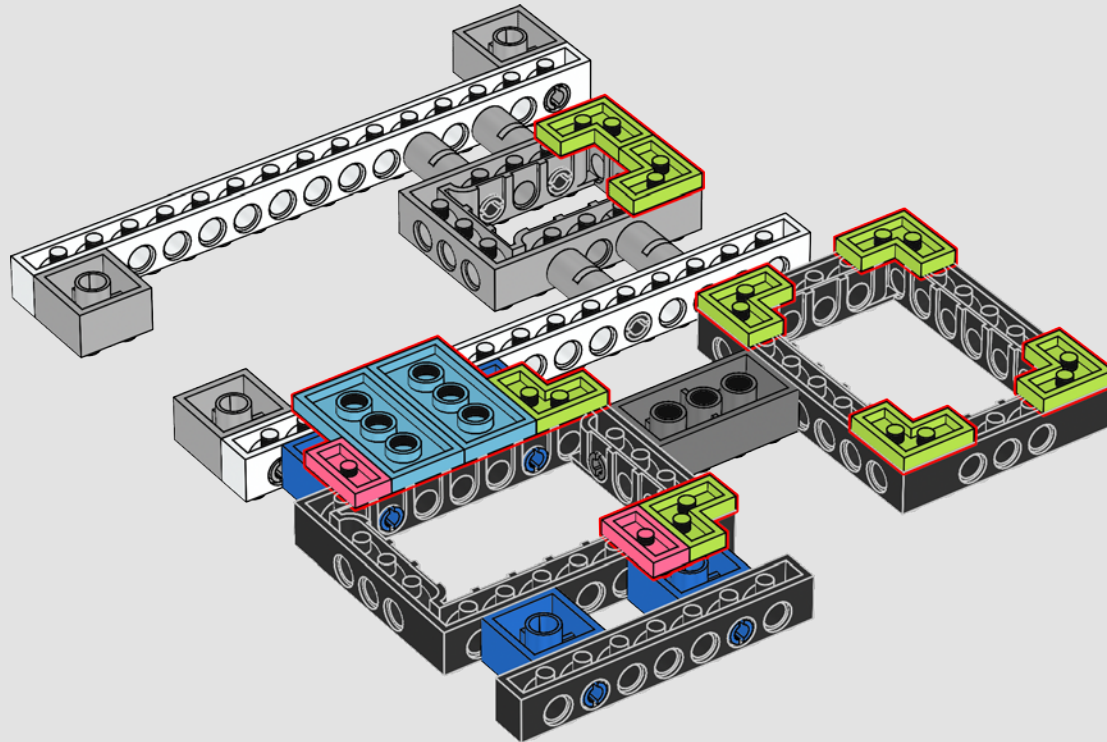

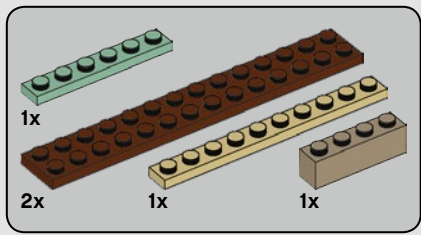

162

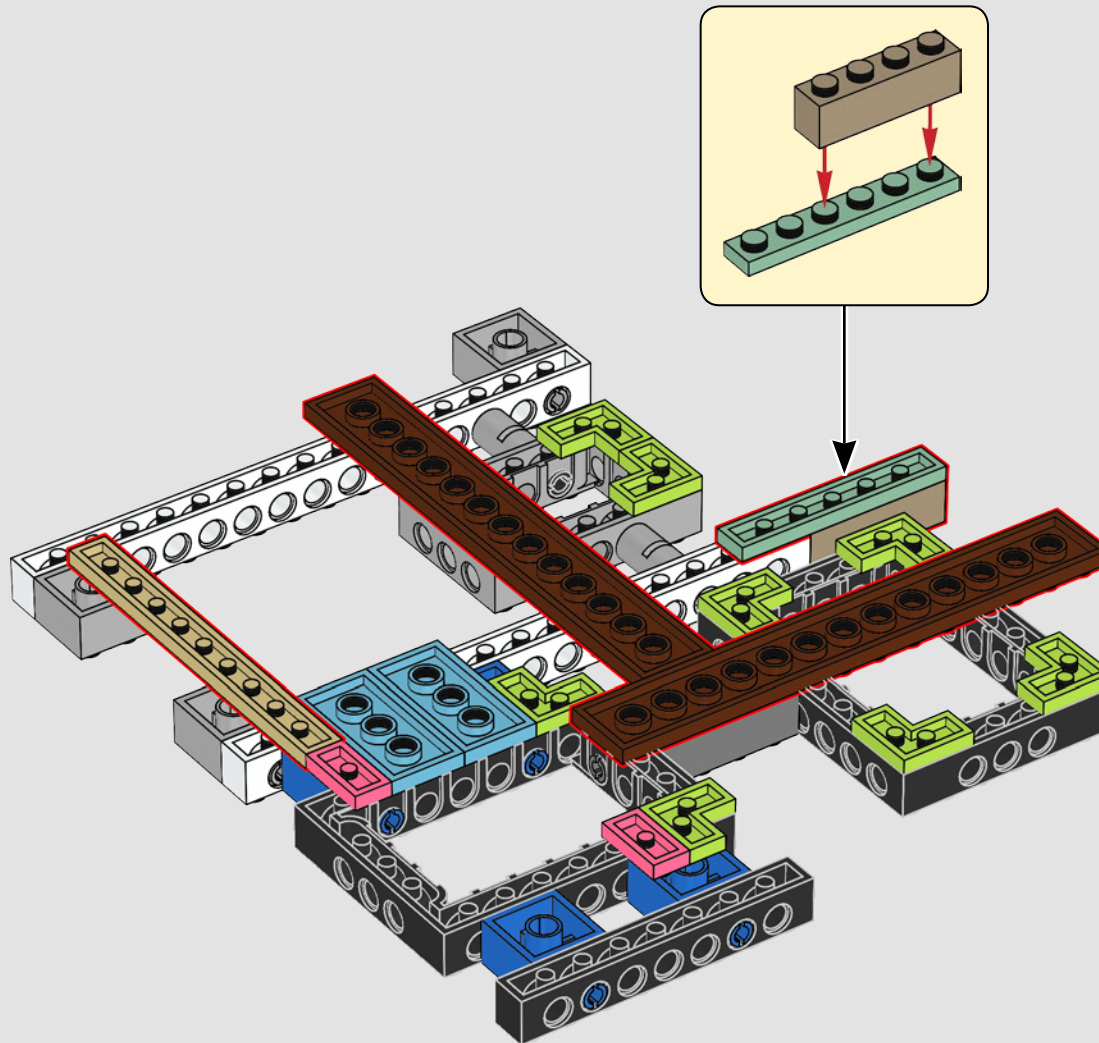



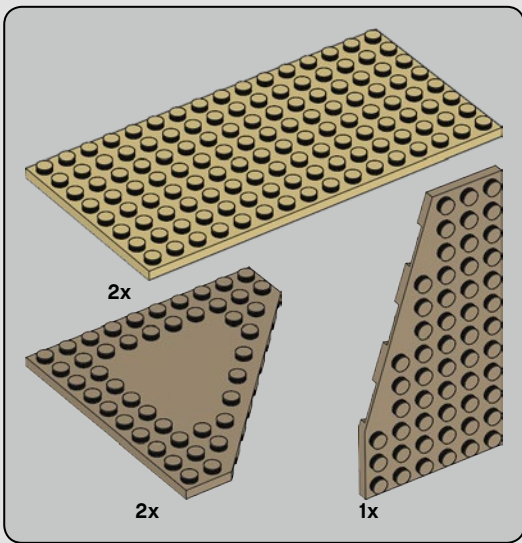

163

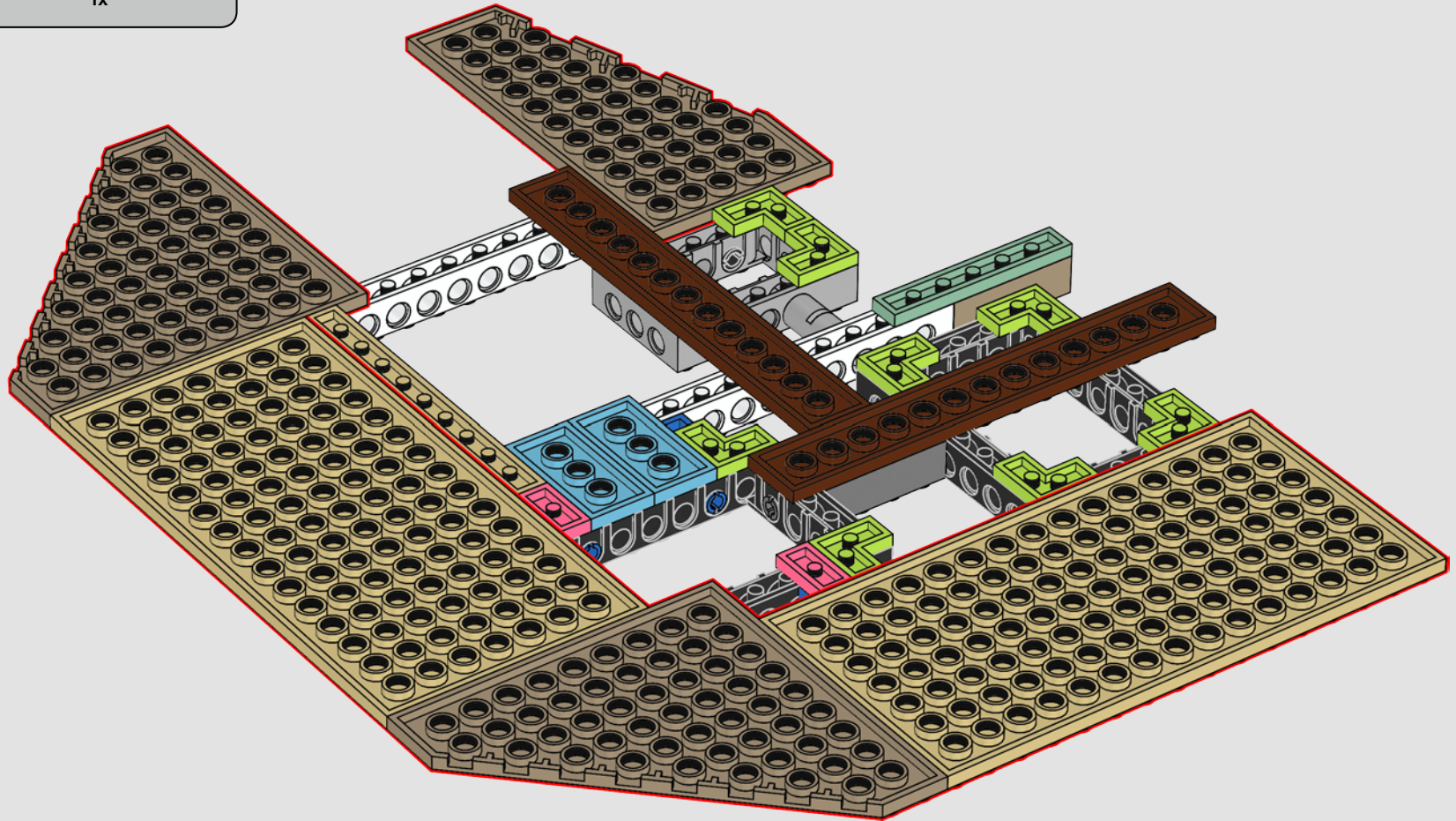

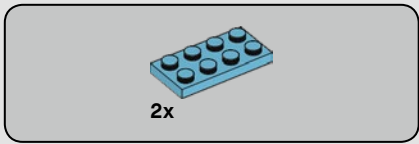

164

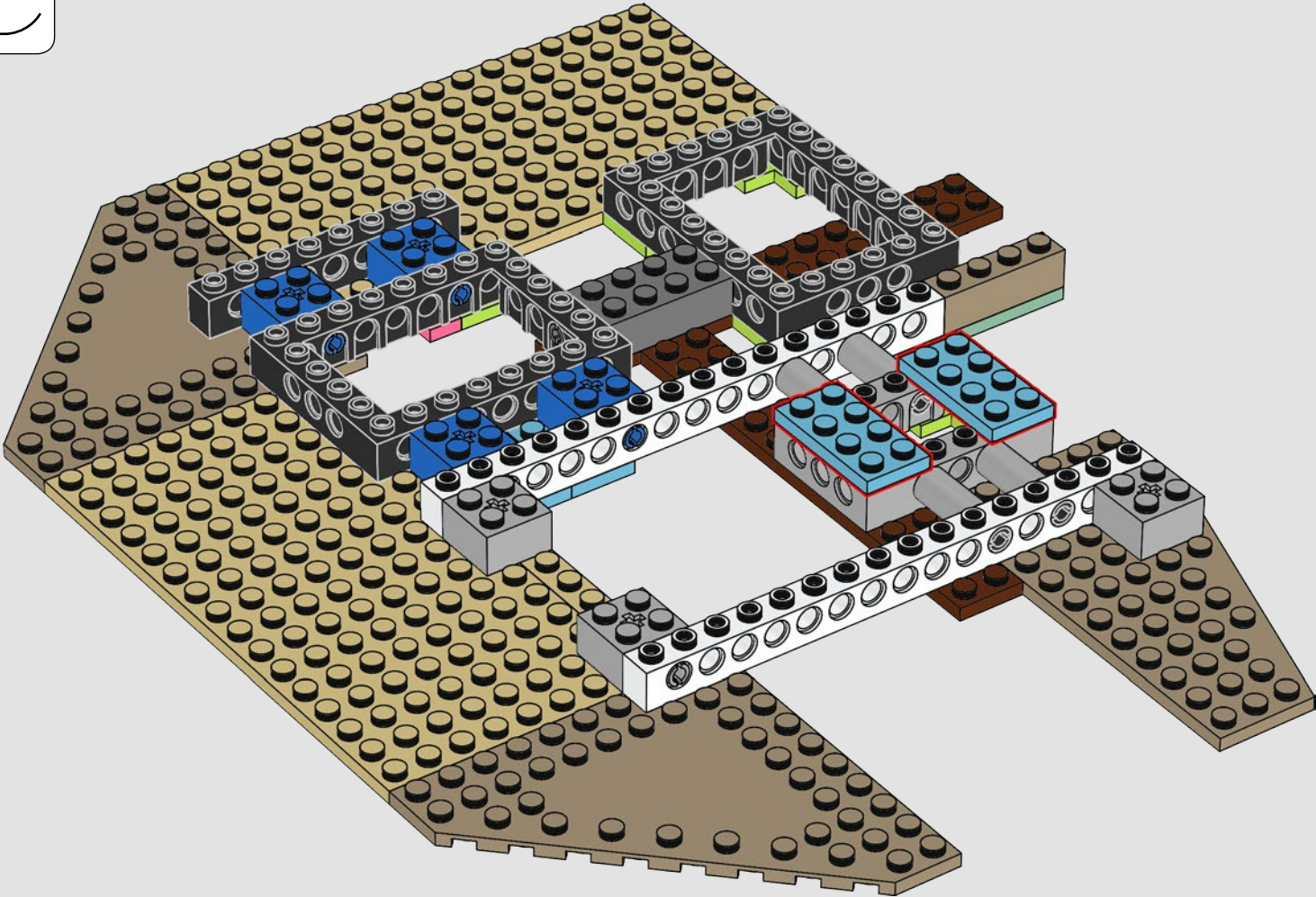
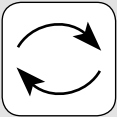

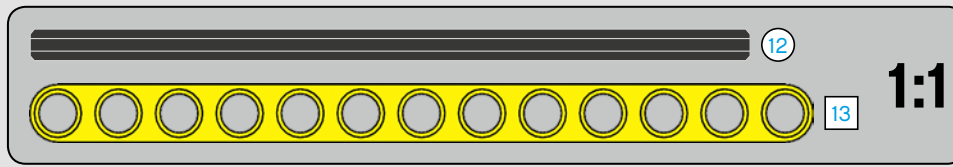
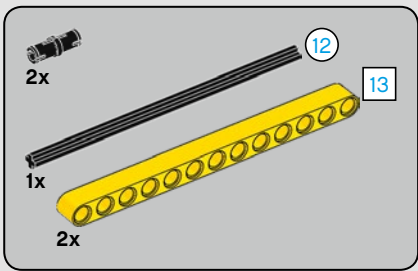

165

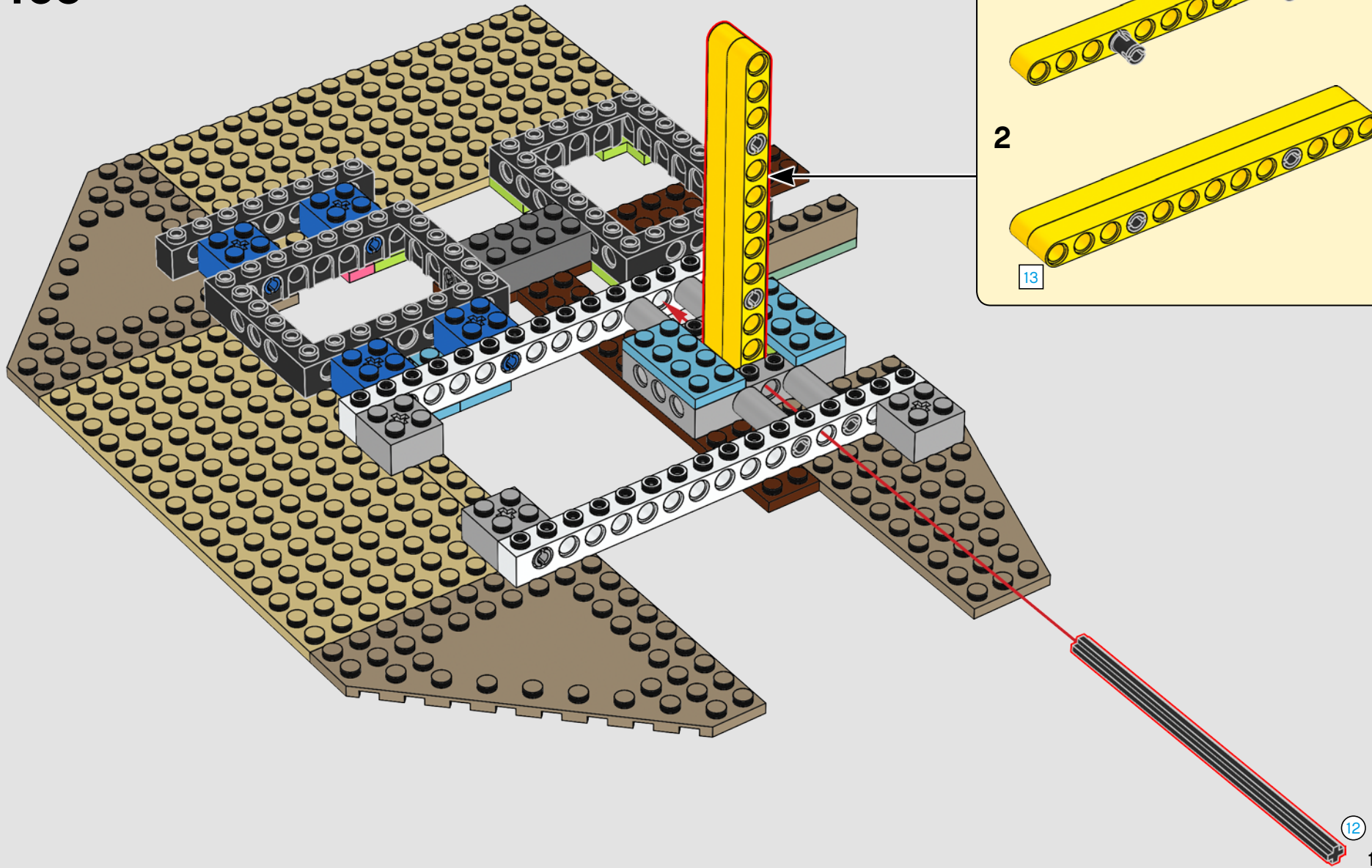
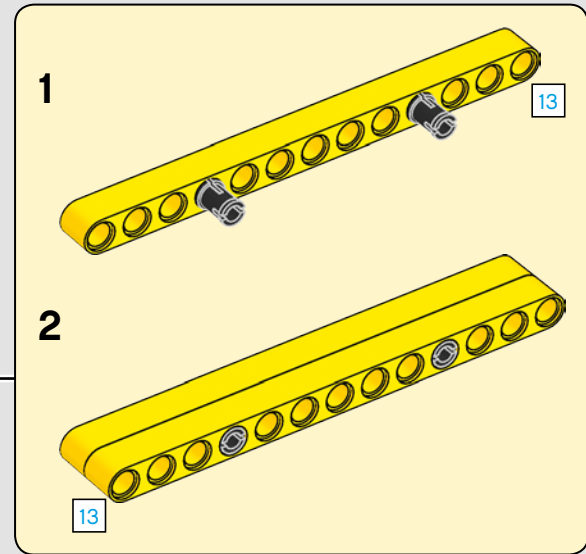

12

3x 2x 1x

# 166

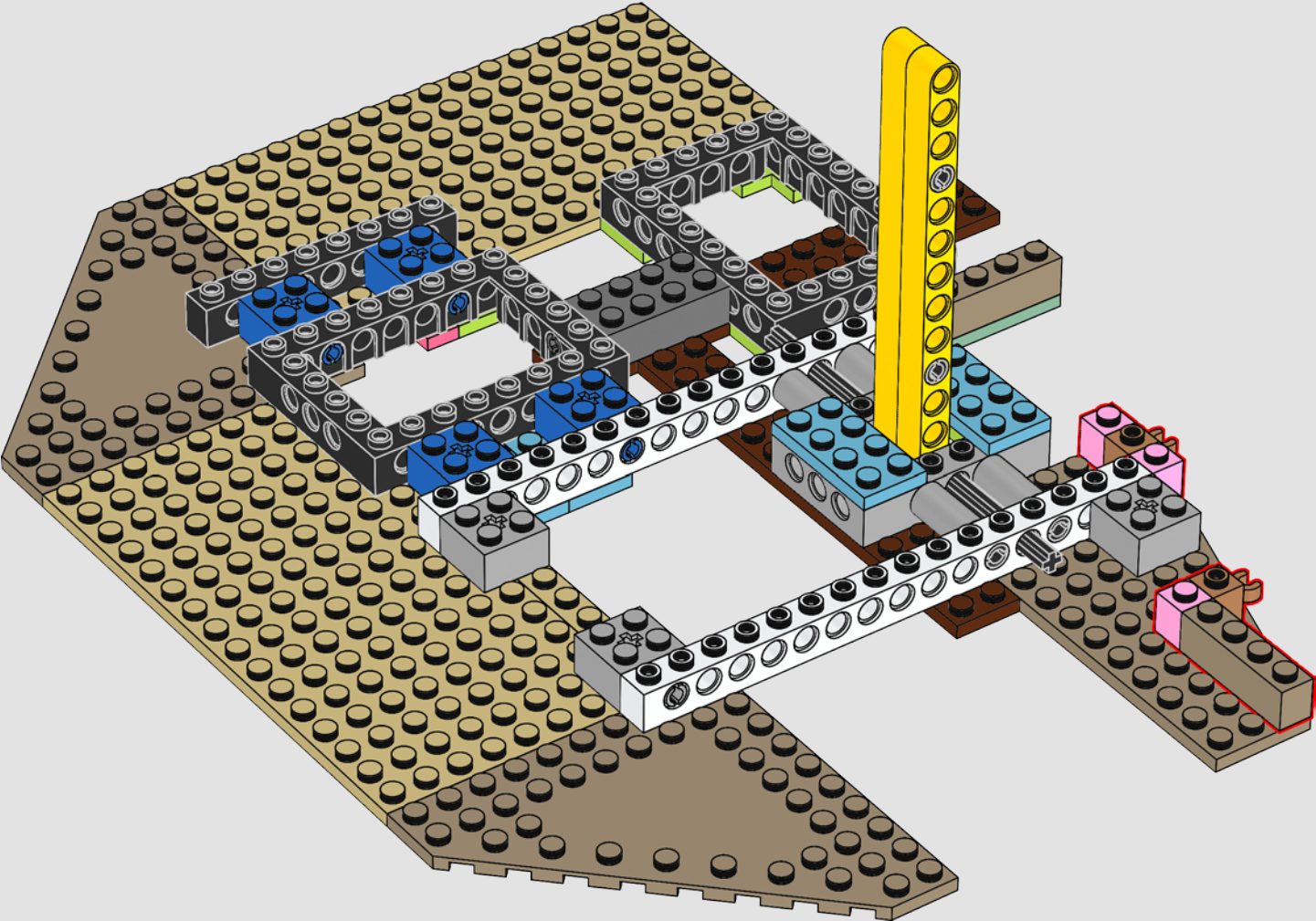

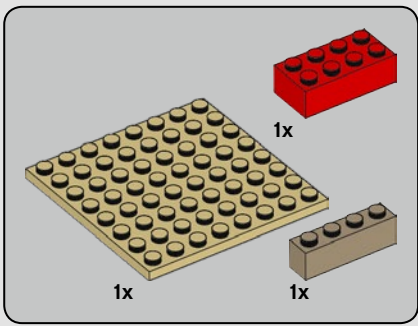

167

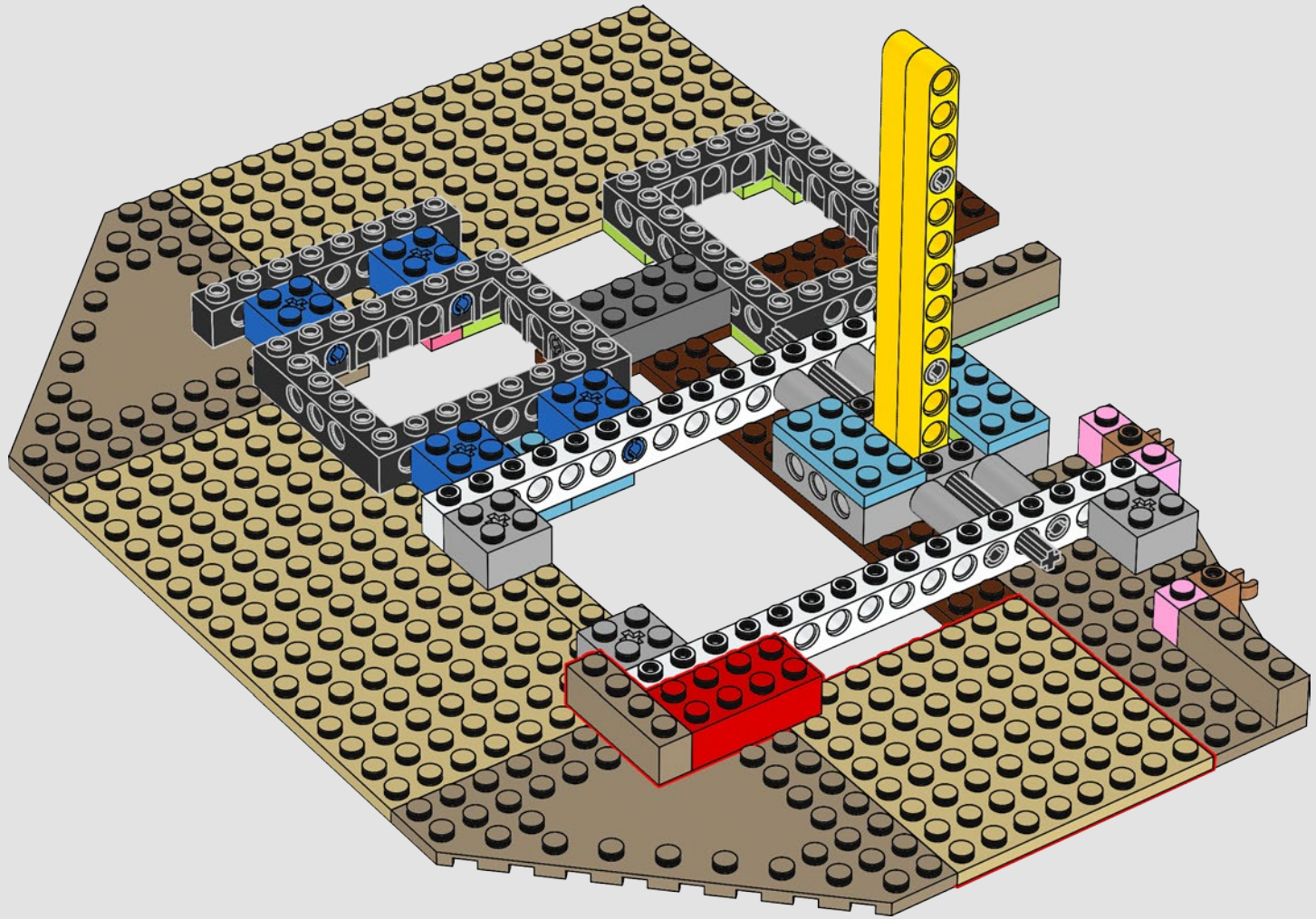

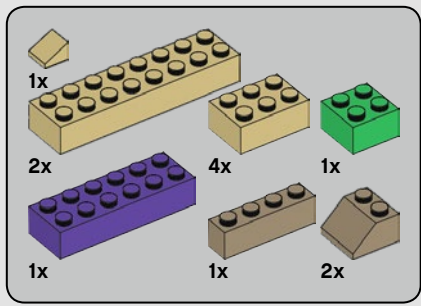

168

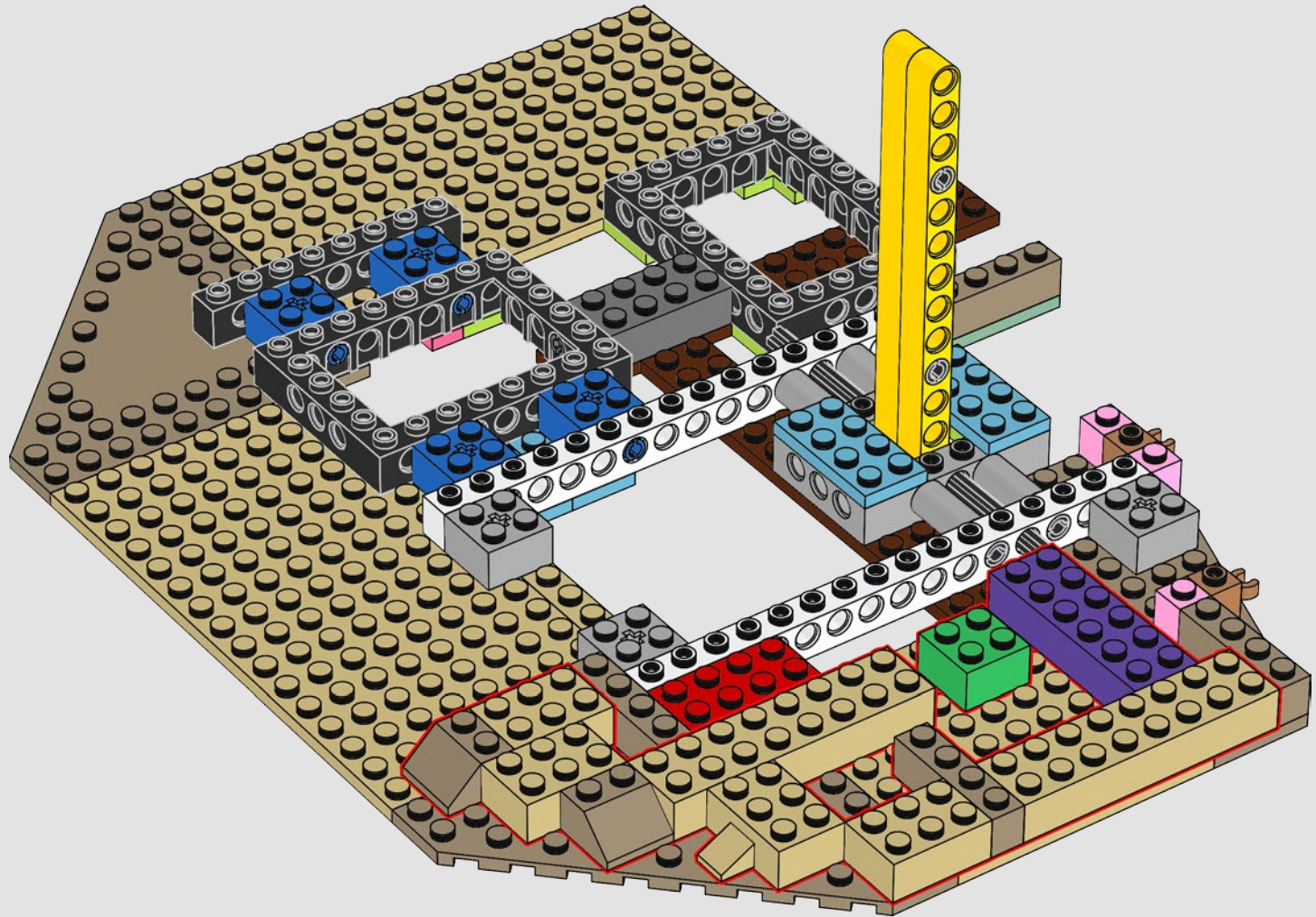

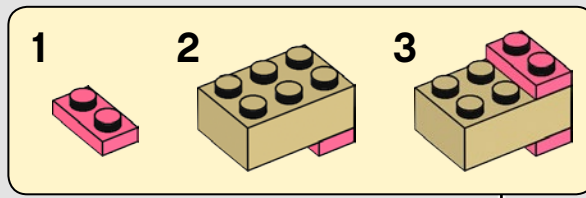
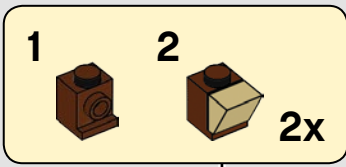
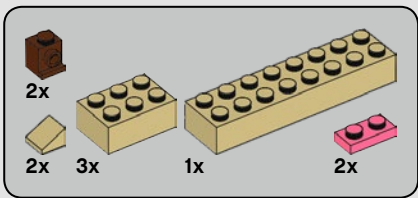

169

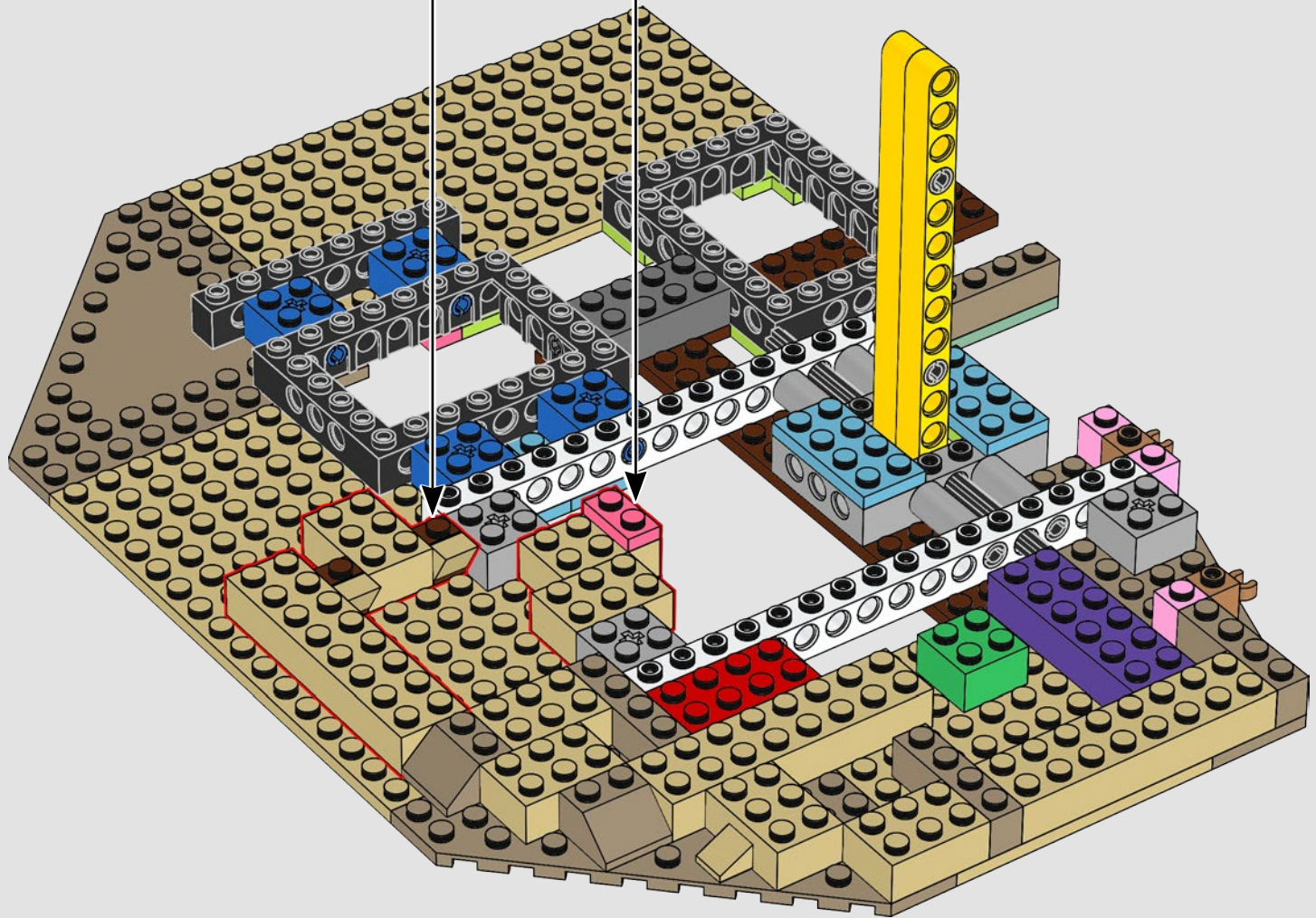

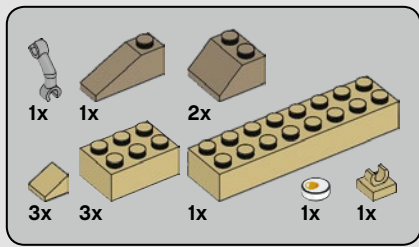

170

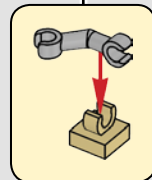
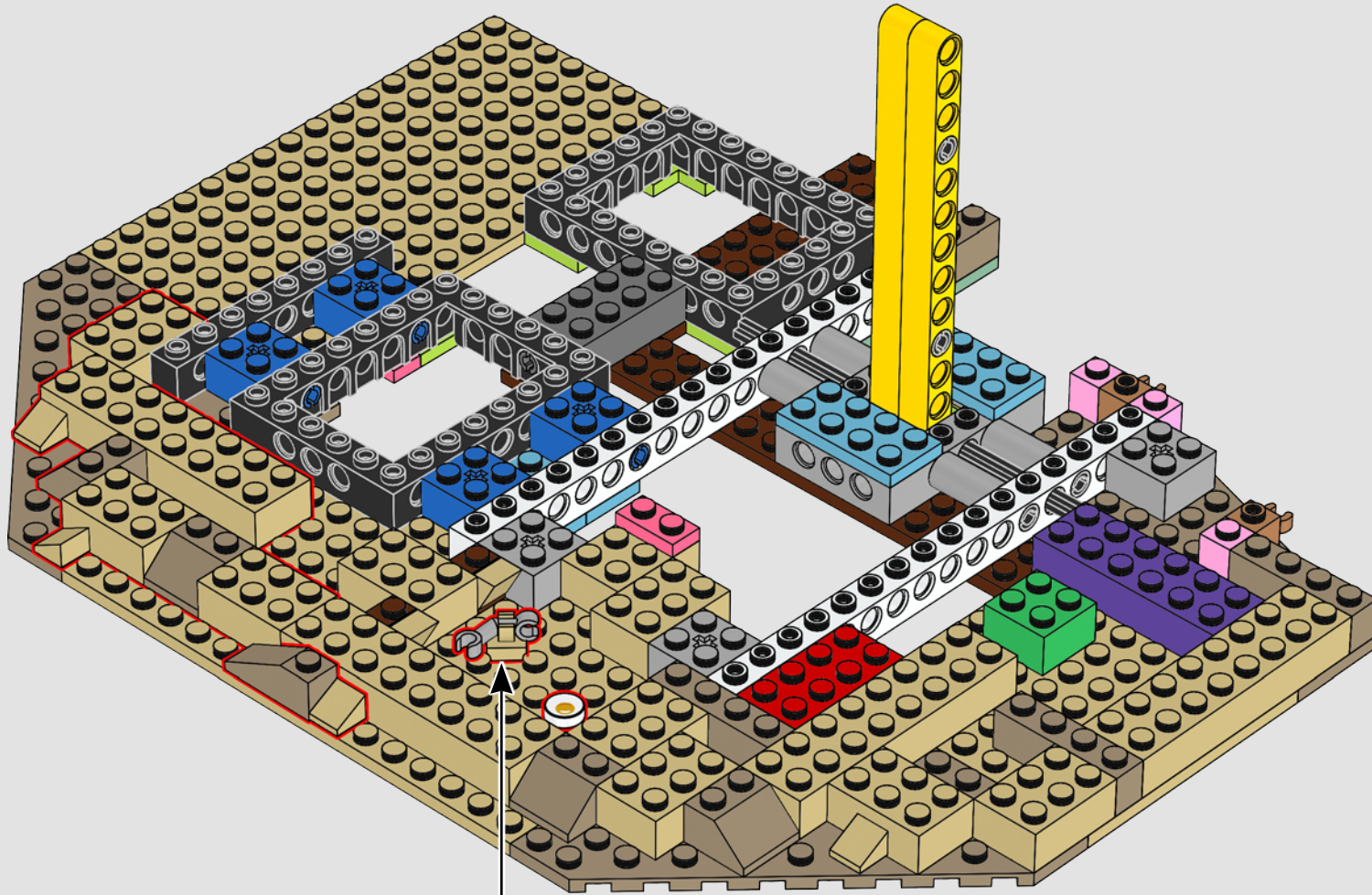



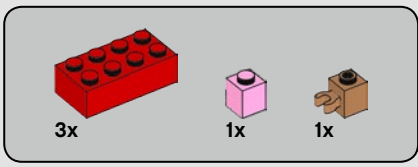

171

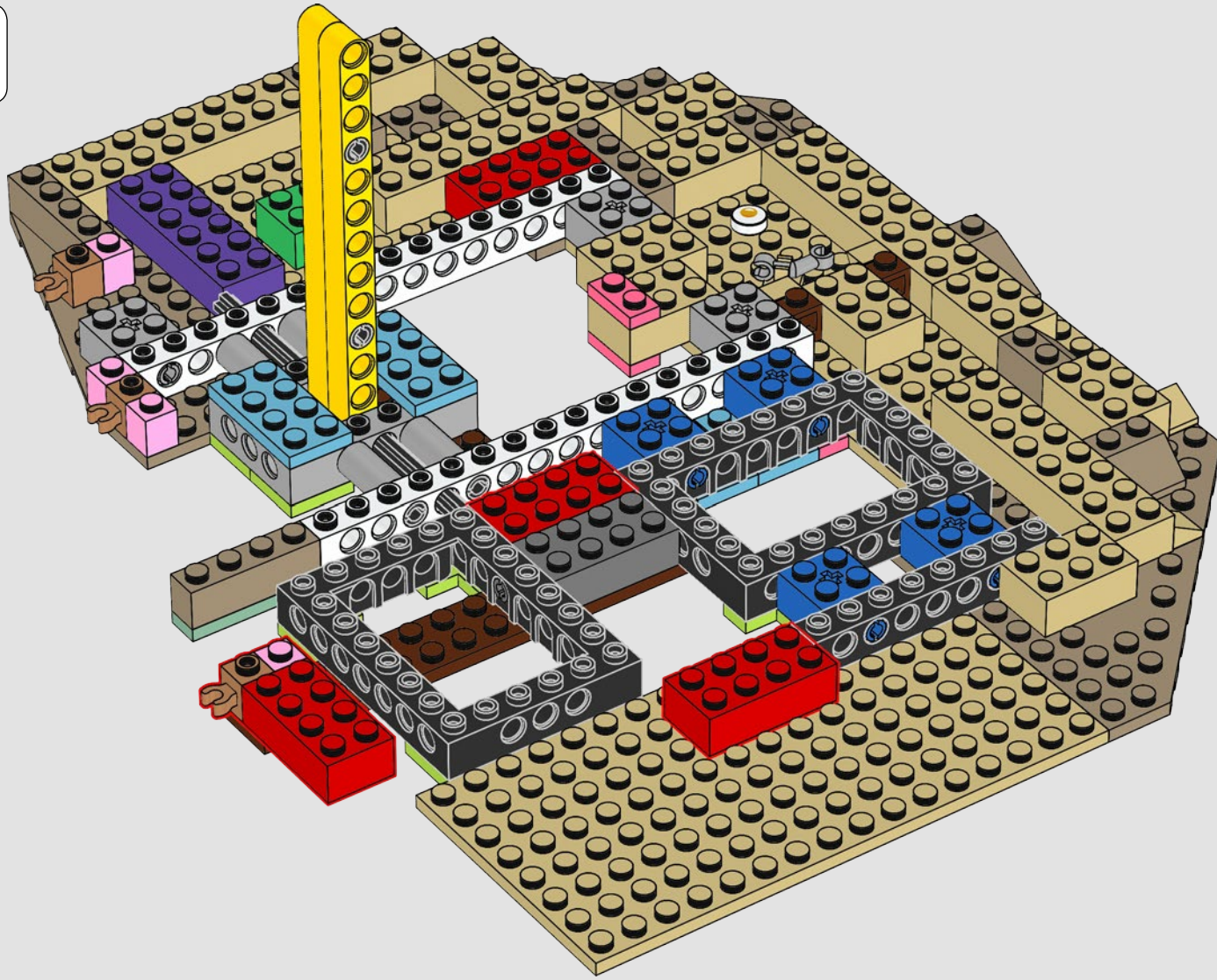
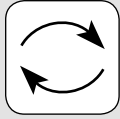

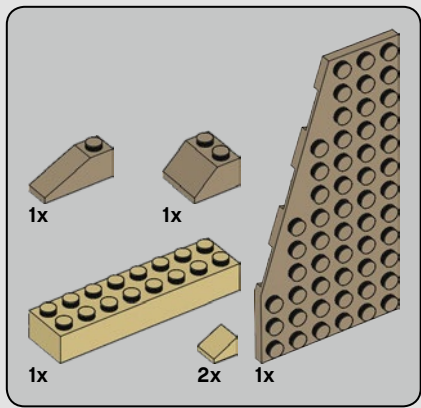

172

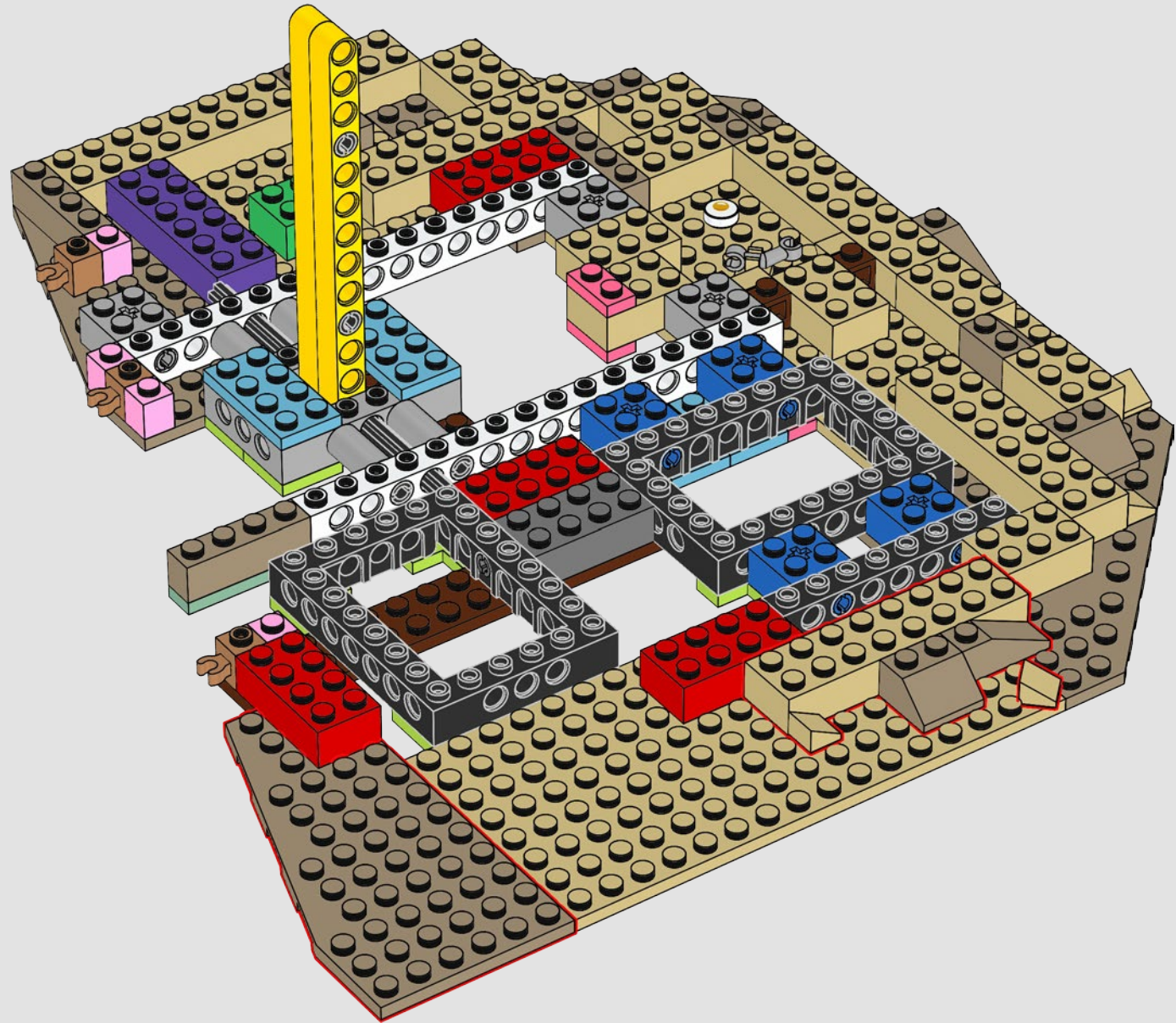

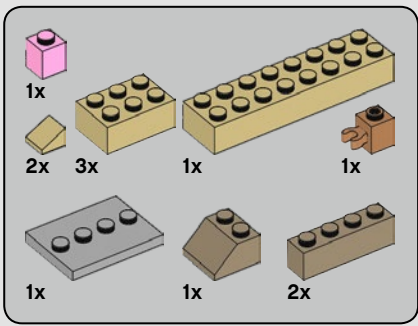

173

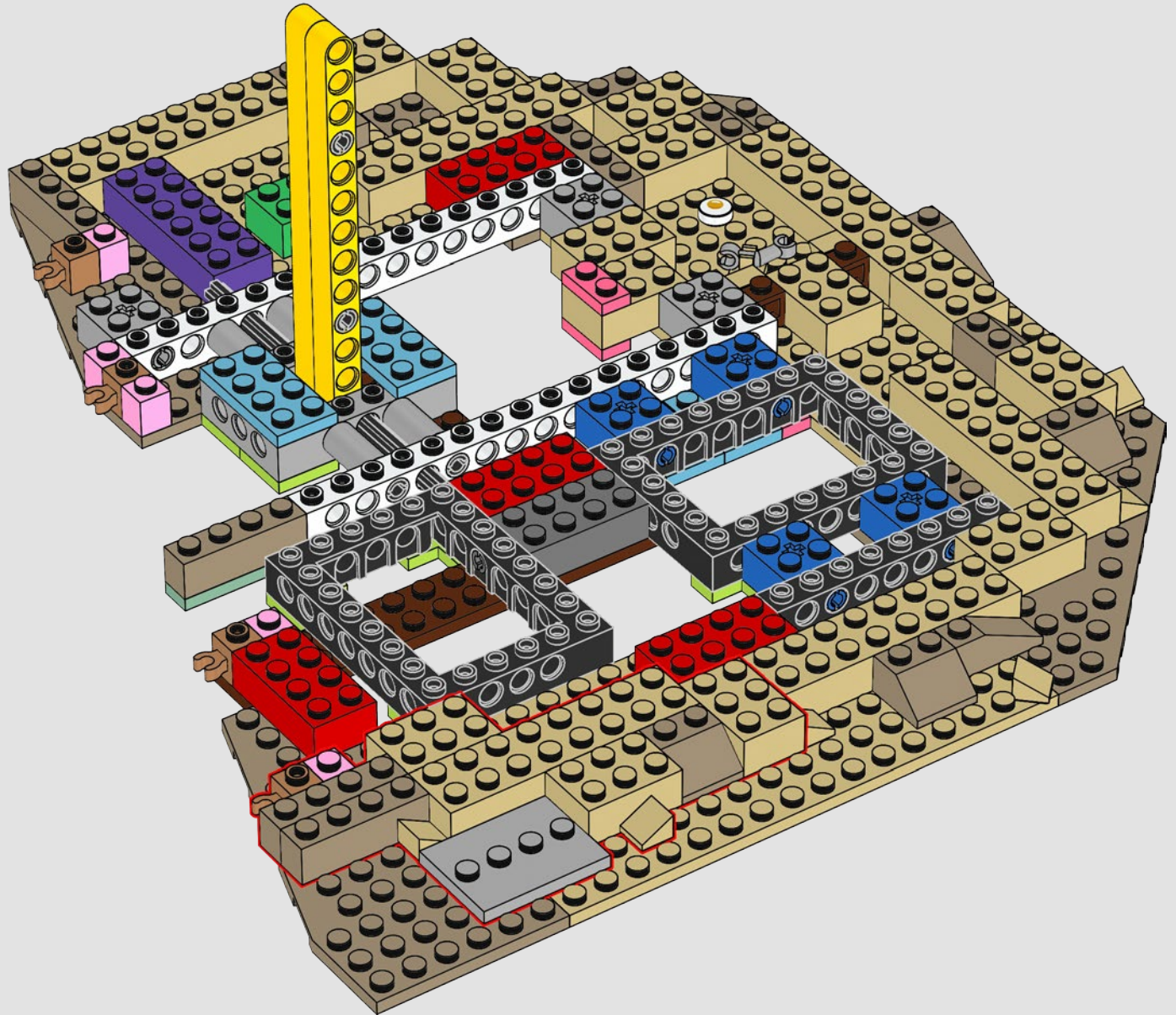

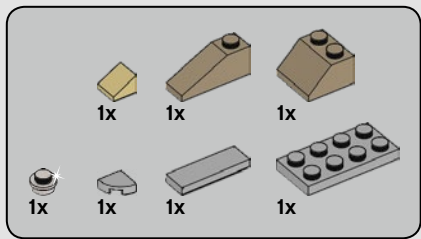

174

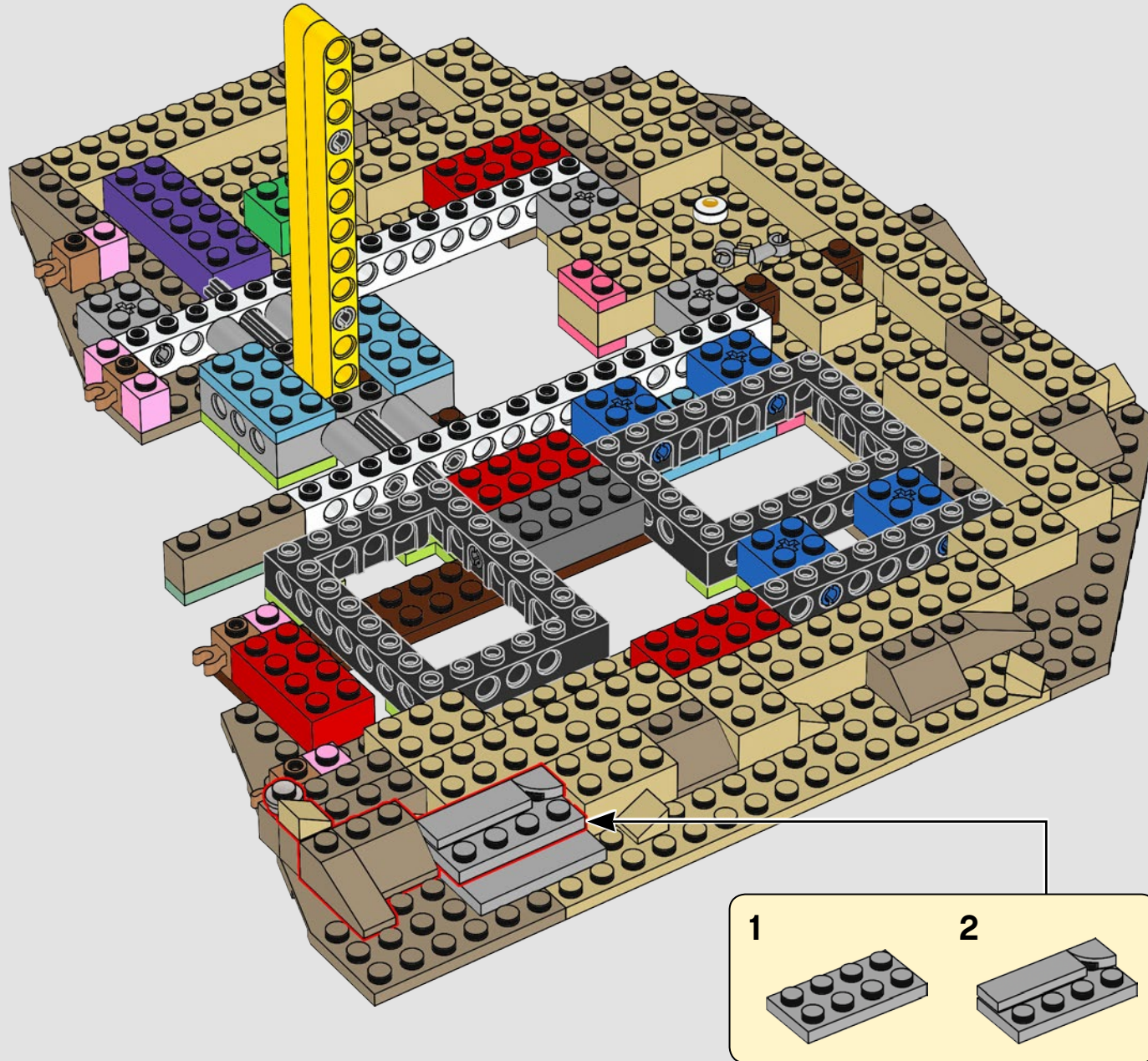

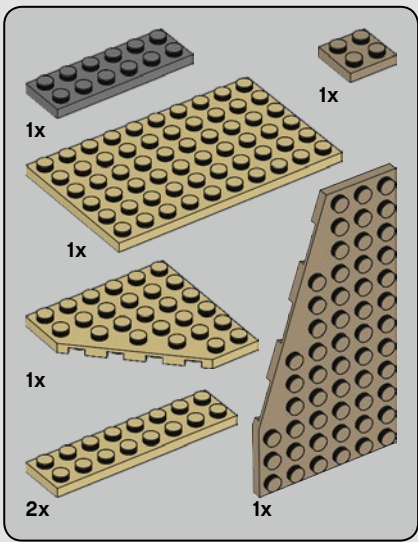

175

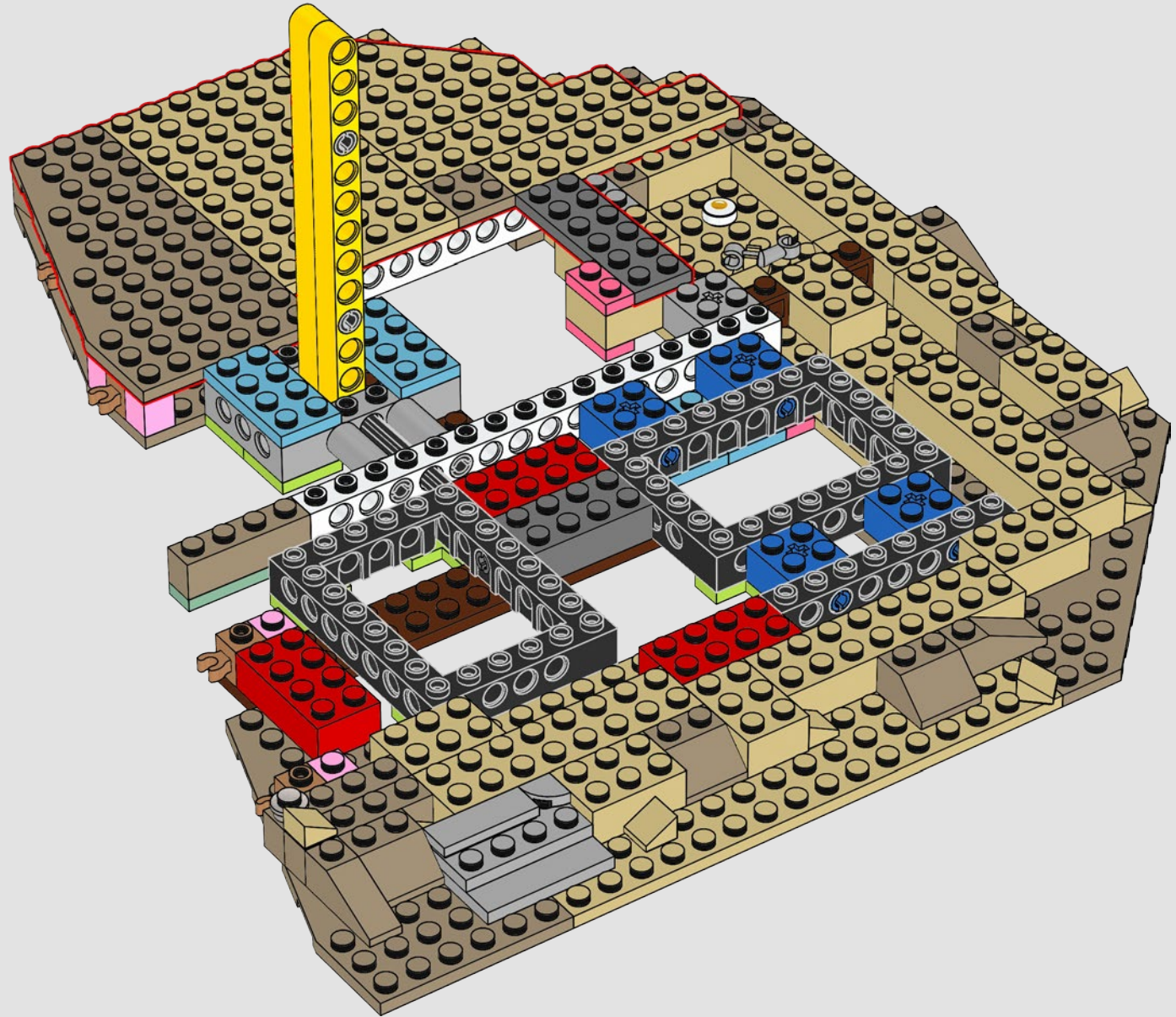

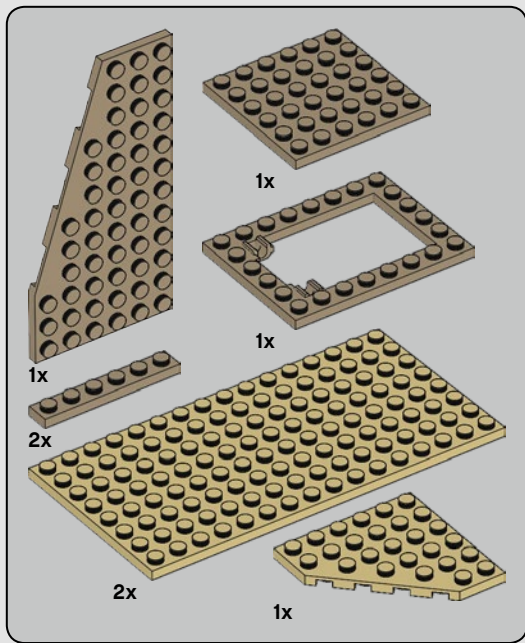

176

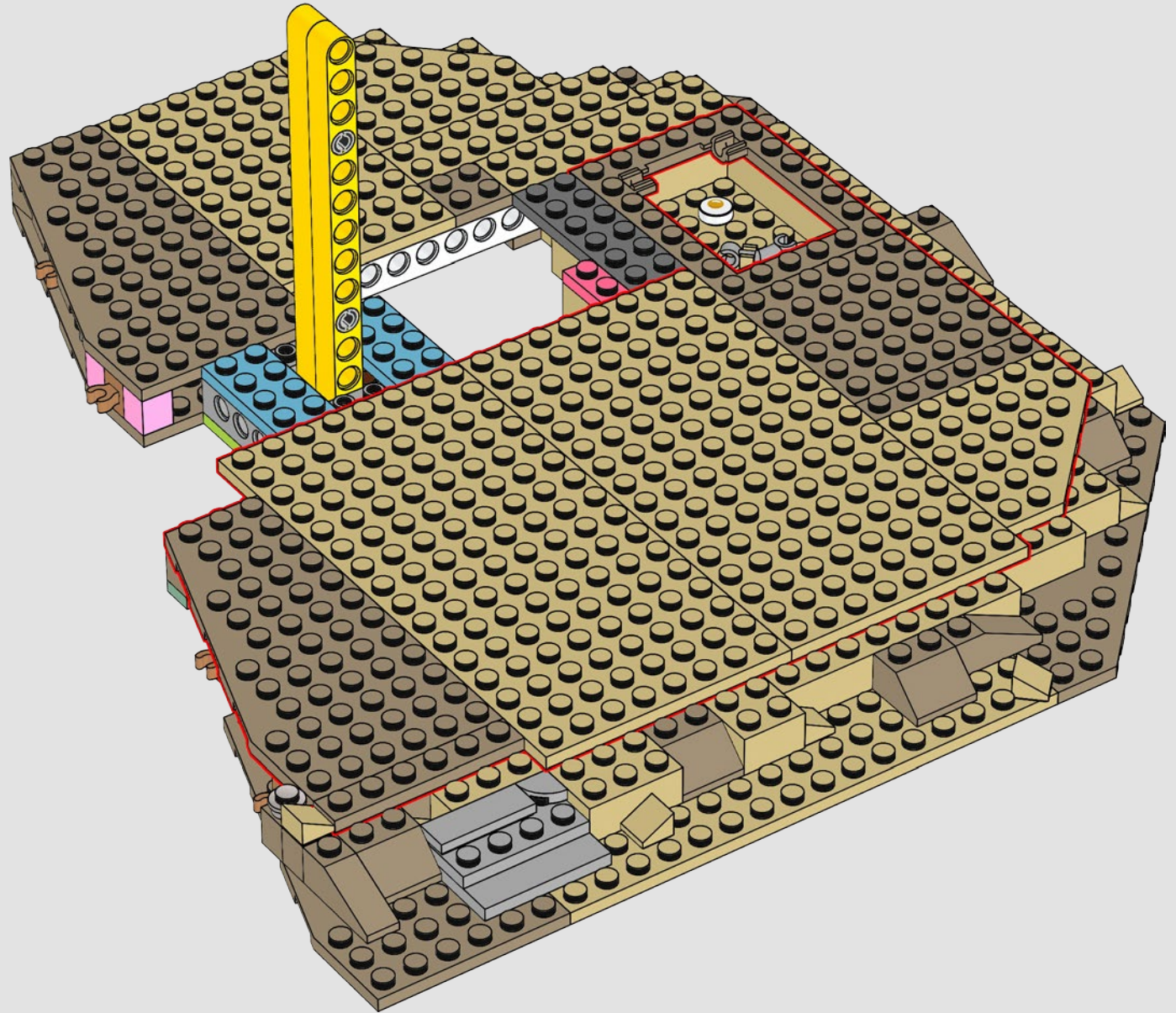

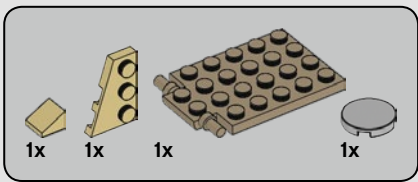

177

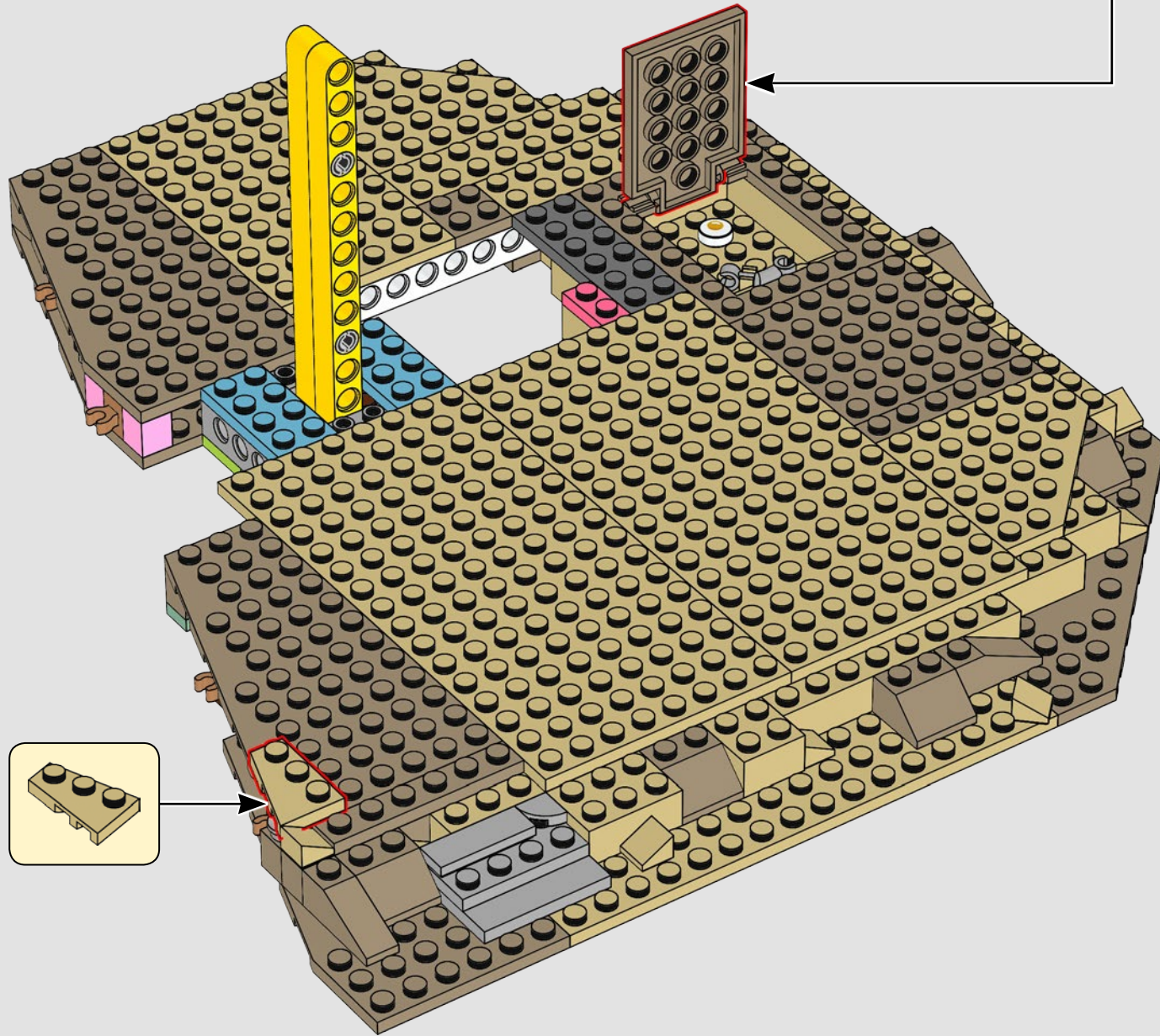
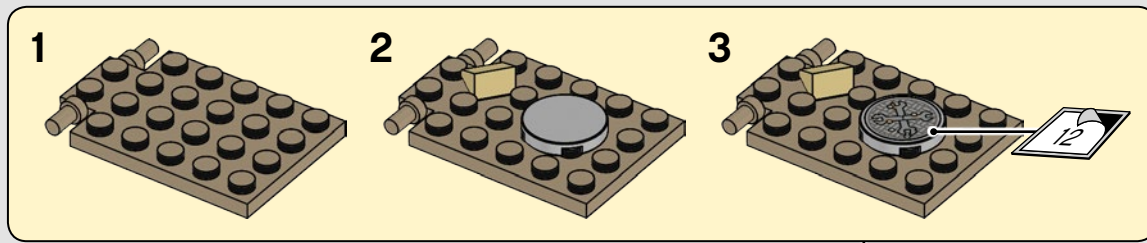

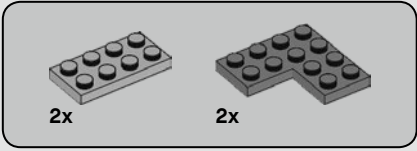

178

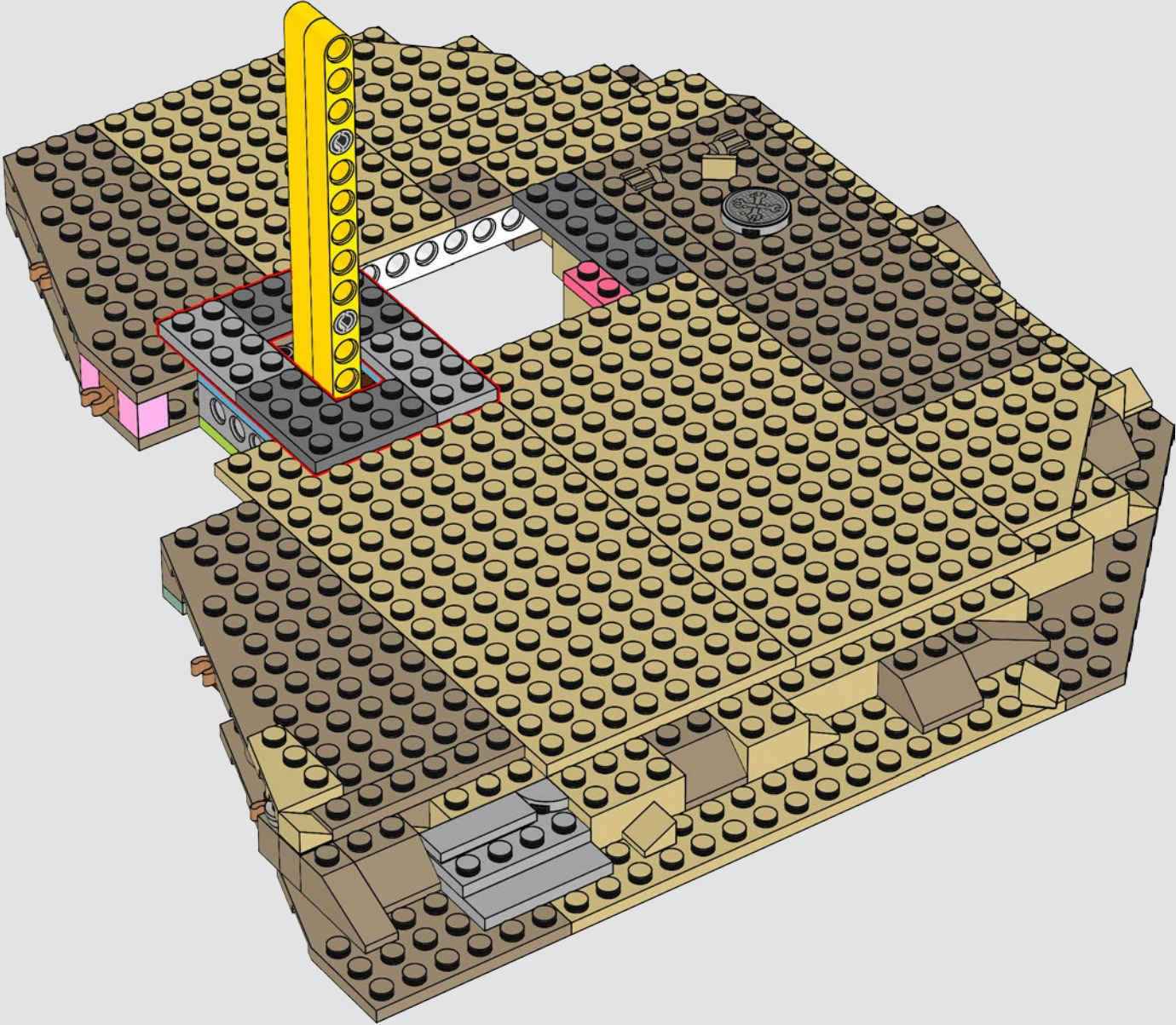



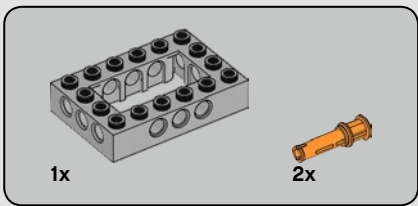

179

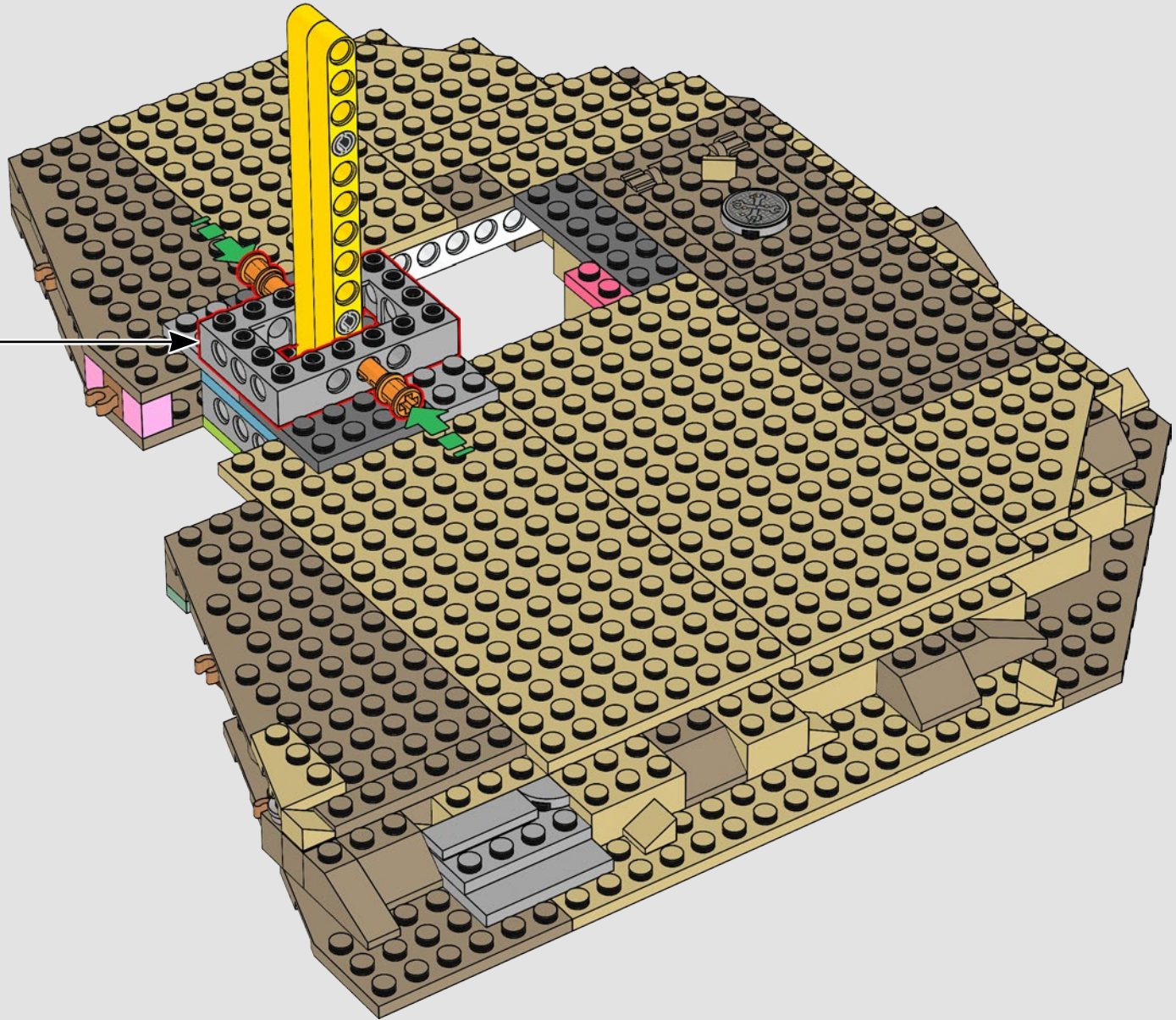
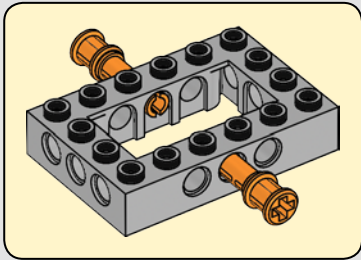



4x

180

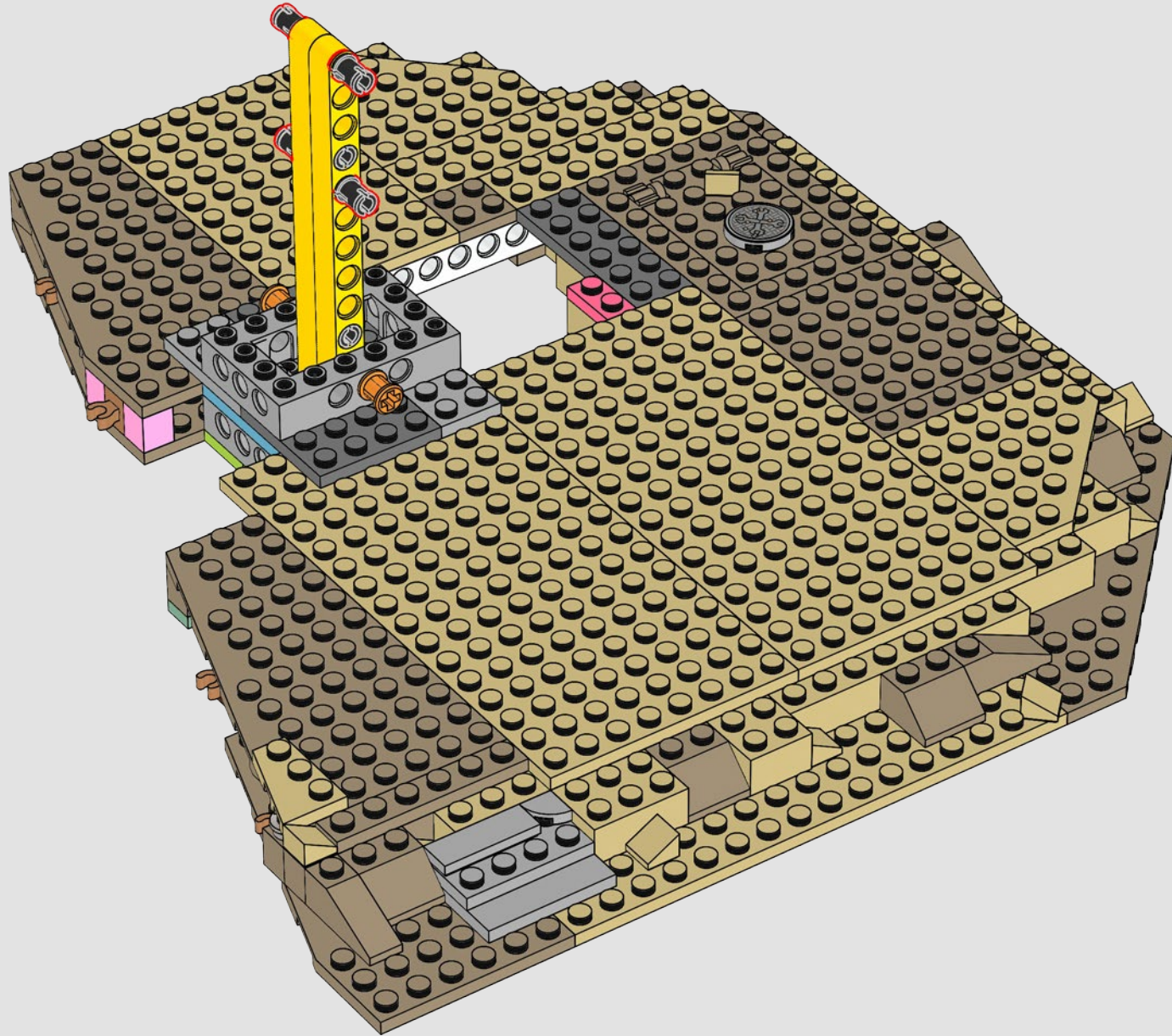

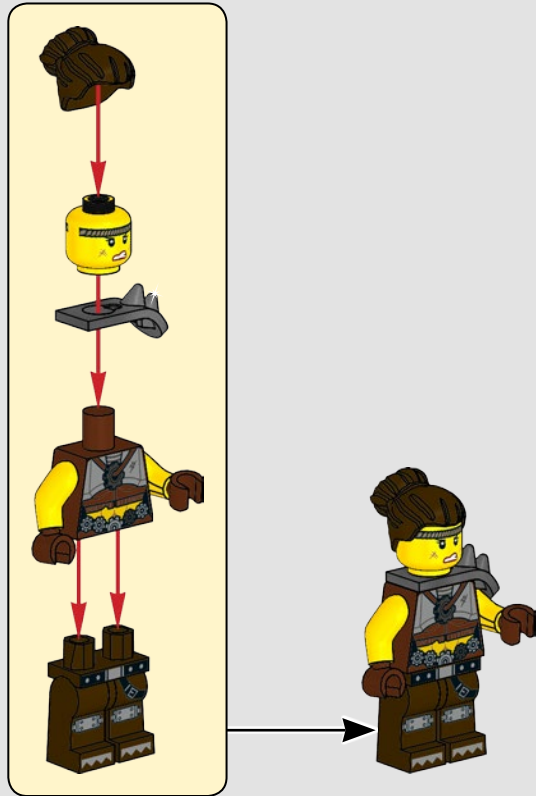
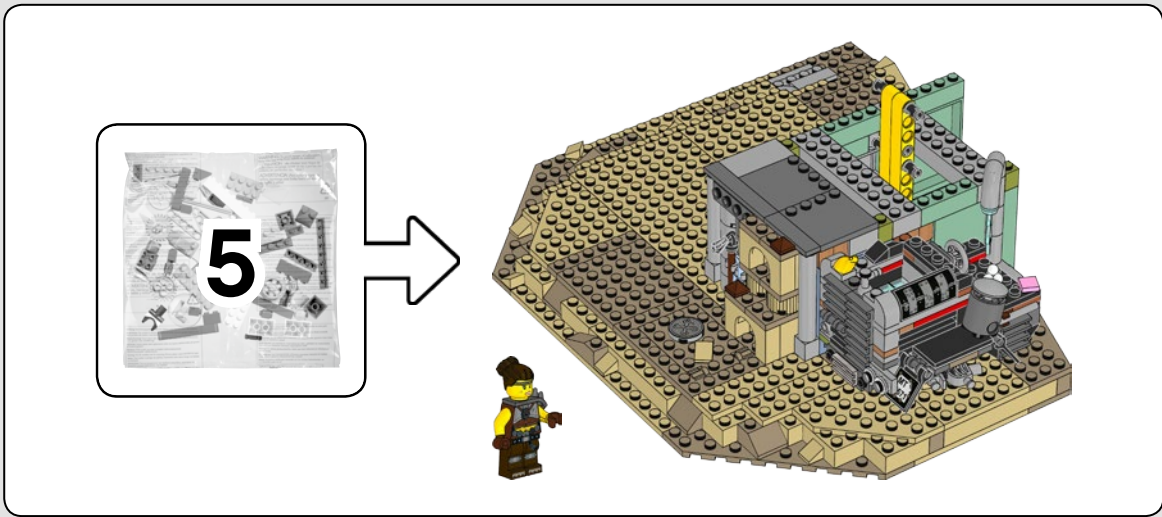

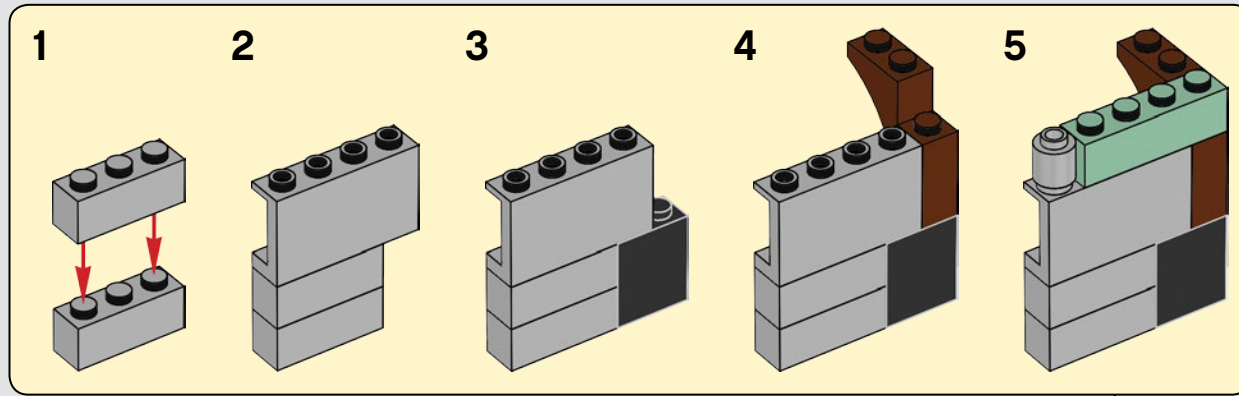
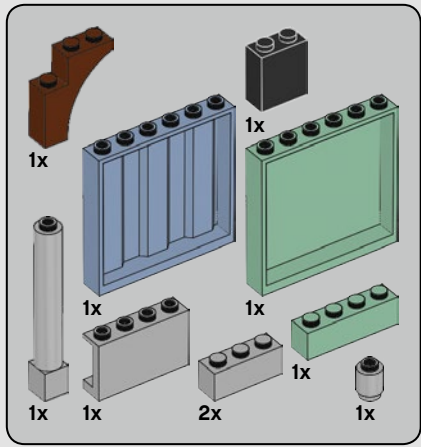

181

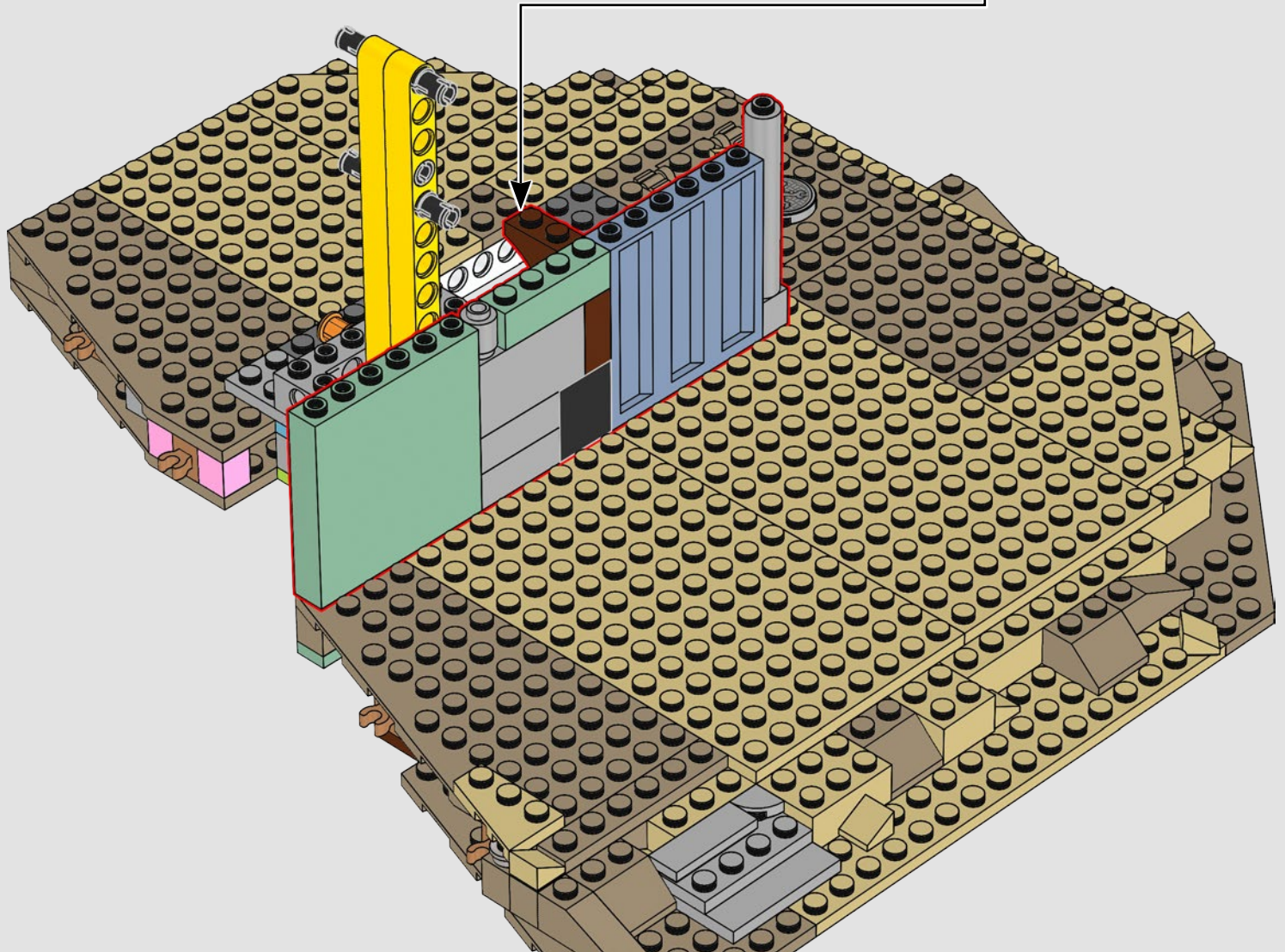

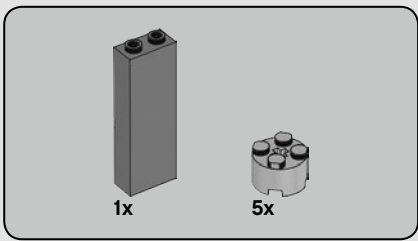

182

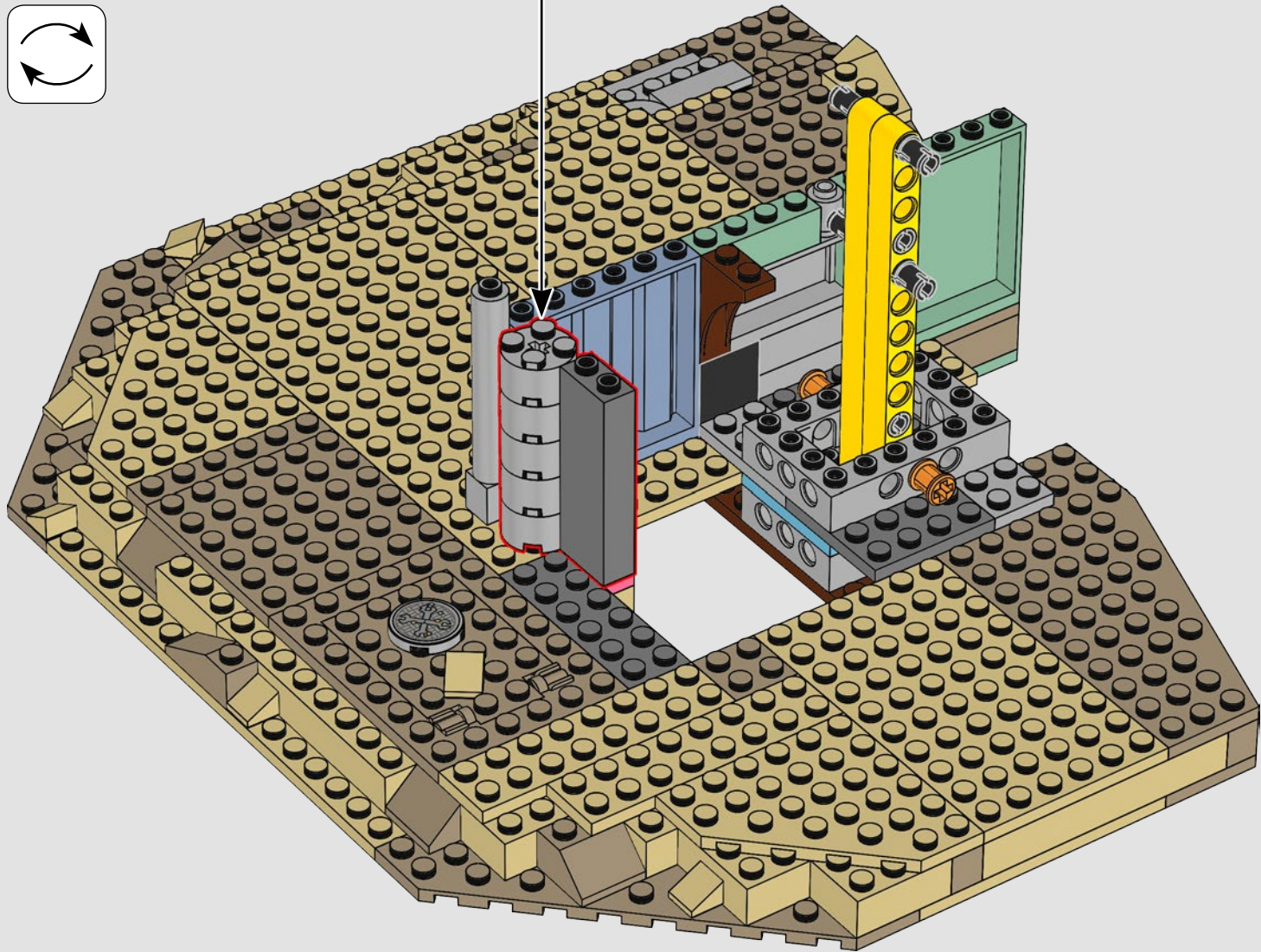
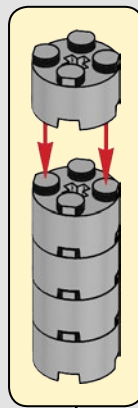
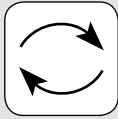

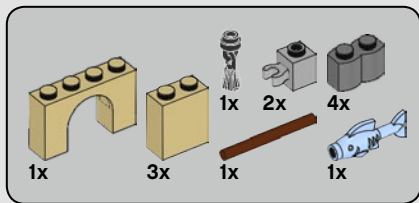

183

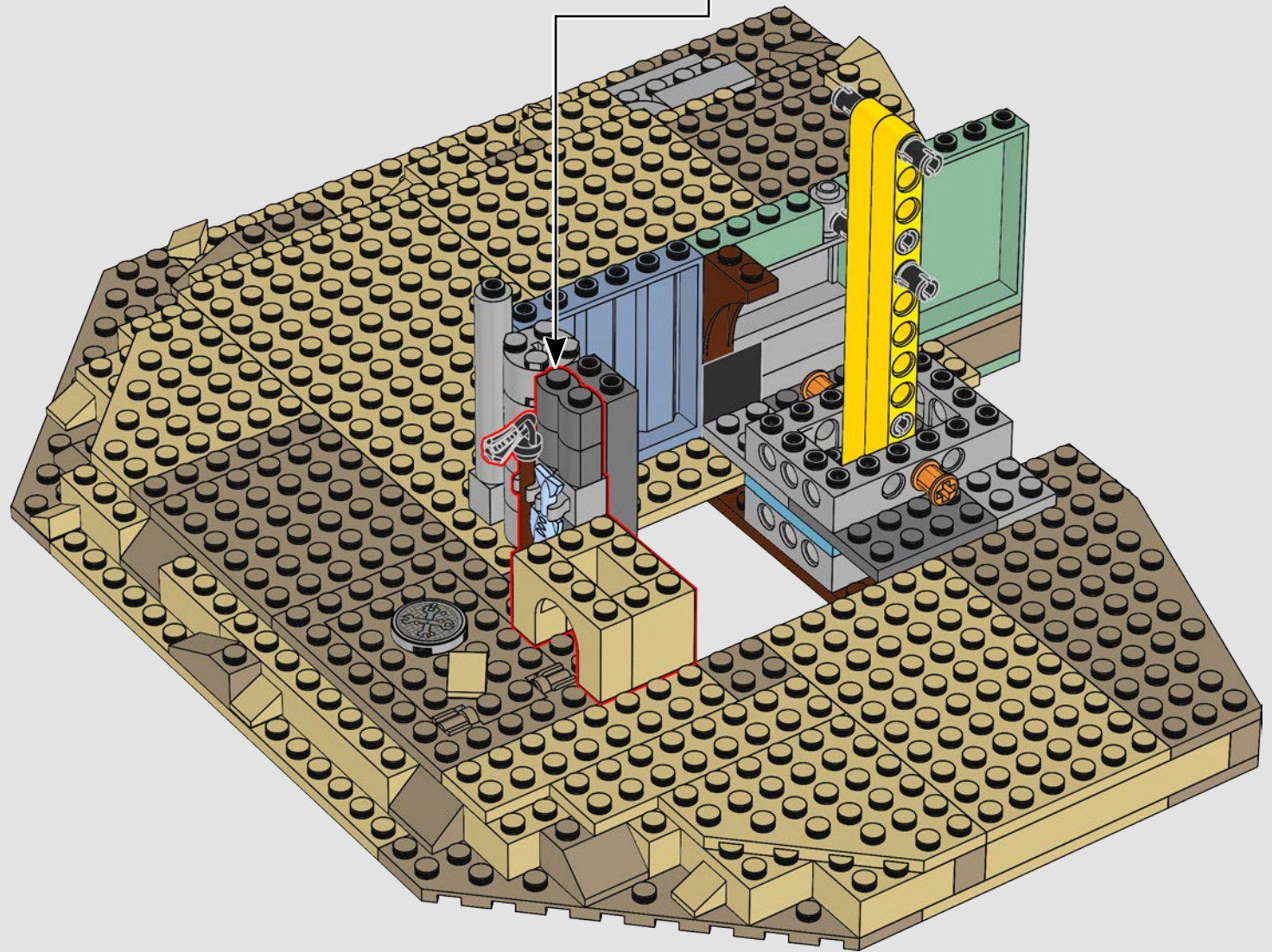
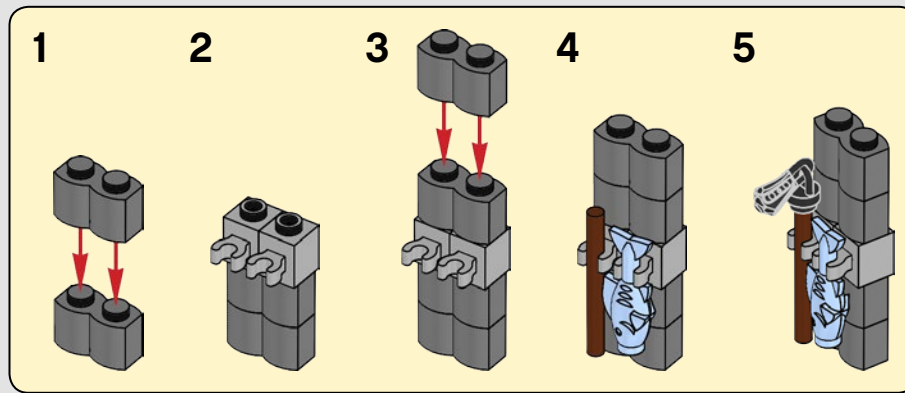

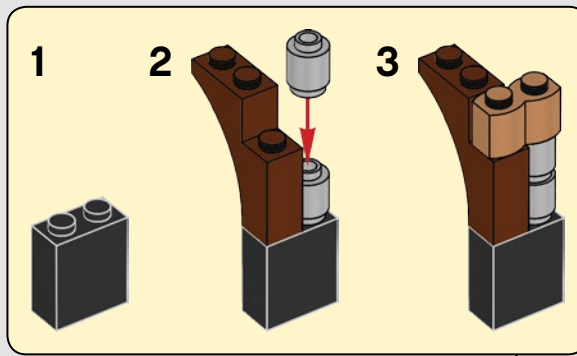
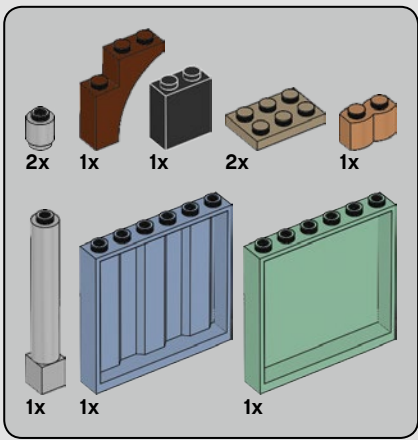

184

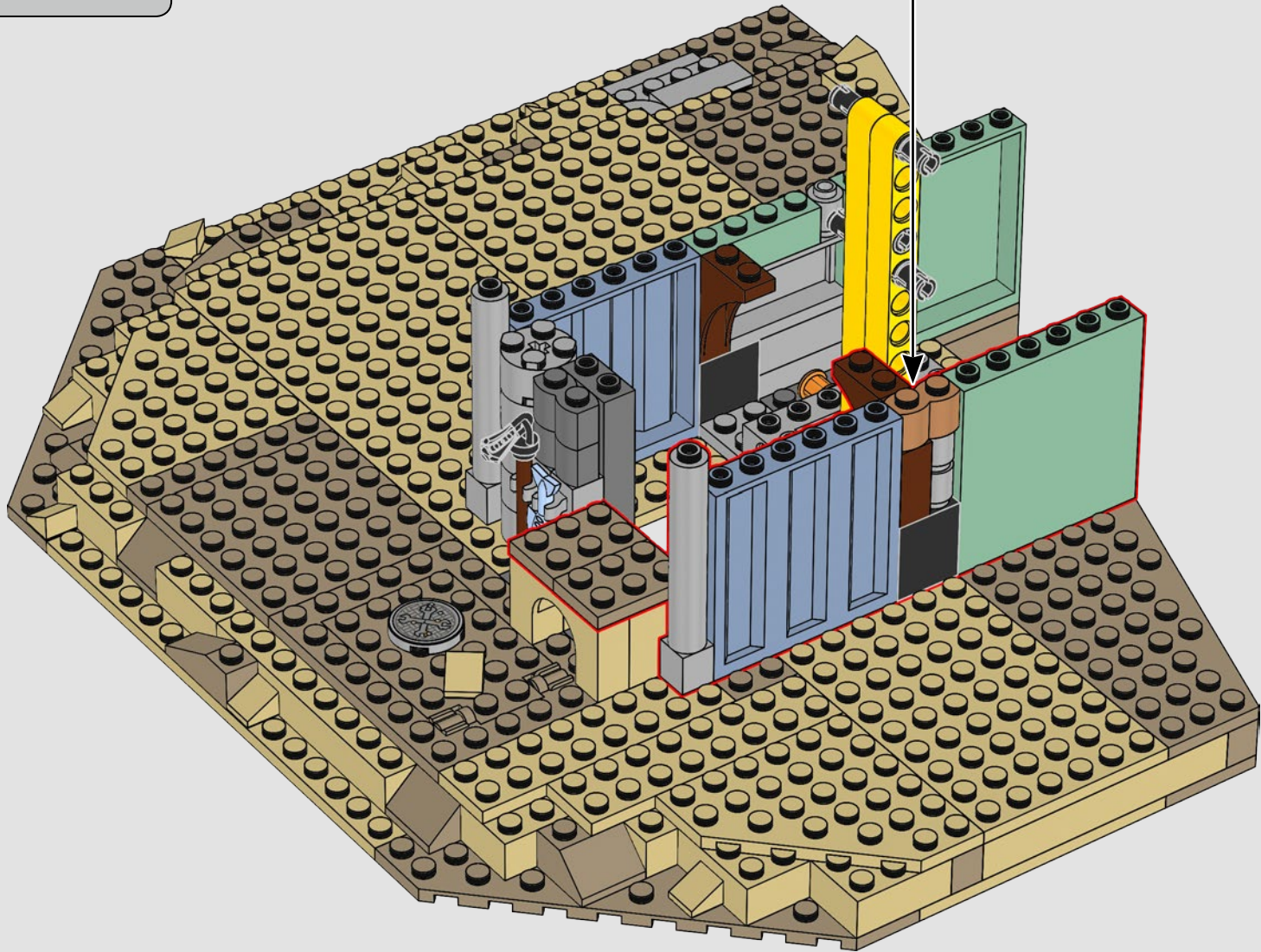

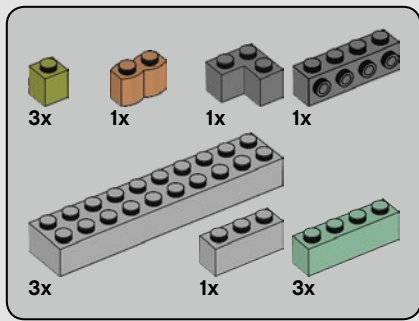

185

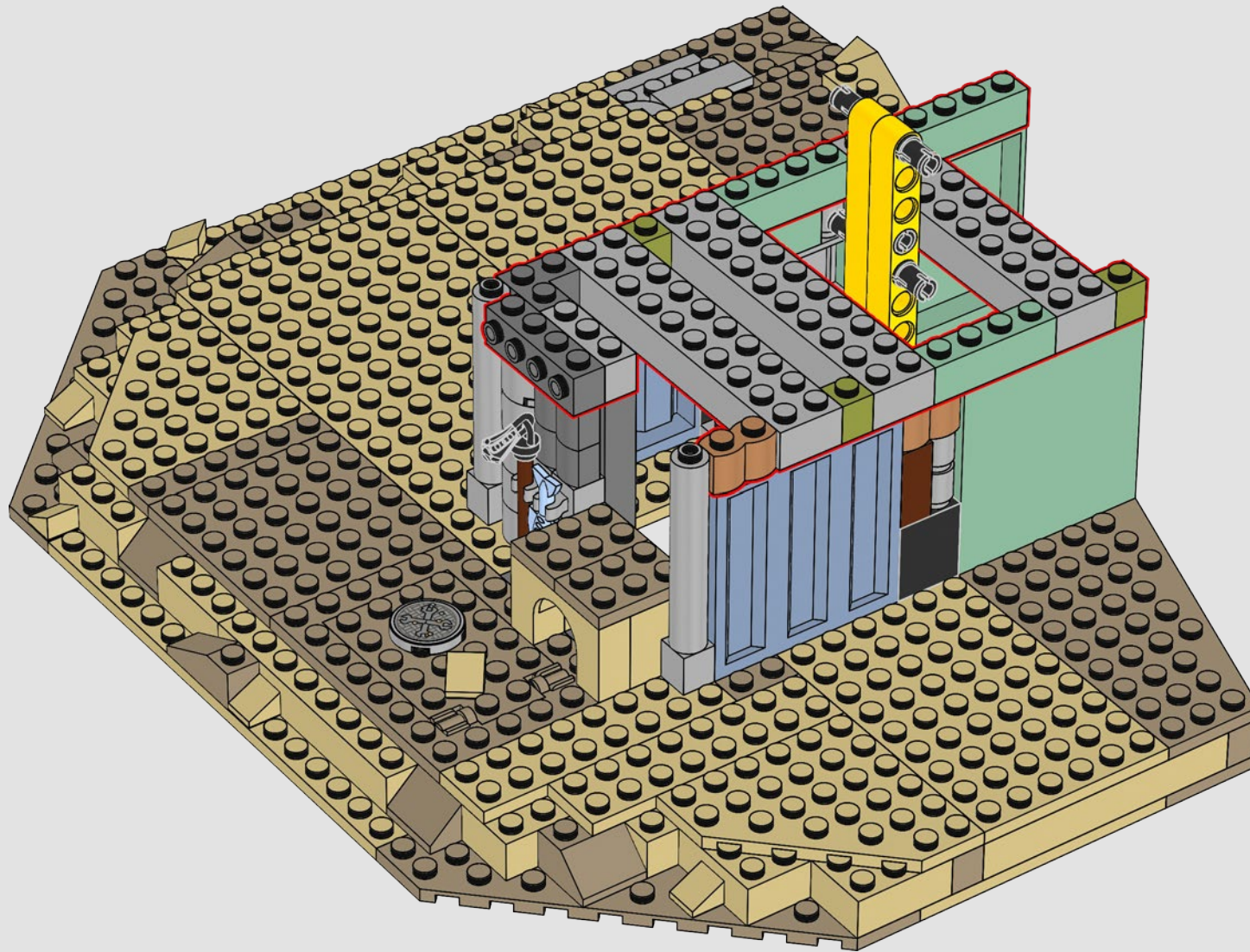



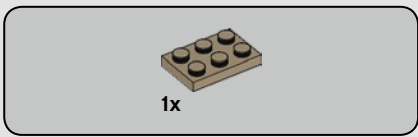

186

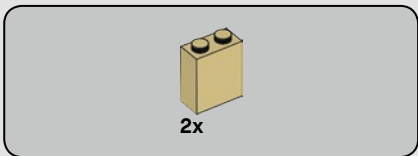

187

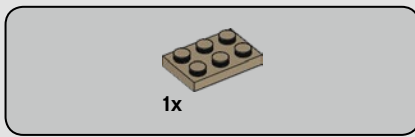
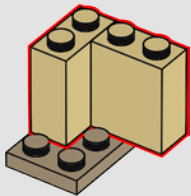

188

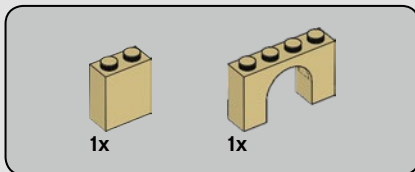
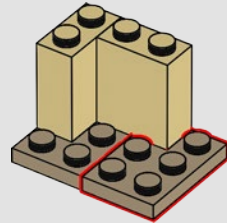

189

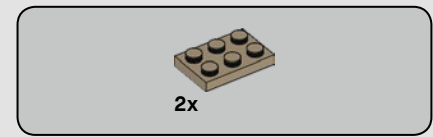
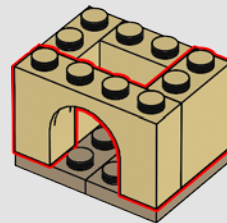

190

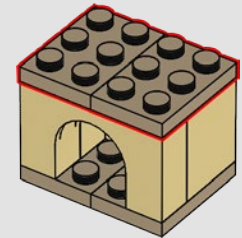

191

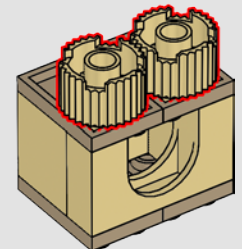
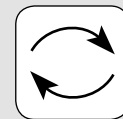

192

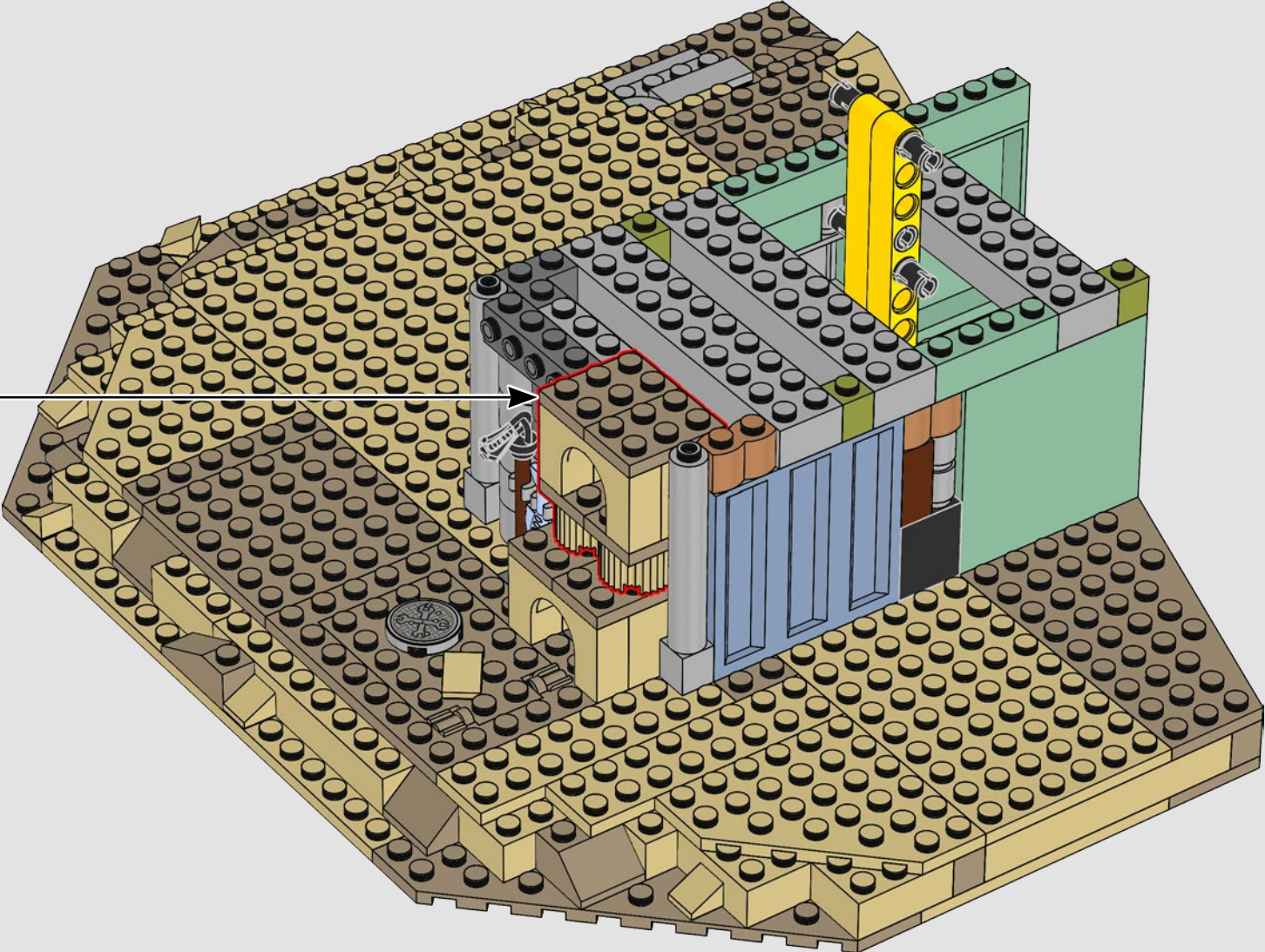

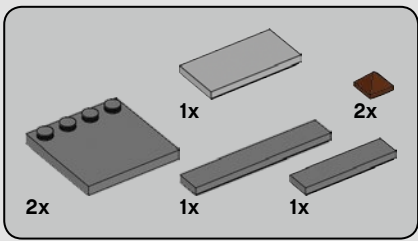

193

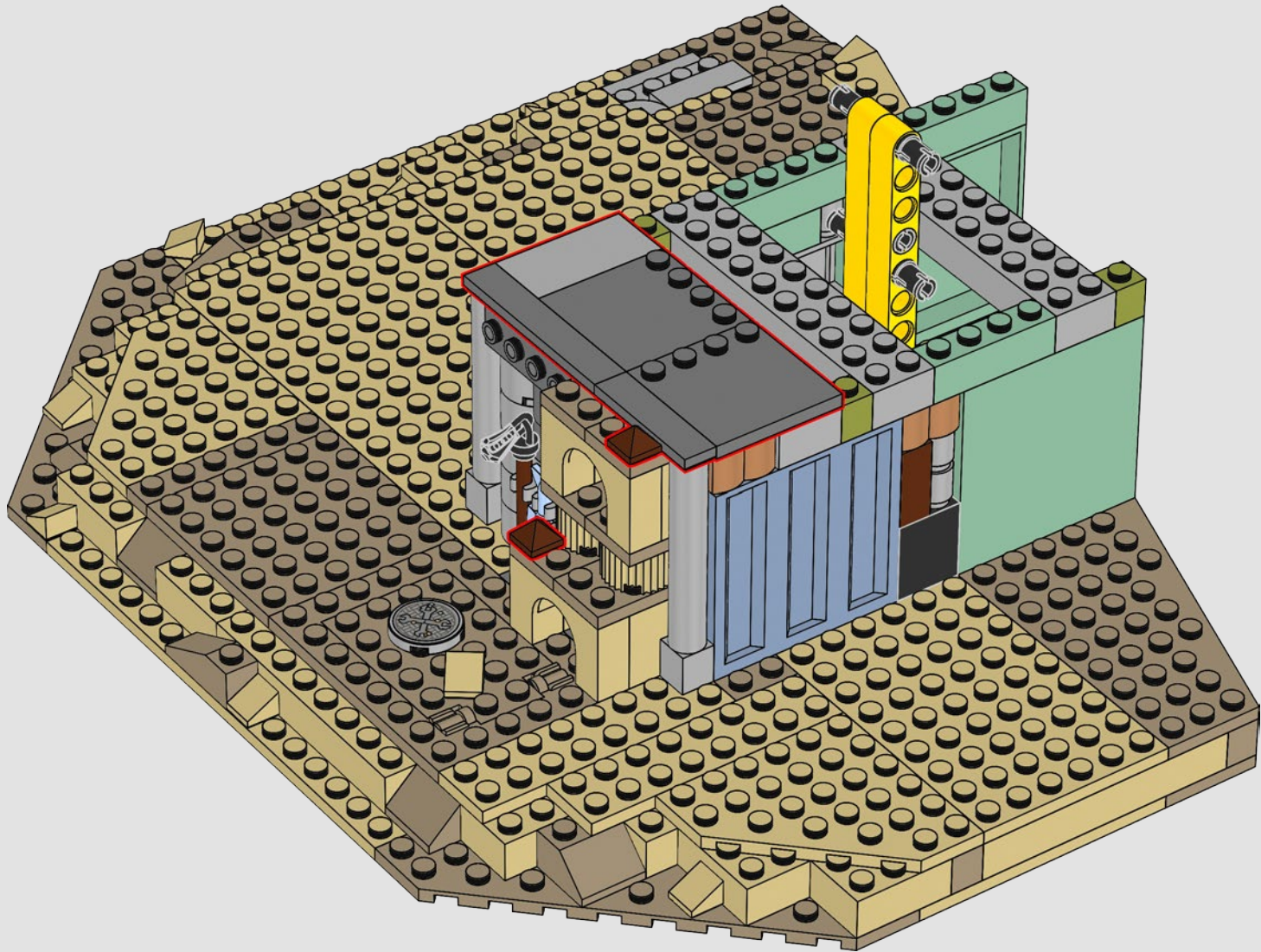

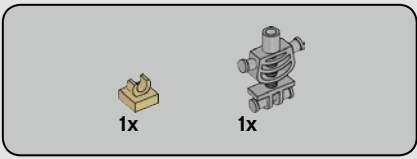

194

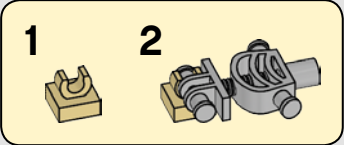
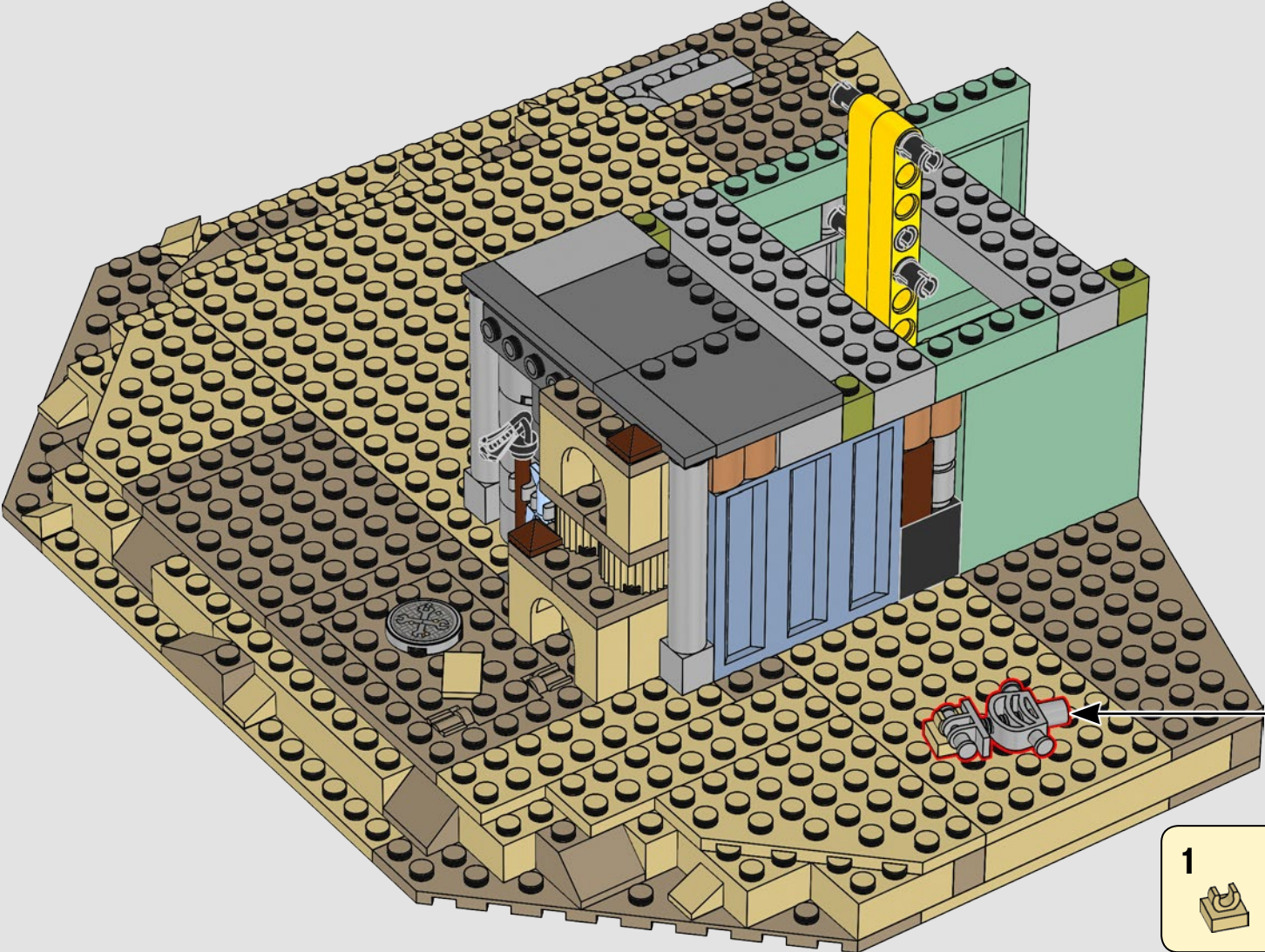

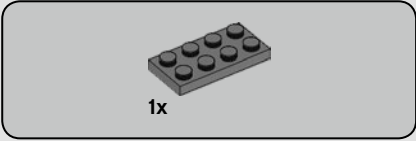
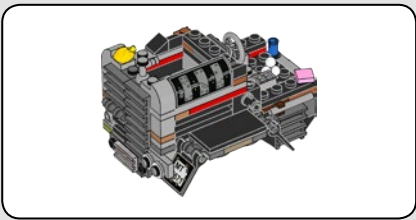

195

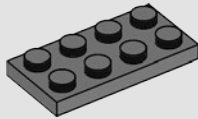

196

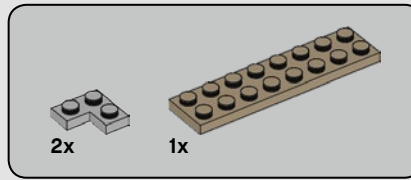
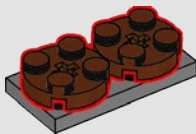

197

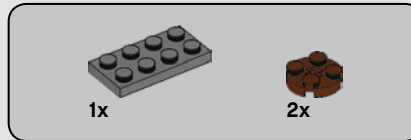
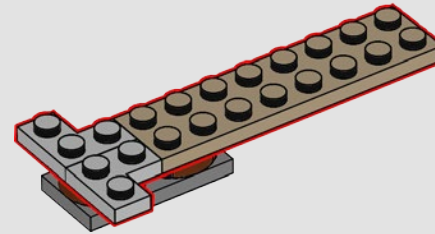

198

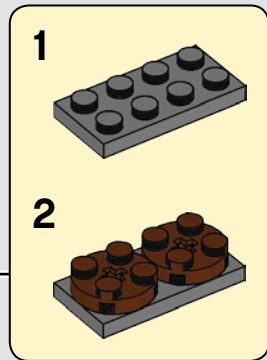
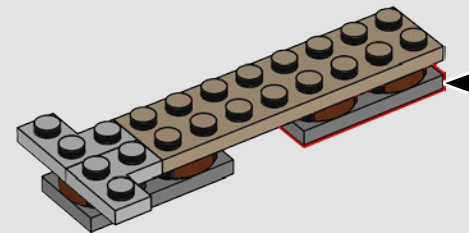

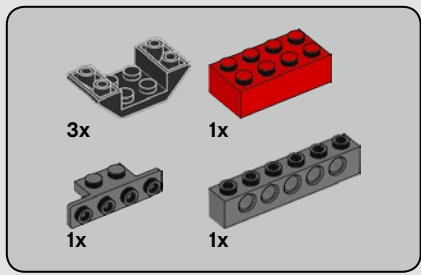

199

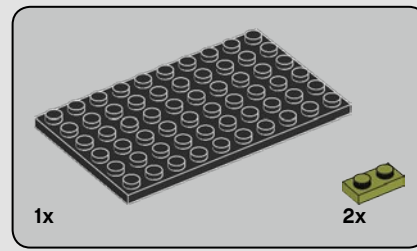
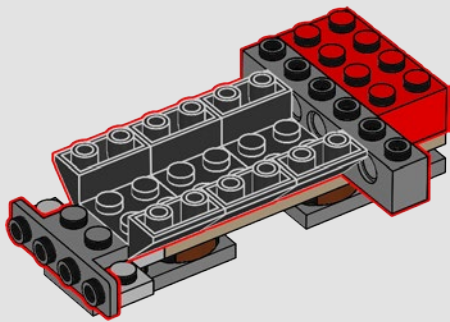

200

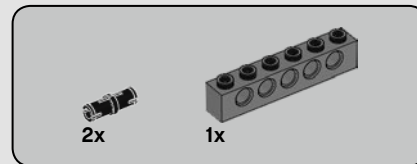
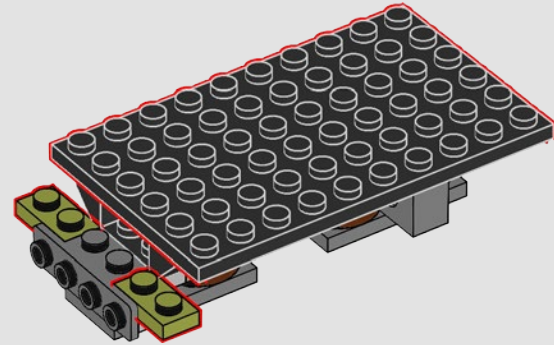

201

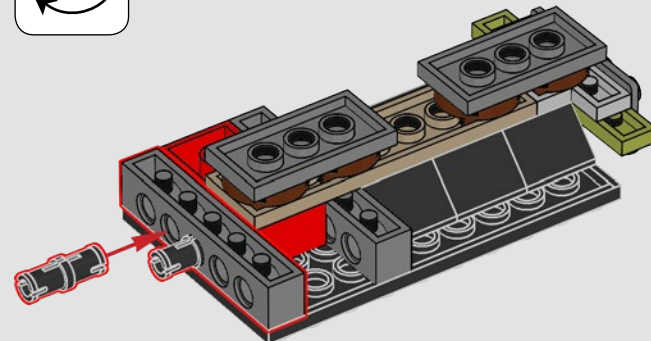
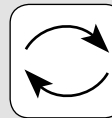

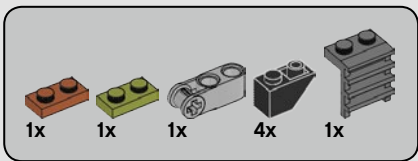

202

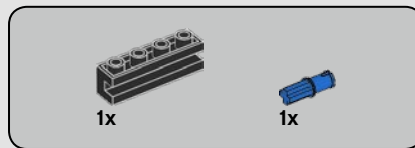
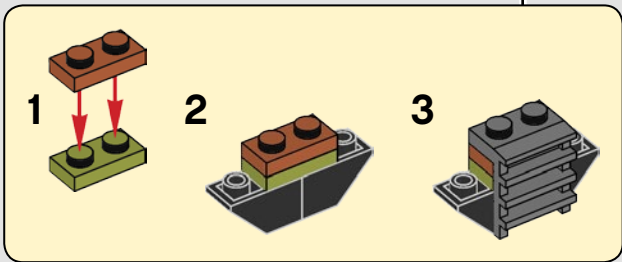
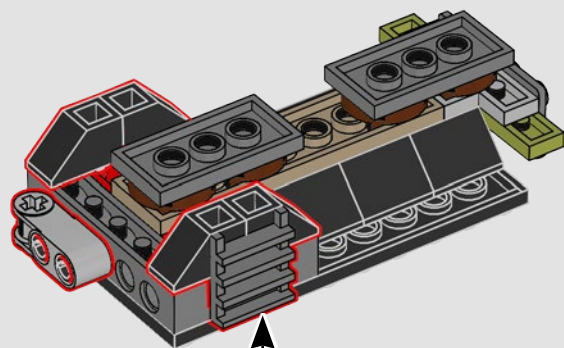

203

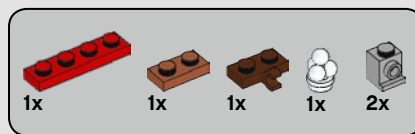
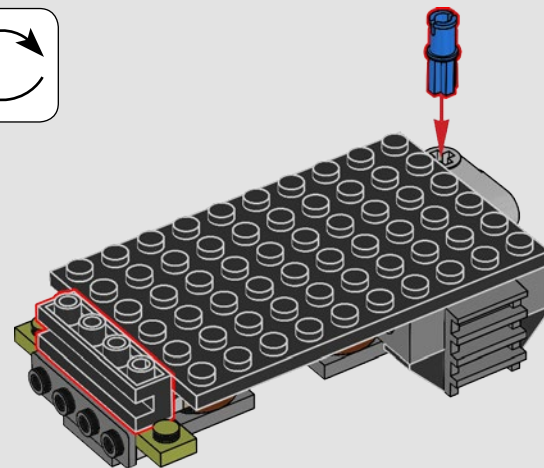
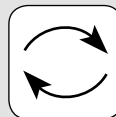

204

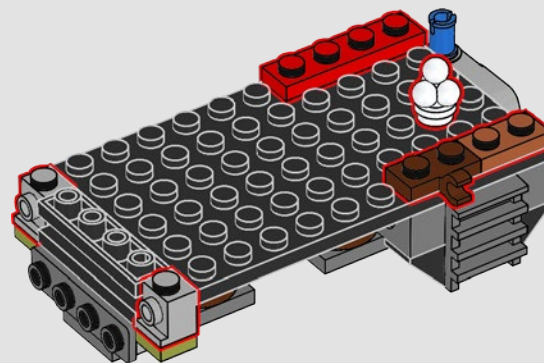

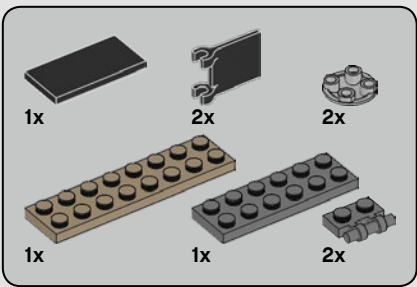

205

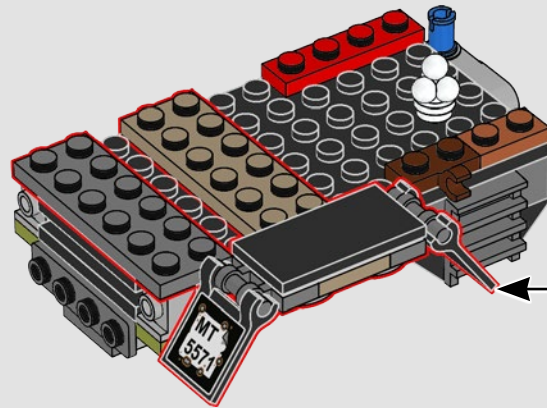
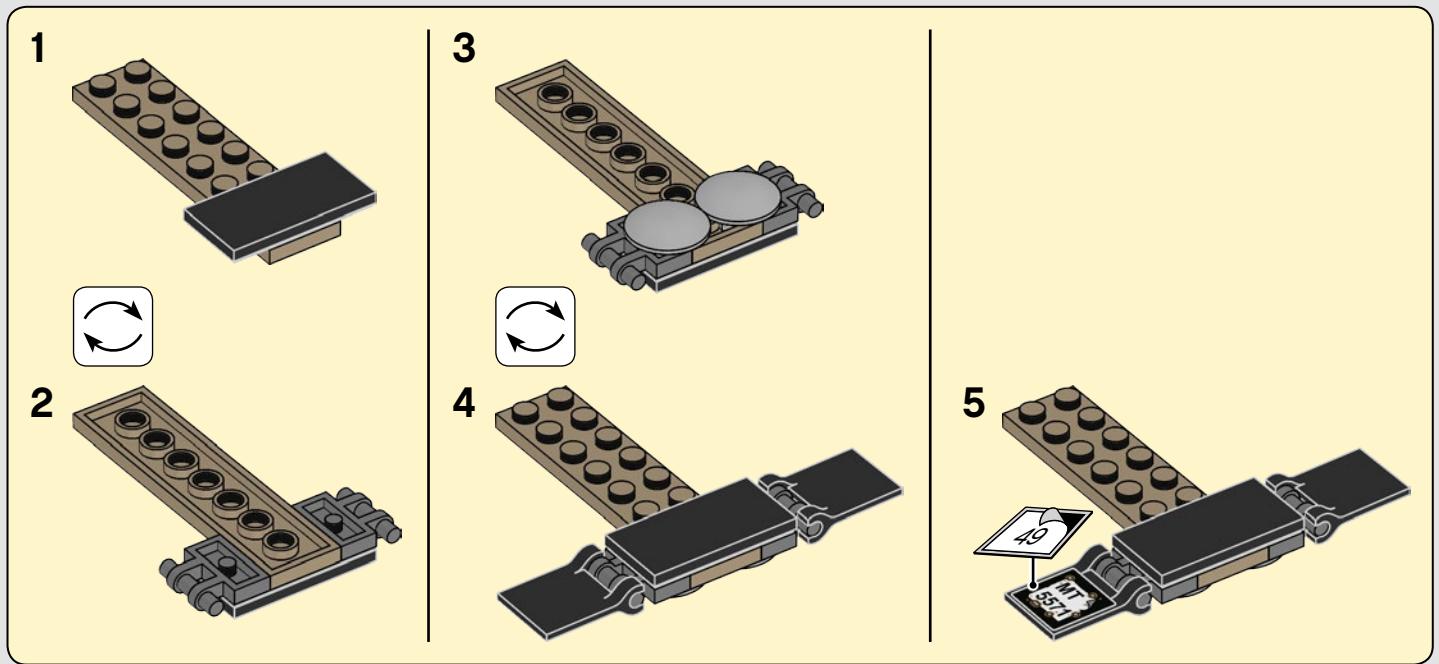



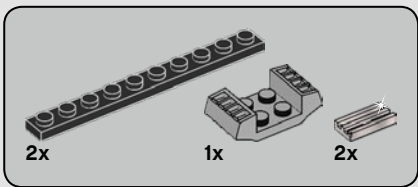

206

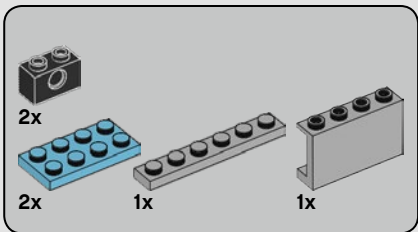
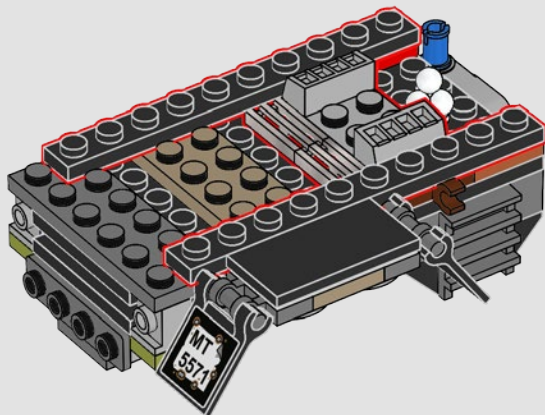

207

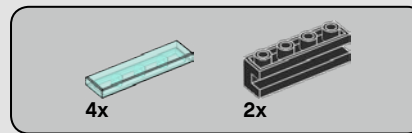
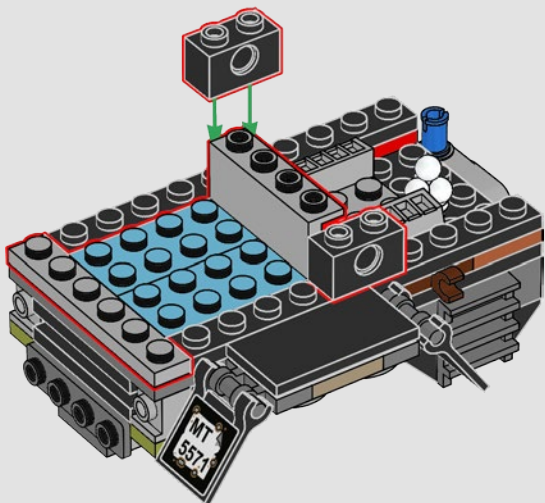

208

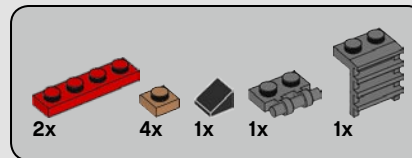
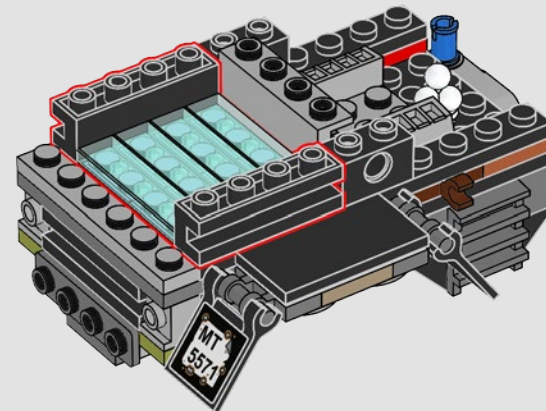

209

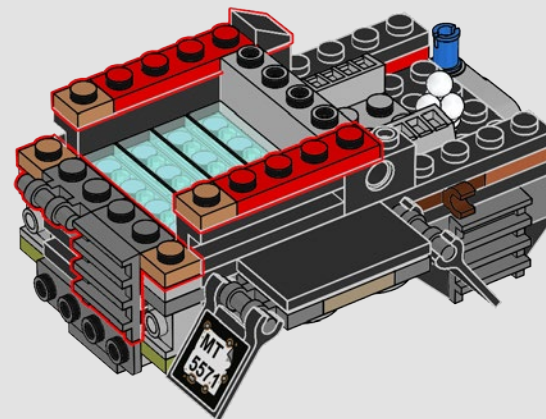

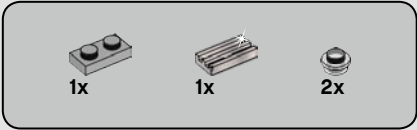

# 210

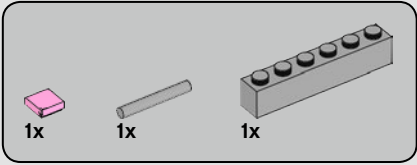
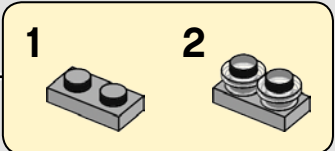
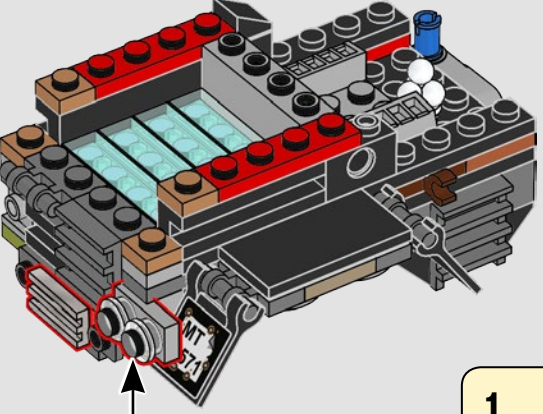

# 211

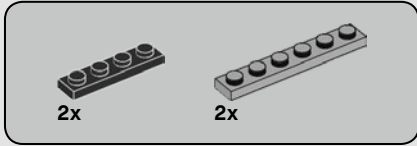
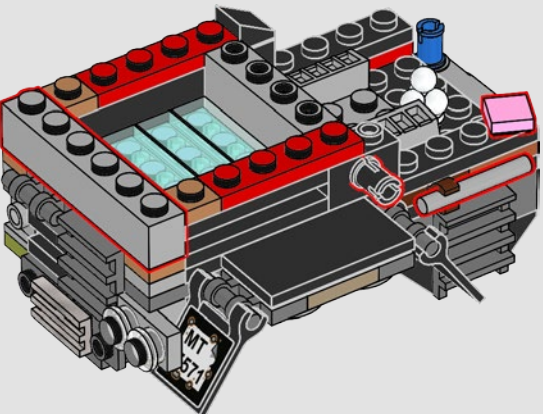

# 212

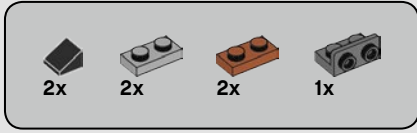
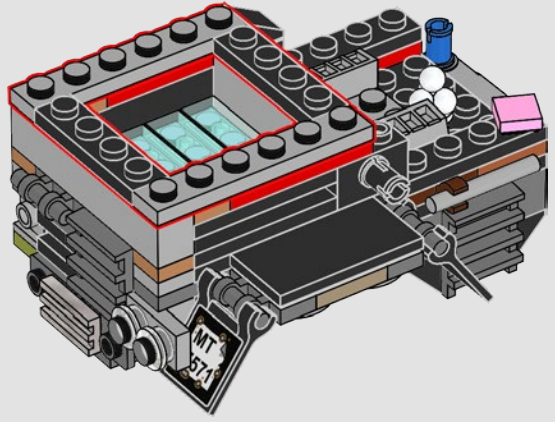

# 213

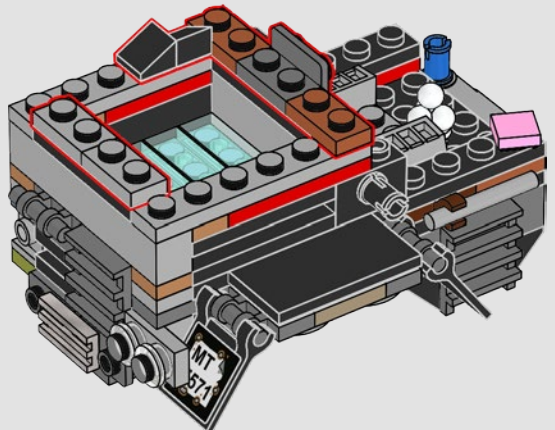

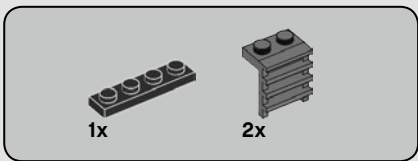

214

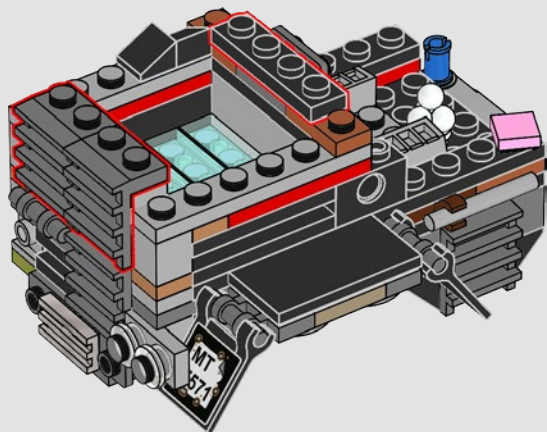

215

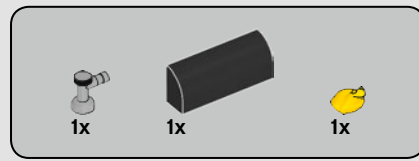
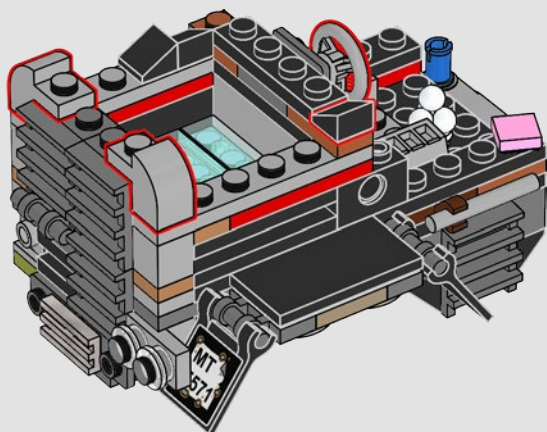

216

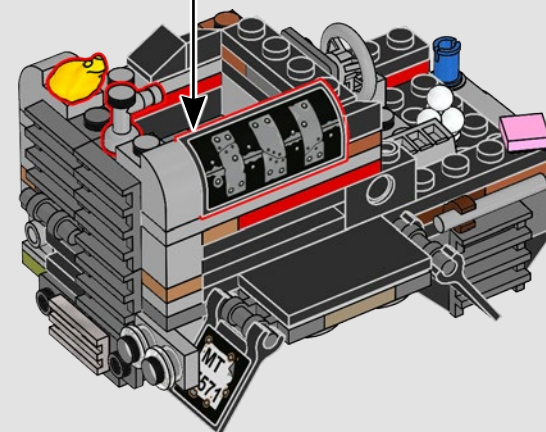
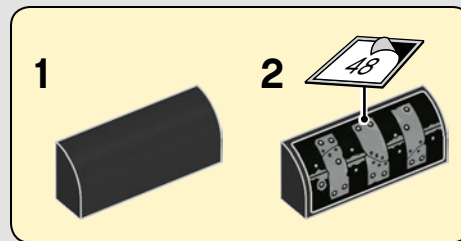

217

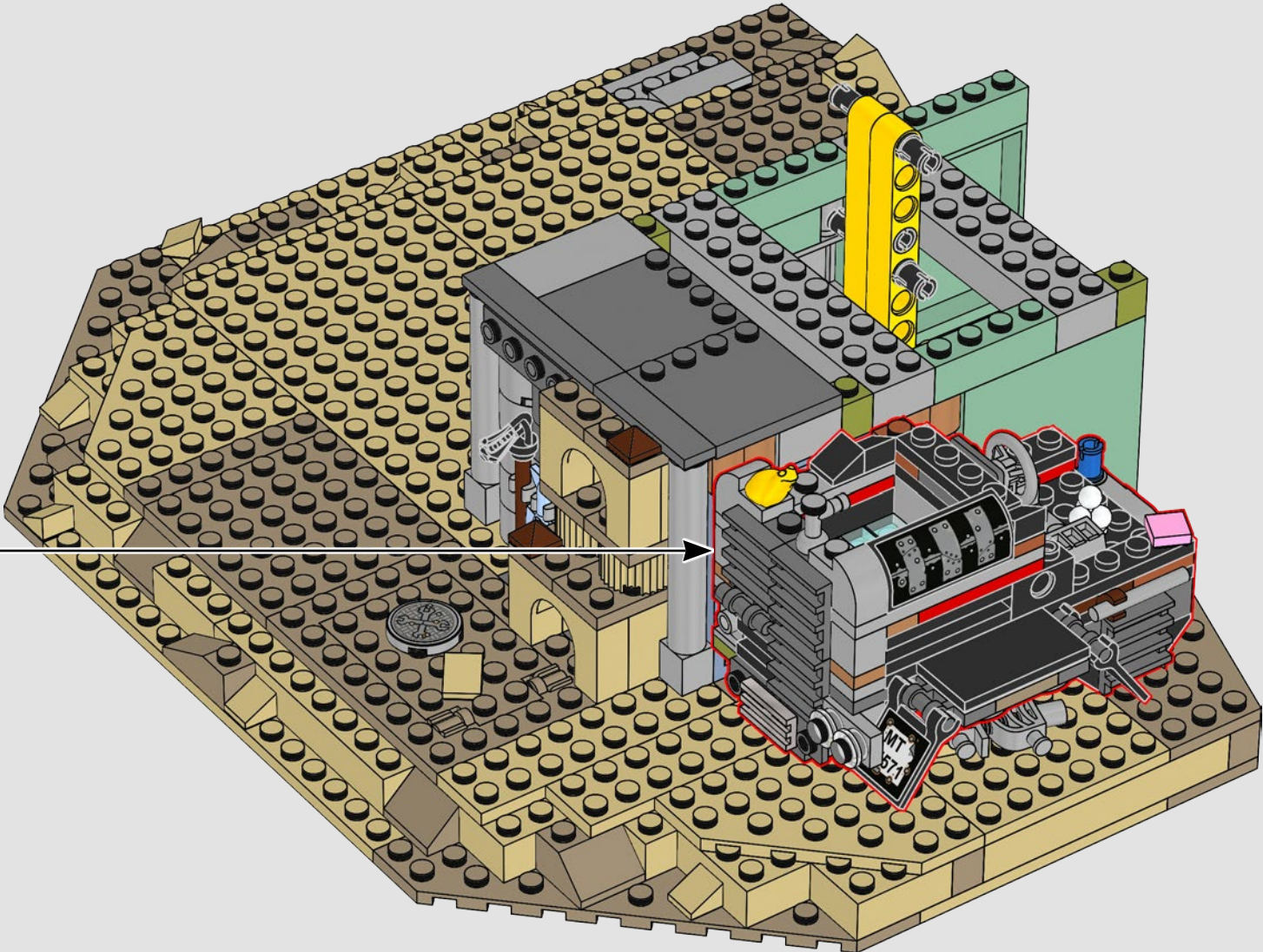

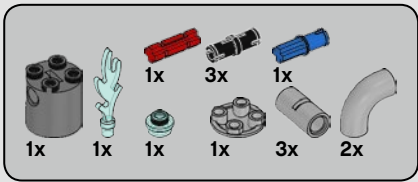

218

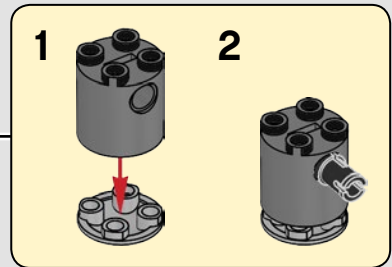
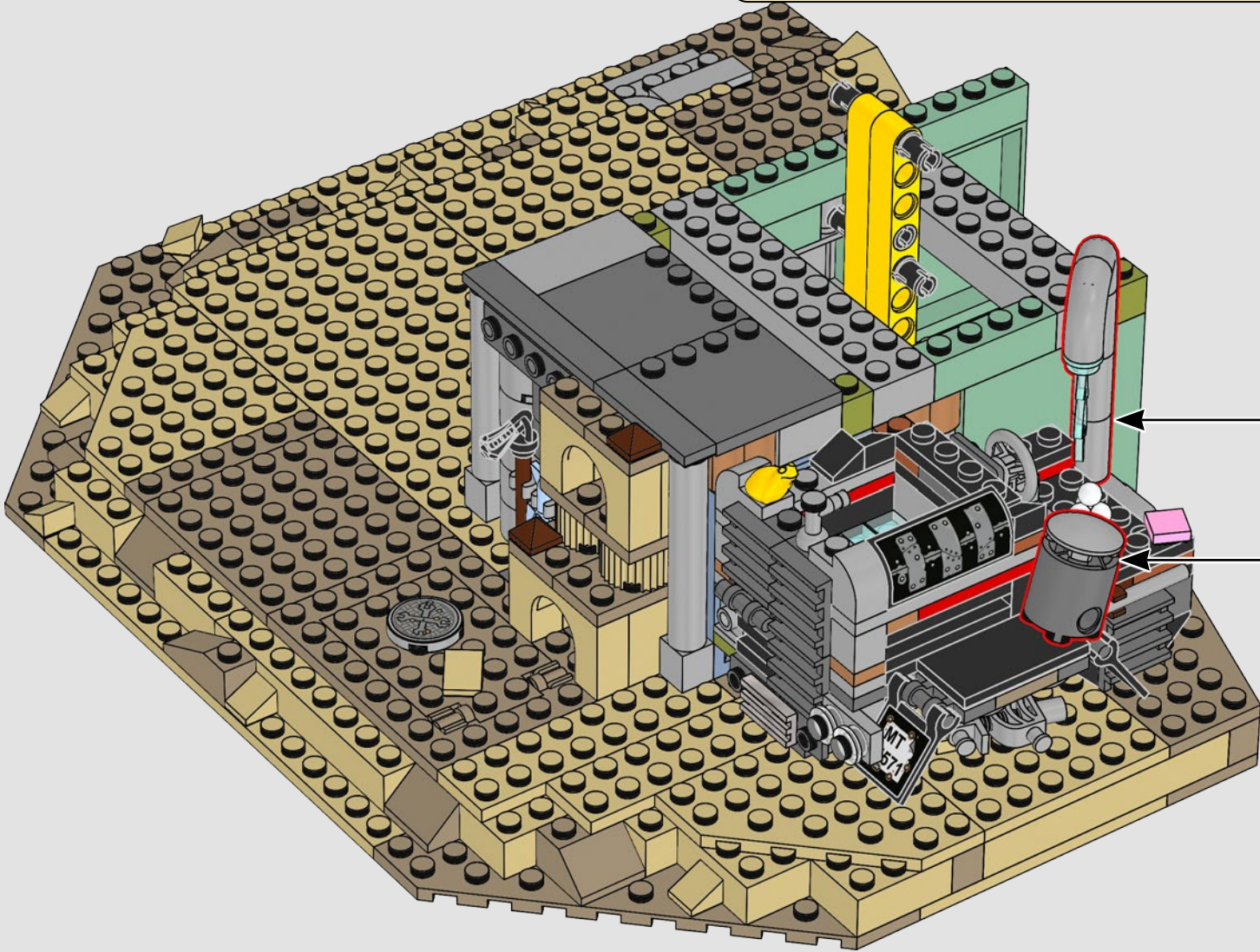
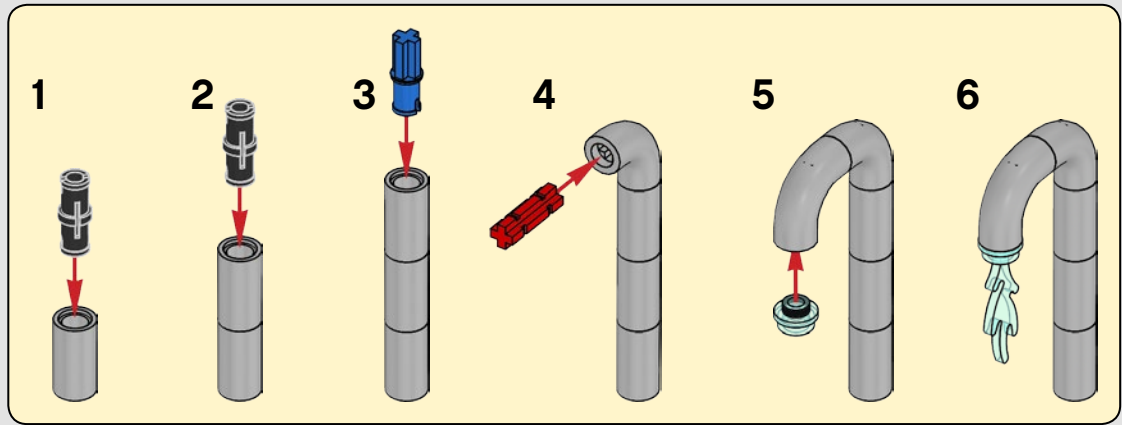

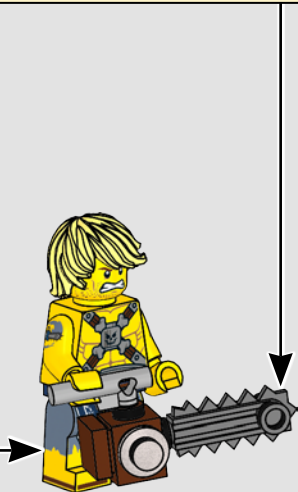
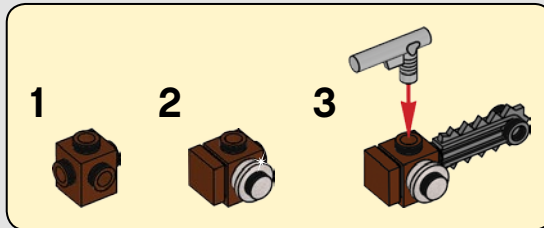
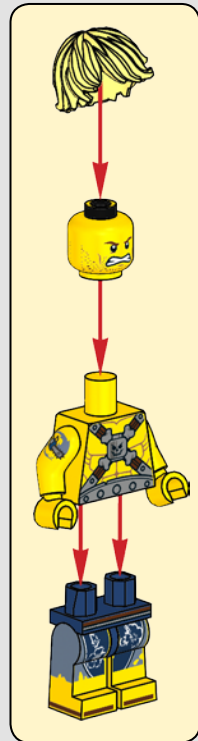
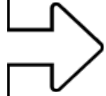

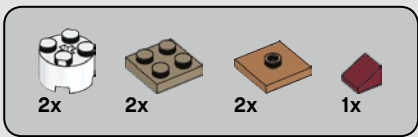

219

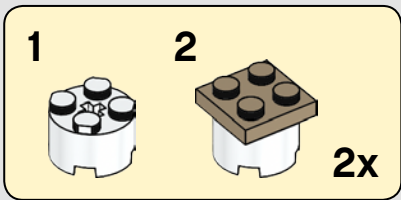
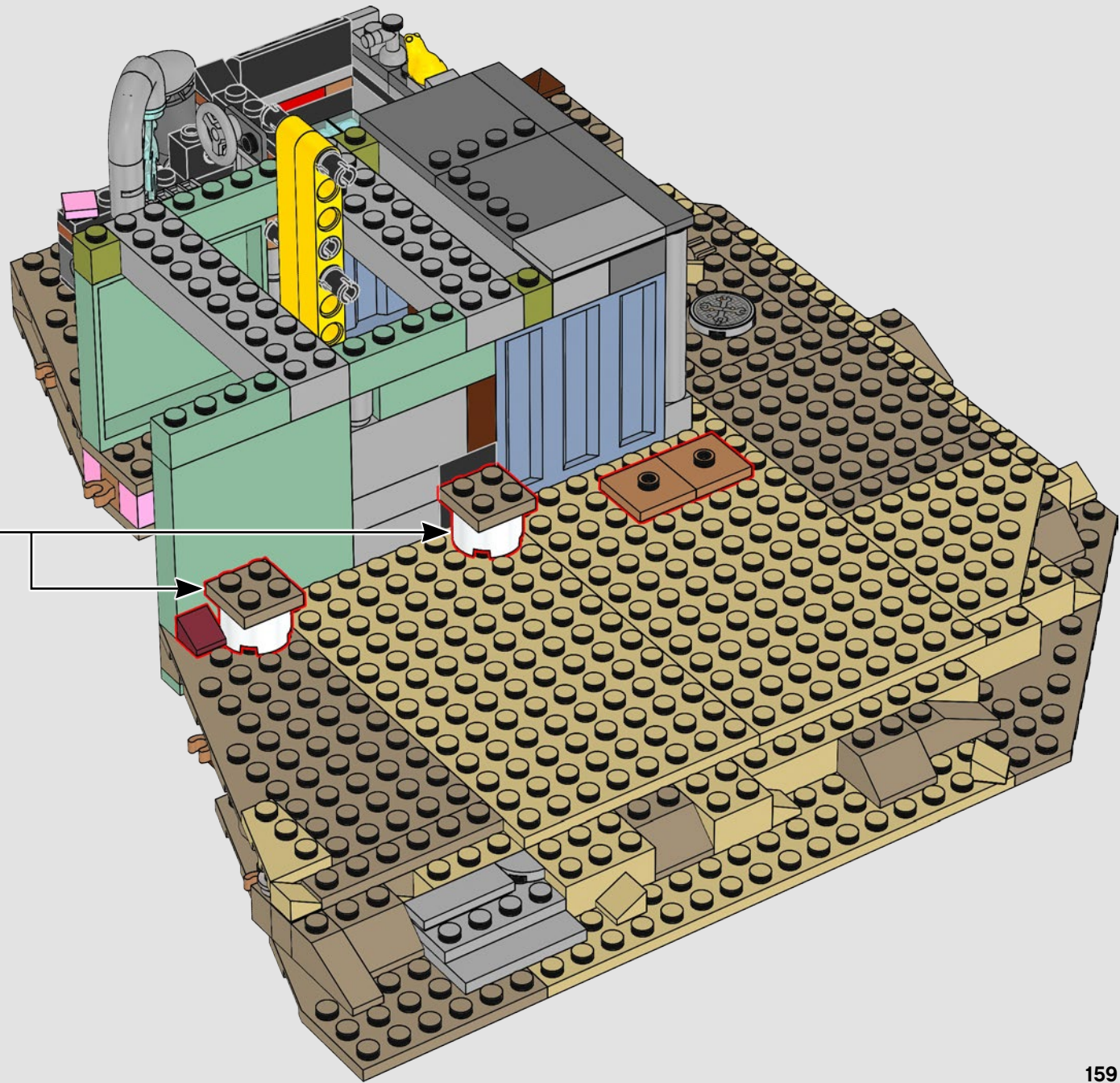
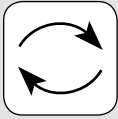

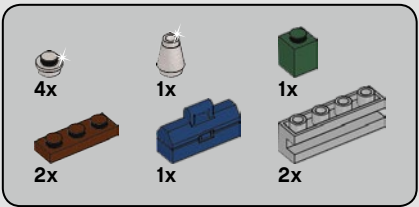

220

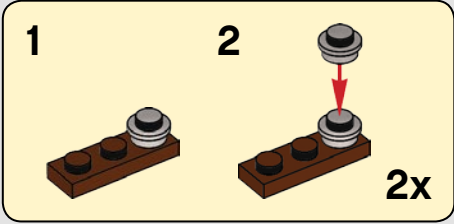
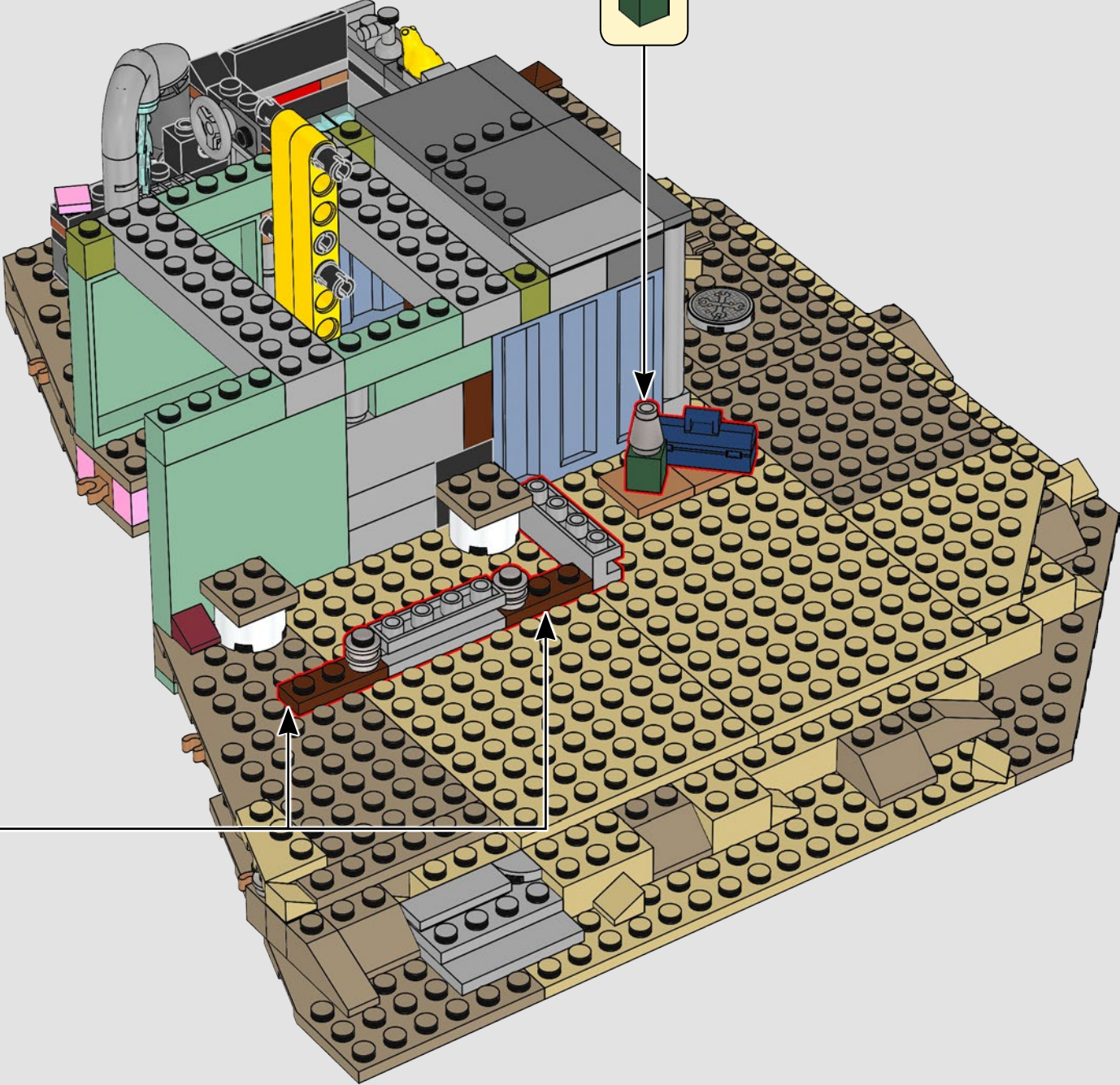
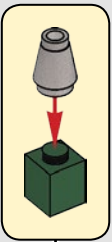



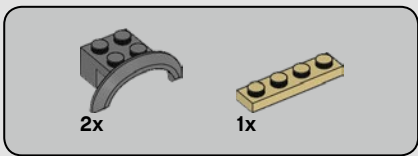

221

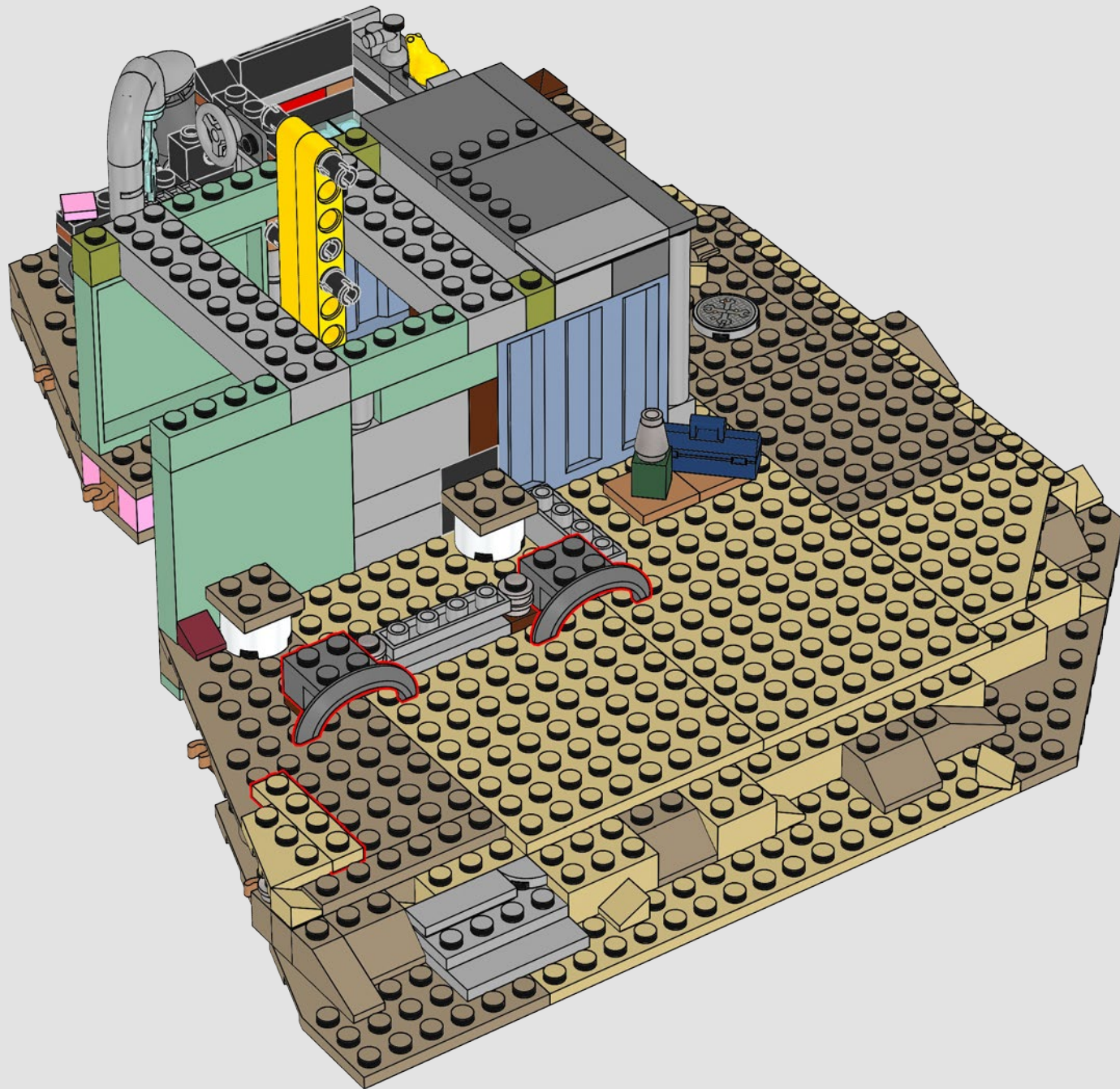

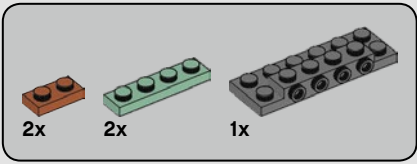



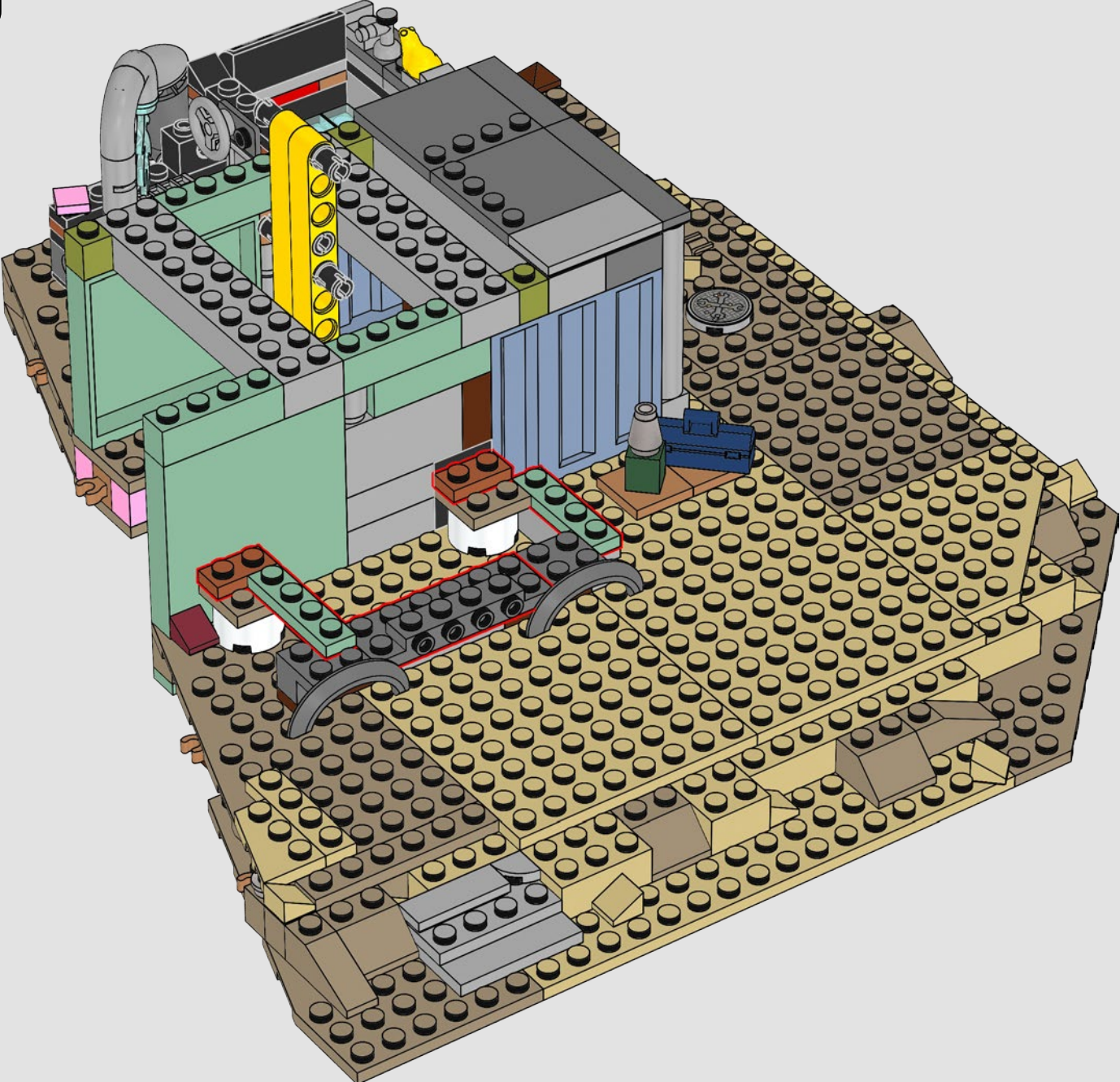

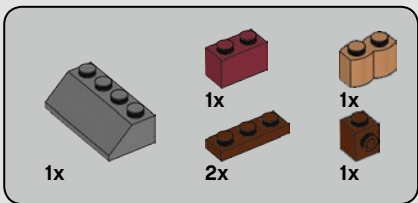
222



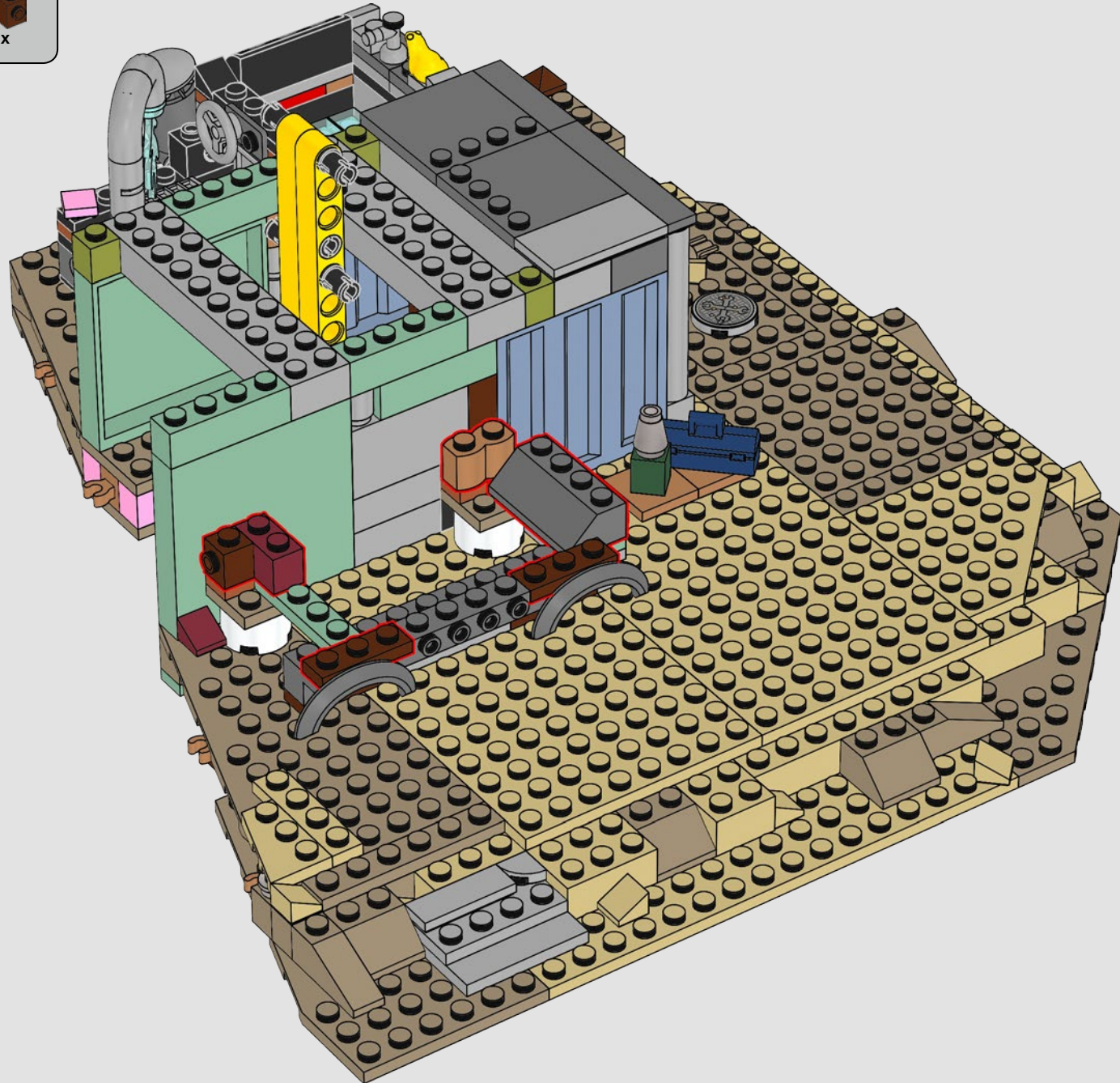

223



			
1x	4x	3x	2x

224

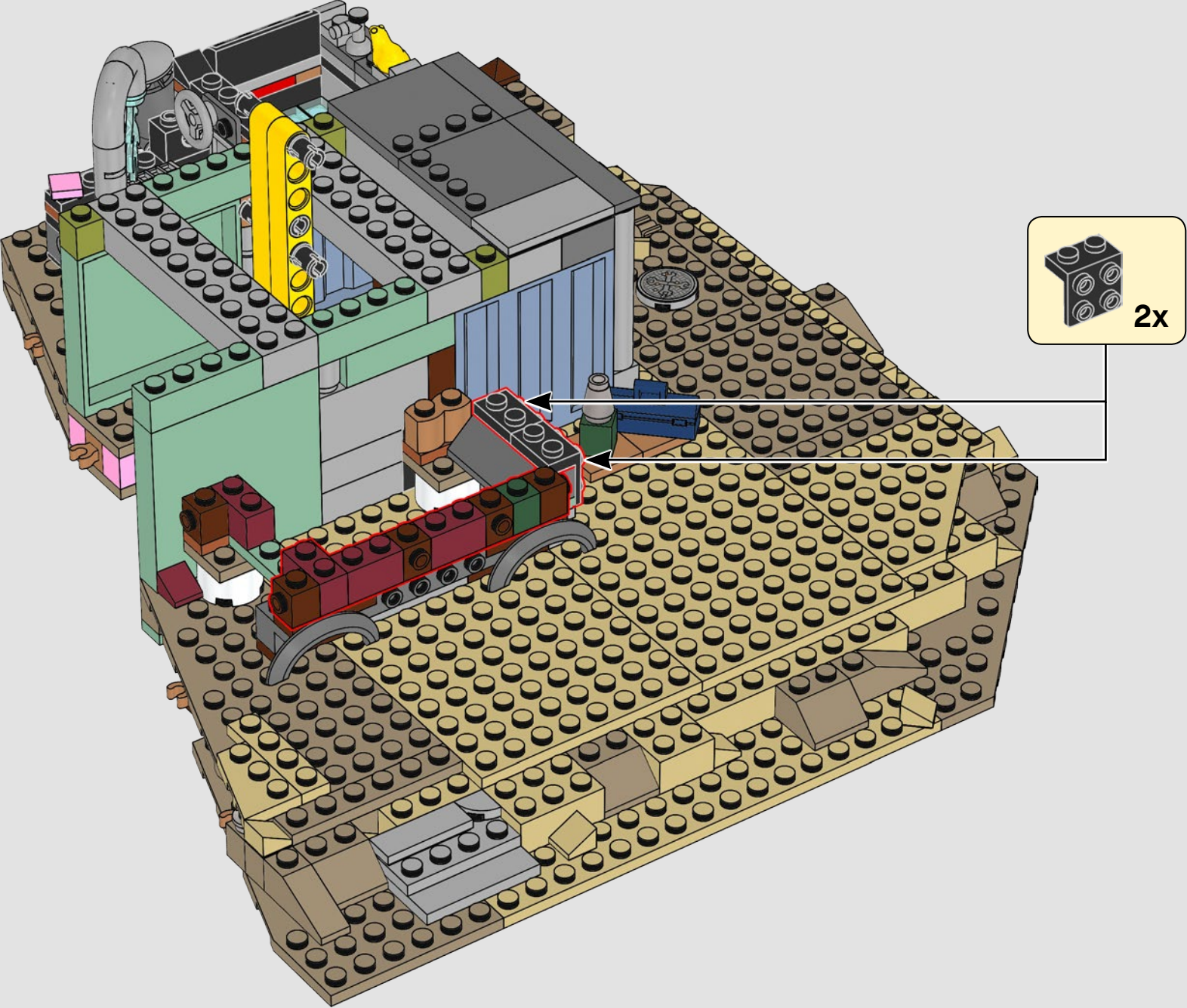

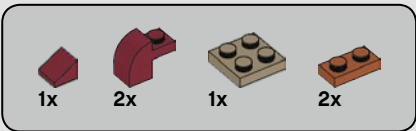

225

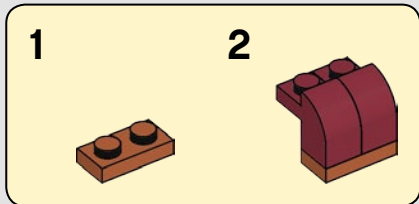
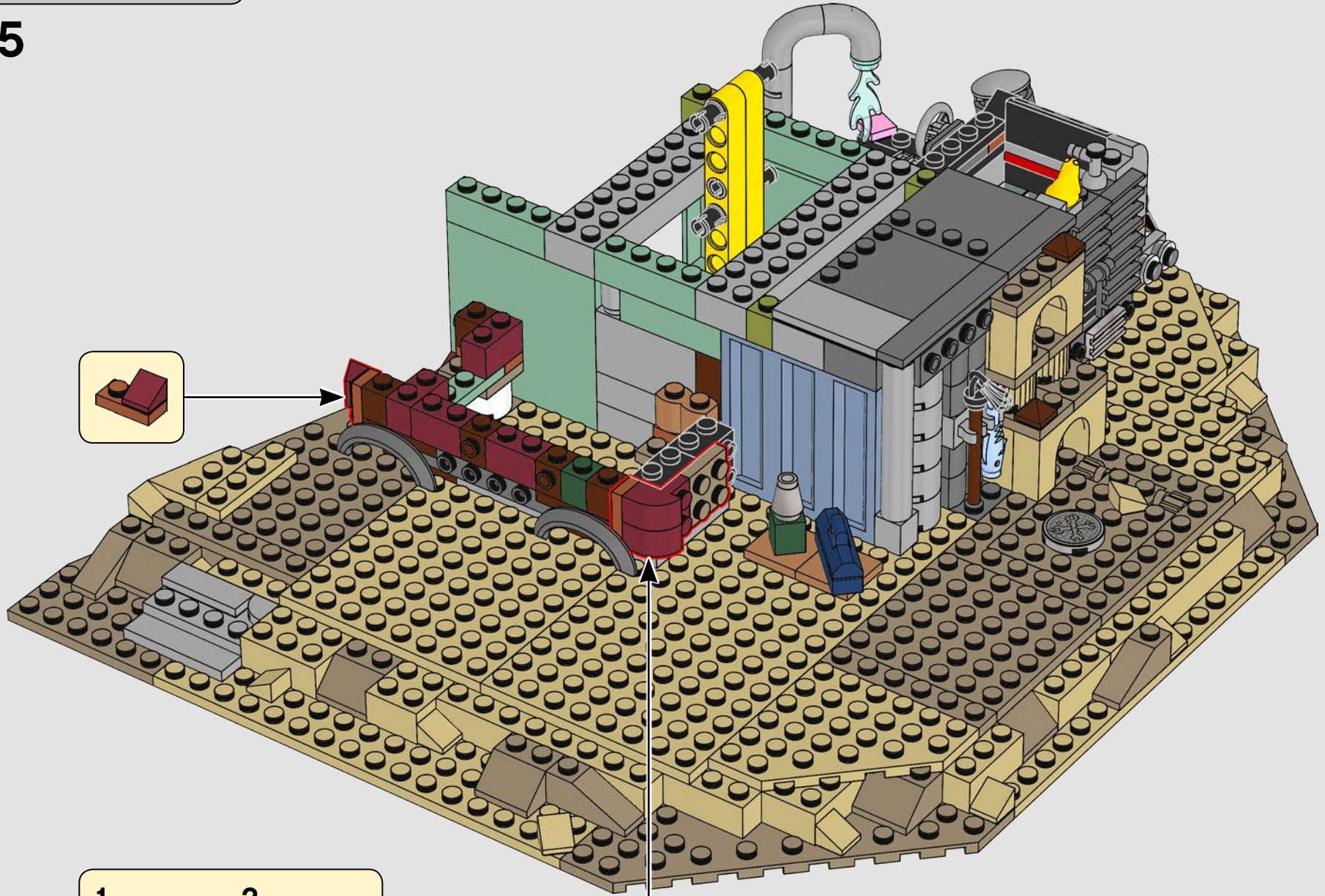

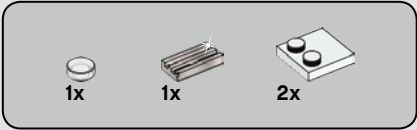

226

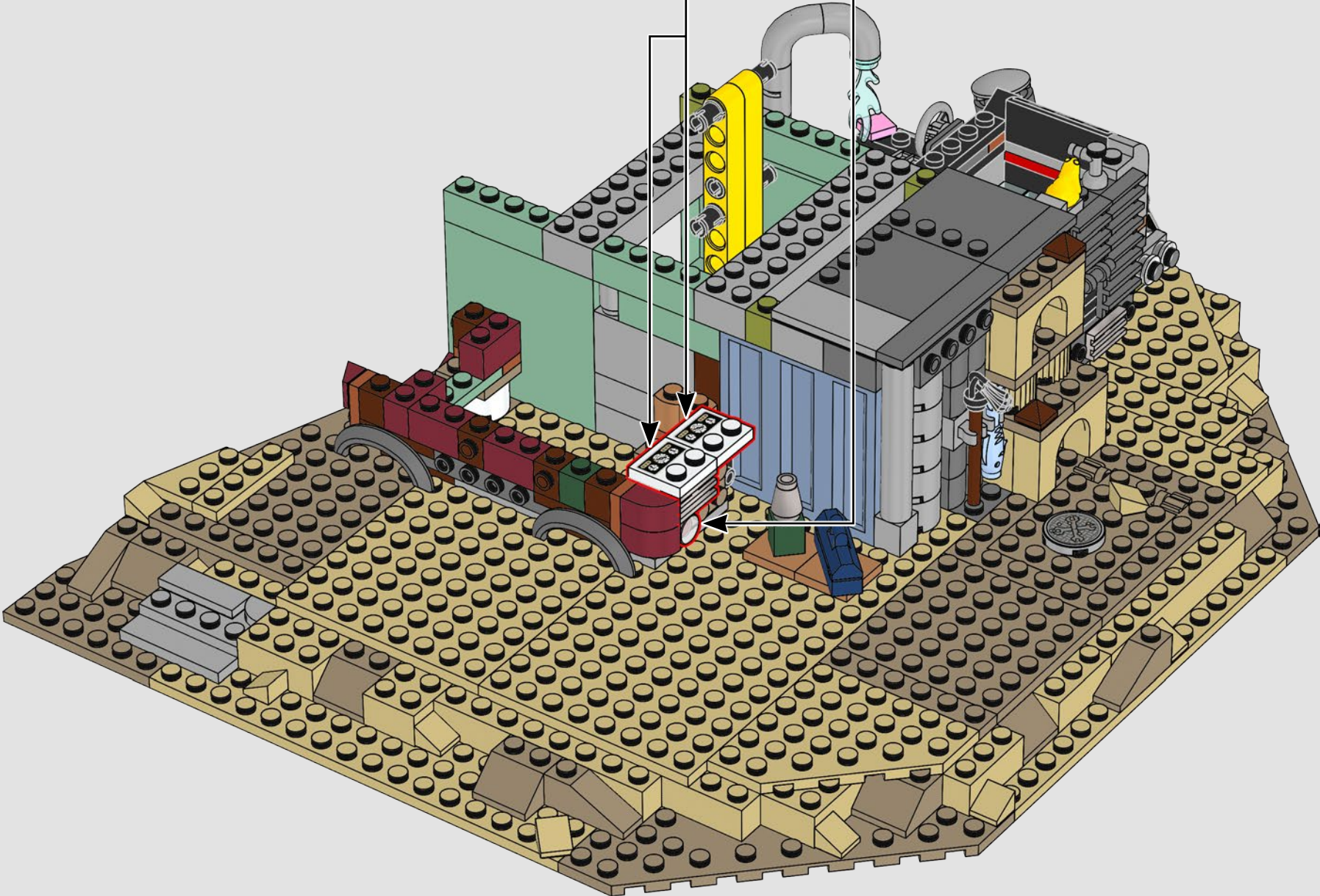
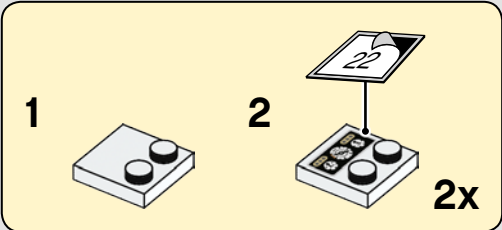

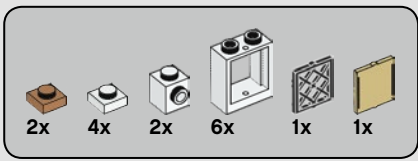

227

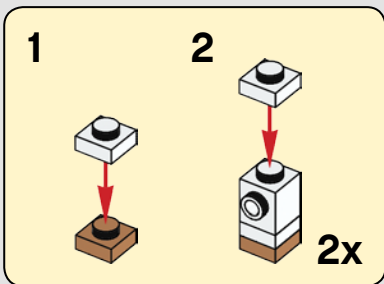
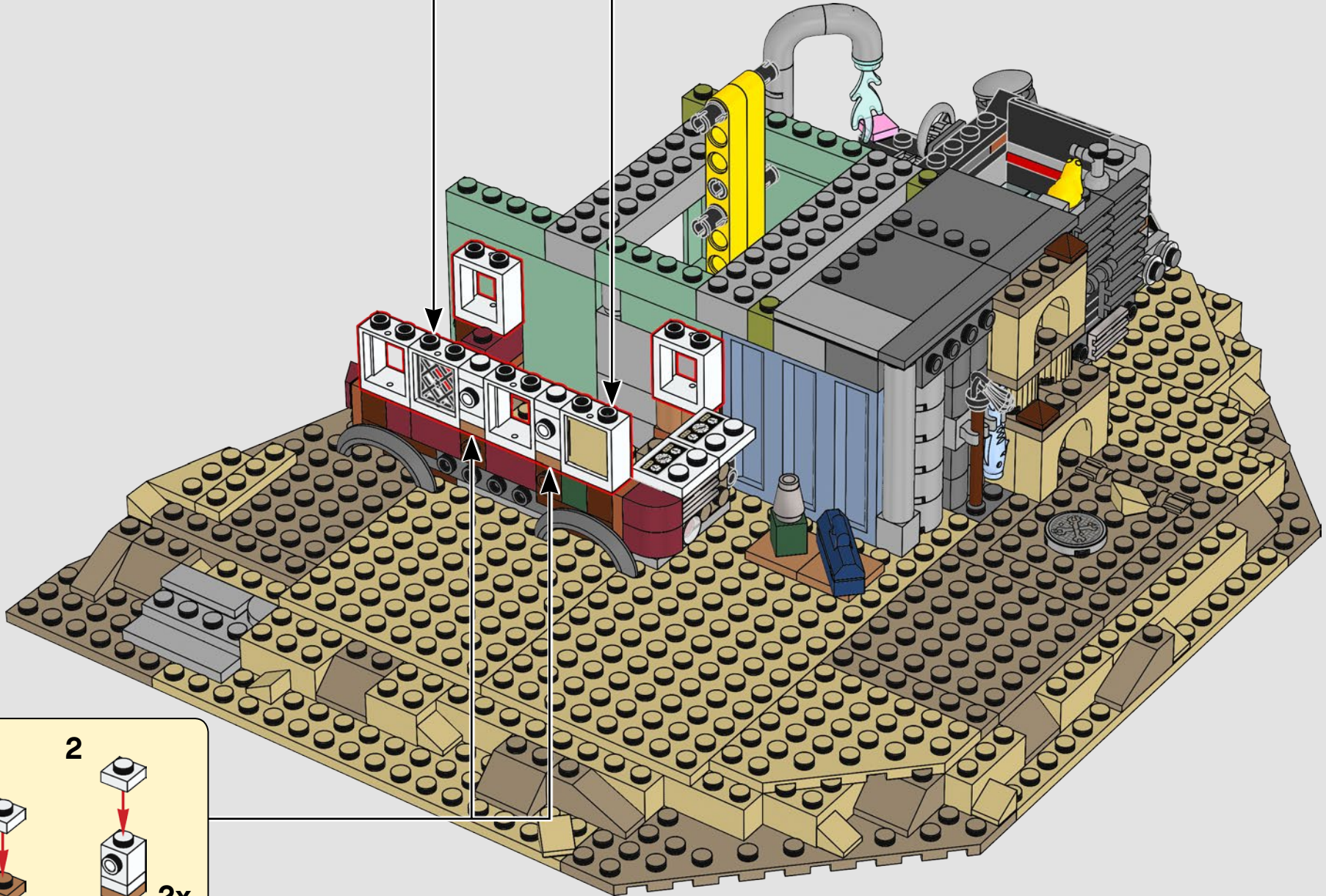
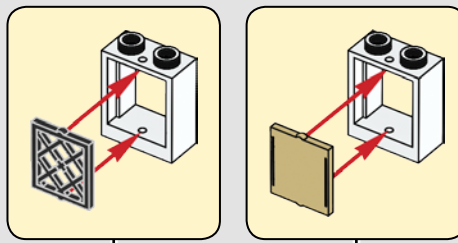

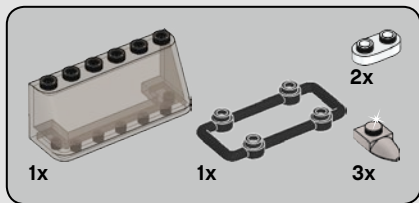

228

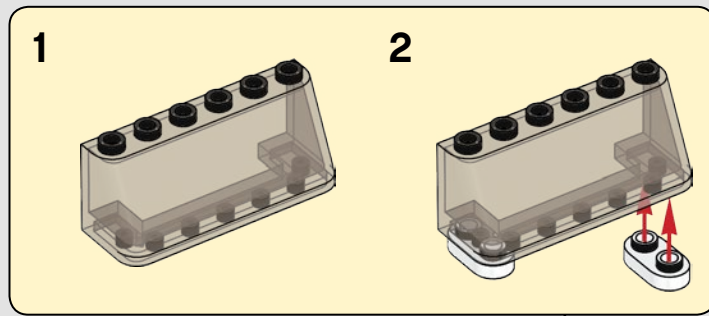



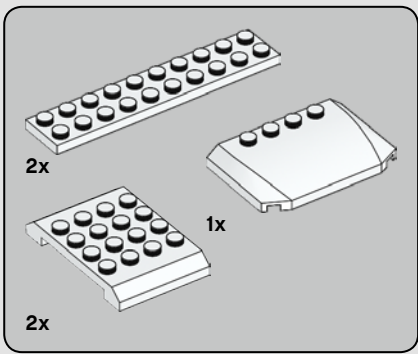

229

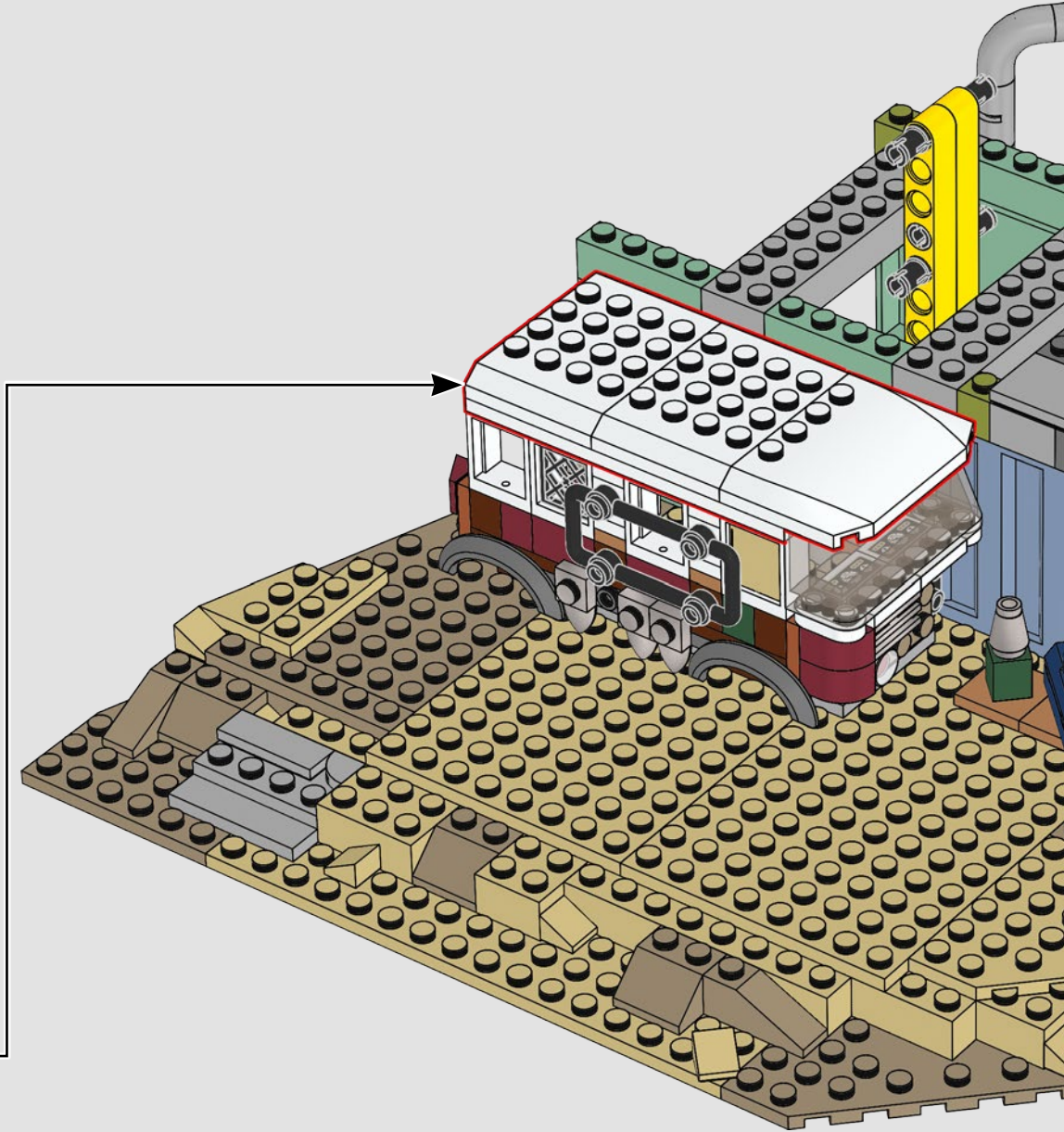
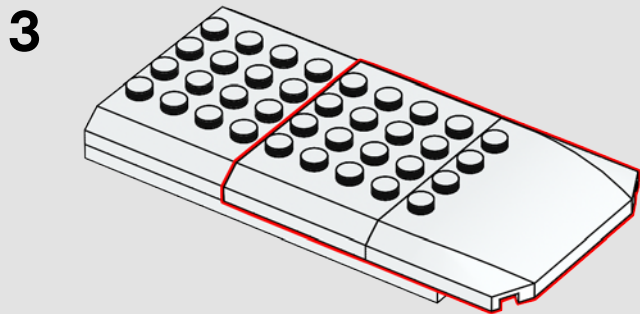
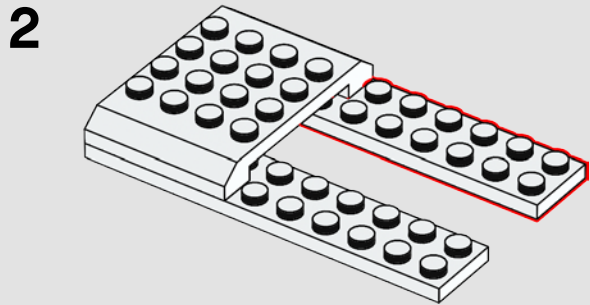
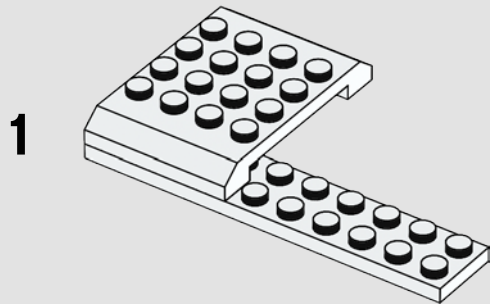

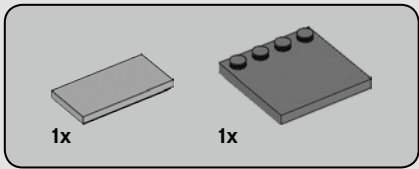

230



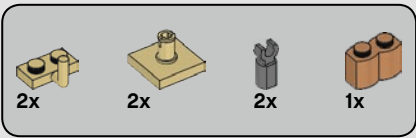

# 231

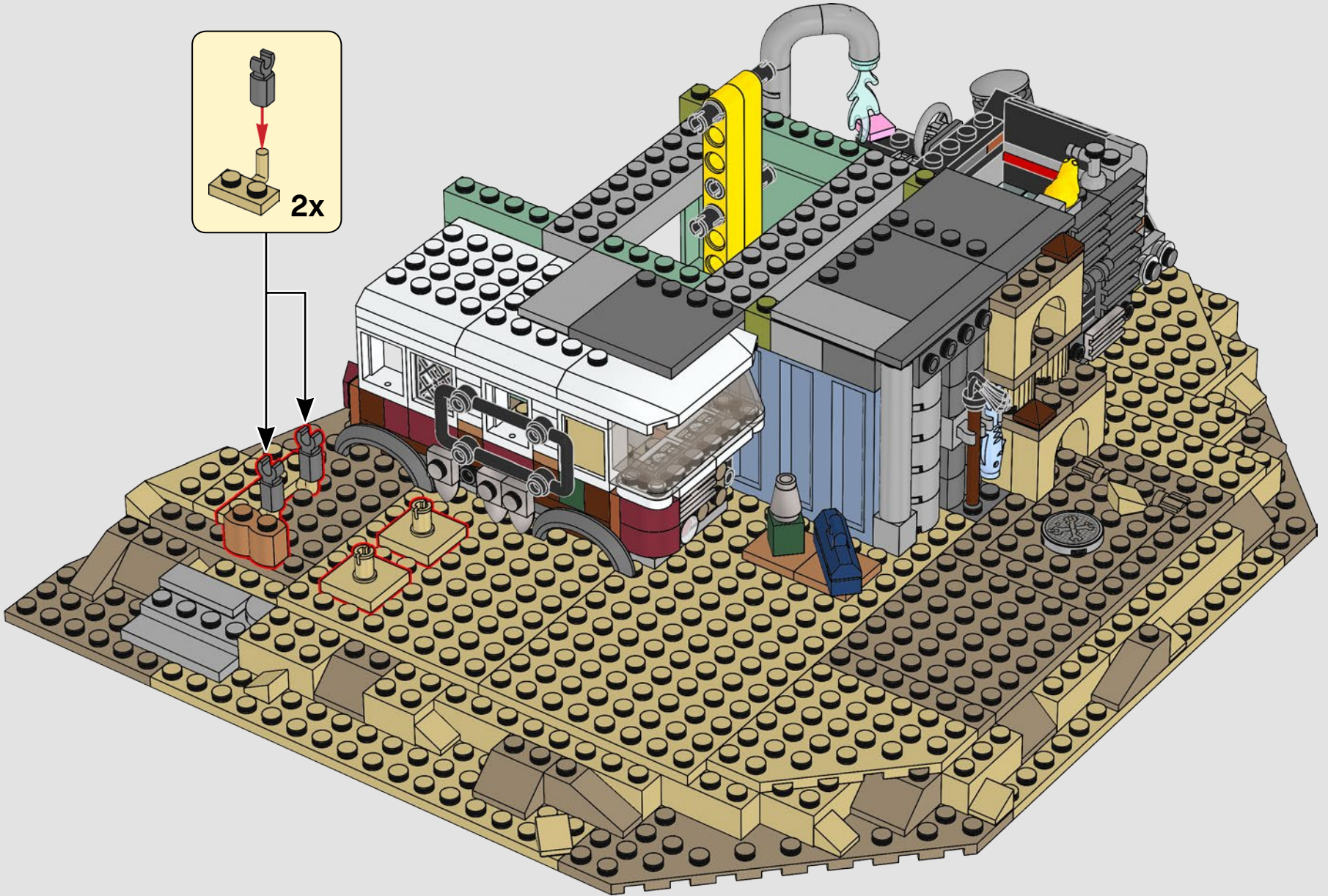
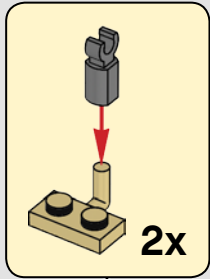

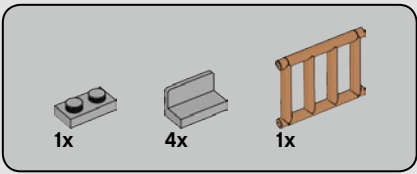

232

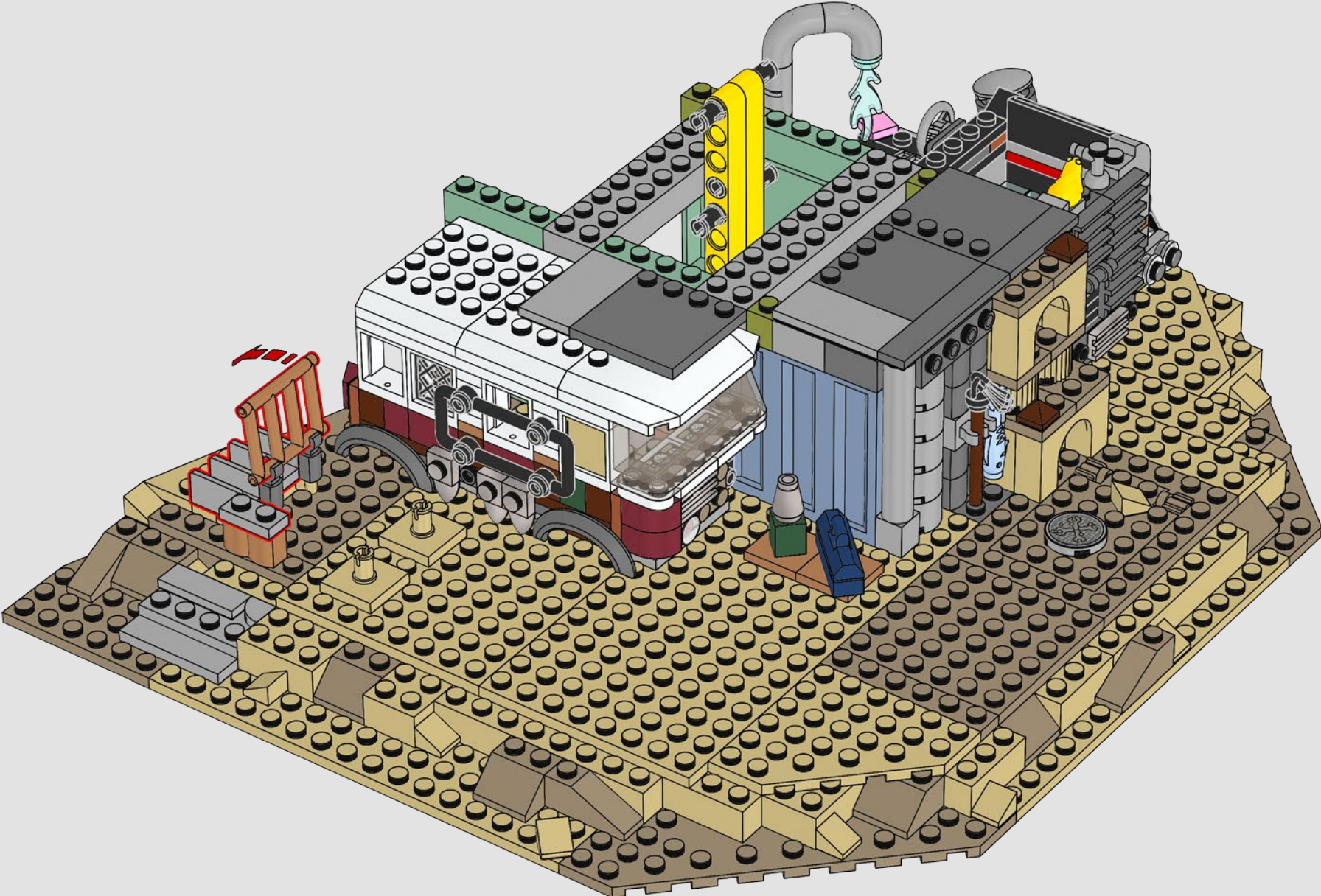

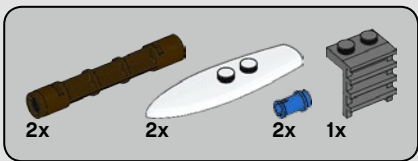

233

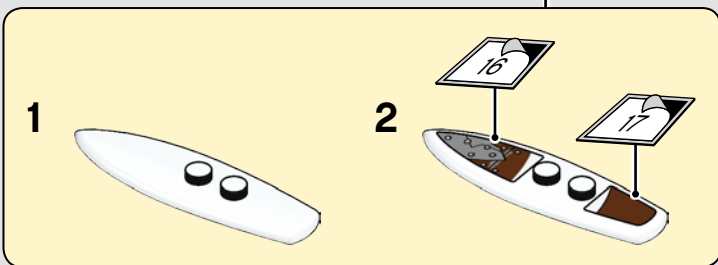
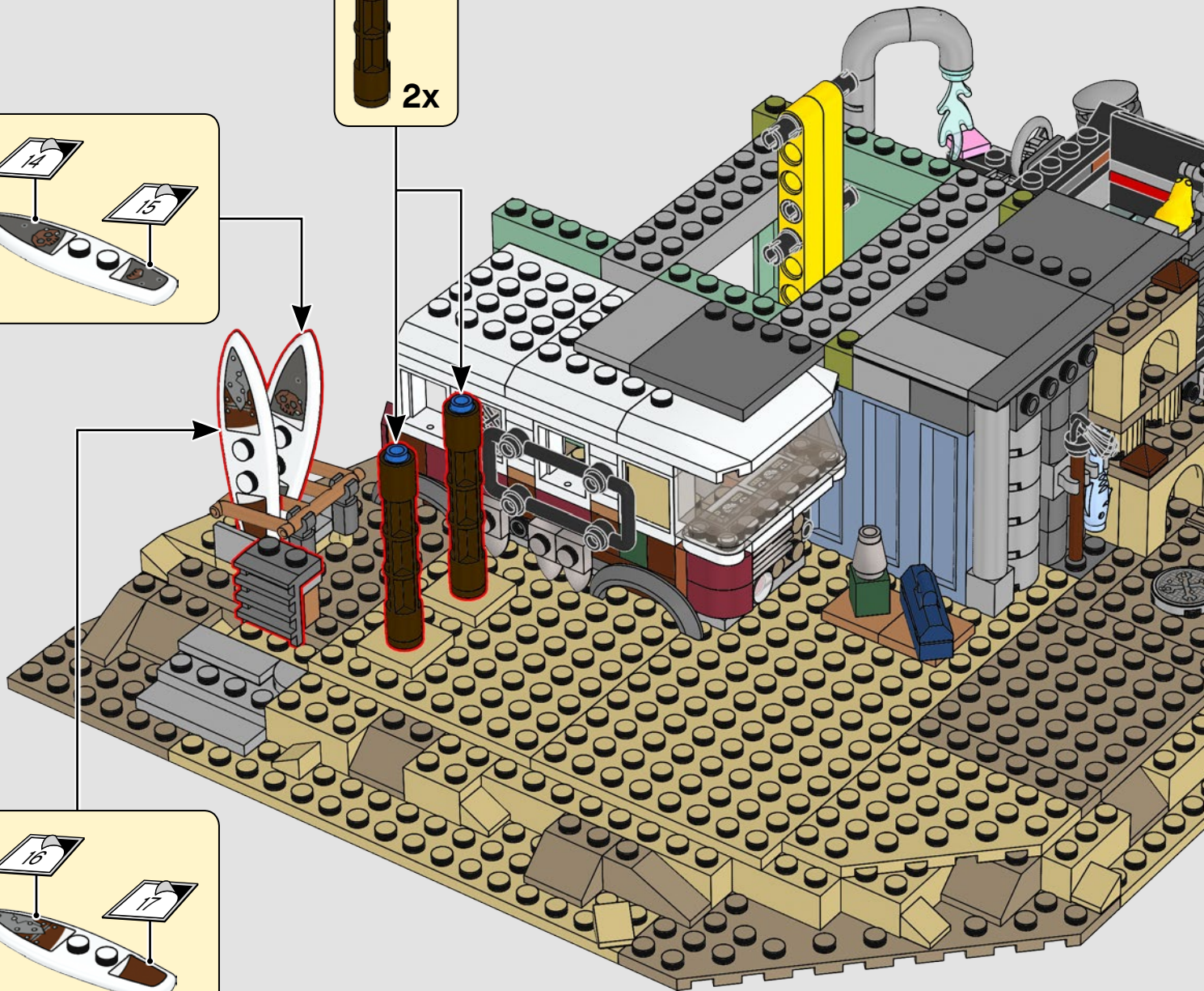
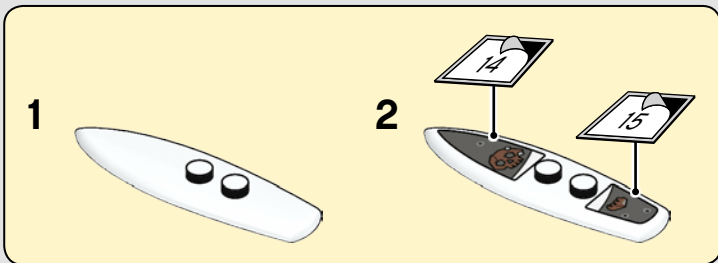
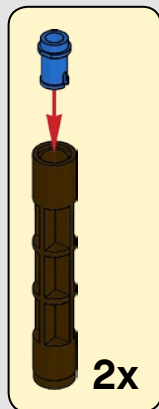

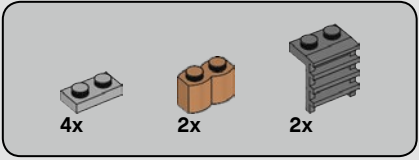

234

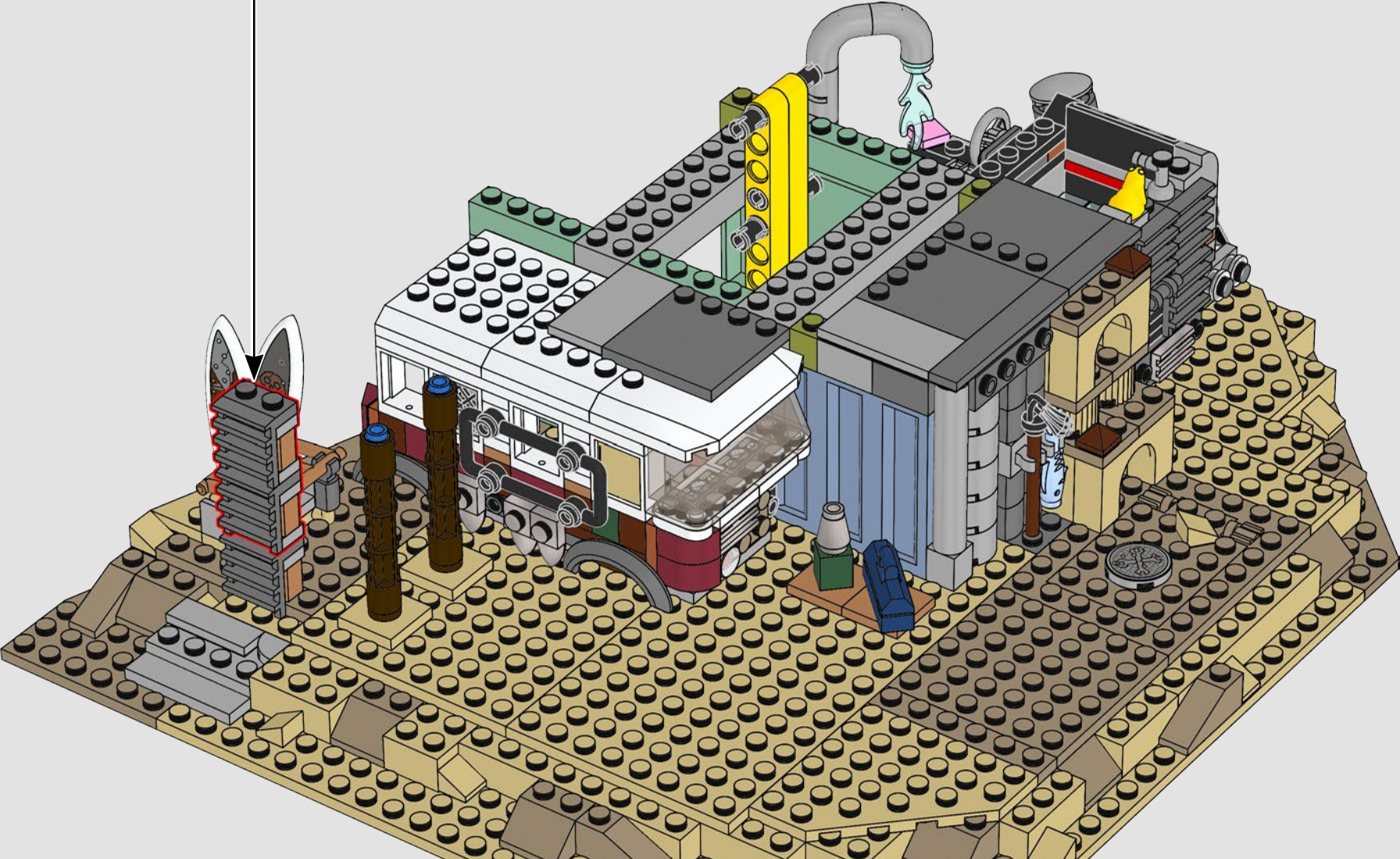
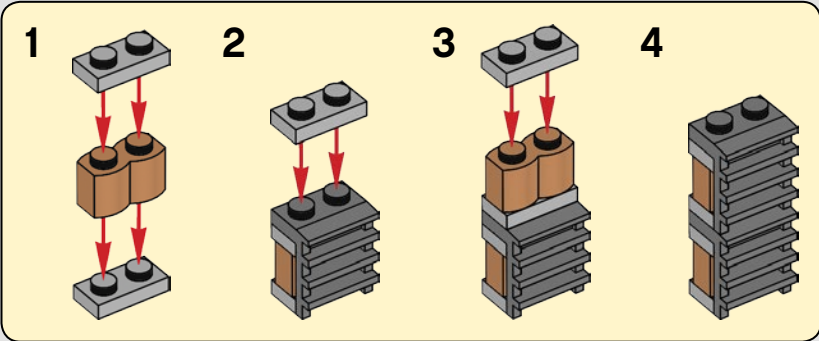

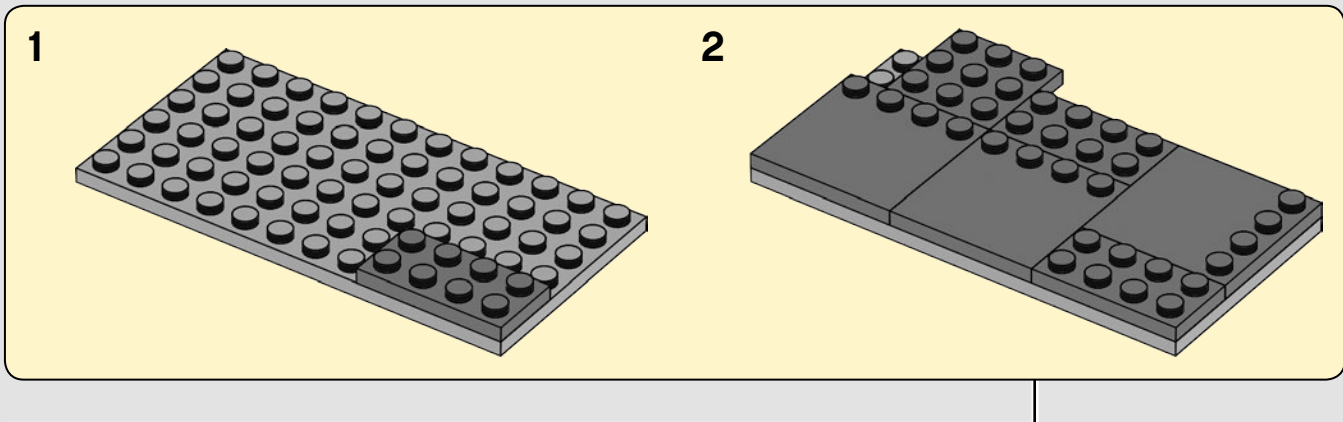
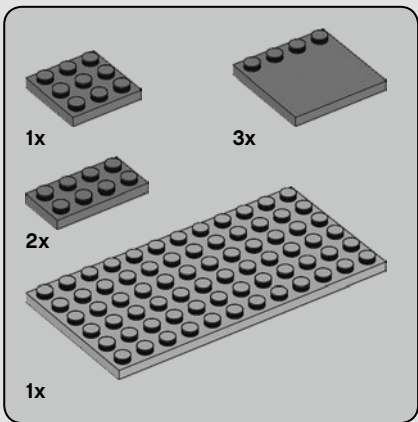

235

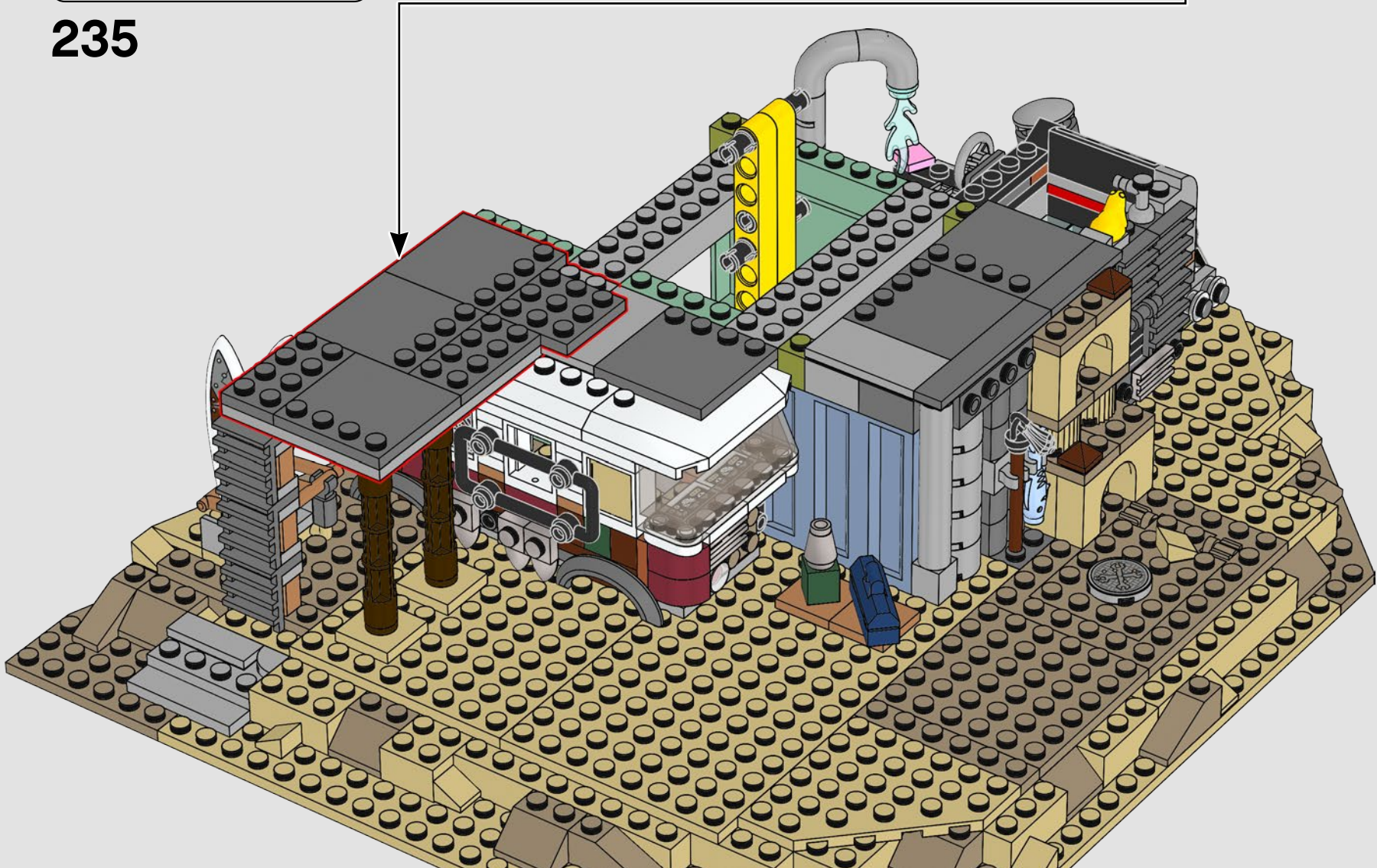

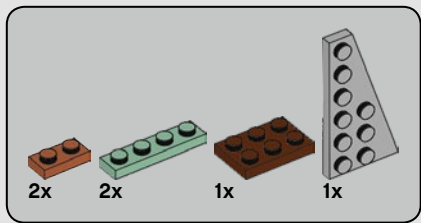

236

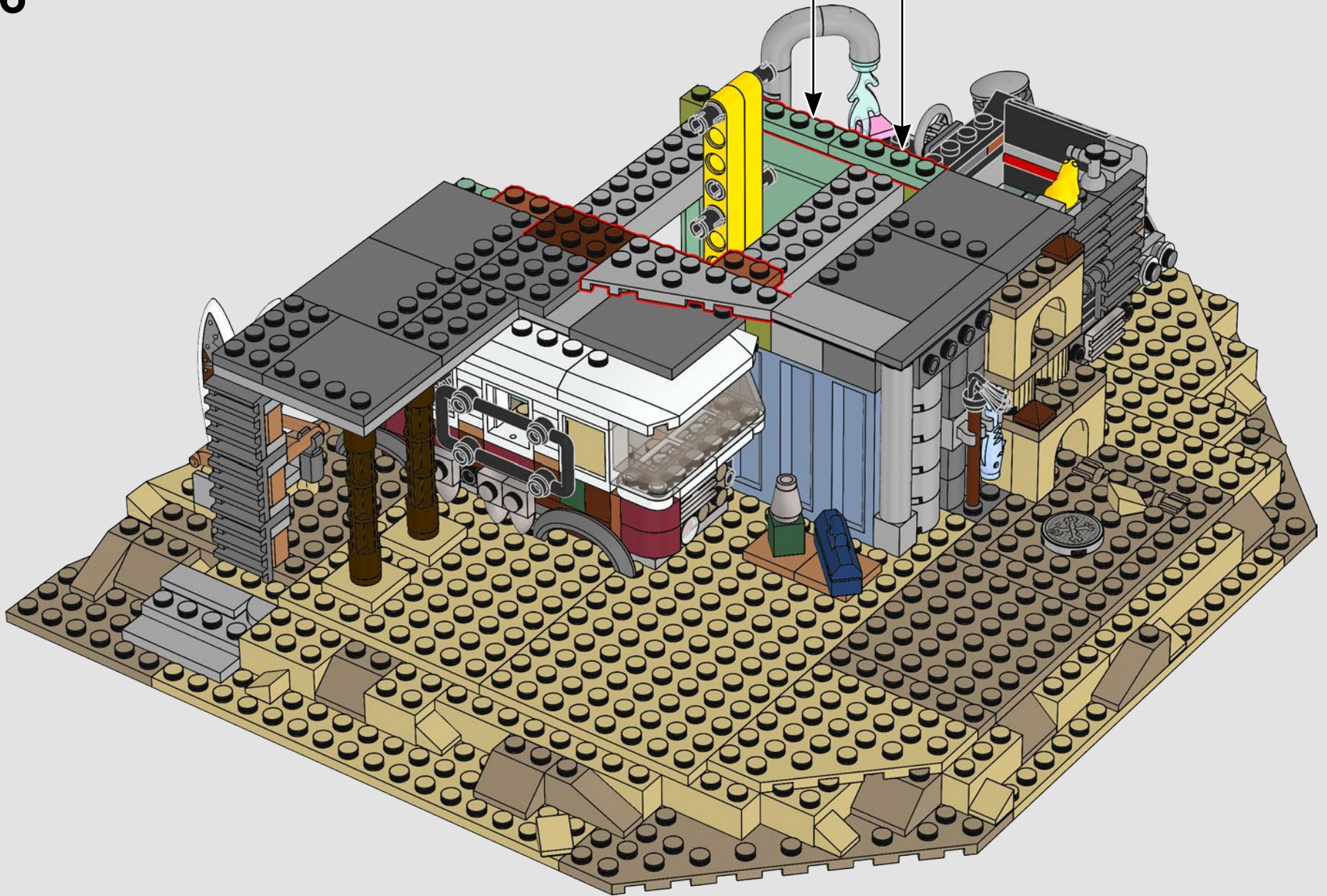
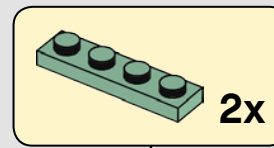



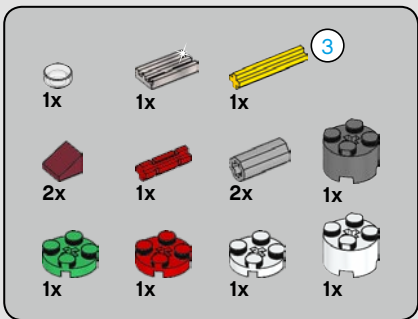

237

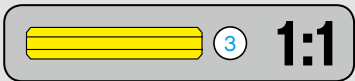
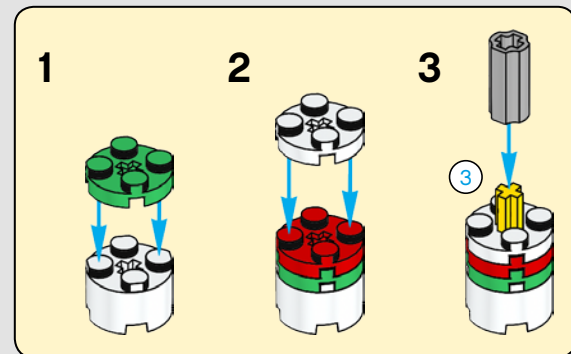
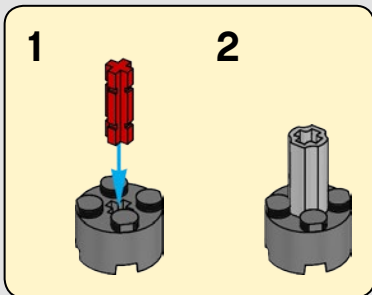

238

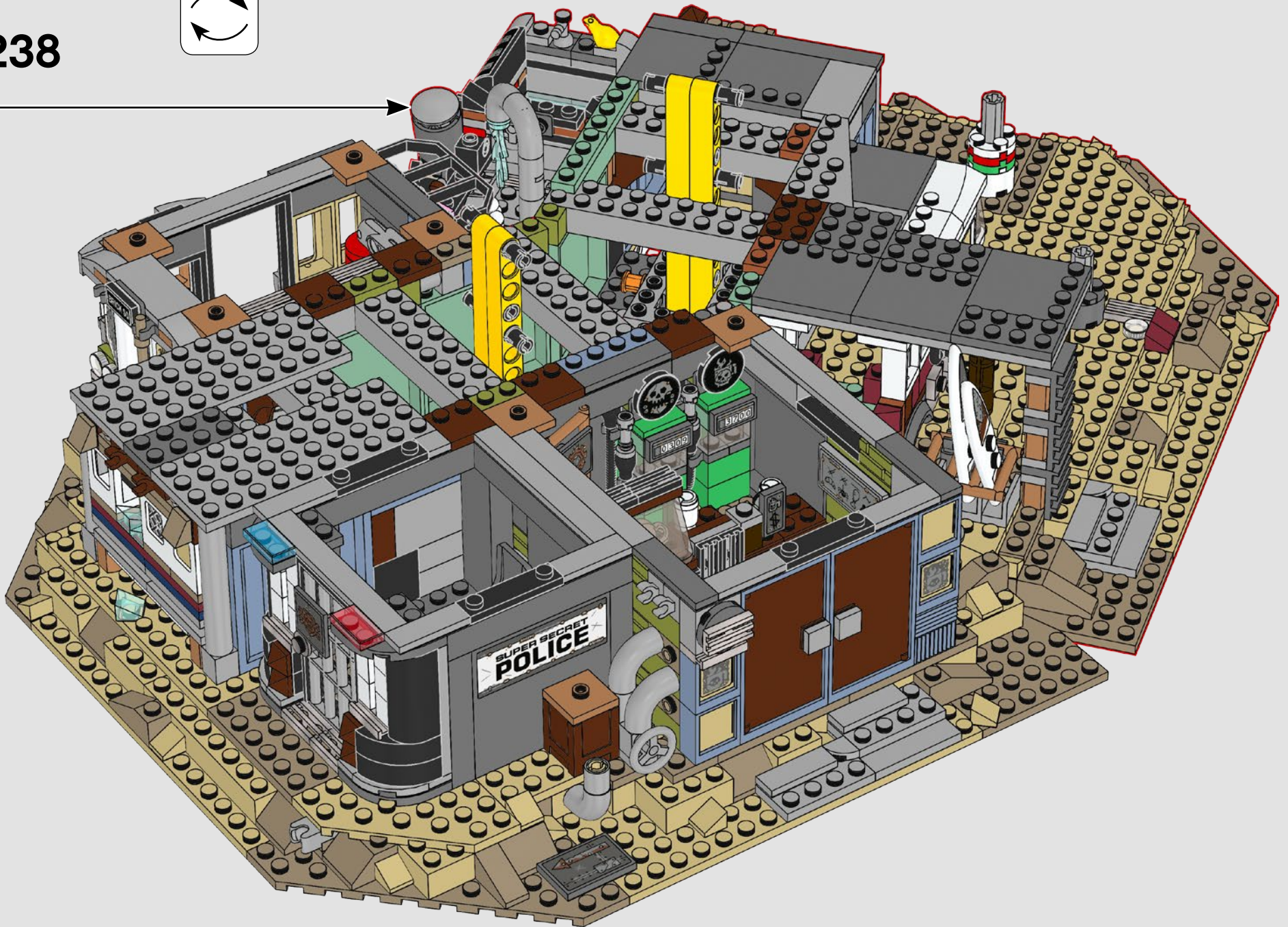
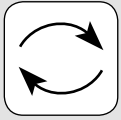

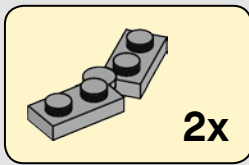
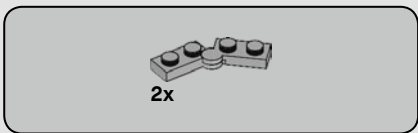

239



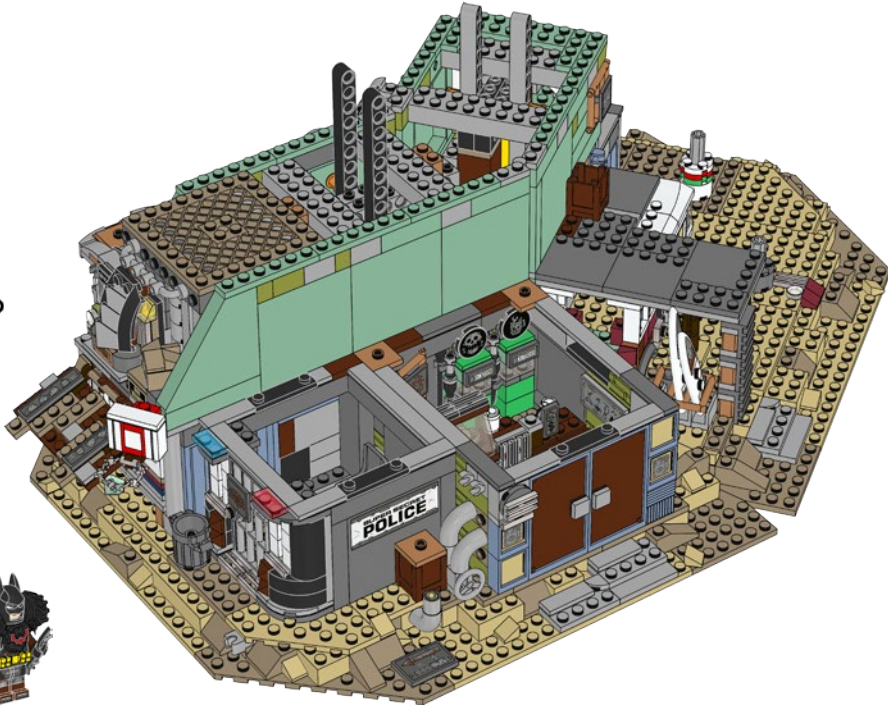
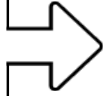

1

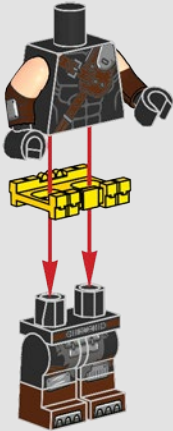

2



3



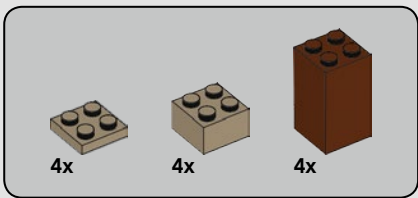

240

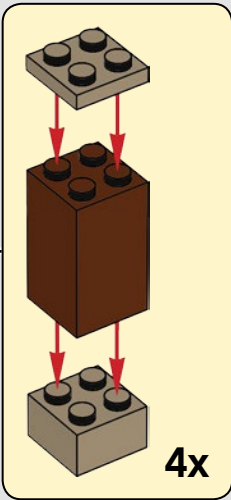
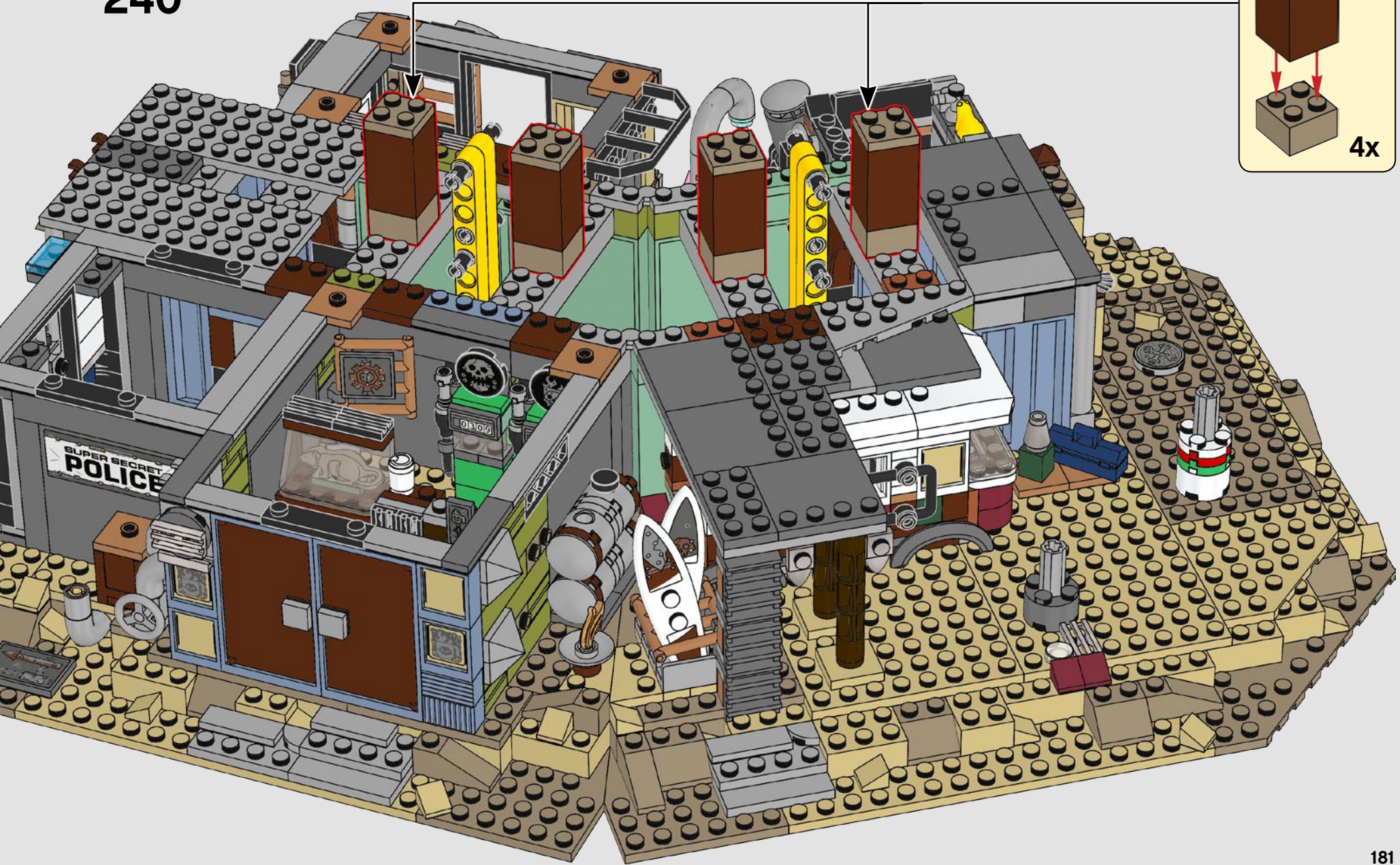

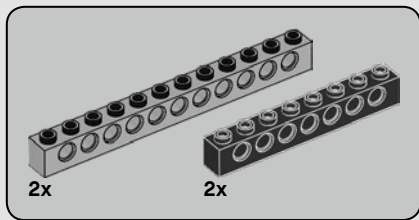

241

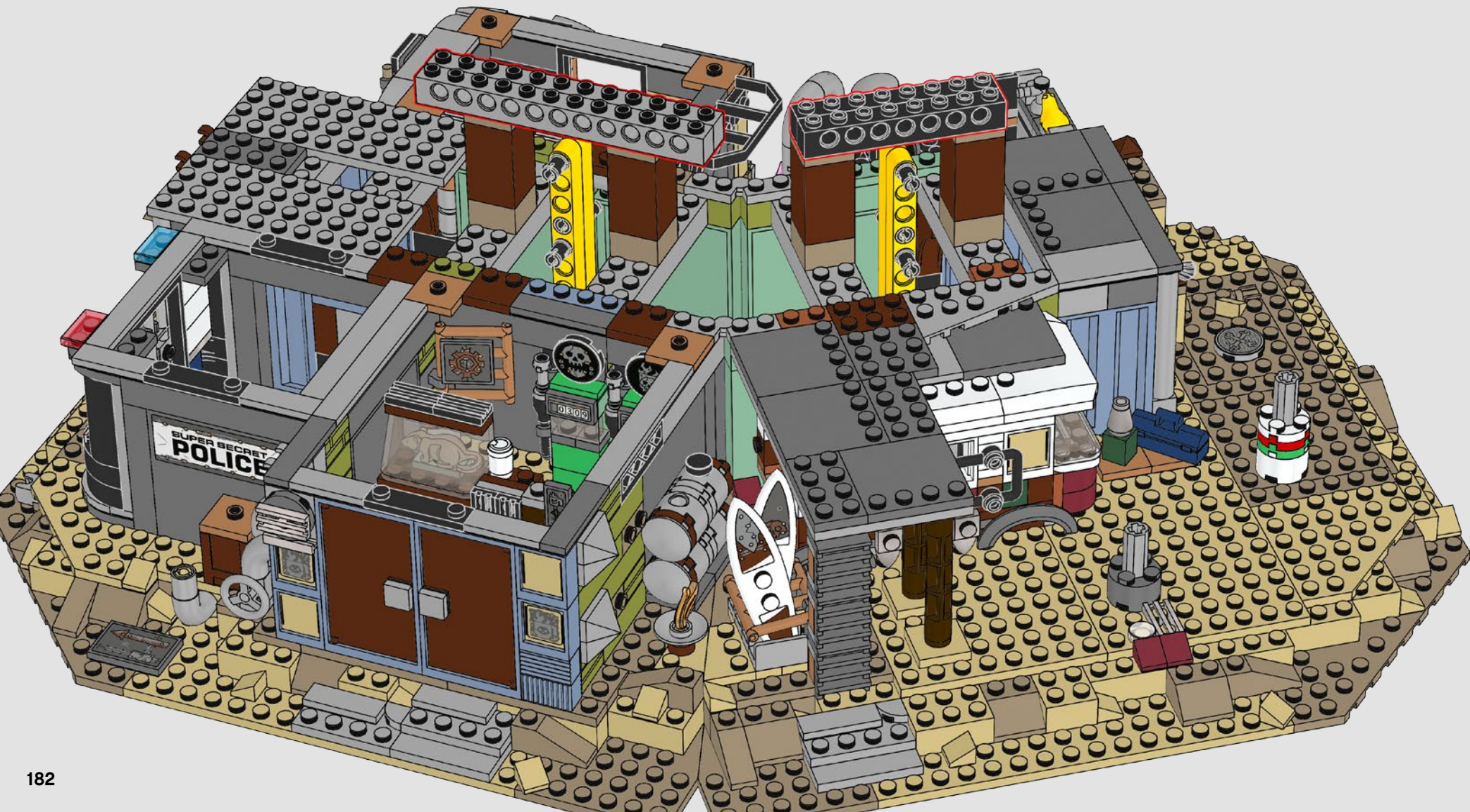

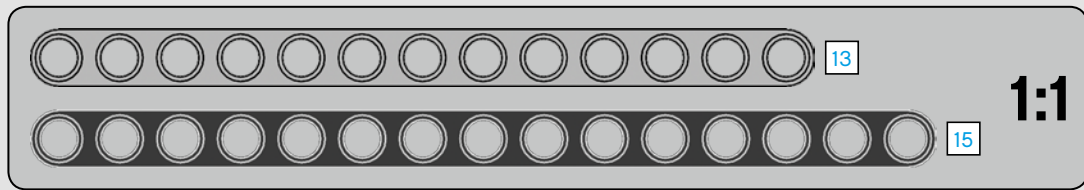
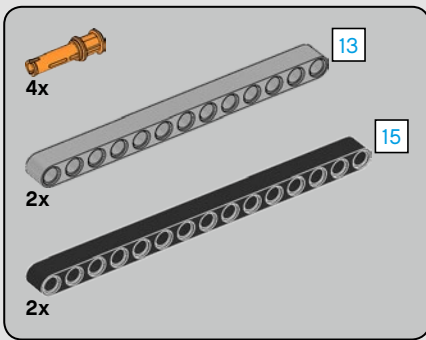

242

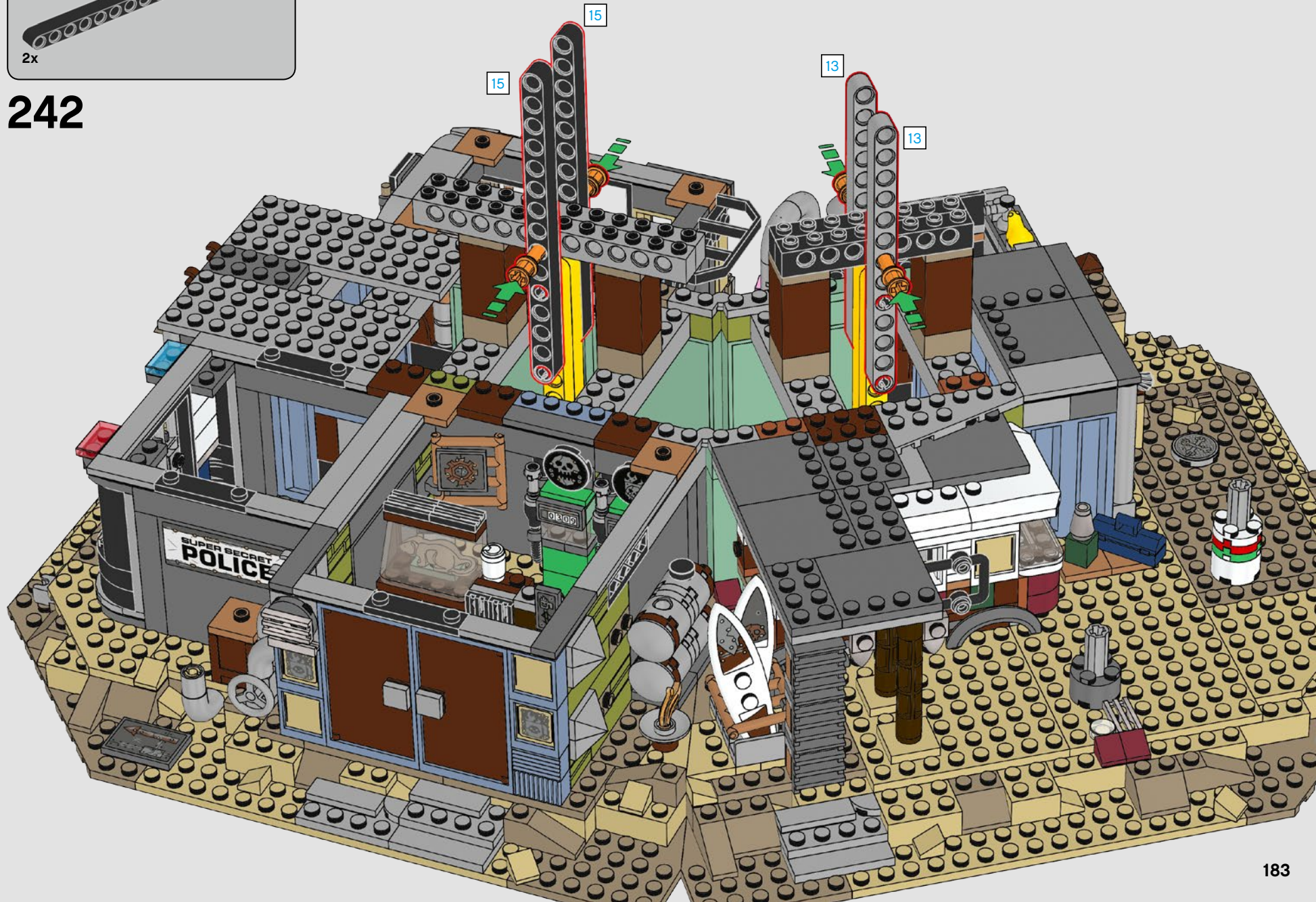

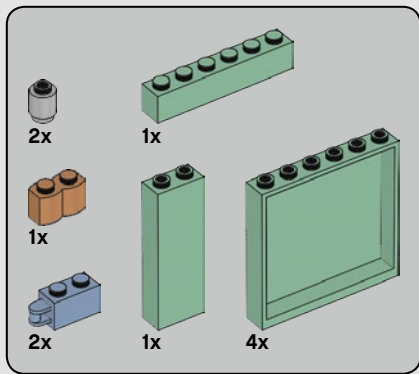

243

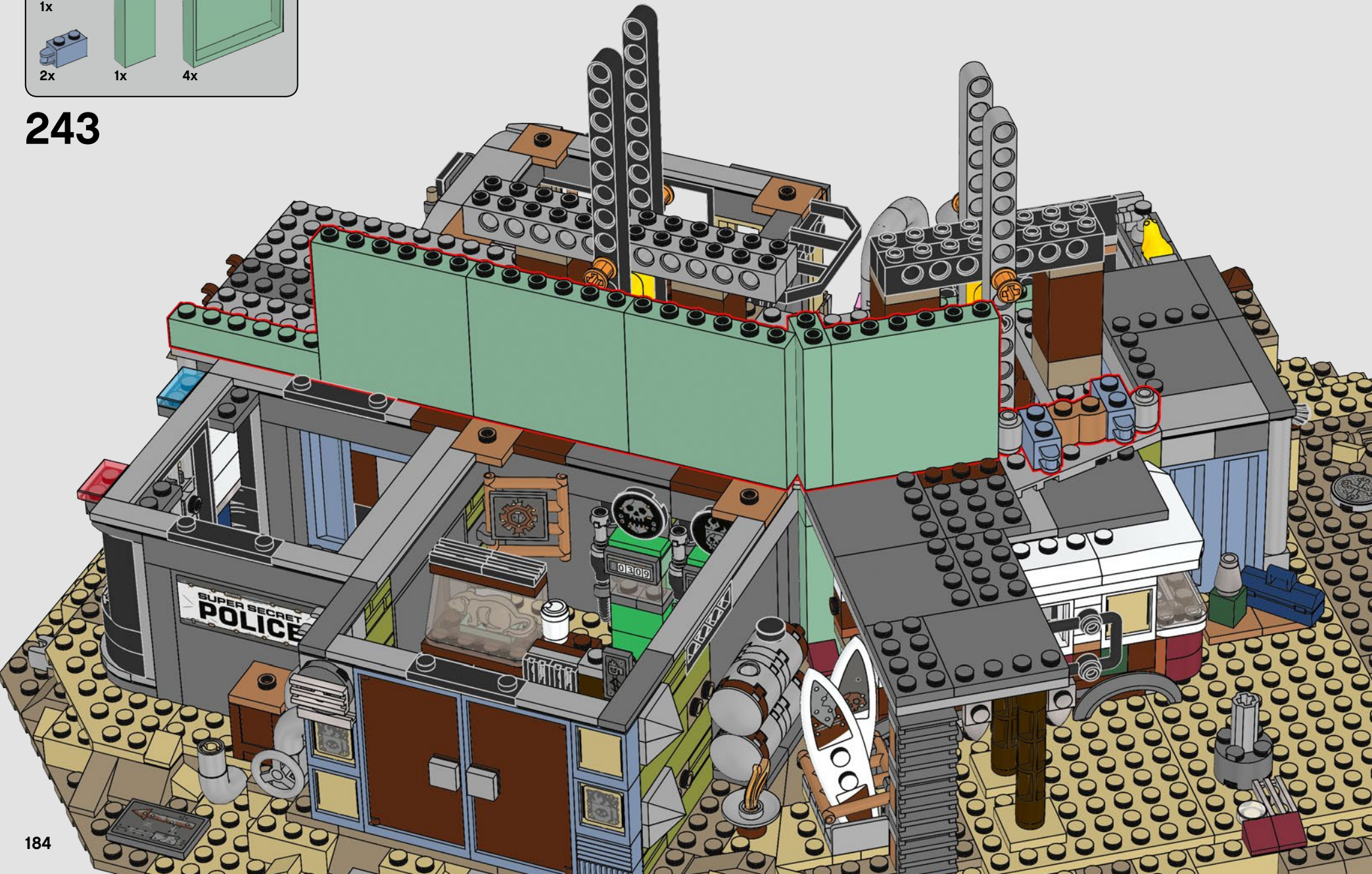



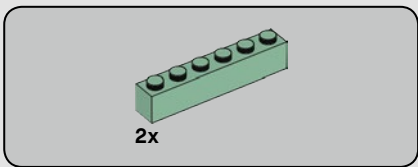

244

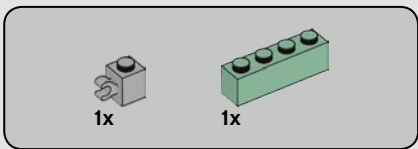
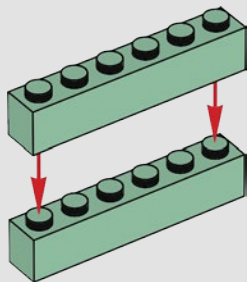

245

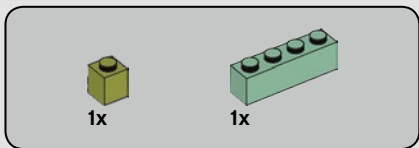
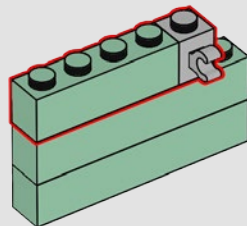

246

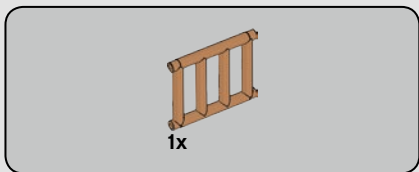
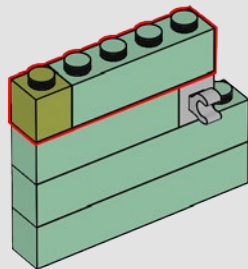

247

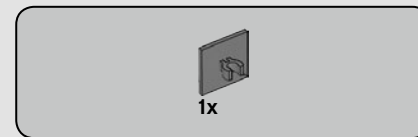
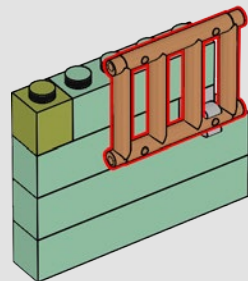

248

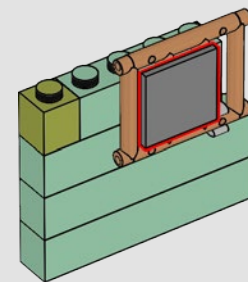

249

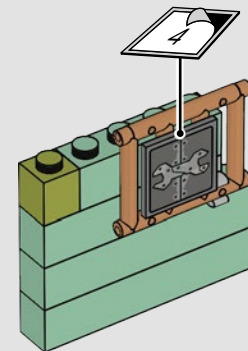

250

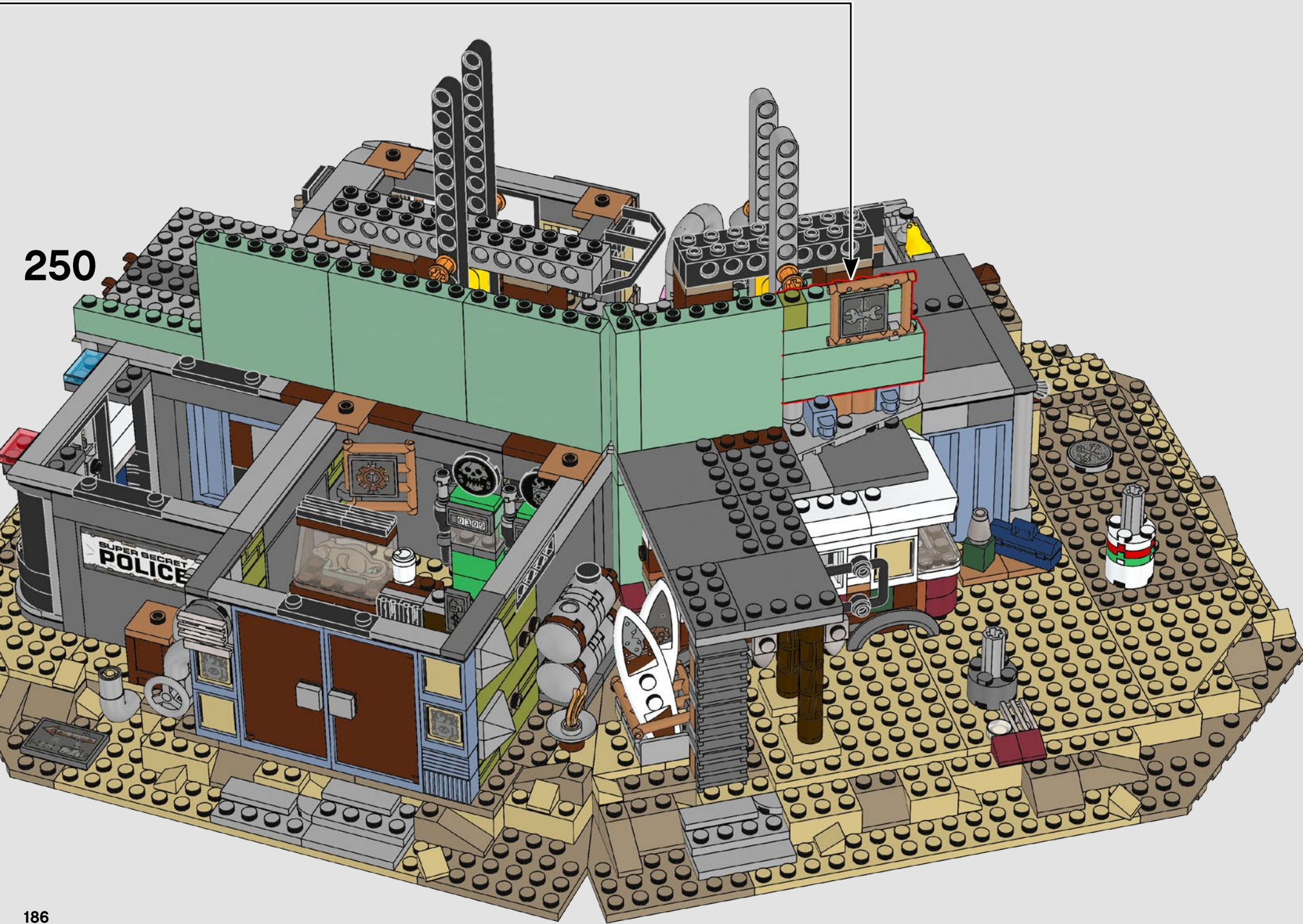

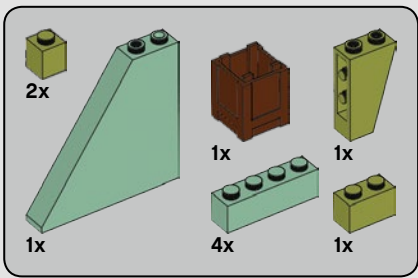

251

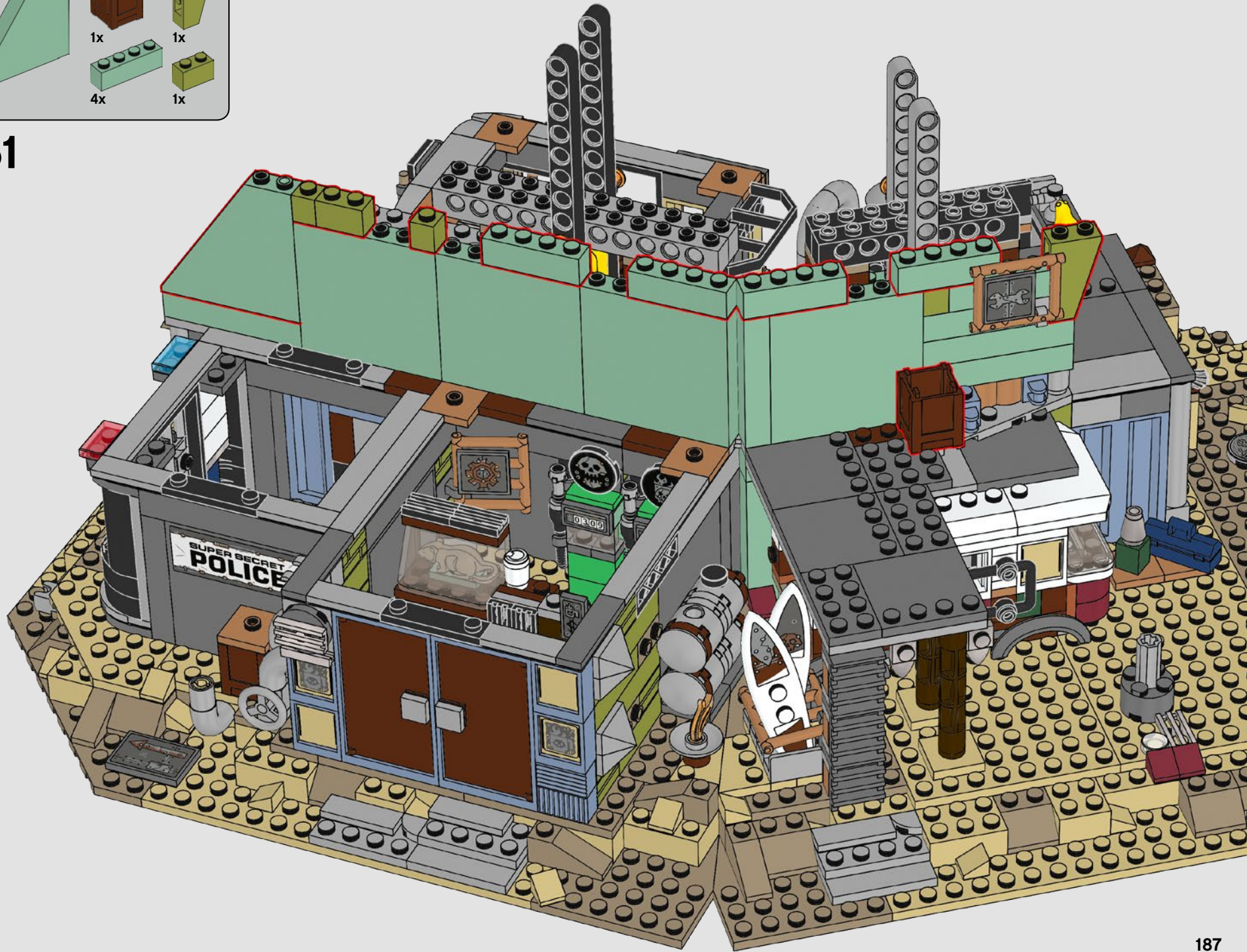

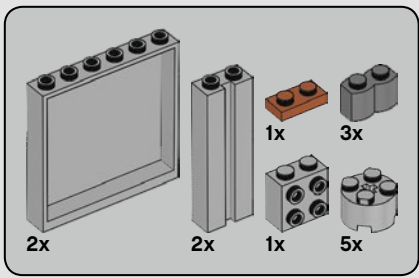

252

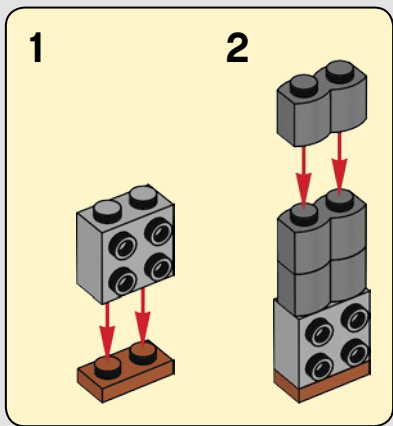
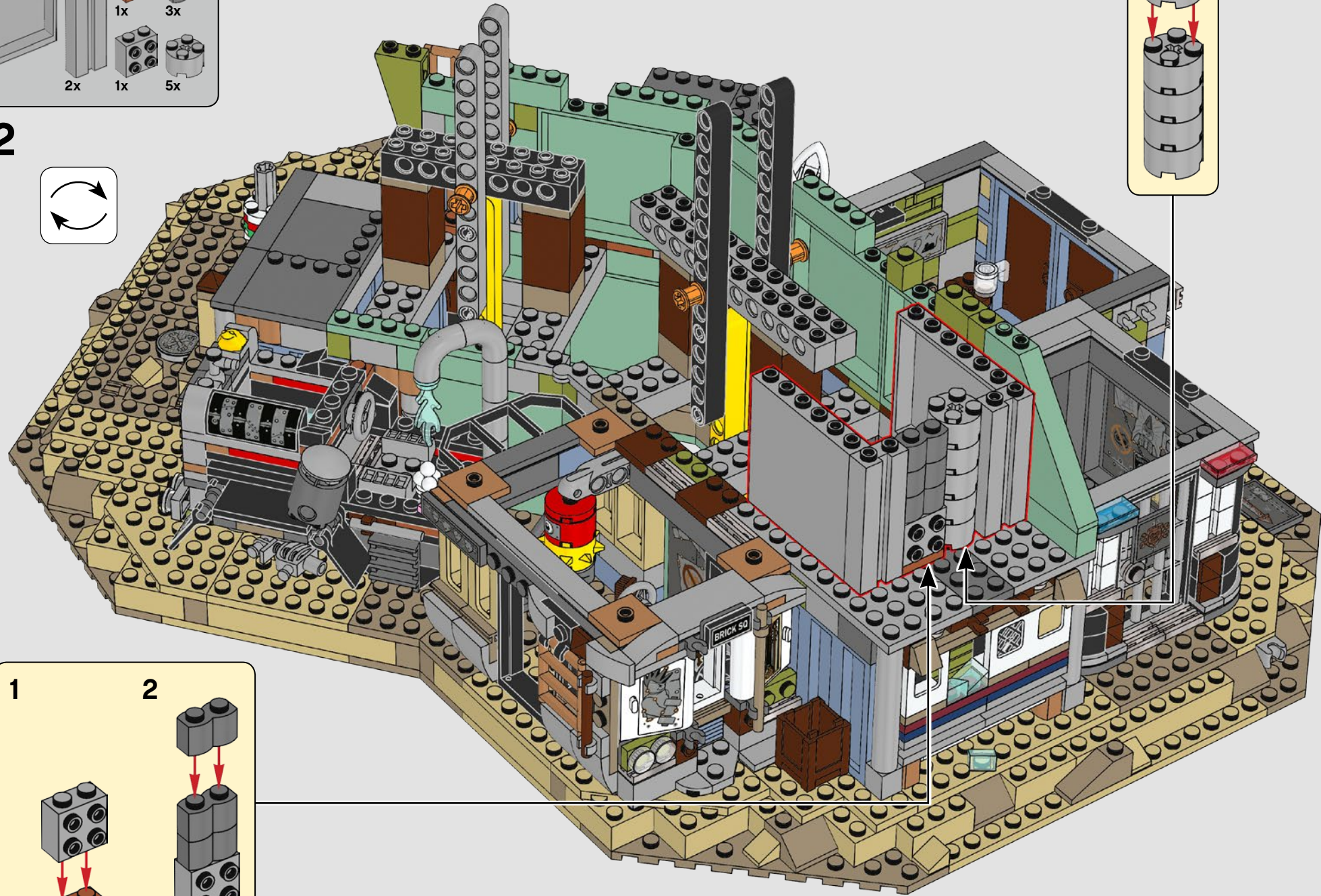
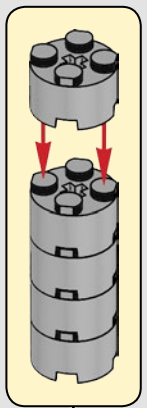
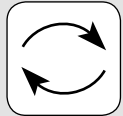

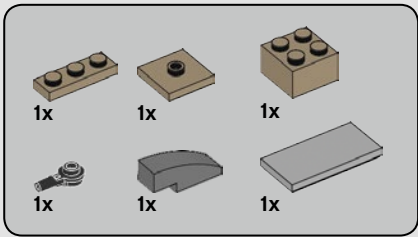

253

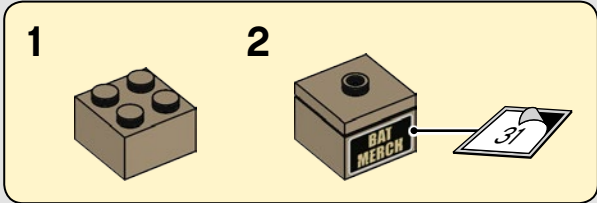
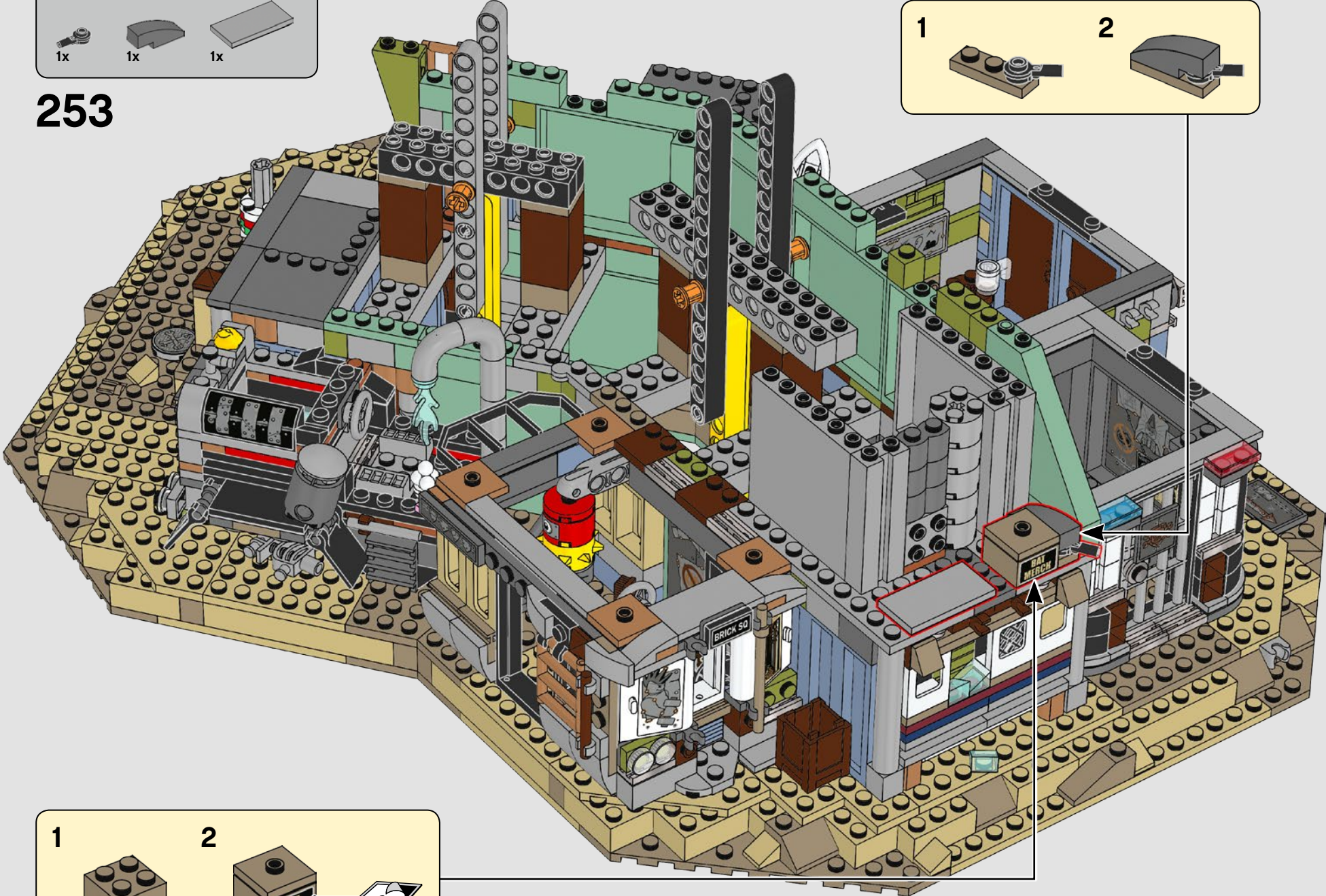
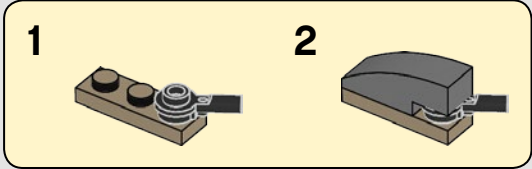

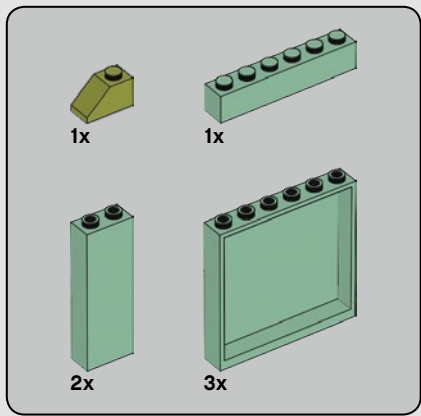

254

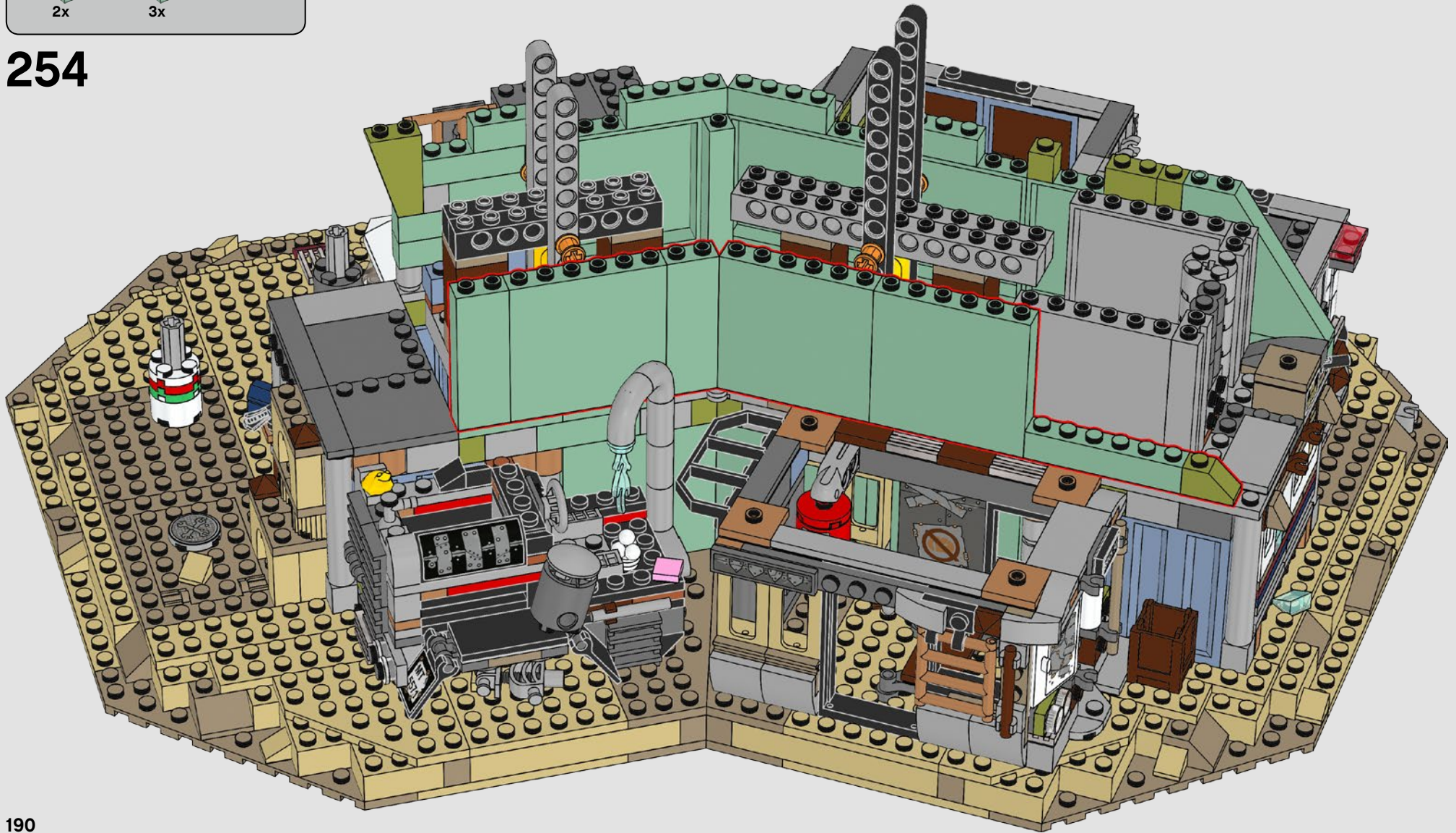

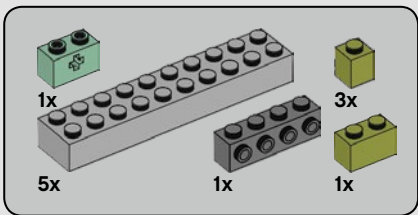

255

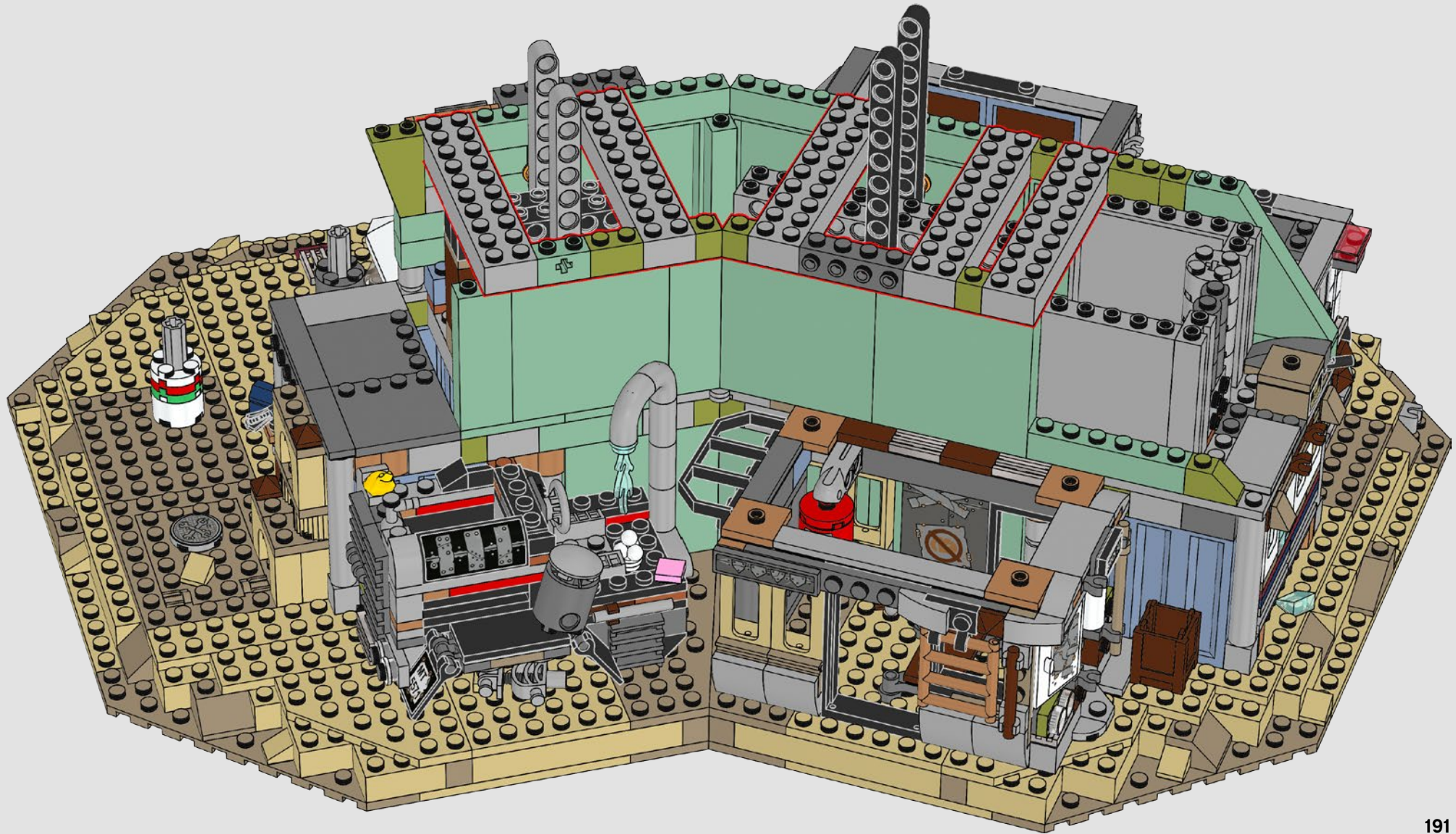

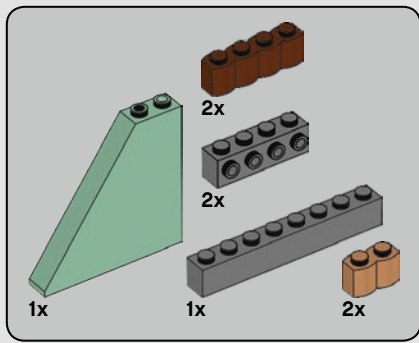

256

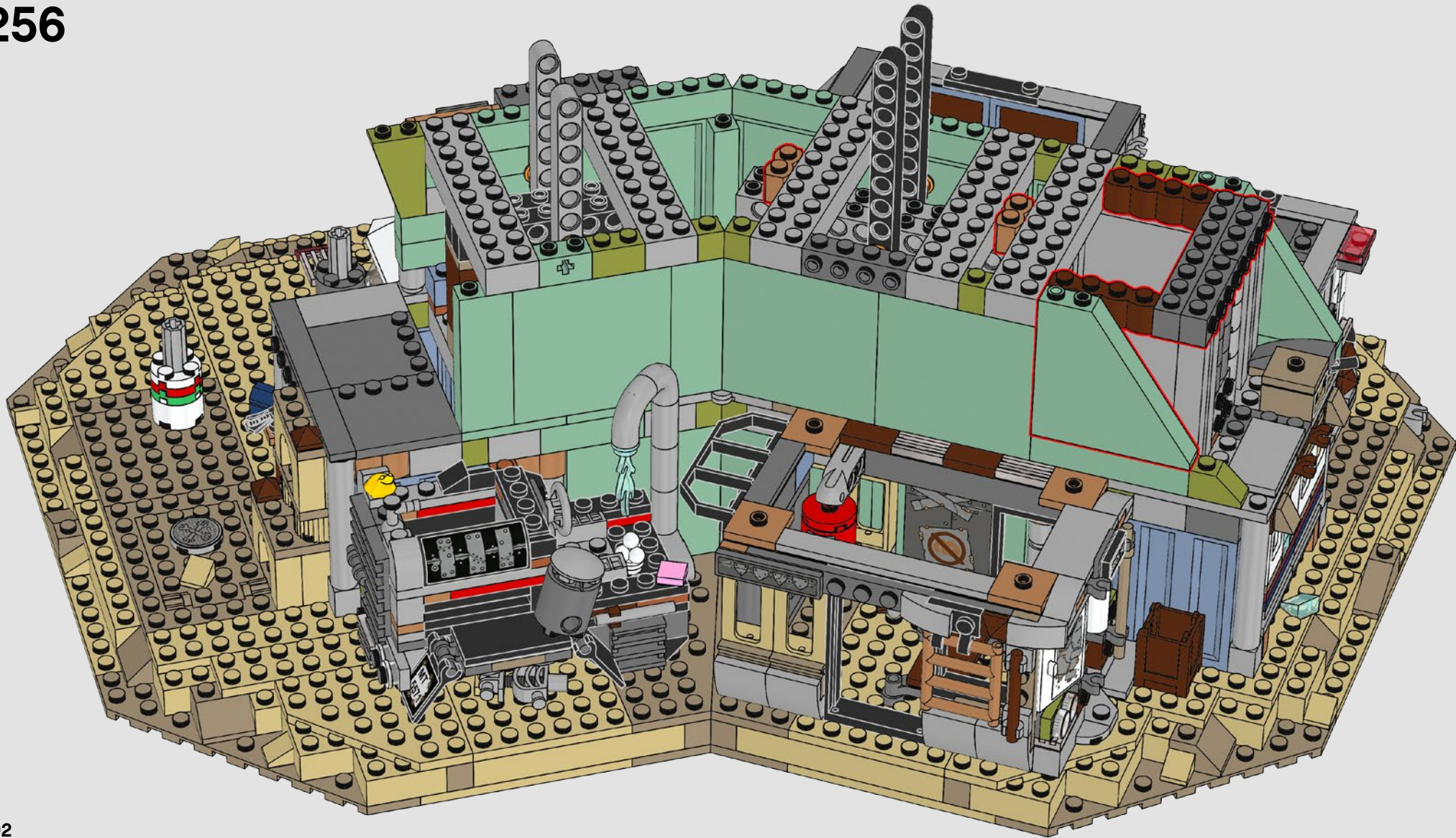



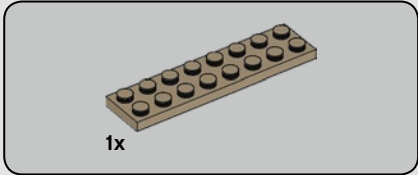
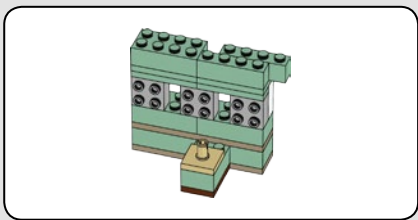

257

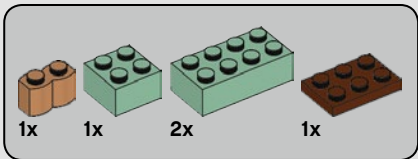
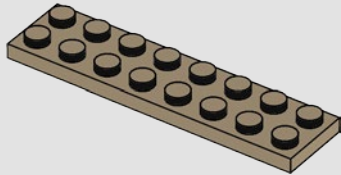

258

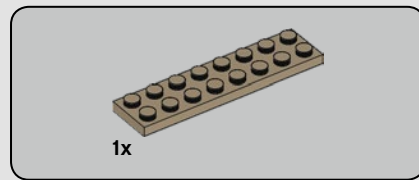
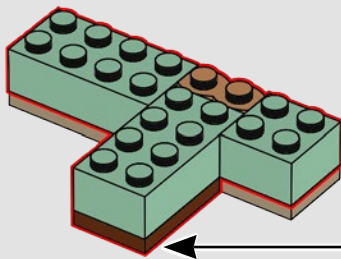
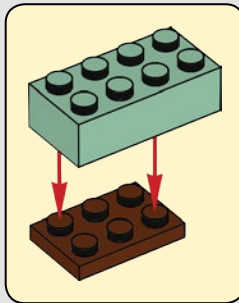

259

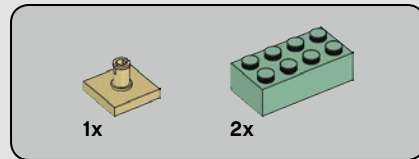
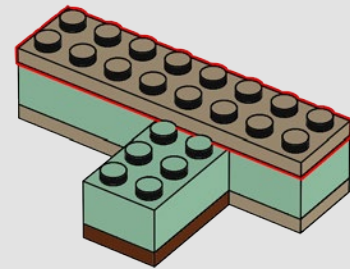

260

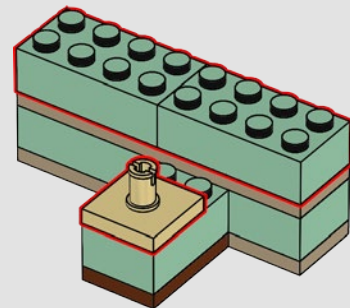



265

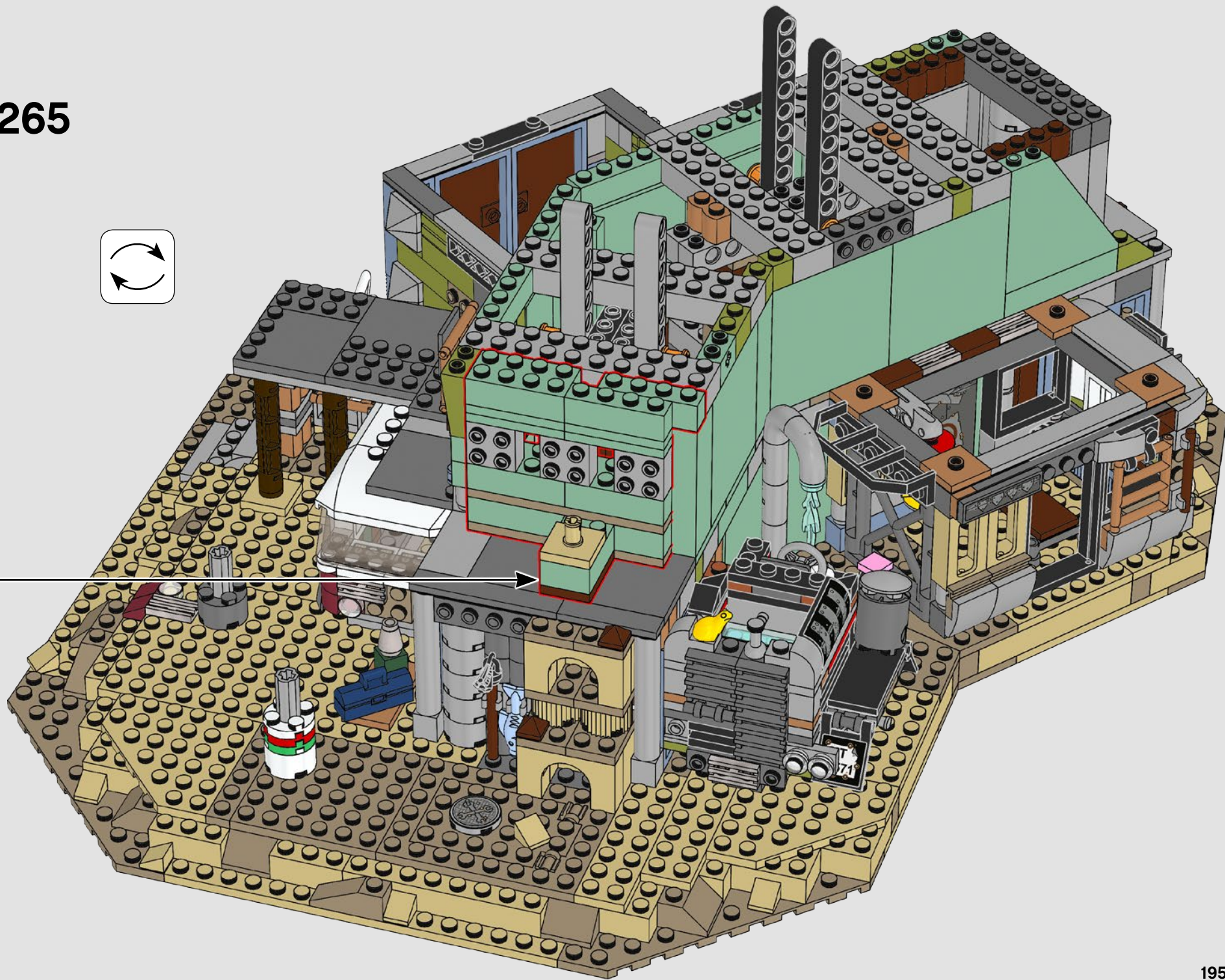
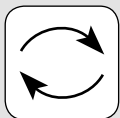

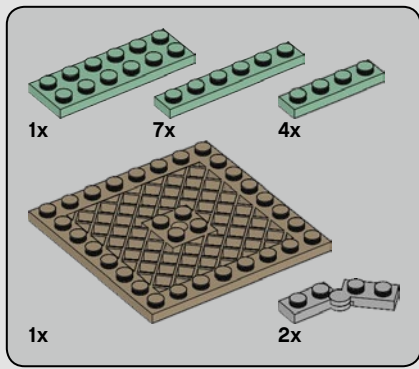

266

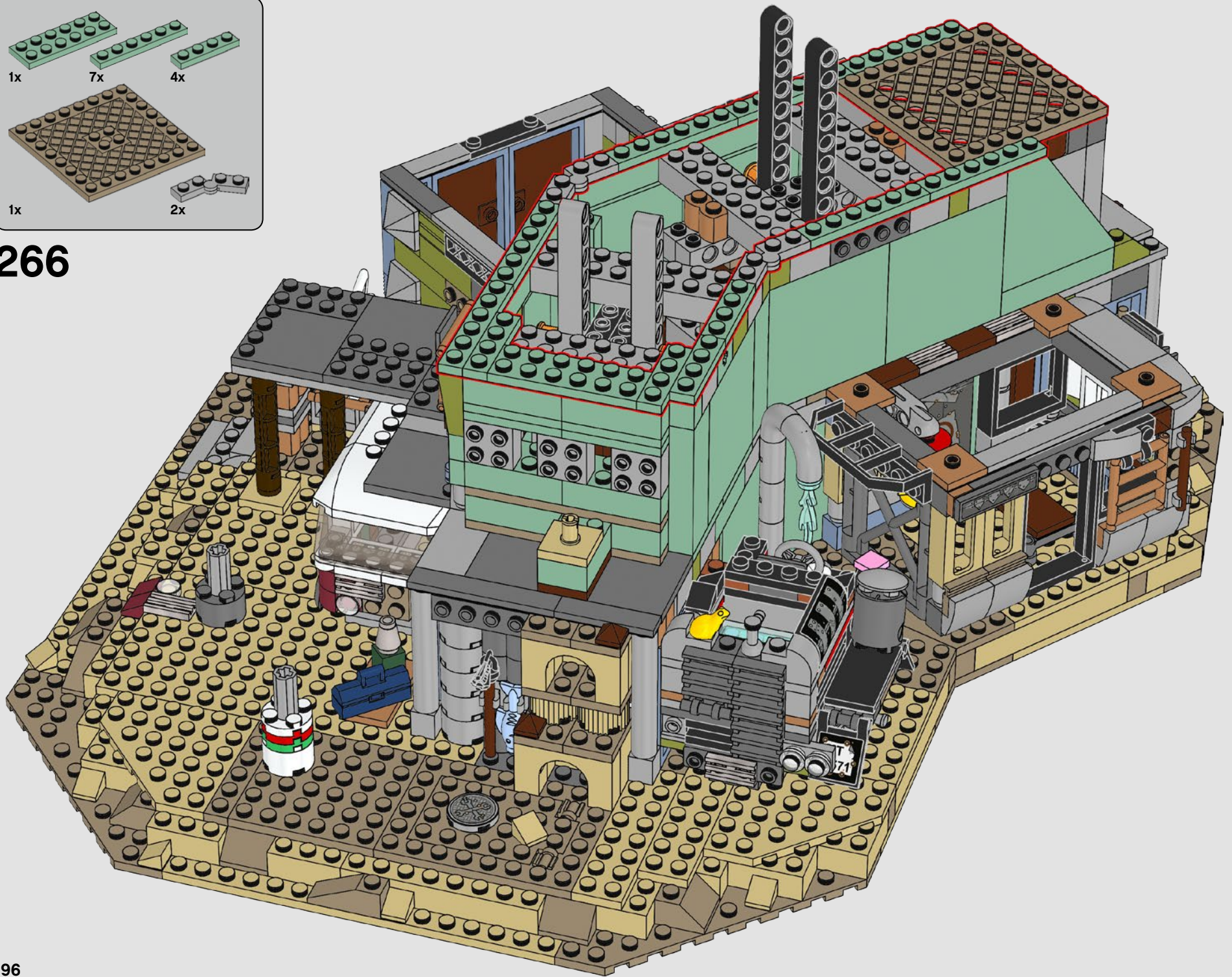

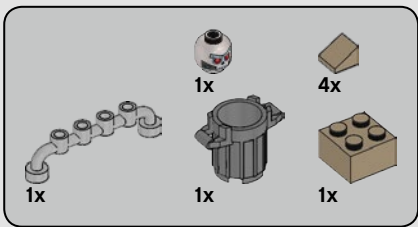

267

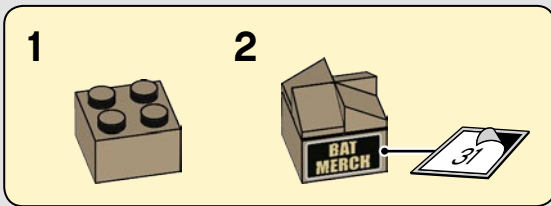
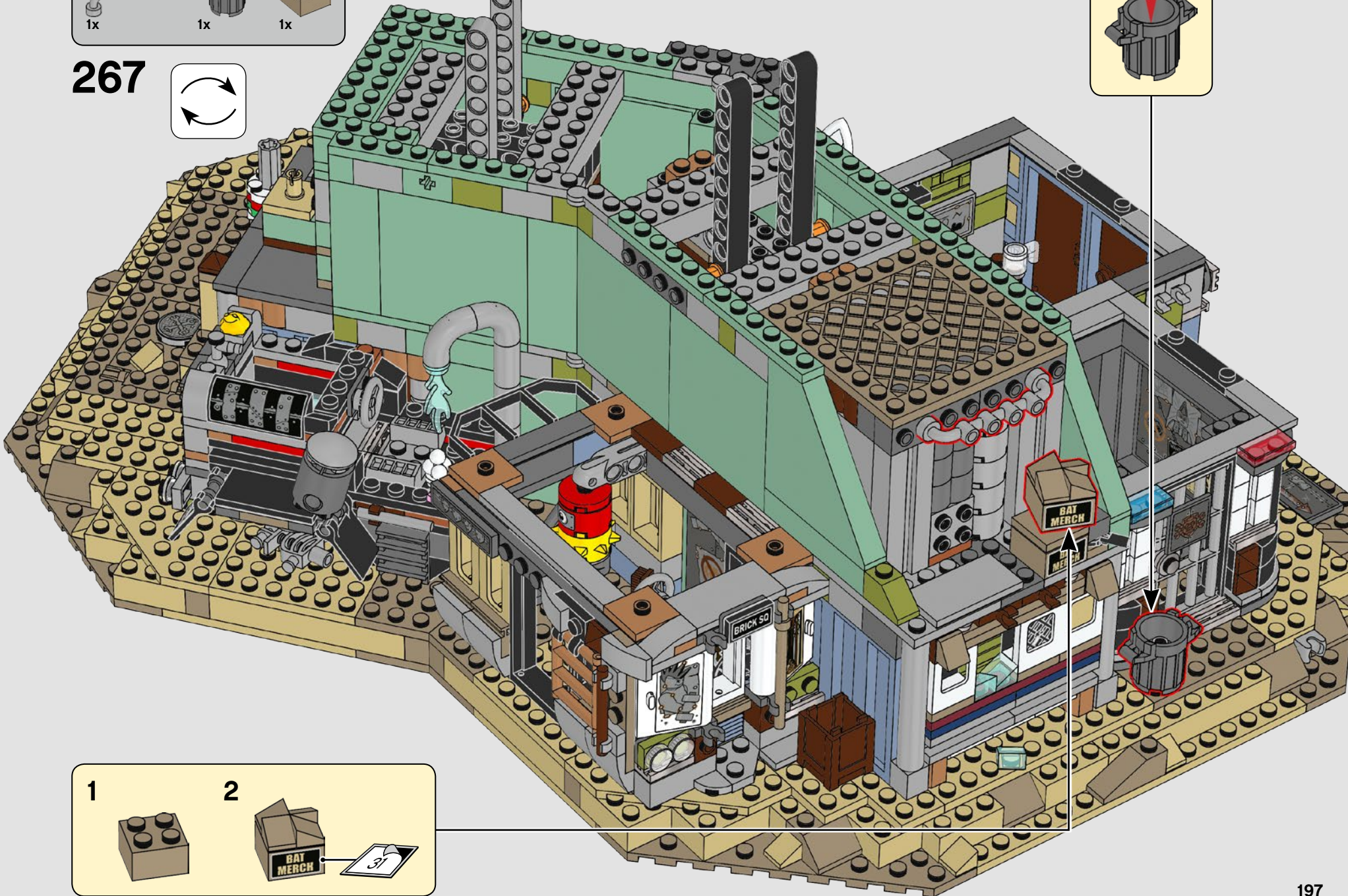
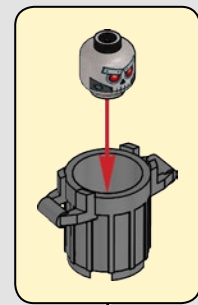
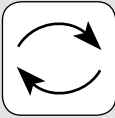

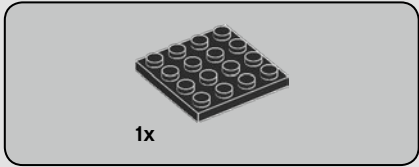
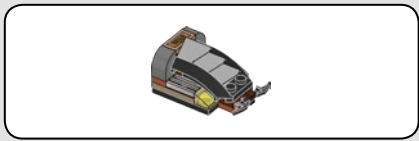

268

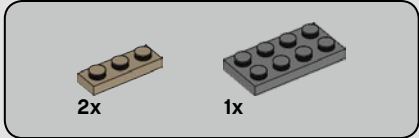
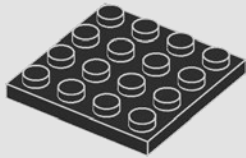

269

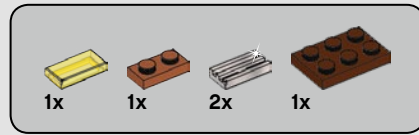
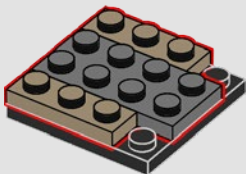

270

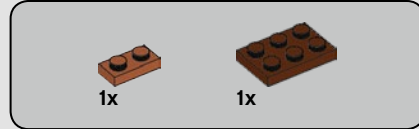
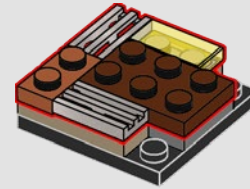

271

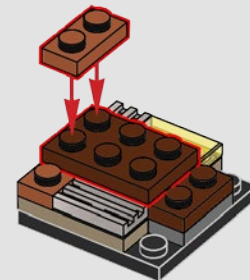

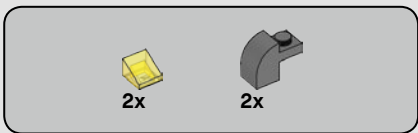

272

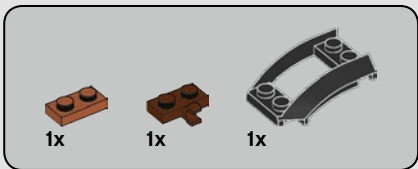
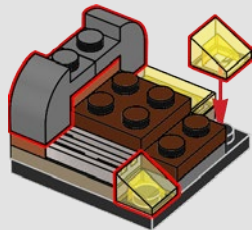

273

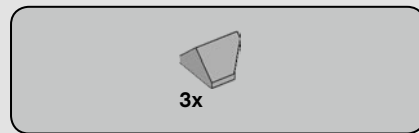
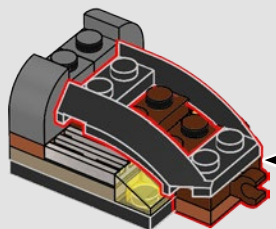
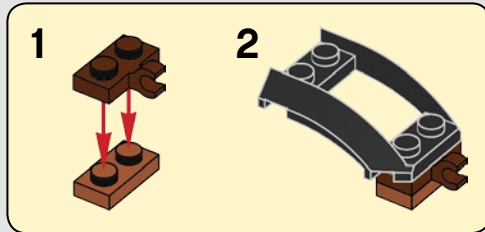

274

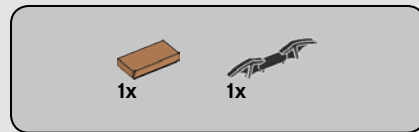
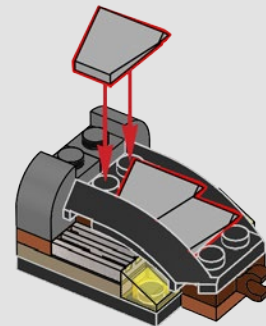

275

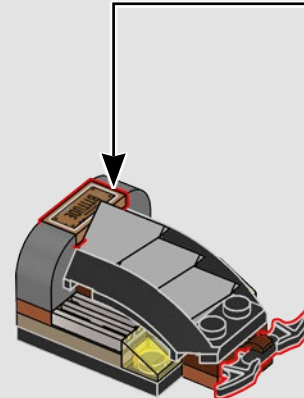
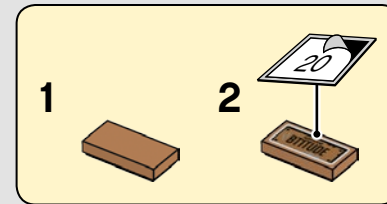

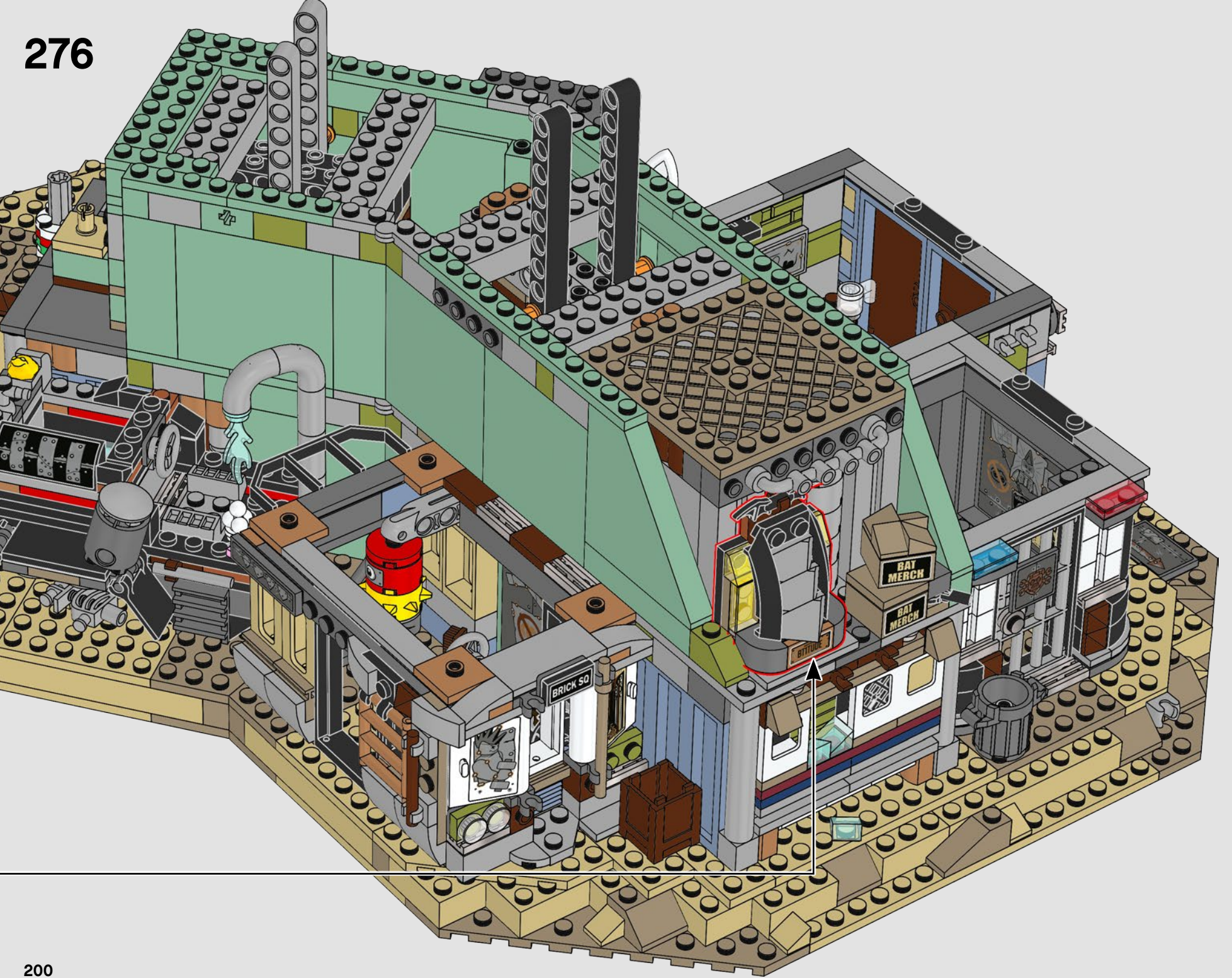



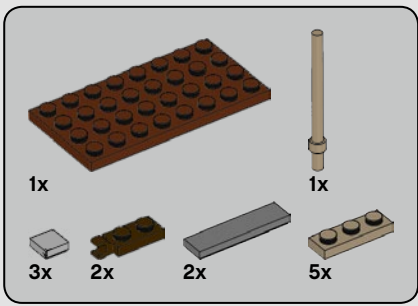

277

1

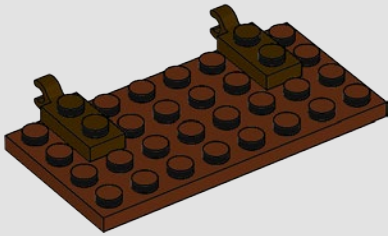

2

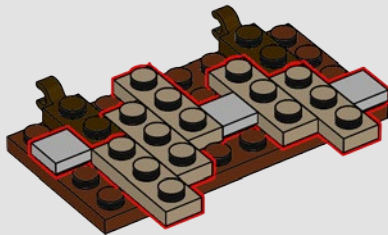

3

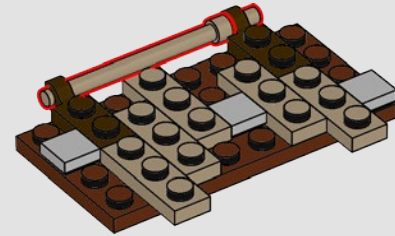

4

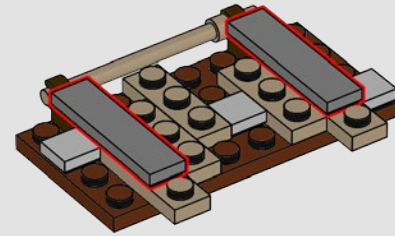

5

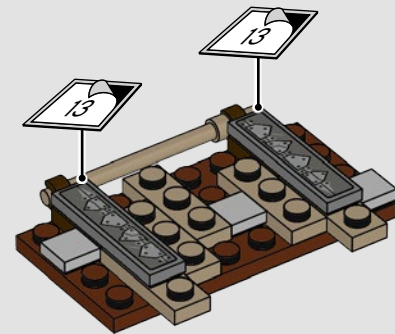

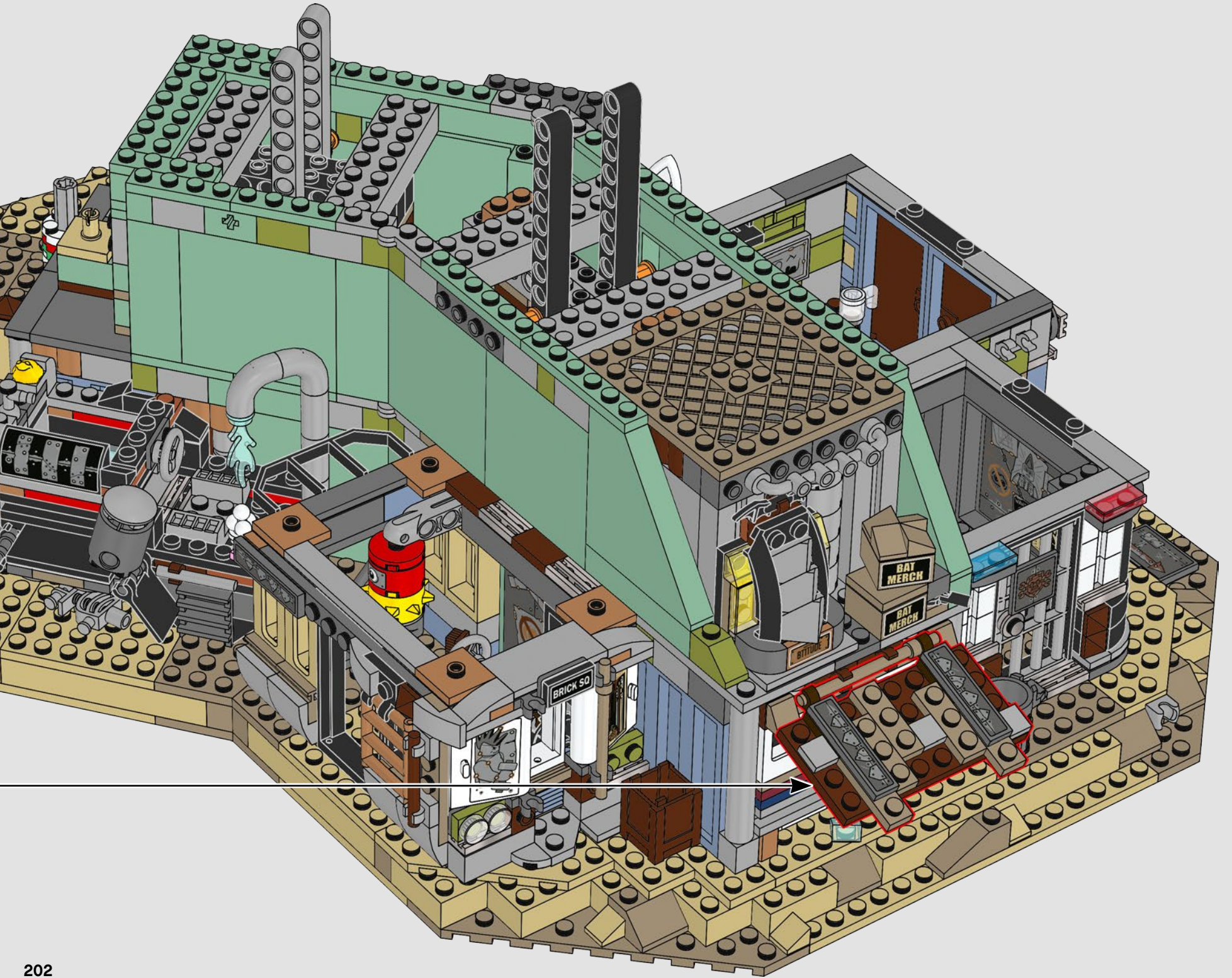

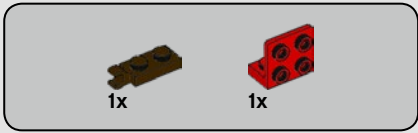

278

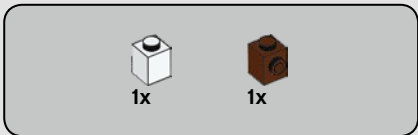
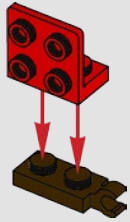

279

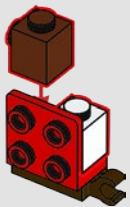

280

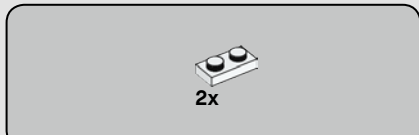

281

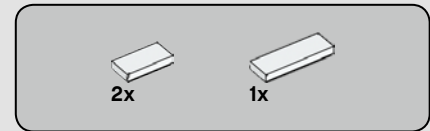
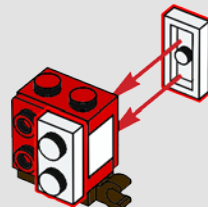

282

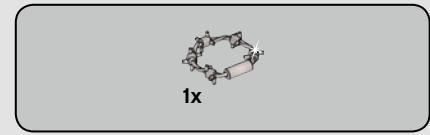

283

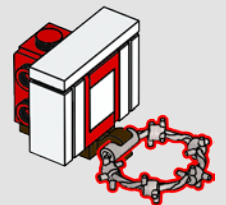

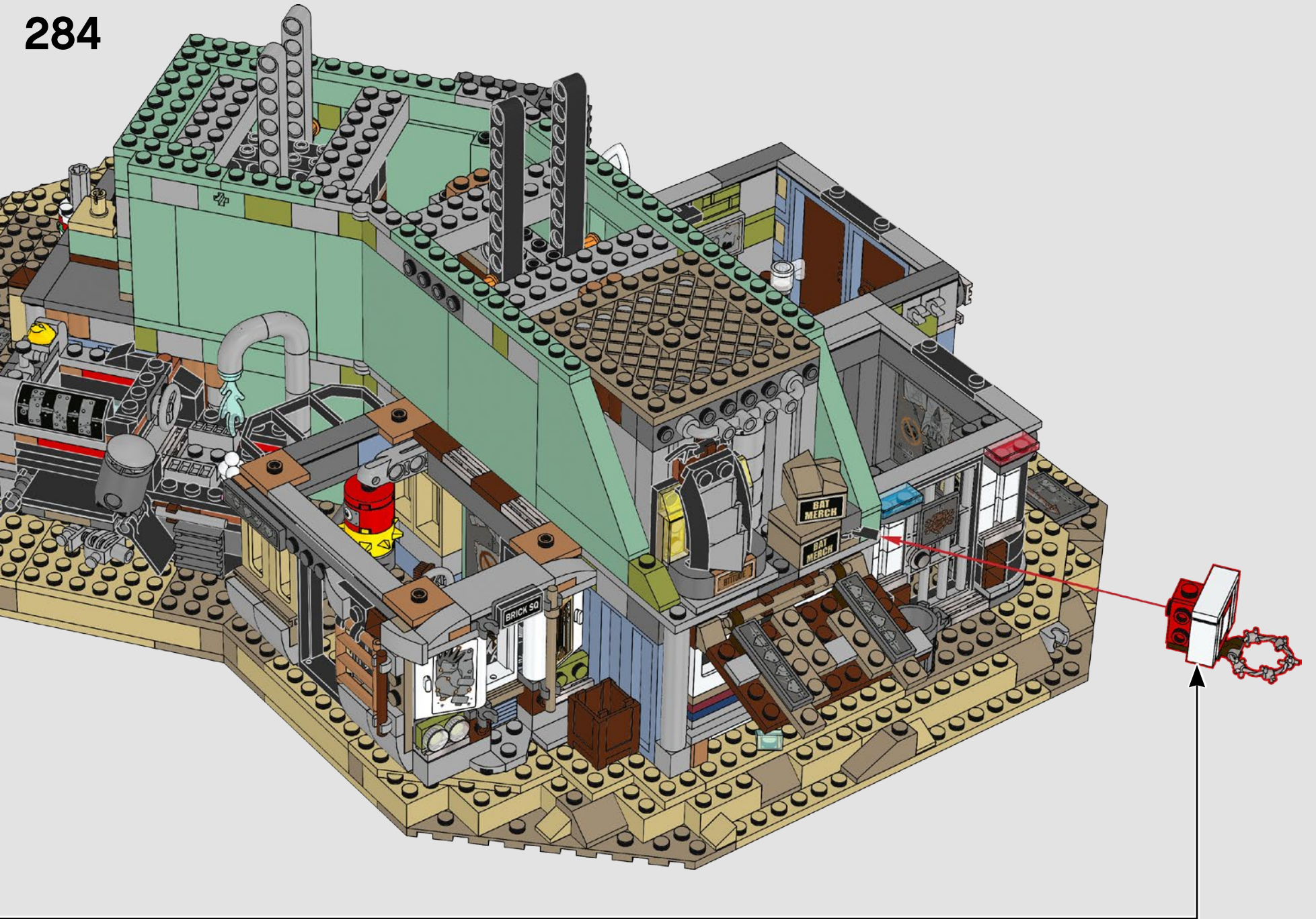

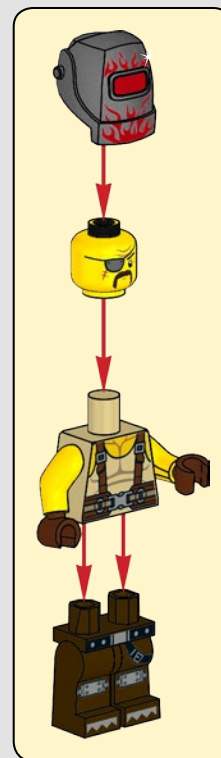
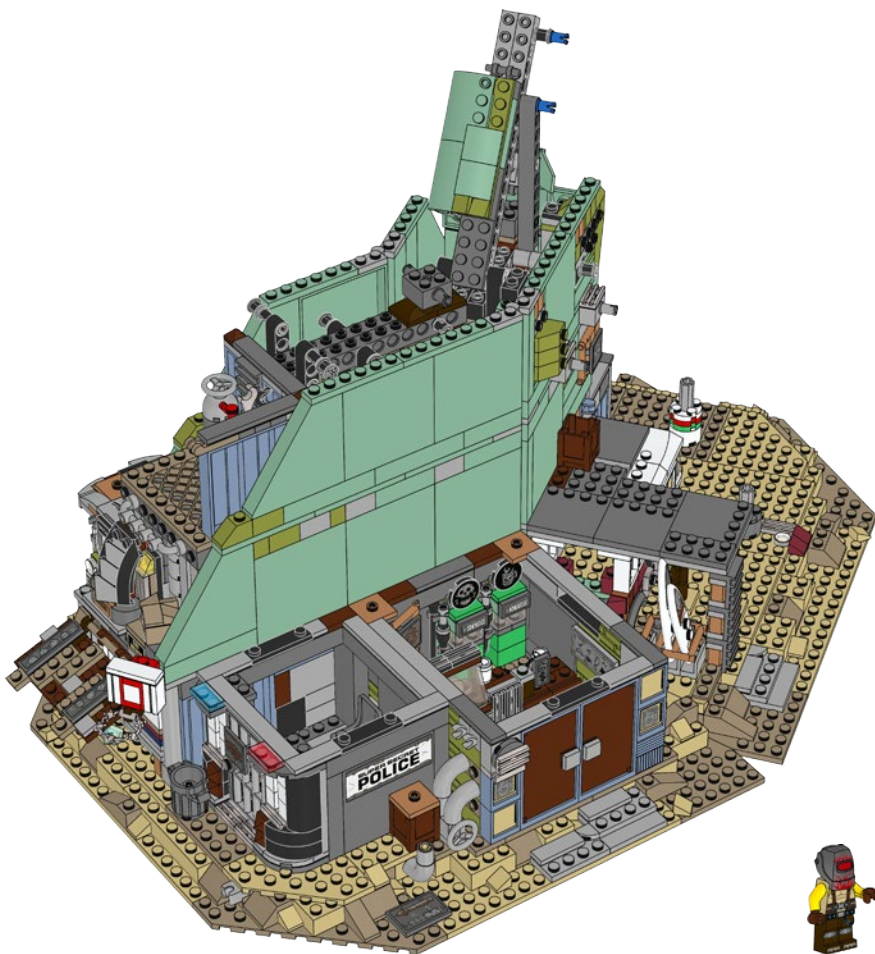
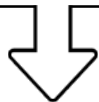

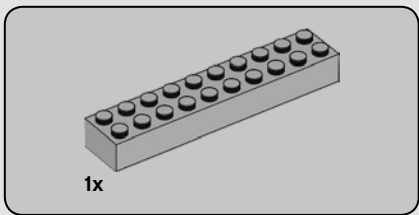

285

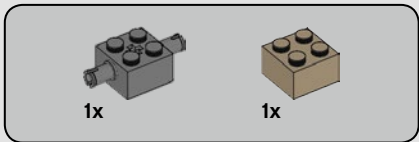
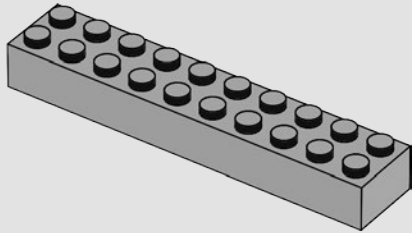

286

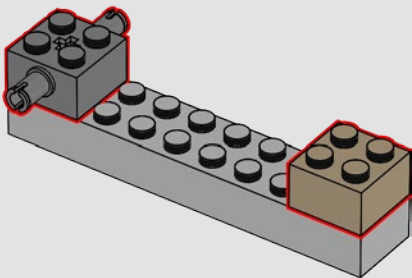

287

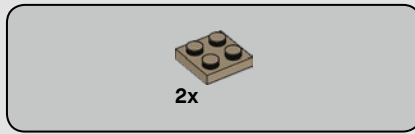
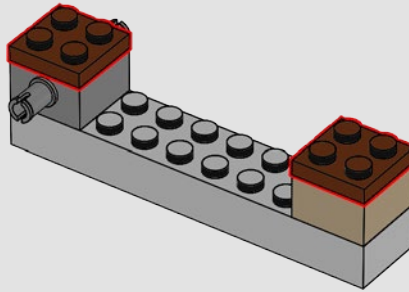

288

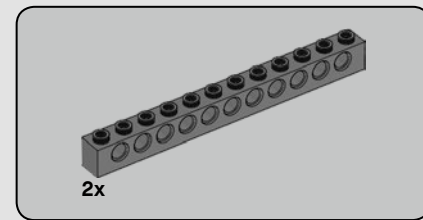
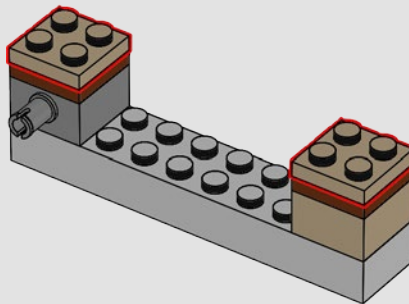

289

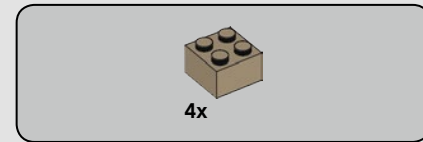
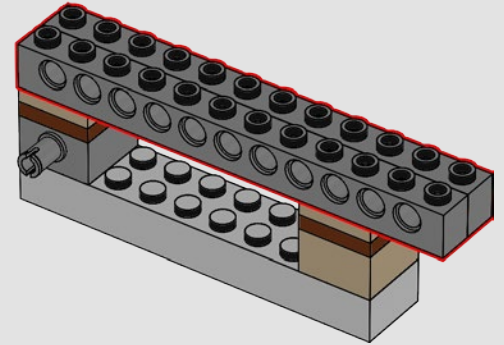

290

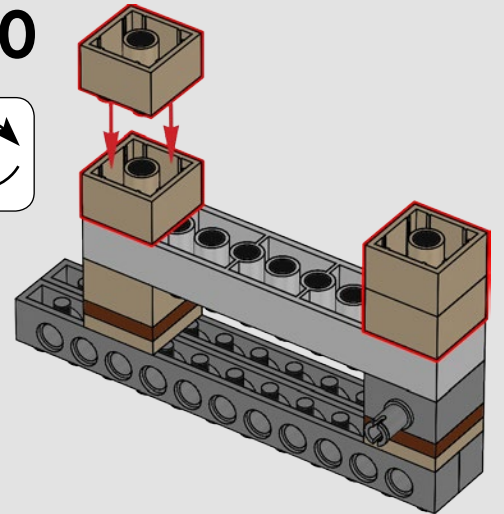
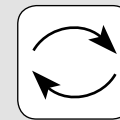



291

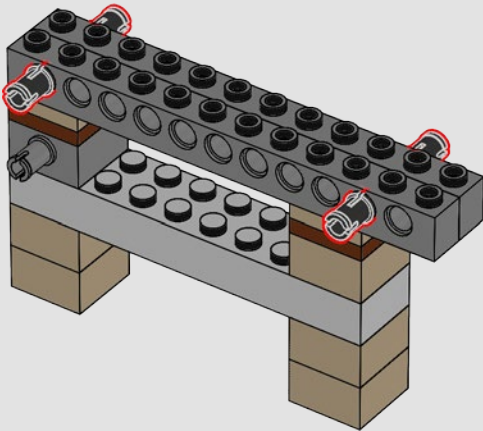
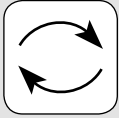

292

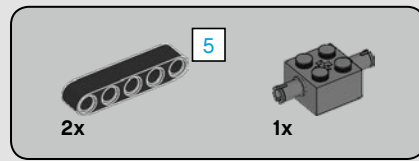
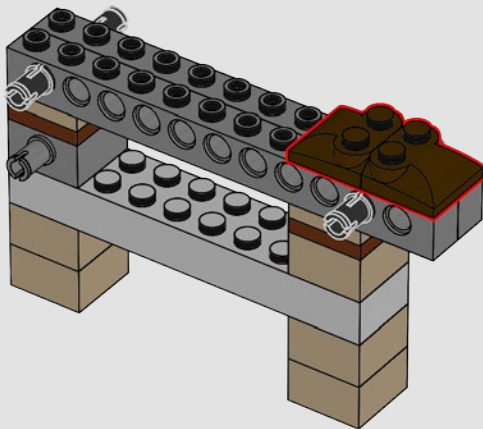

293

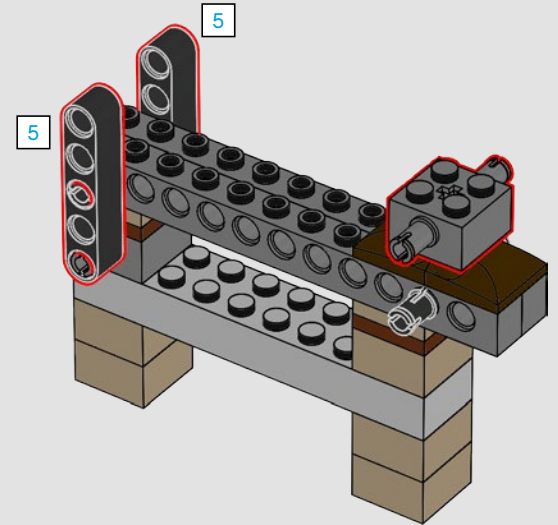

294

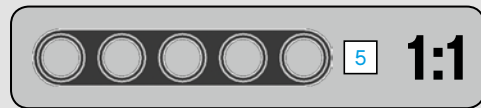
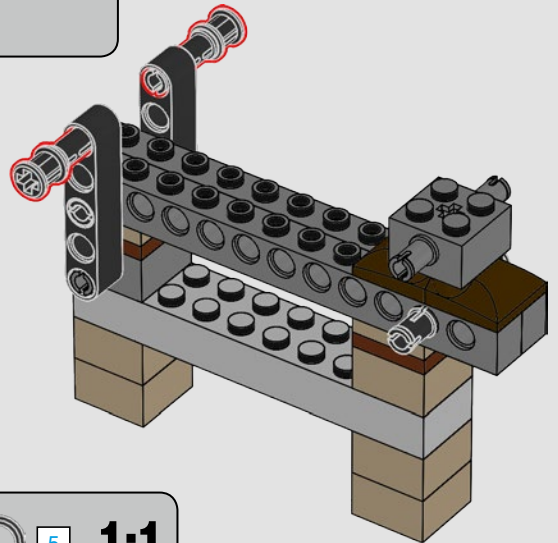

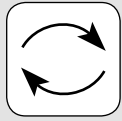

295

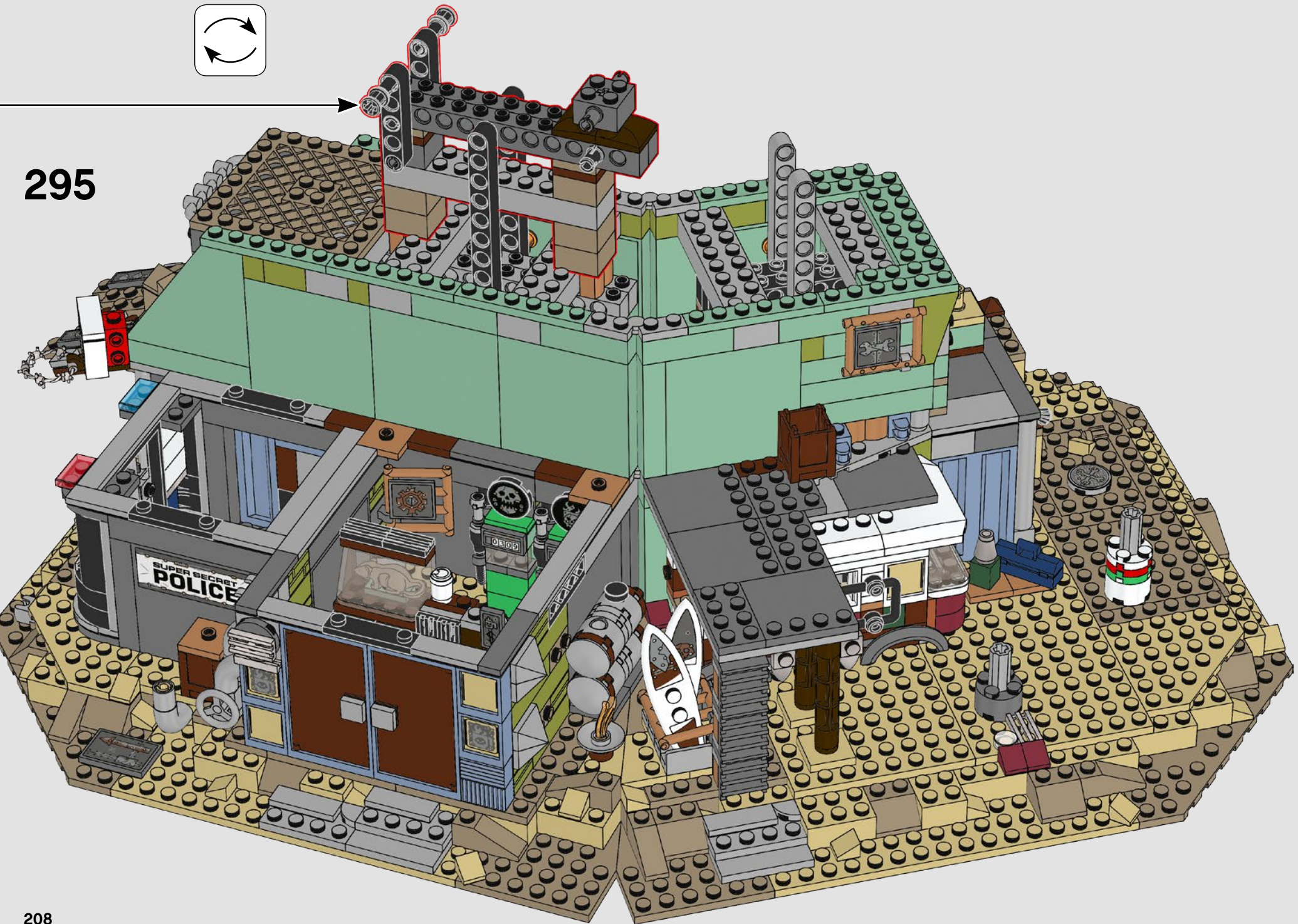



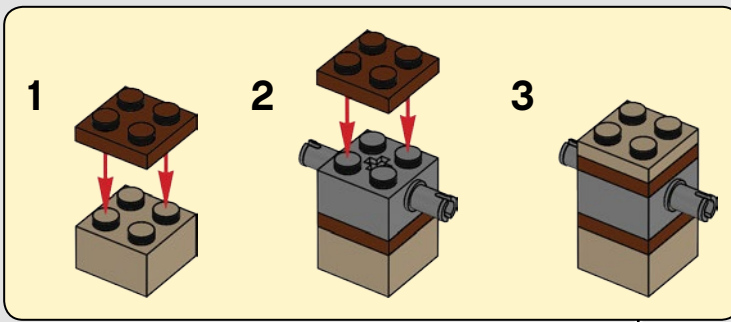
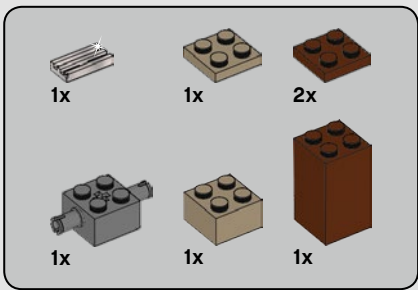

296

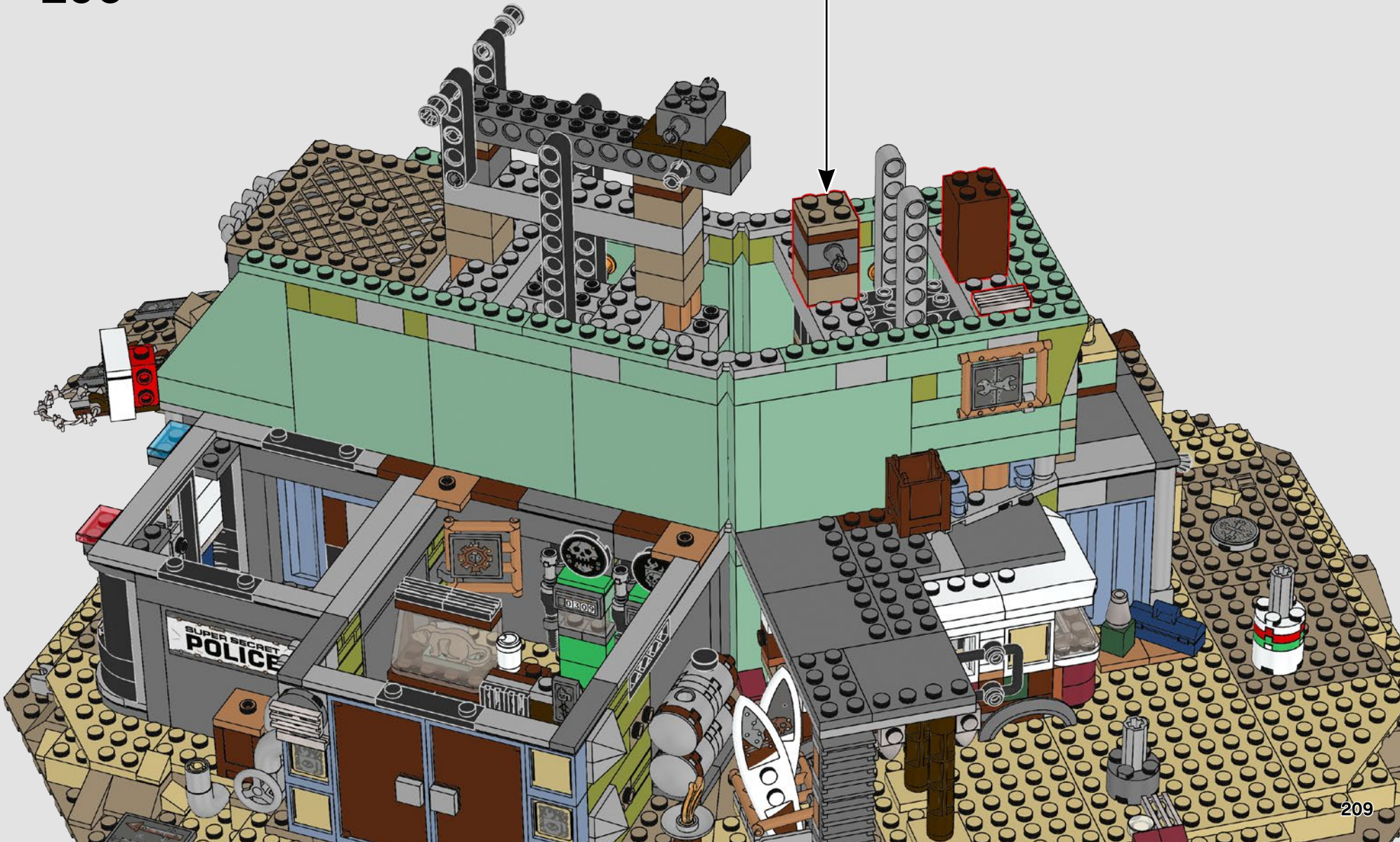

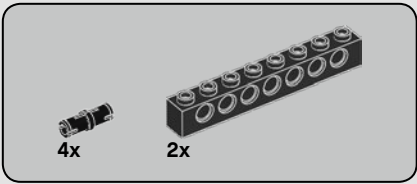

297

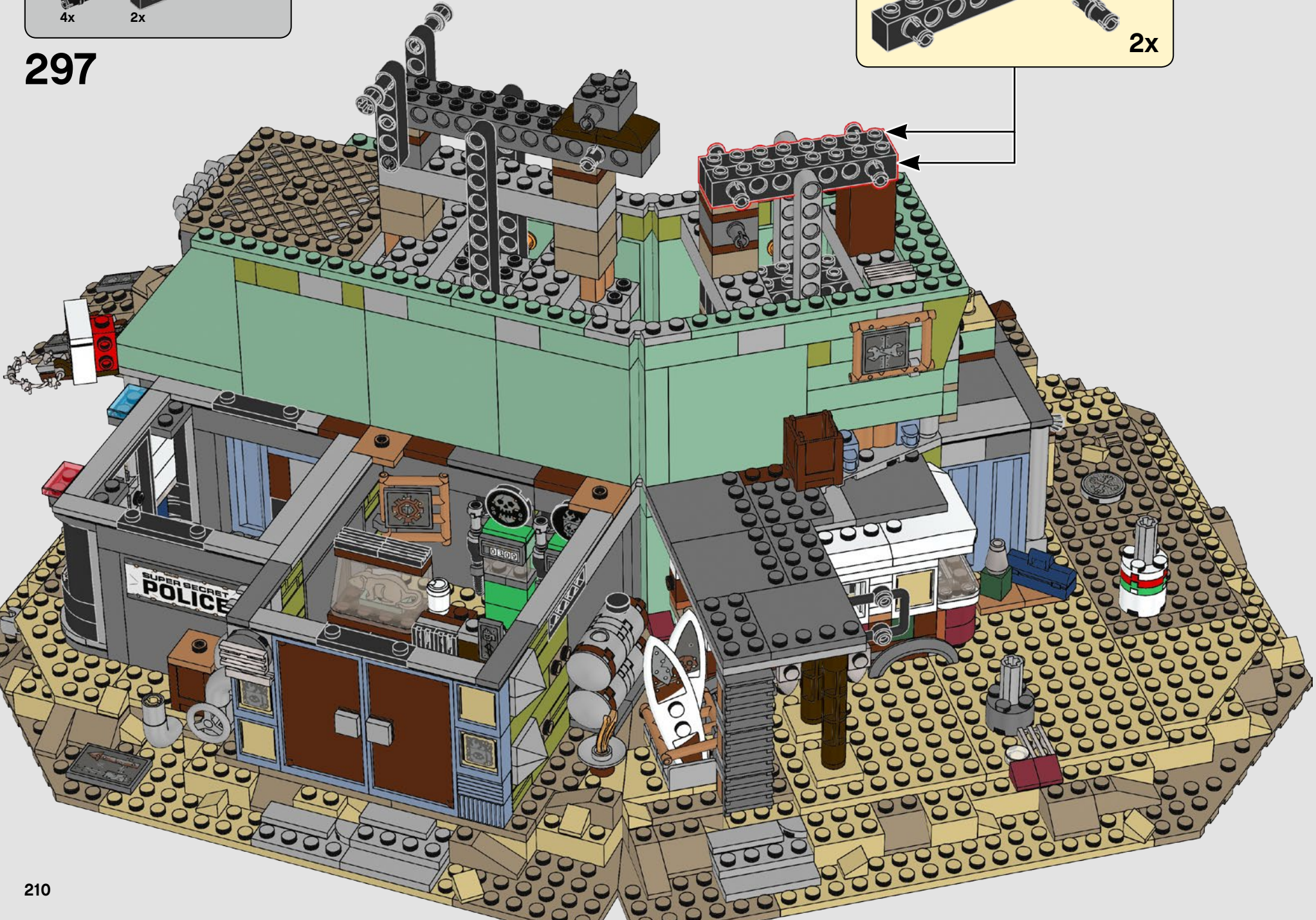
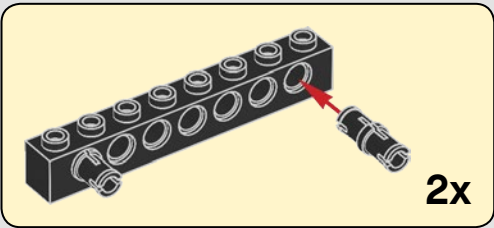

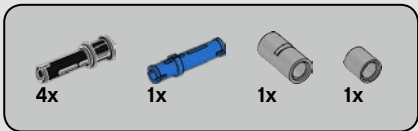

298

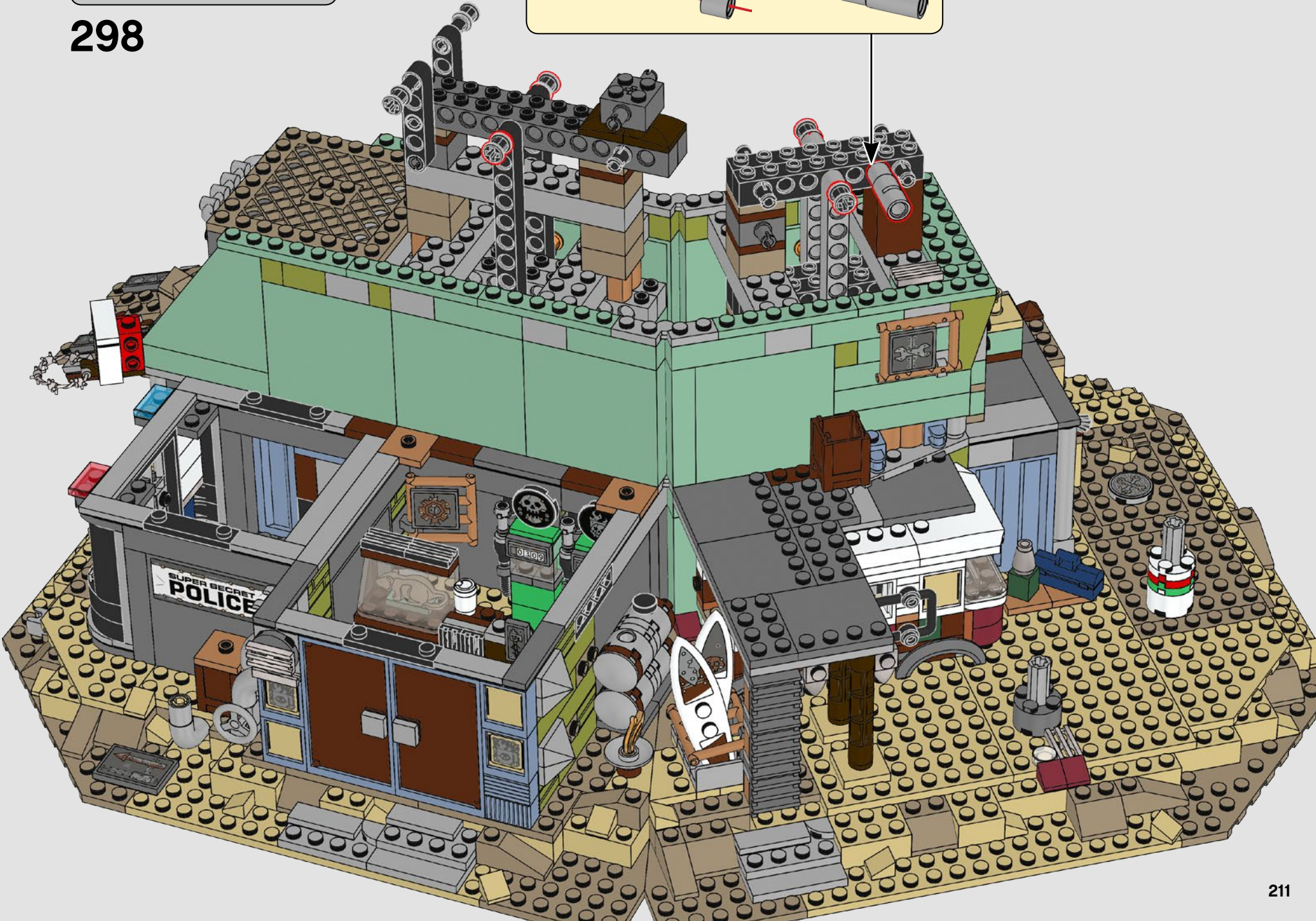
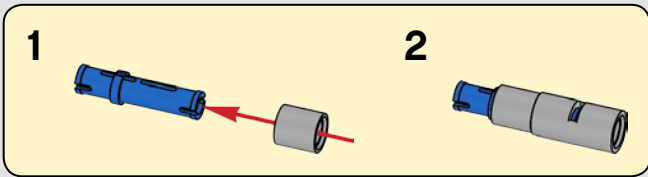

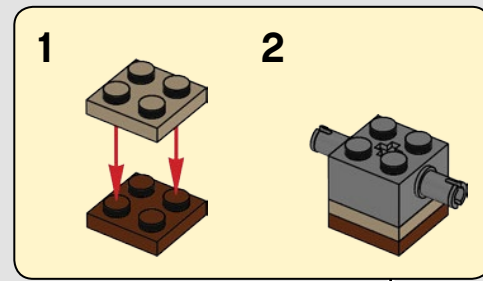
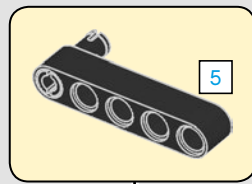
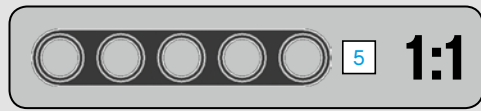
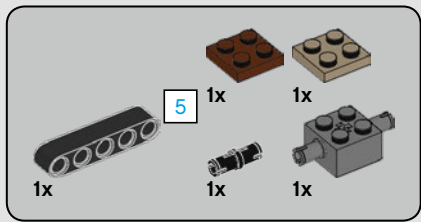

299

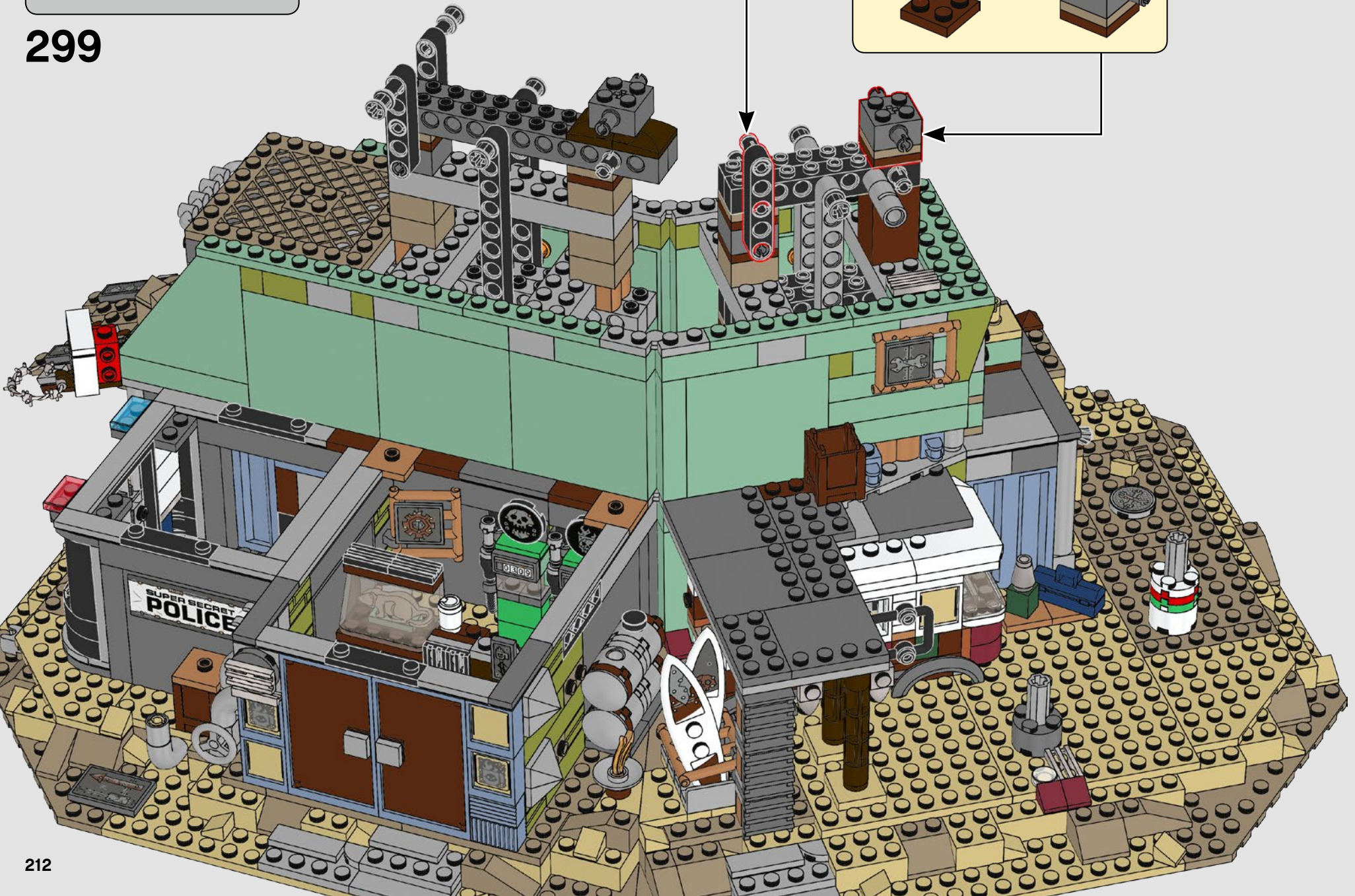

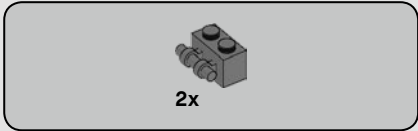
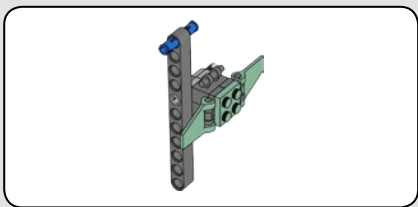

2x

**300**

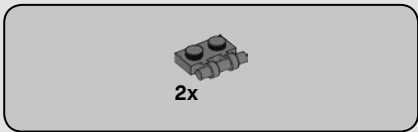
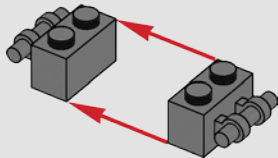

2x

**301**

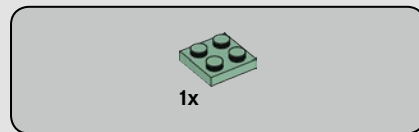
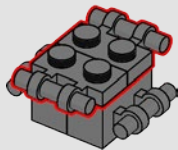

1x

**302**

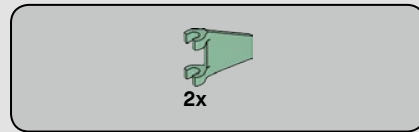
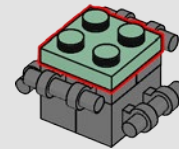

2x

**303**

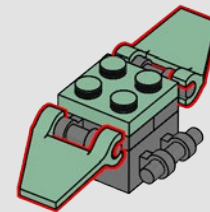



2x

# 304

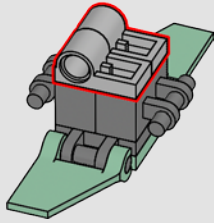
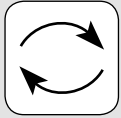

2x

# 305

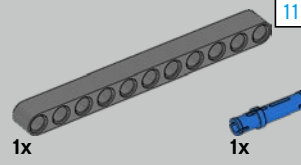
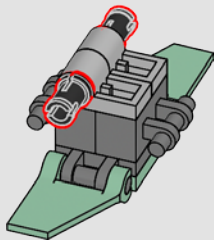

1x

1x

11

# 306

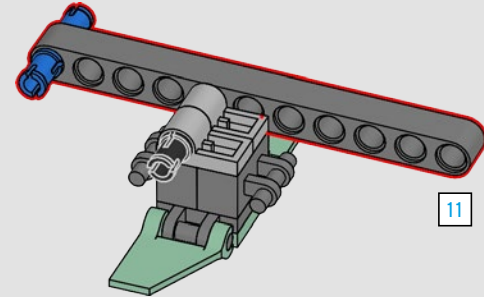

11

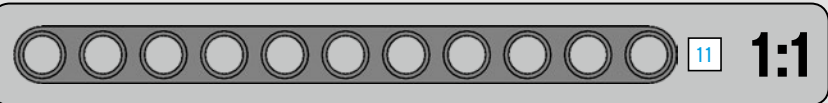

11

1:1

307

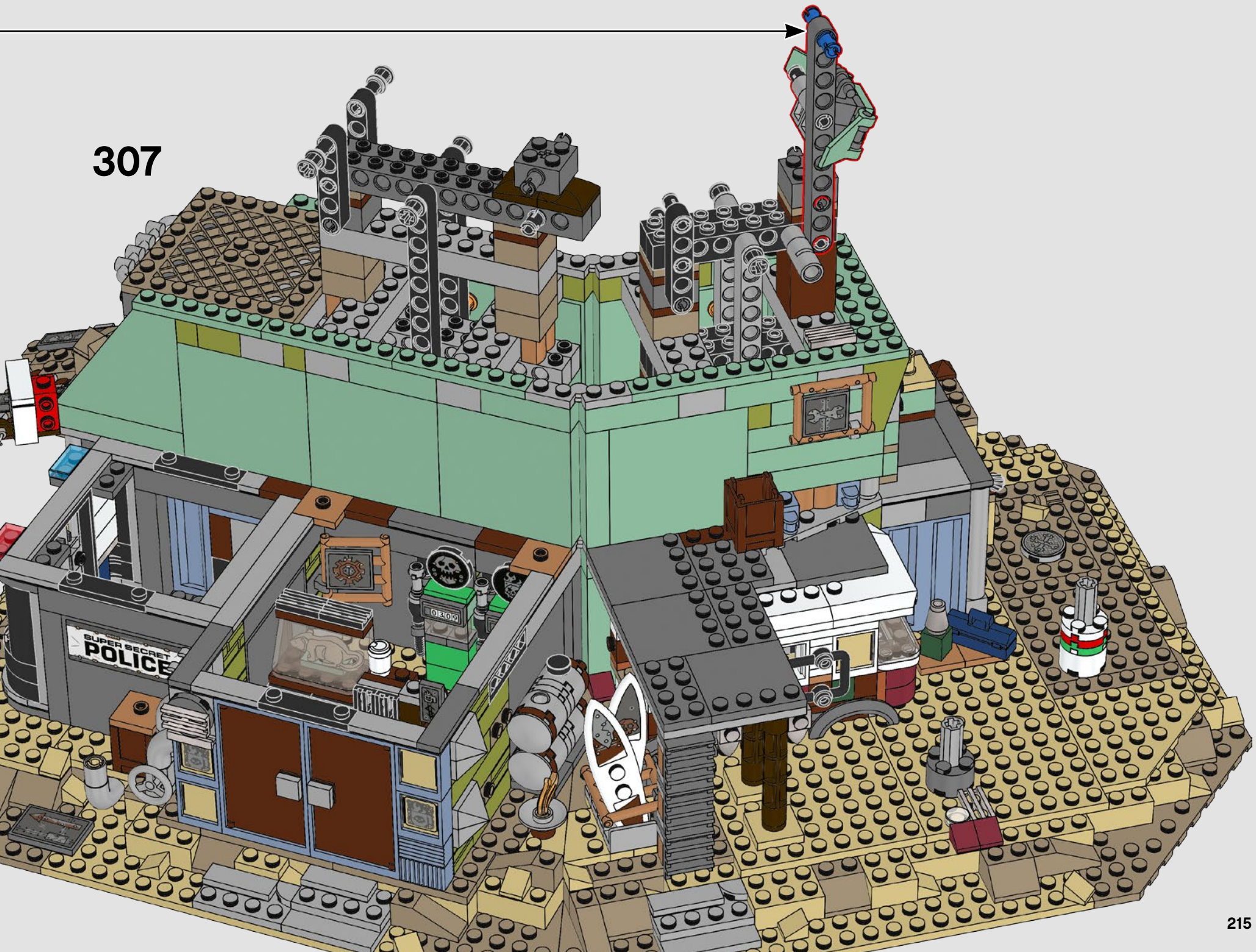

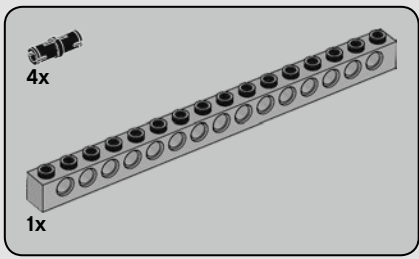

308

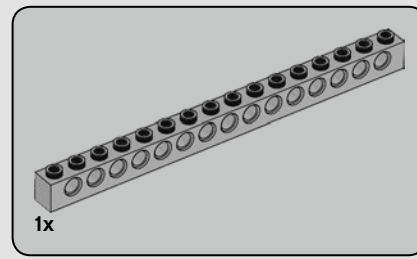
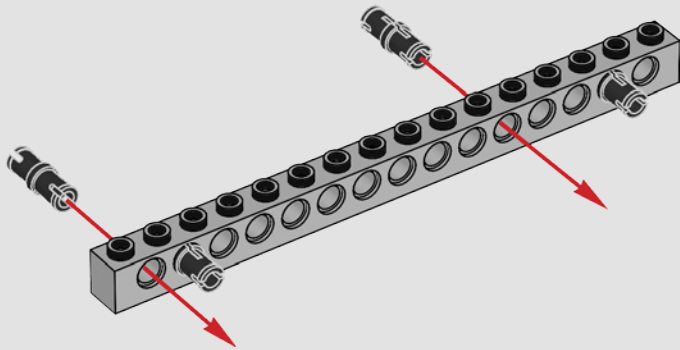

309

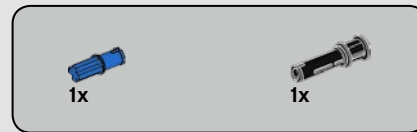
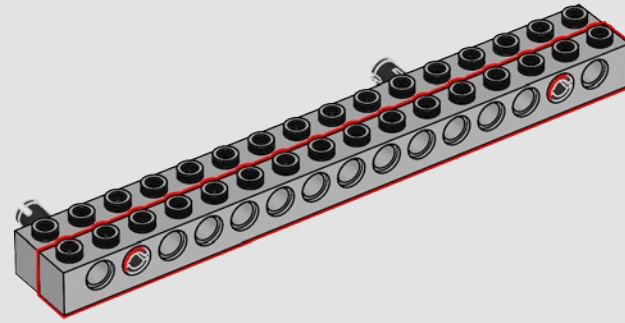

310

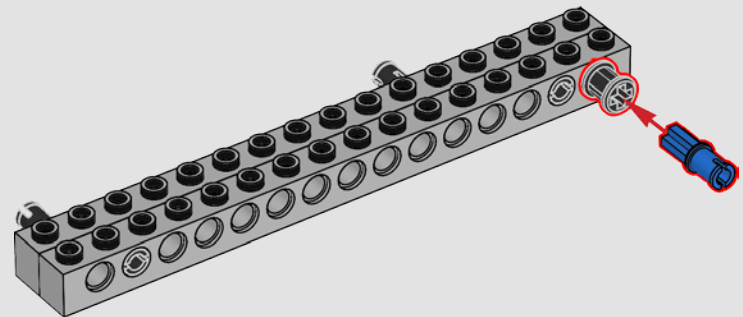



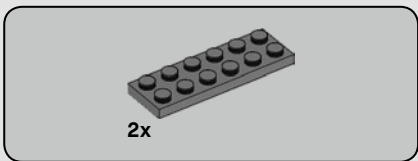

**311**

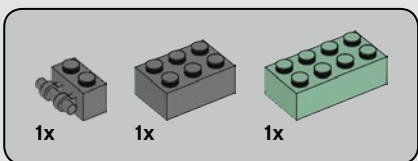
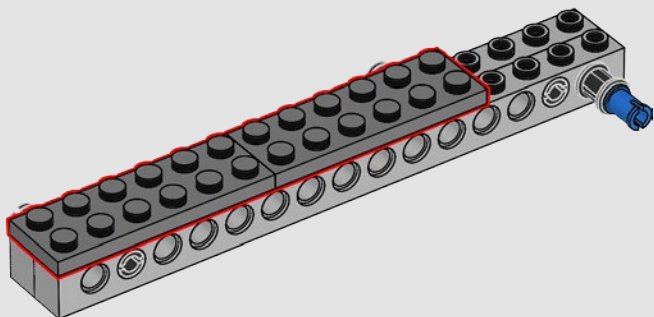

**312**

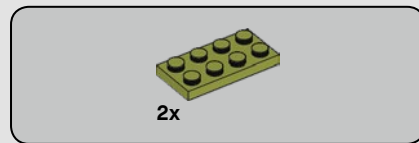
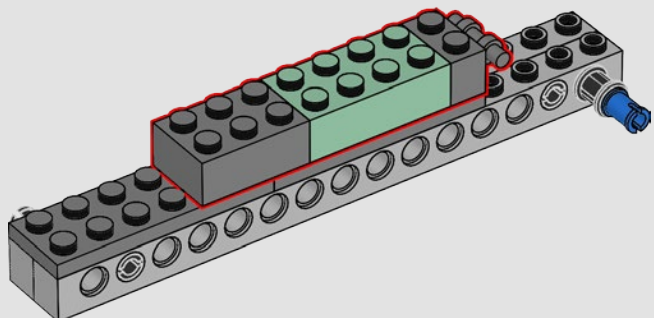

**313**

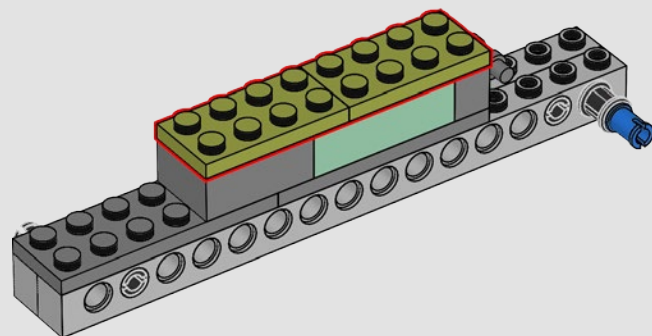

314

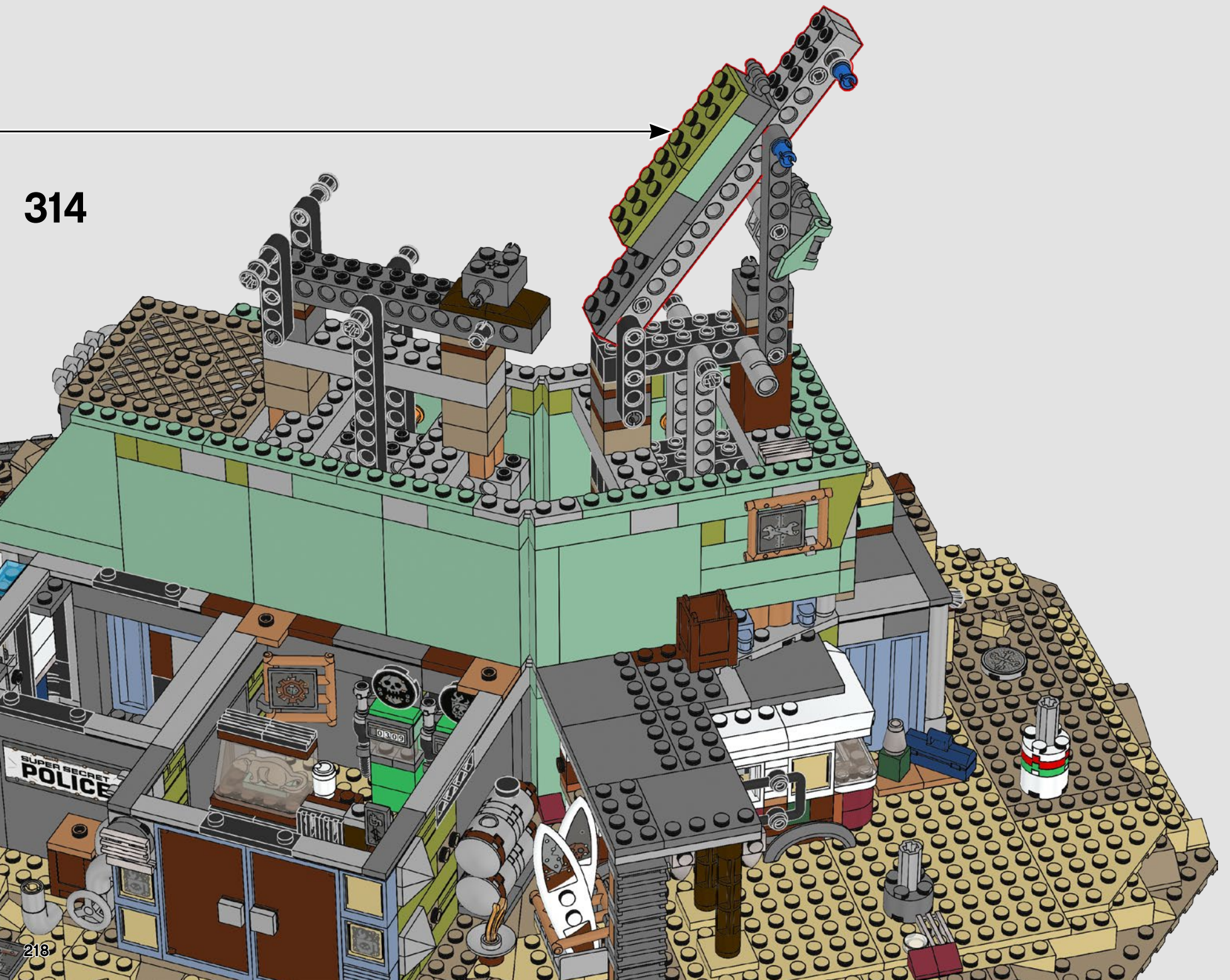

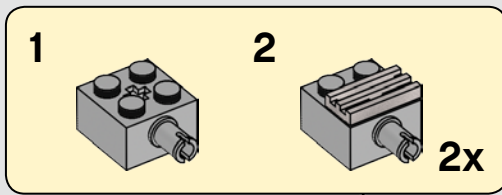
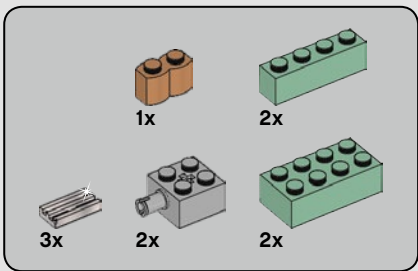

315



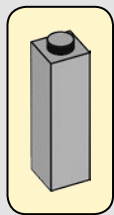
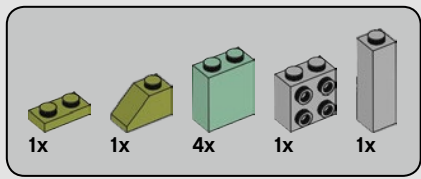

316

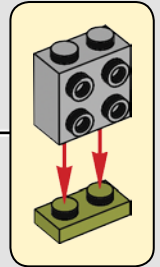
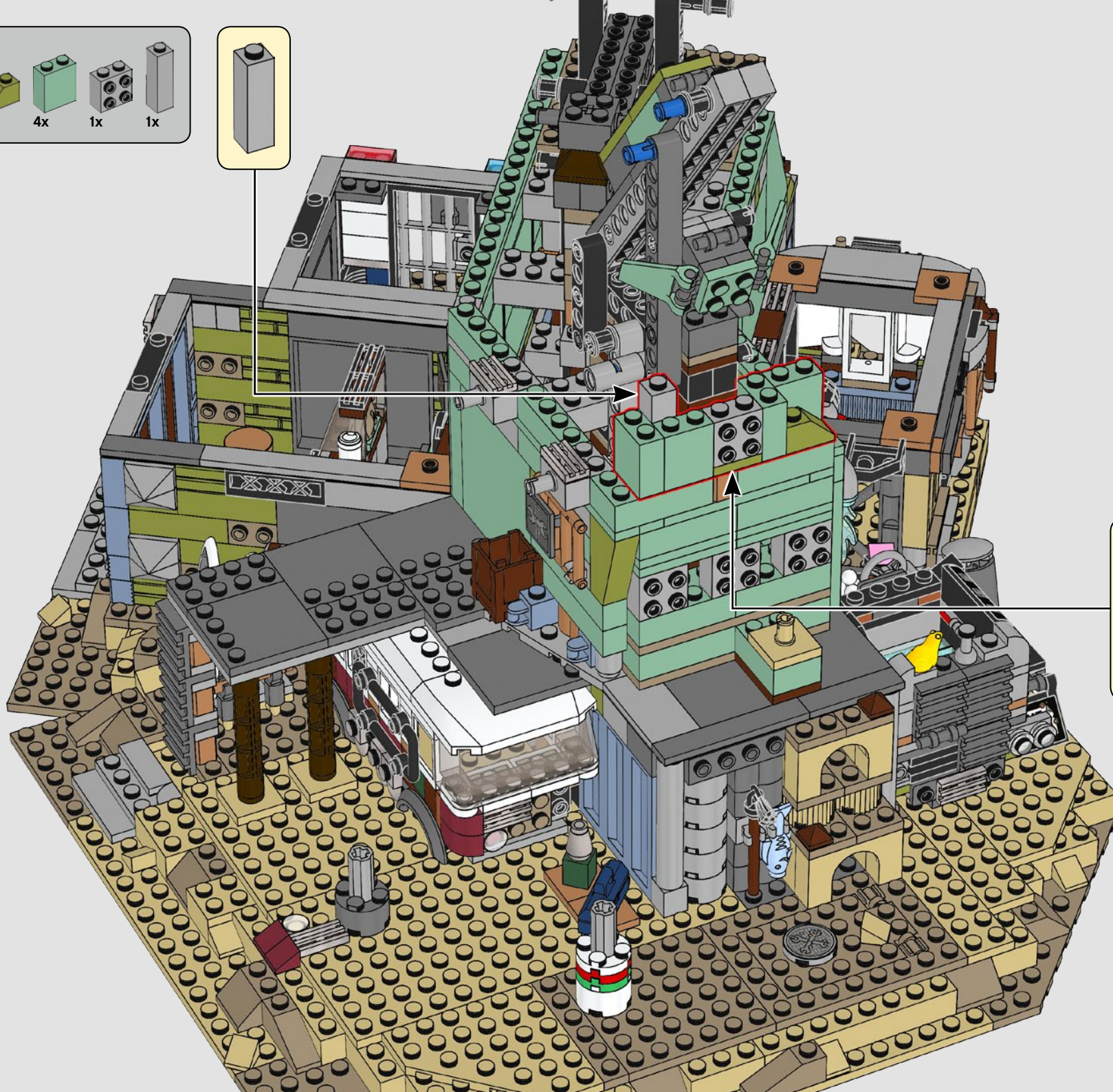

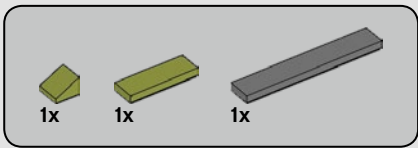

317

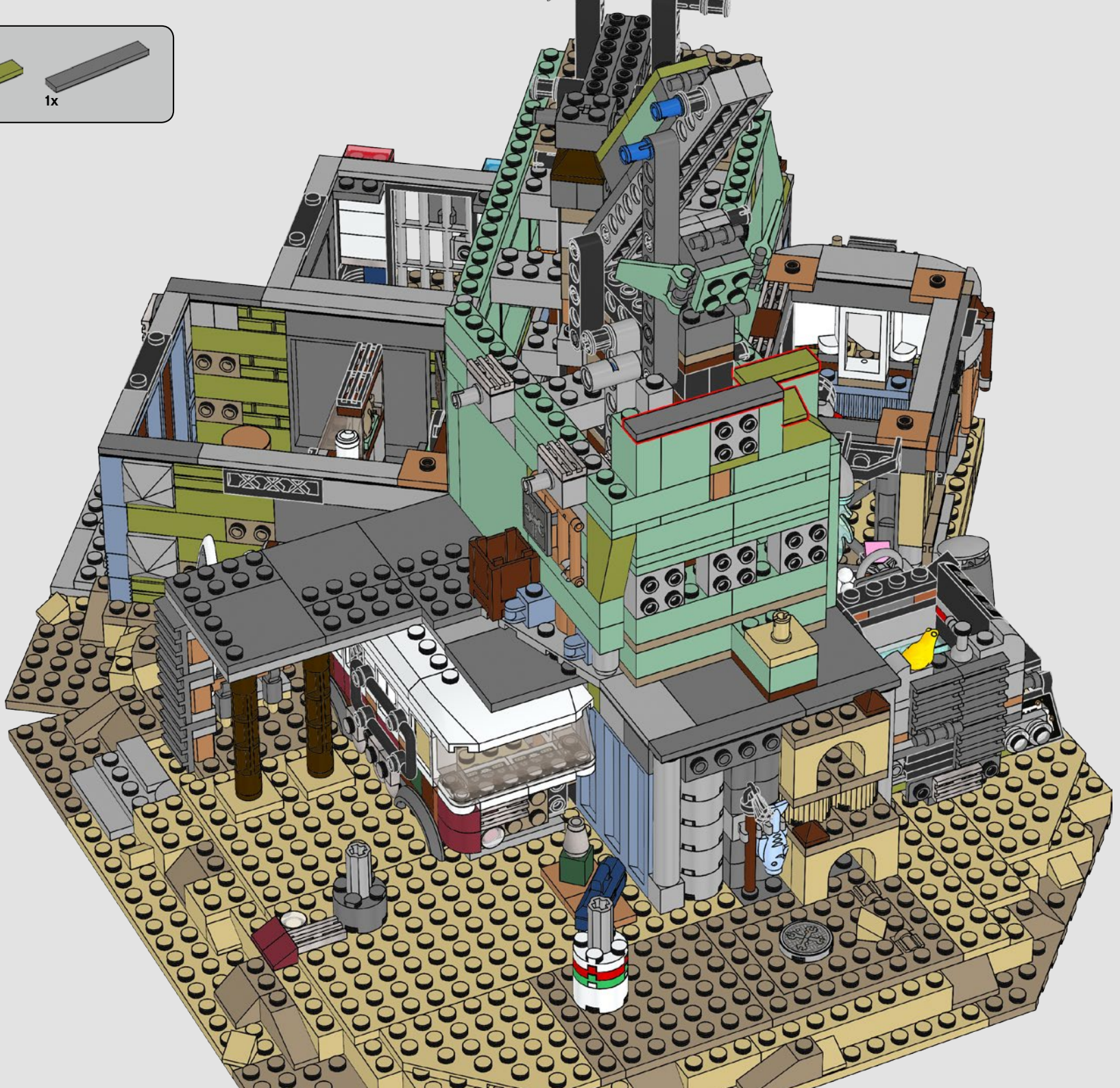

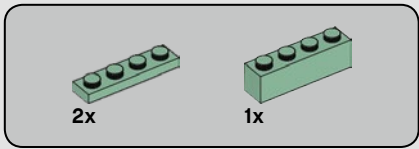

318

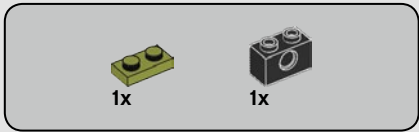
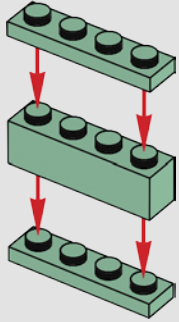

319

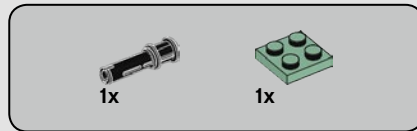
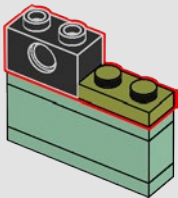

320

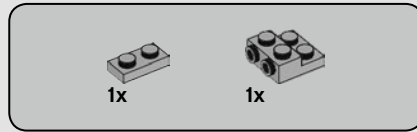
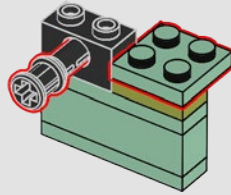

321

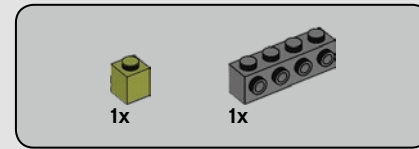
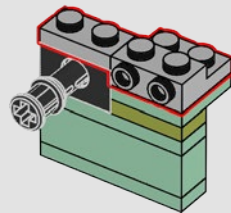

322

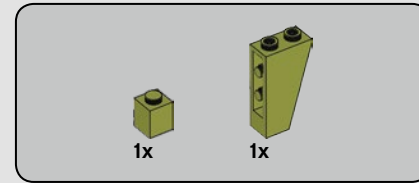
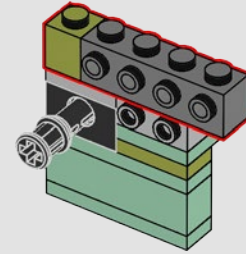

323

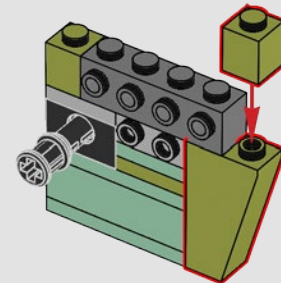

324

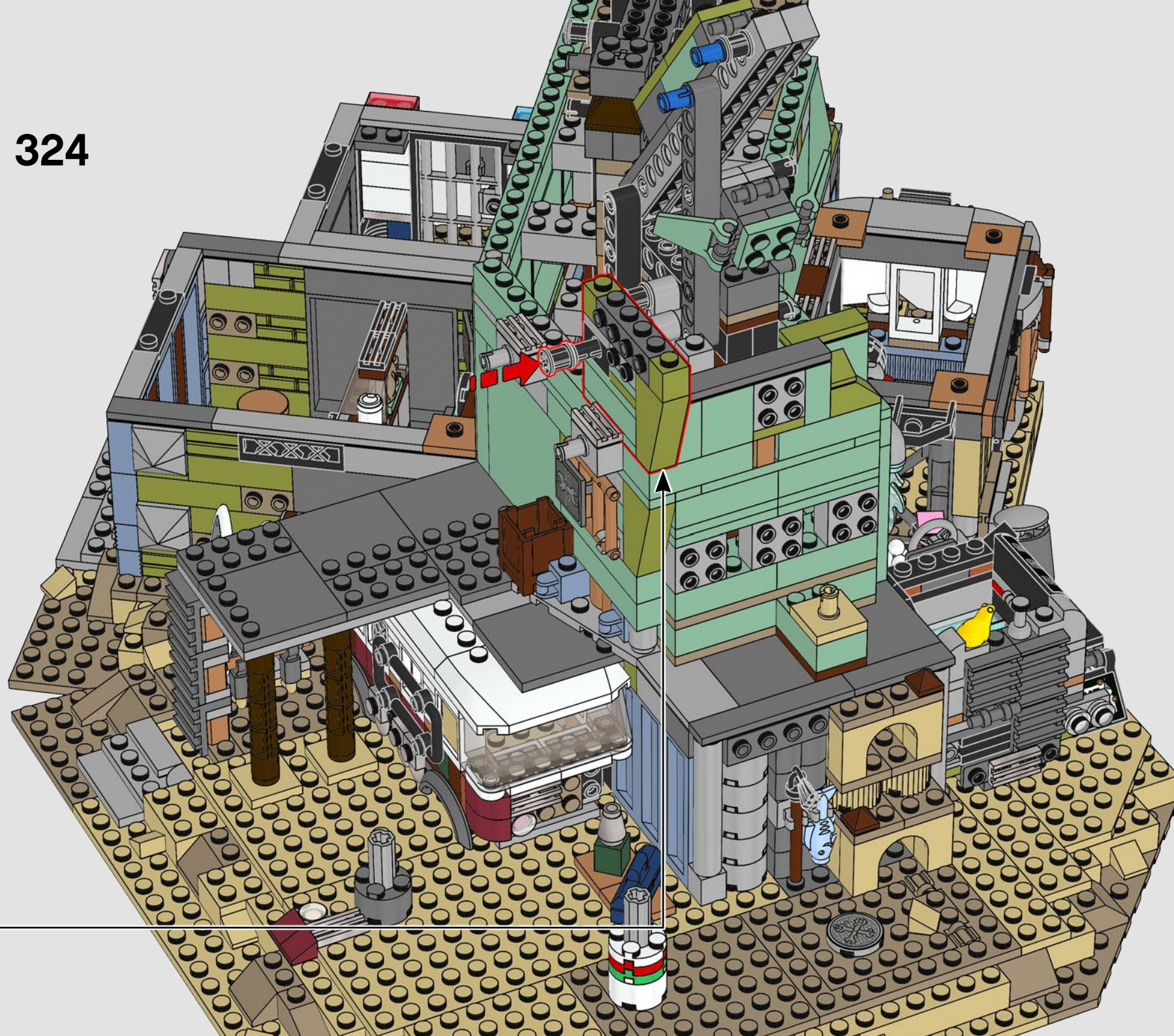

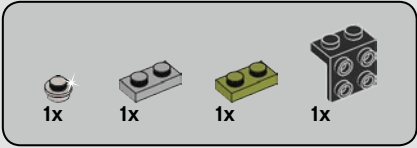

# 325

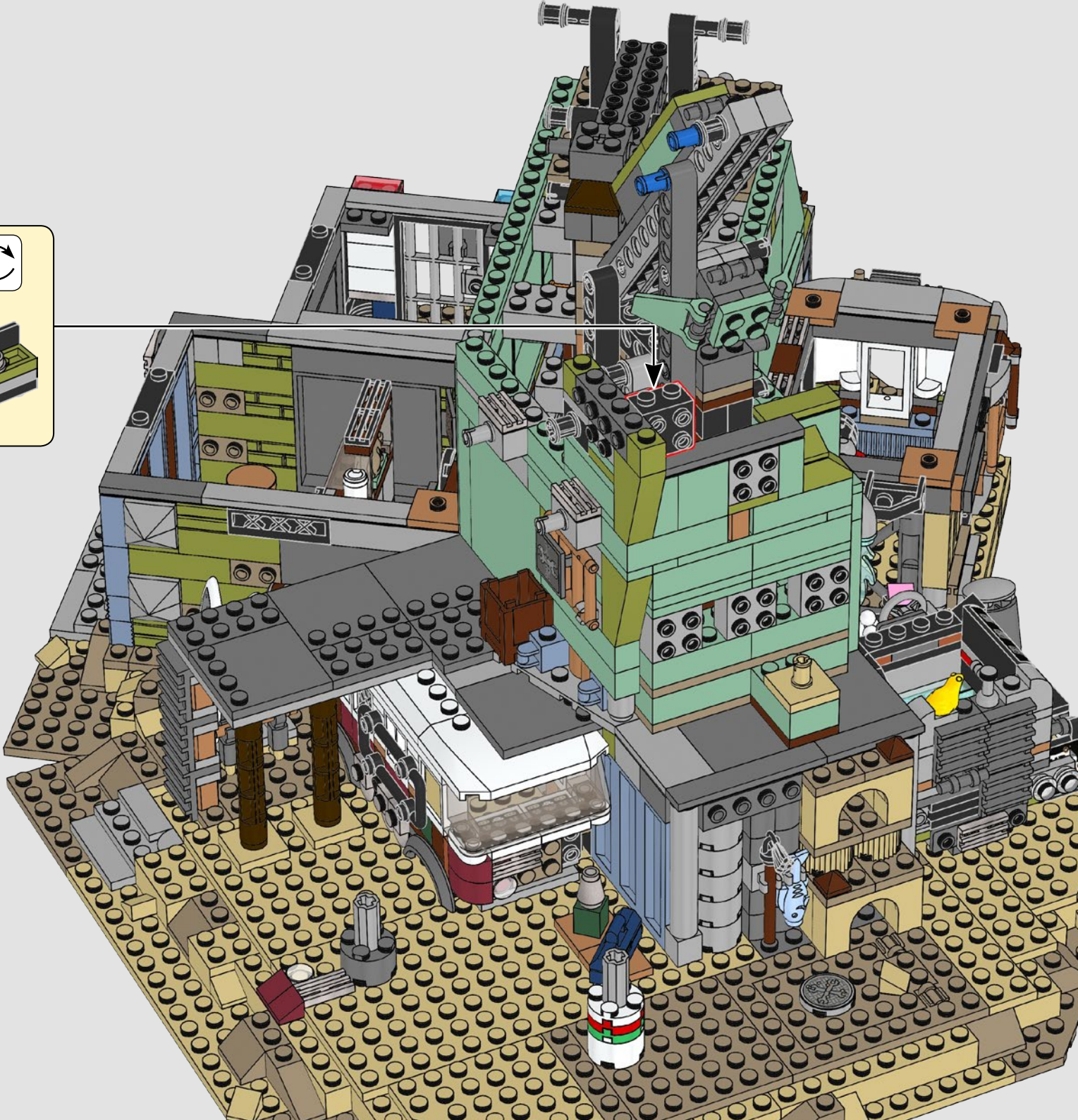
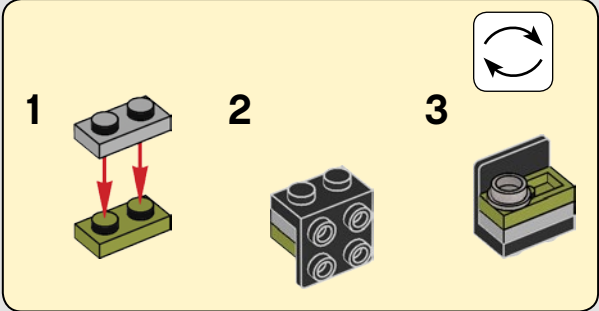



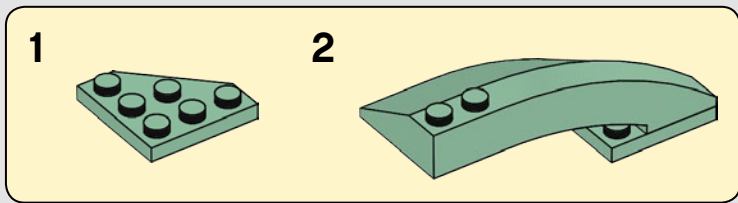
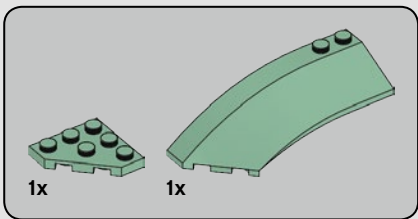

326

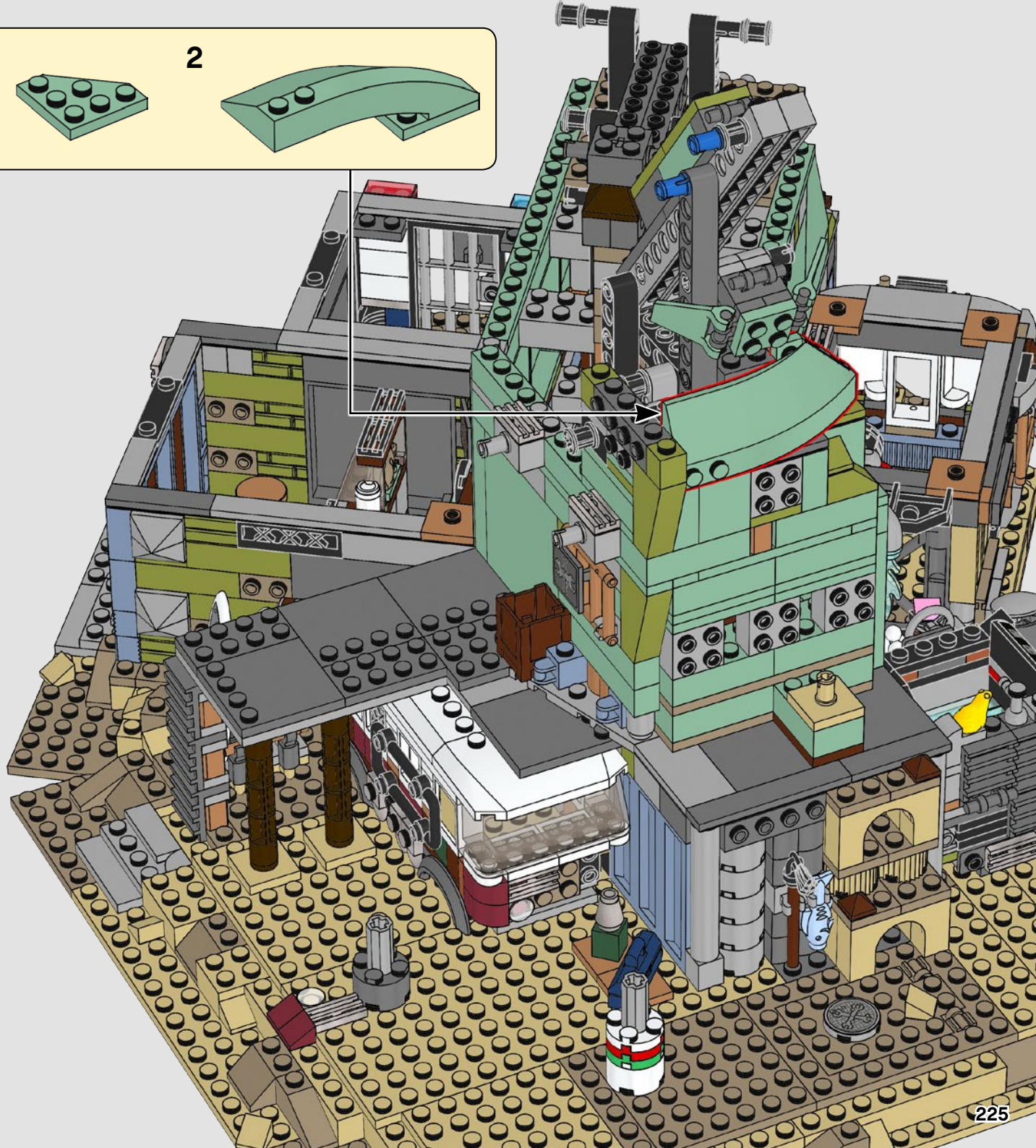

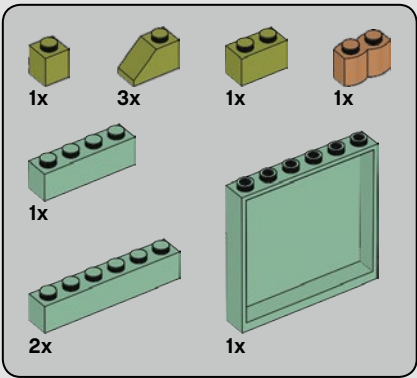

327

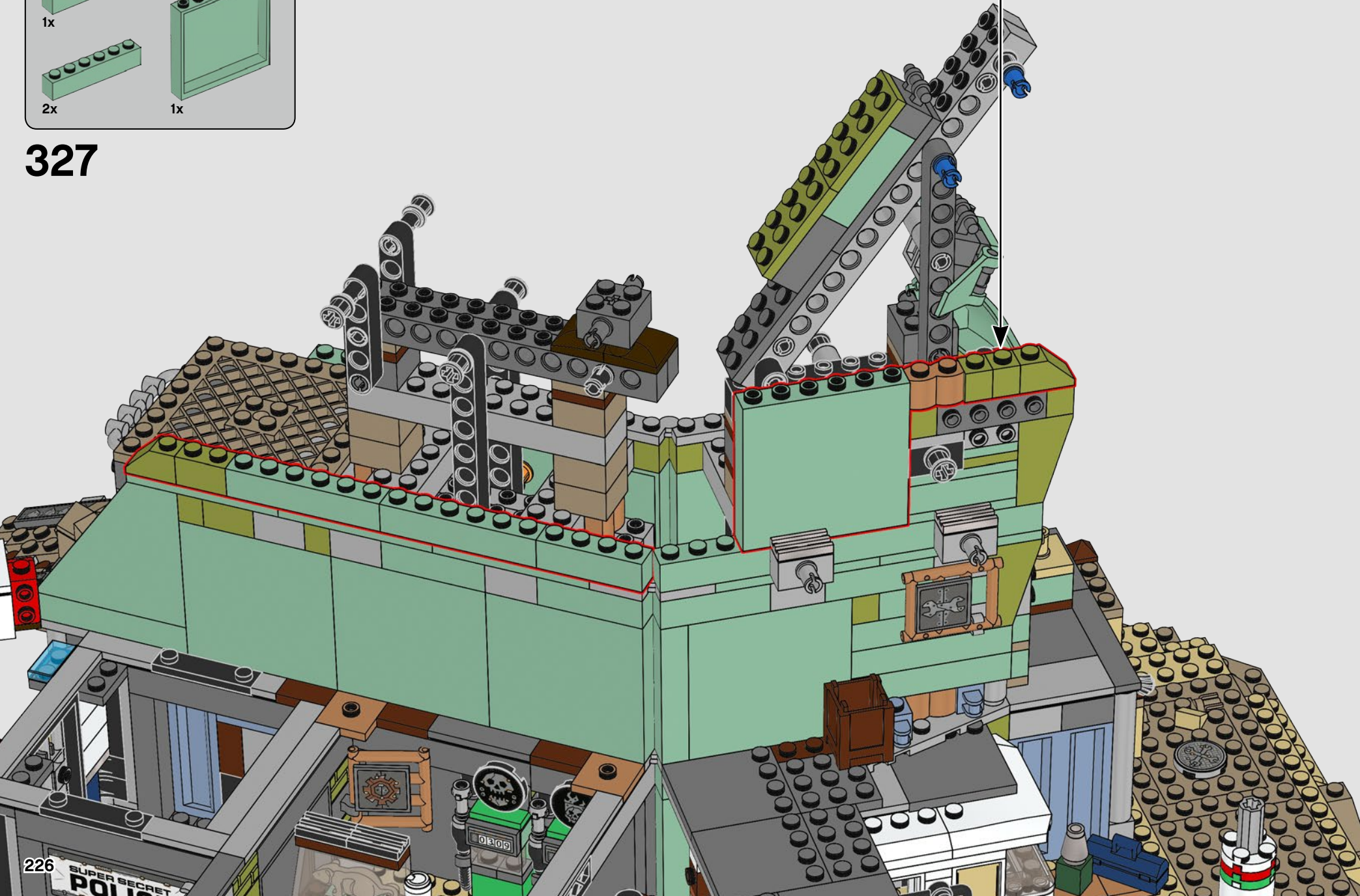
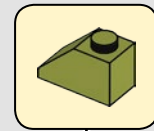

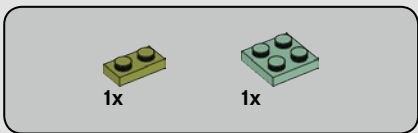

328

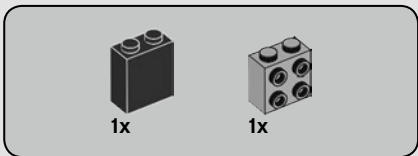
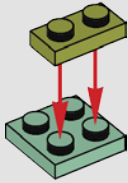

329

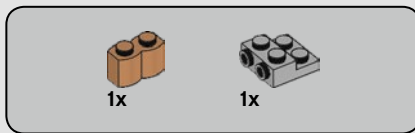
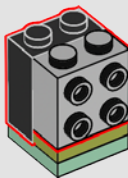

330

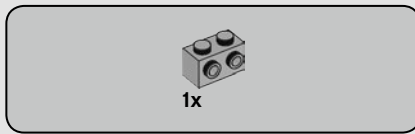
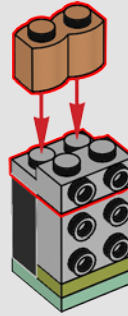

331

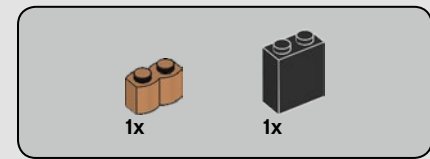
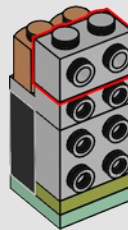

332

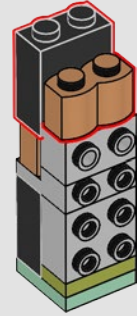

333

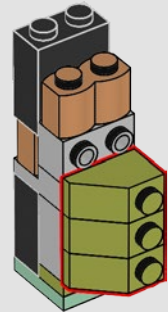

334

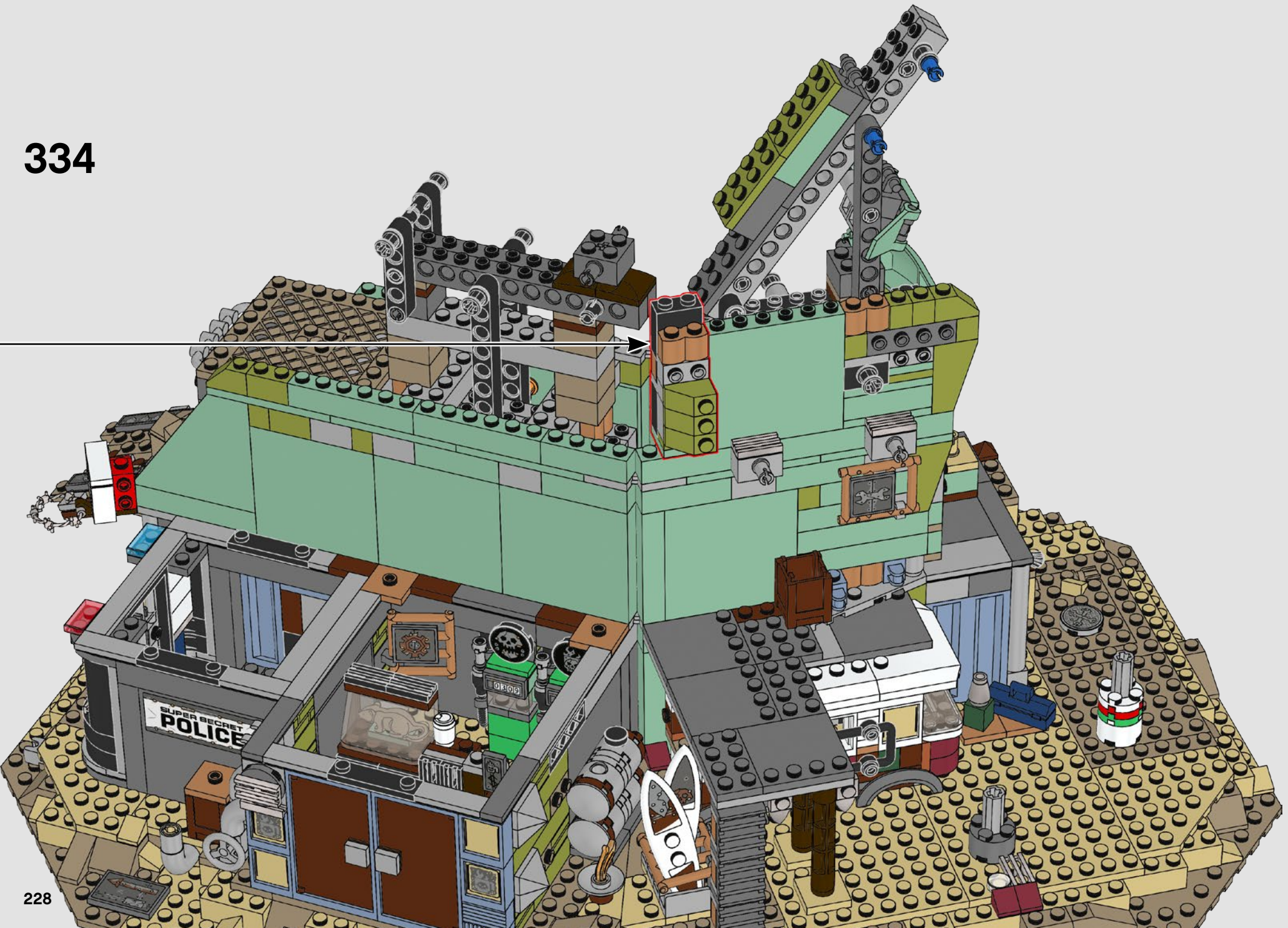

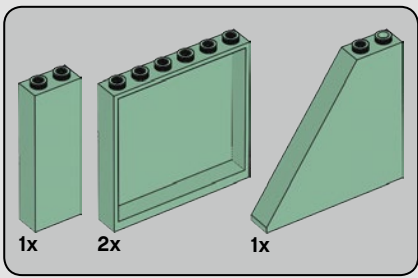

335

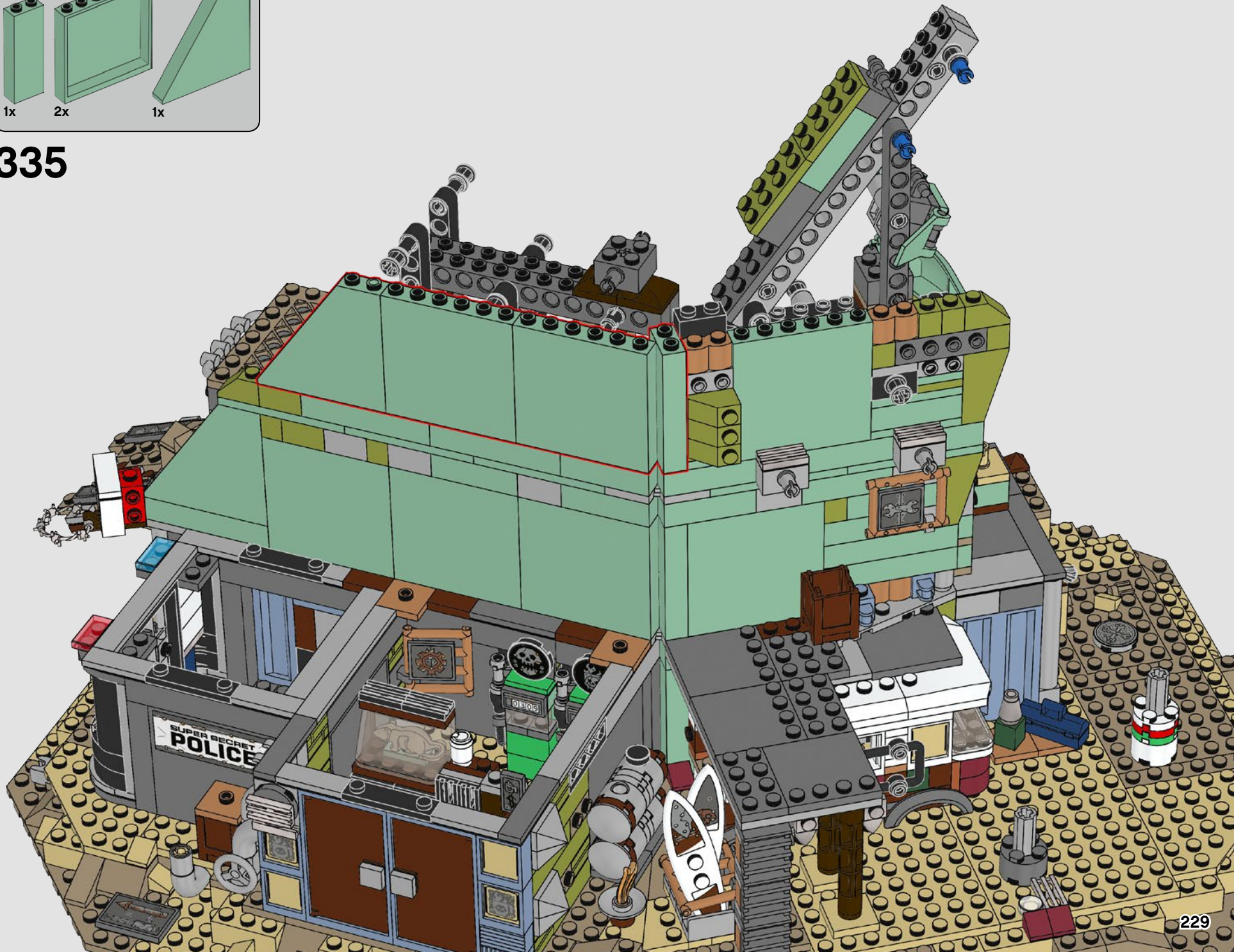

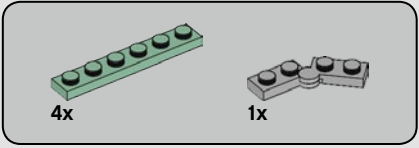

336



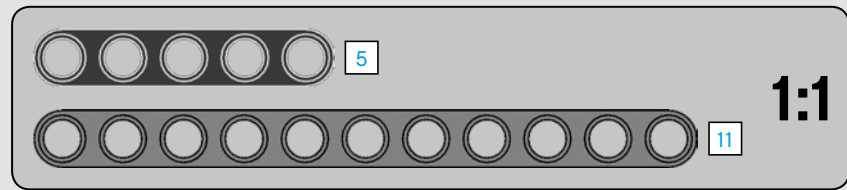
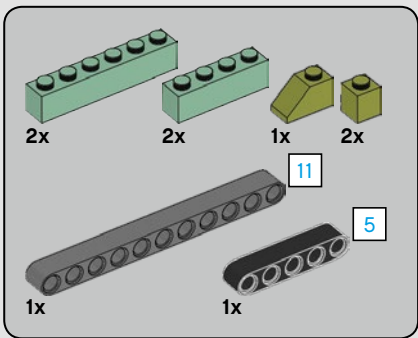

337

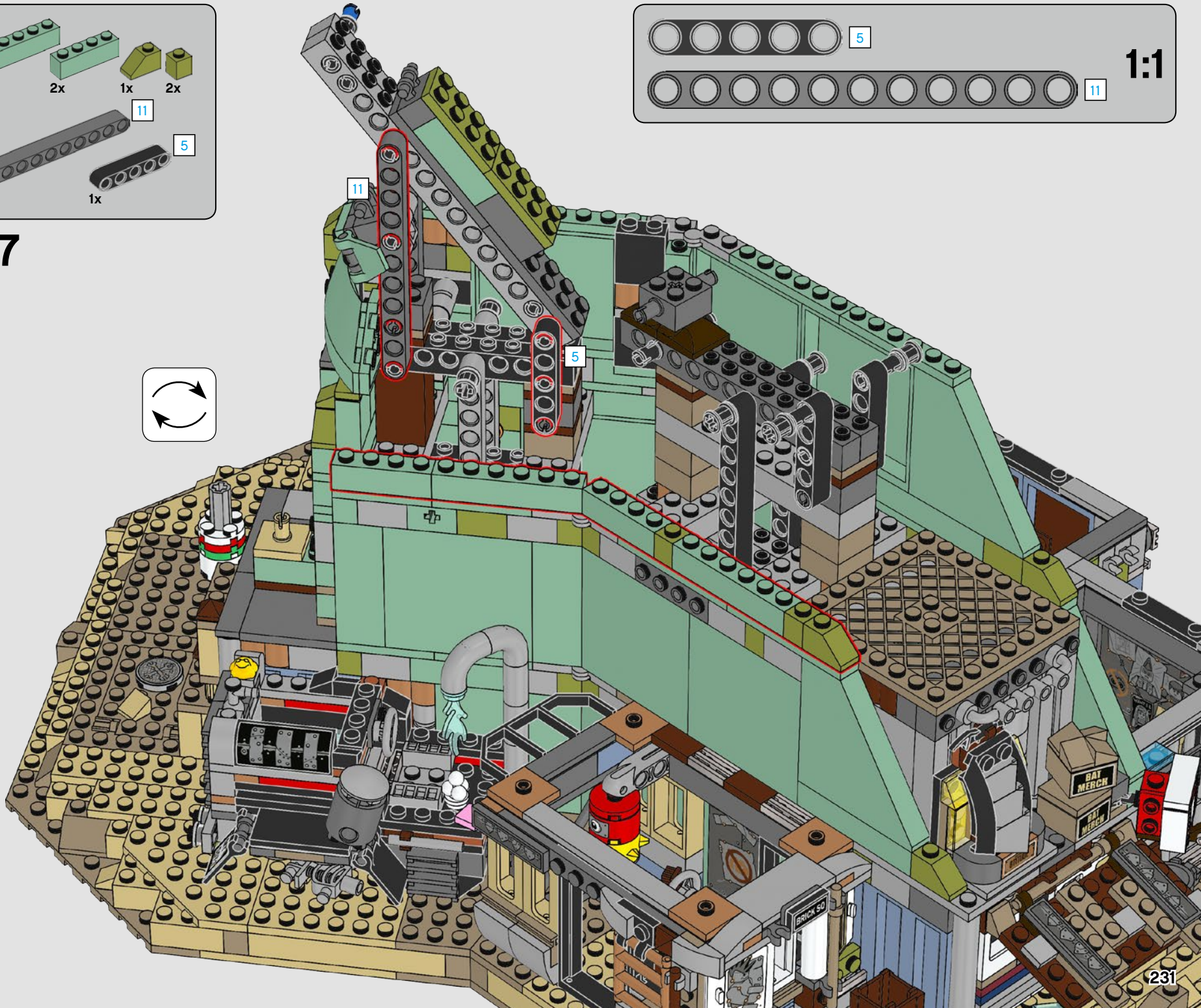
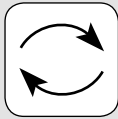

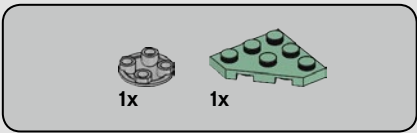

338

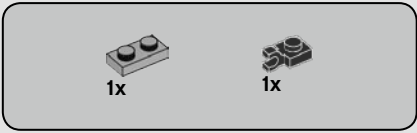
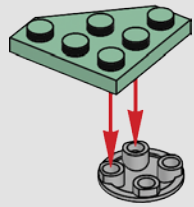

339

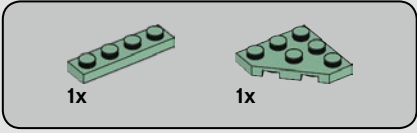
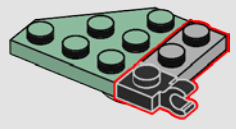

340



341

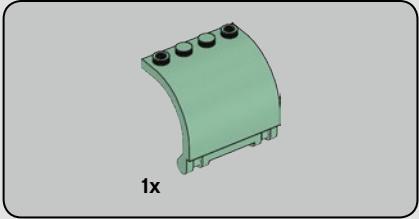
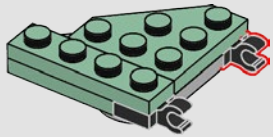

342

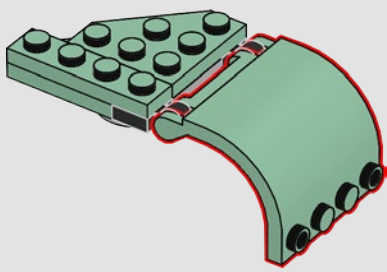



343

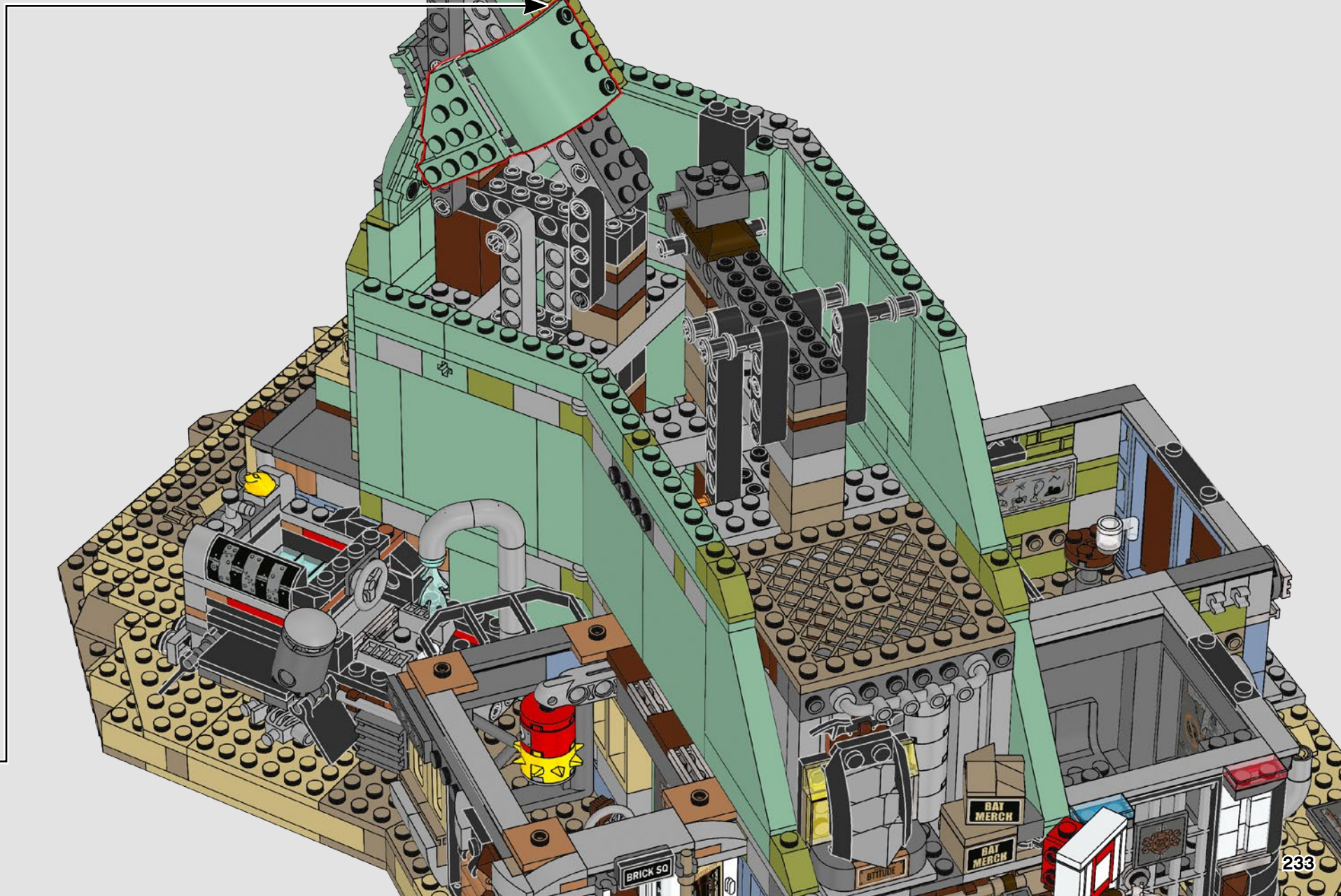

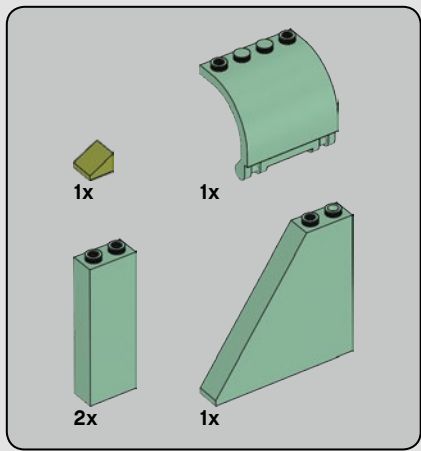

344

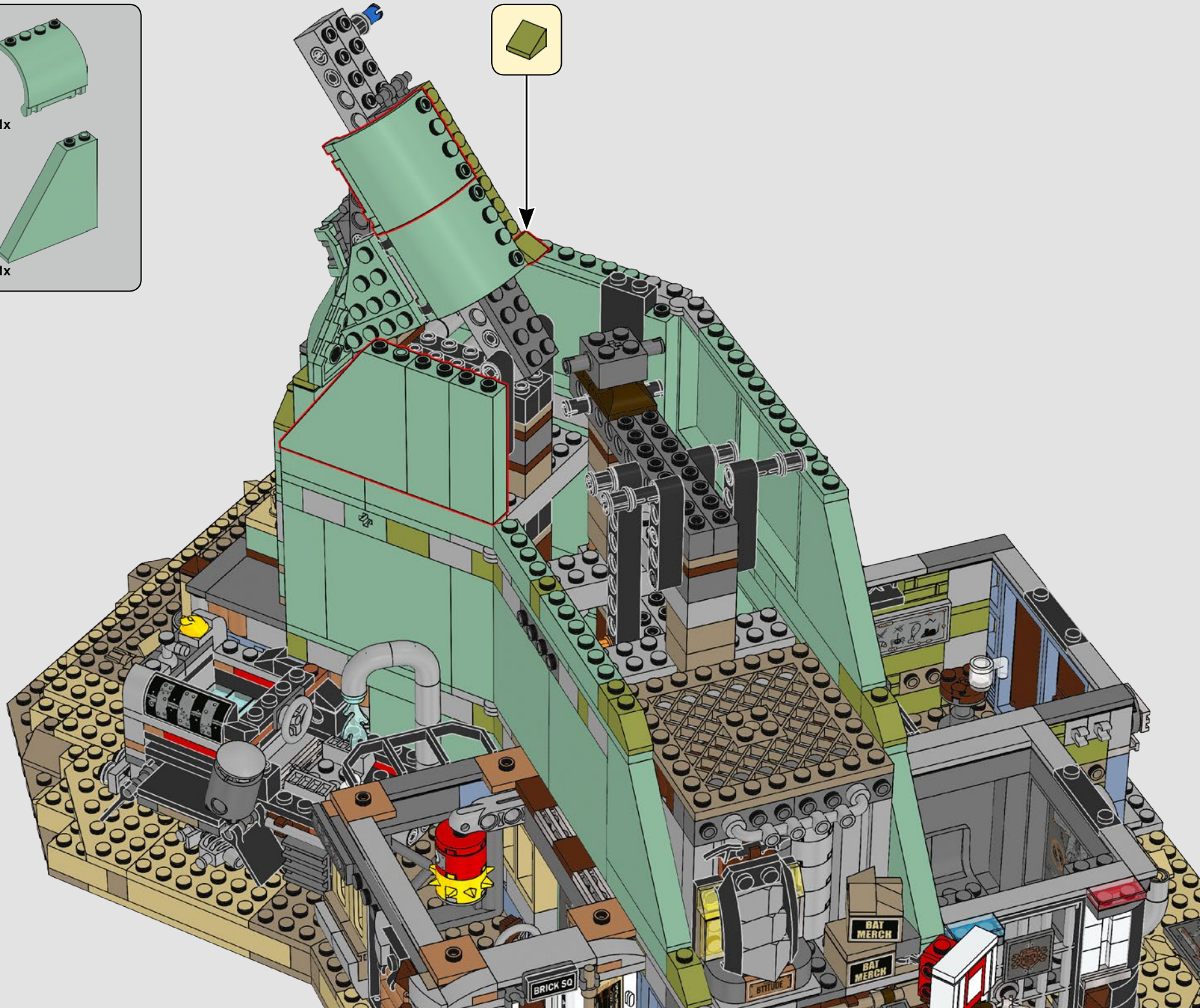

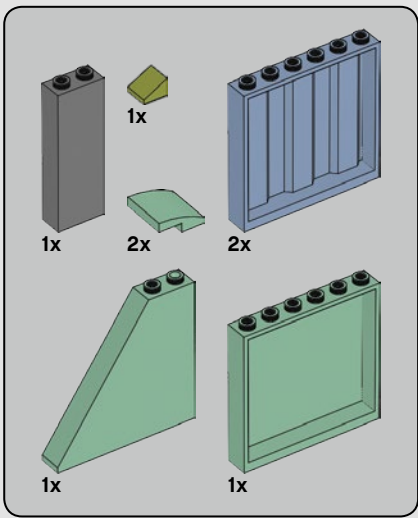

345

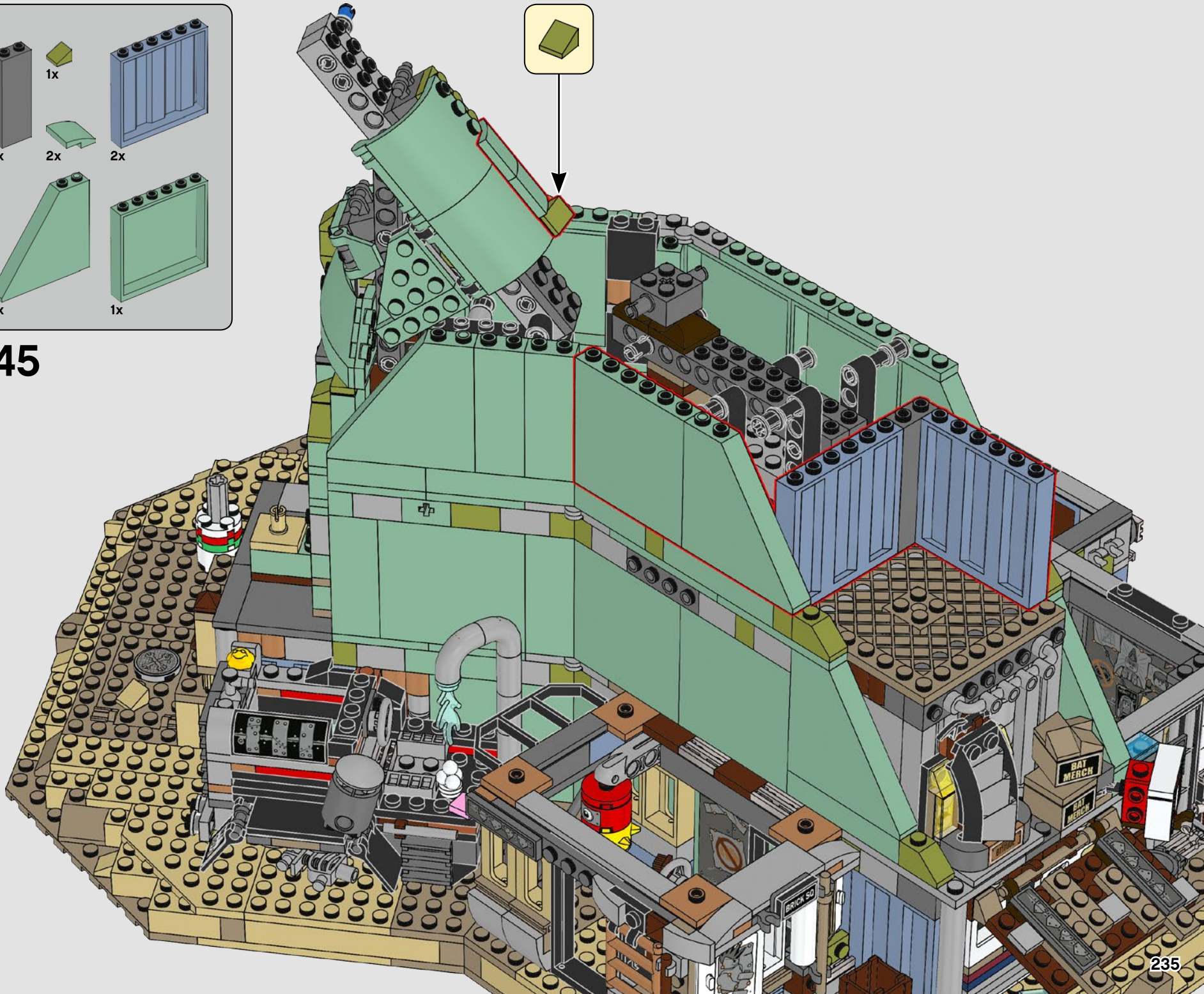

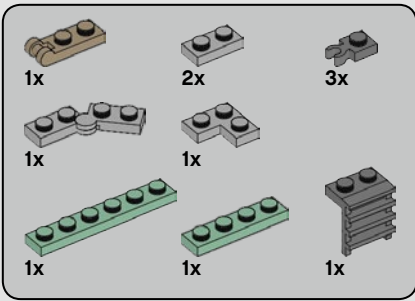

# 346

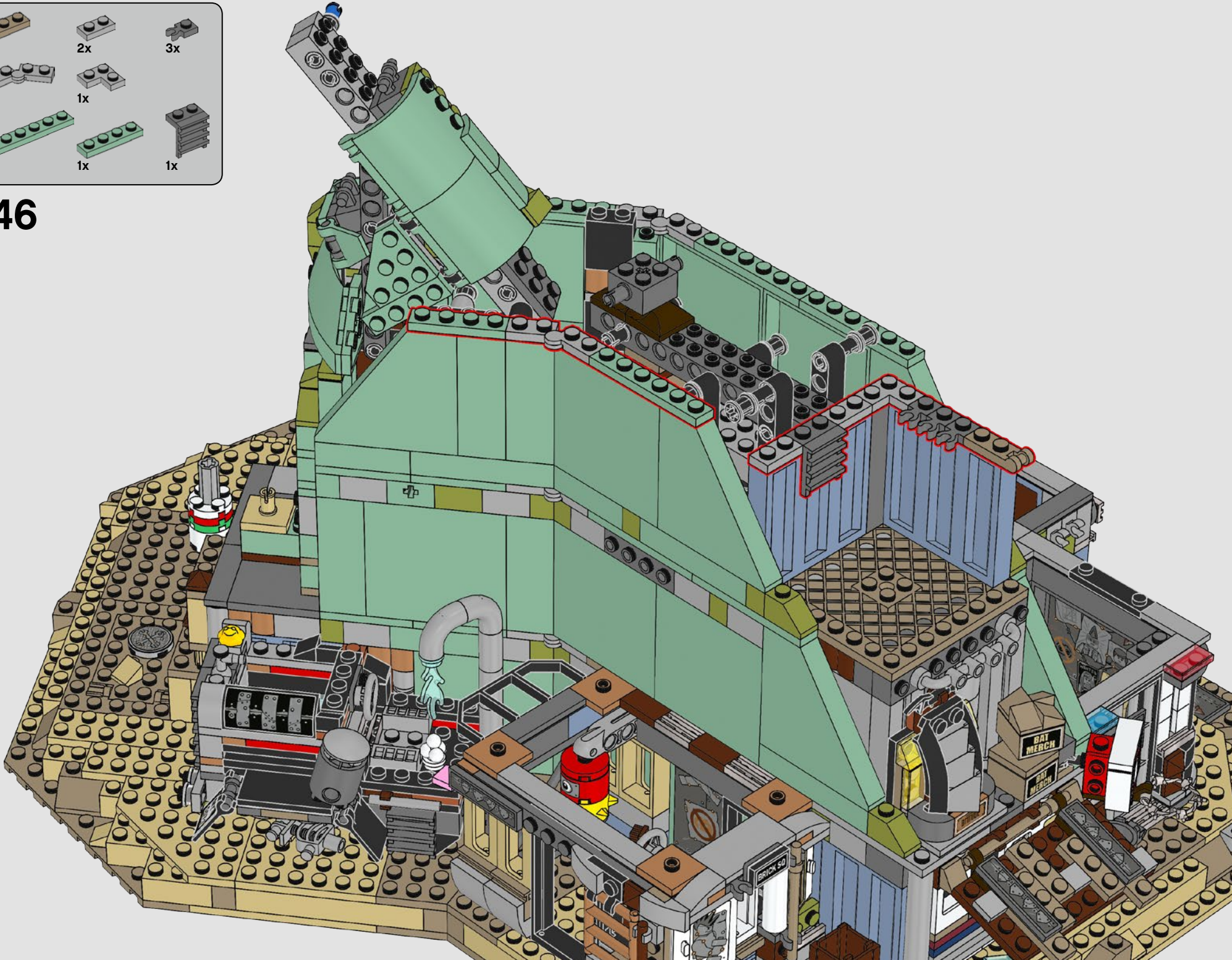

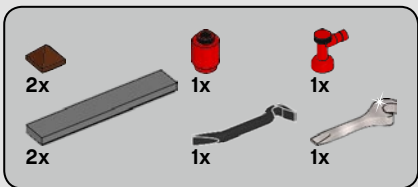

347

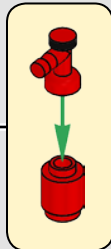
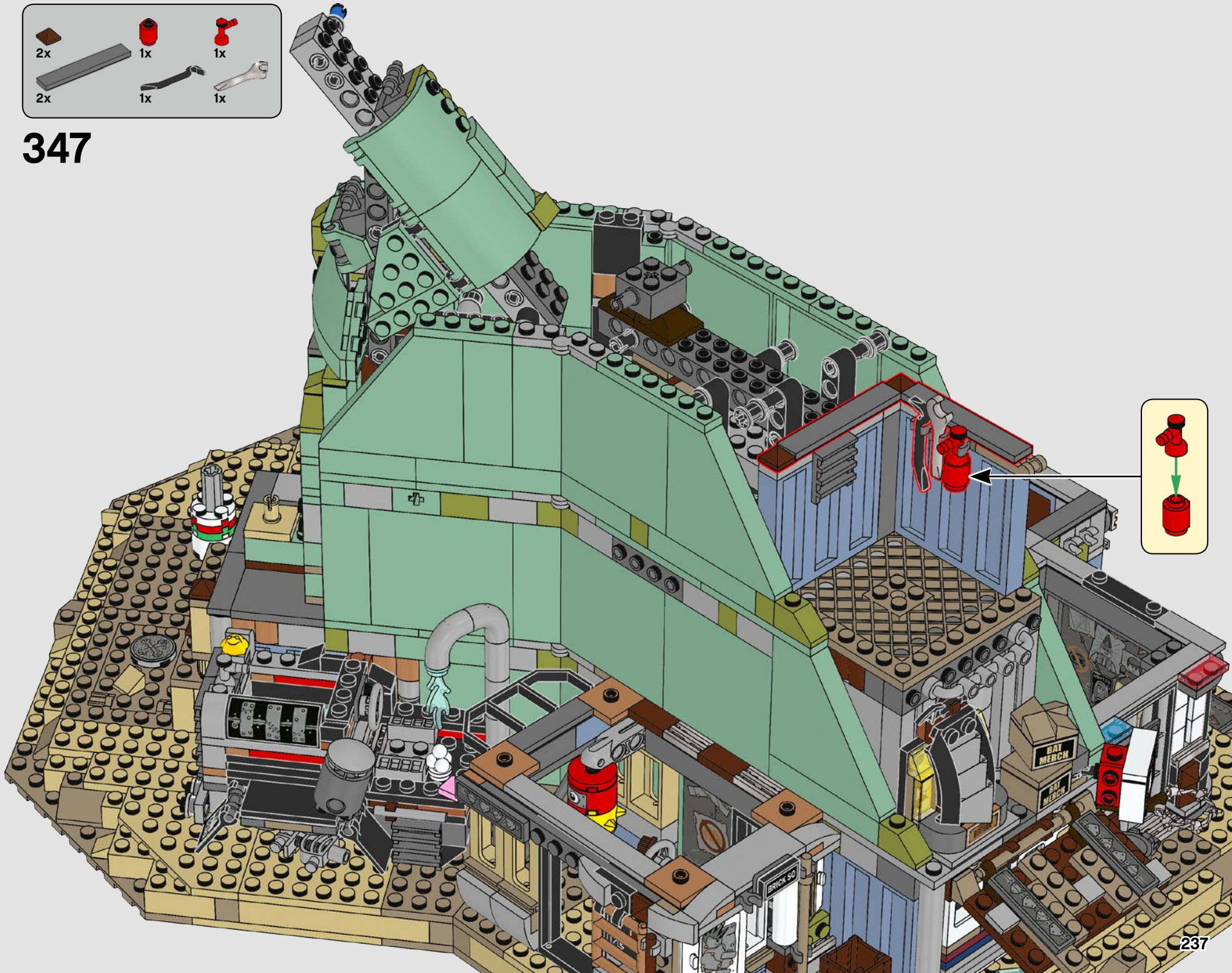

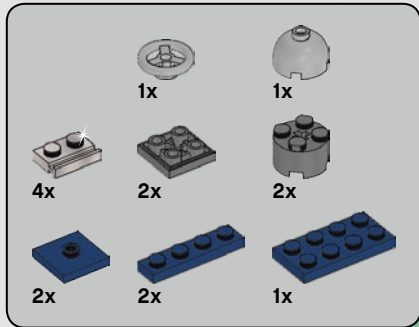

348

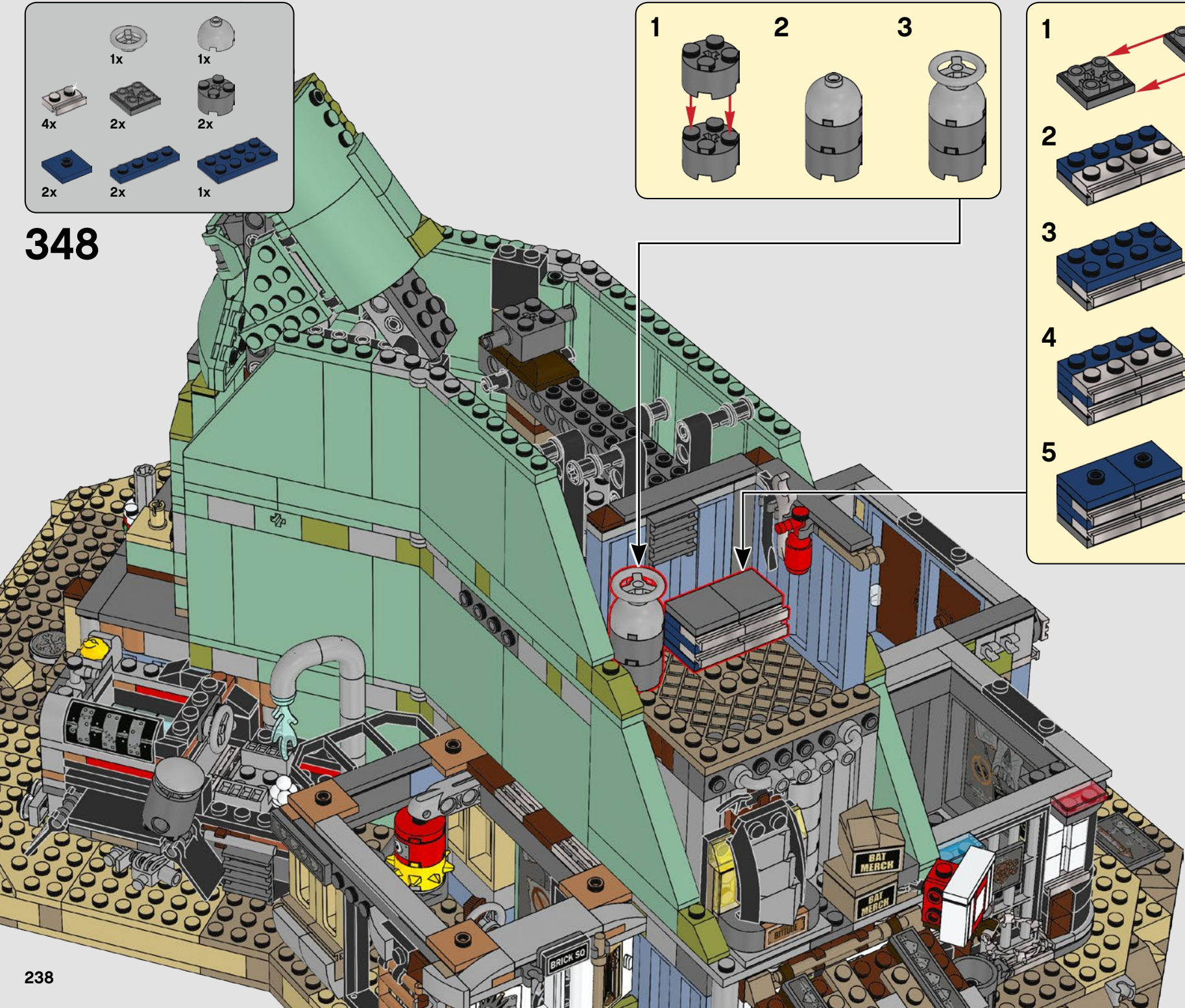
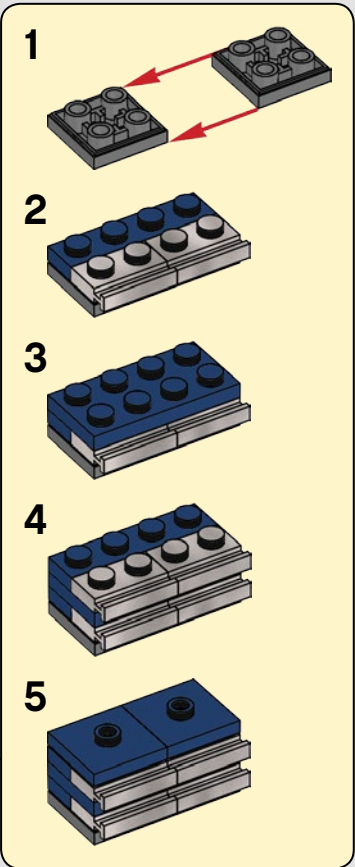
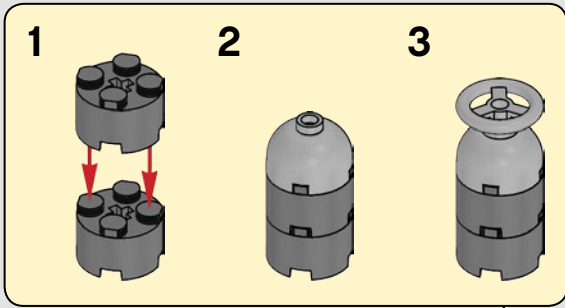

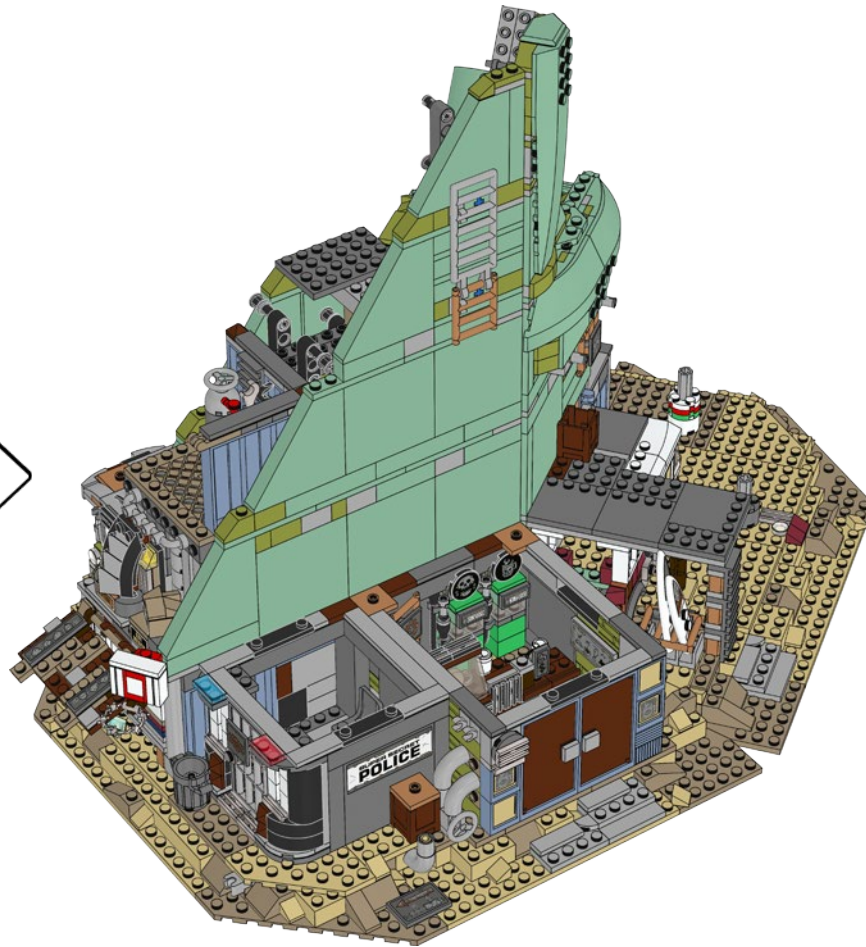
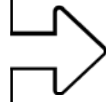

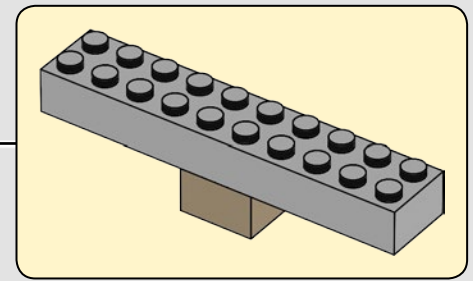
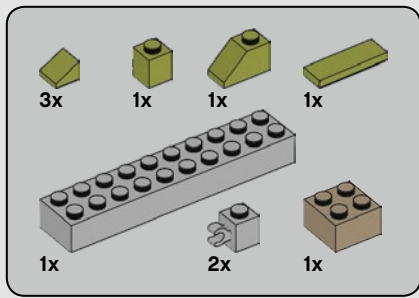

349

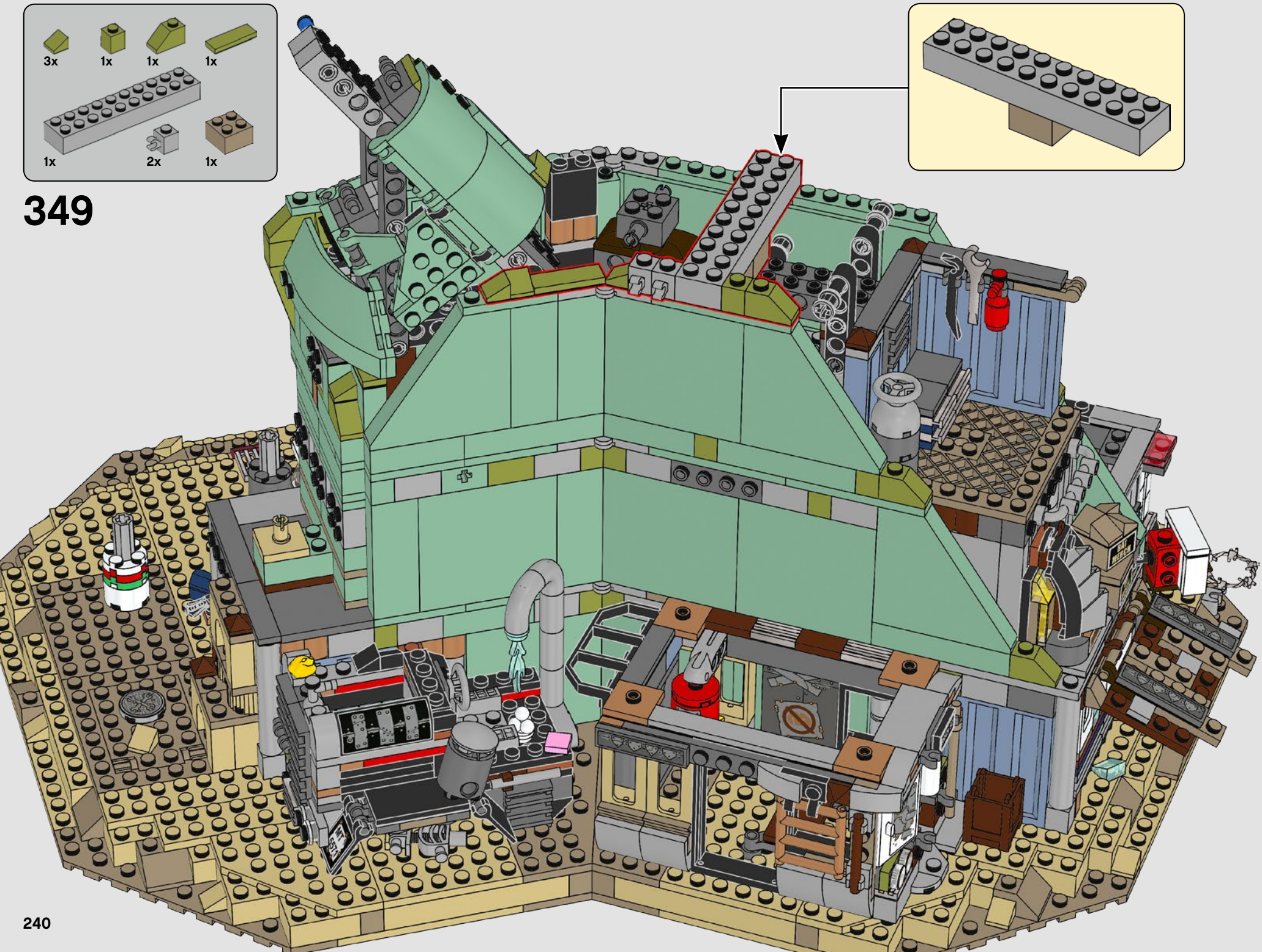



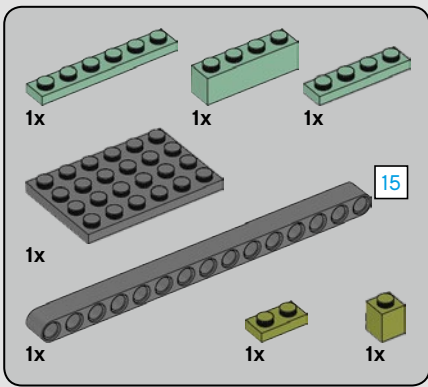

350

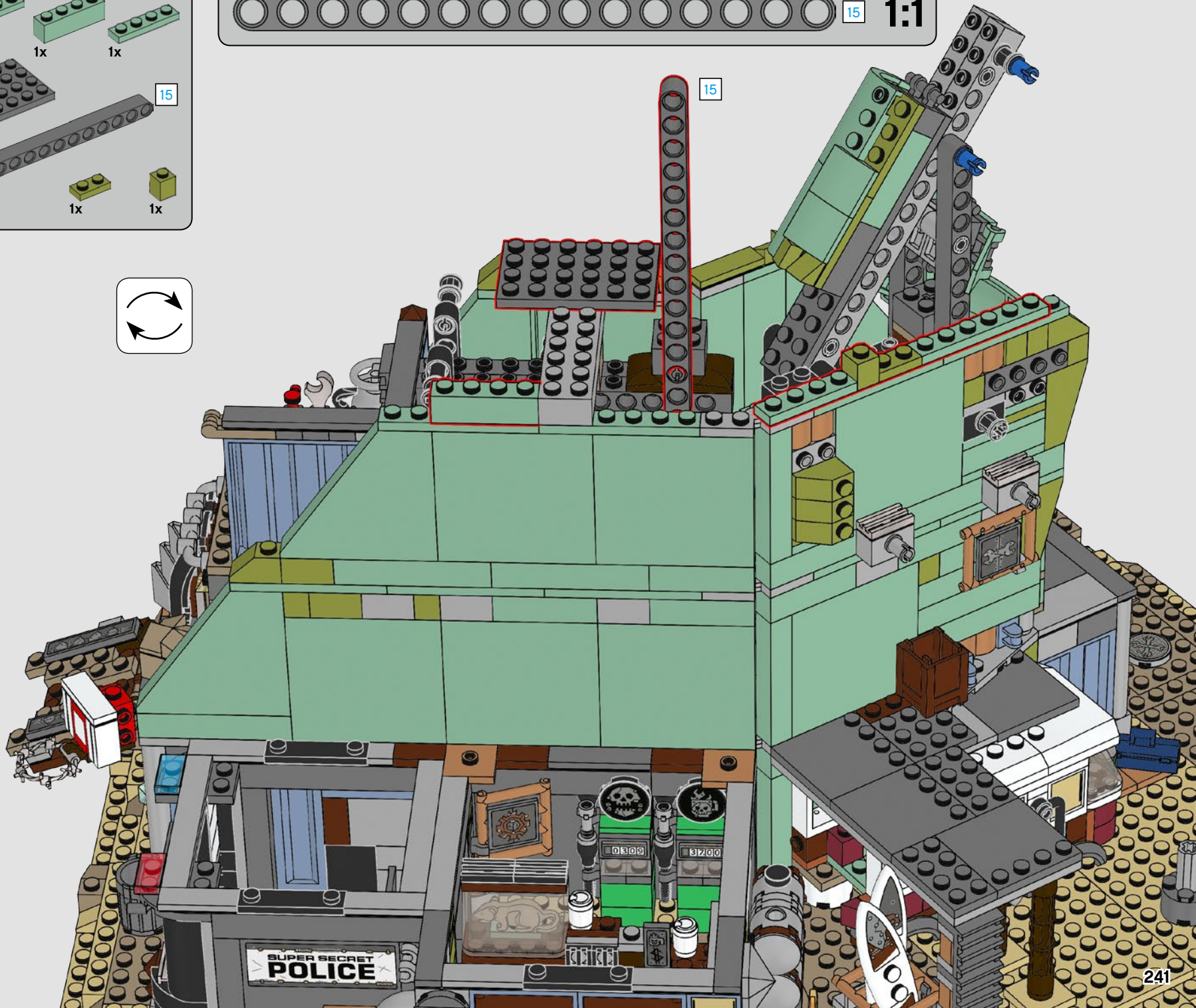
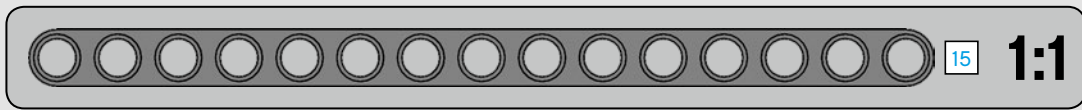
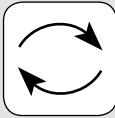

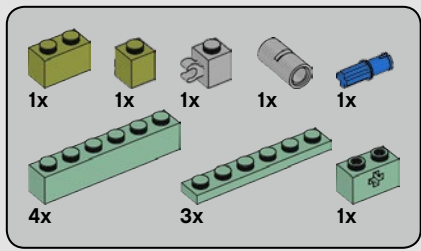

# 351

1

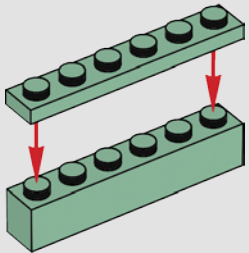

2

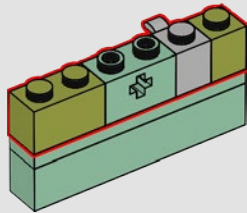

3

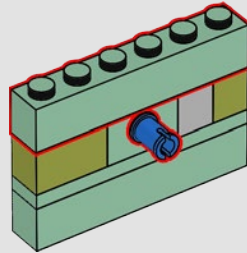

4

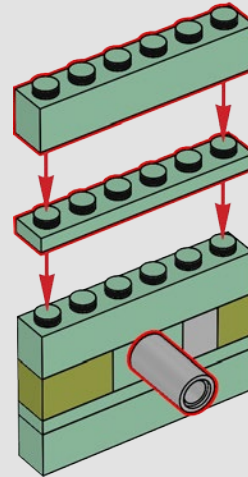

5

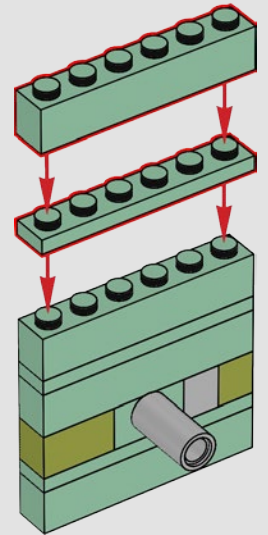

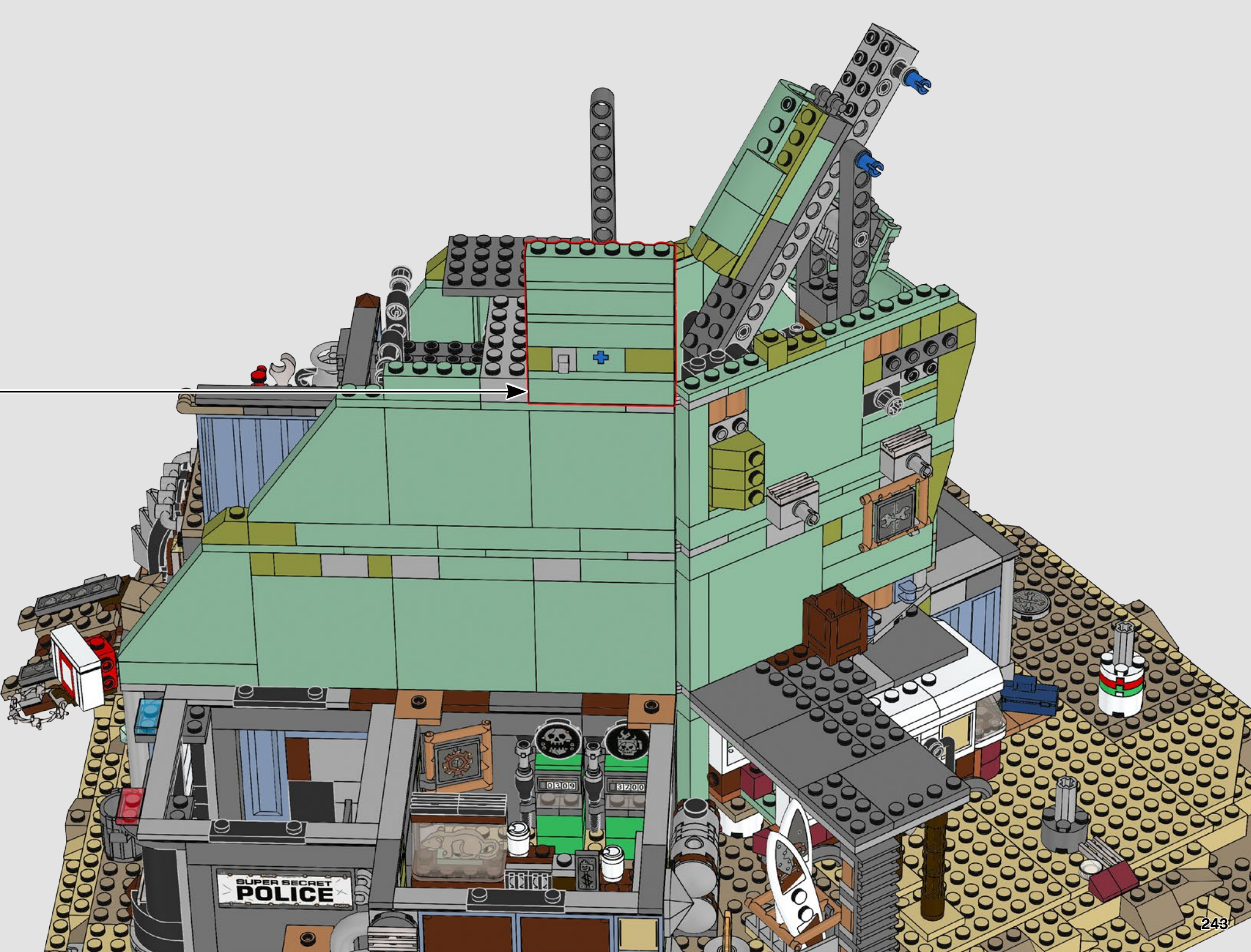

SUPER SECRET  
POLICE

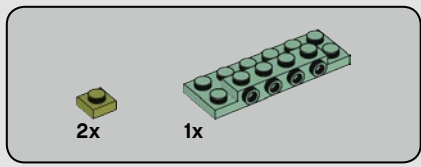

352

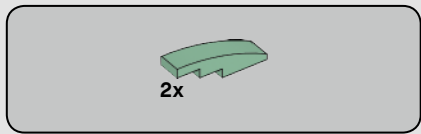
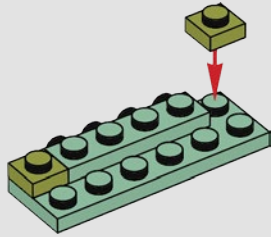

353

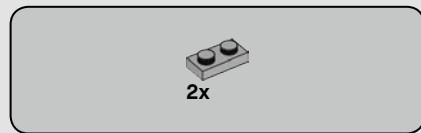
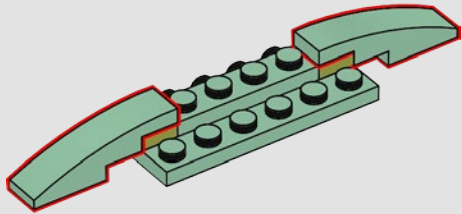

354

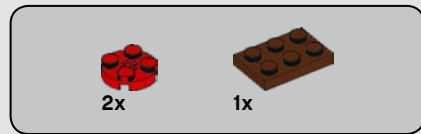
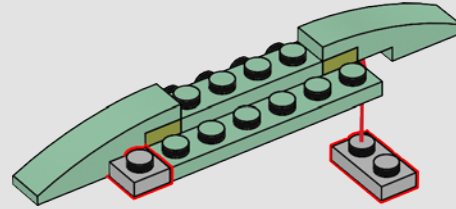

355

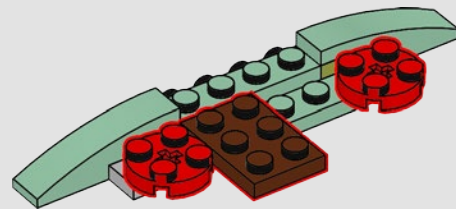

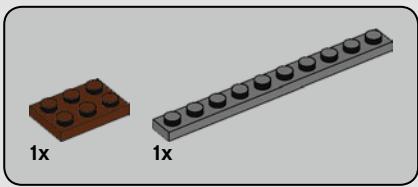

356

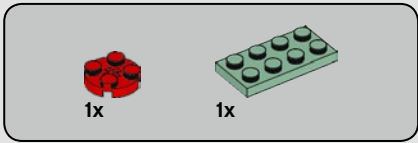
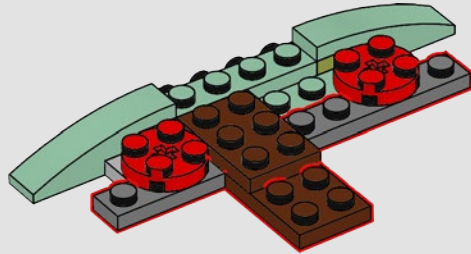

357

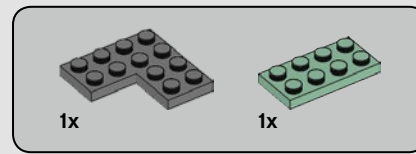
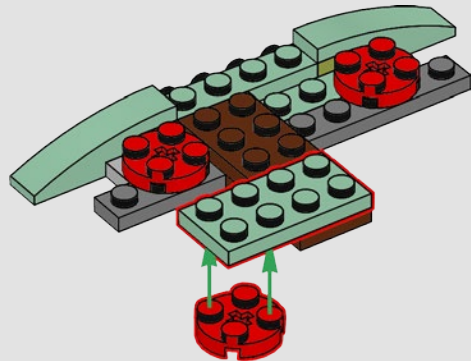

358

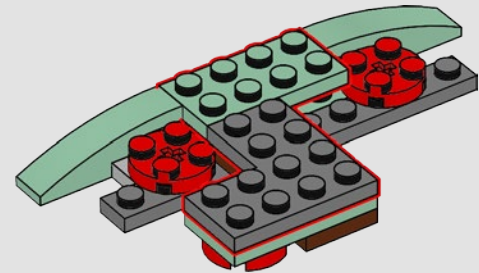

359

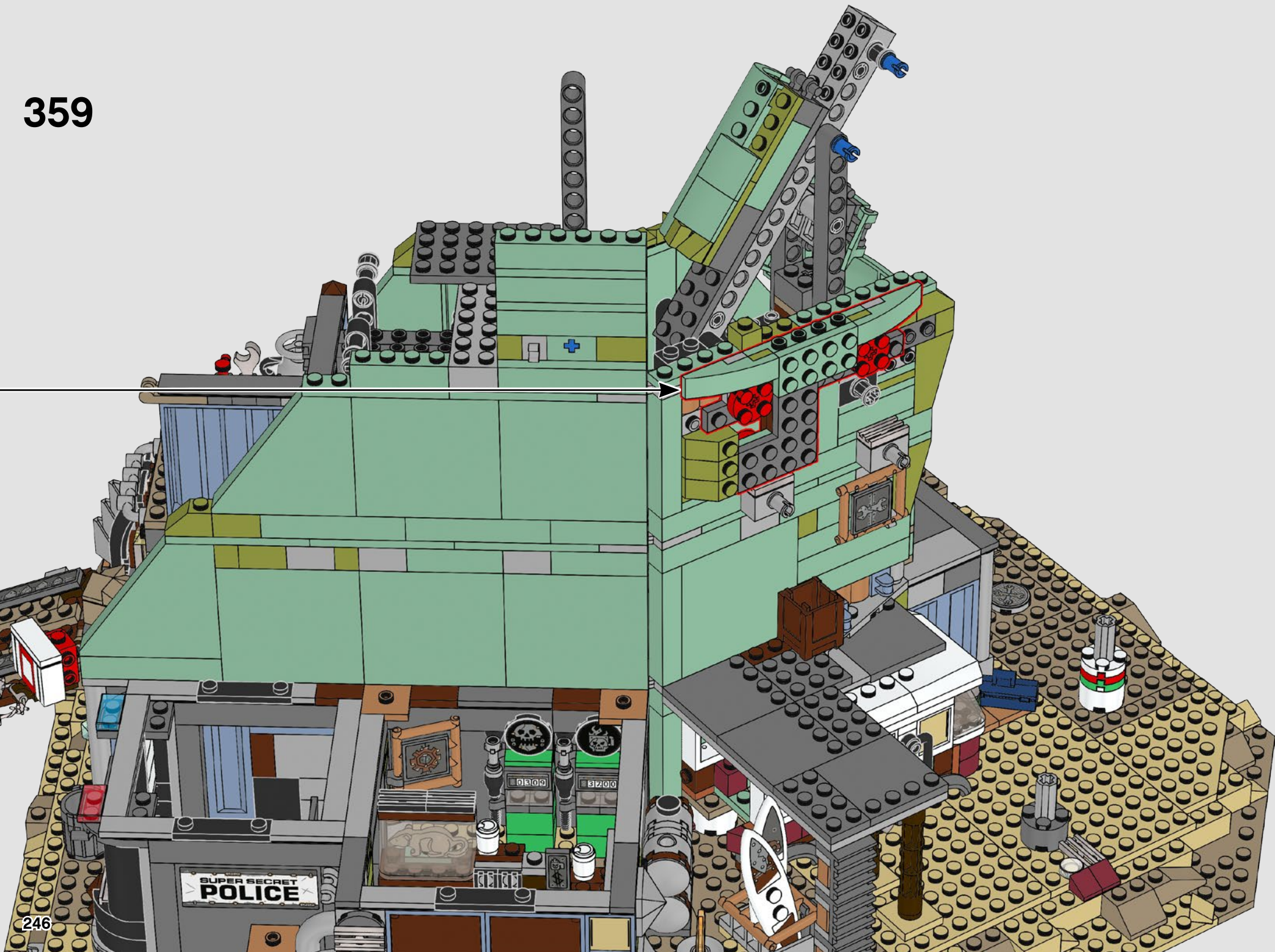

246

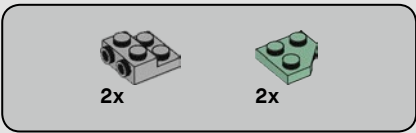

360

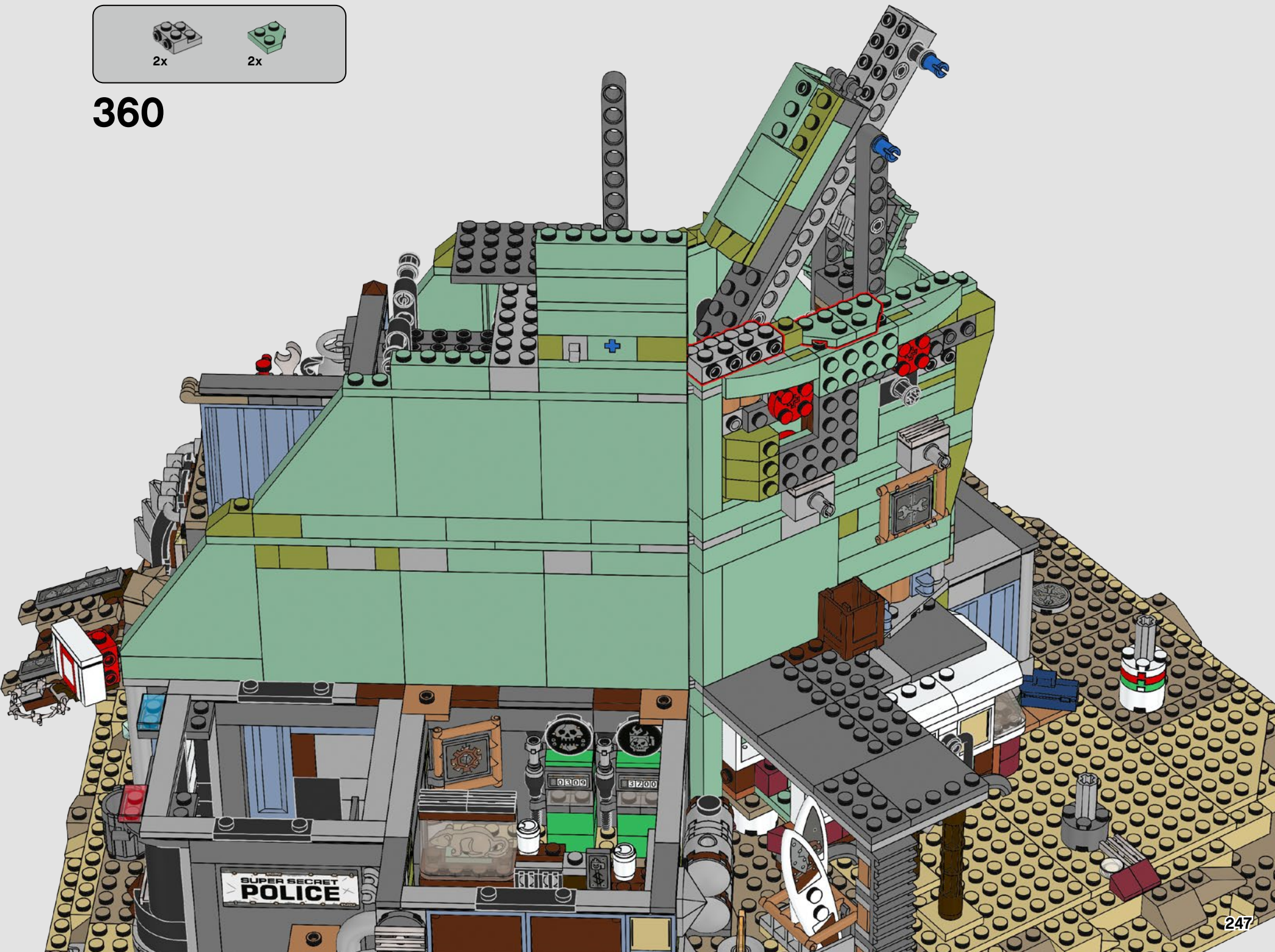

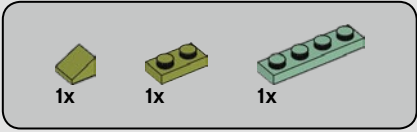

361

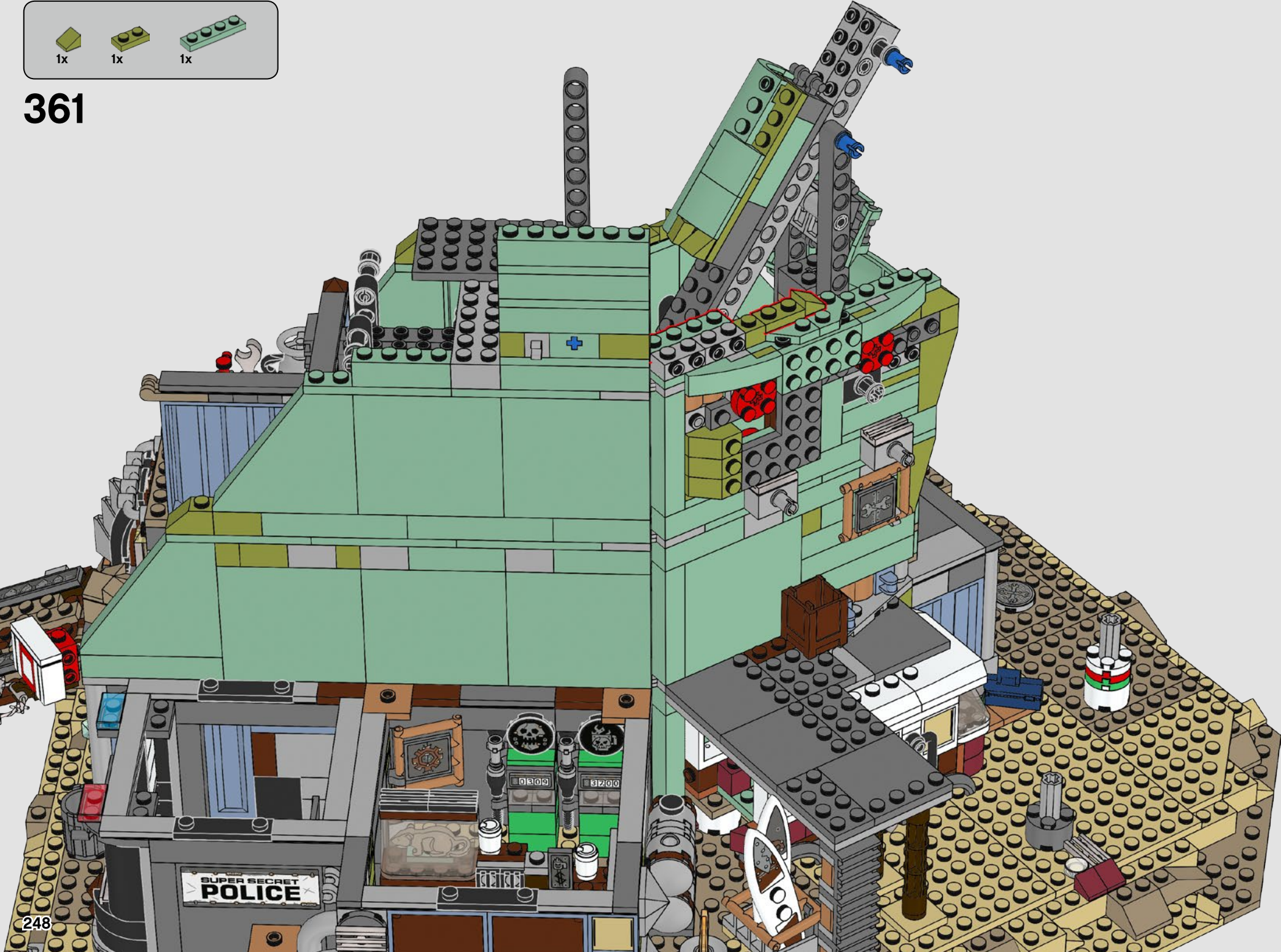



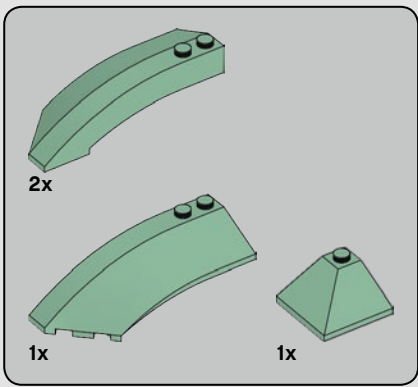

362

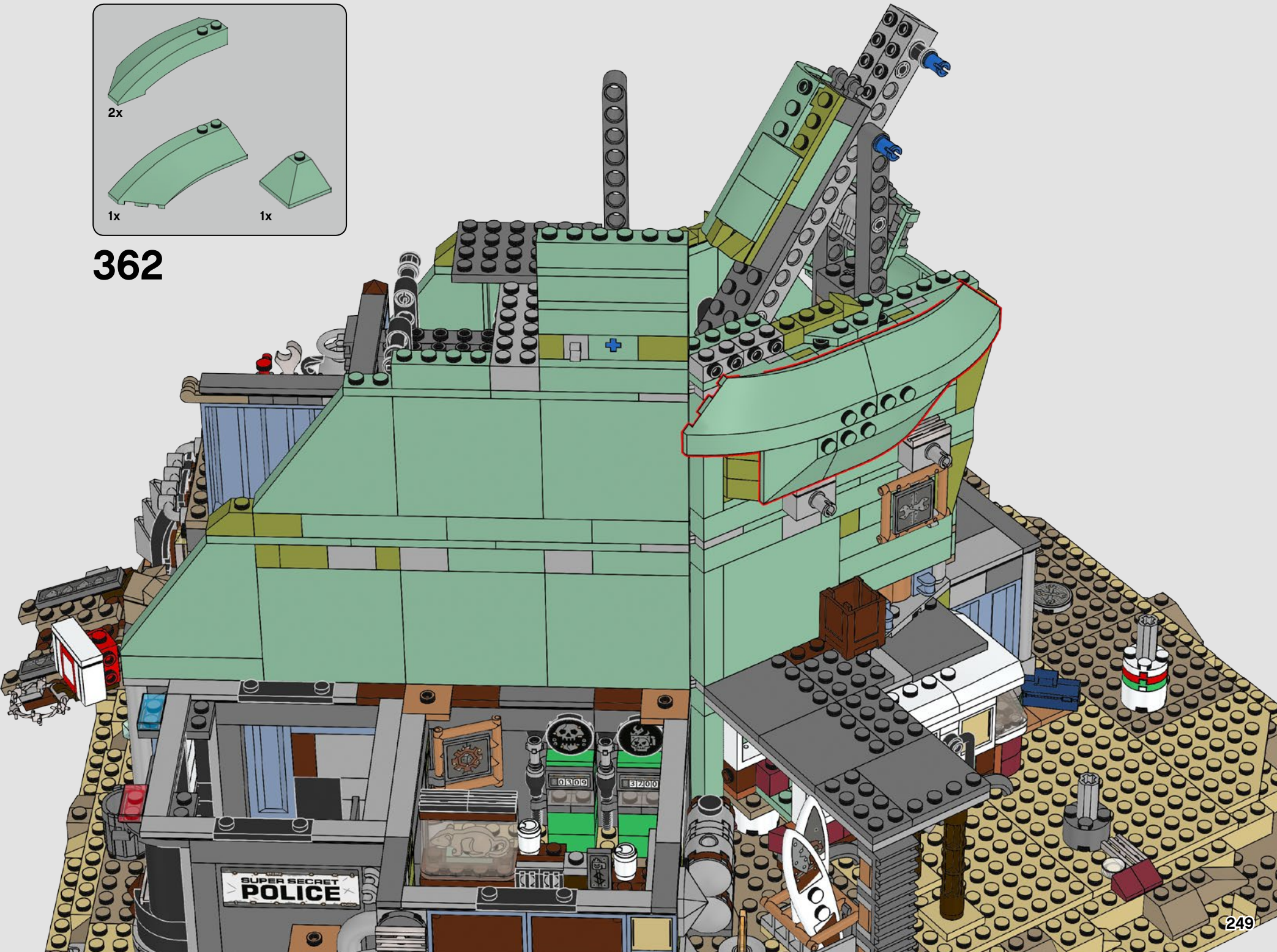

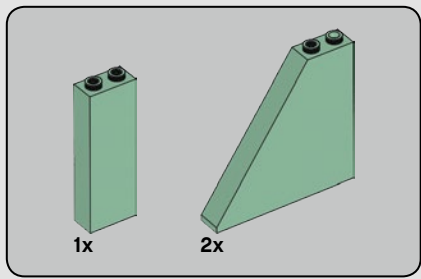

363

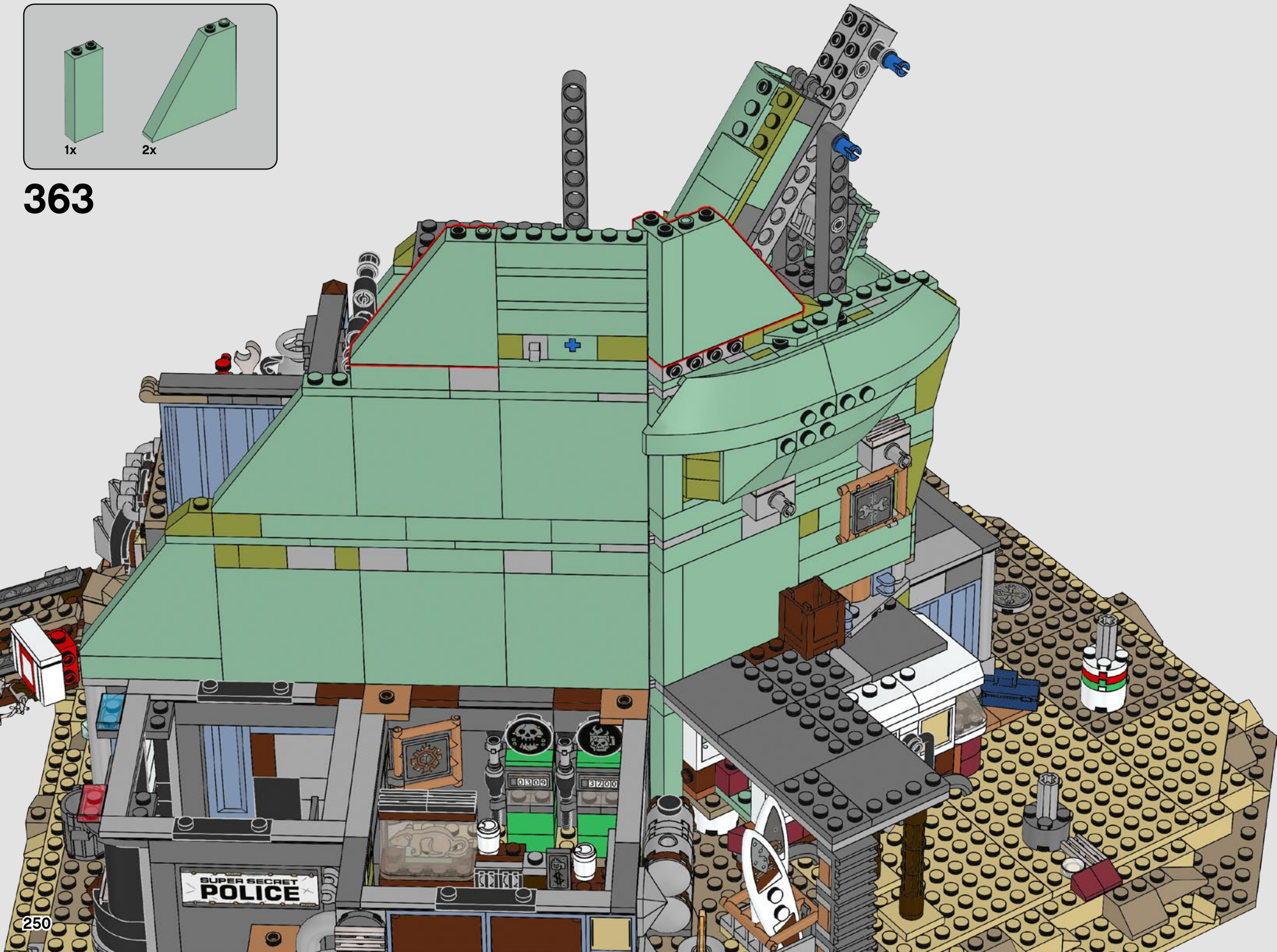

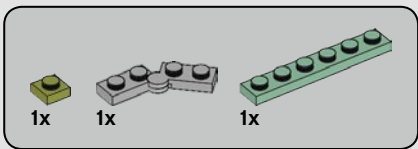

364

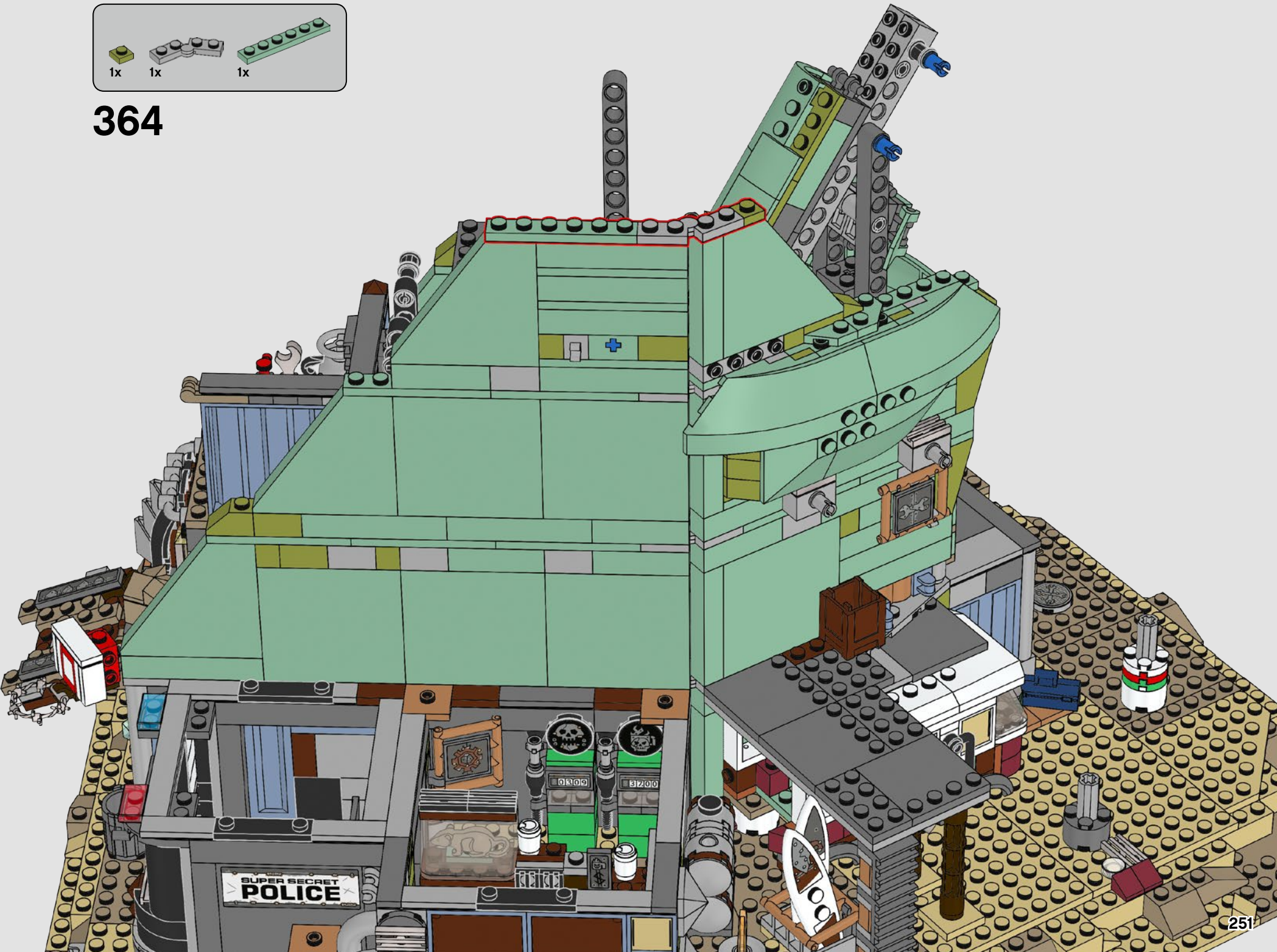

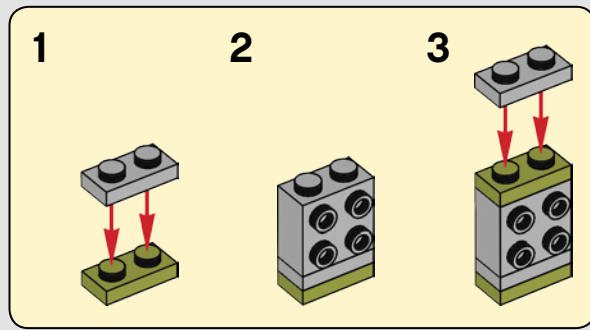
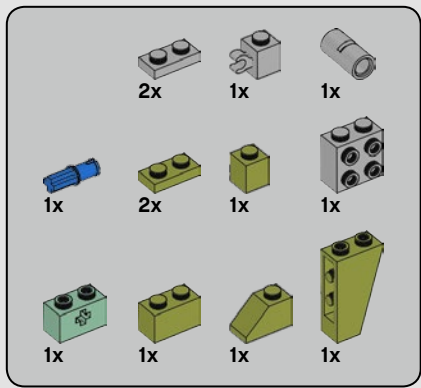

# 365

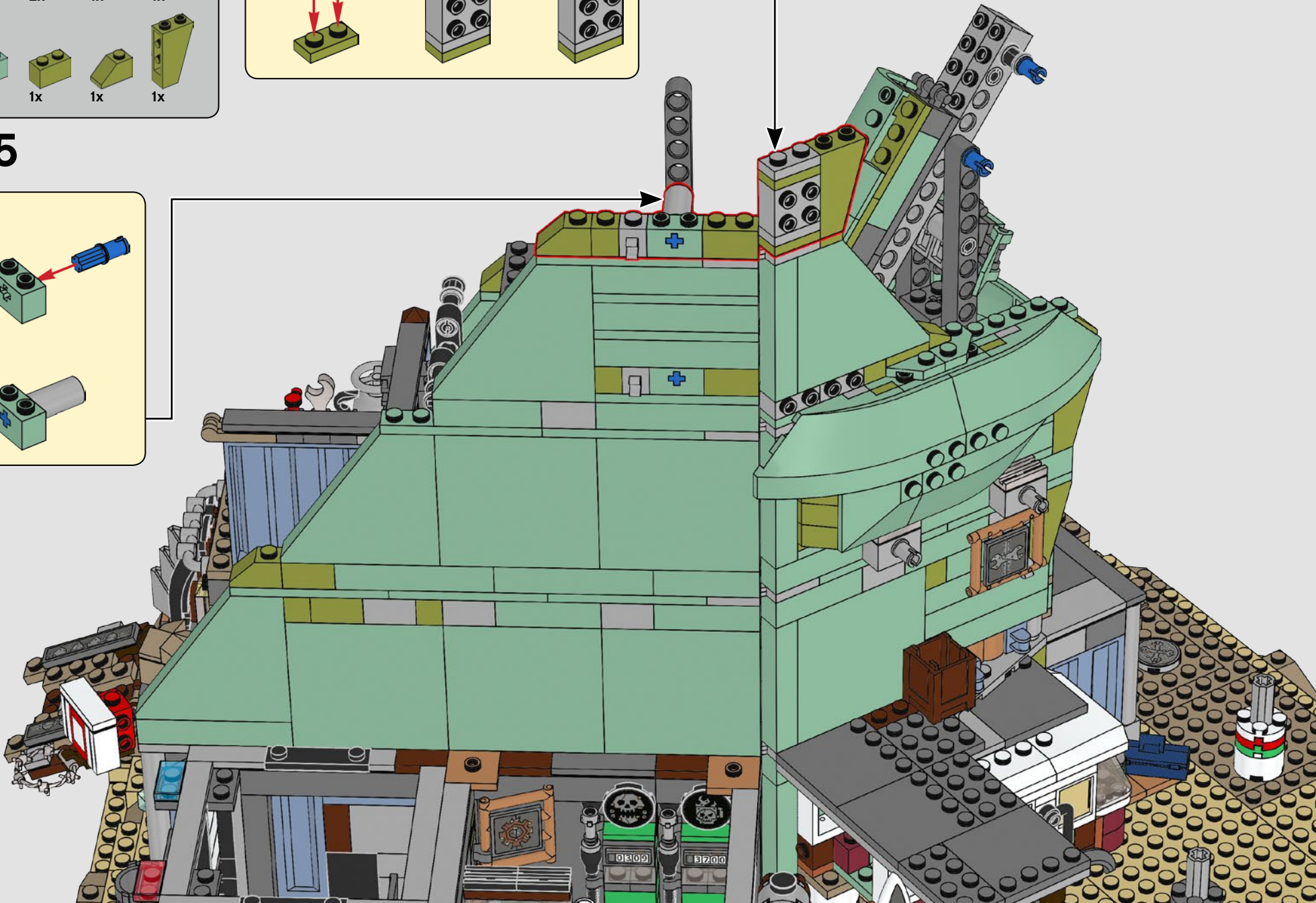
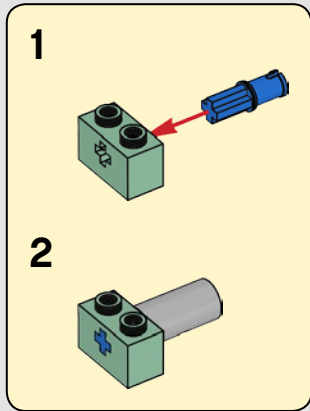

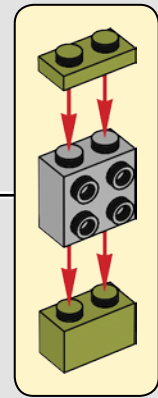
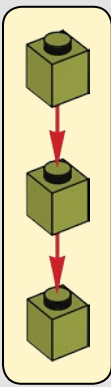
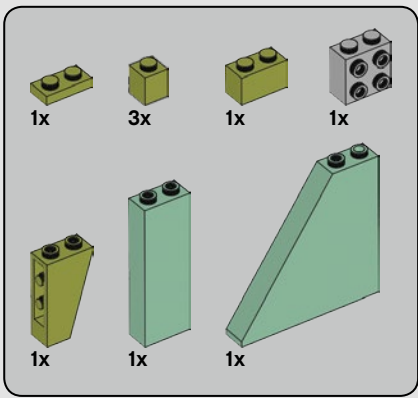

366

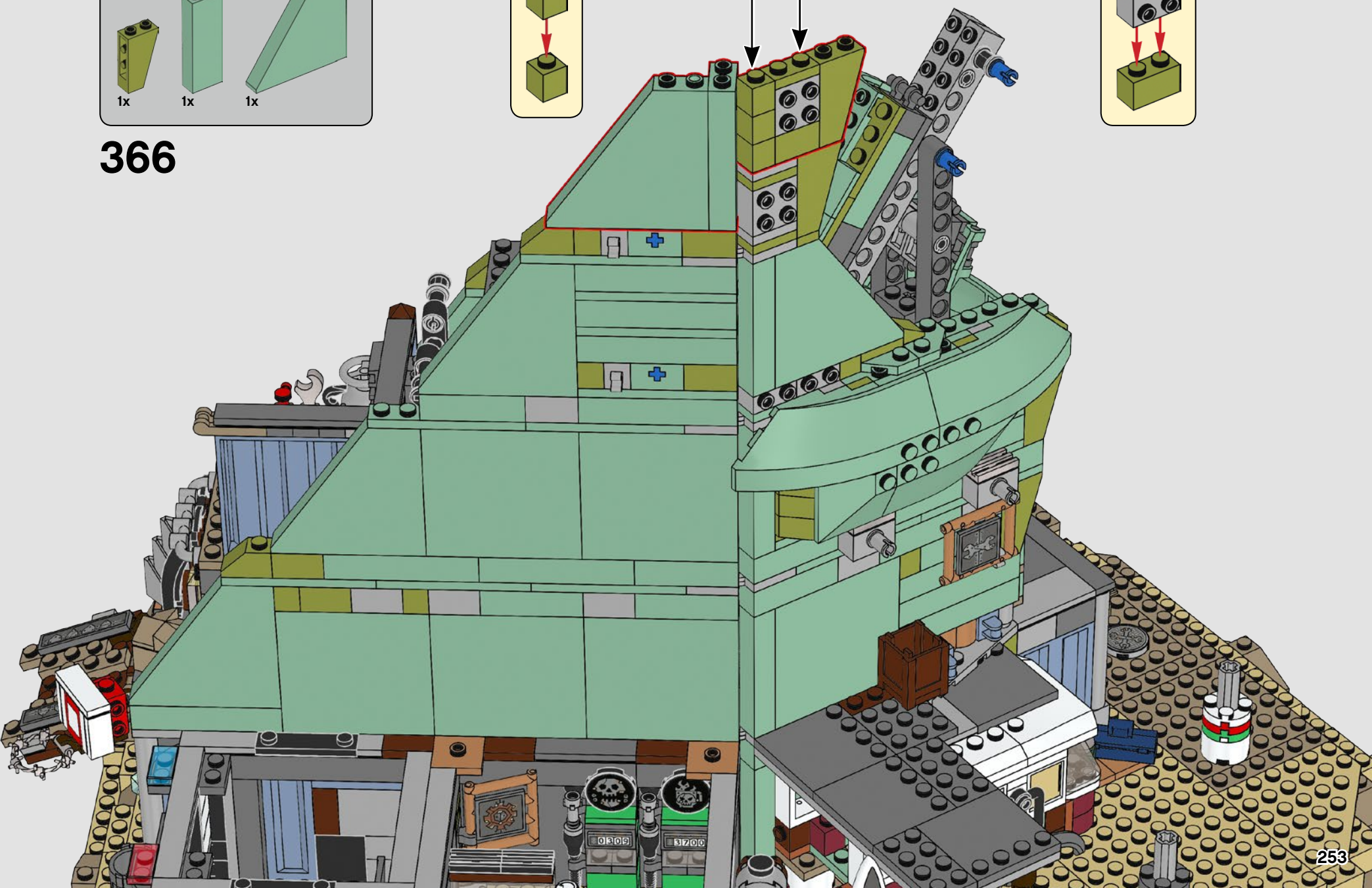

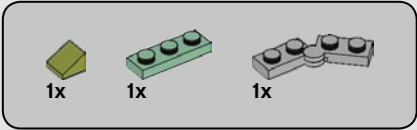

367

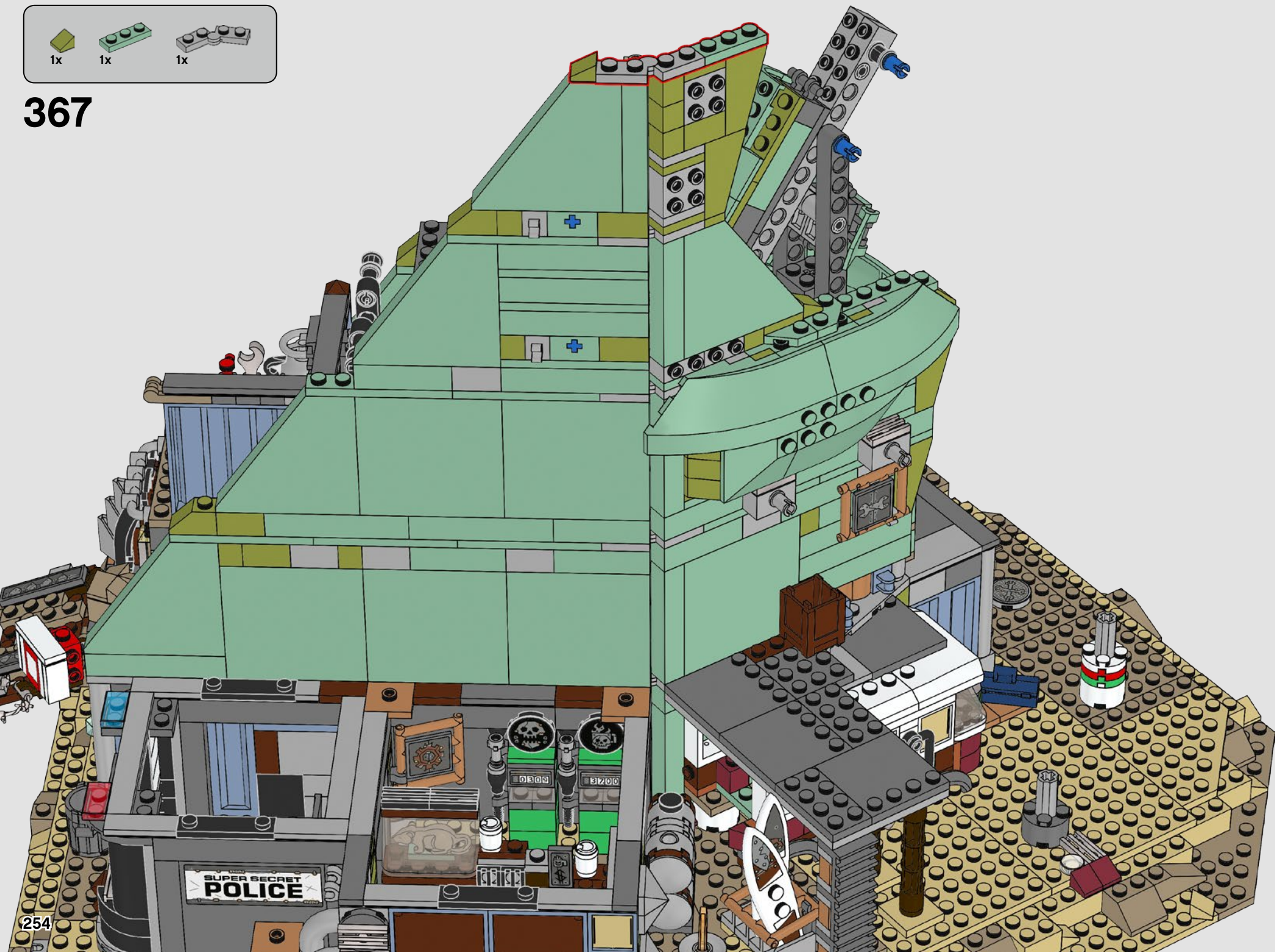

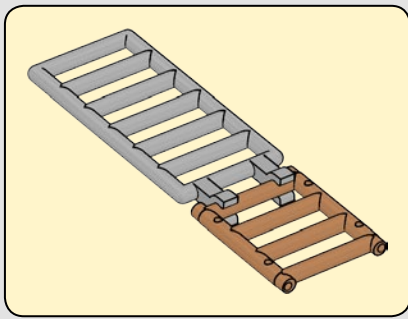
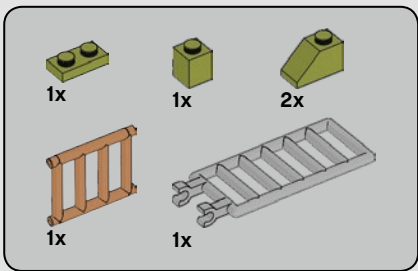

368

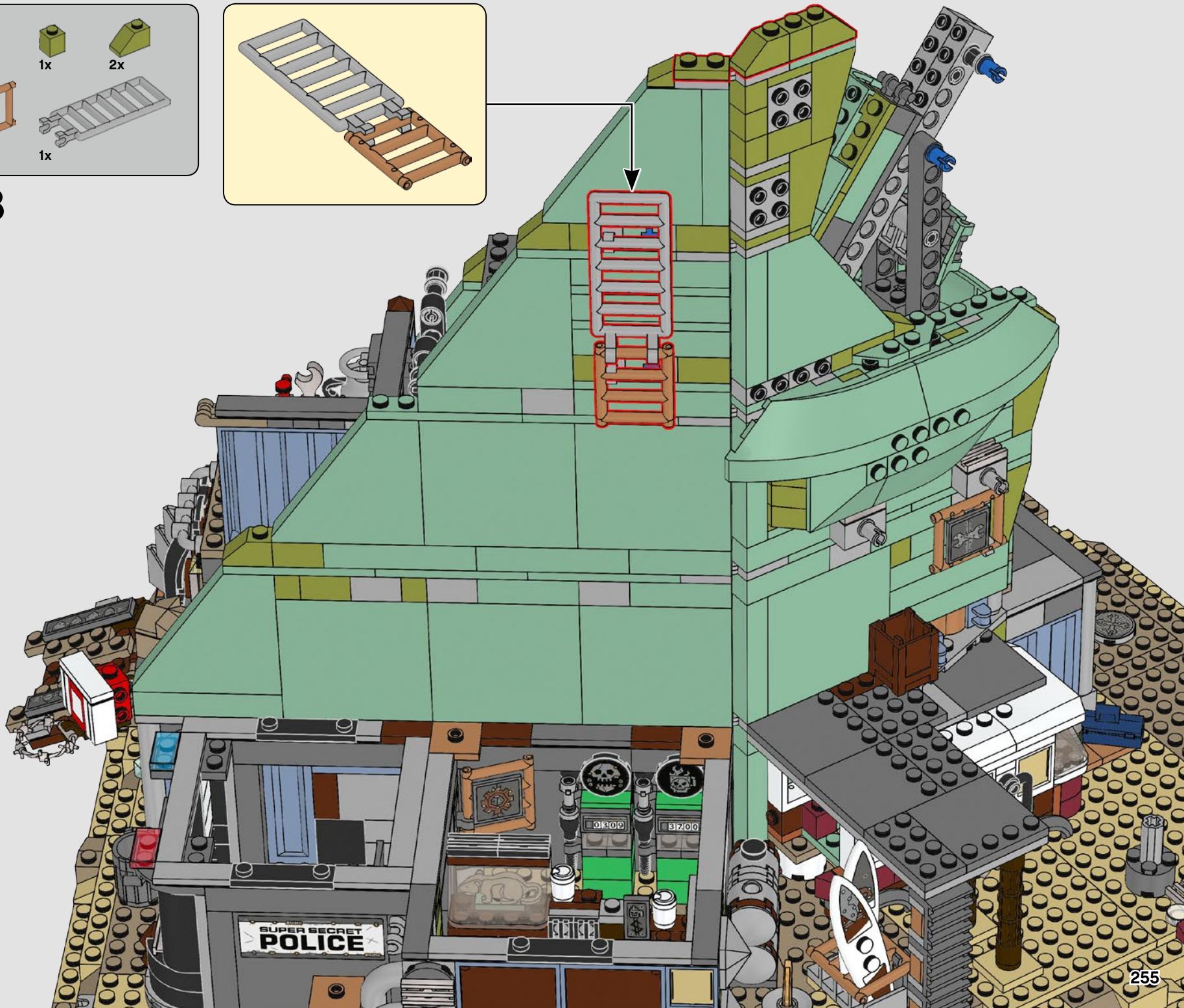

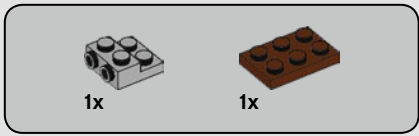

369

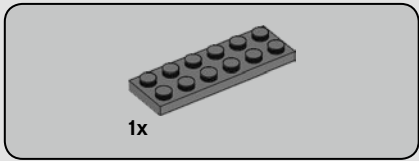
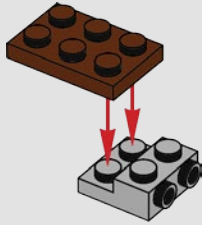

370

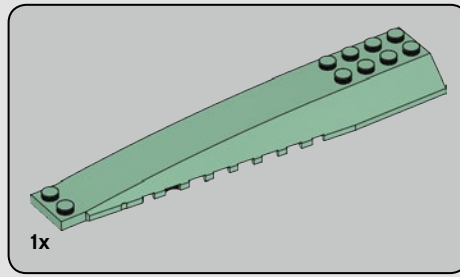
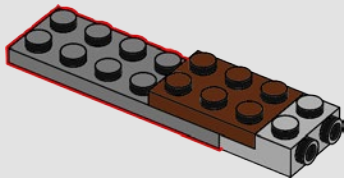

371

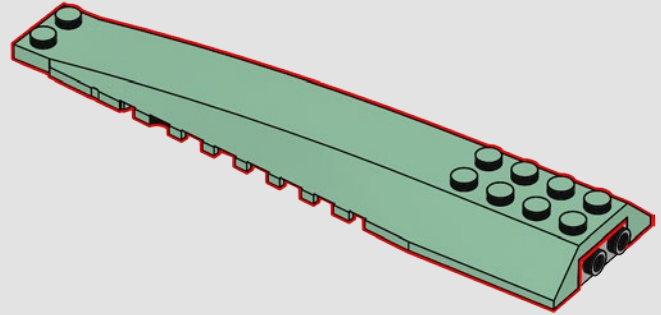

372

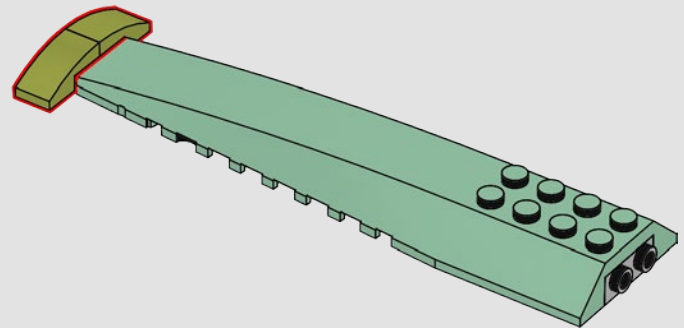



373

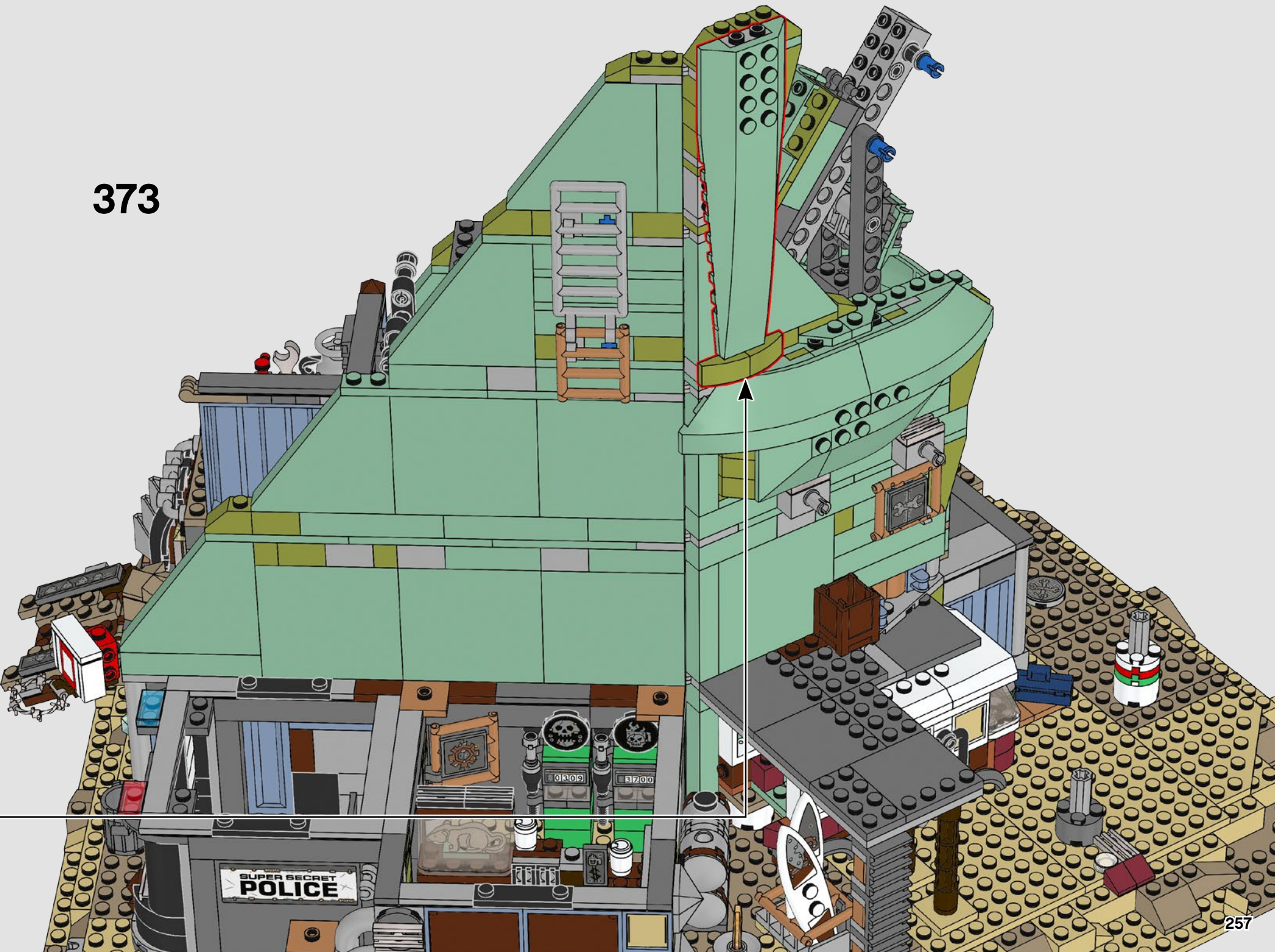



374

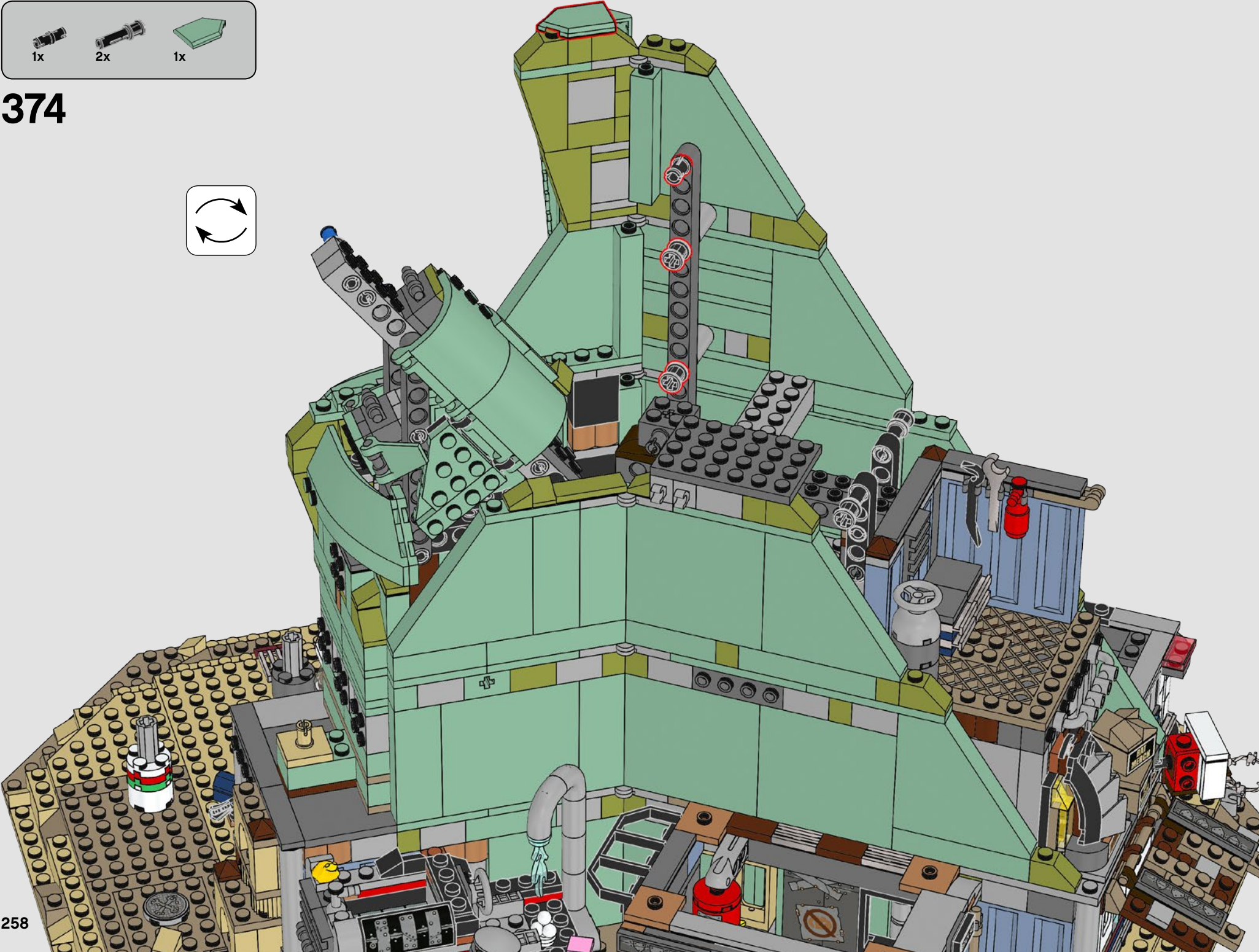
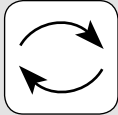

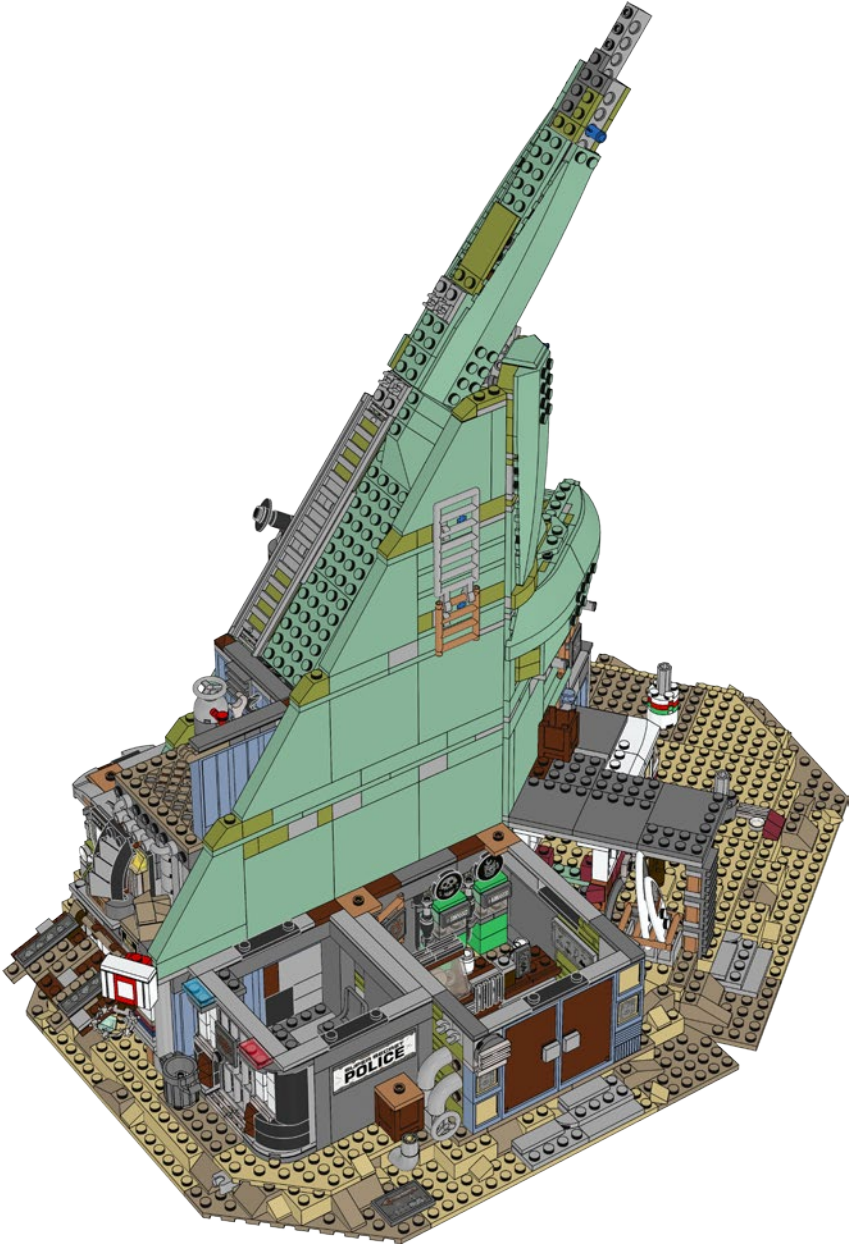
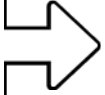
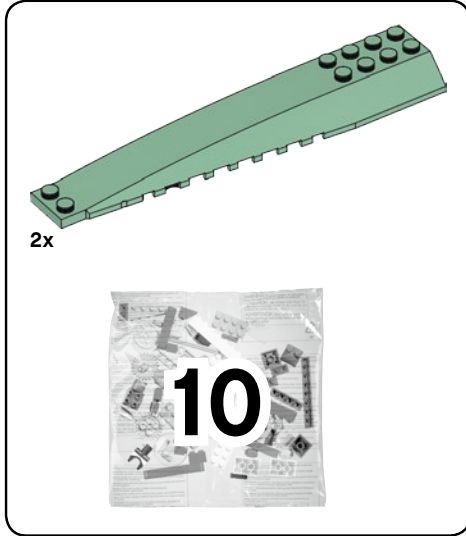

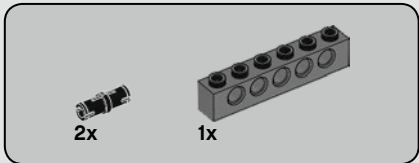
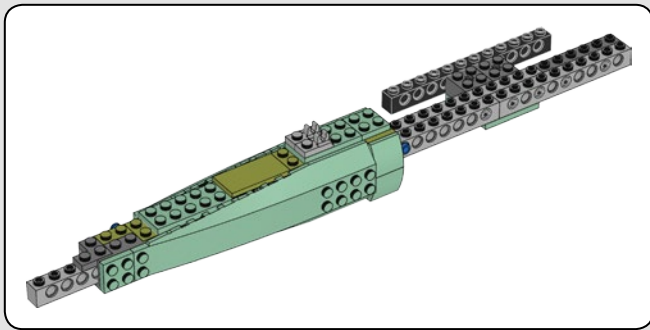

**375**

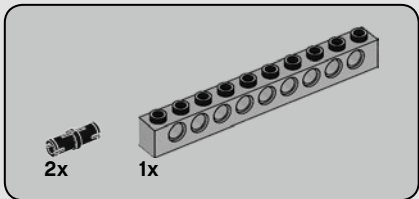
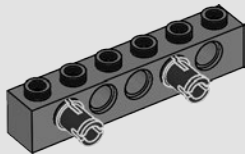

**376**

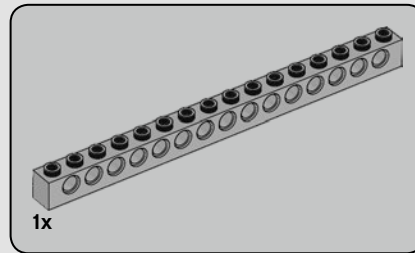
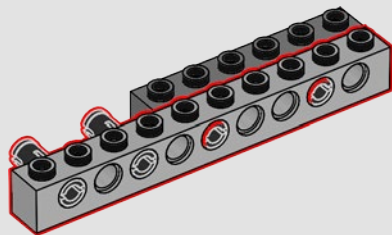

**377**

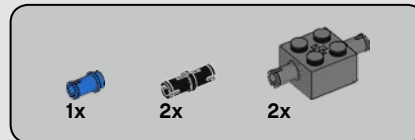
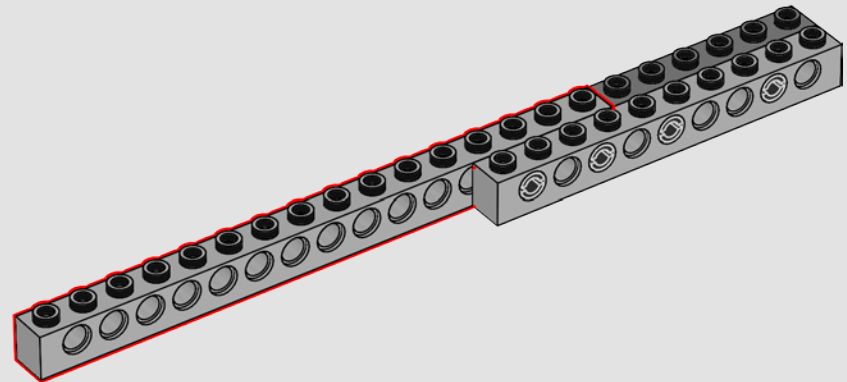

**378**

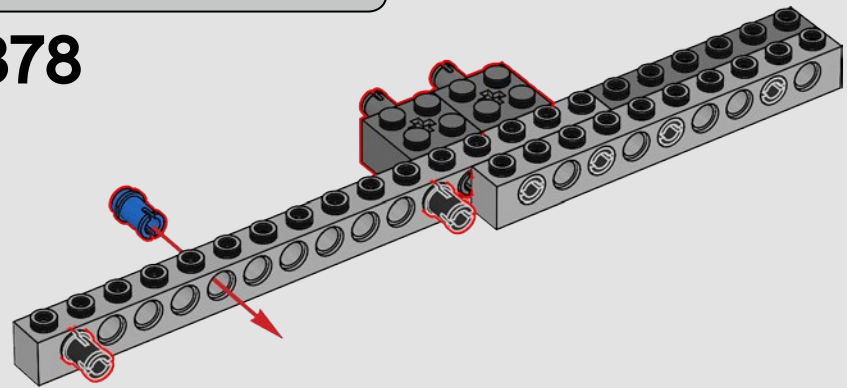

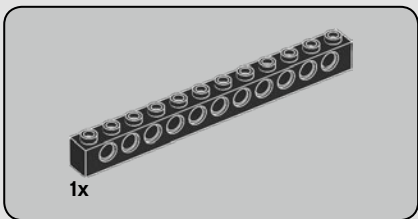

**379**

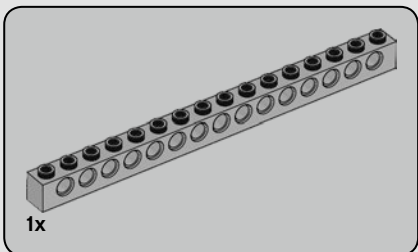
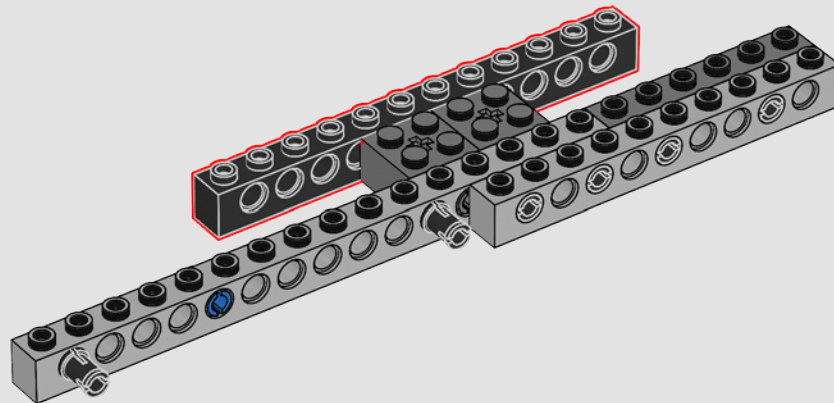

**380**

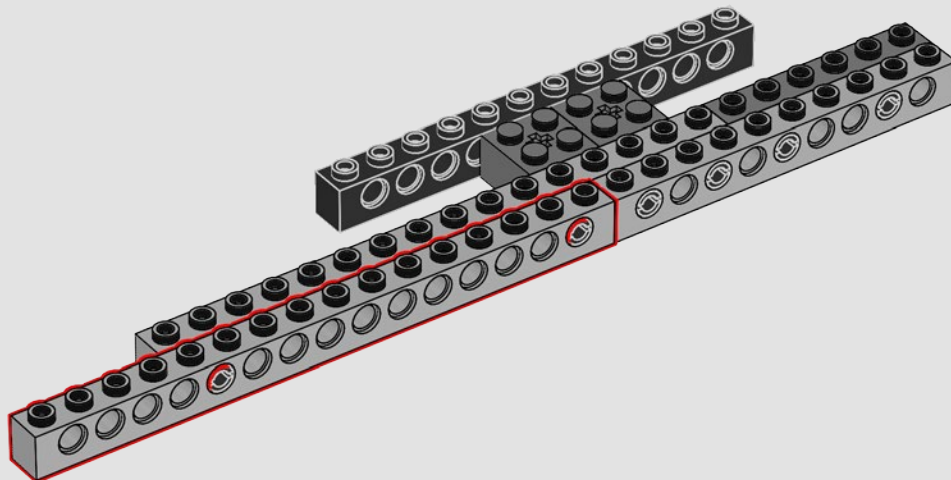

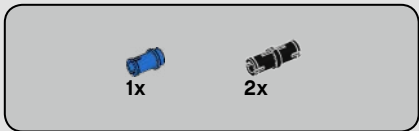

381

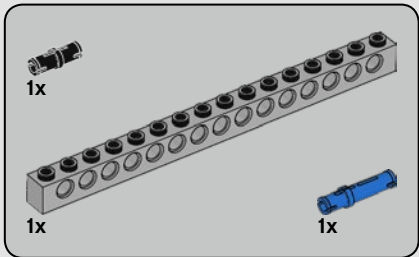
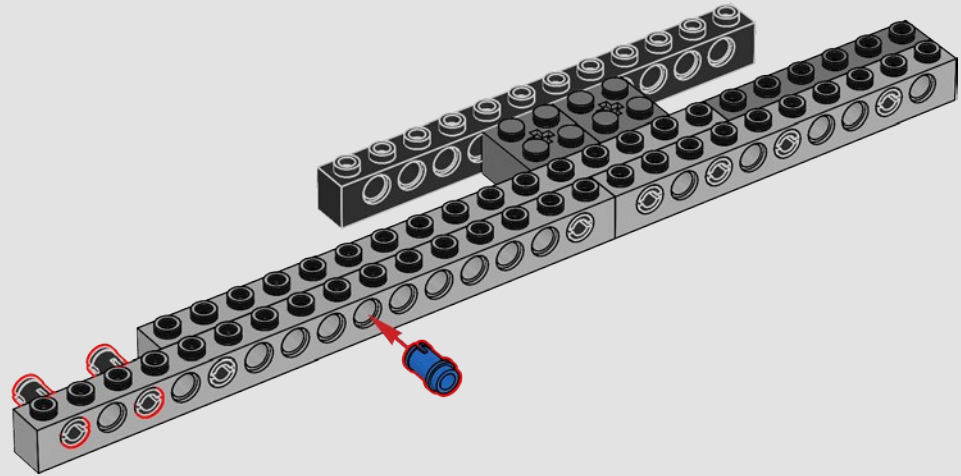

382

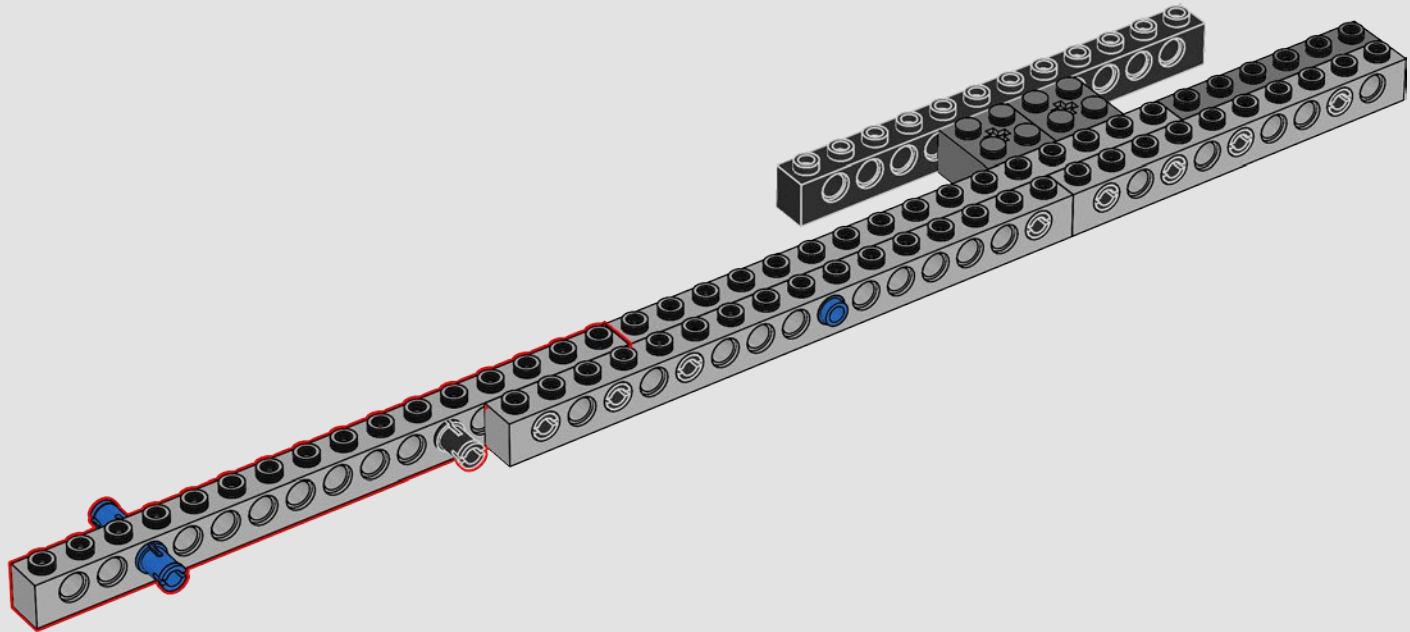

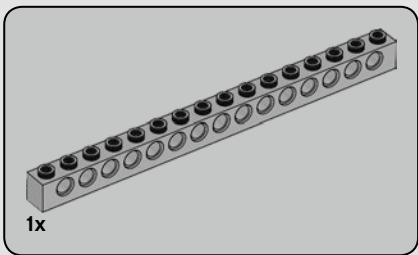

**383**

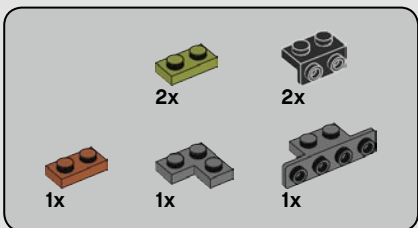
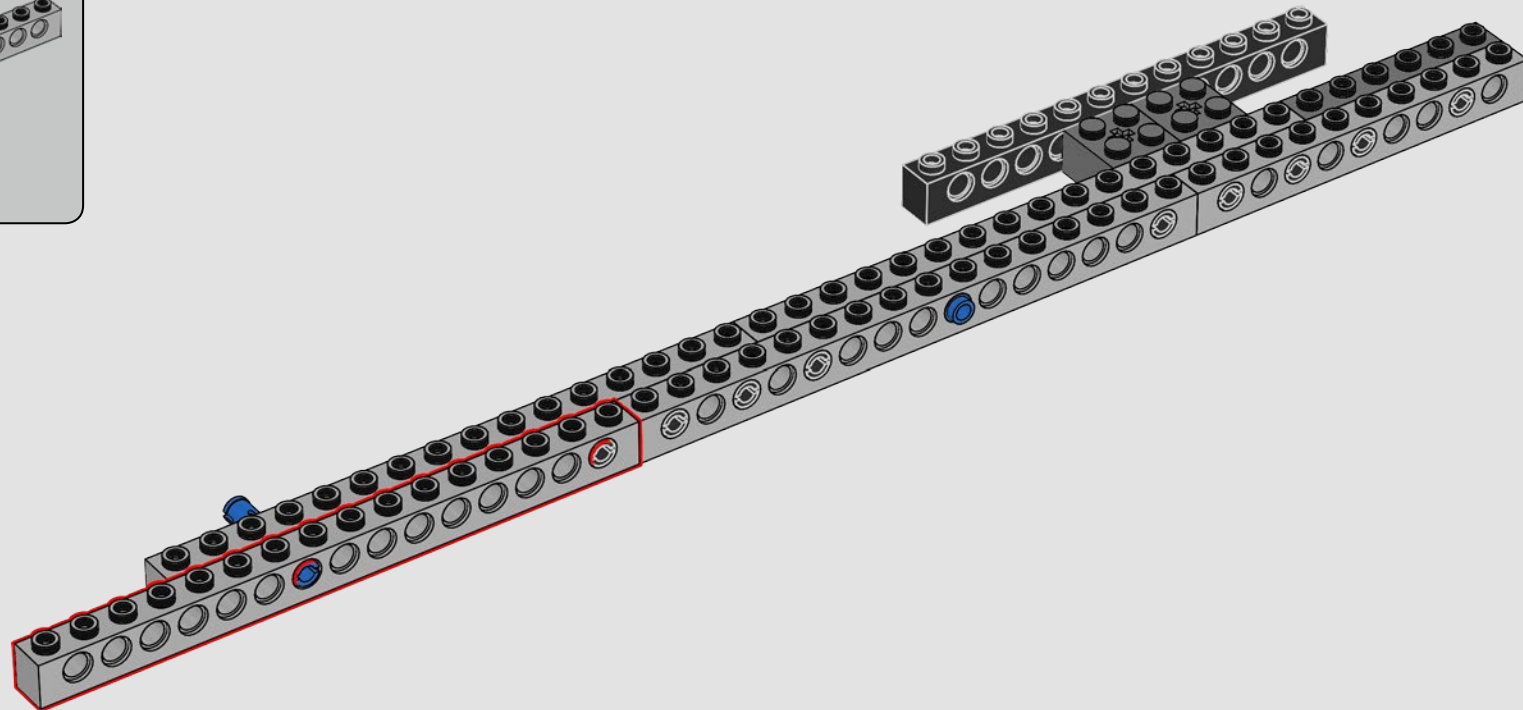

**384**

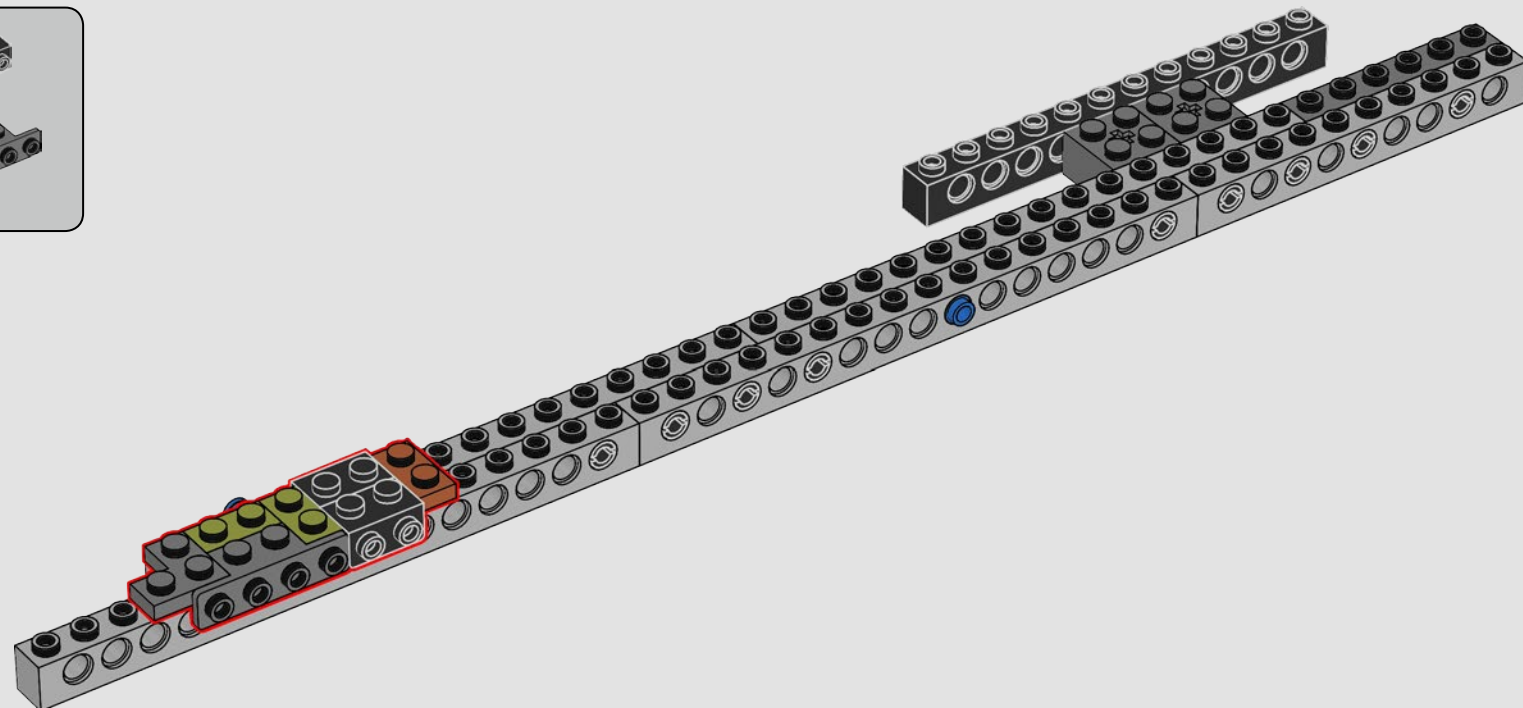

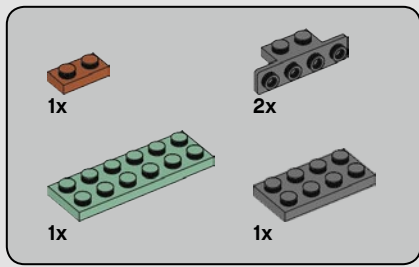

385

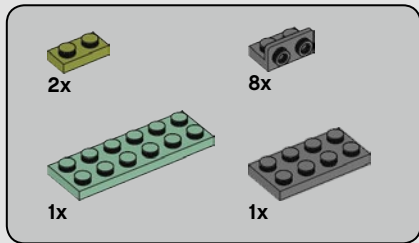
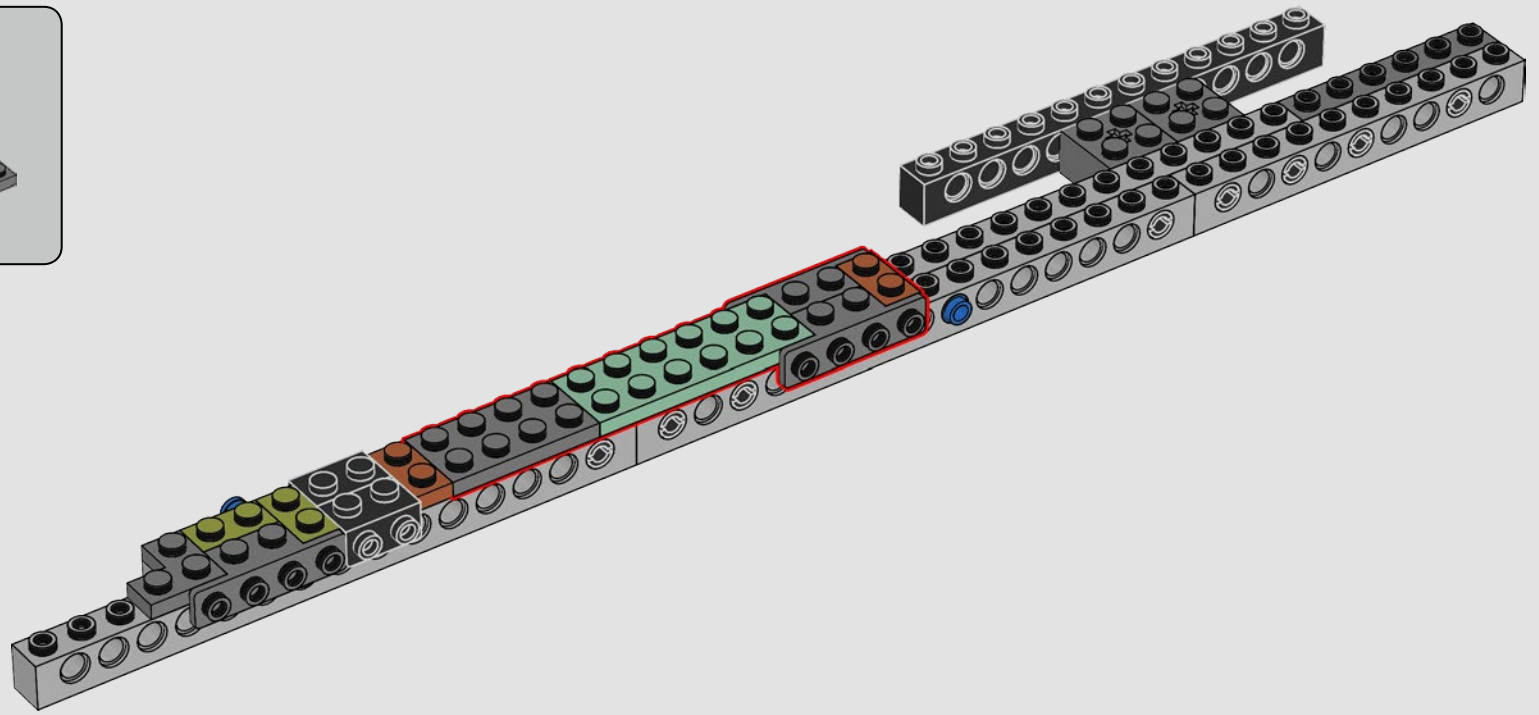

386

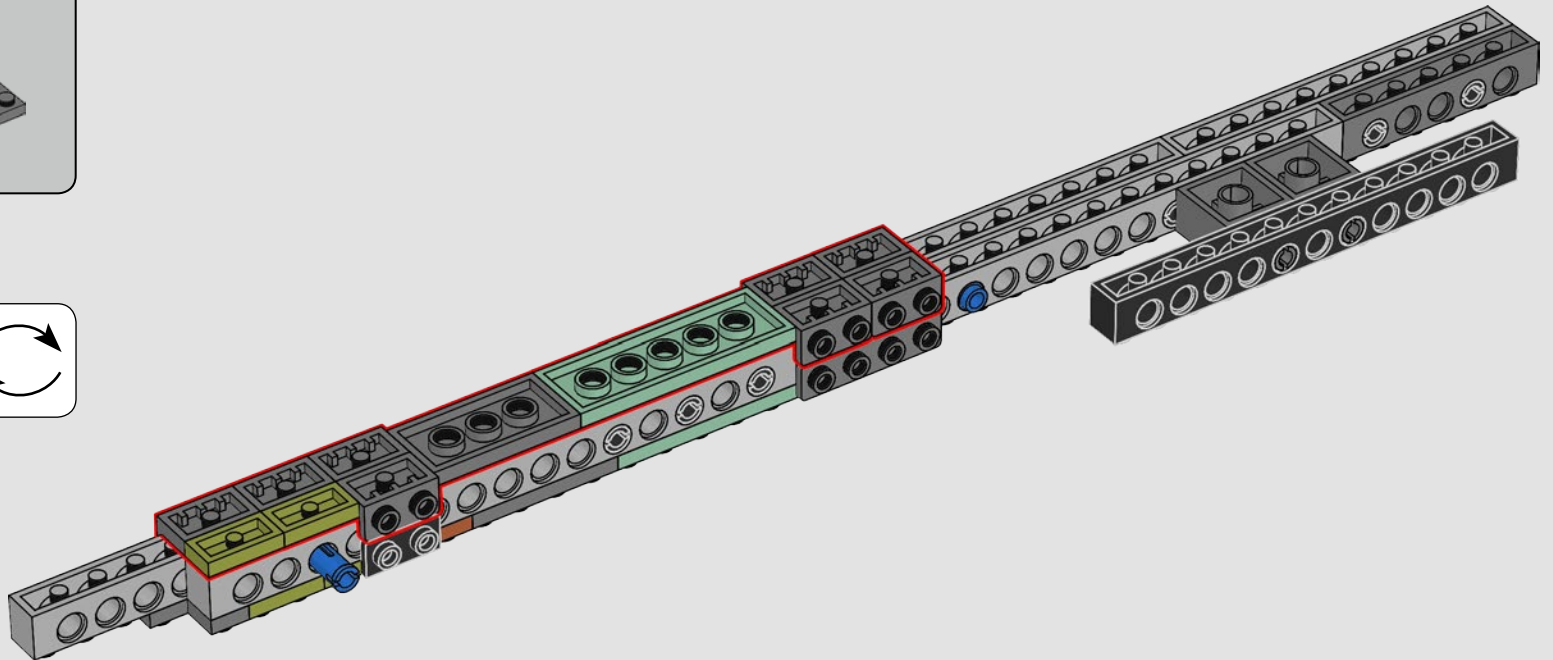
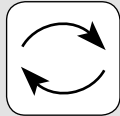



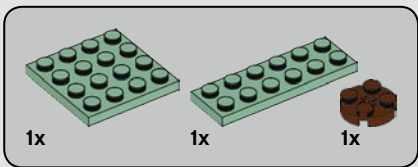

387

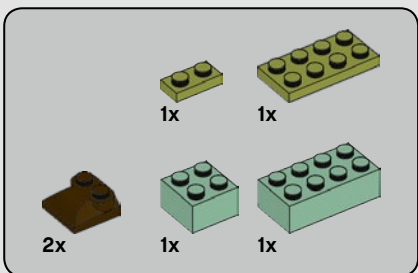
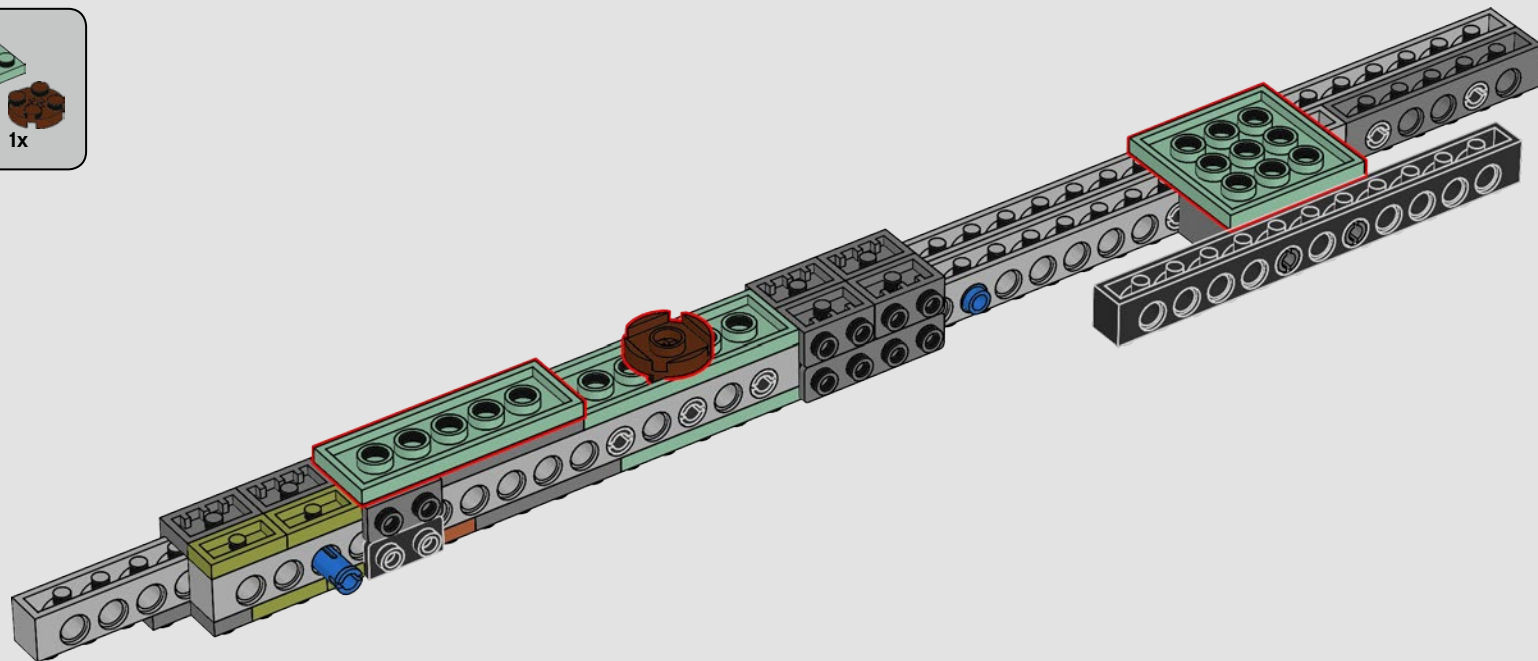

388

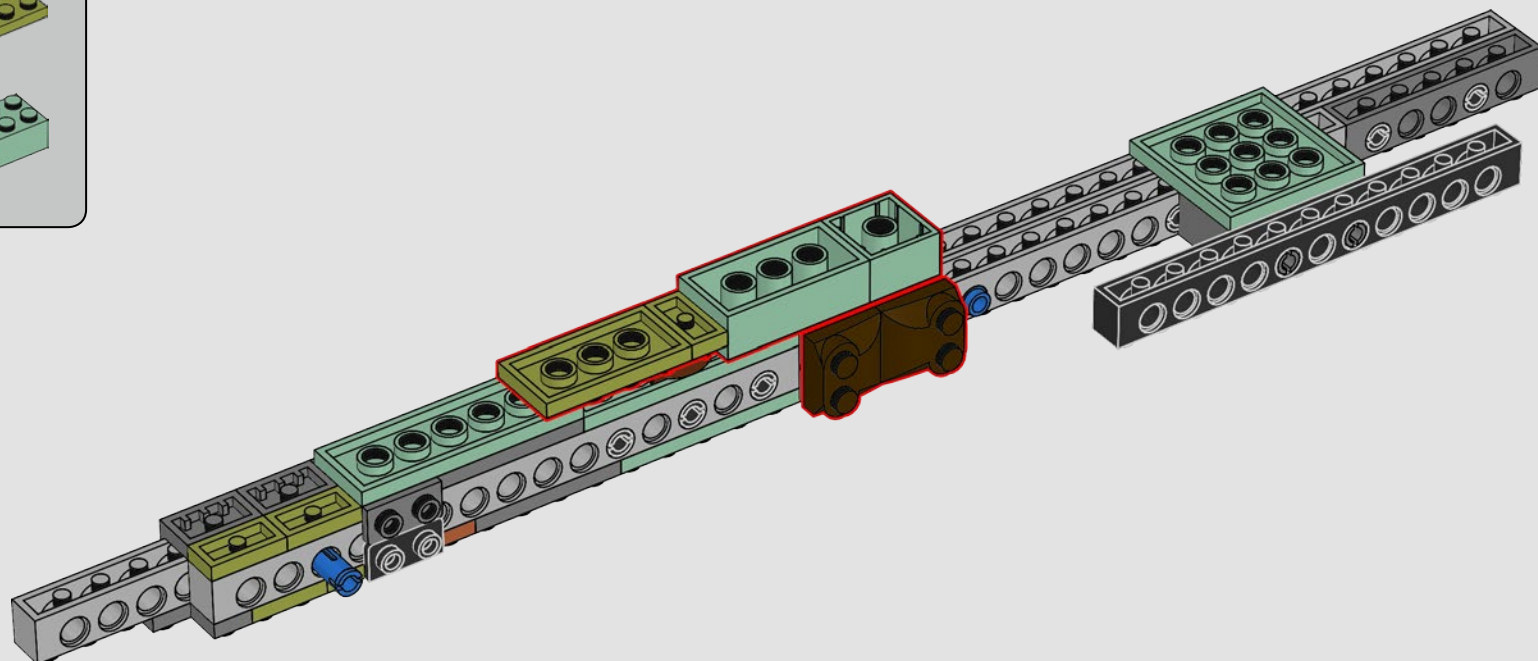

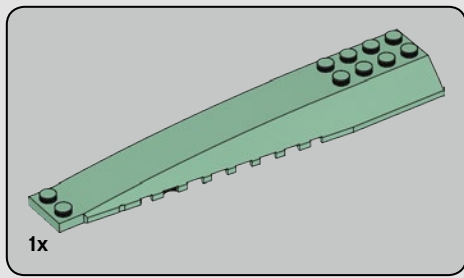

389

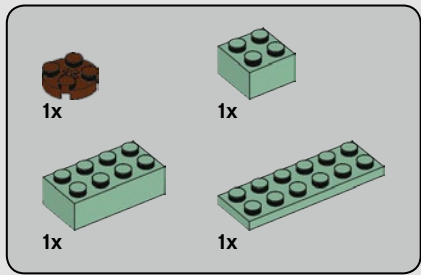
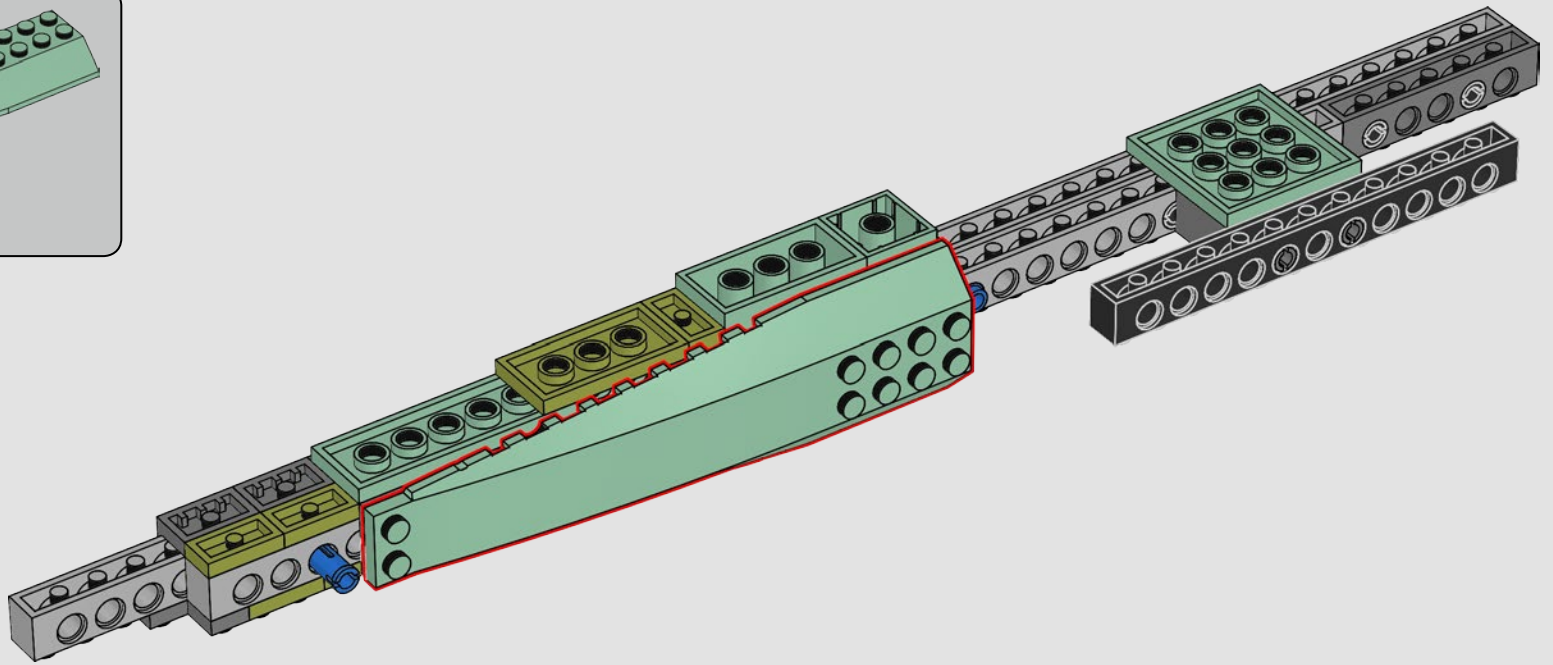

390

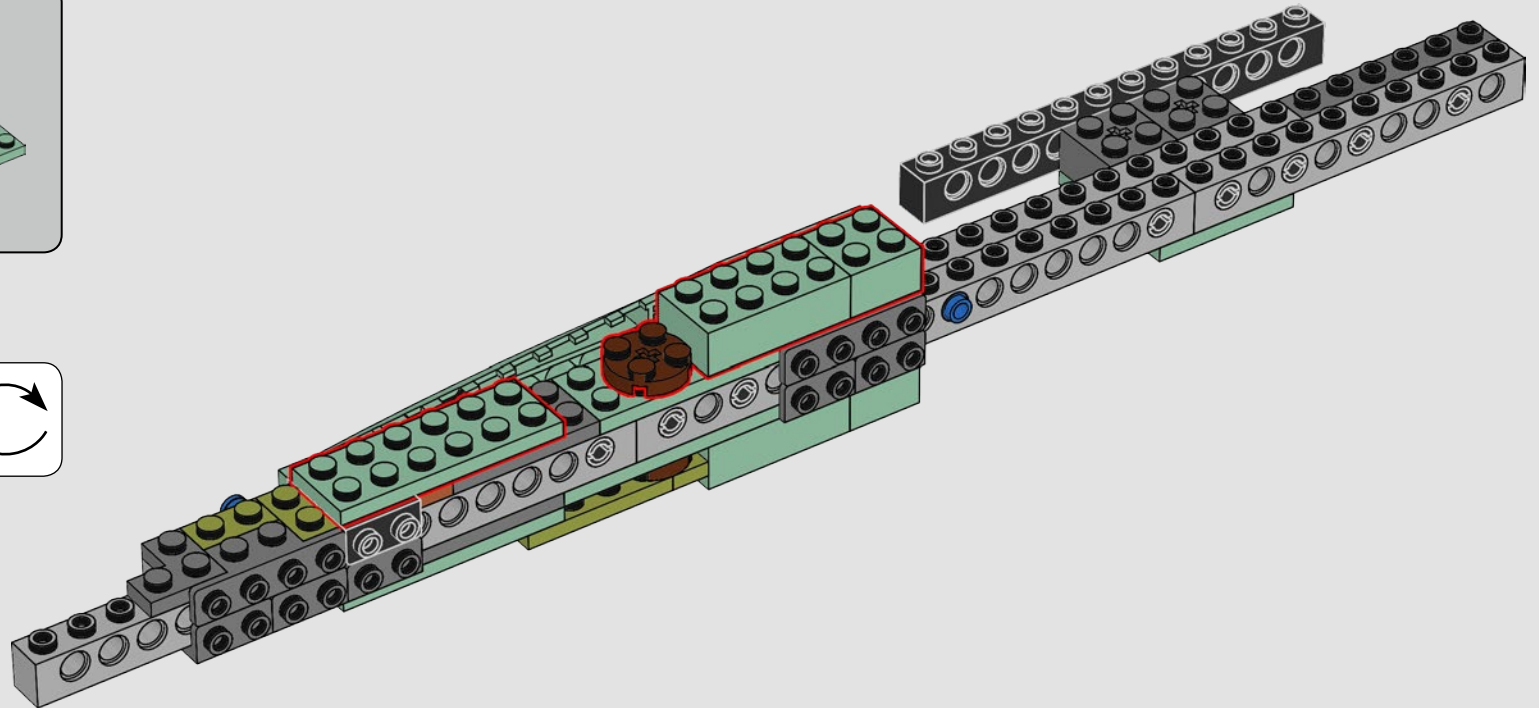
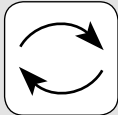

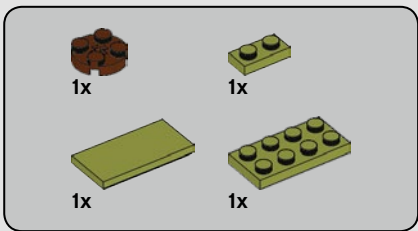

391

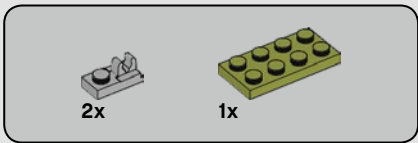
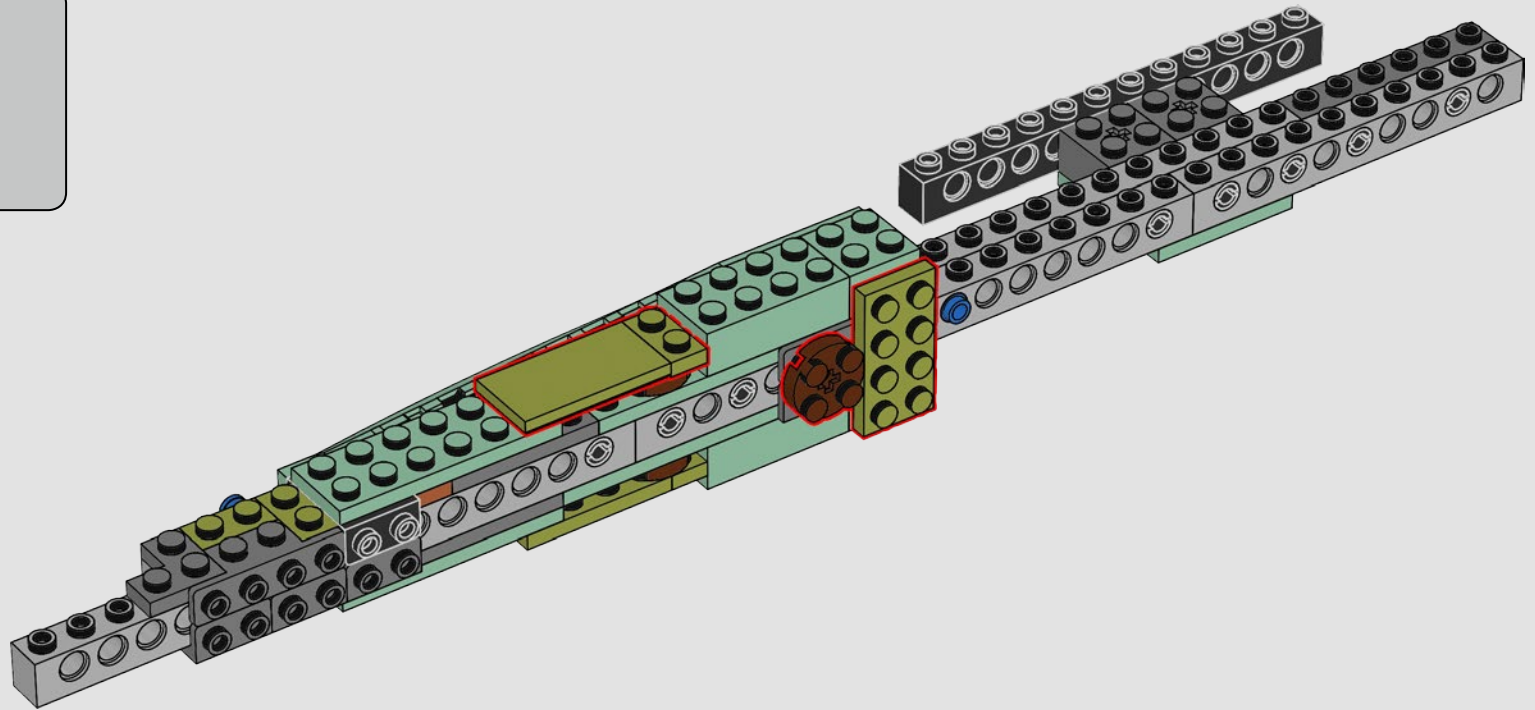

392

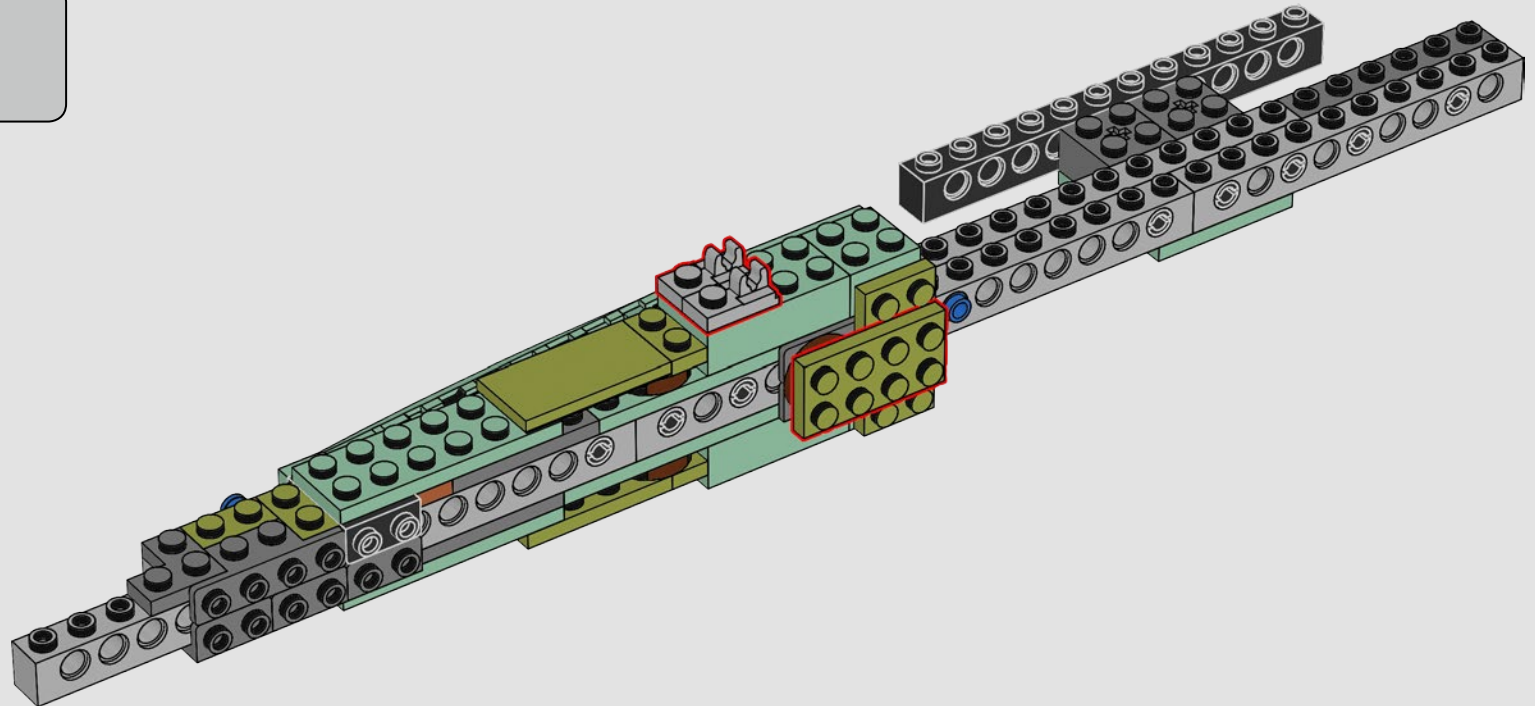

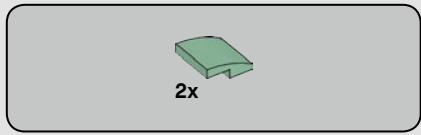

393

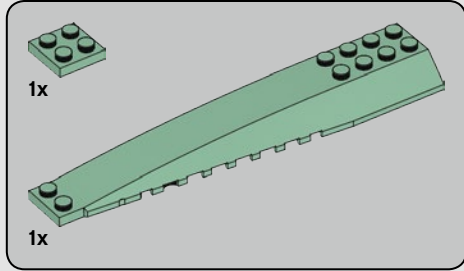
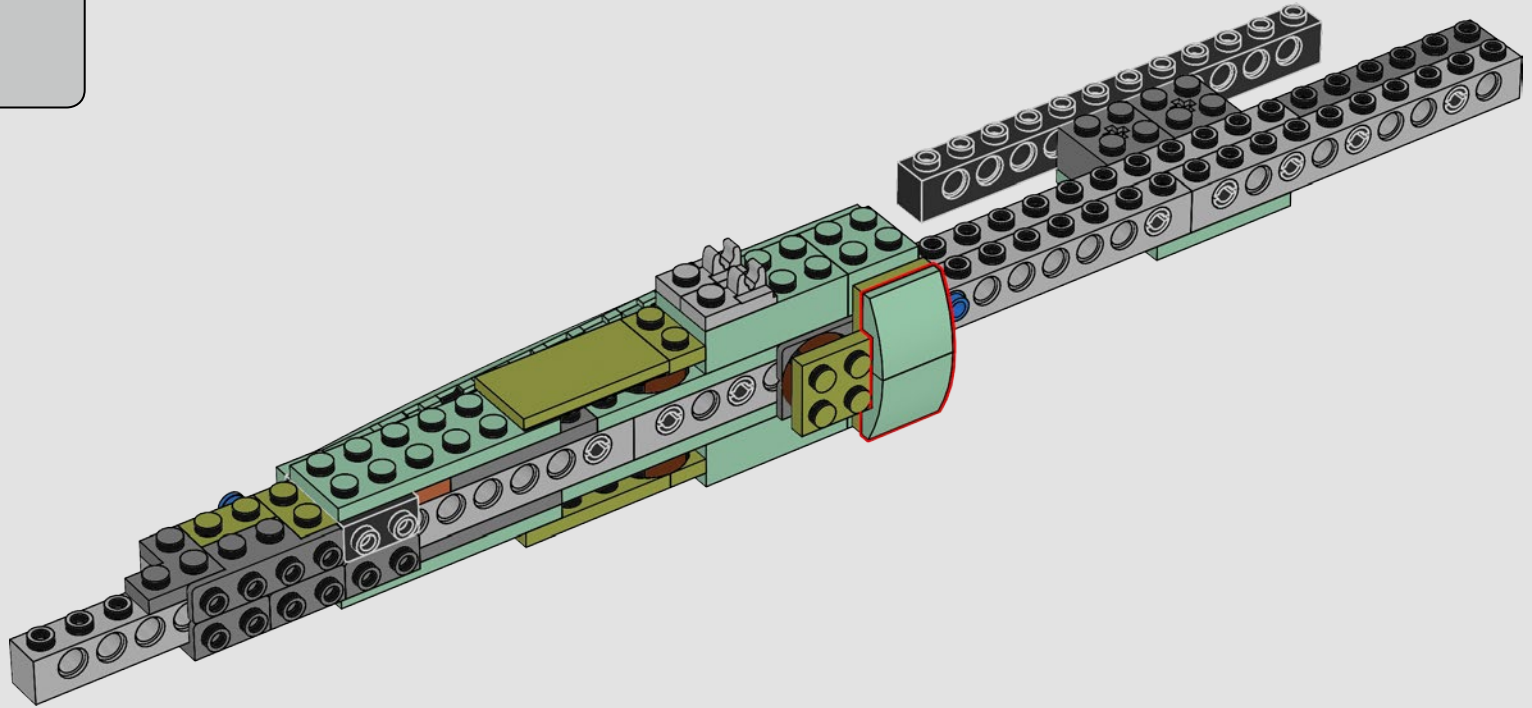

394

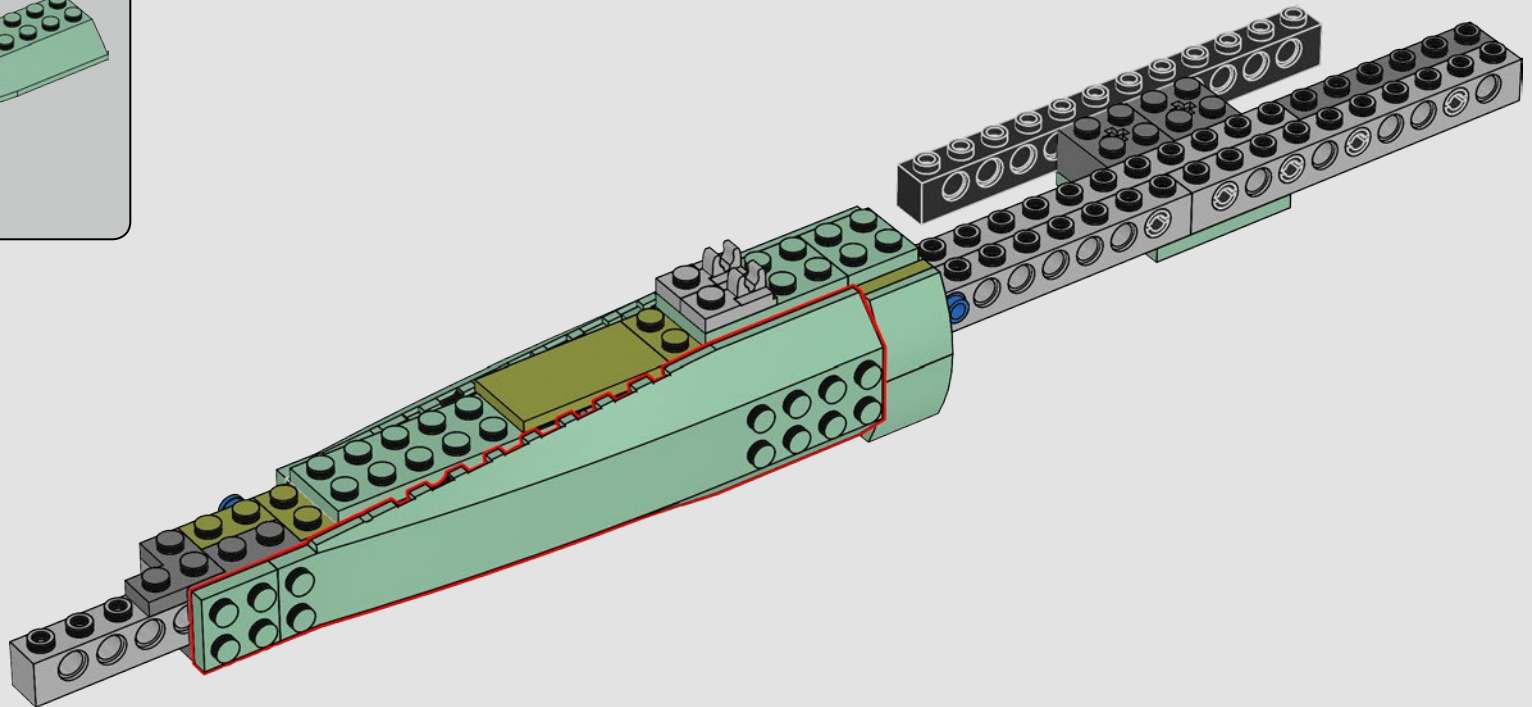

395

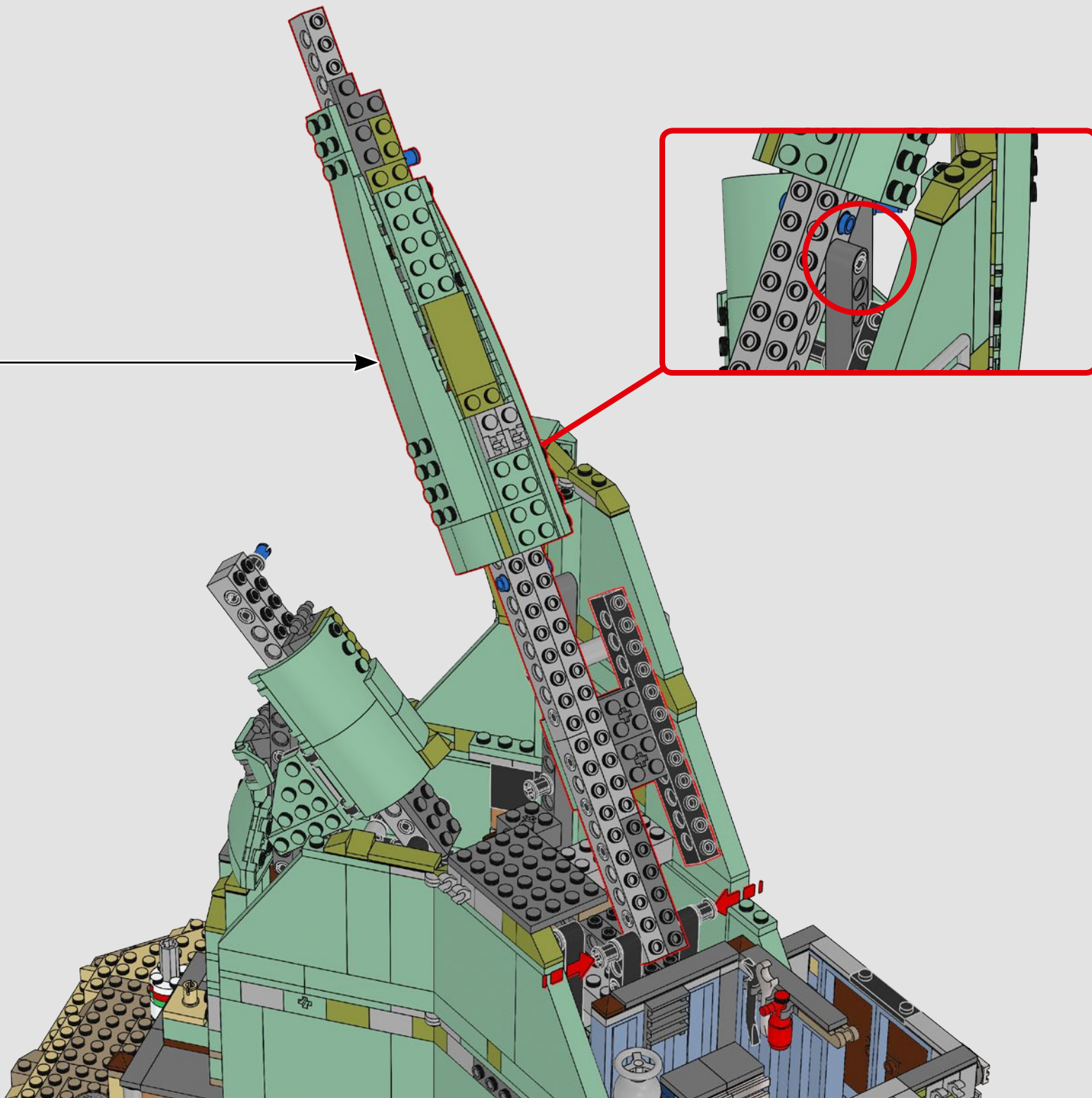

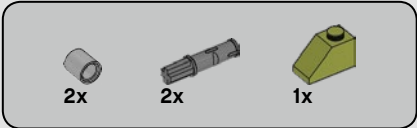

396

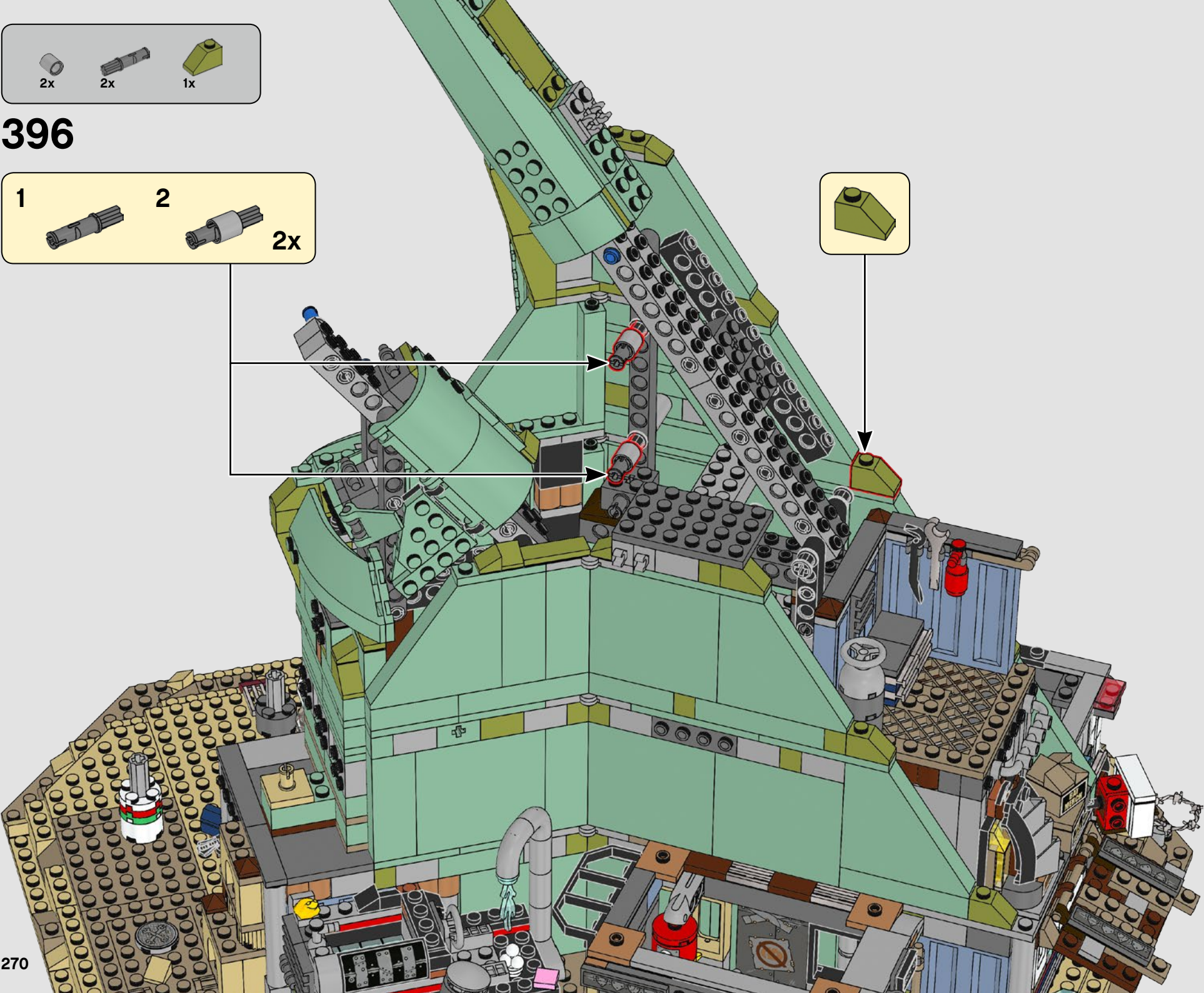
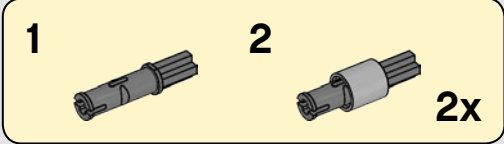

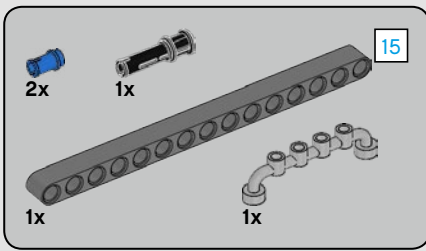

397

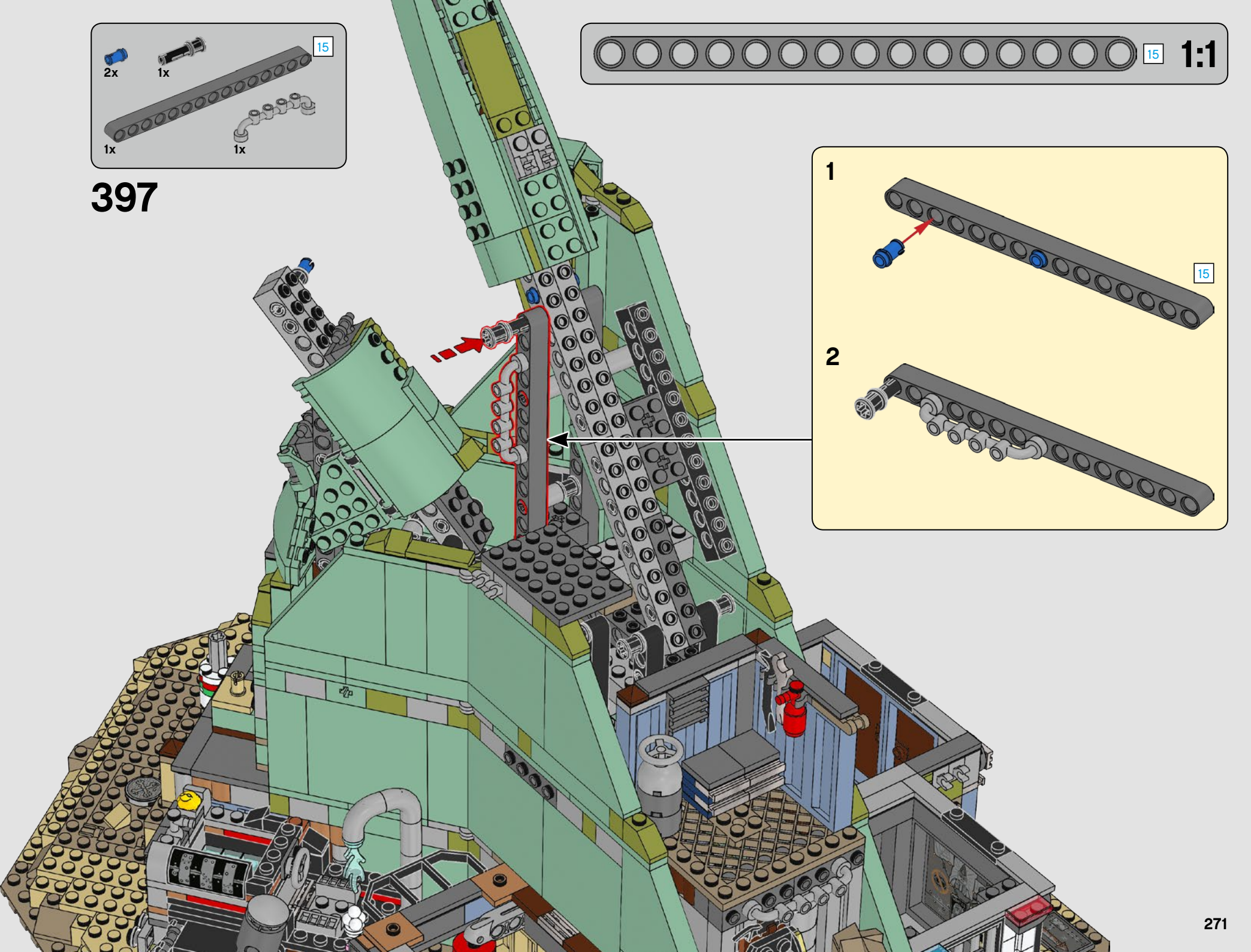
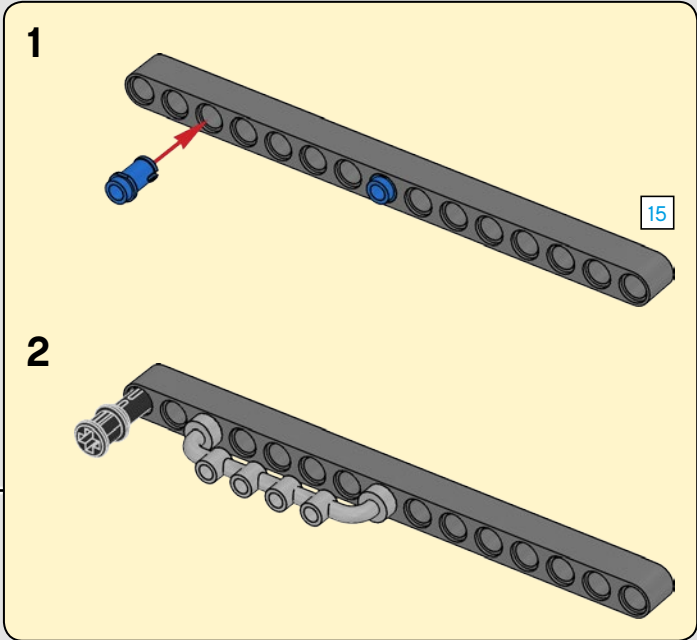
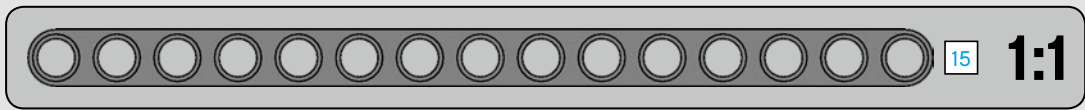

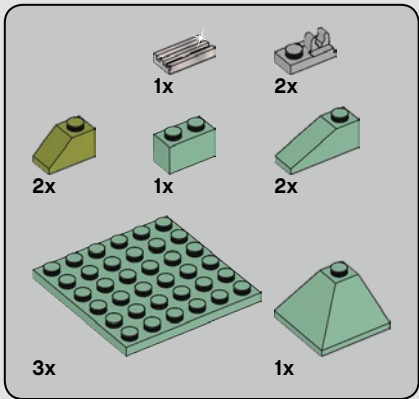

398

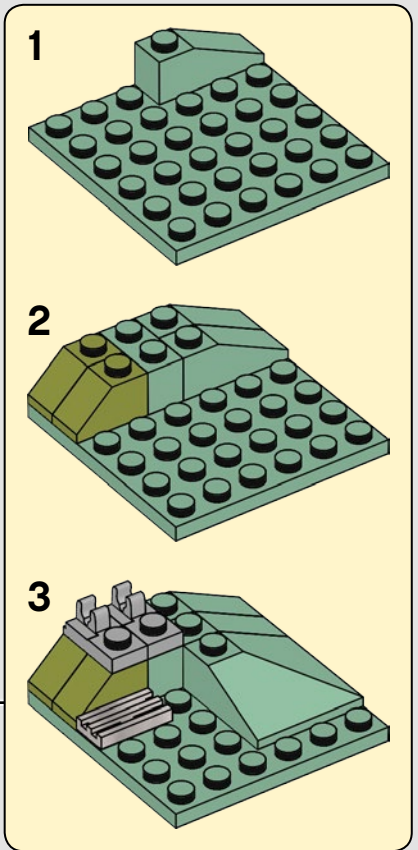
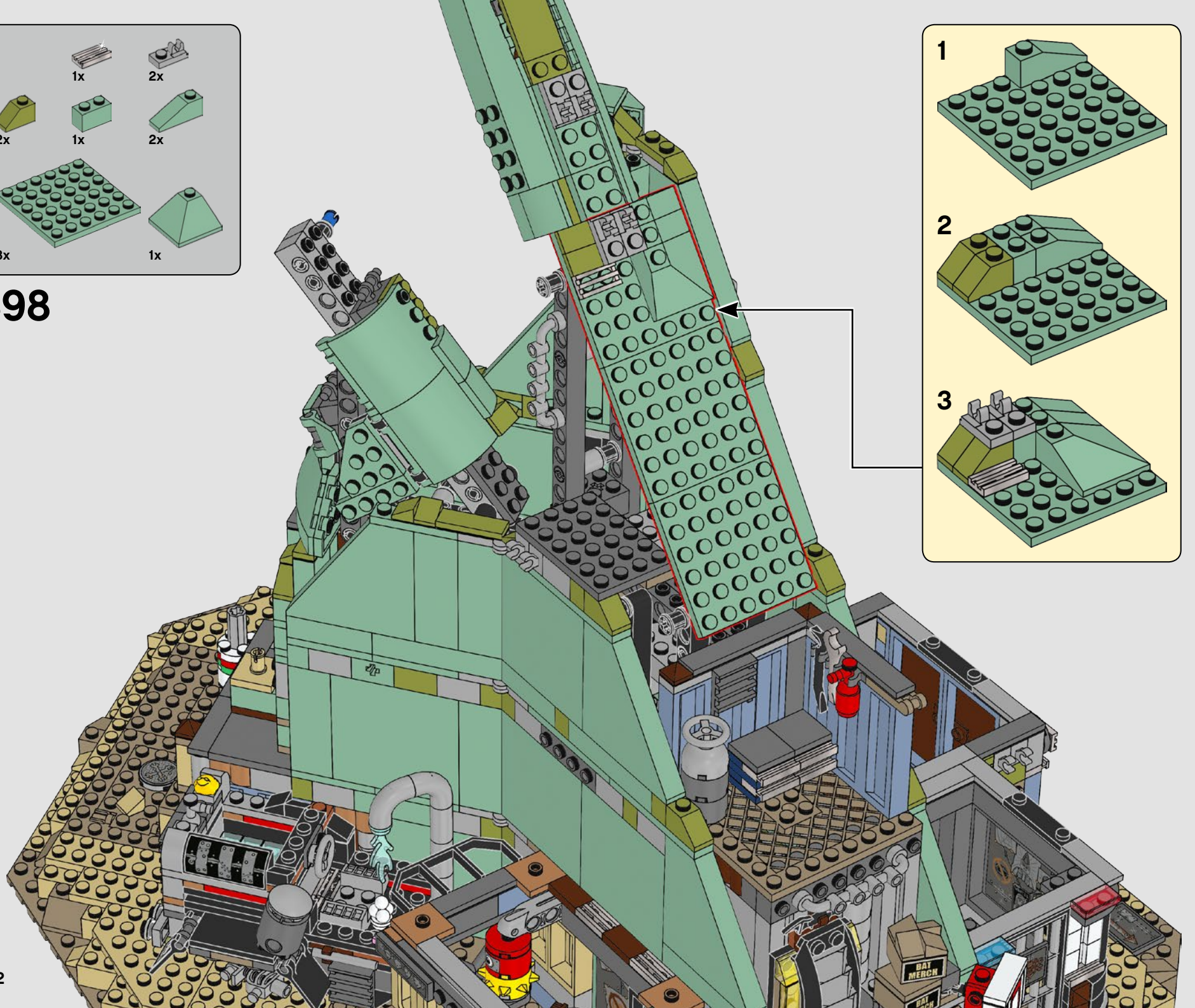



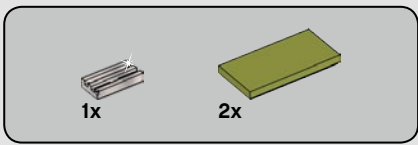

399

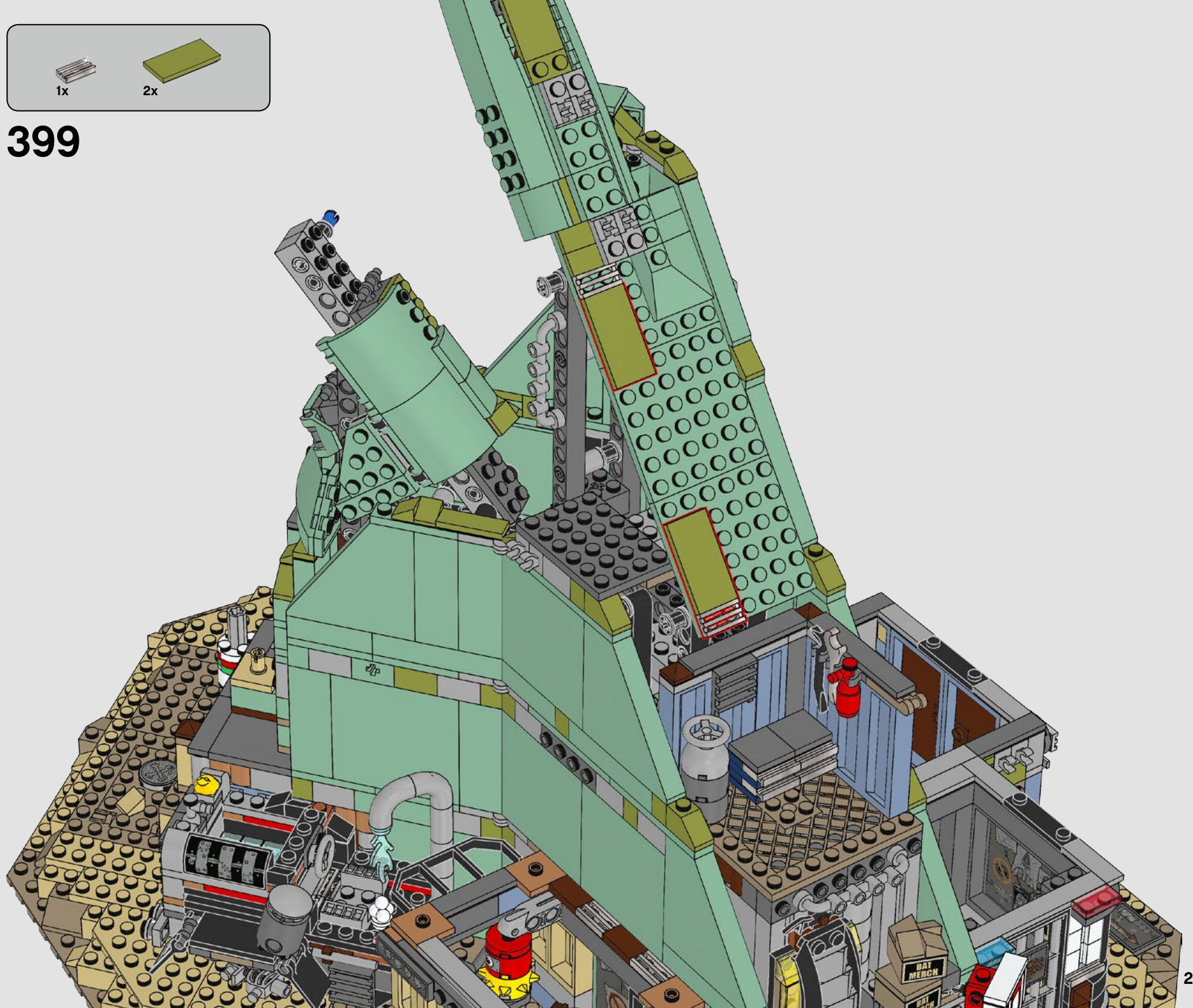

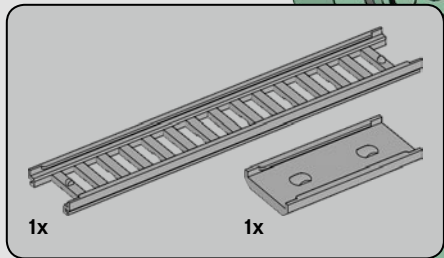

400

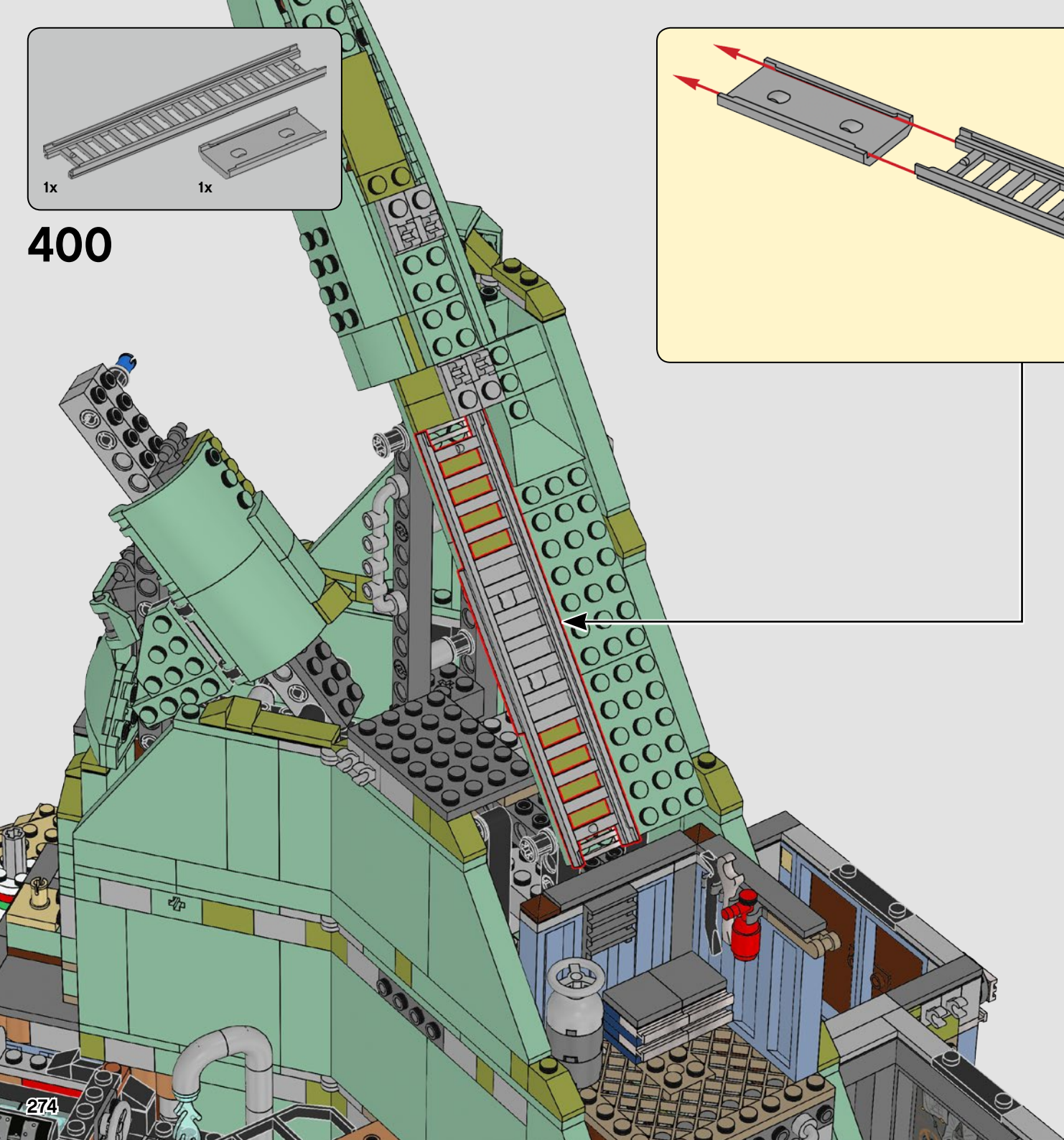
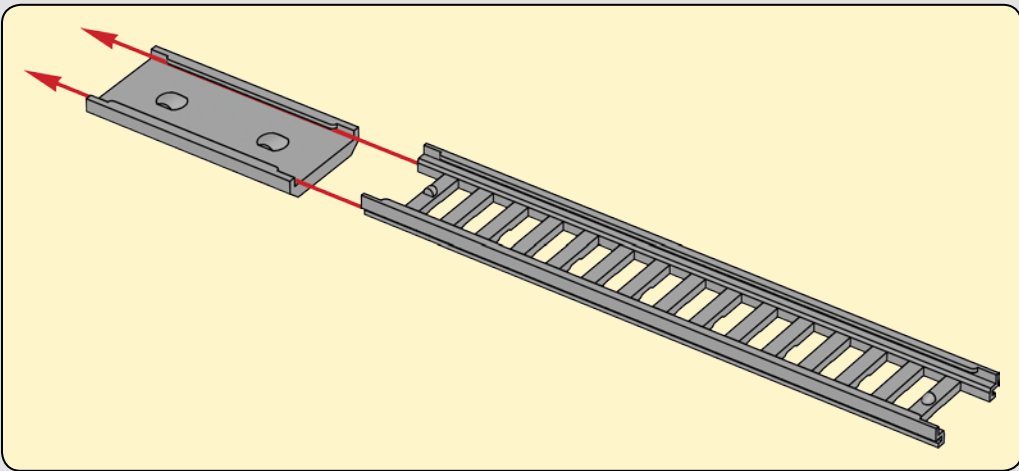

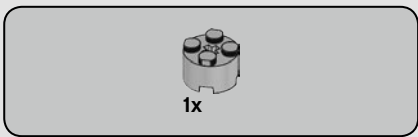

401

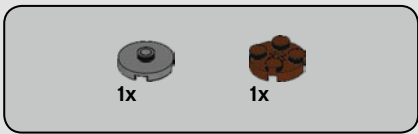

402

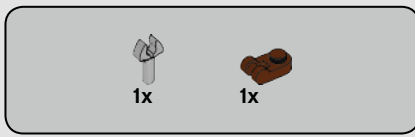

403

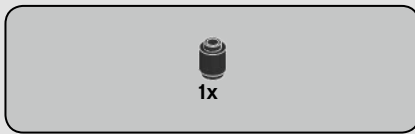

404

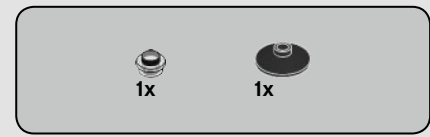

405

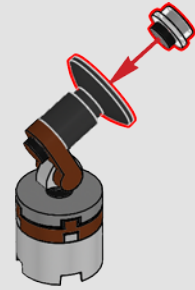

406



407

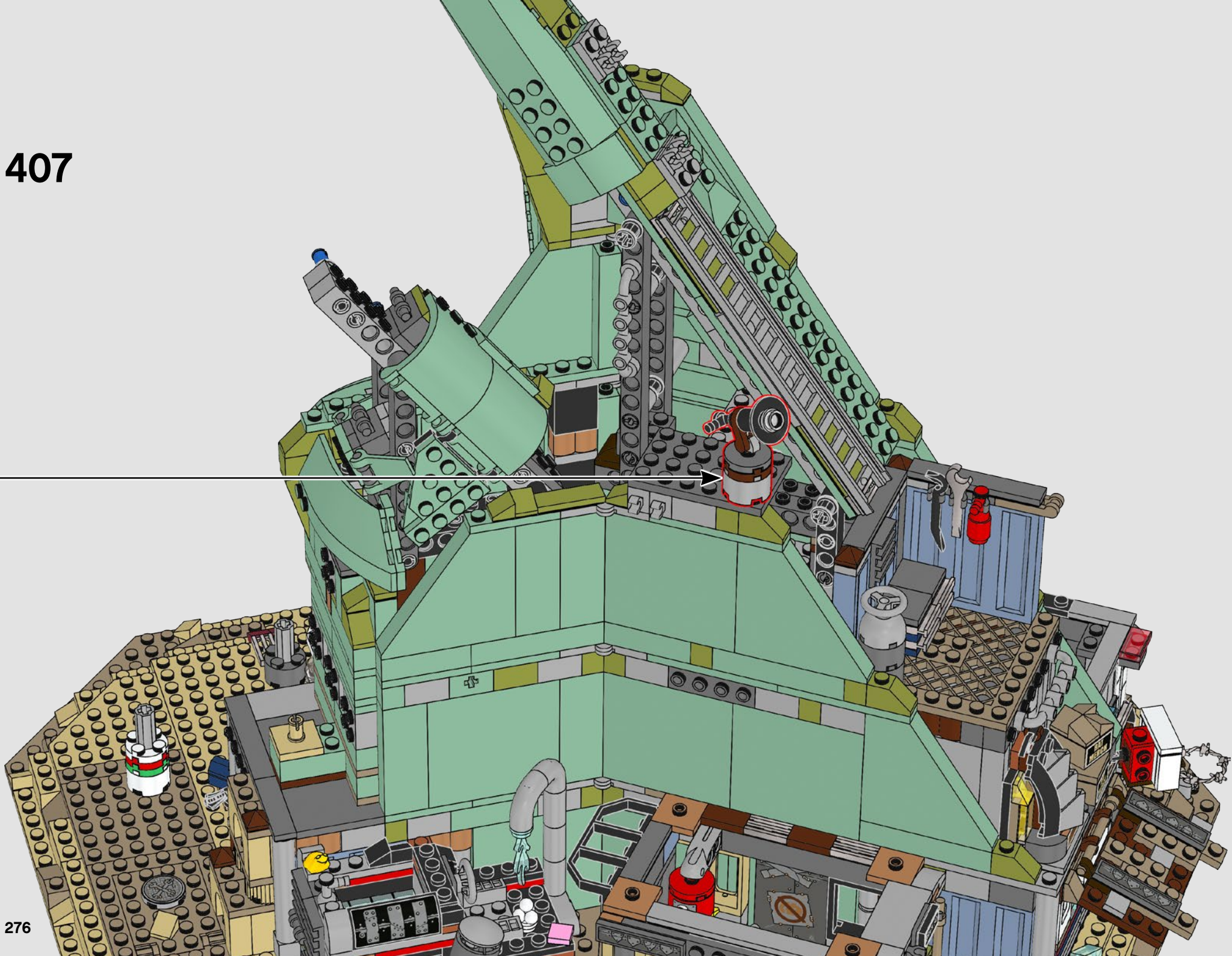

276



11

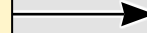
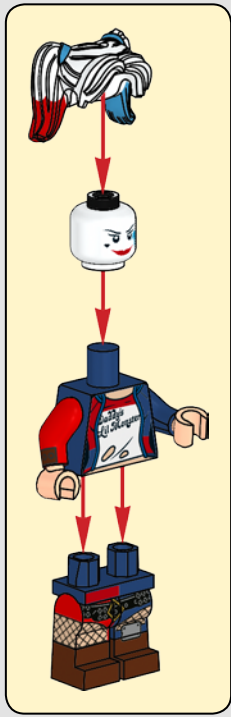
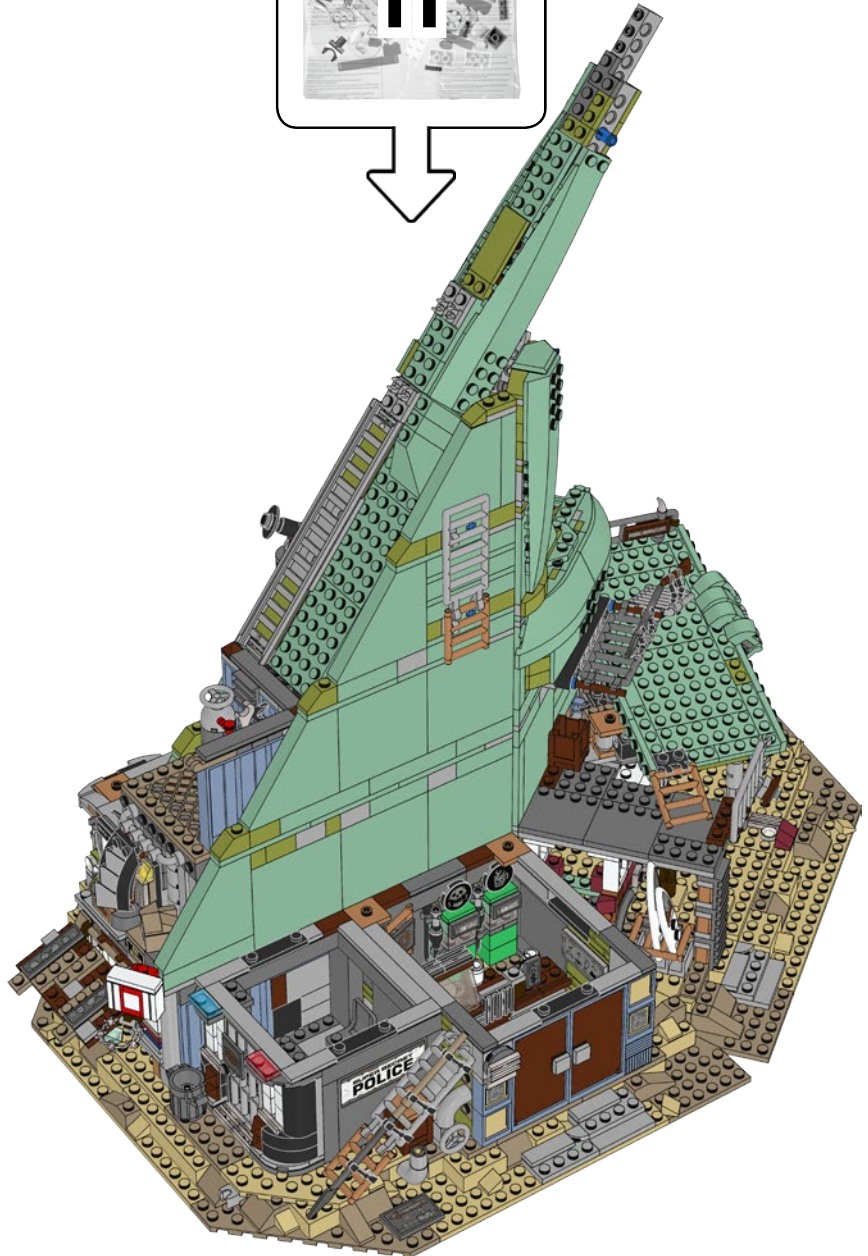

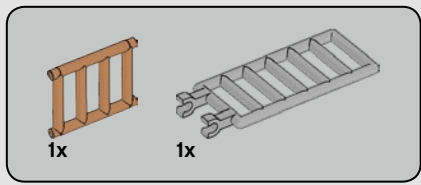

408

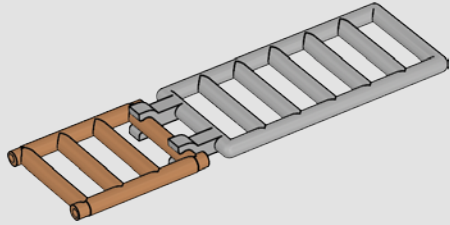

409

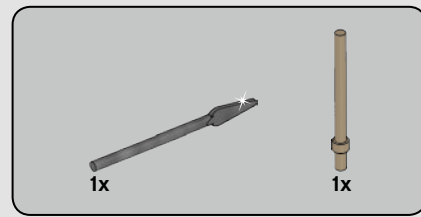
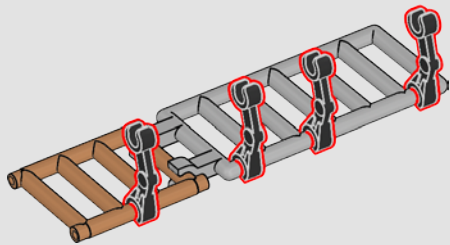

410

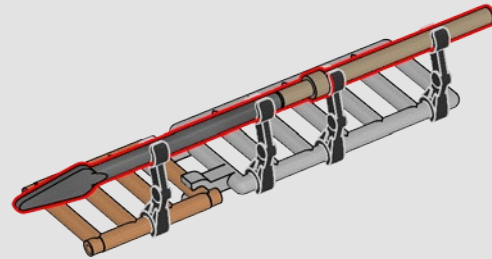

411

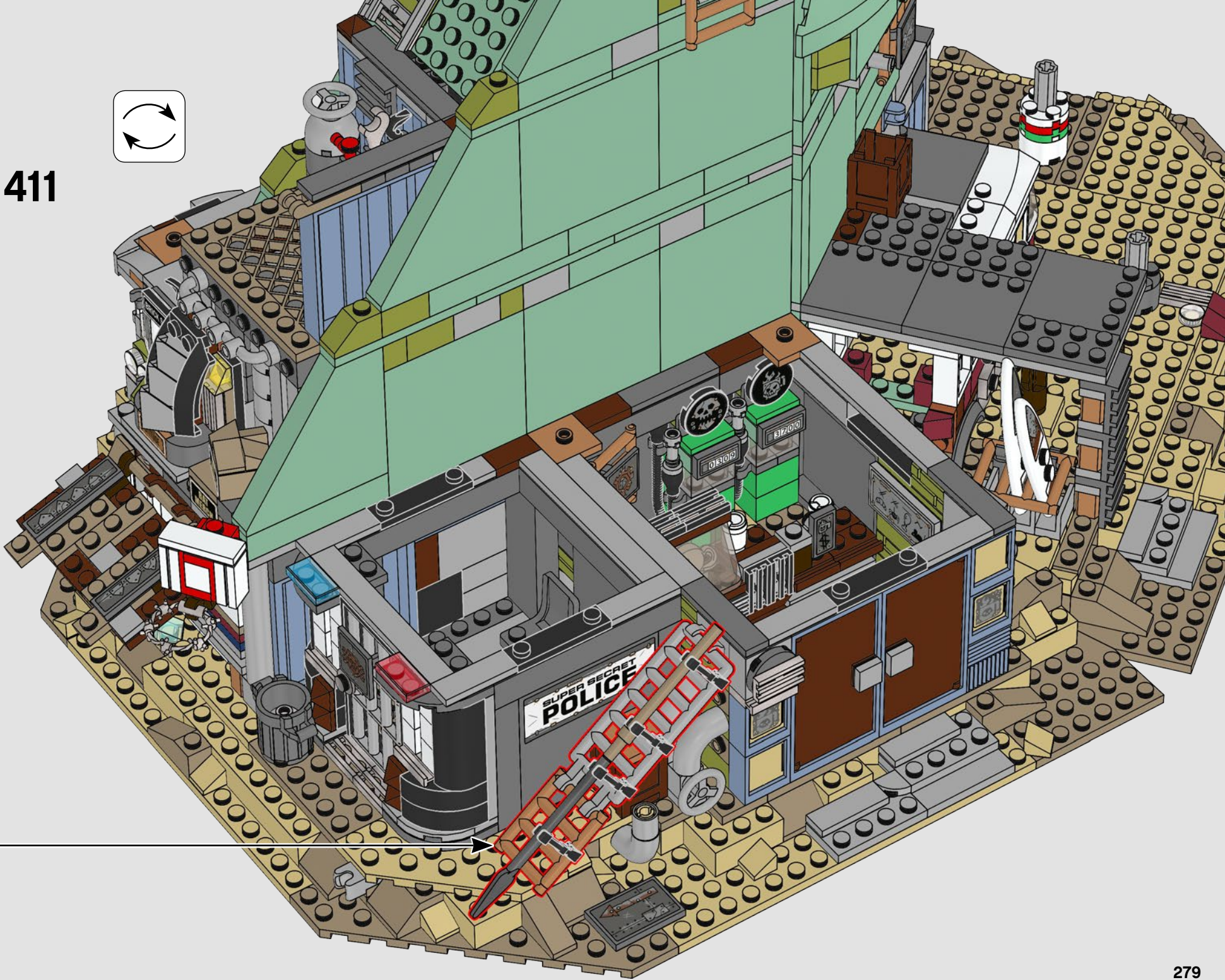
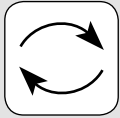

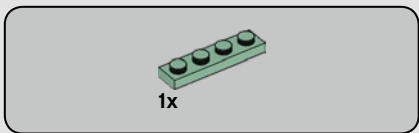

412

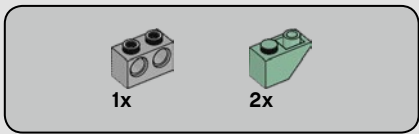
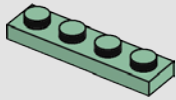

413

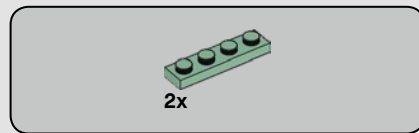
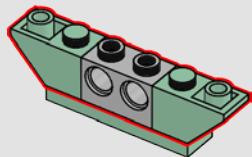

414

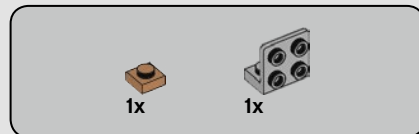
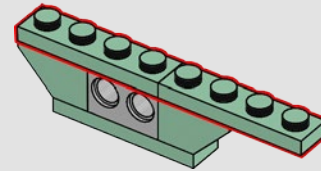

415

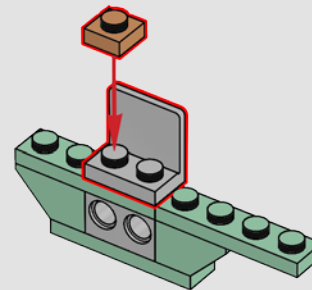



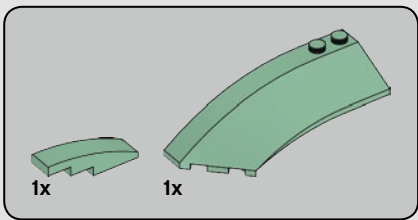

416

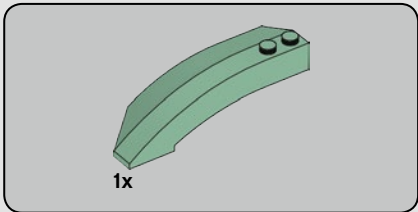
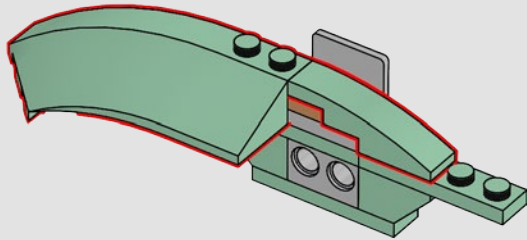

417

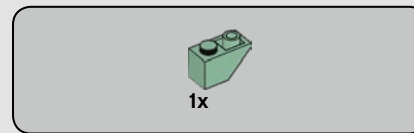
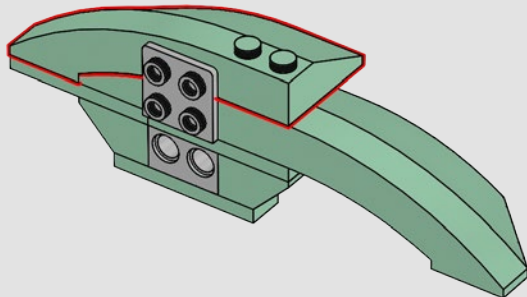
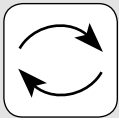

418

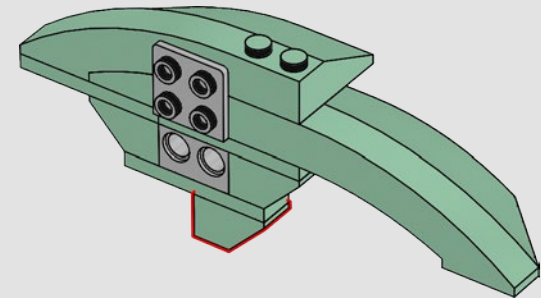

419

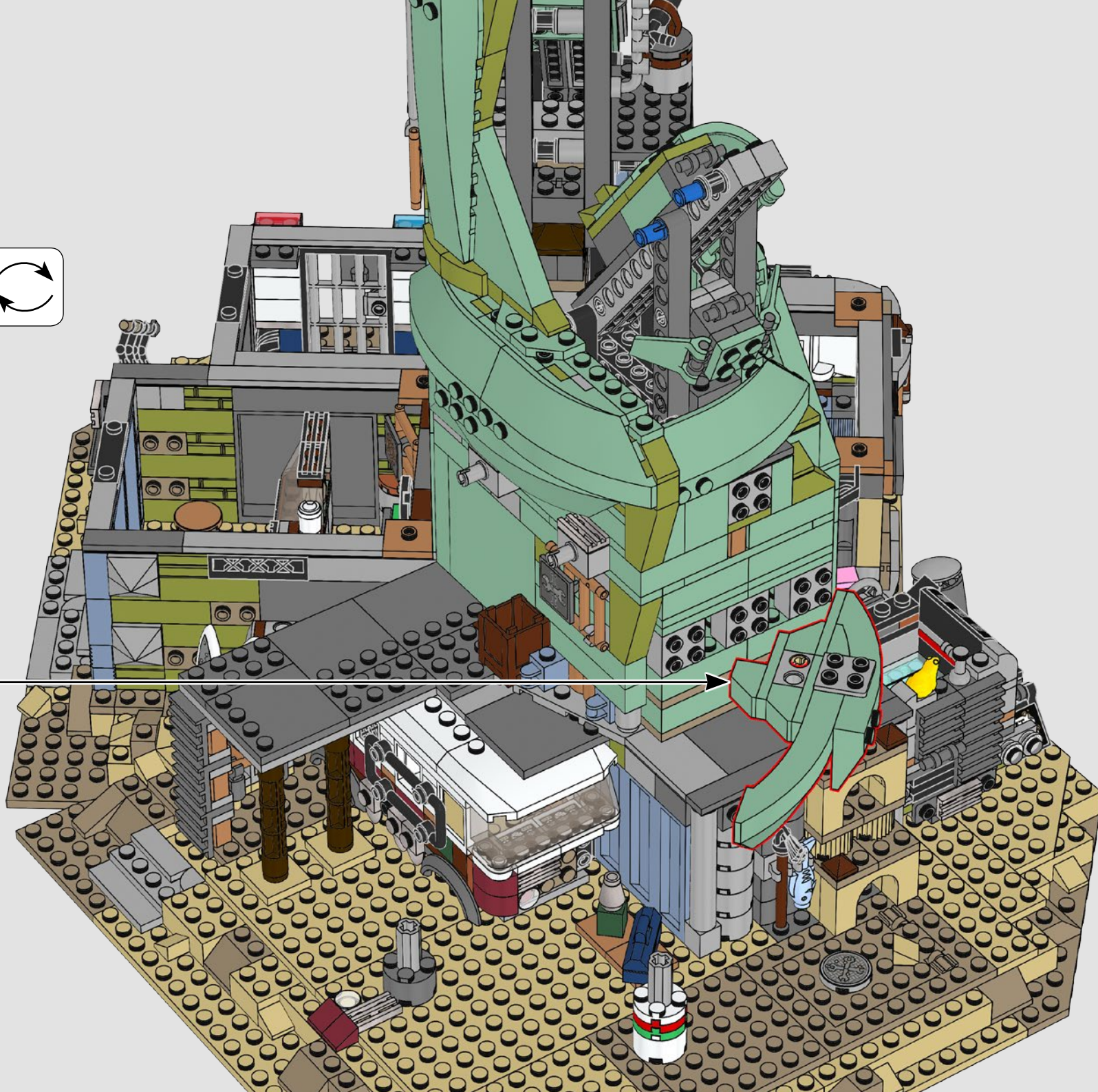
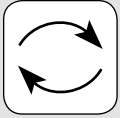

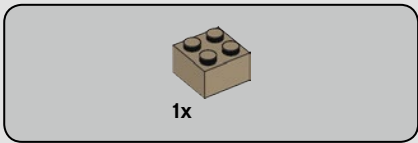

420





1x

# 421

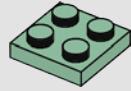

1x



1x

# 422

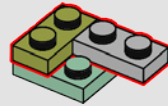

2x

# 423

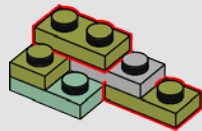

2x

# 424

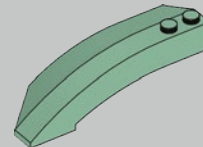
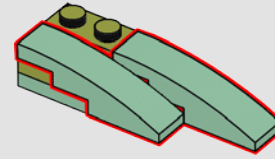

1x

# 425

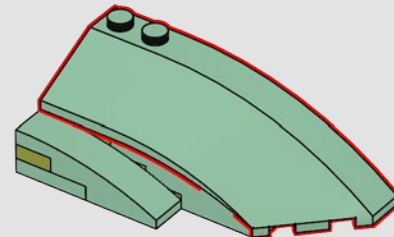

426





1x

427

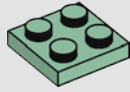

1x



1x

428

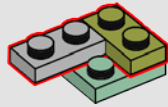

2x

429

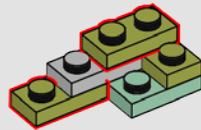

2x

430

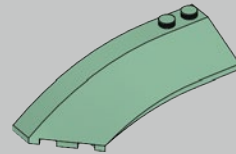
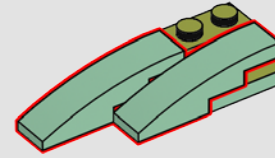

1x

431

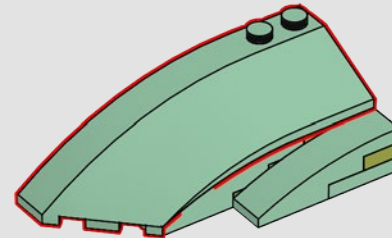

432

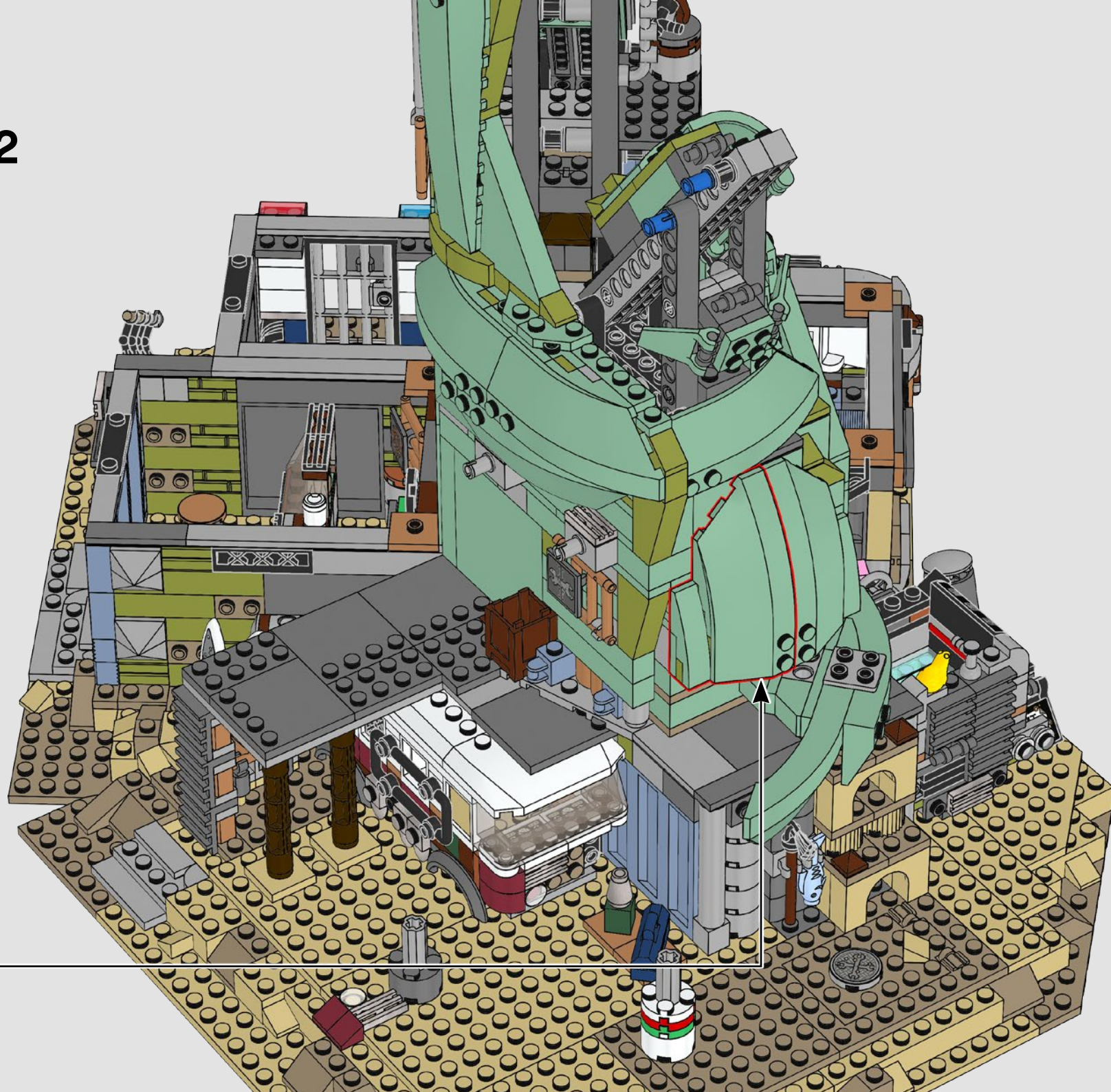

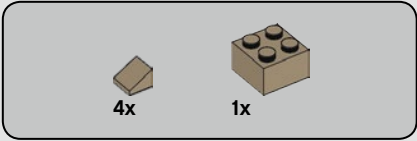

433

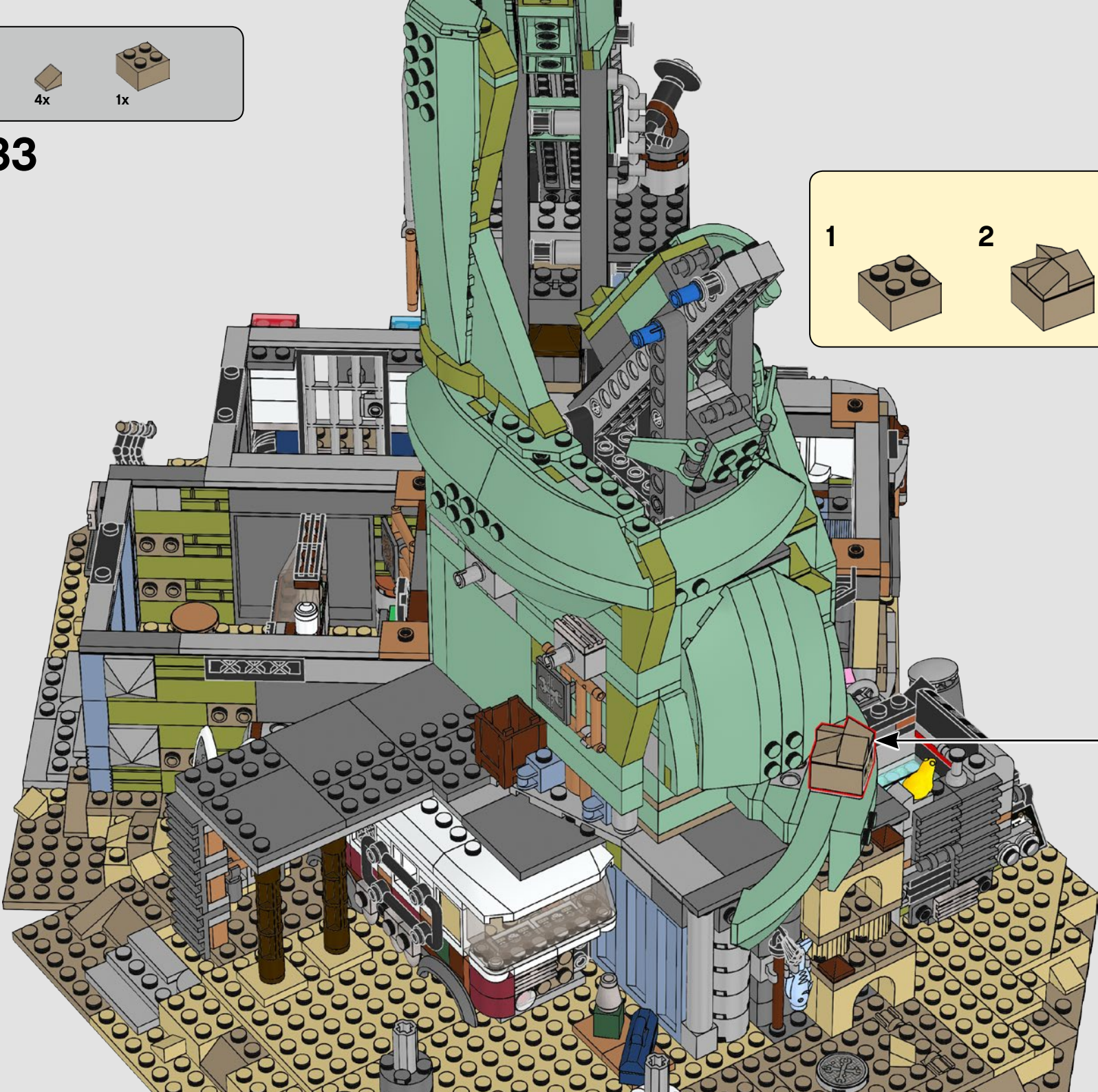
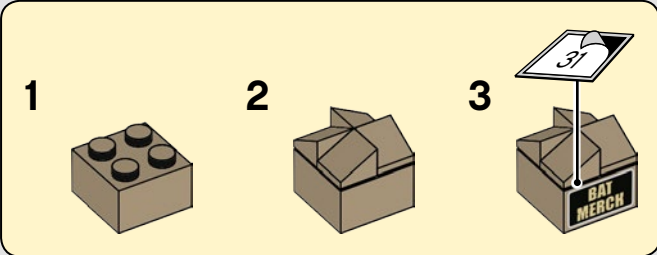



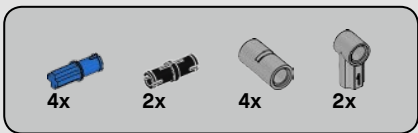

434

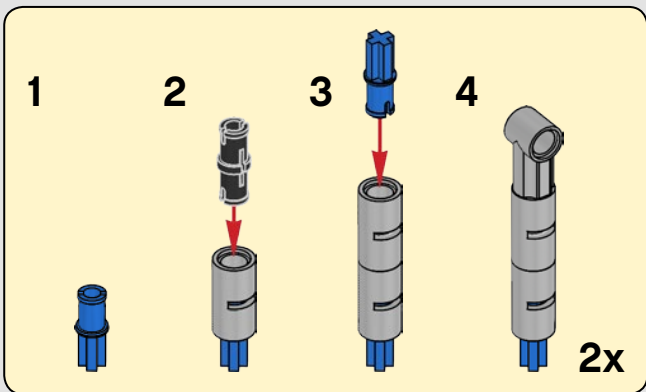
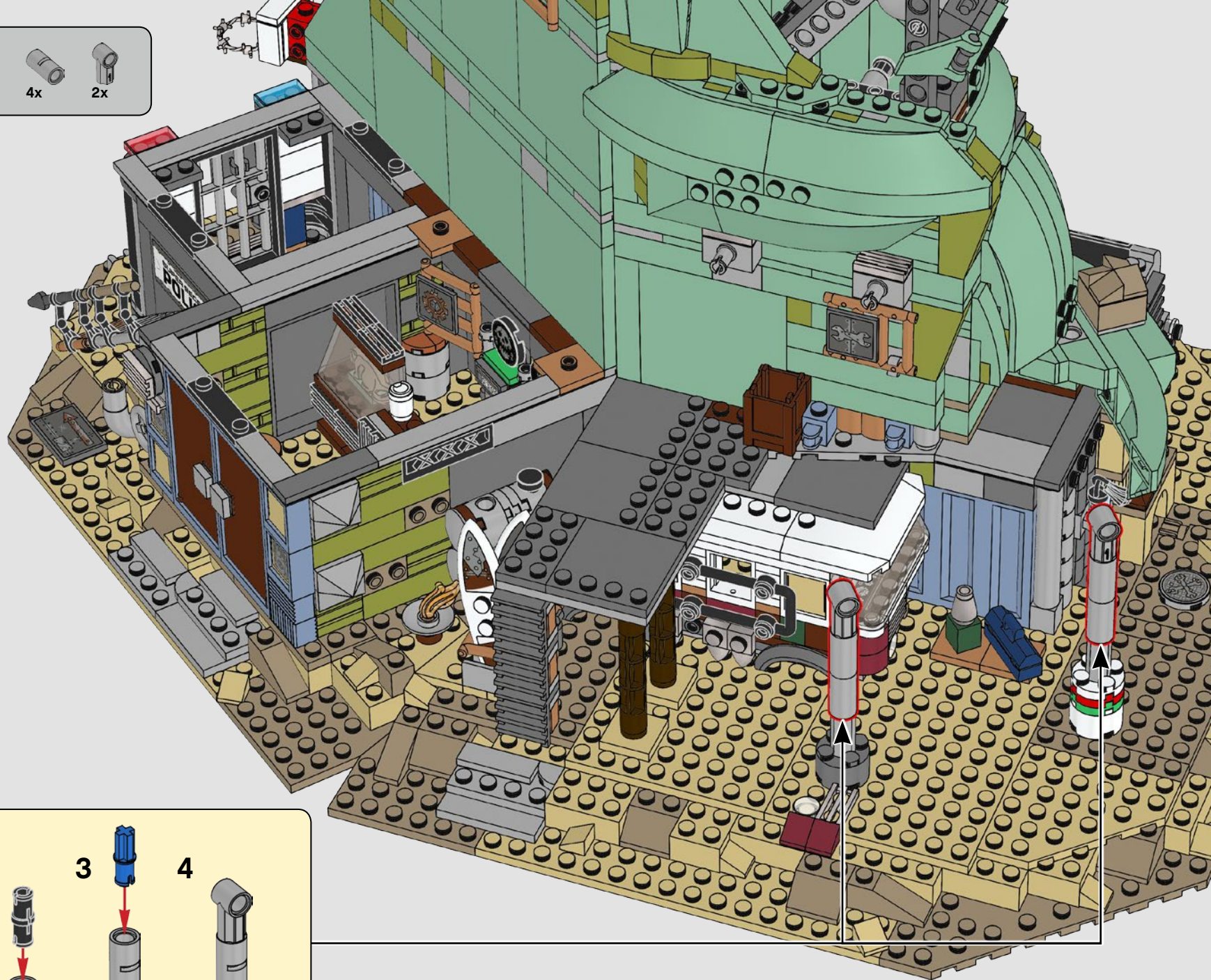

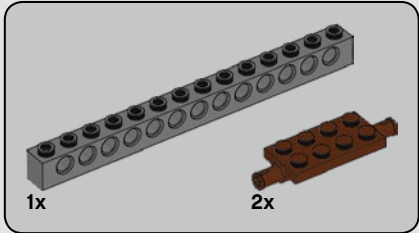
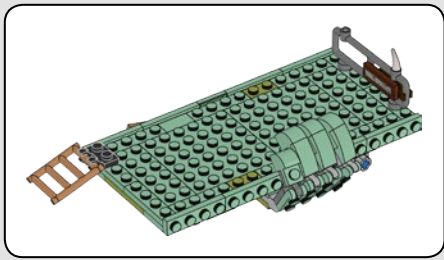

435

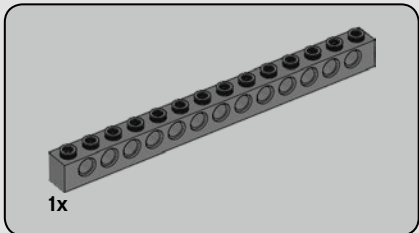
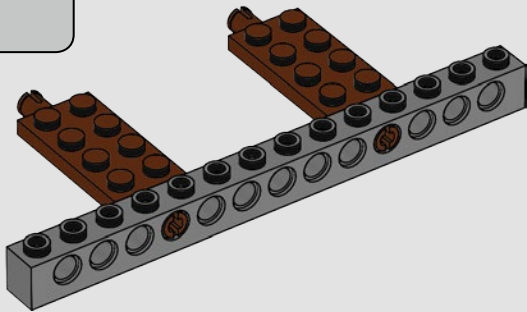

436

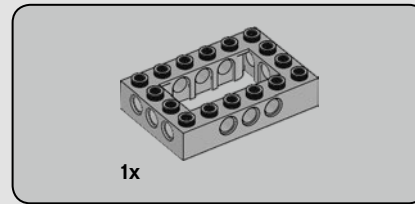
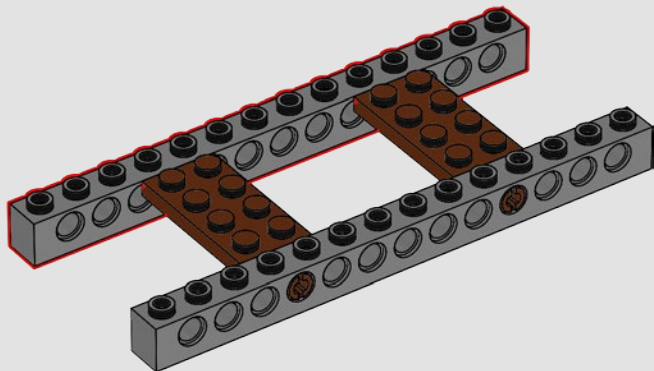

437

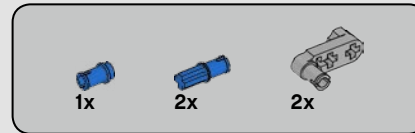
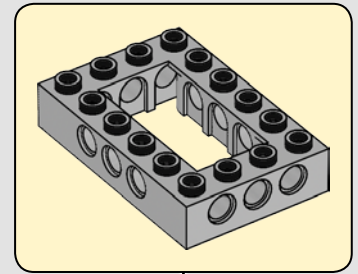
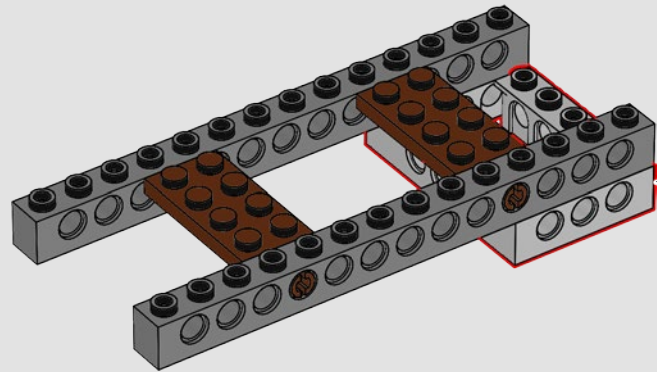

438

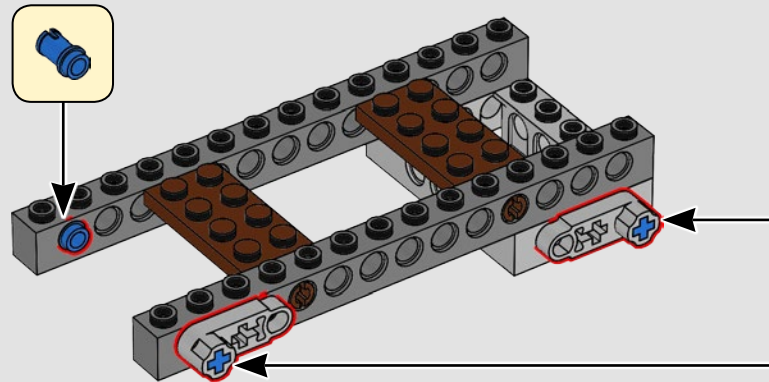
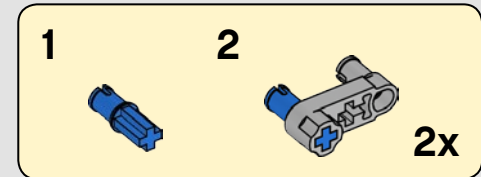

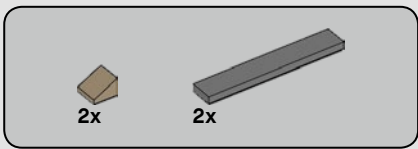

439

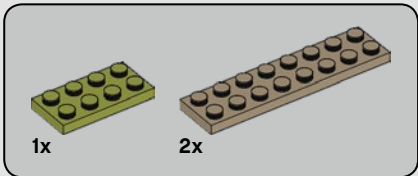
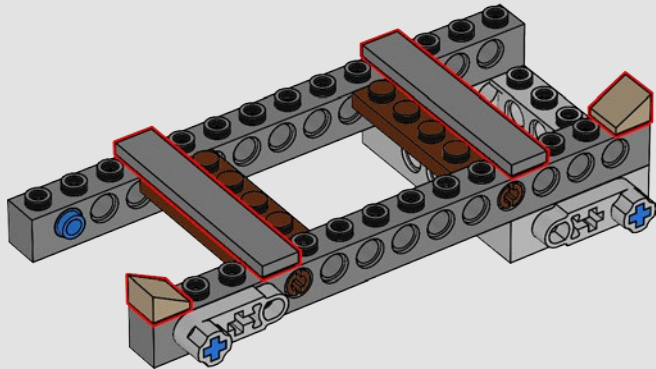

440

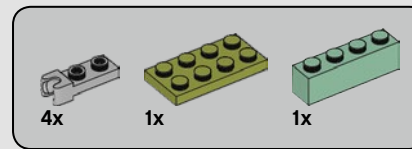
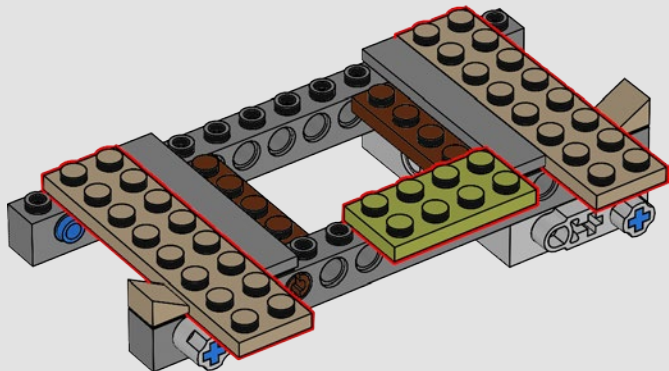

441

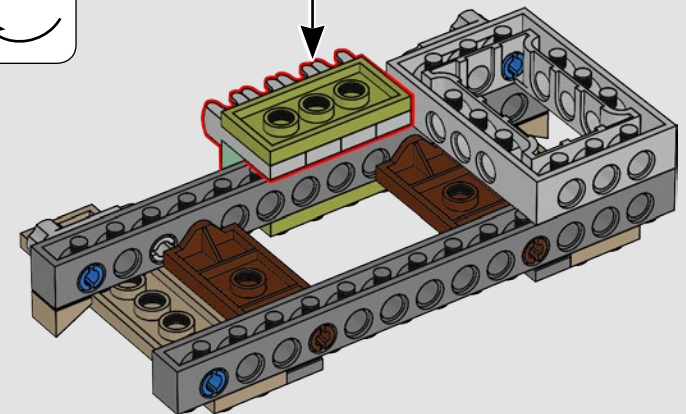
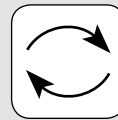
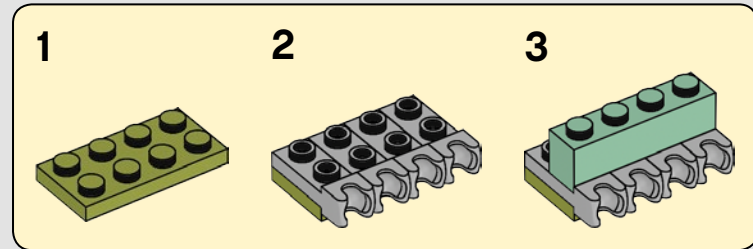

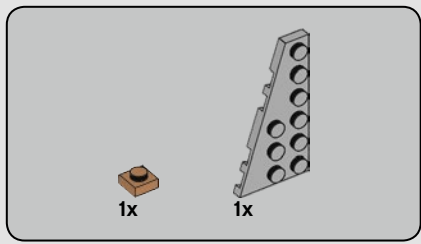

442

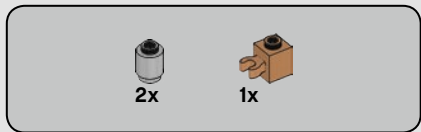
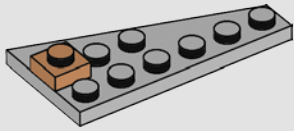

443

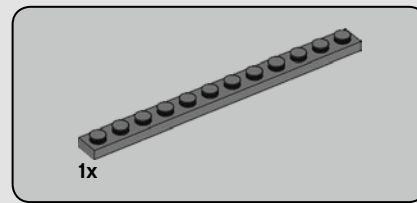
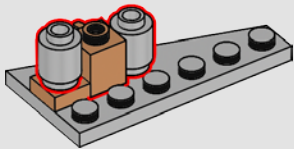

444

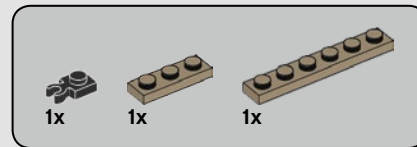
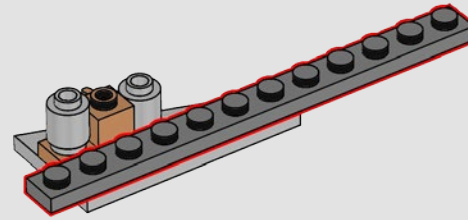

445

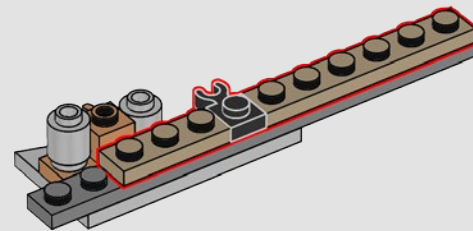

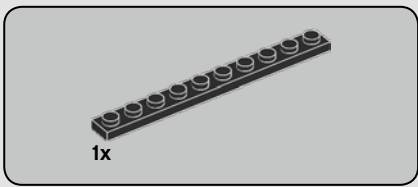

446

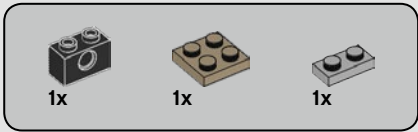
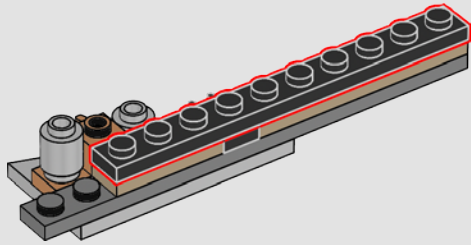

447

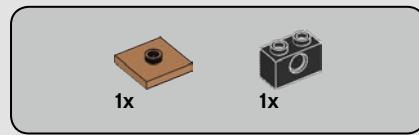
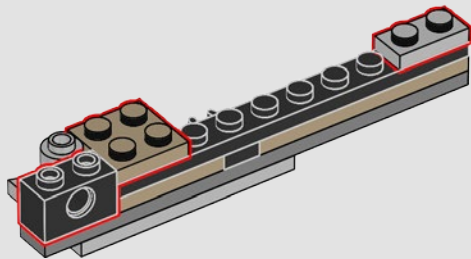

448

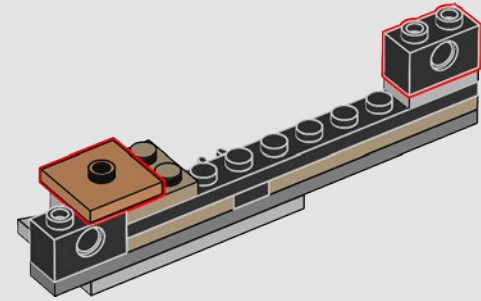

449

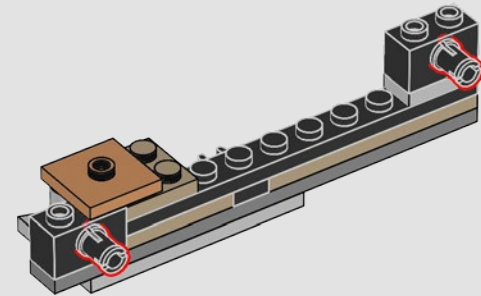

450

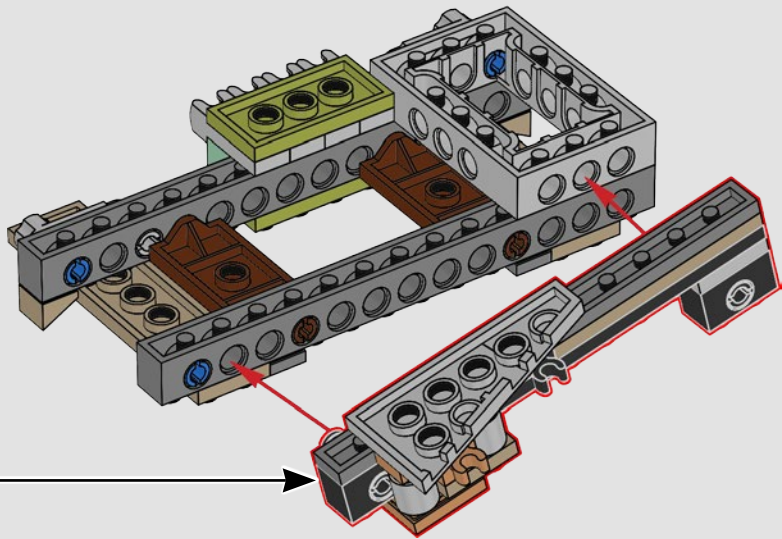

451

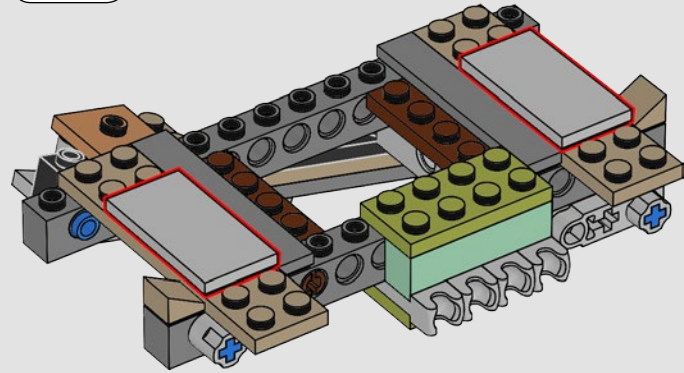
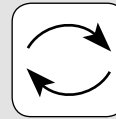
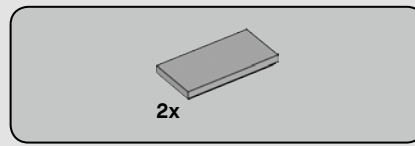

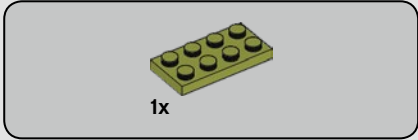
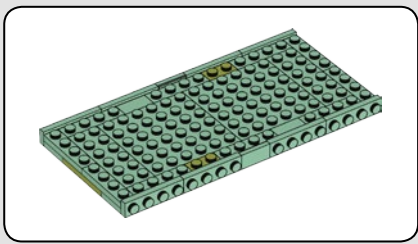

452

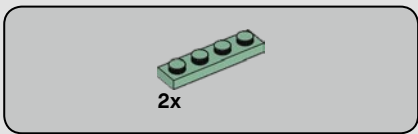
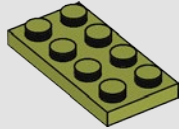

453

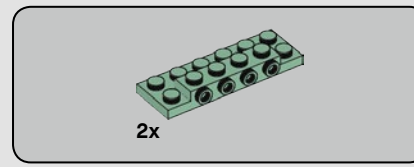
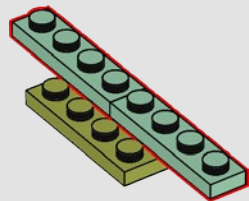

454

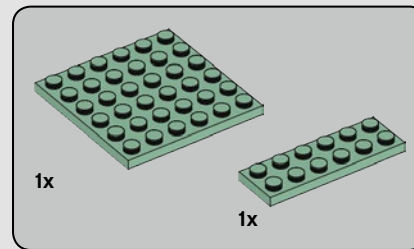
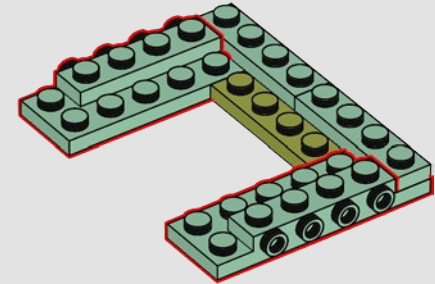

455

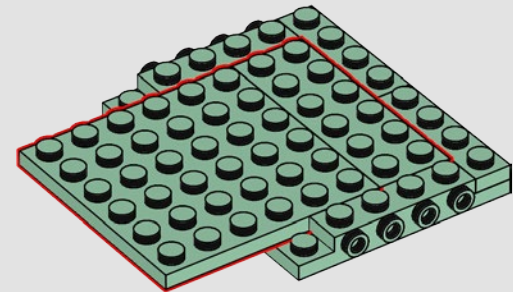

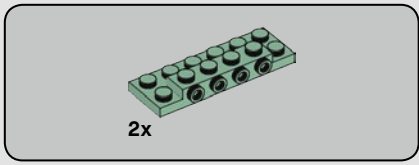

456

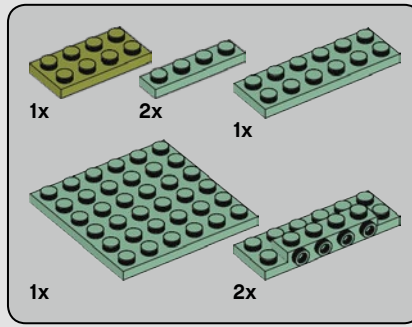
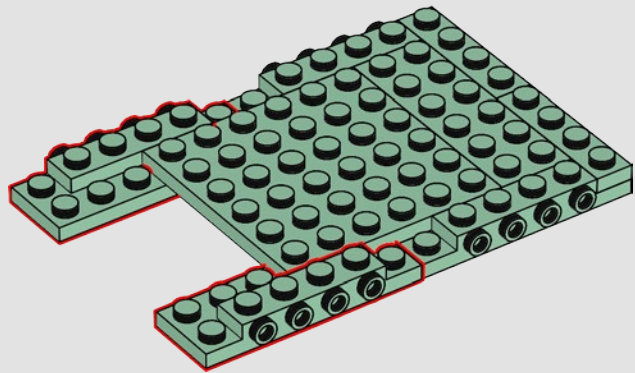

457

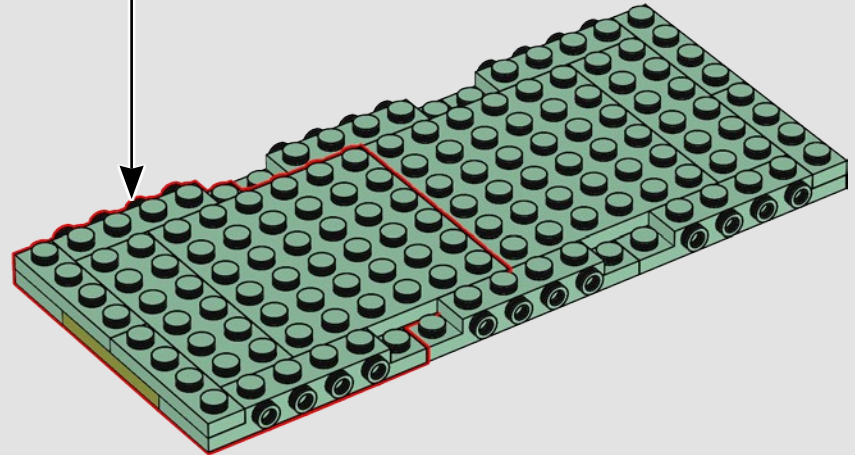
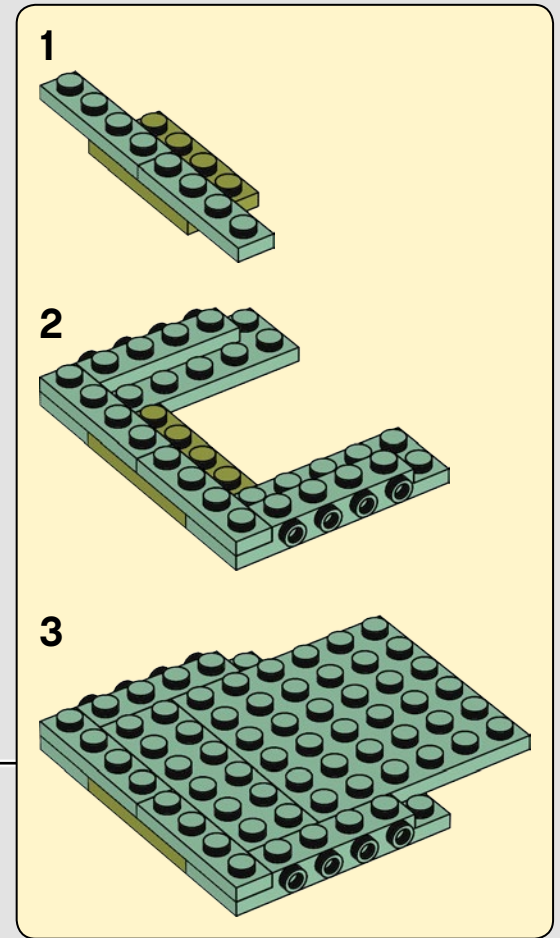



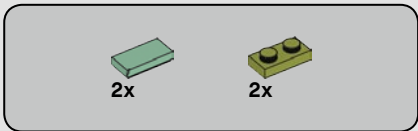

458

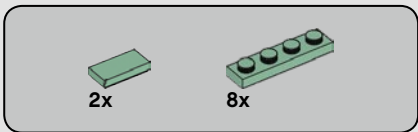
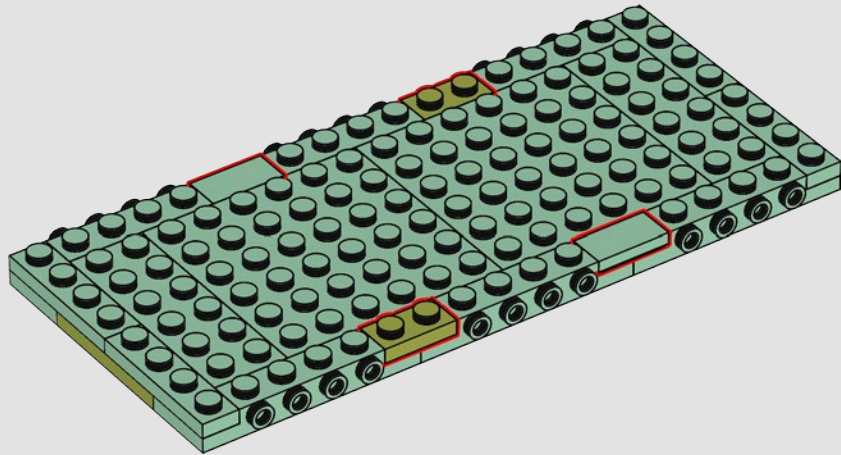

459

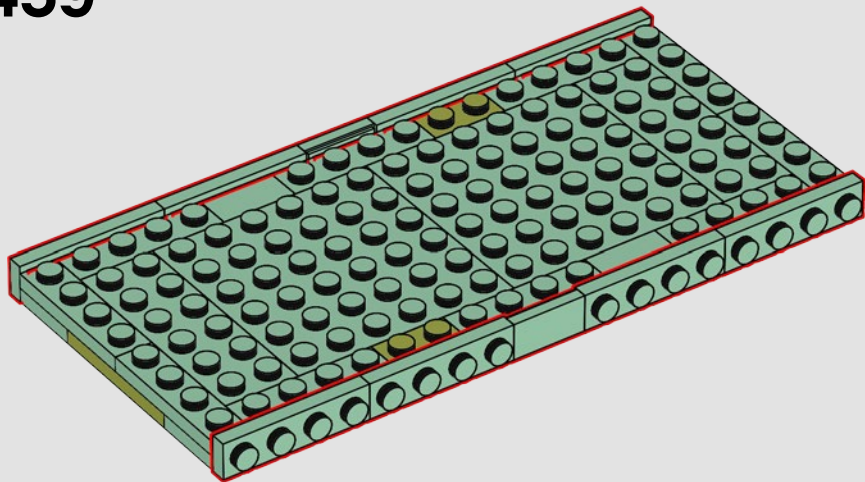

460

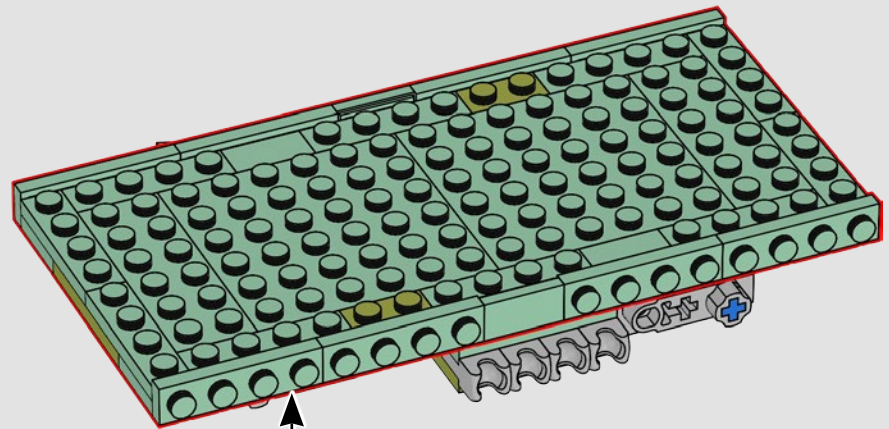

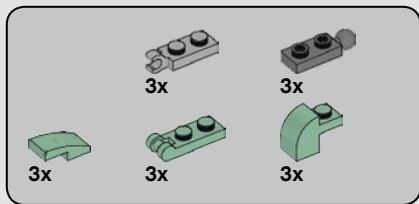

# 461

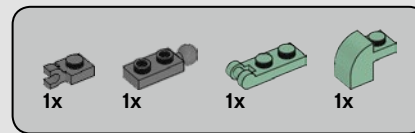
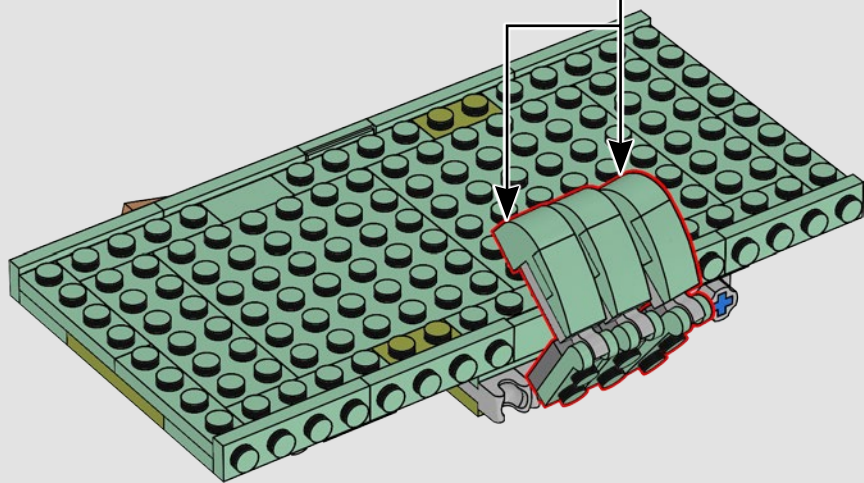
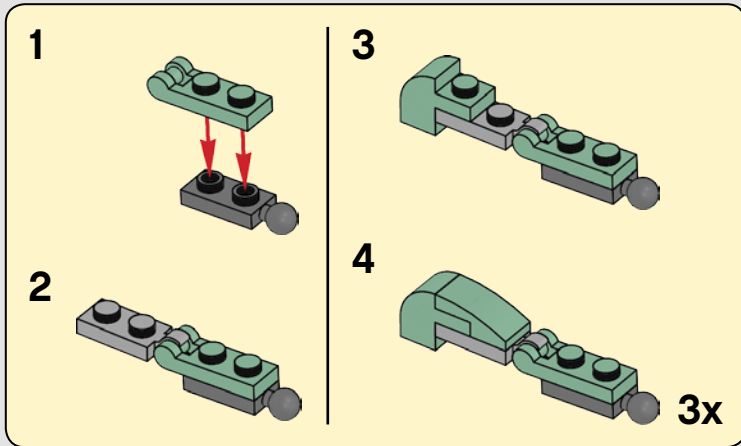

# 462

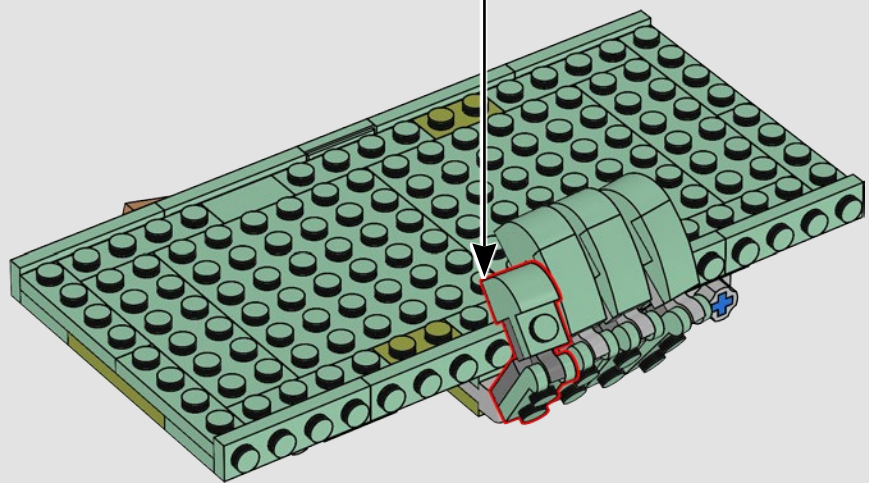
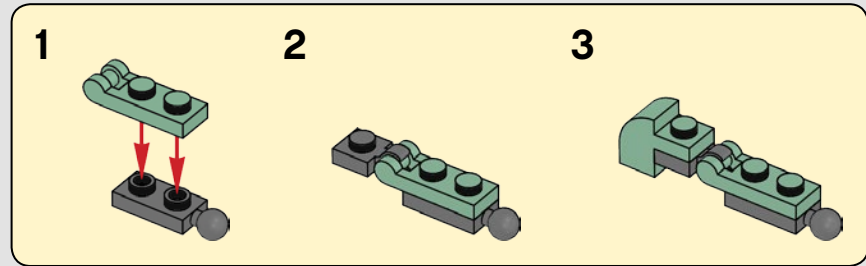

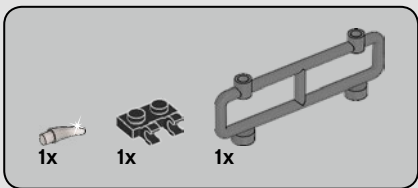

463

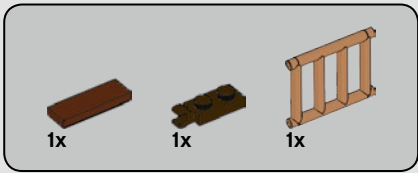
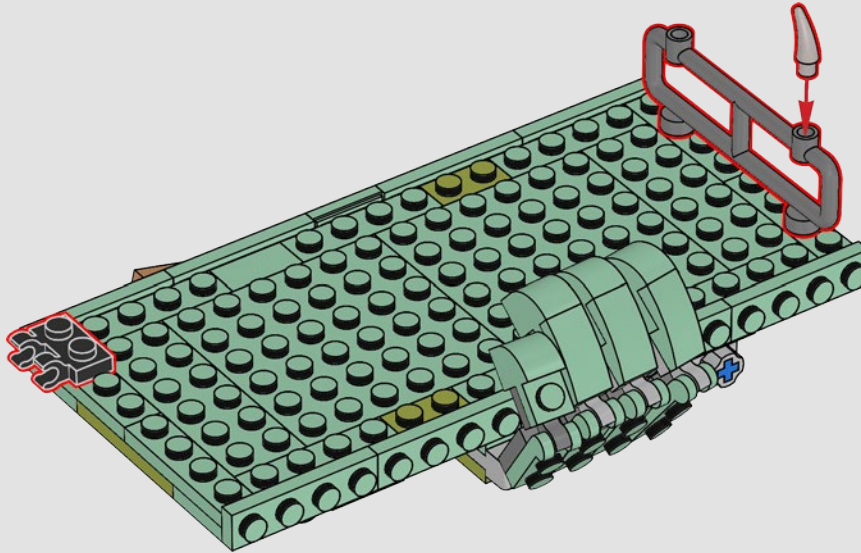

464

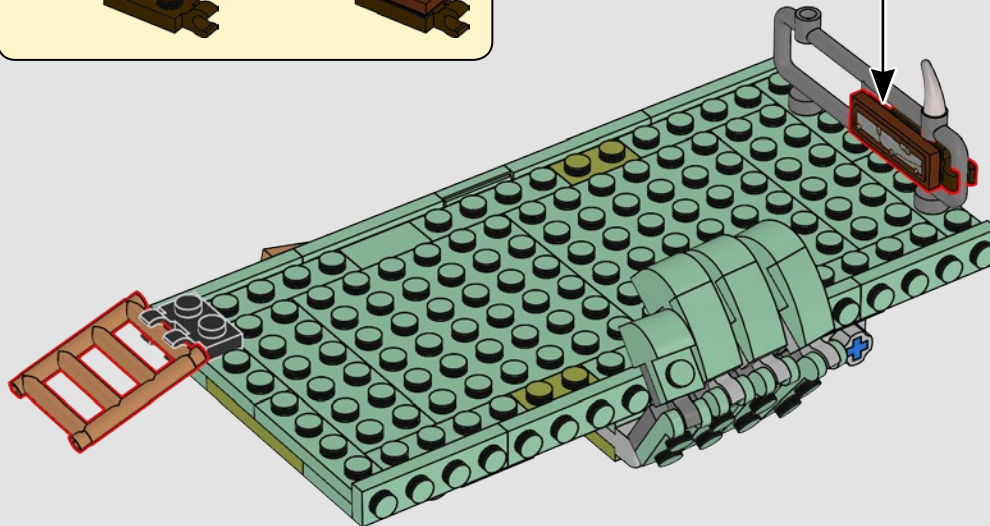
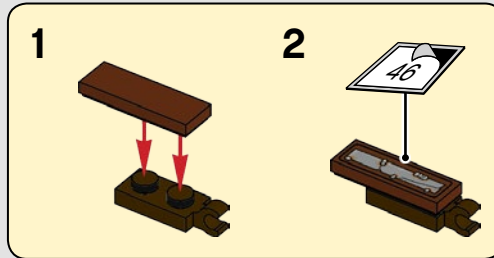

465

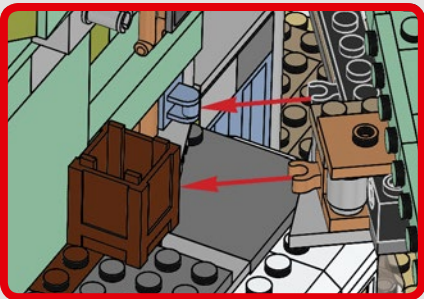
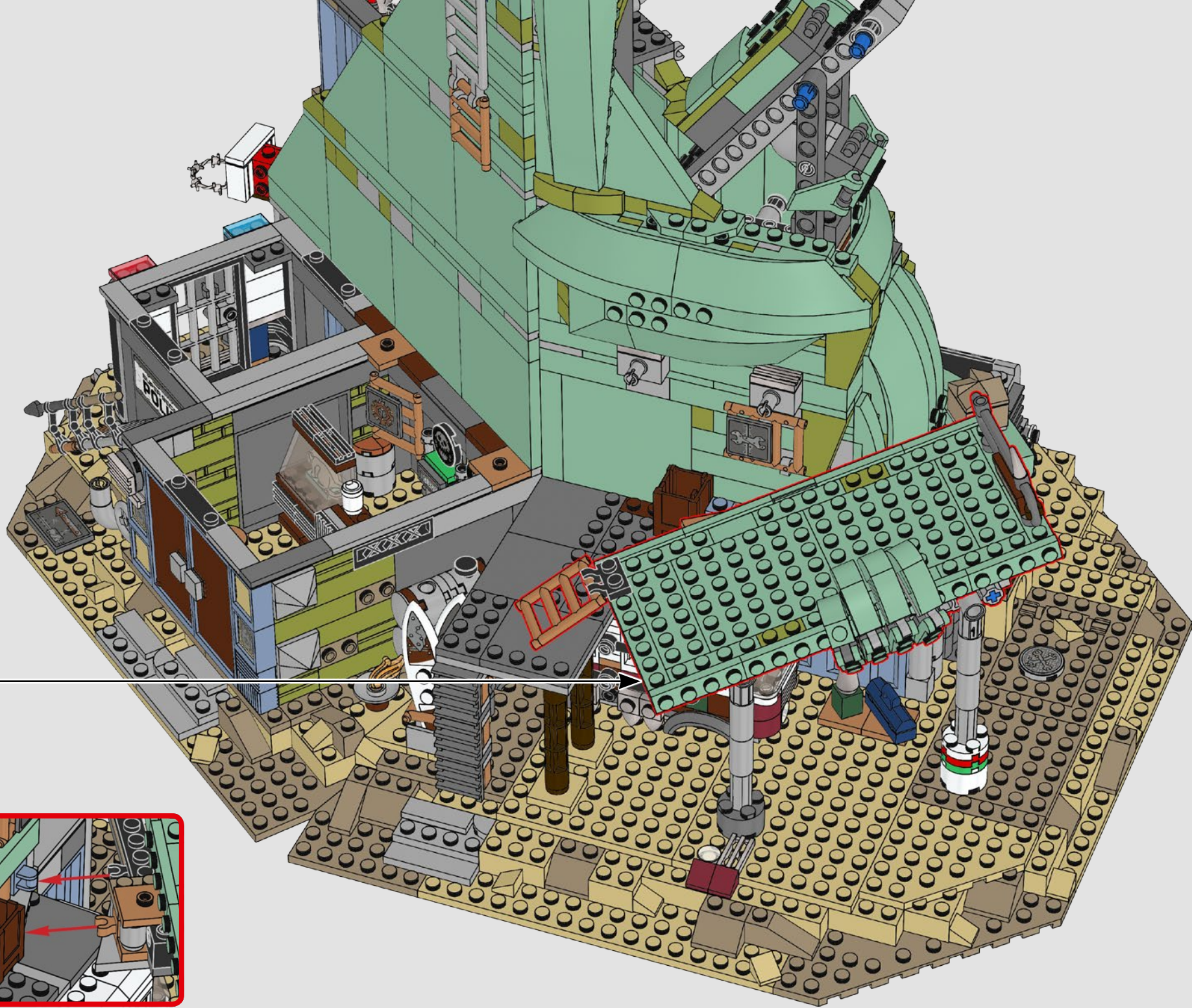

3 1:1

1x  
1x  
2x  
2x  
1x  
3  
1x

466

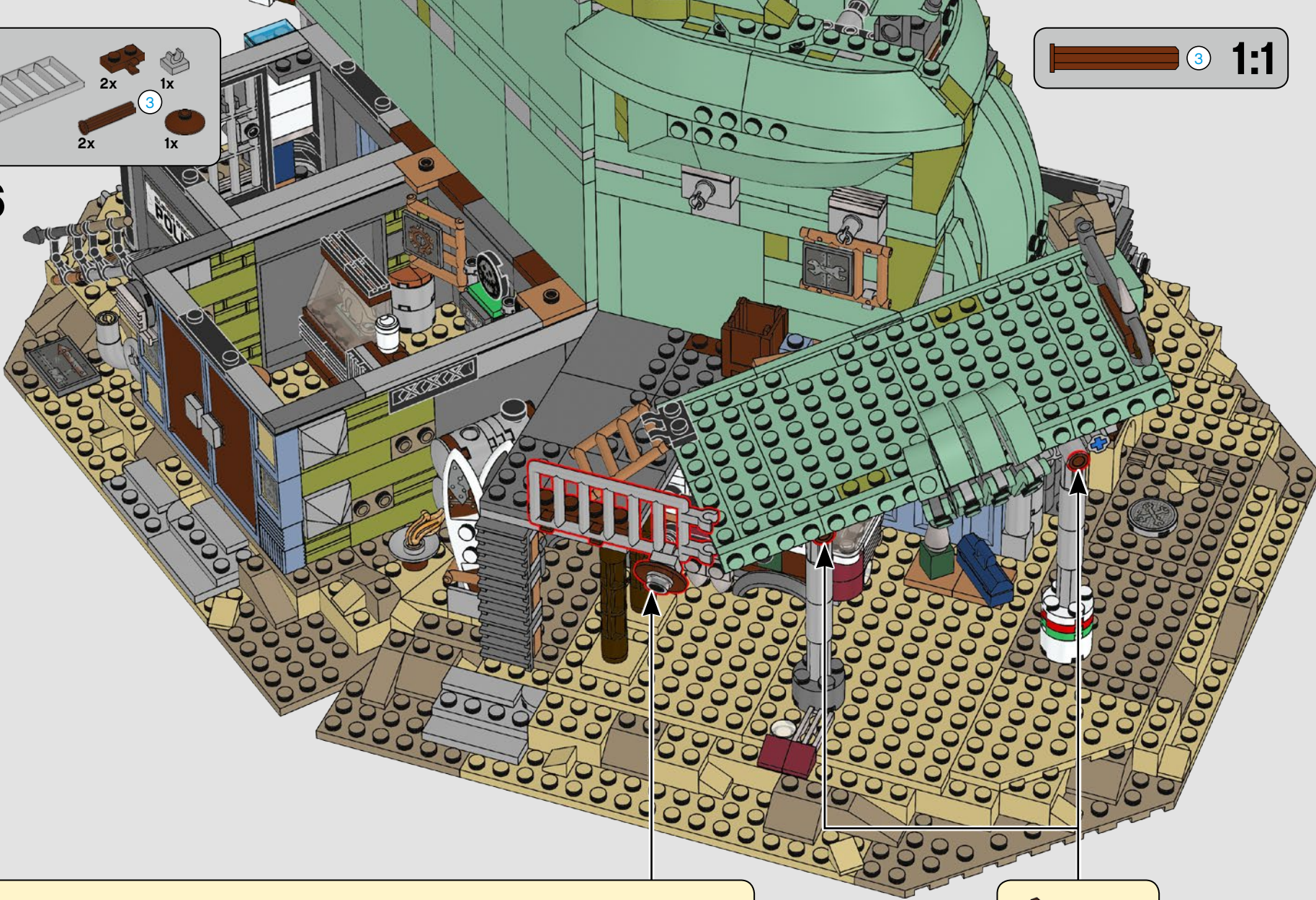

1 2 3 4

3 2x

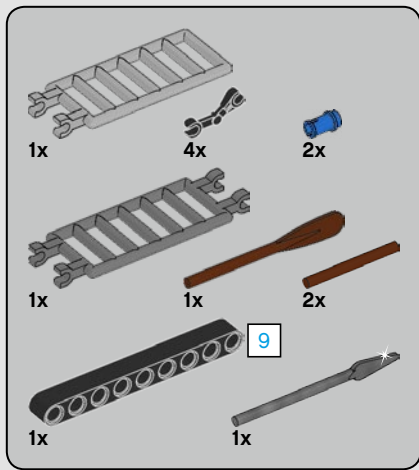

467

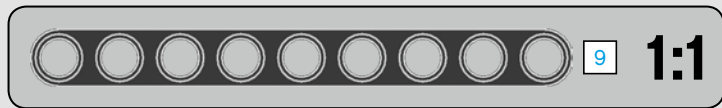
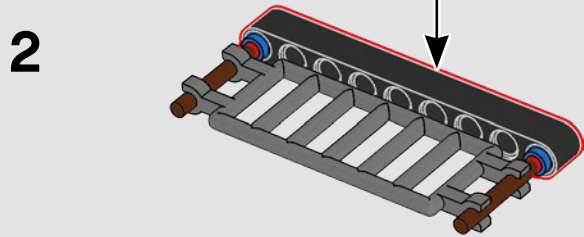
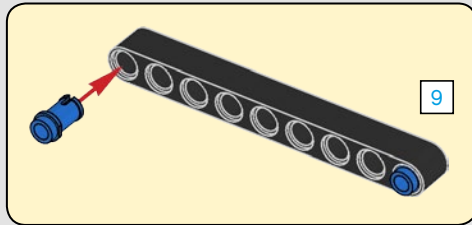
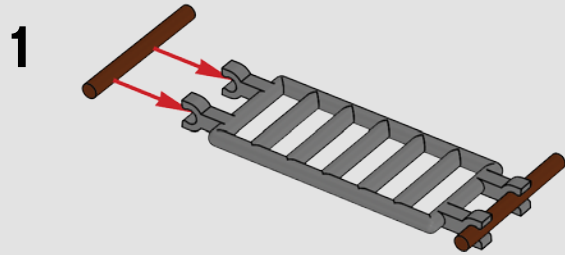

3

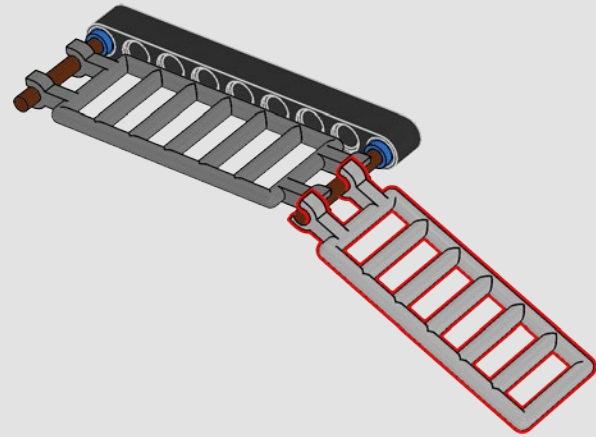

4

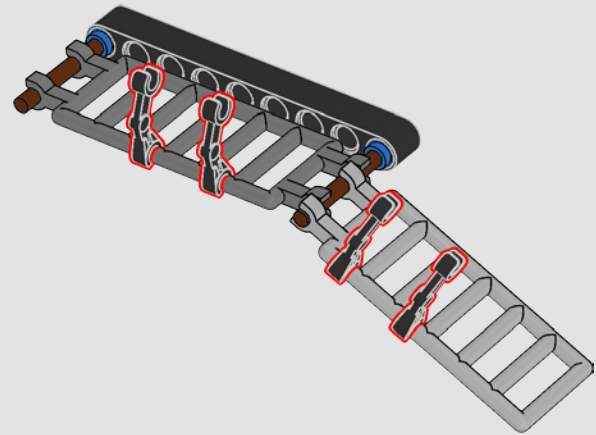

5

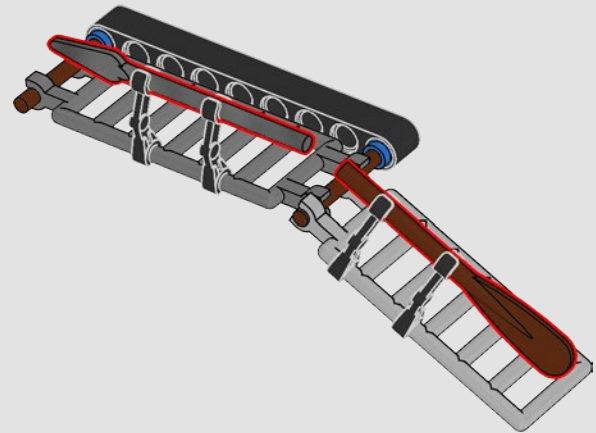

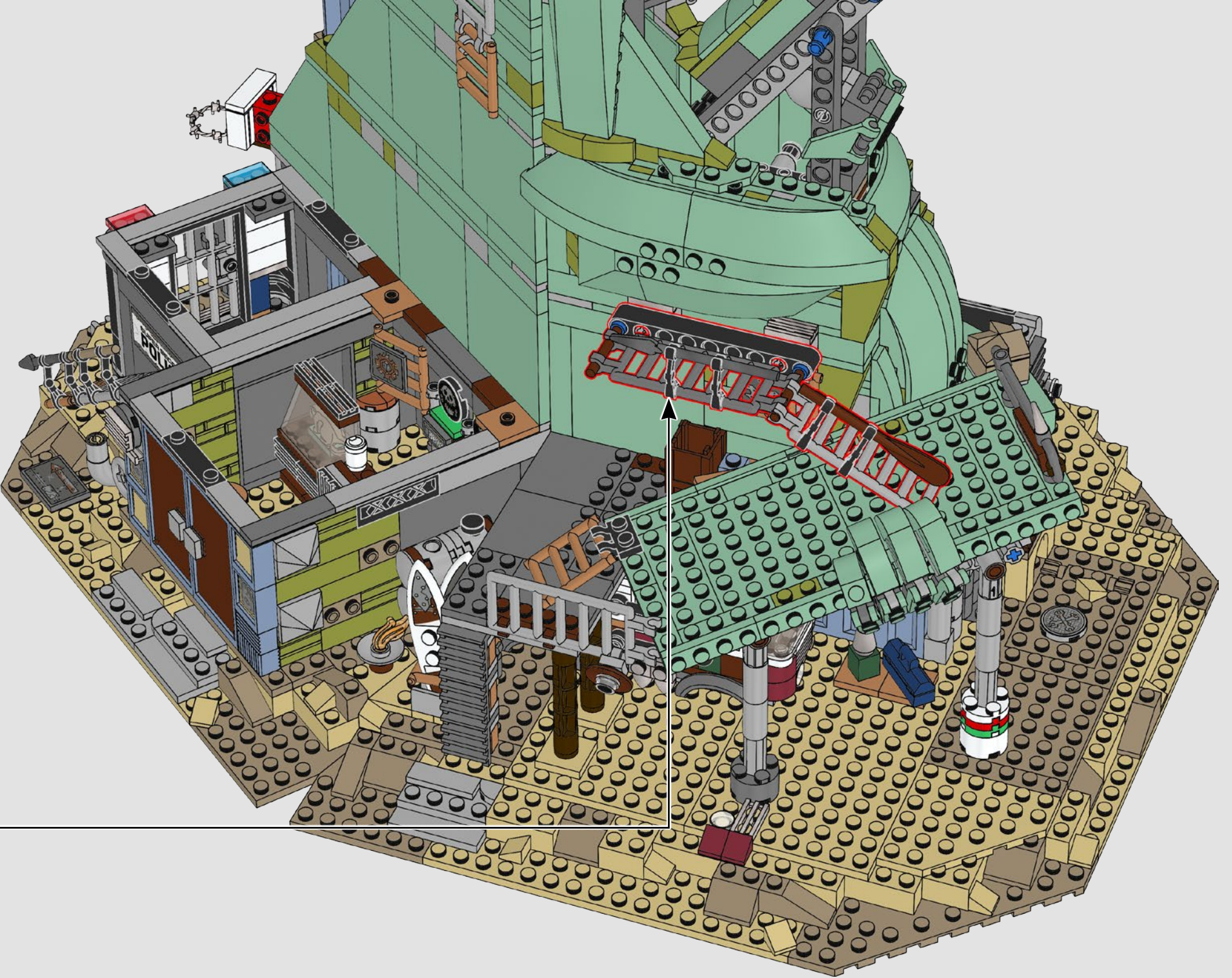

12

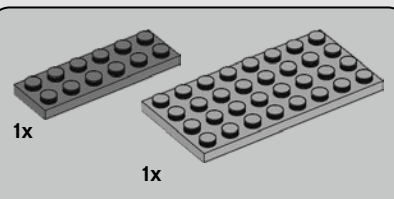
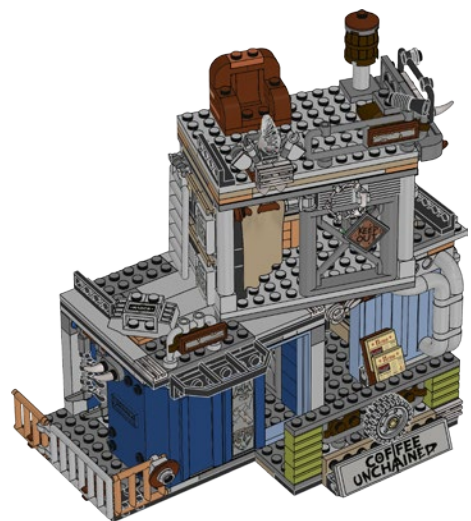
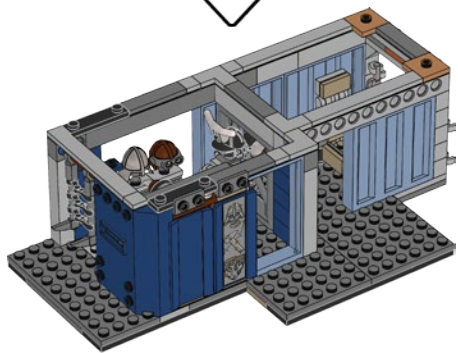

468

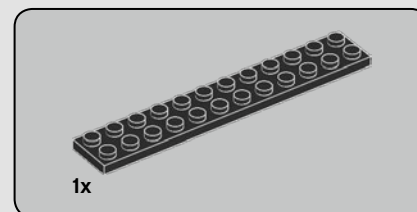
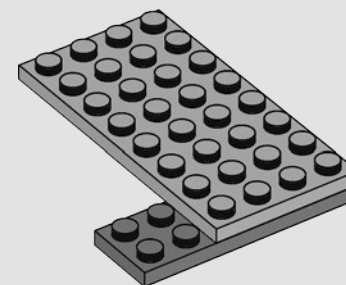

469

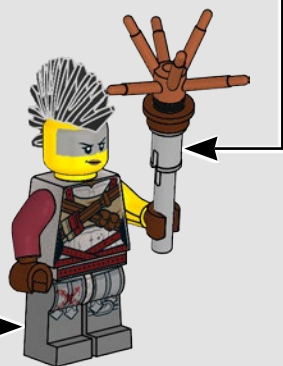
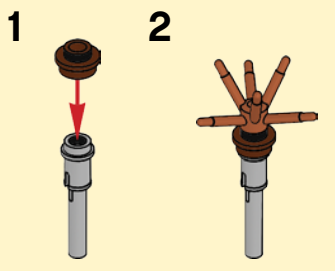
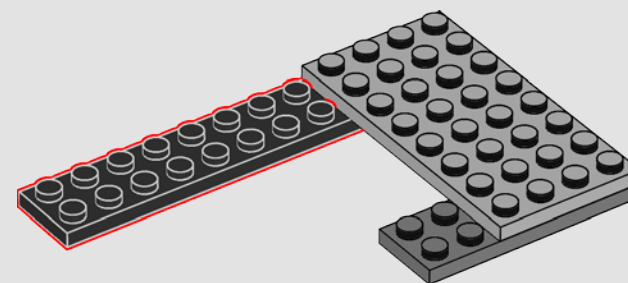



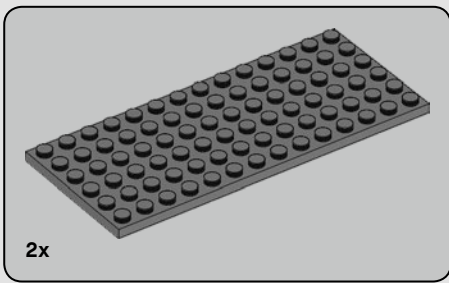

470

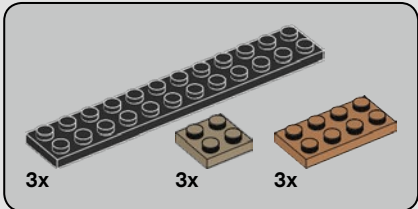
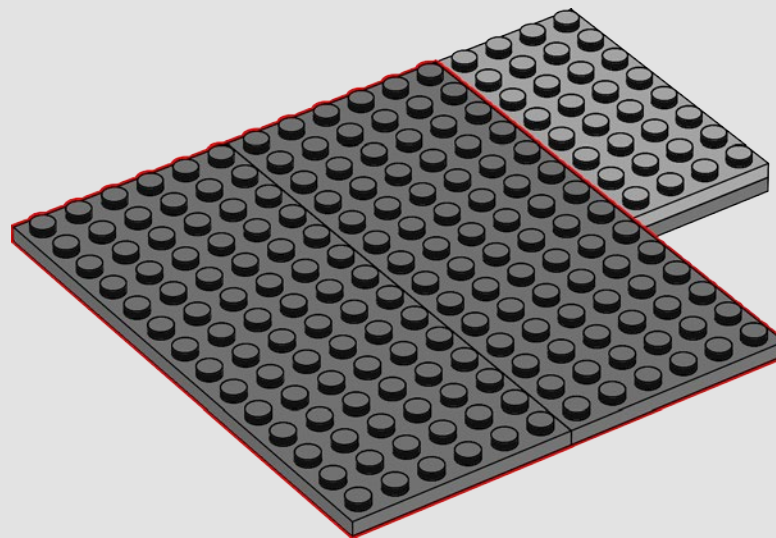

471

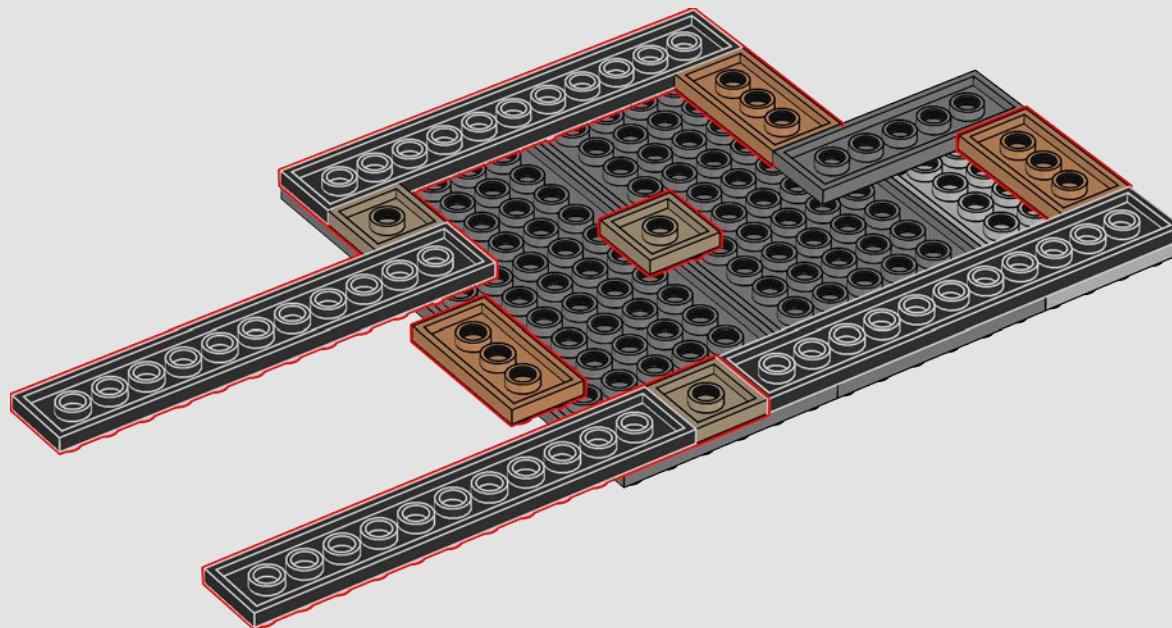
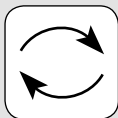

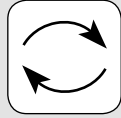
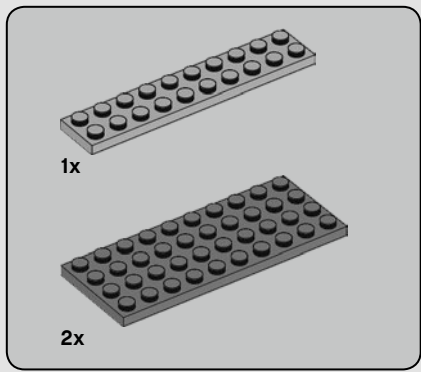

**472**

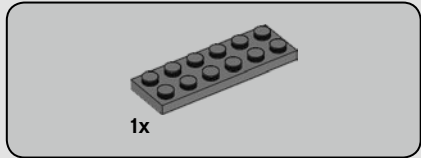
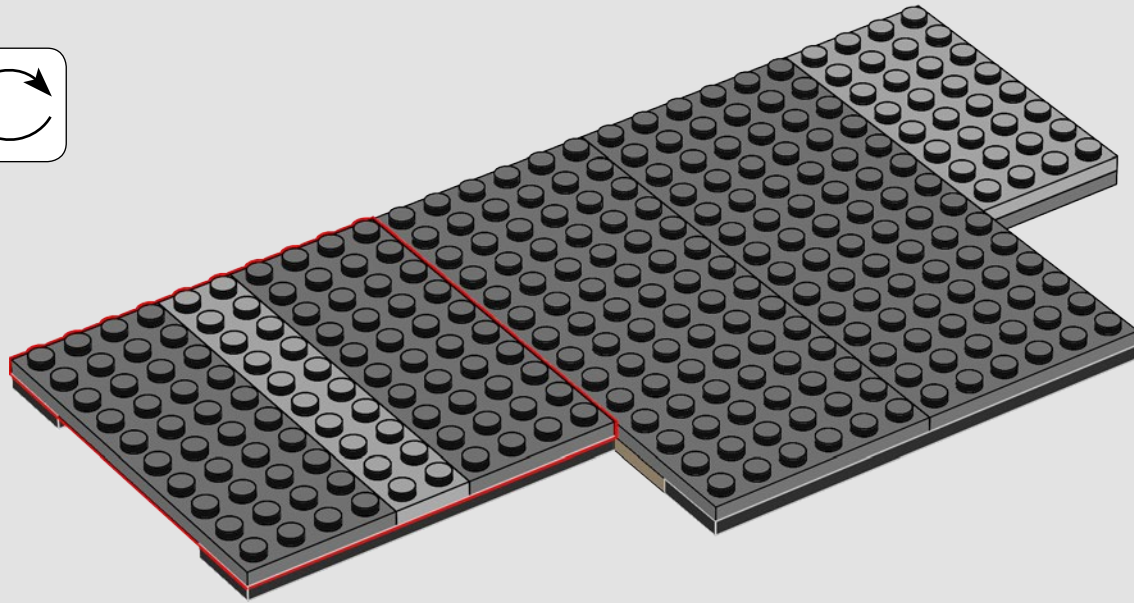

**473**

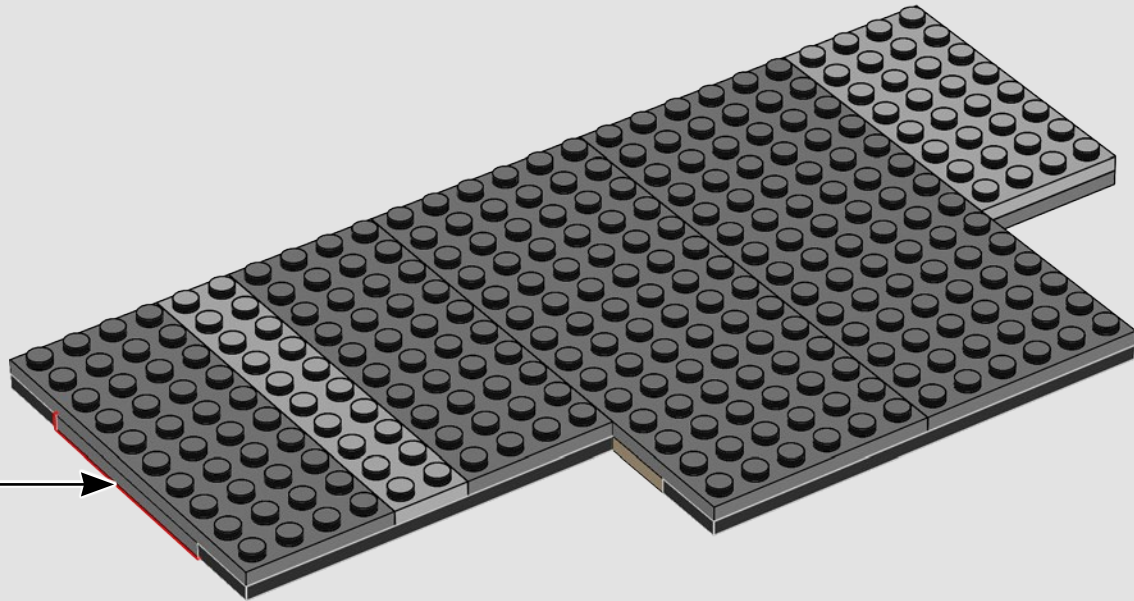
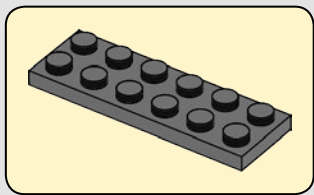

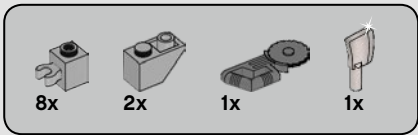

474

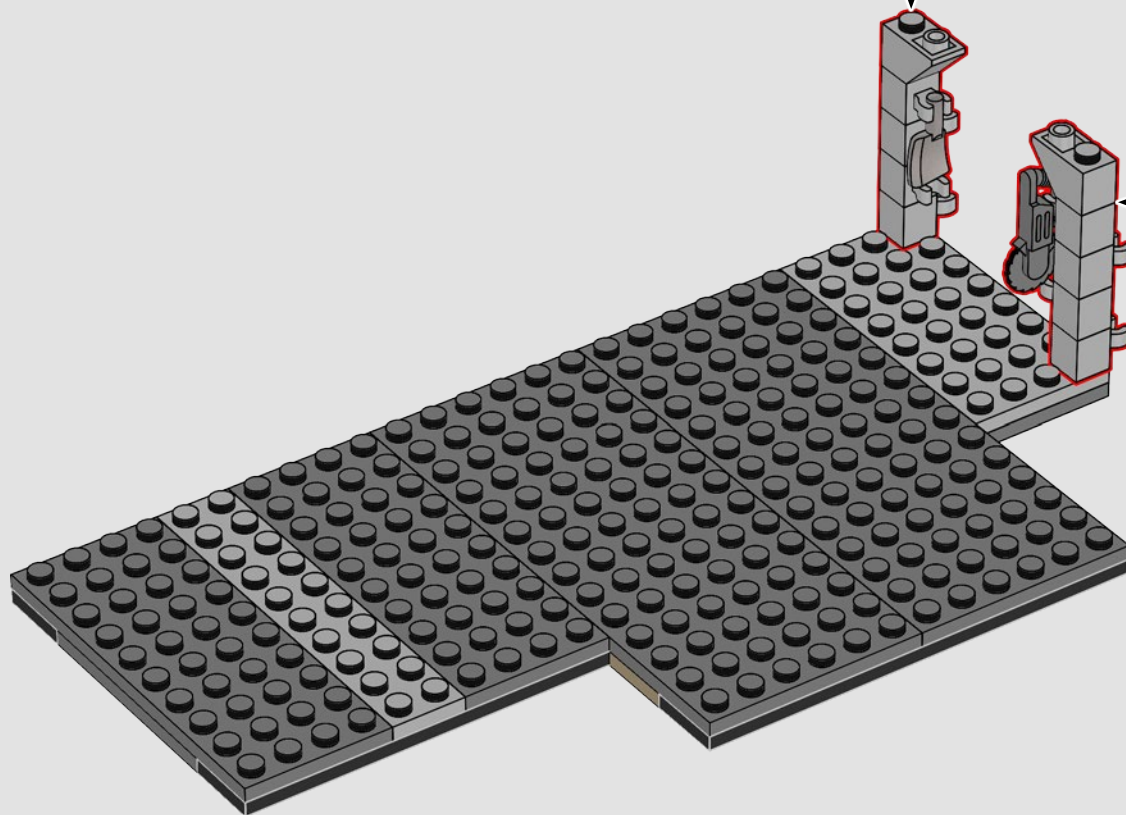
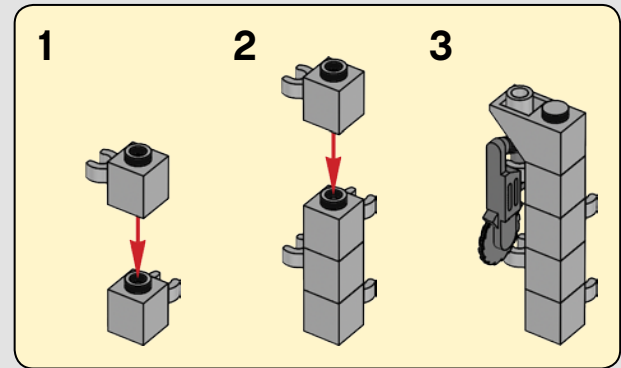
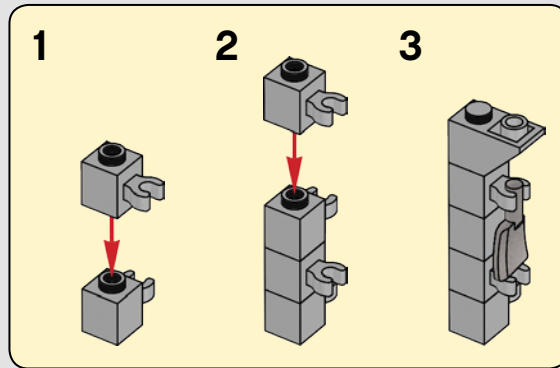

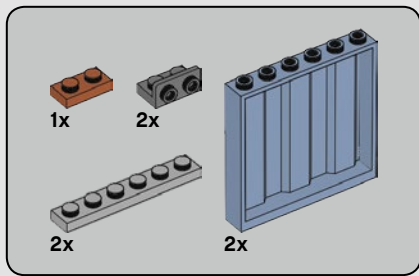

475

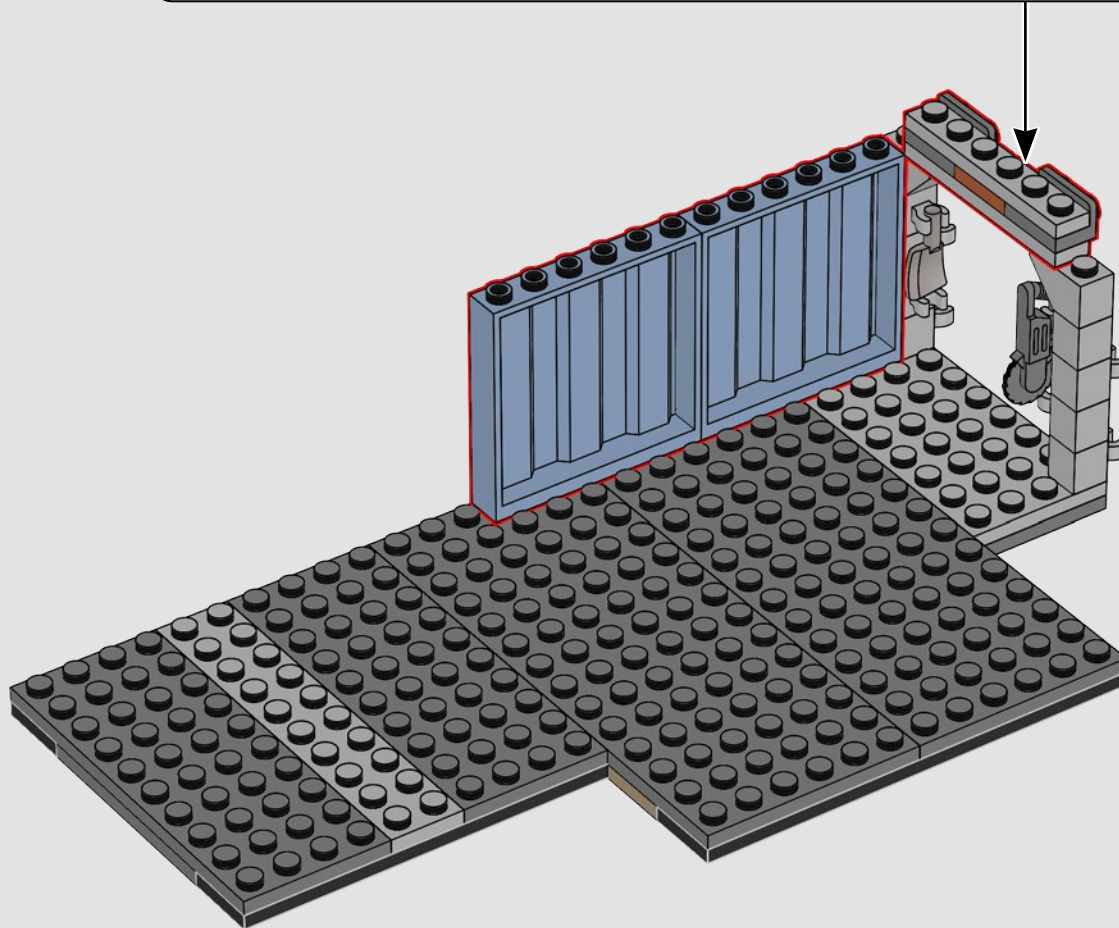
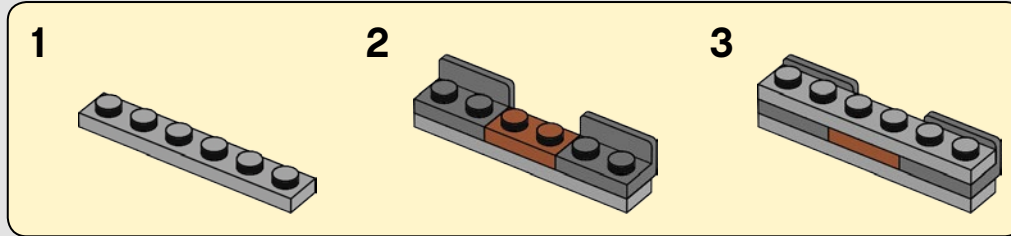

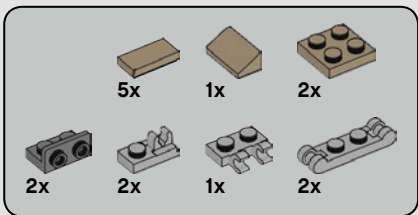

476

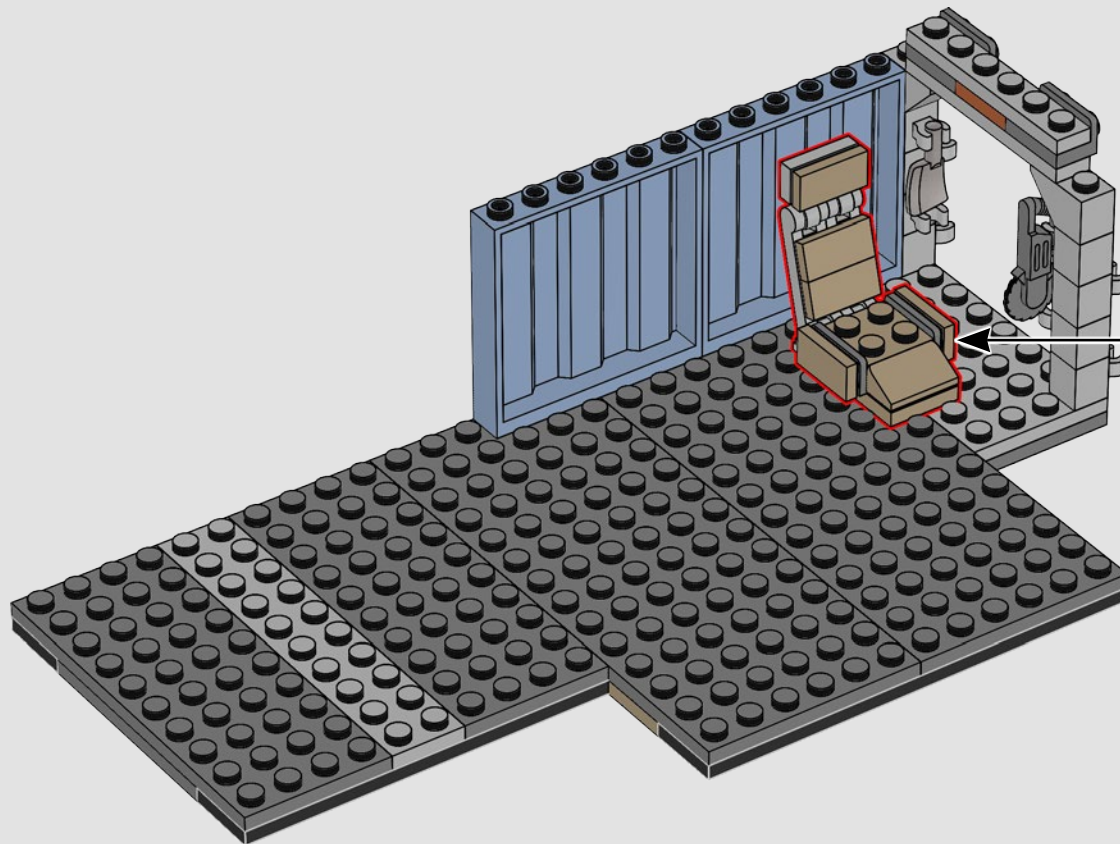
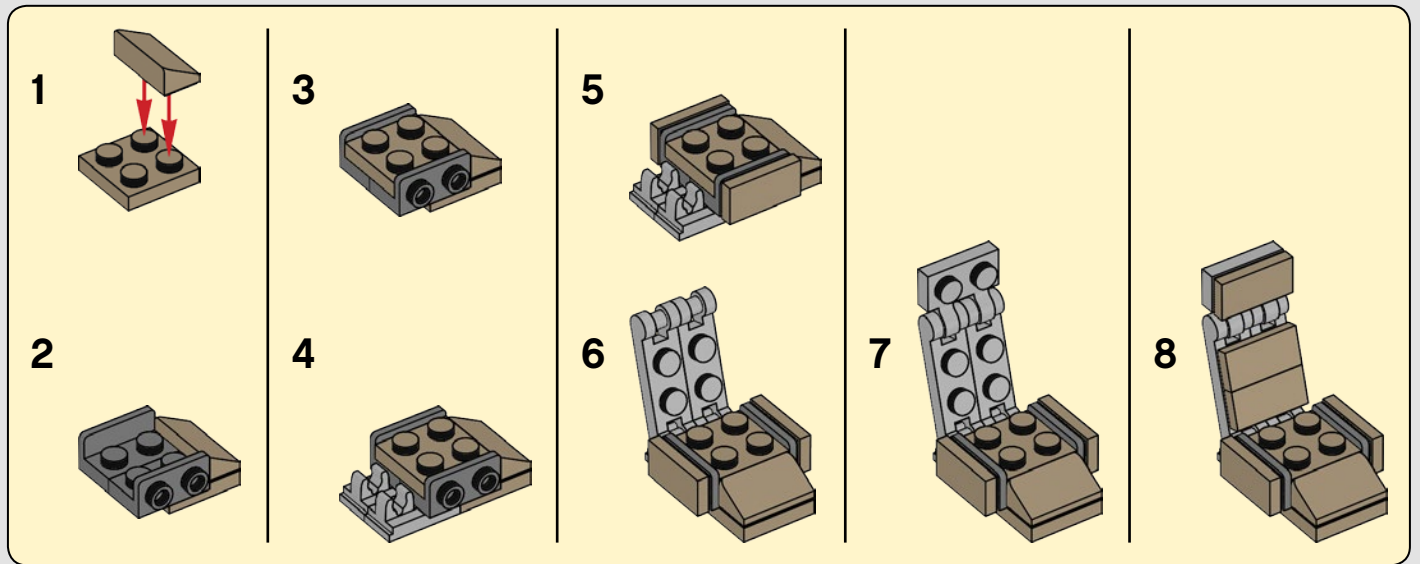

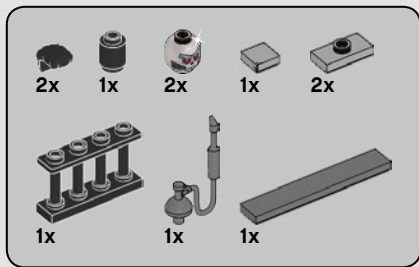

477

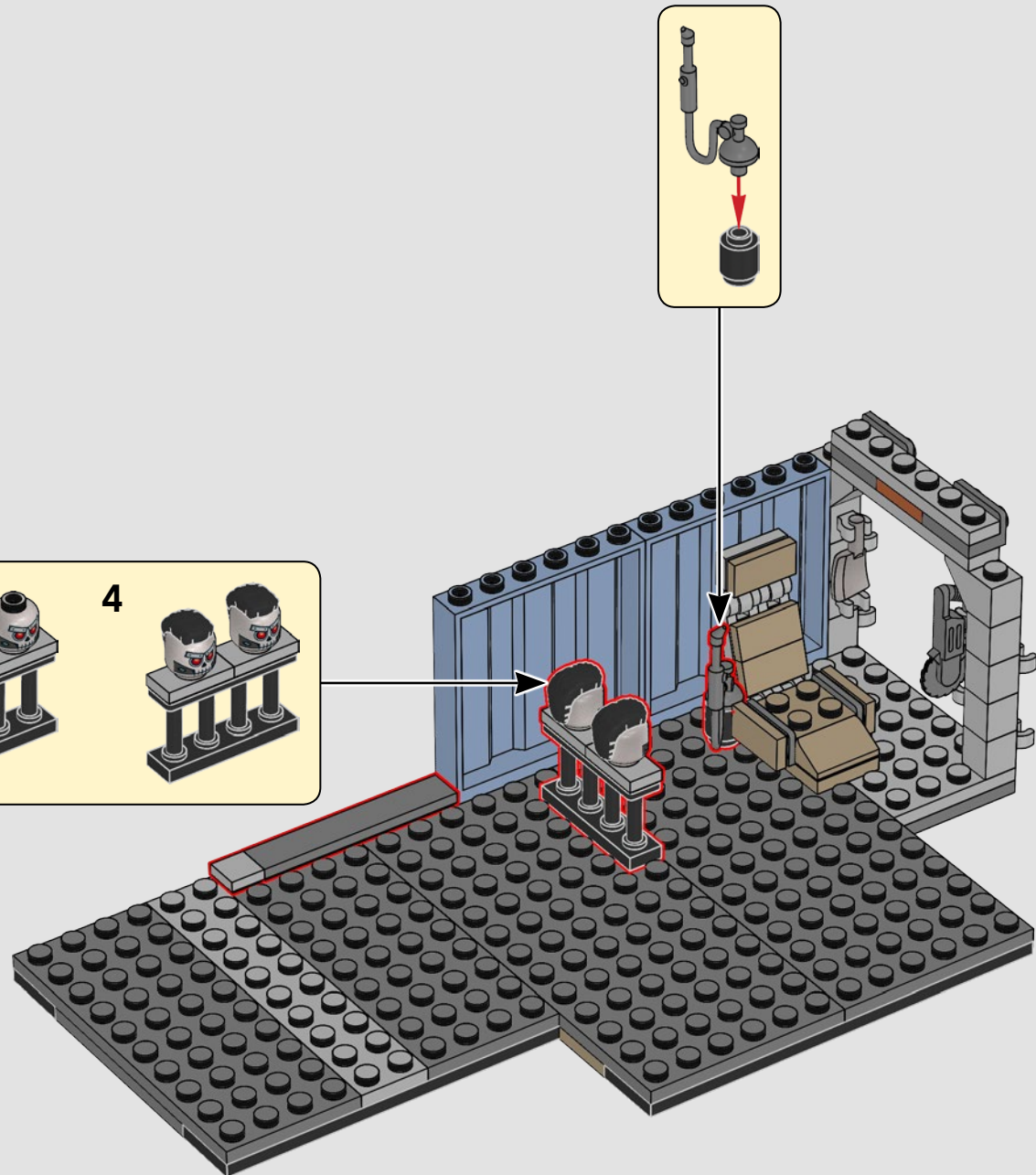
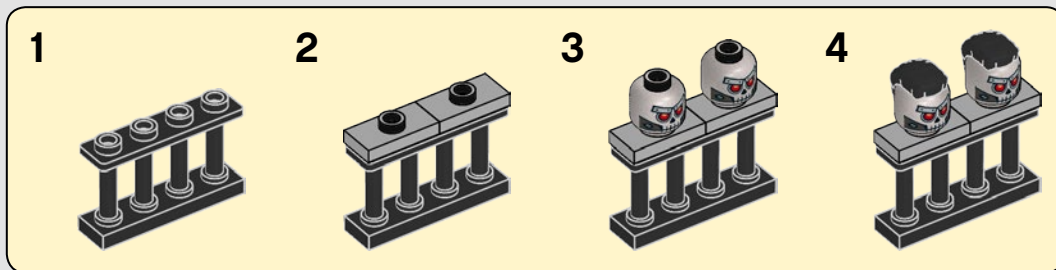

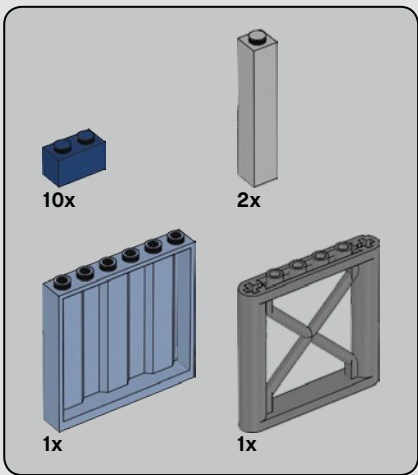

478

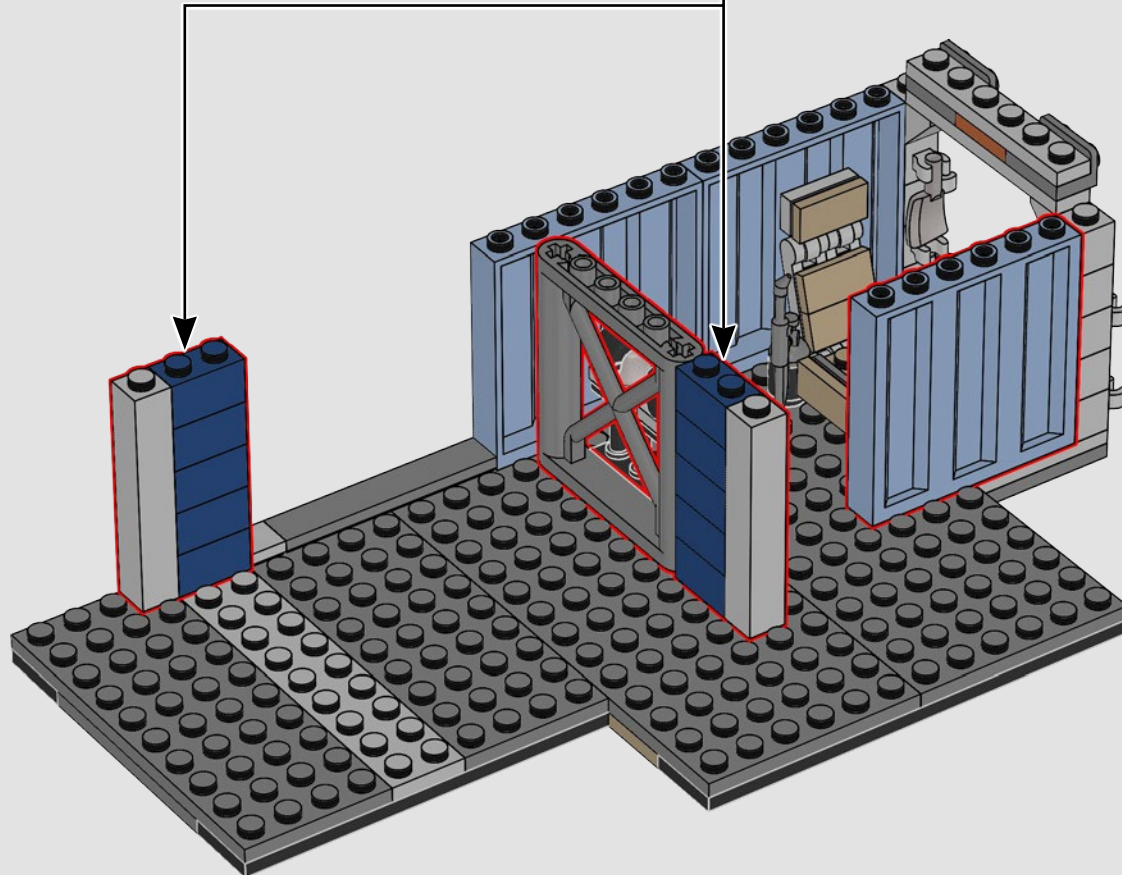
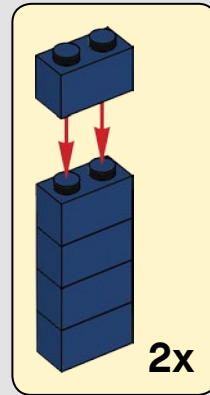

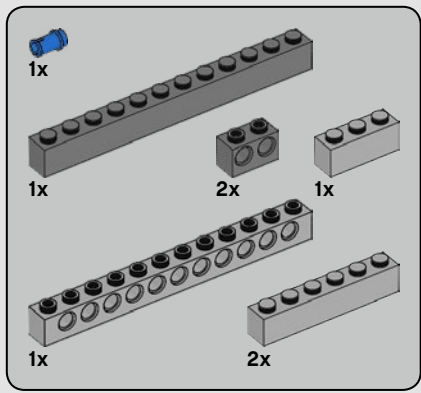

479

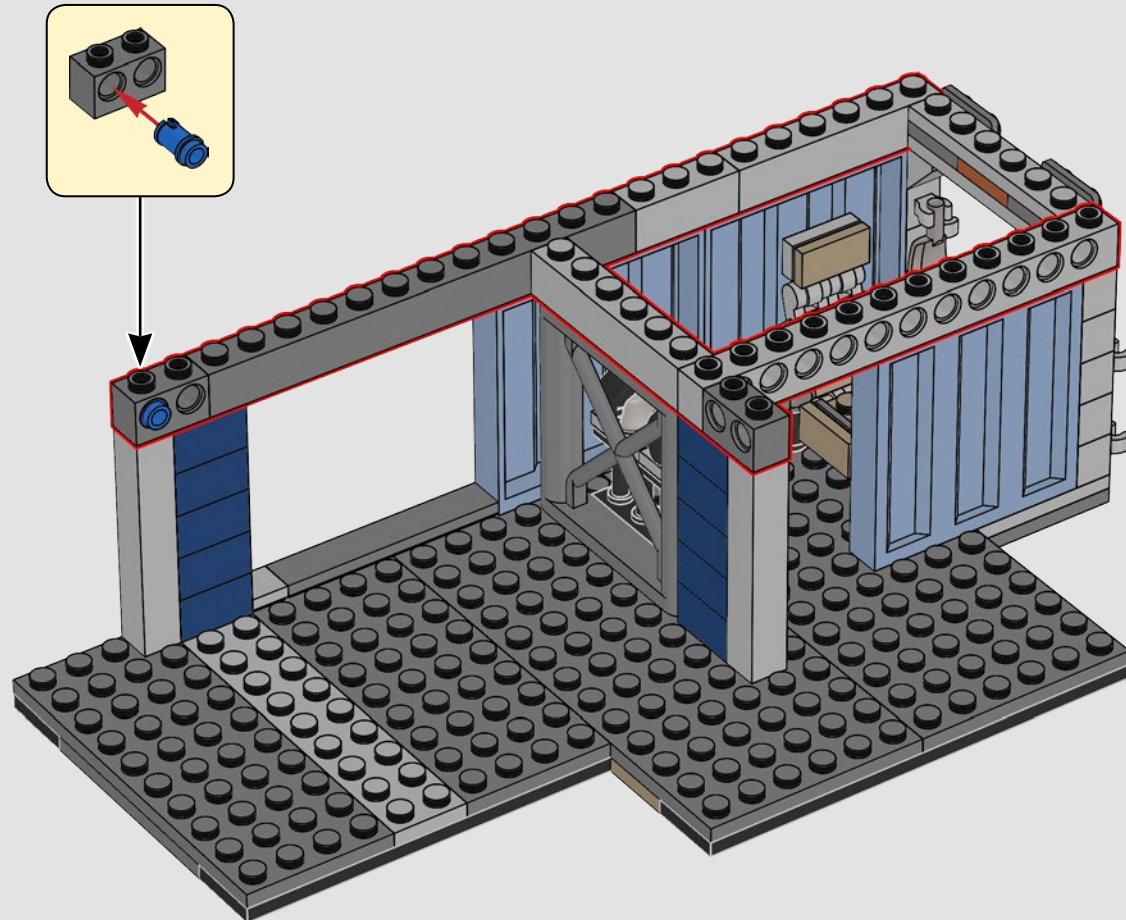



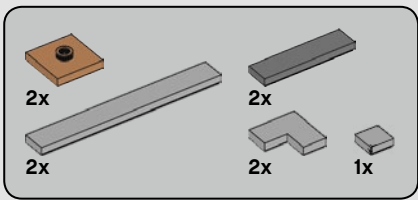

480

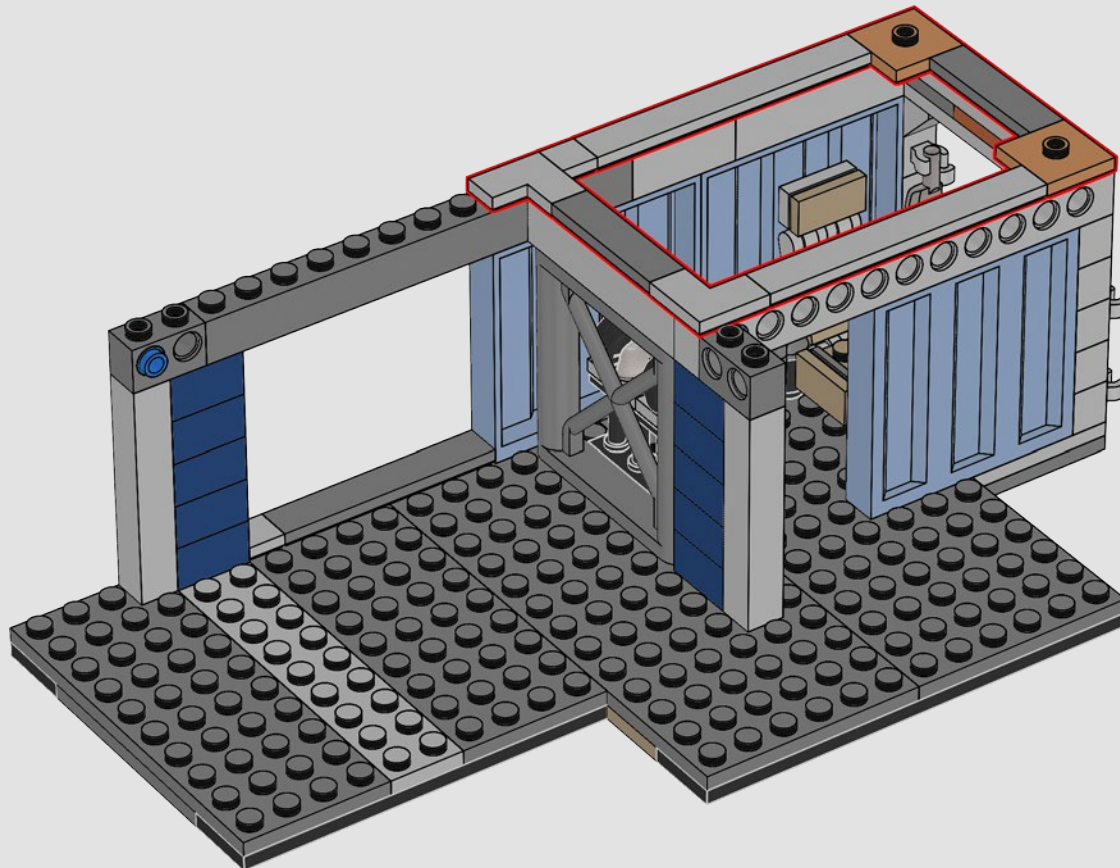

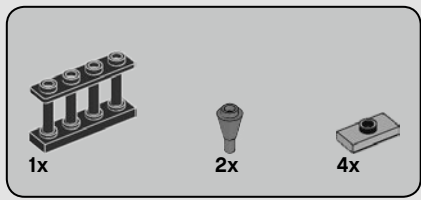

481

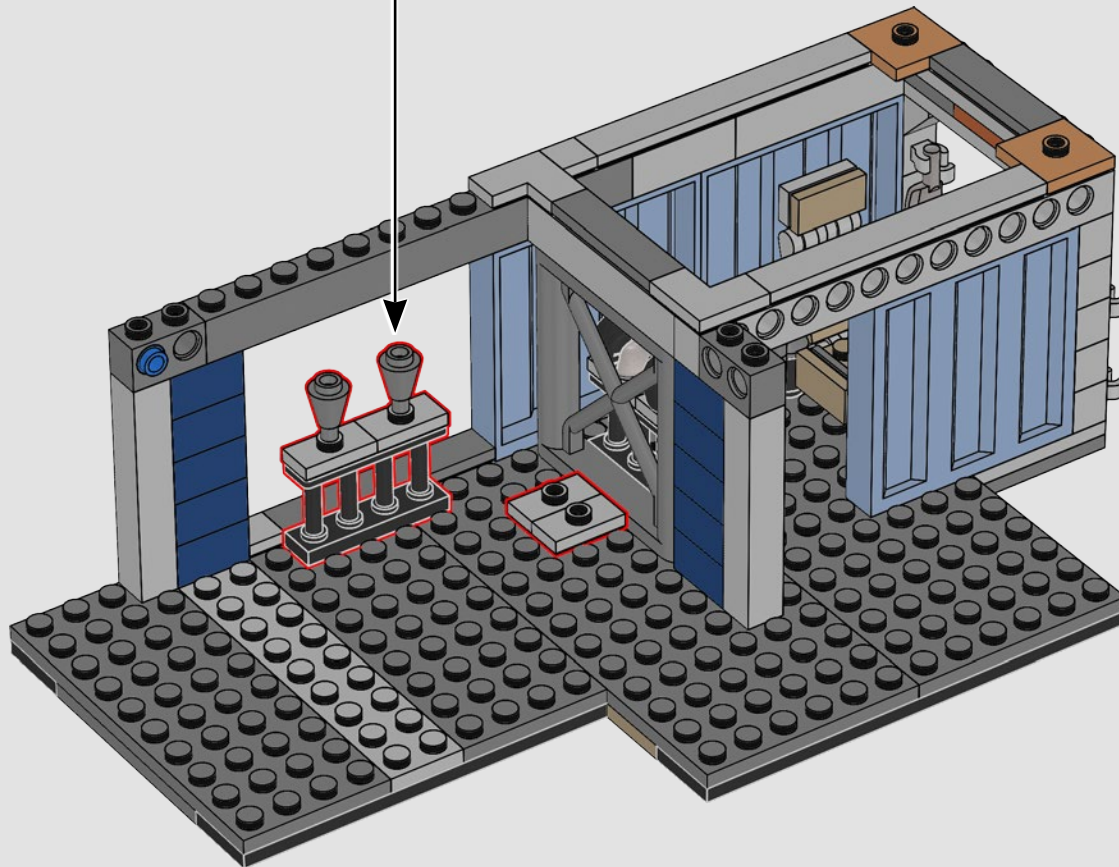
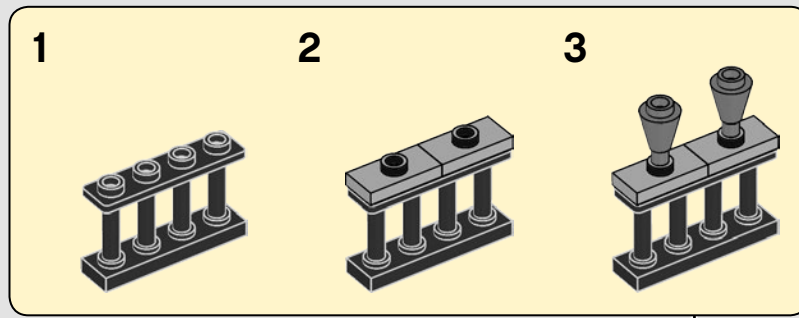

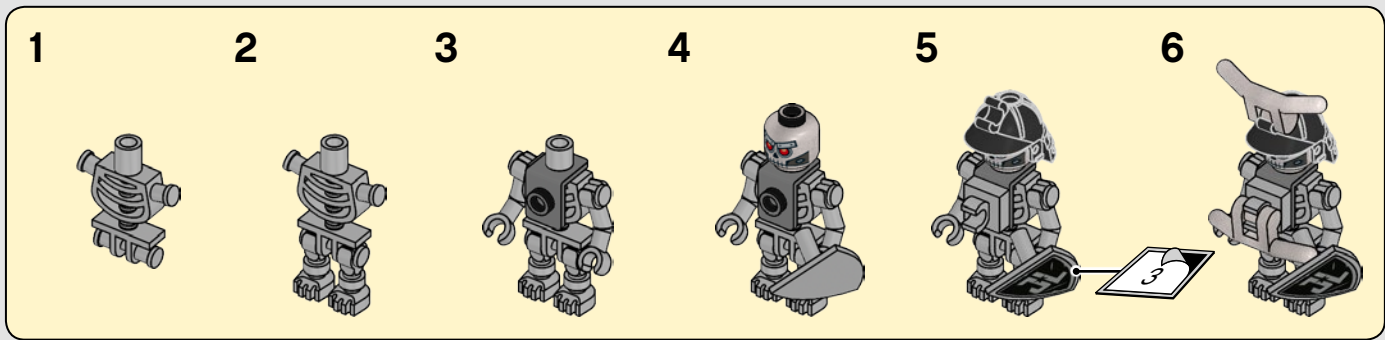
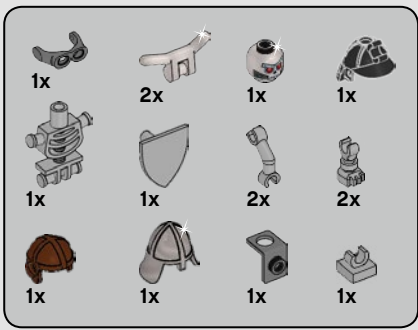

482

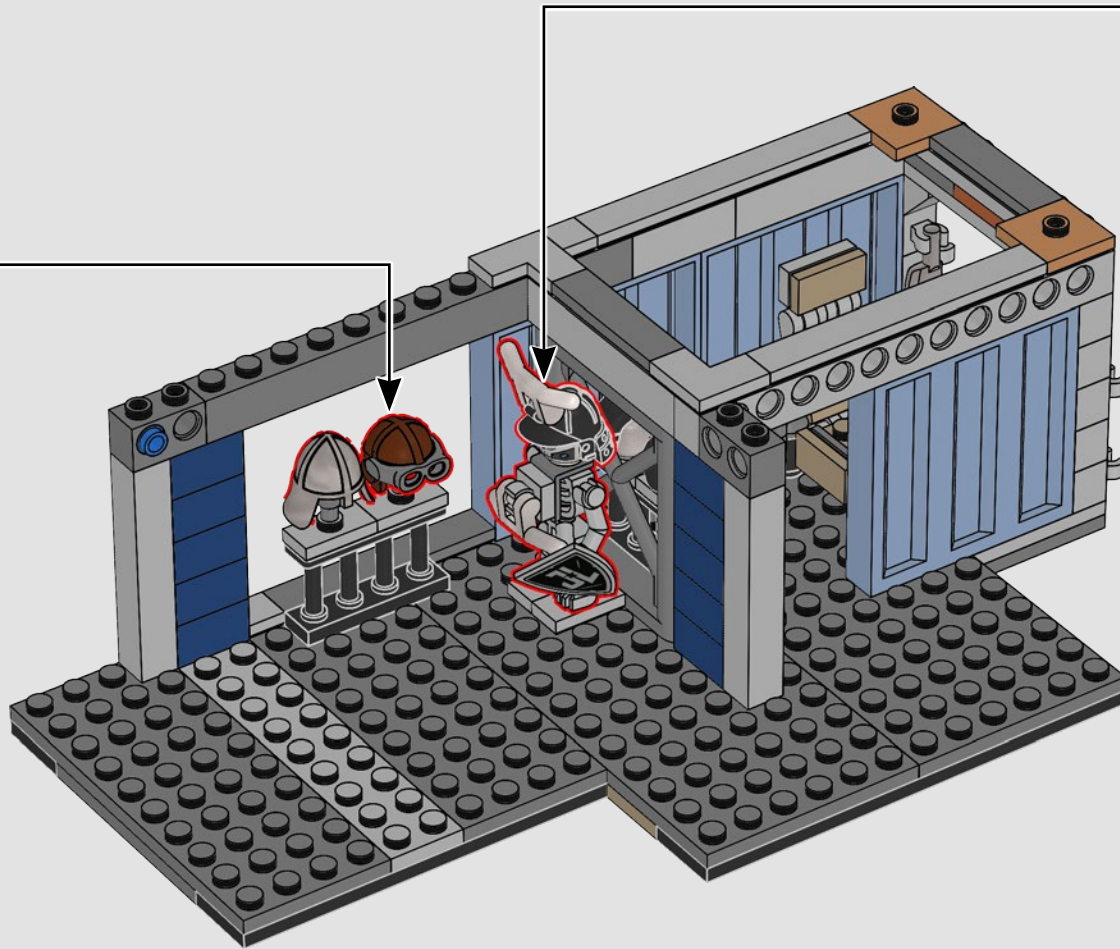
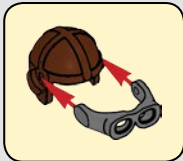



483

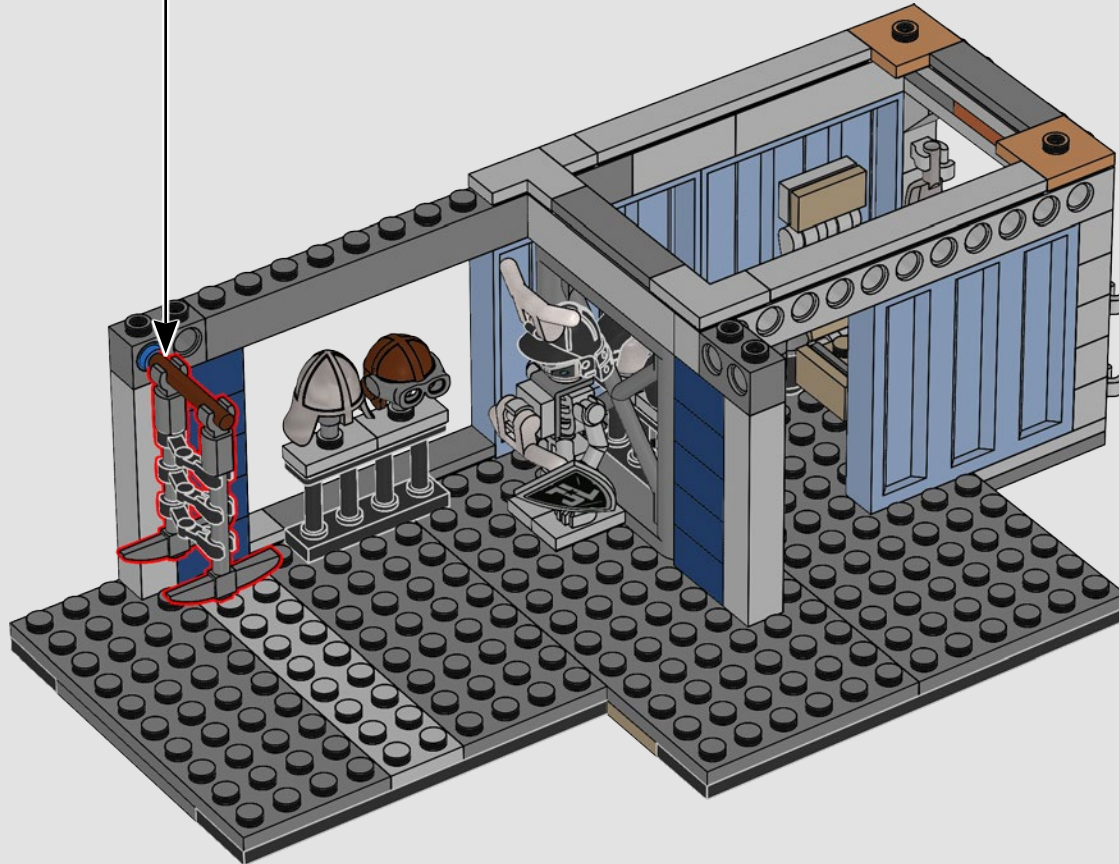
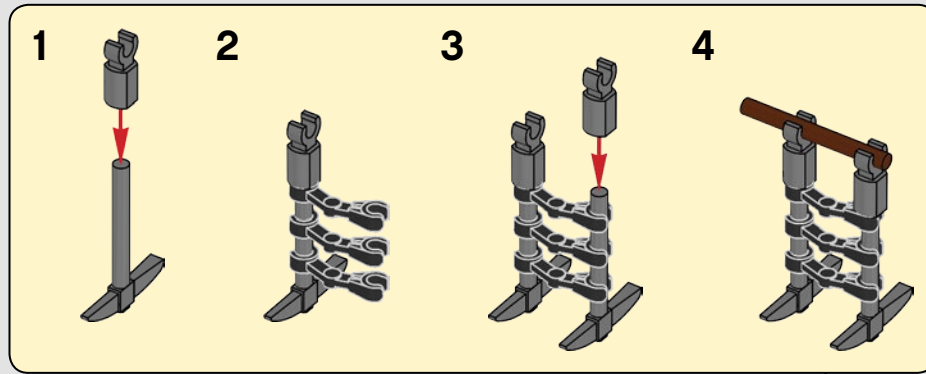

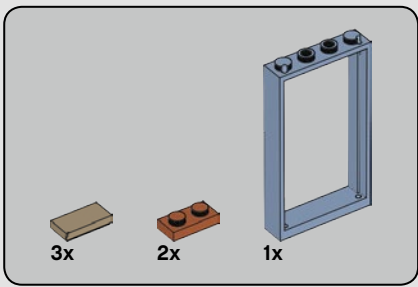

484

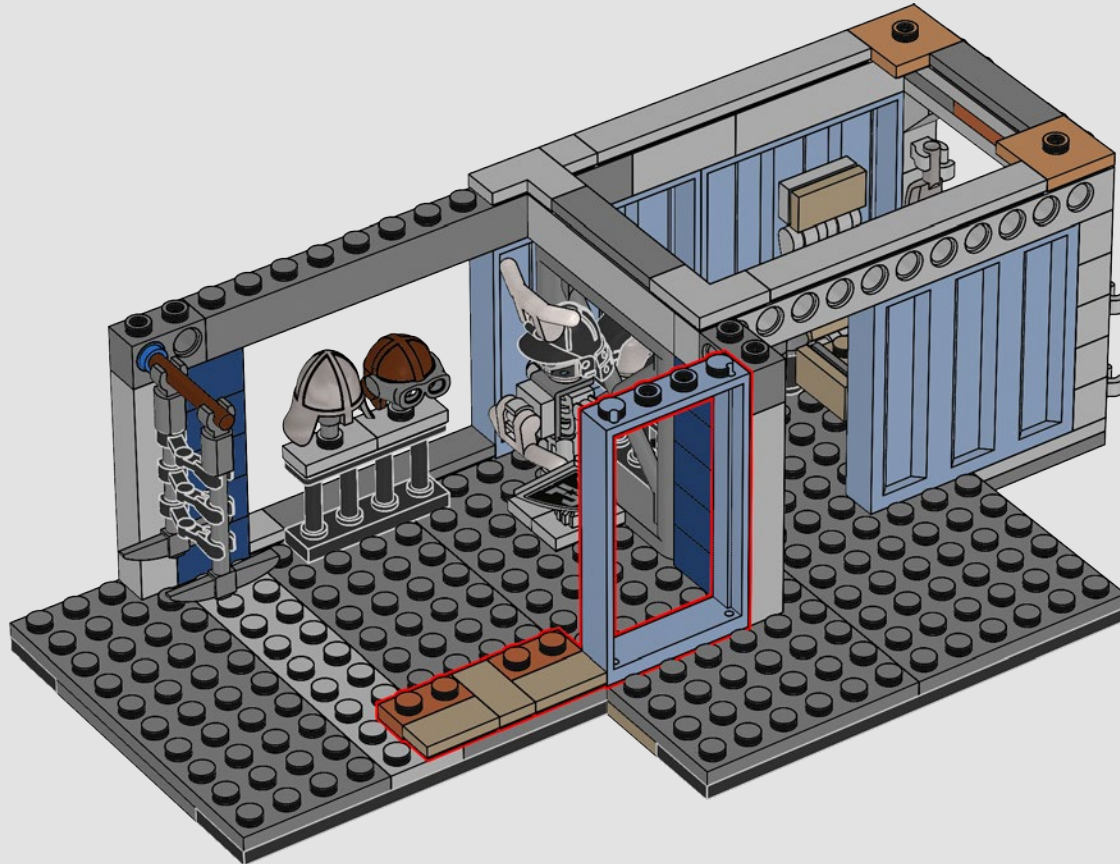

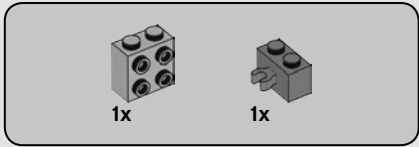
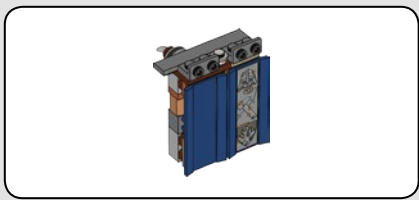

485

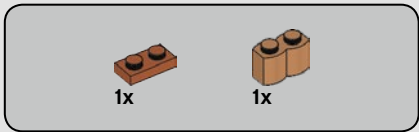
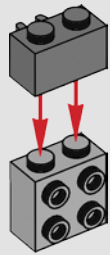

486

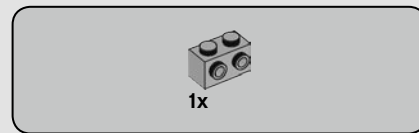
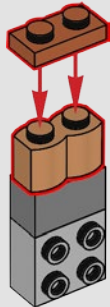

487



488

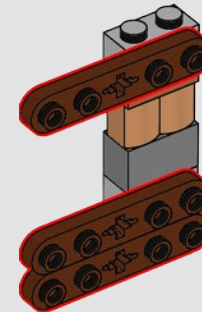

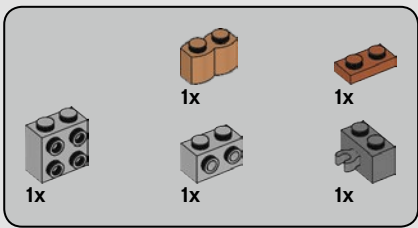

489

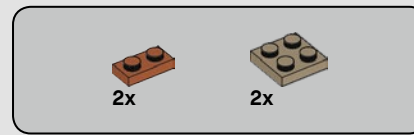
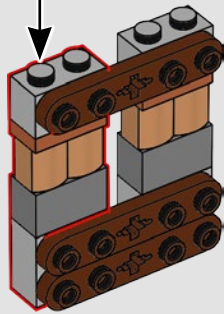
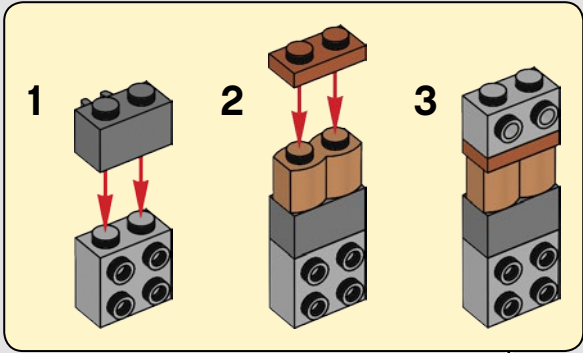

490

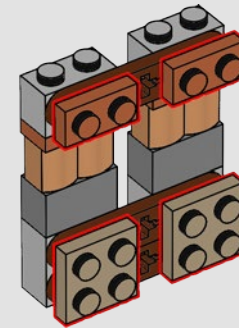

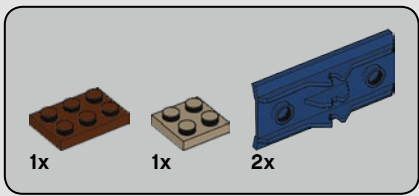

491

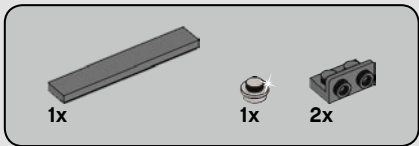
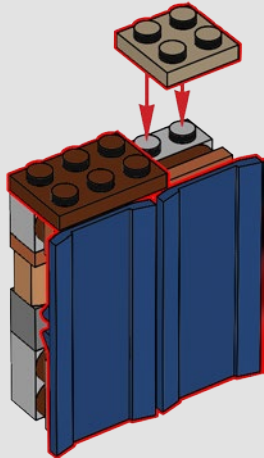

492

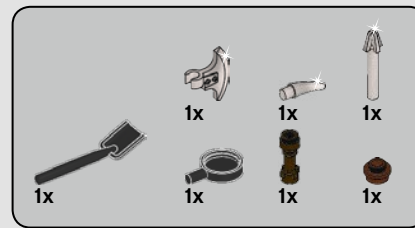
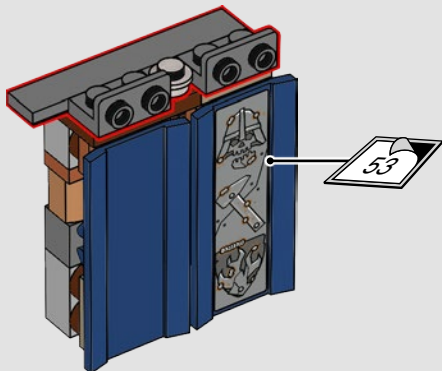

493

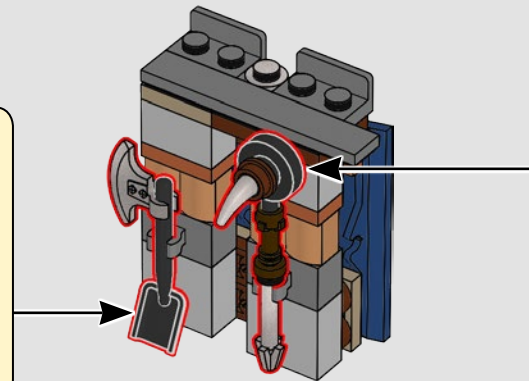
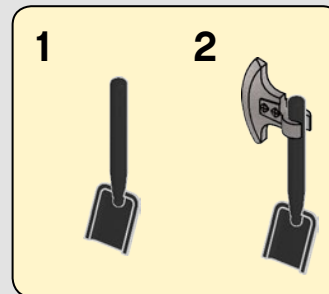
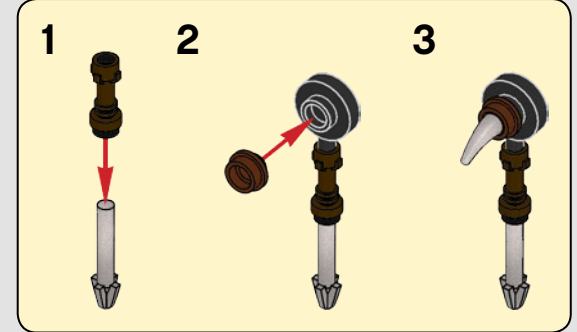



494

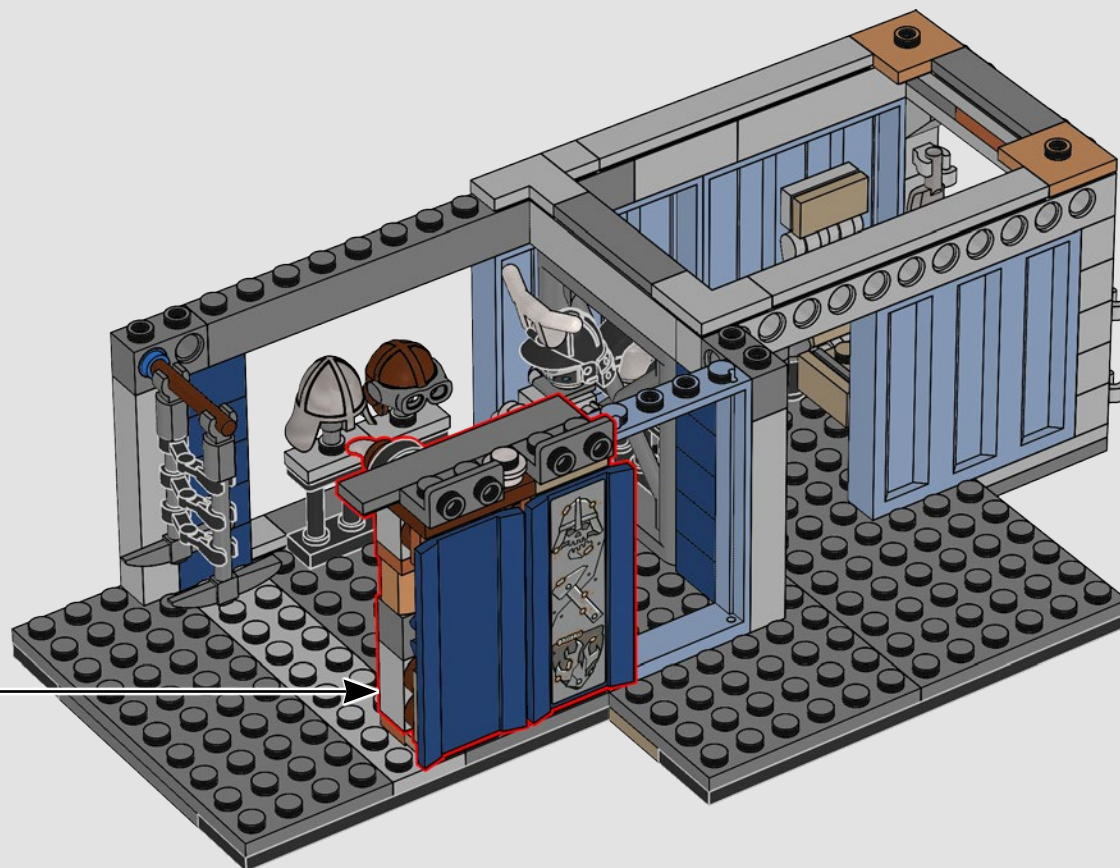

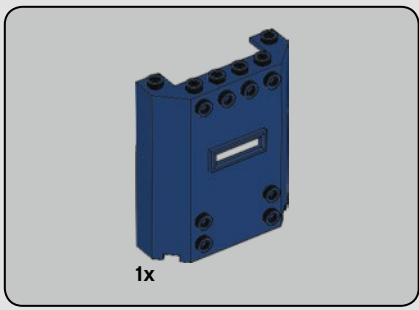

495

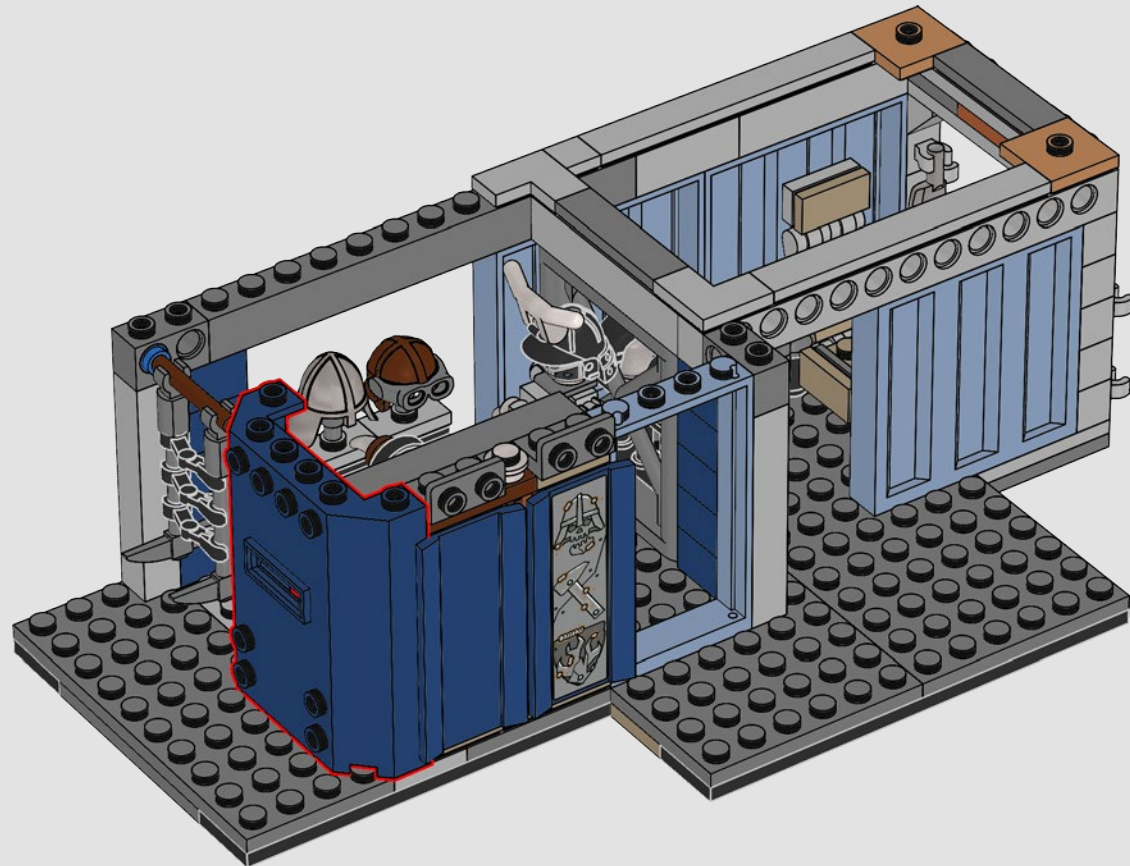

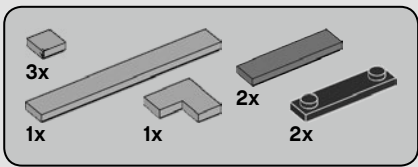

496

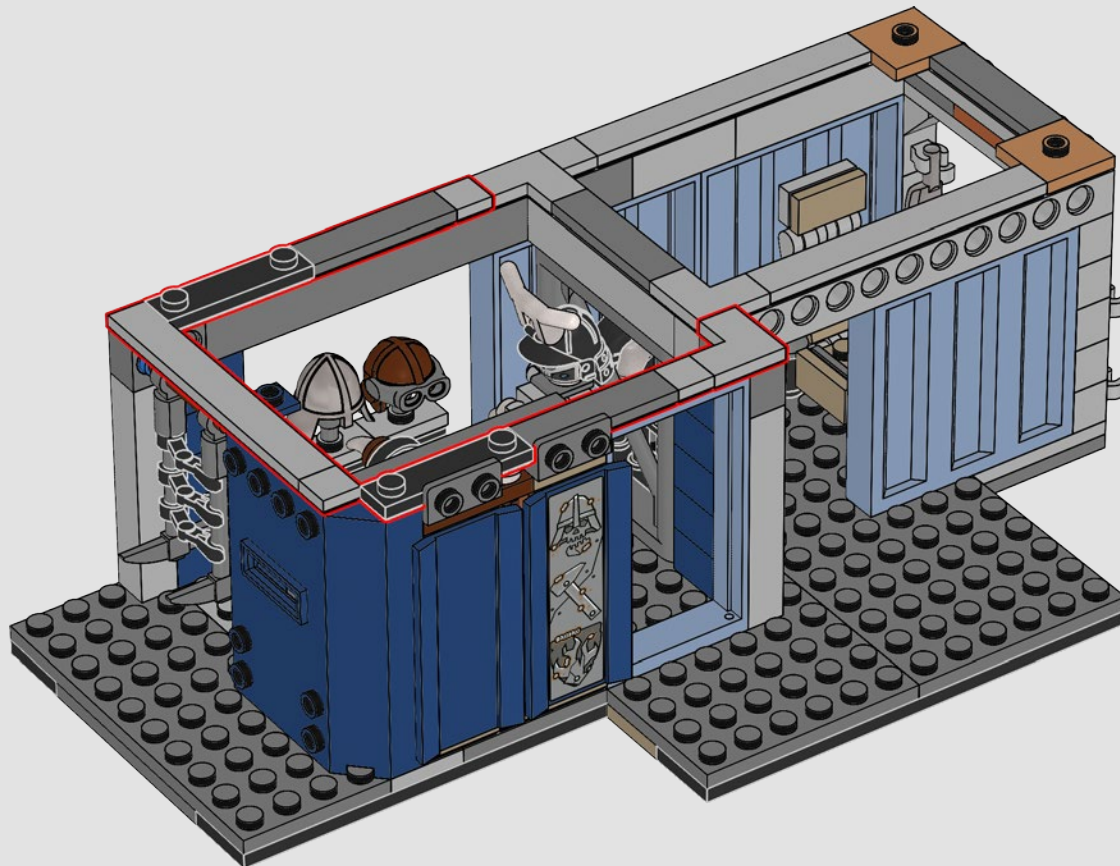

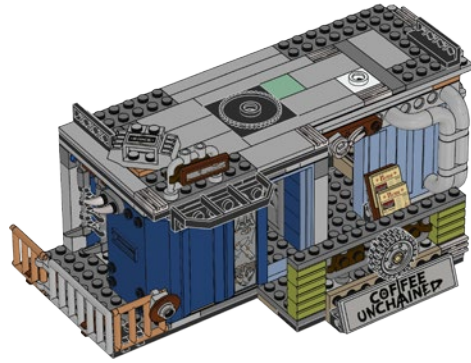
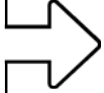

1x



2x



1x

497

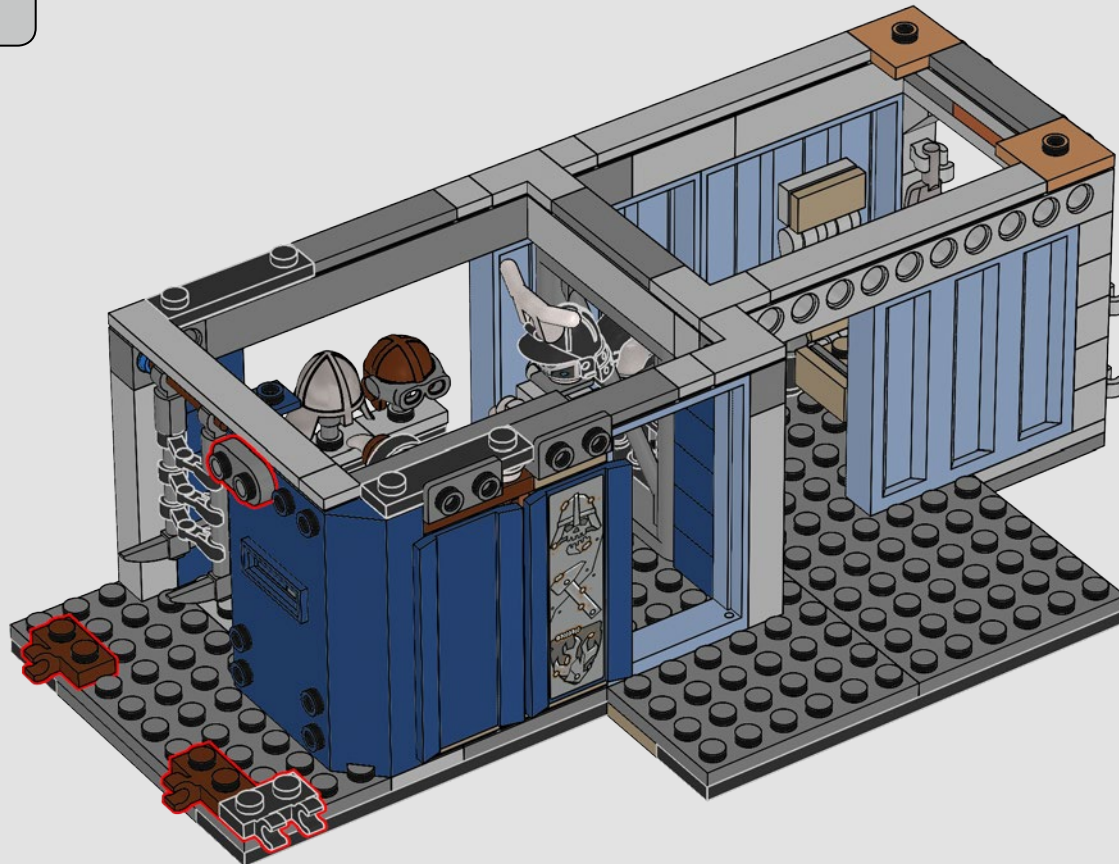

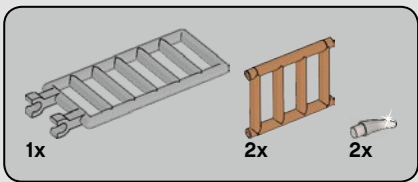

498

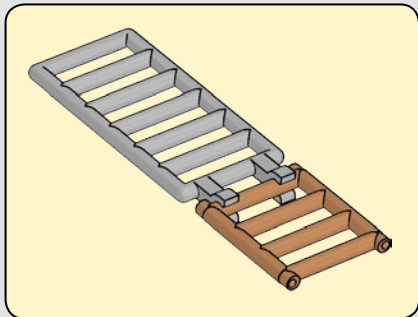
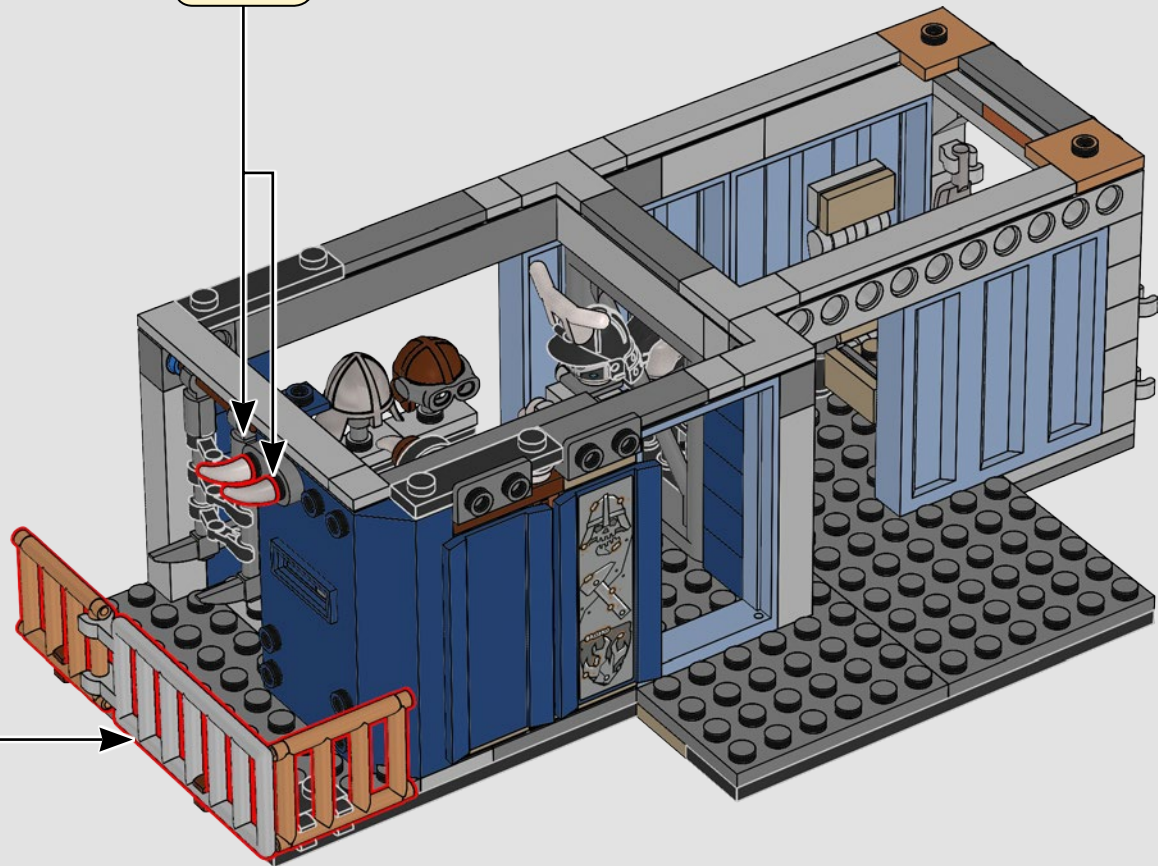

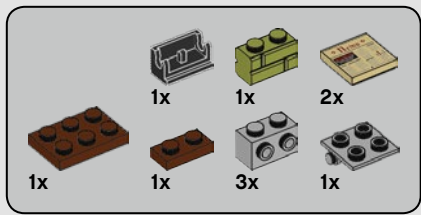

499

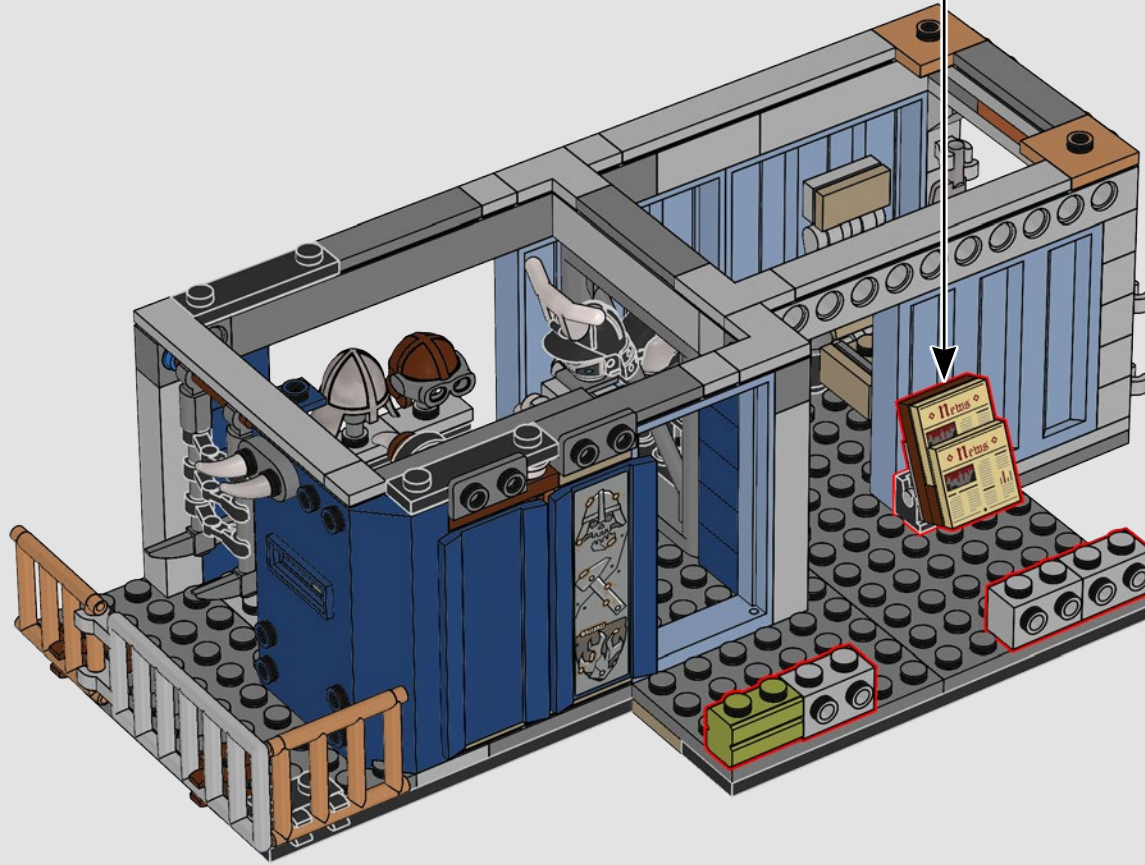
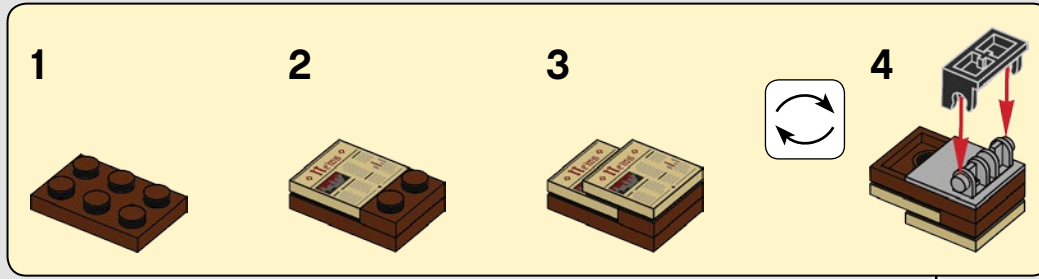

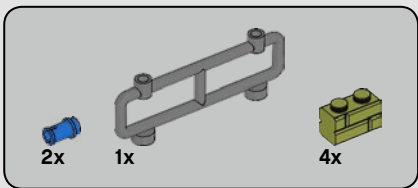

500

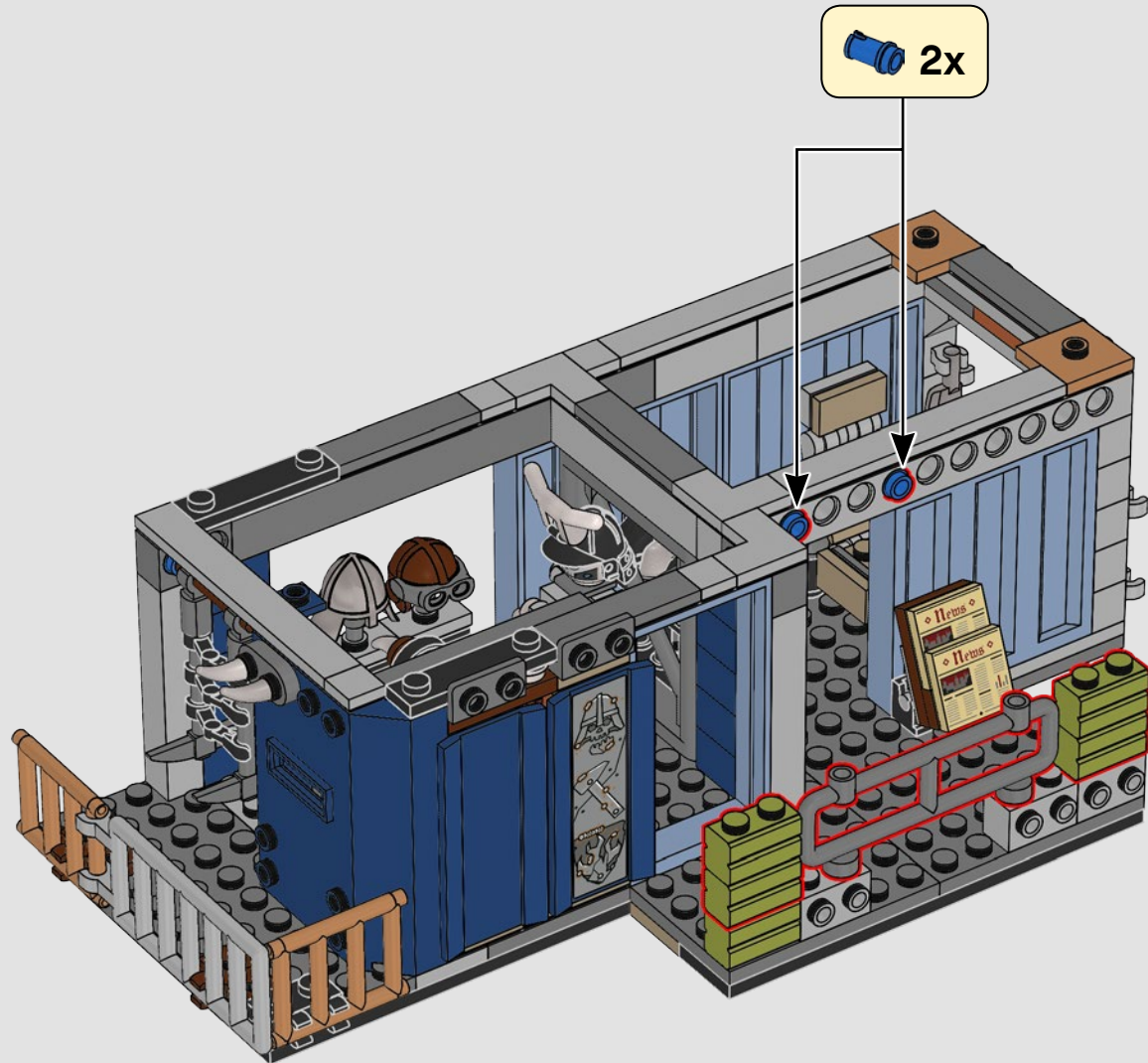

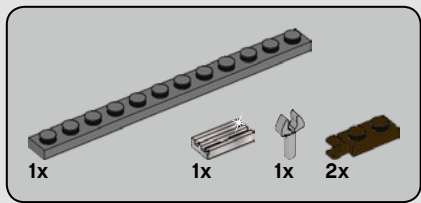

501

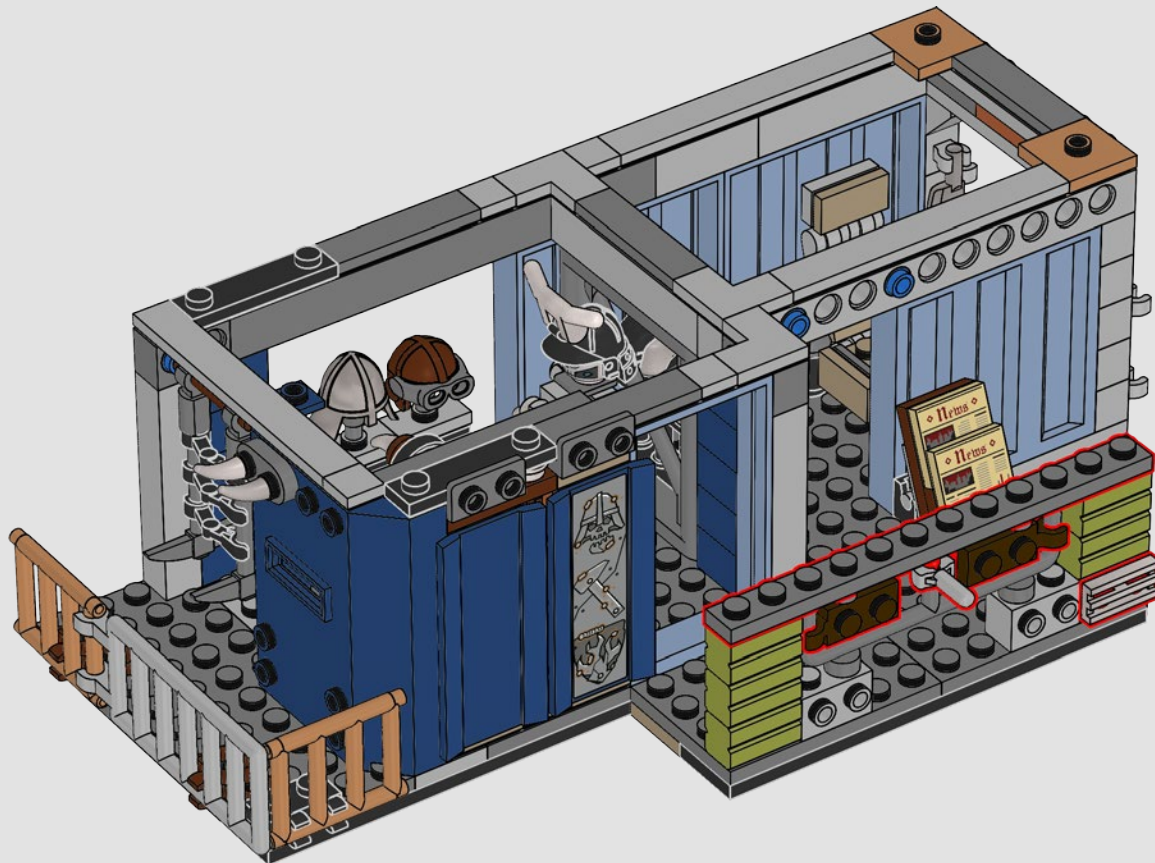



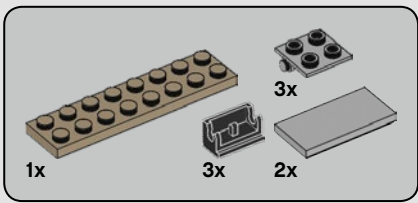

502

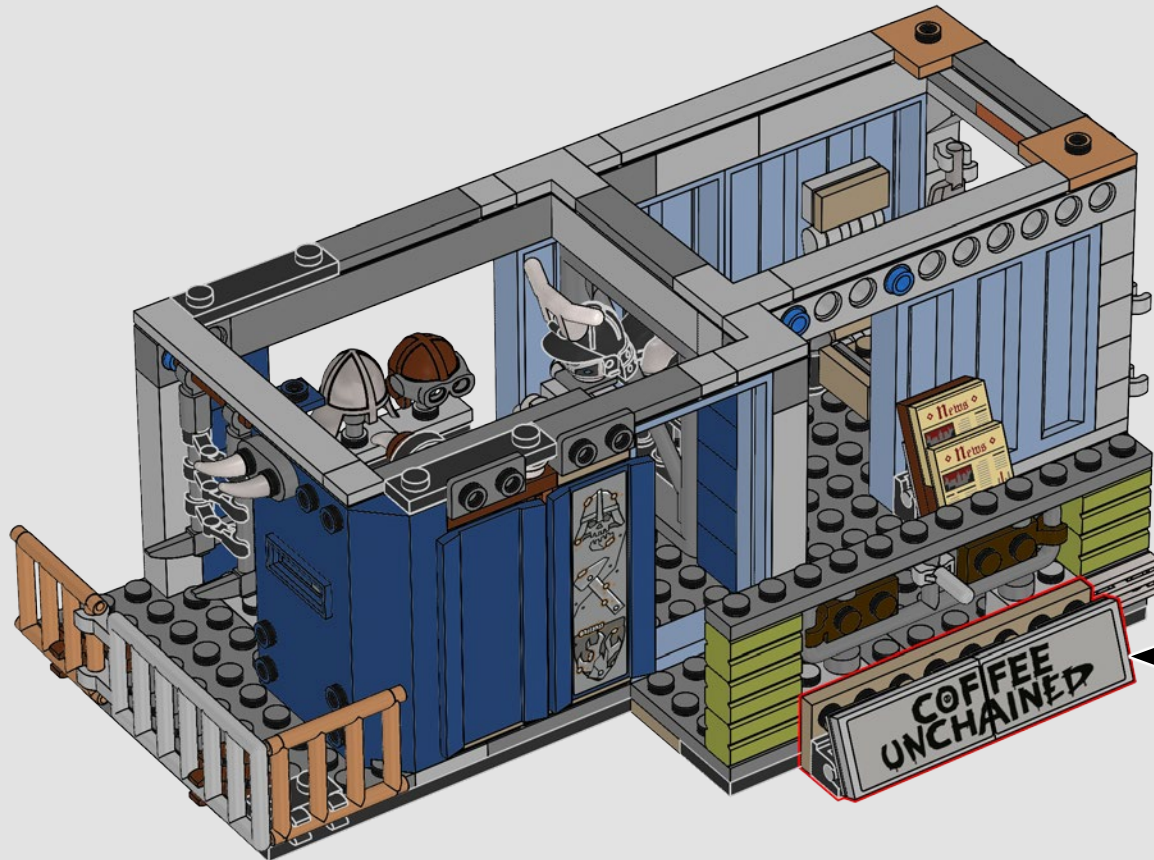
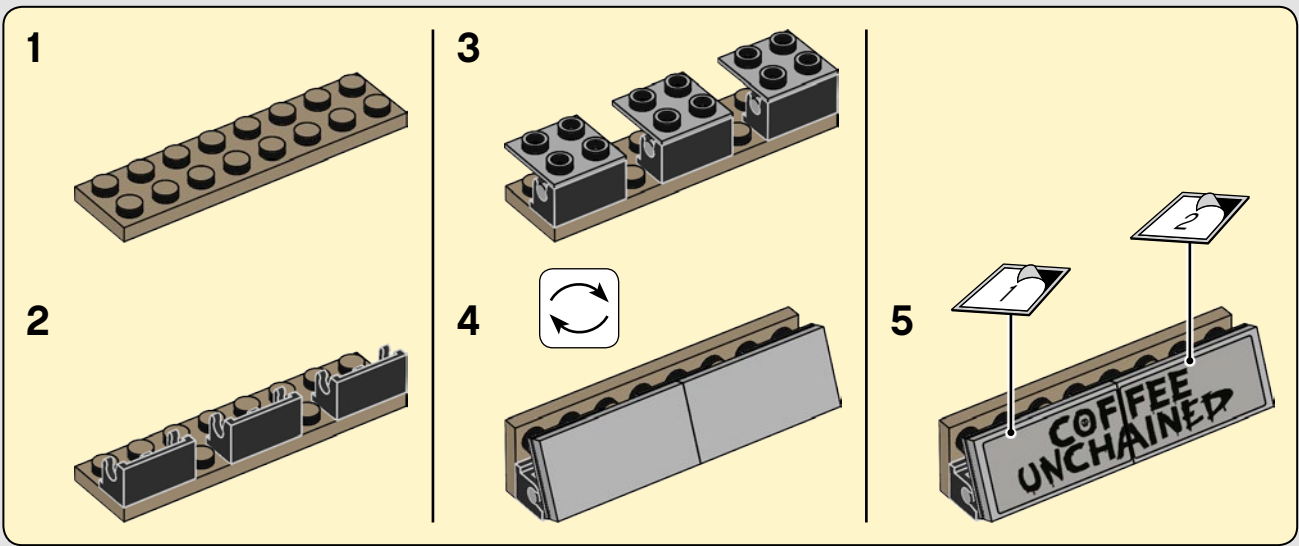

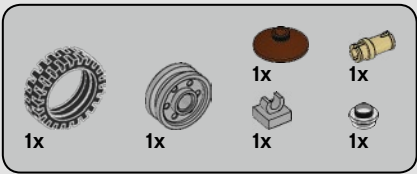

# 503

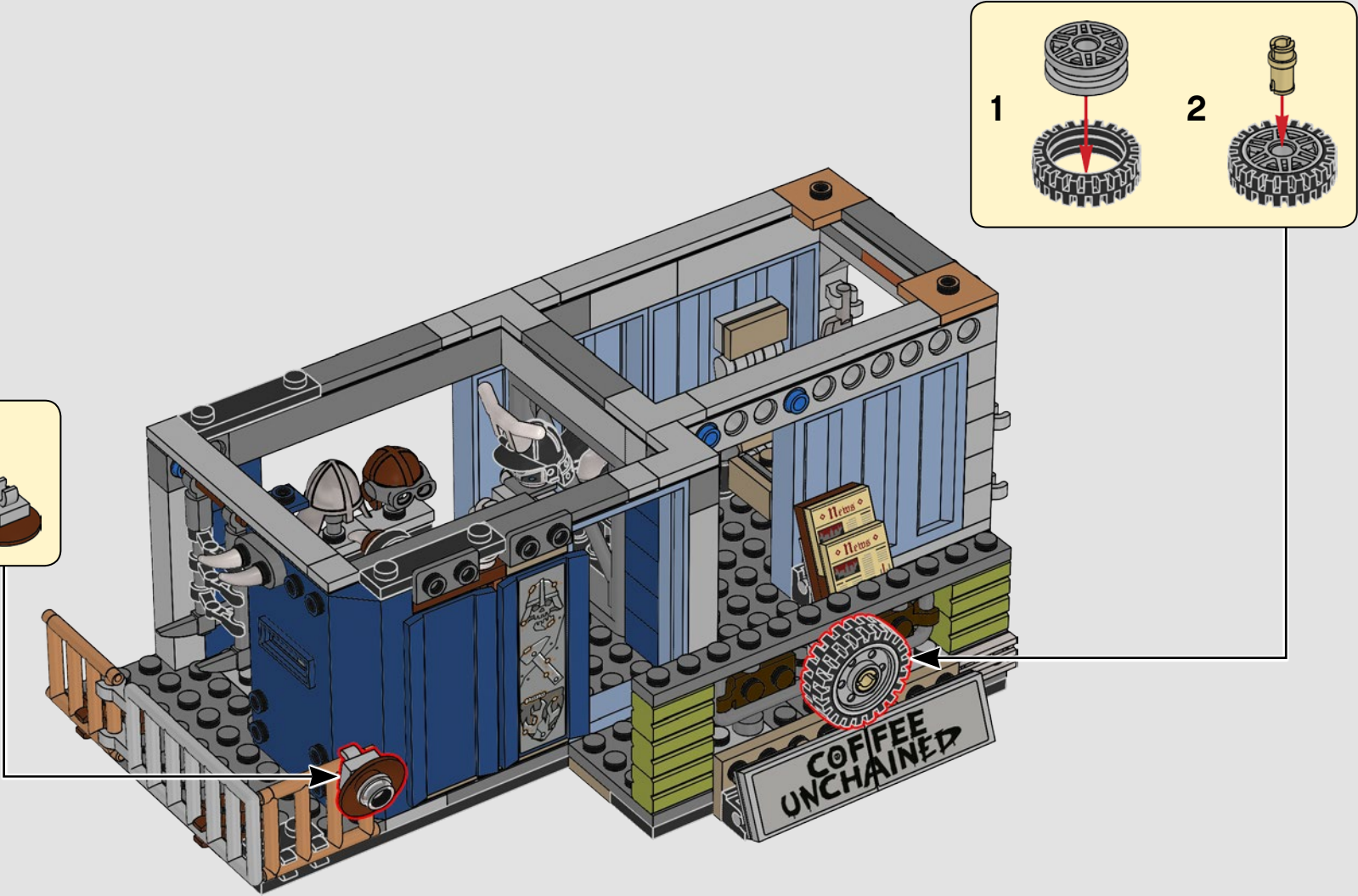

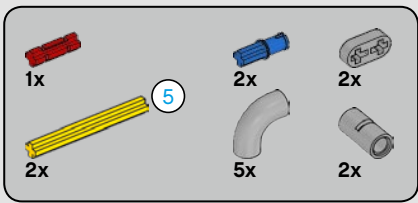

# 504

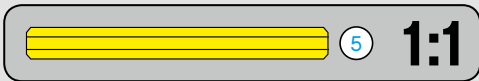
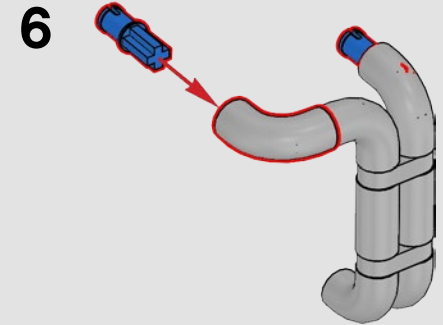
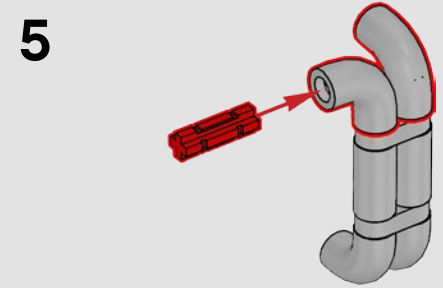
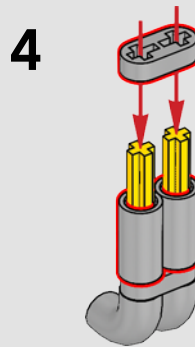
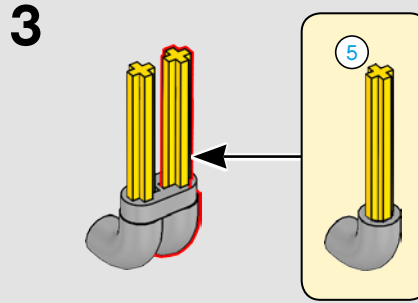
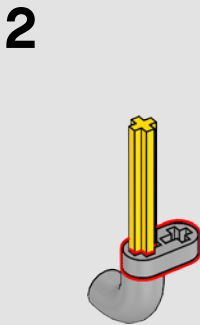
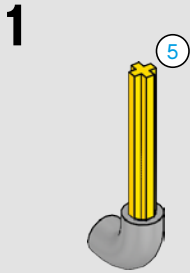

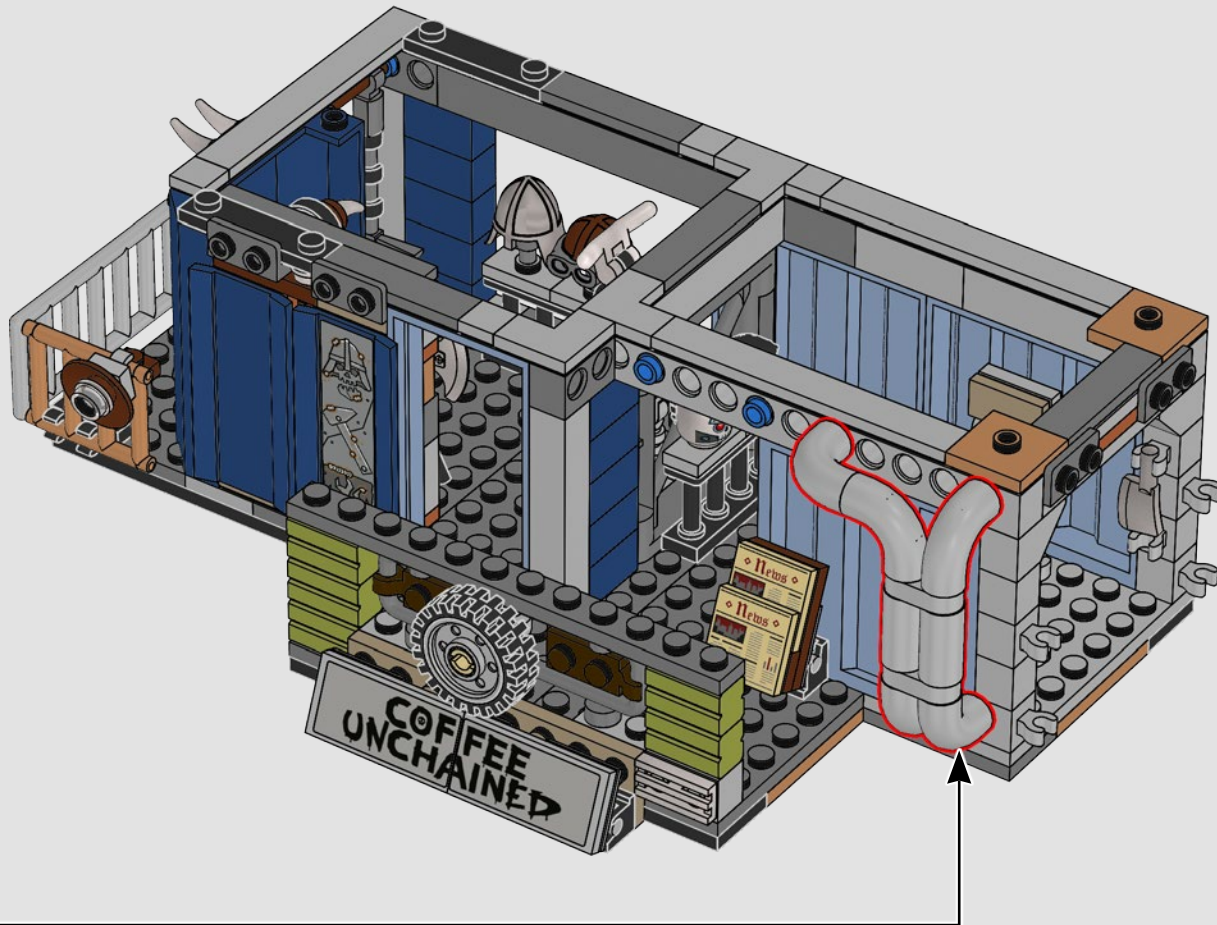

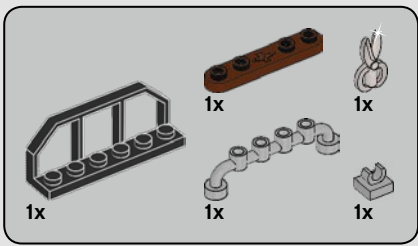

505

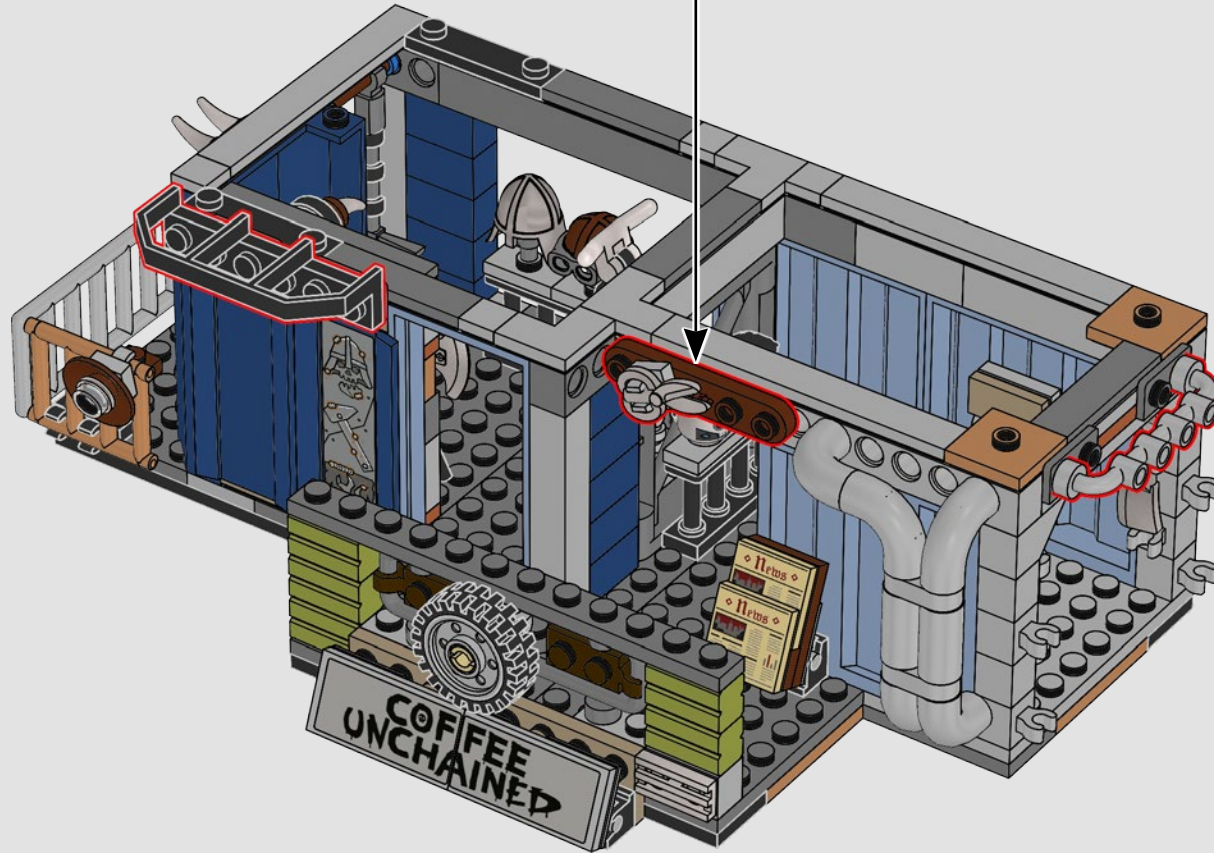
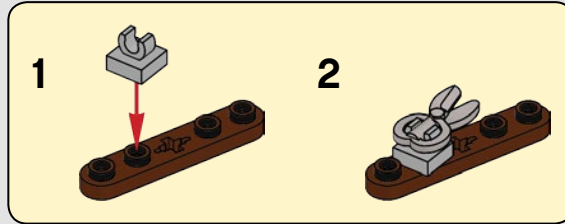

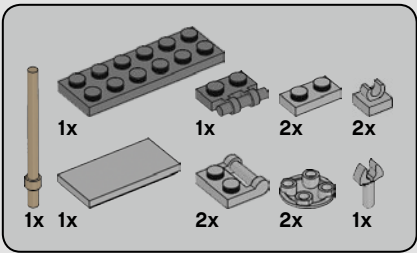

506

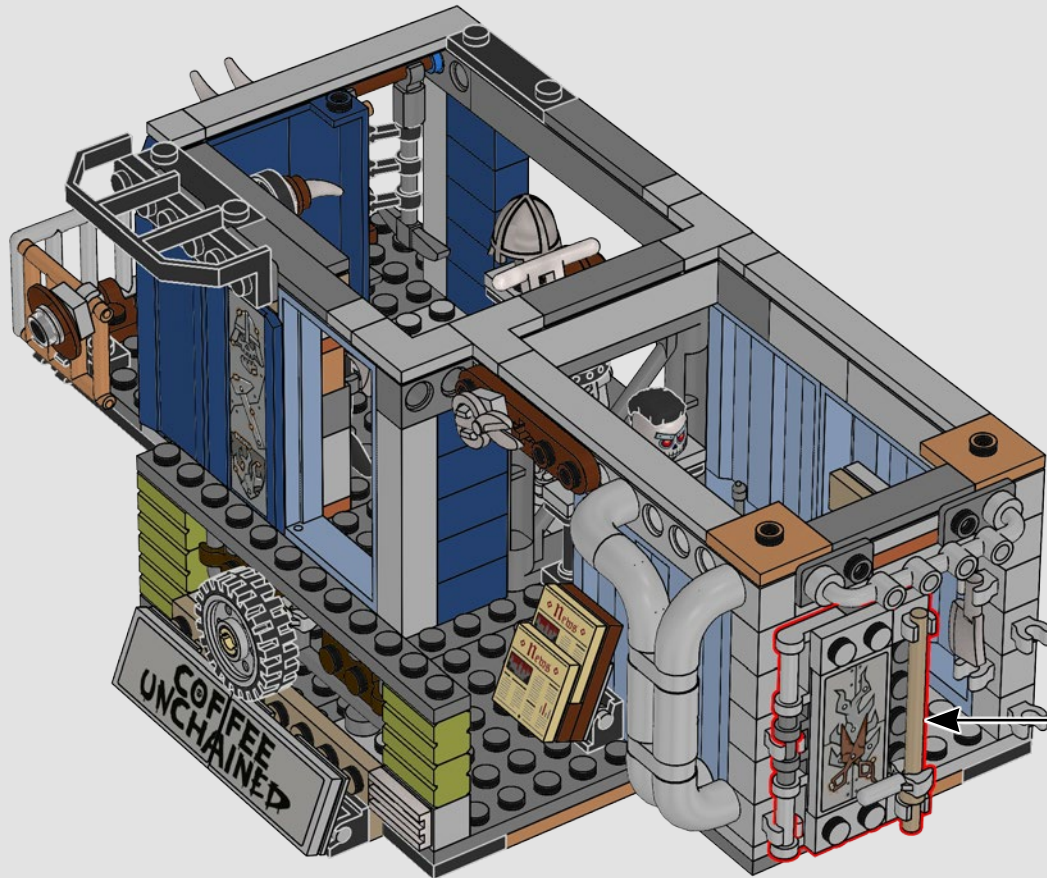
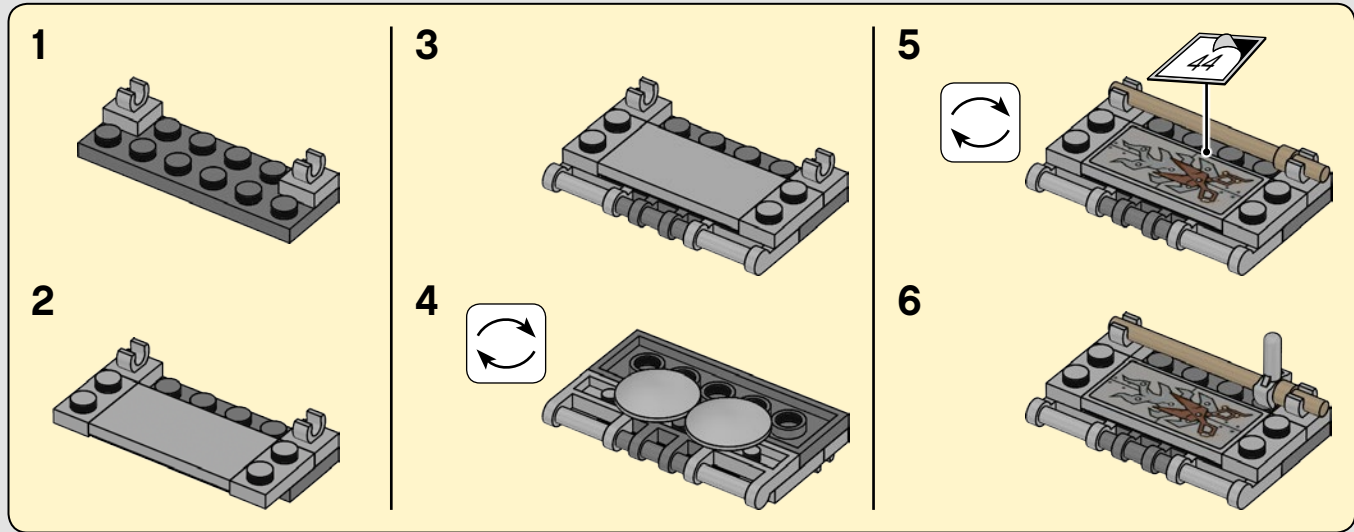

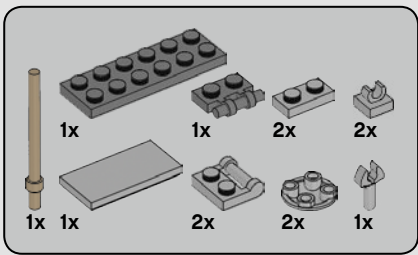

507

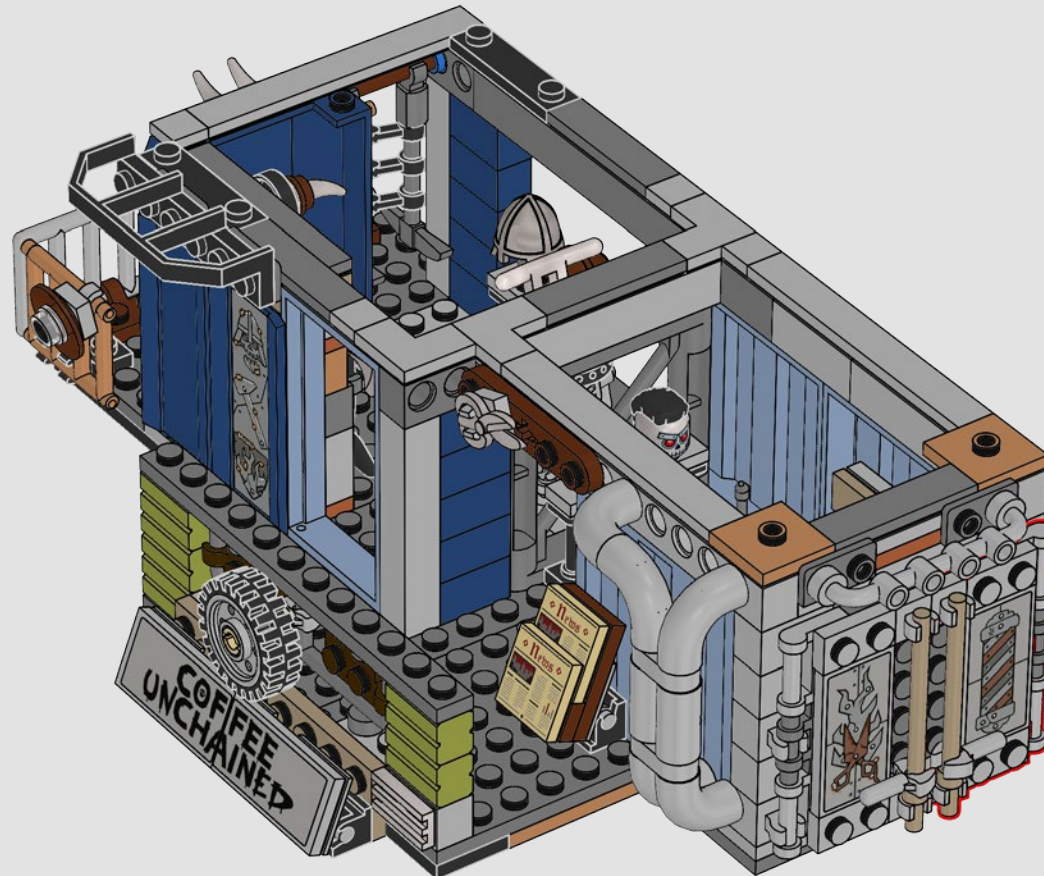
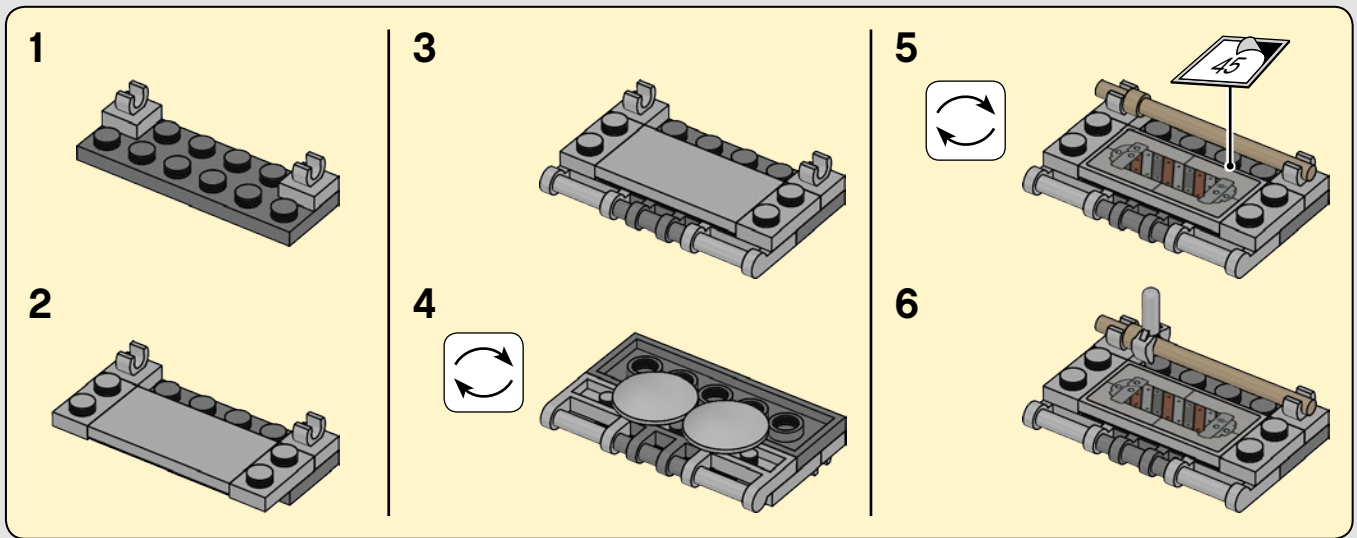

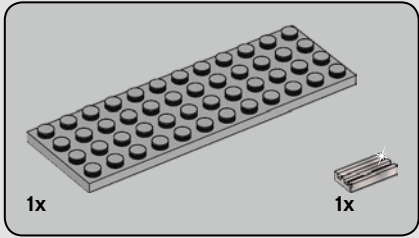
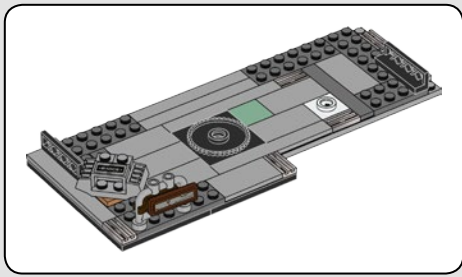

508

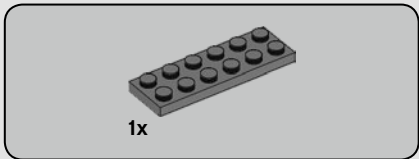
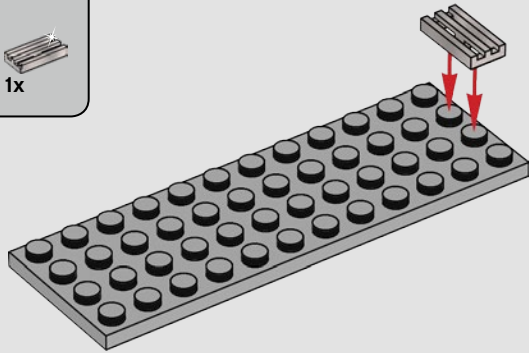

509

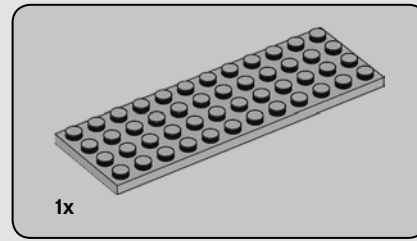
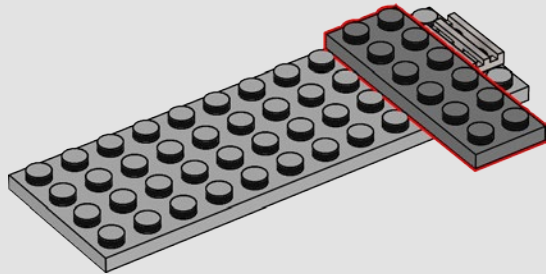

510

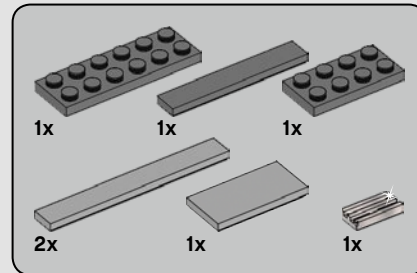
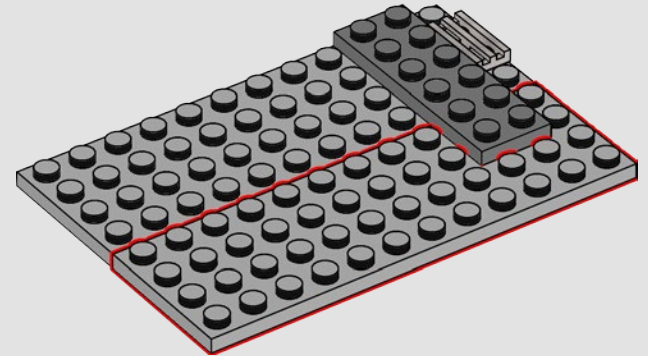

511

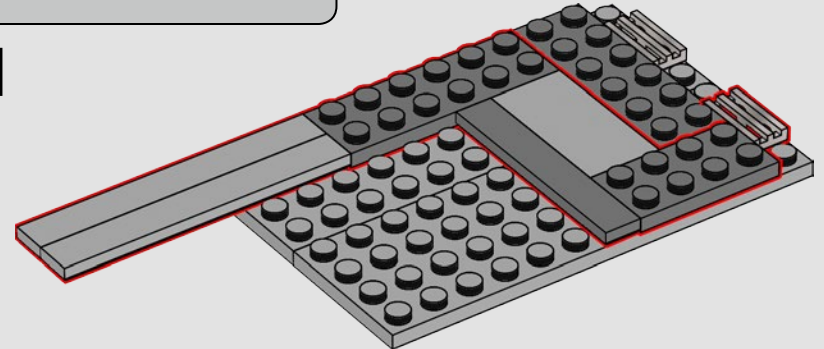



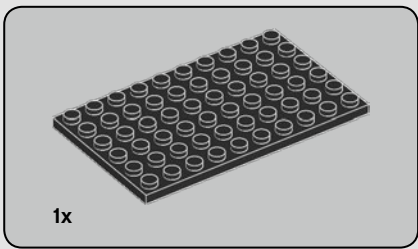

512

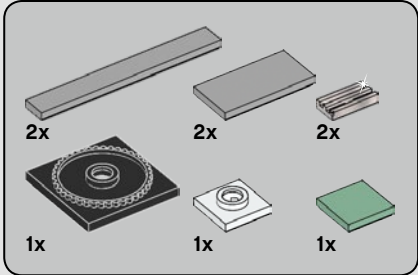
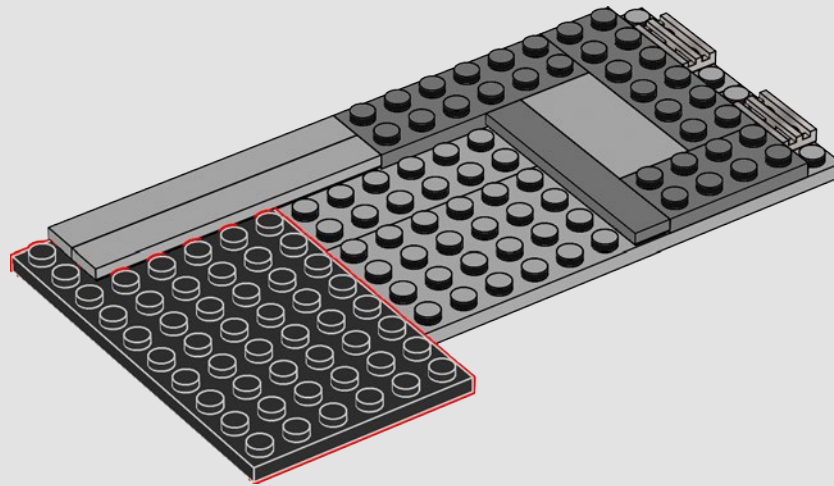

513

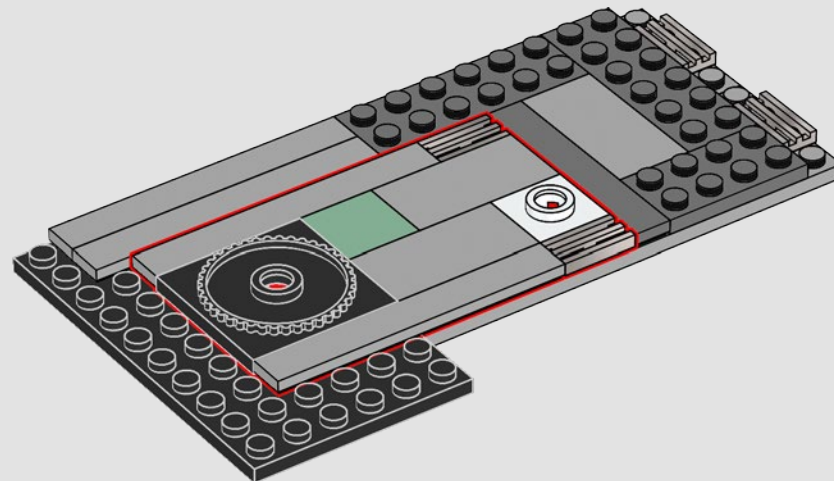

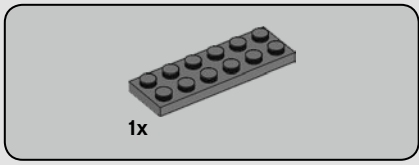

514

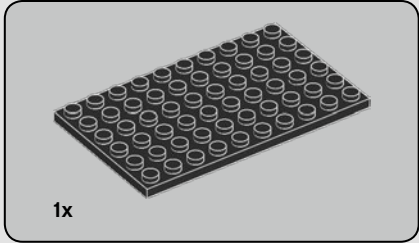
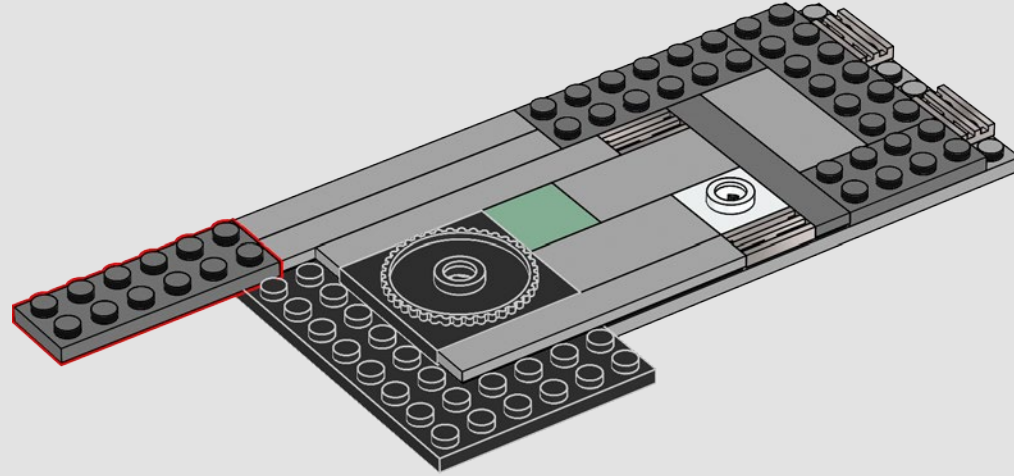

515

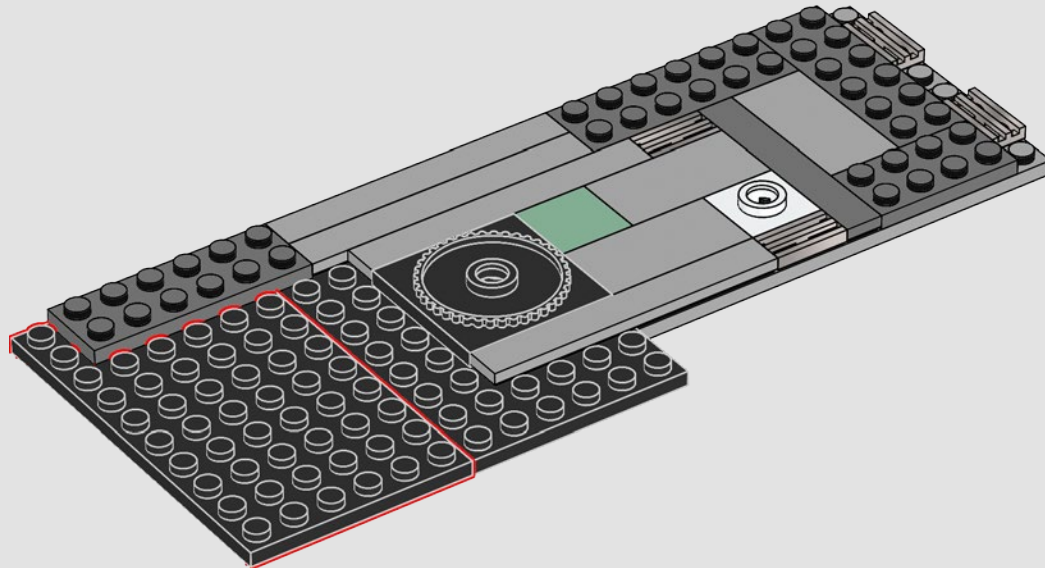

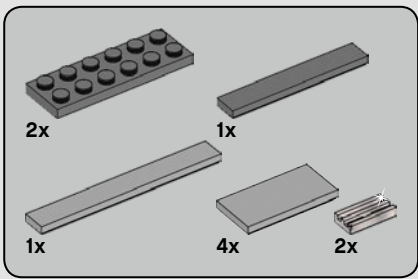

**516**

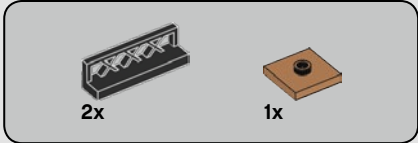
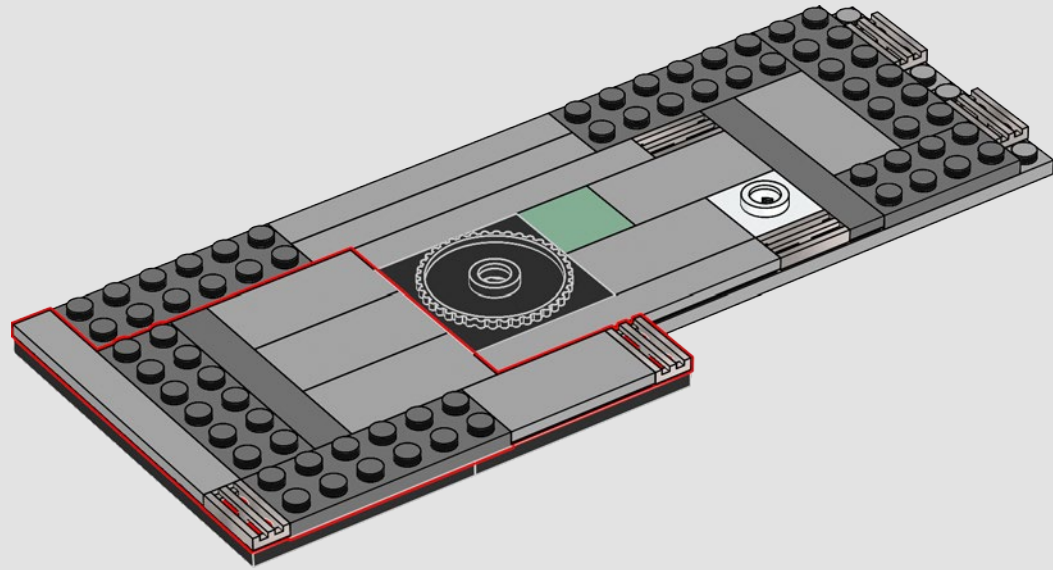

**517**

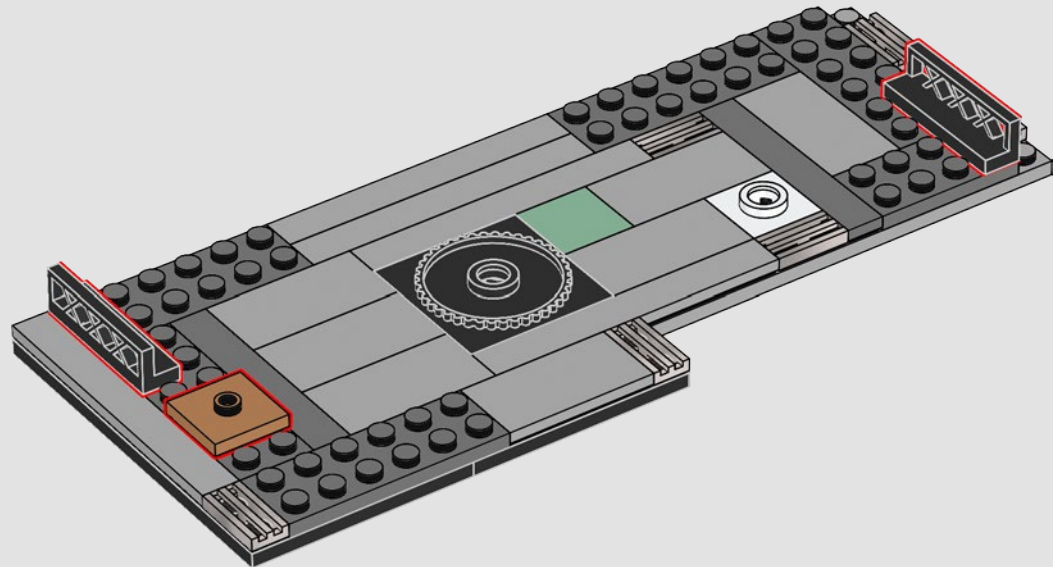

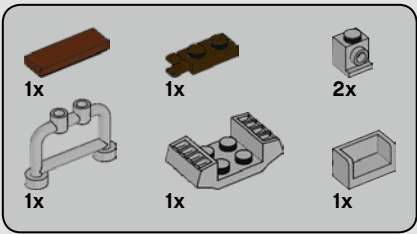

# 518

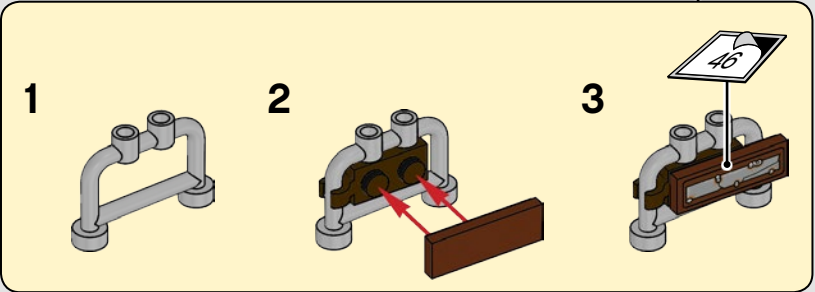
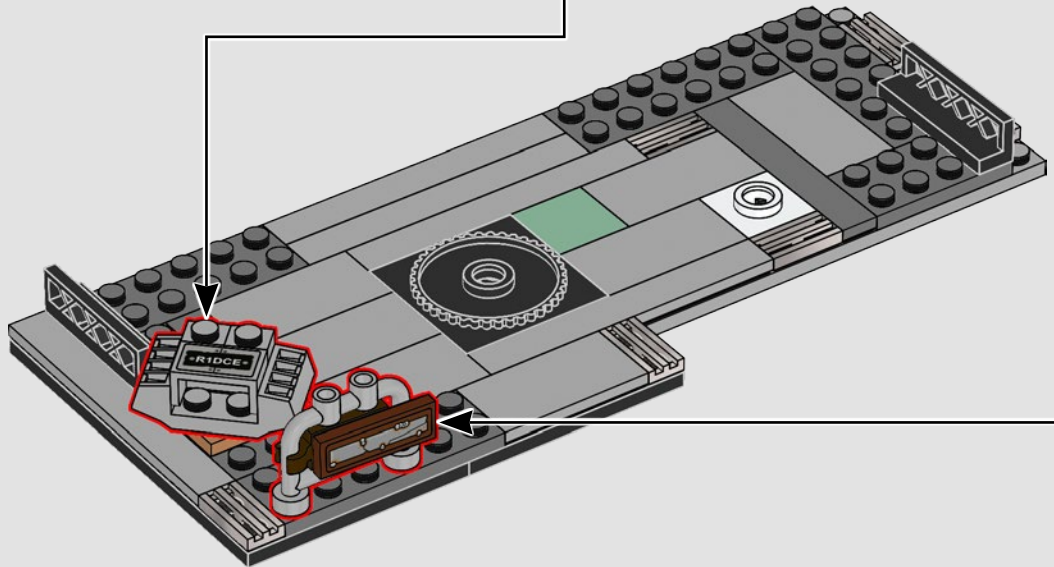
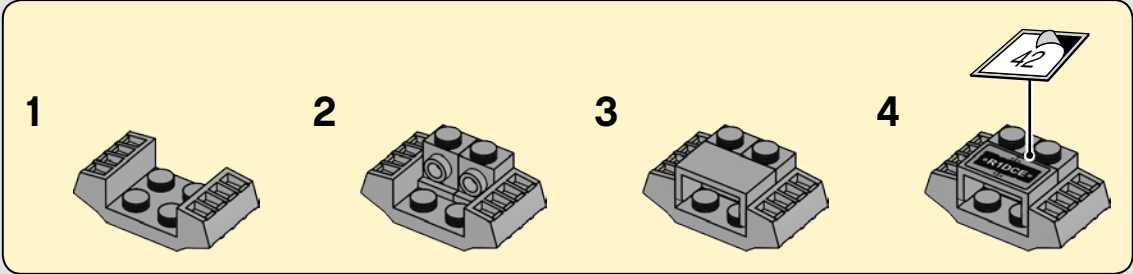

519

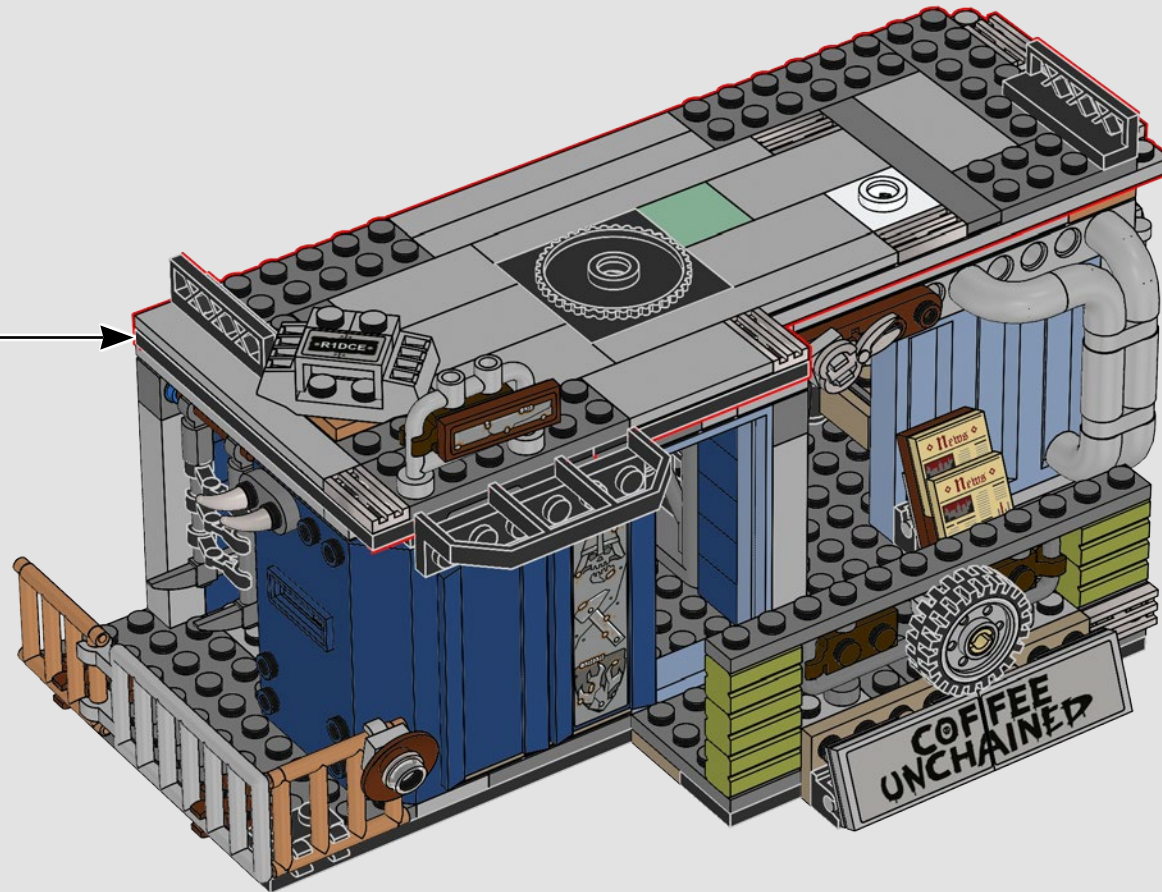



14

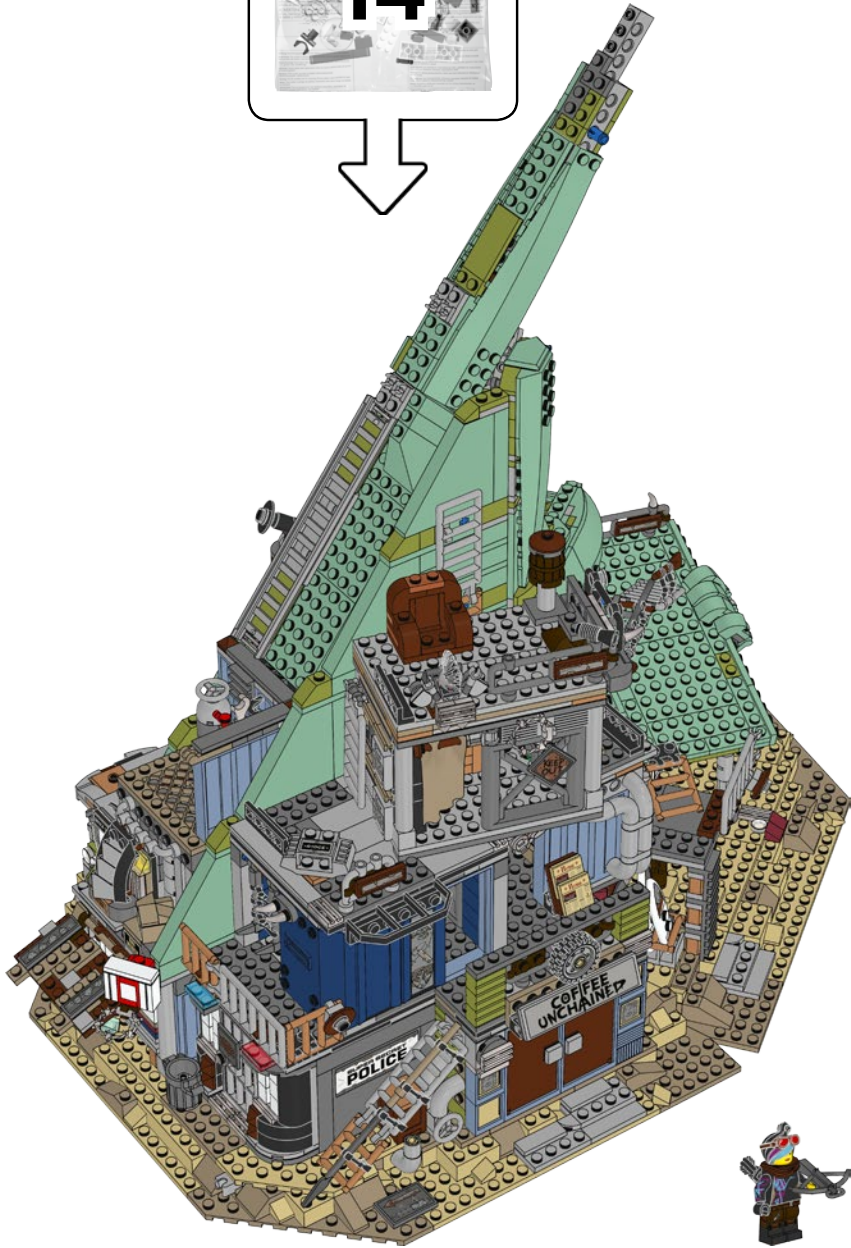

1



2



3



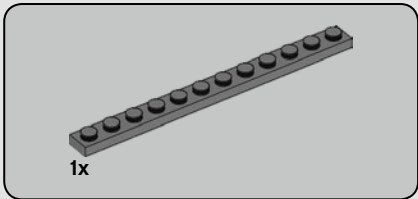
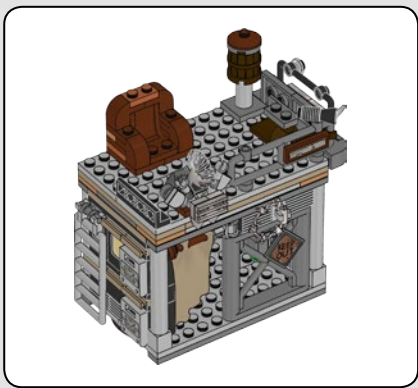

**520**

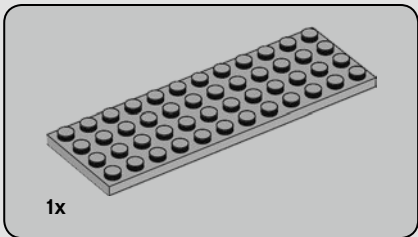
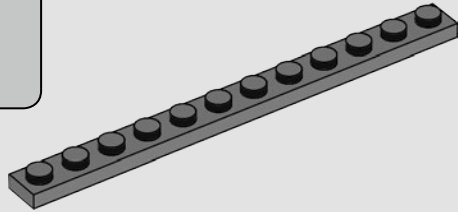

**521**

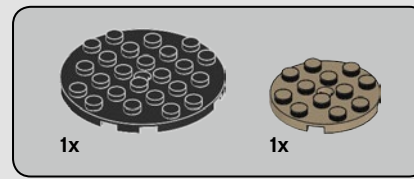
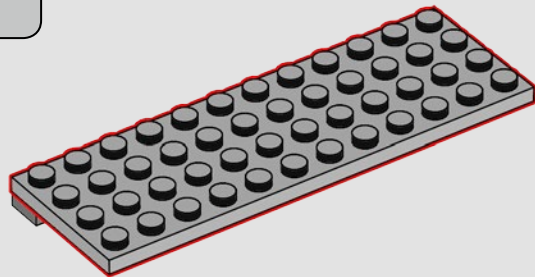

**522**

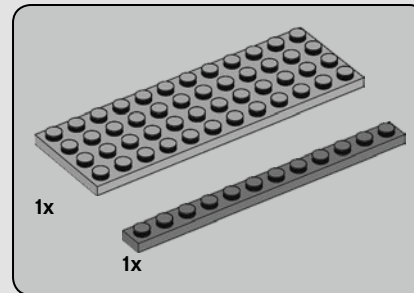
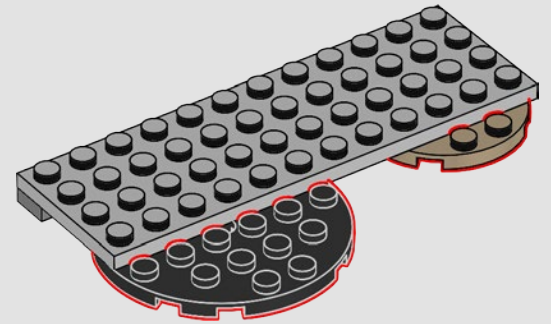

**523**

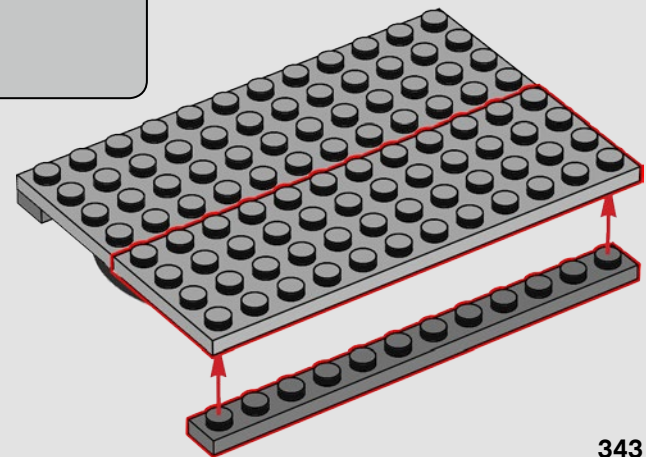

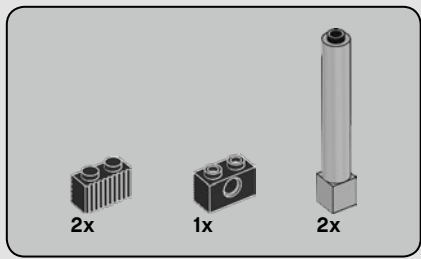

524

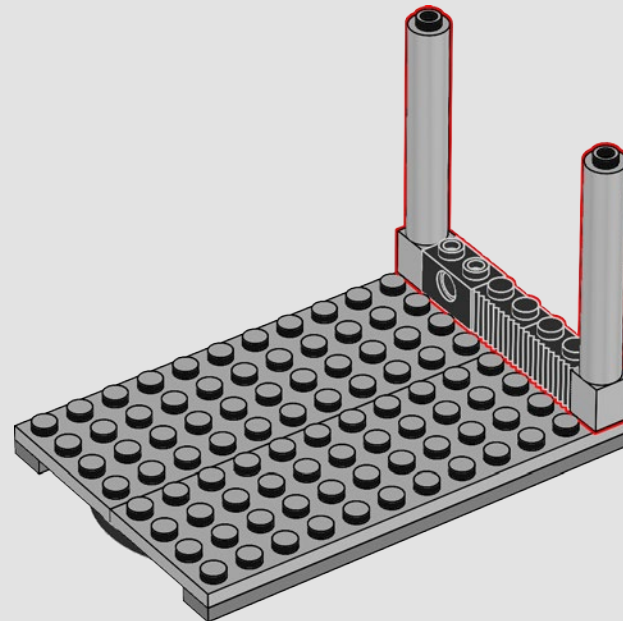



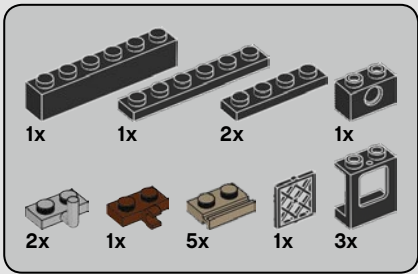

**525**

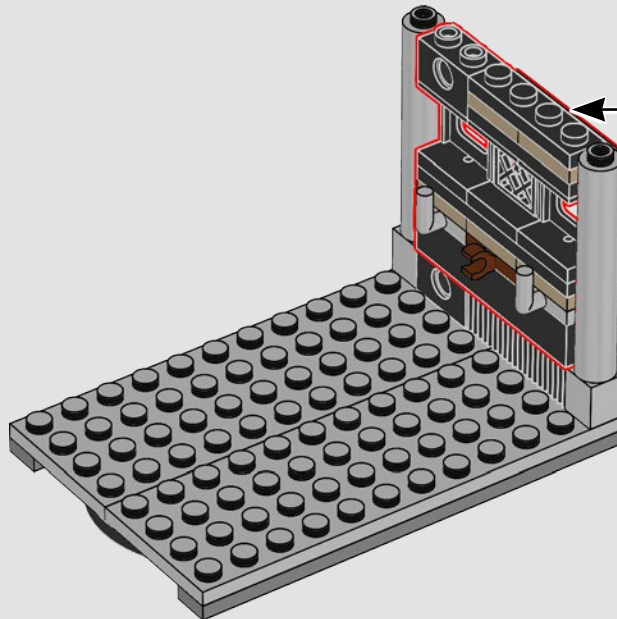
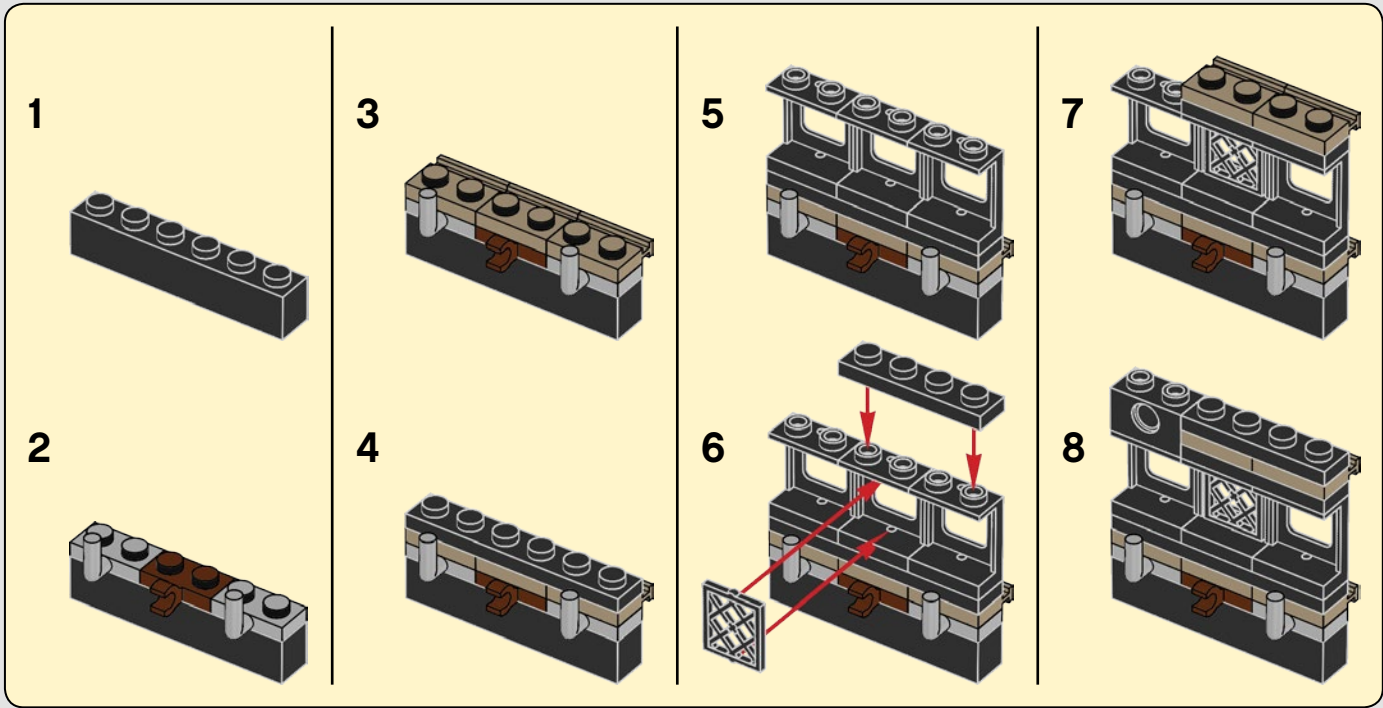

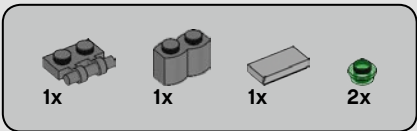

526

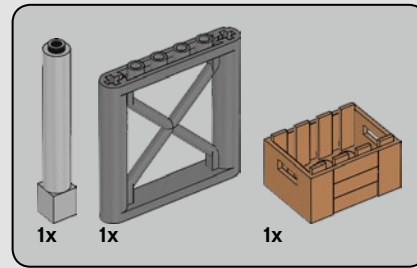
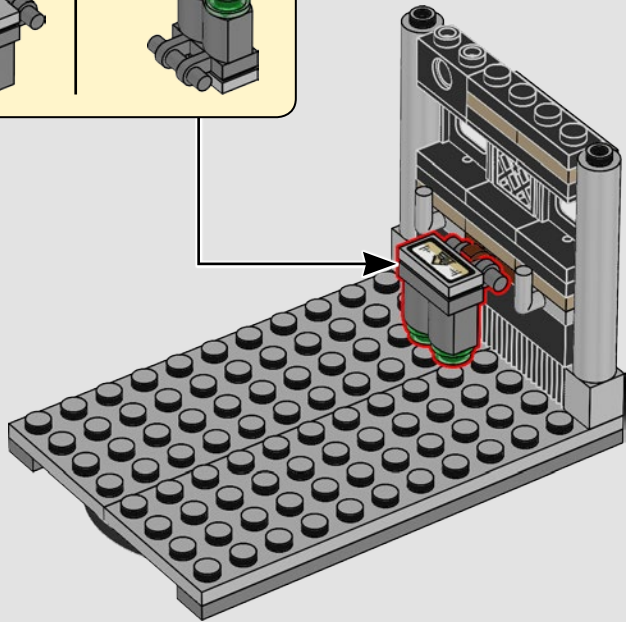
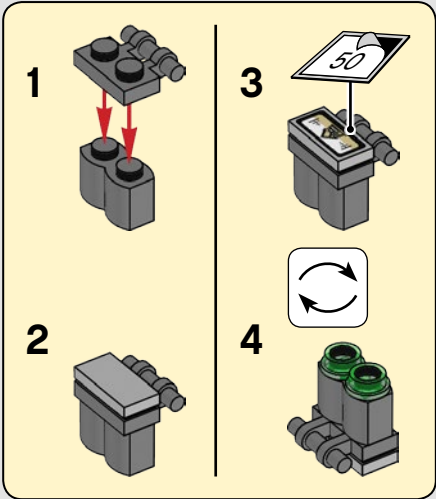

527

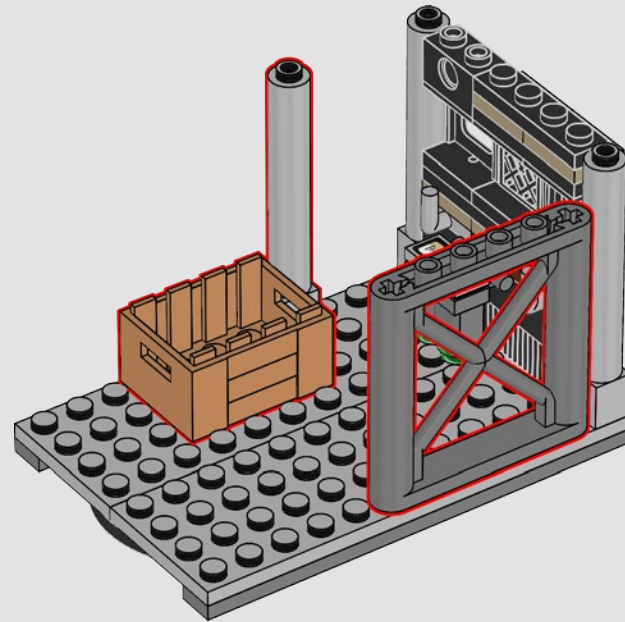

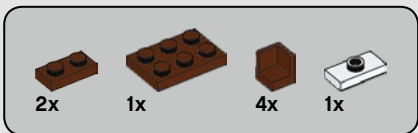

528

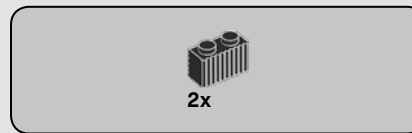
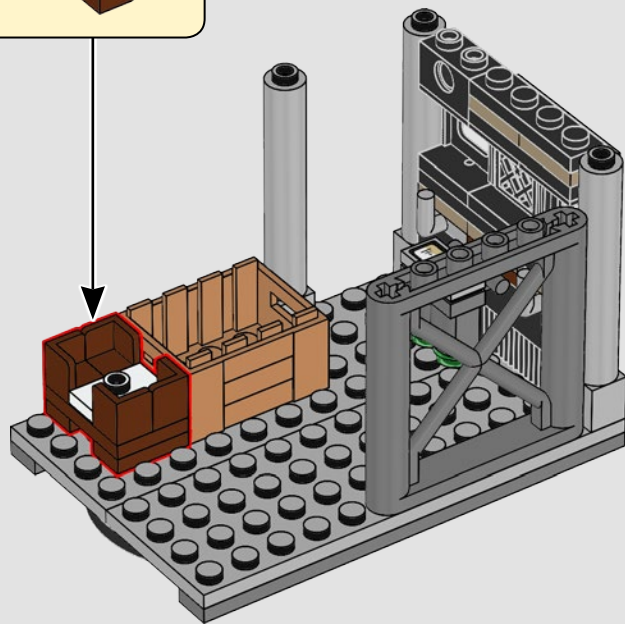
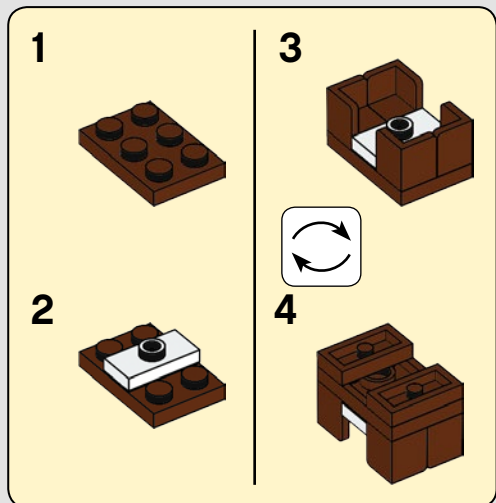

529

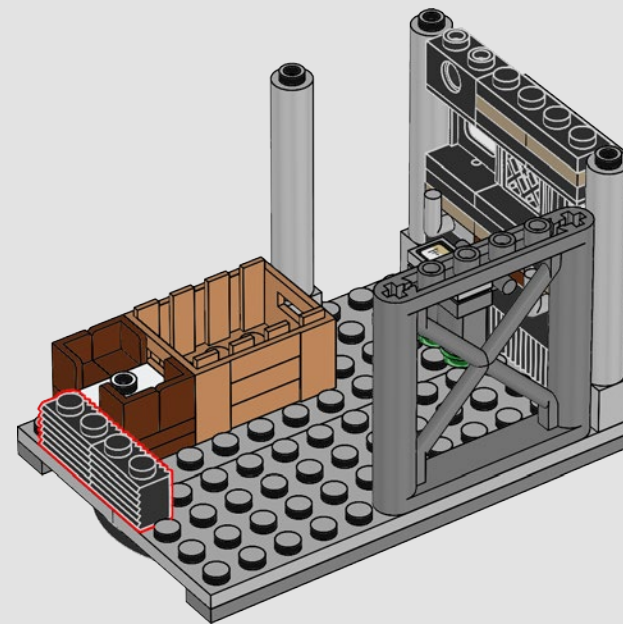

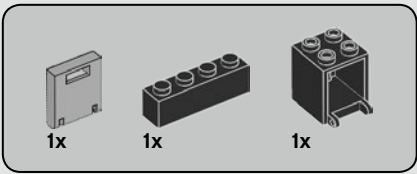

# 530

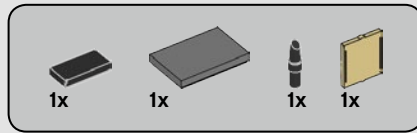
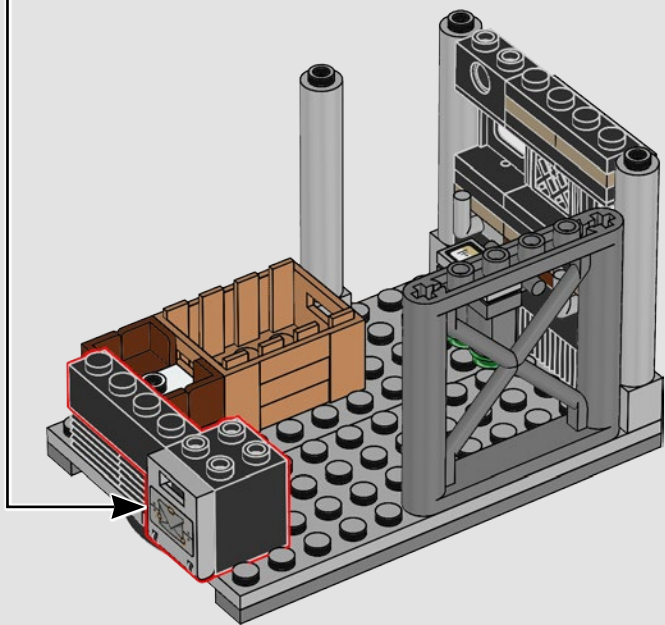
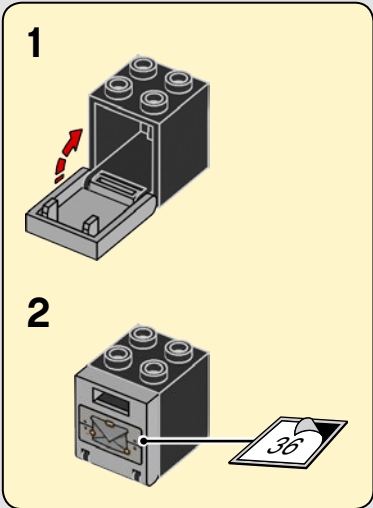

# 531

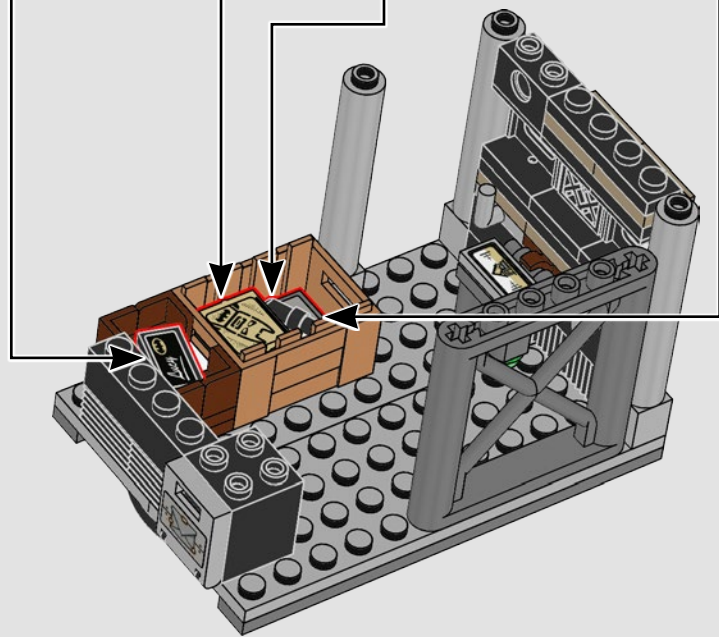
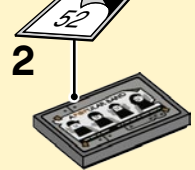
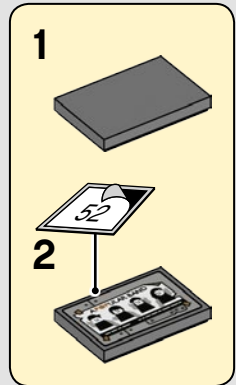
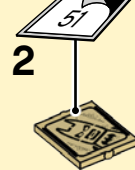
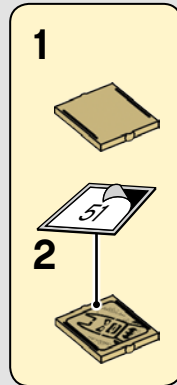
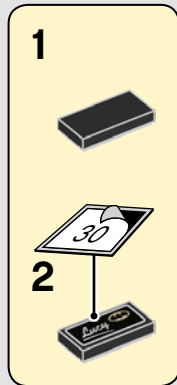

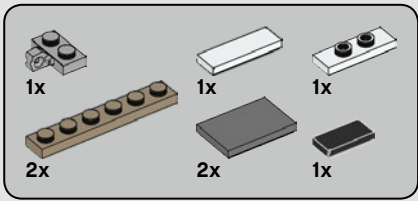

532

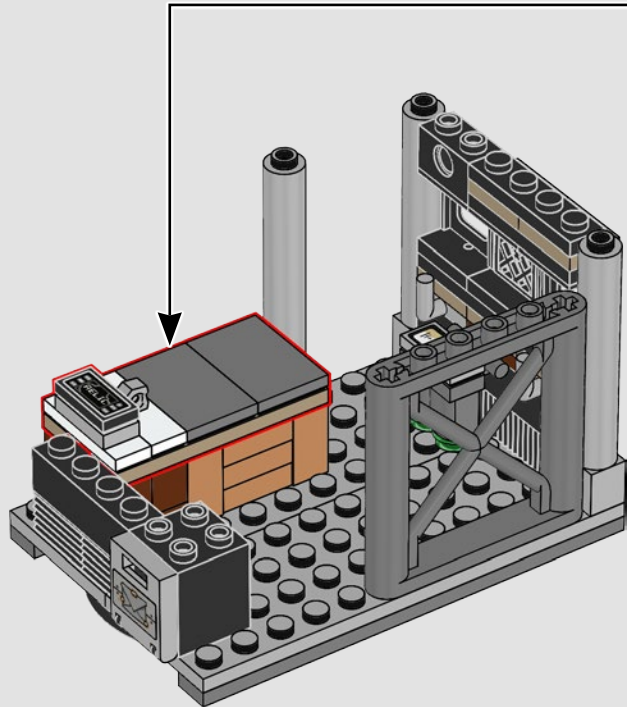
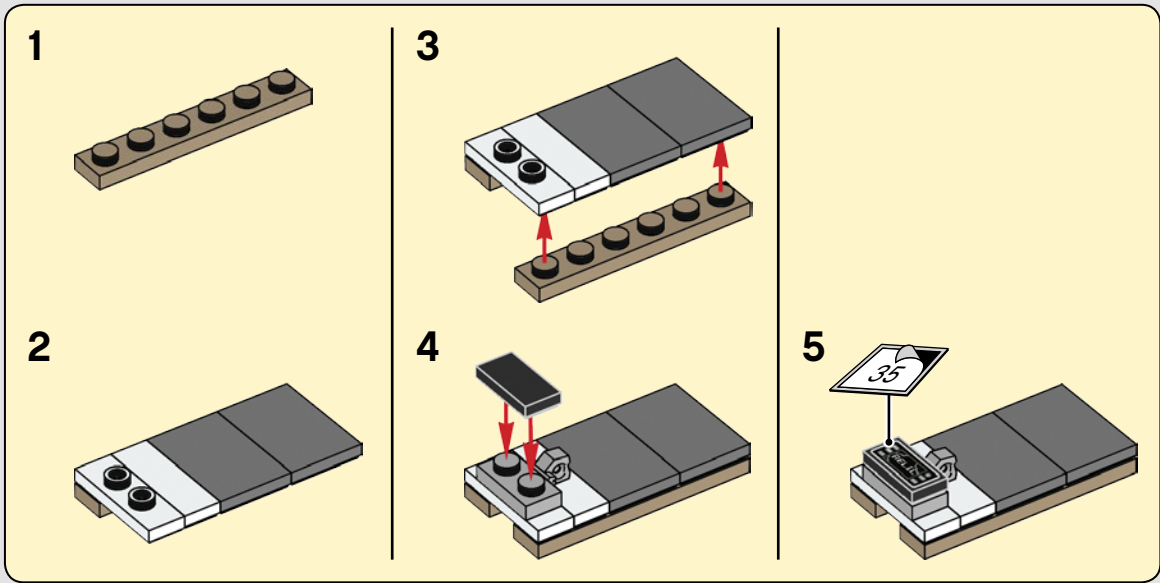

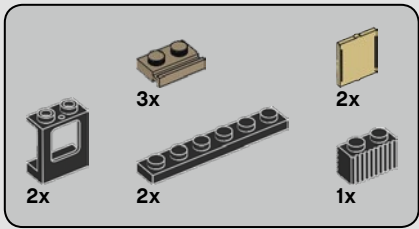

533

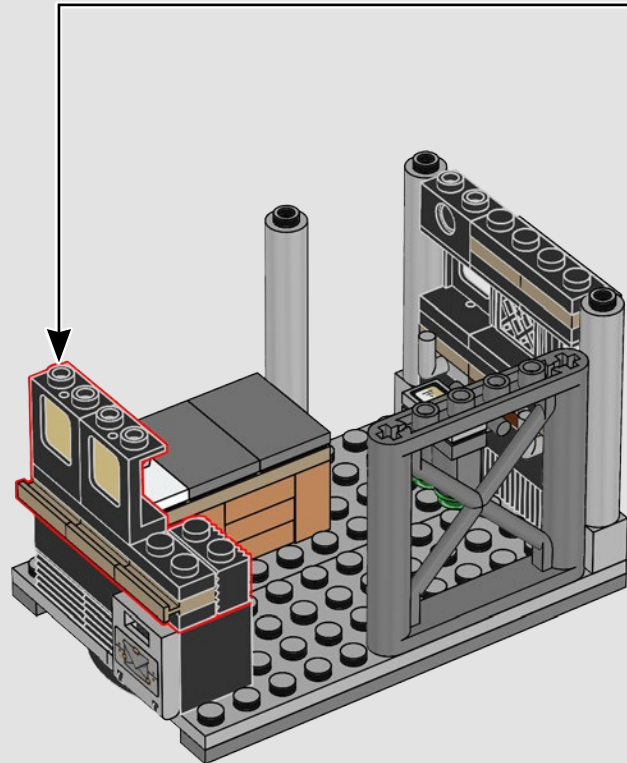
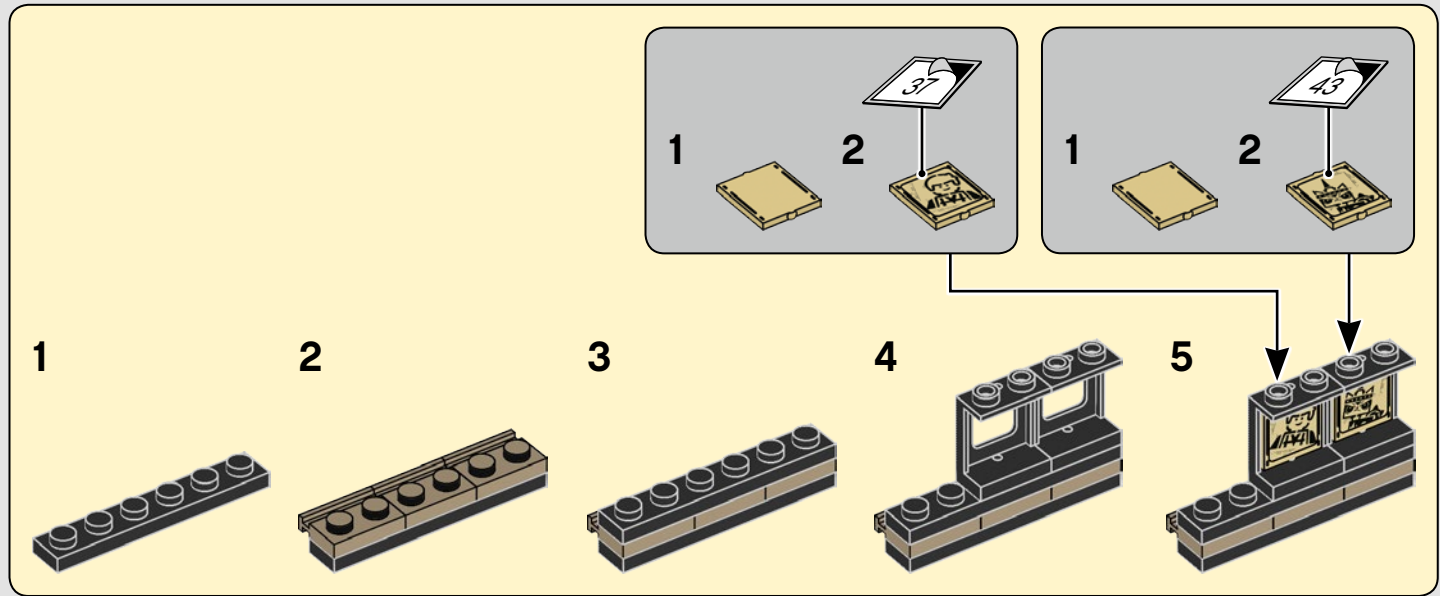

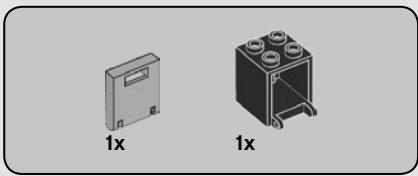

534

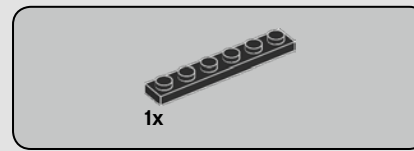
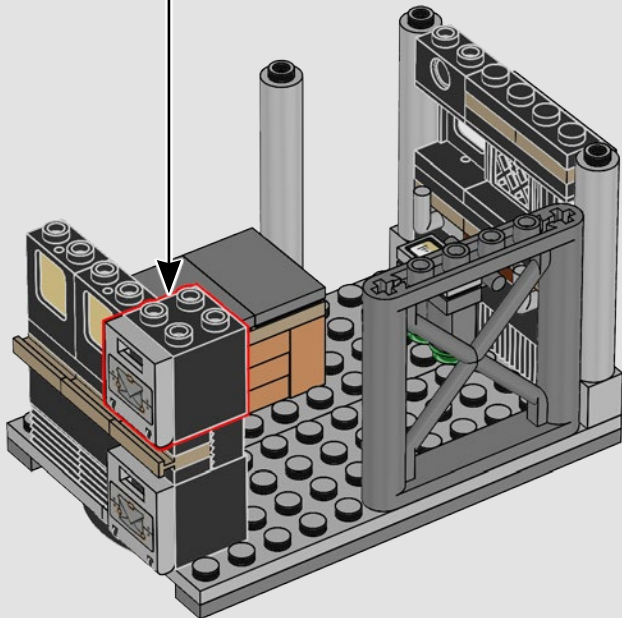
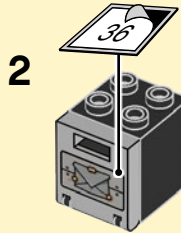
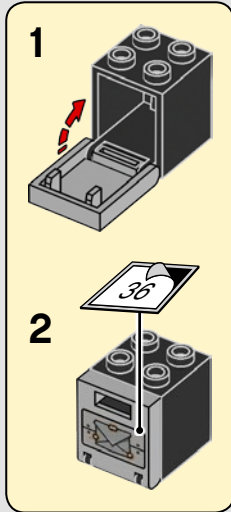

535

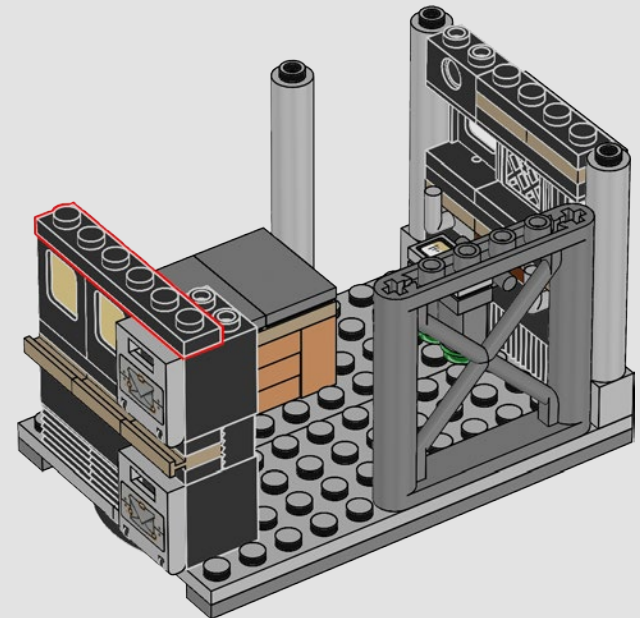

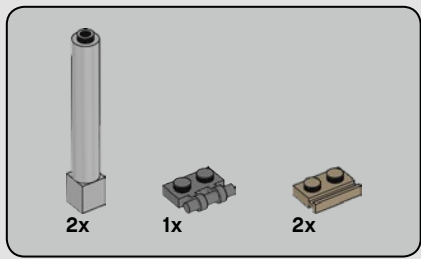

536

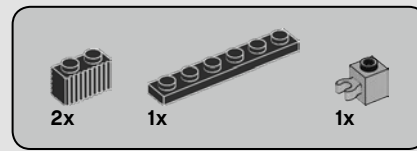
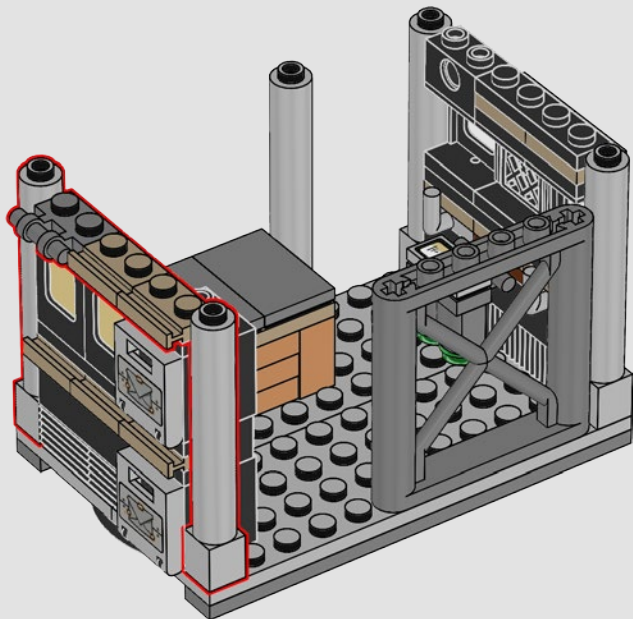

537

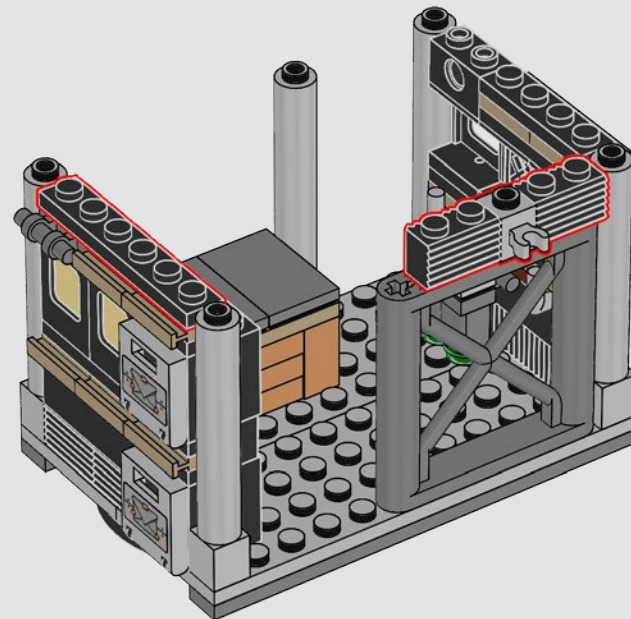



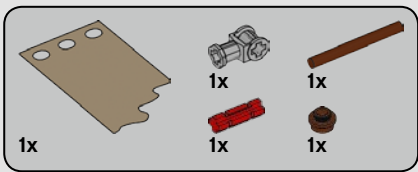

538

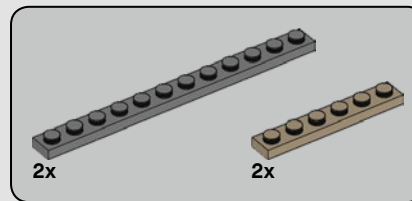
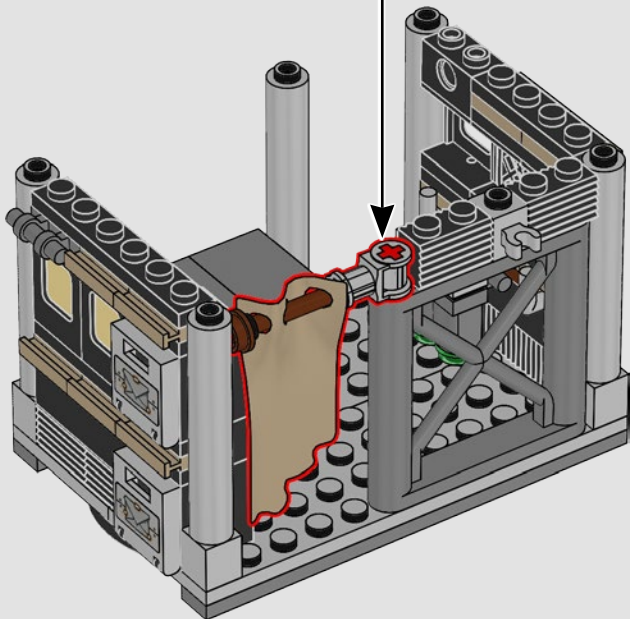
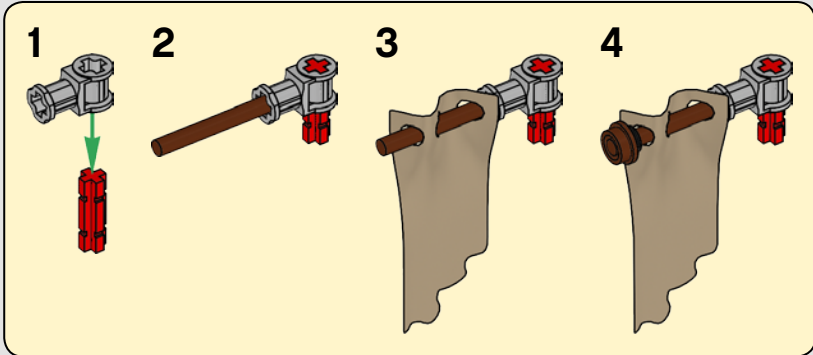

539

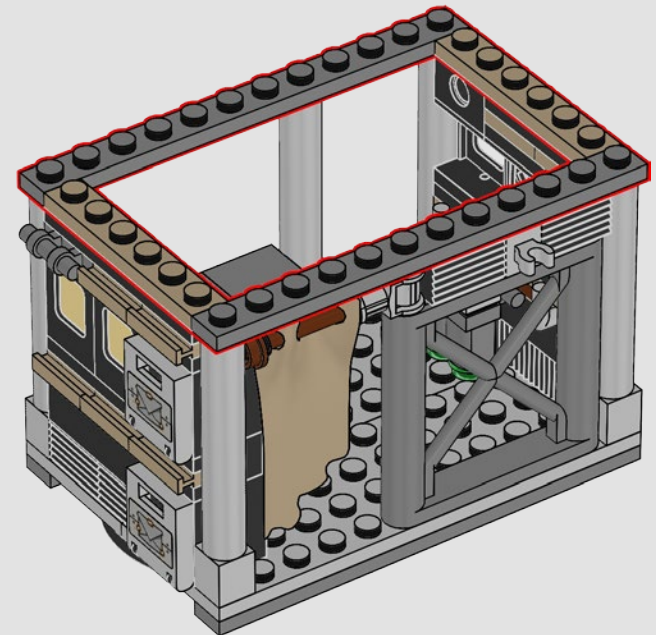

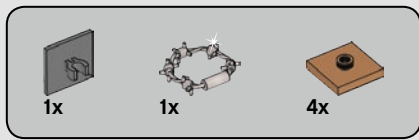

540

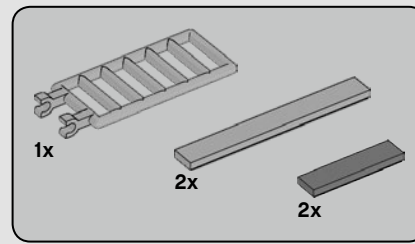
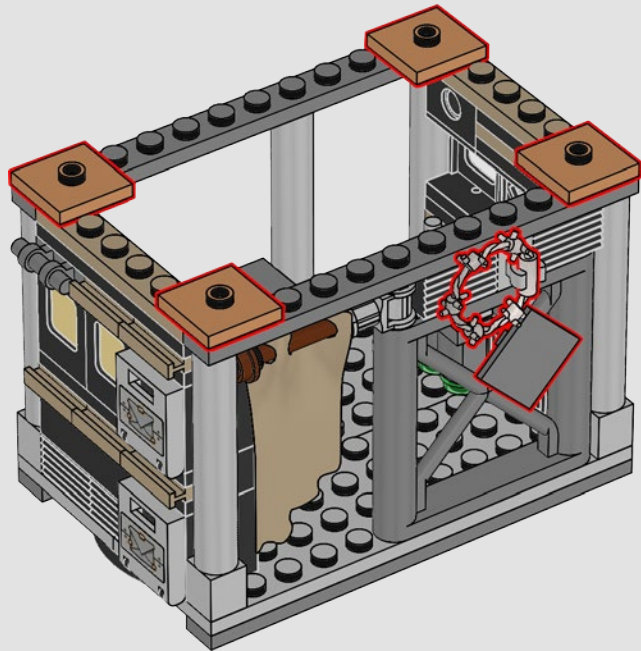

541

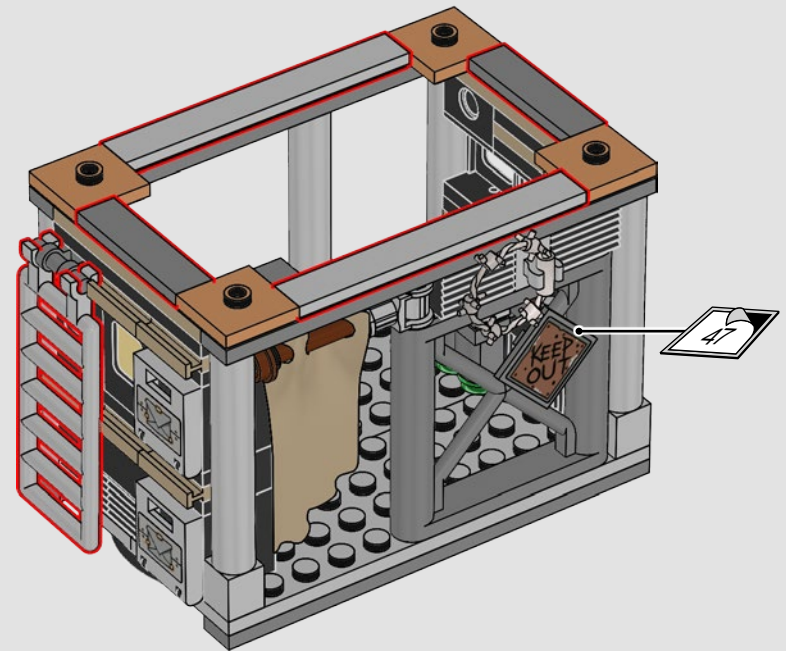

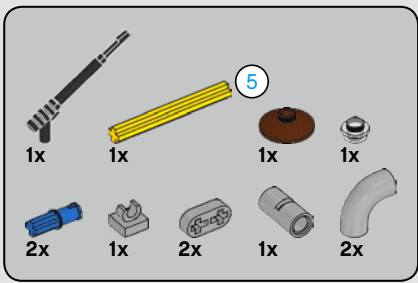

542

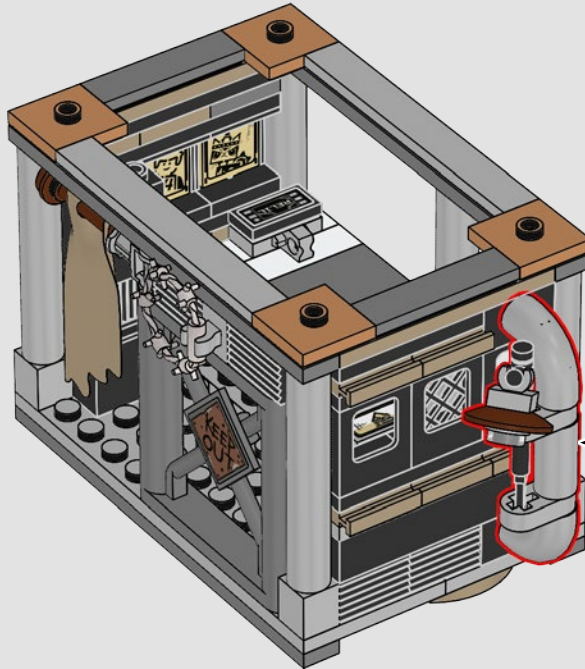
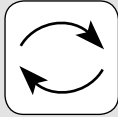
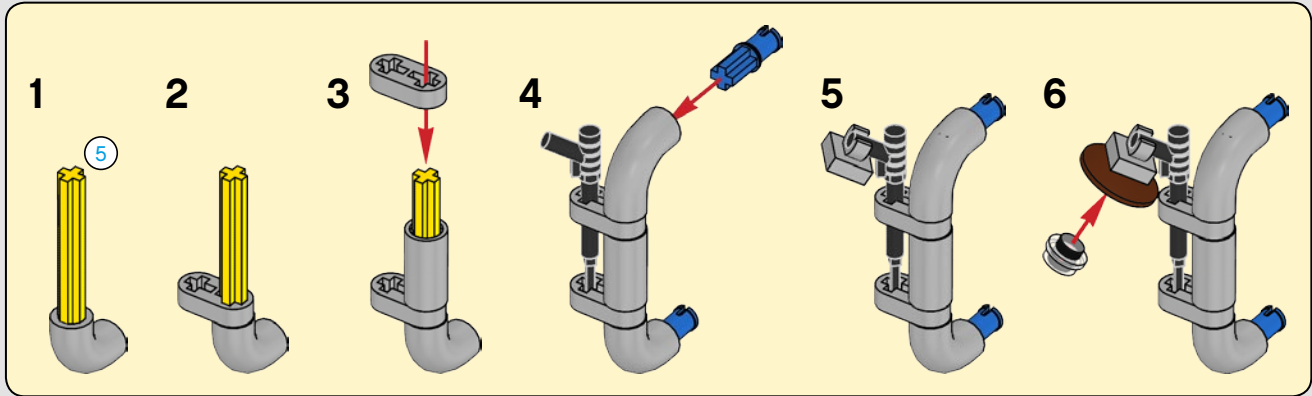
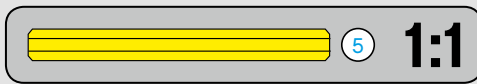

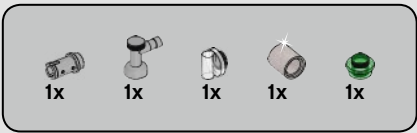

543

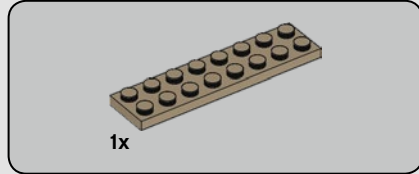
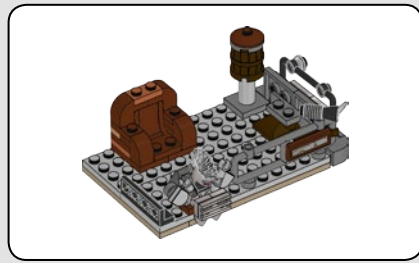
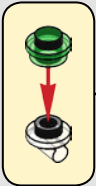
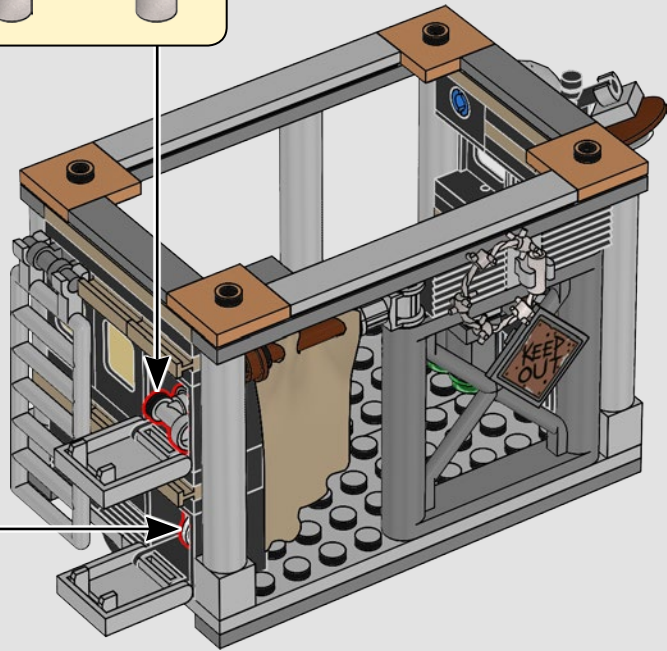
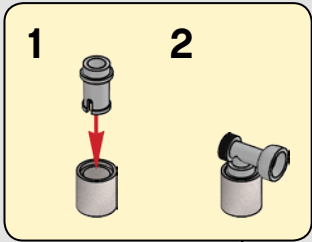
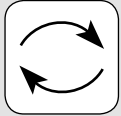

544

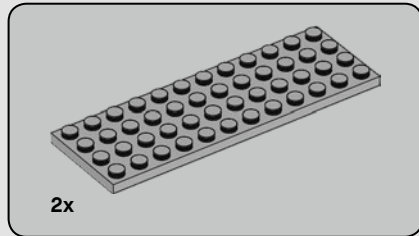
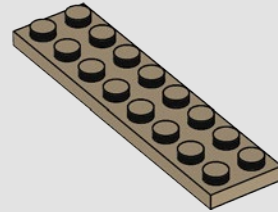

545

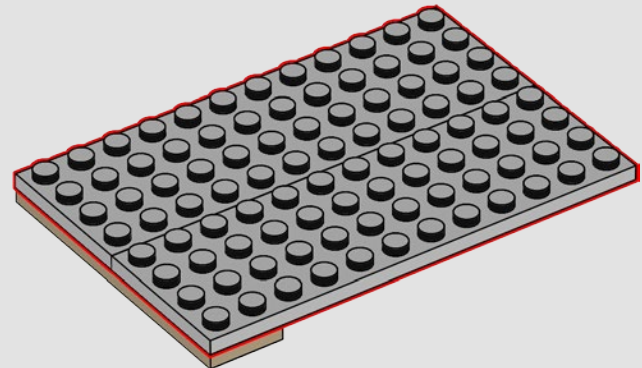

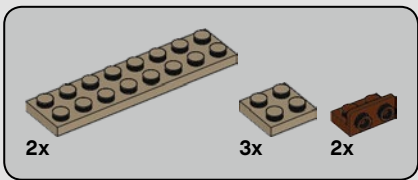

# 546

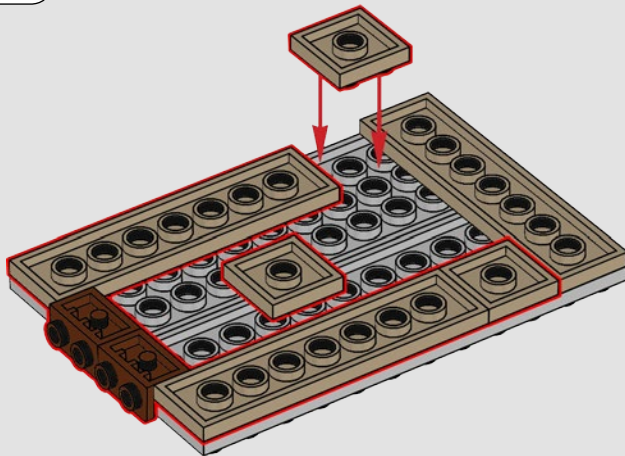
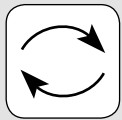

# 547

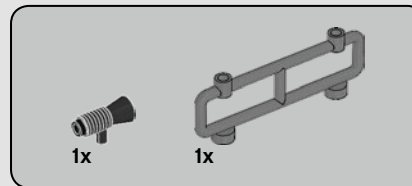
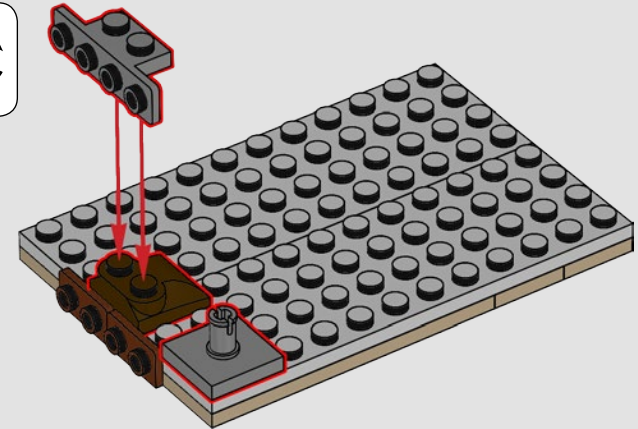
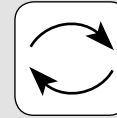

# 548

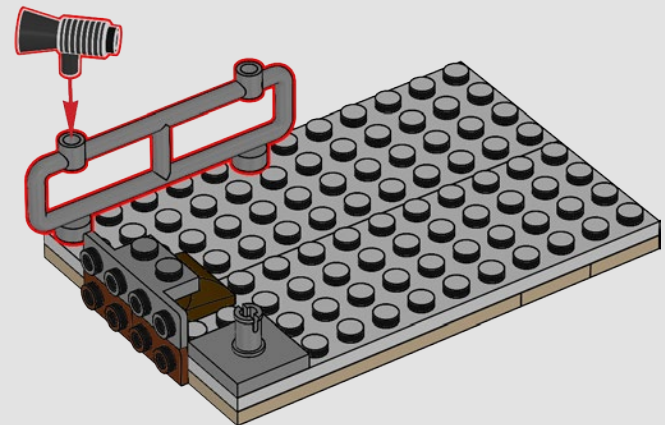

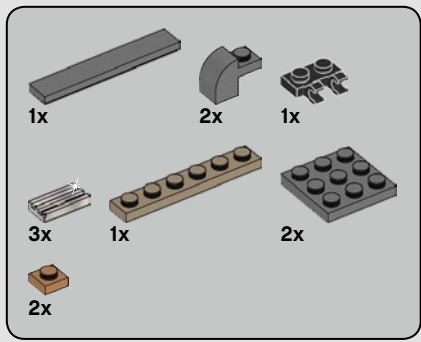

549

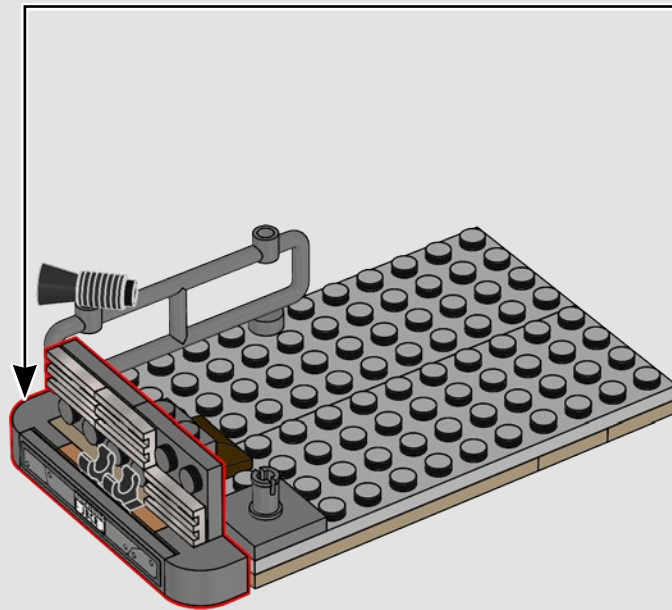
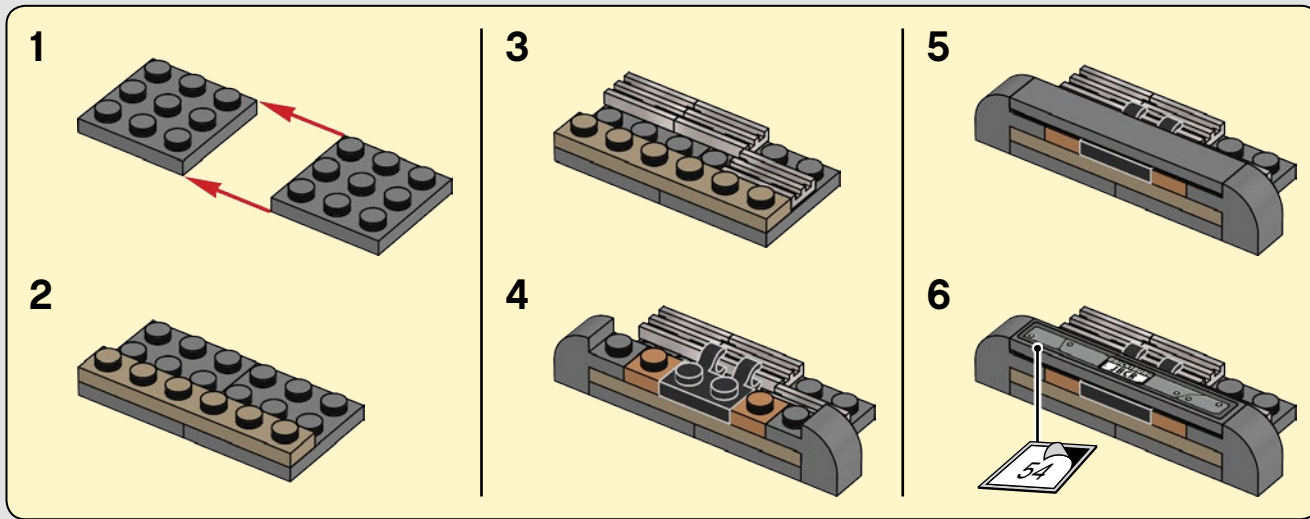

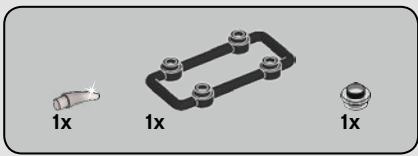

550

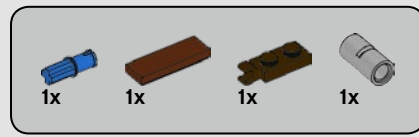
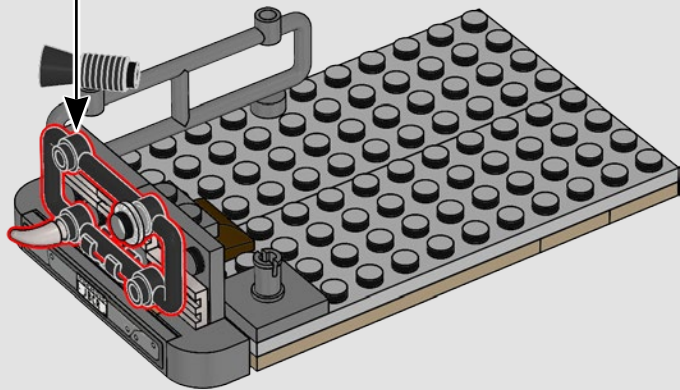
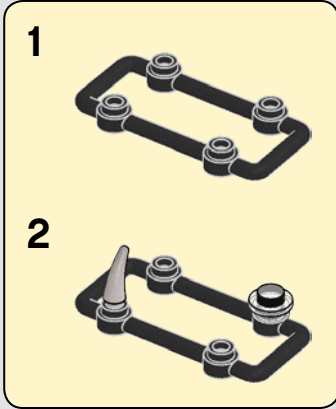

551

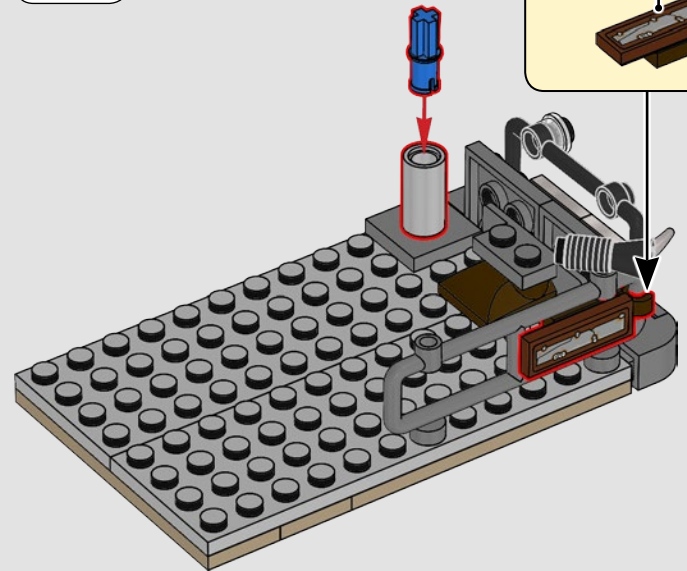
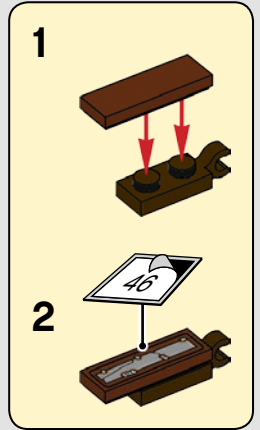
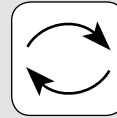

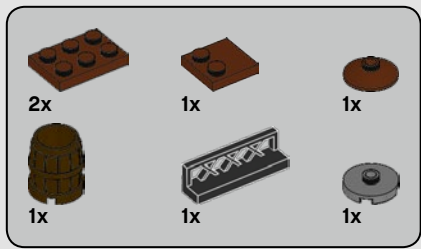

552

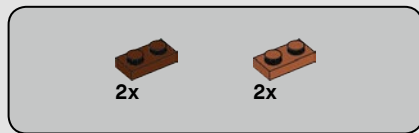
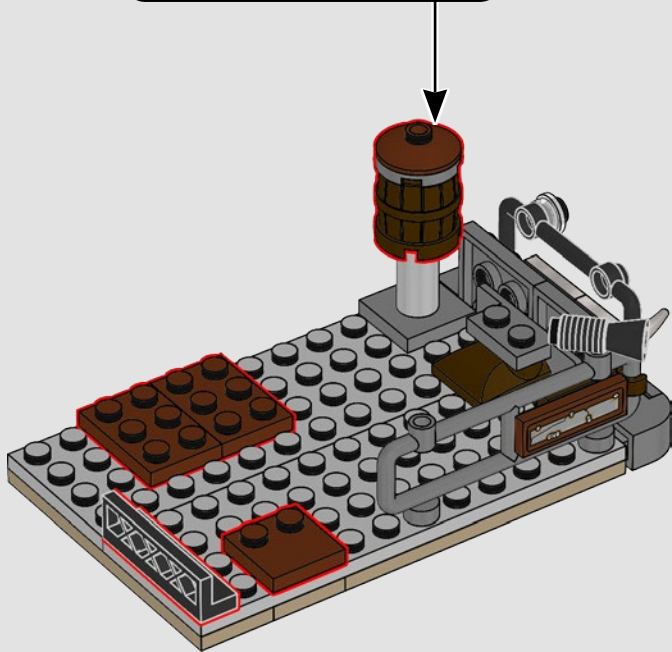
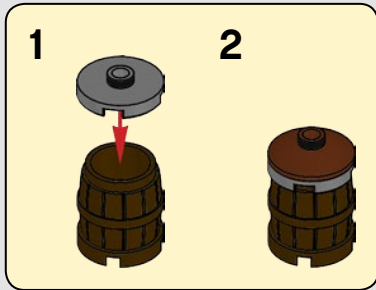

553

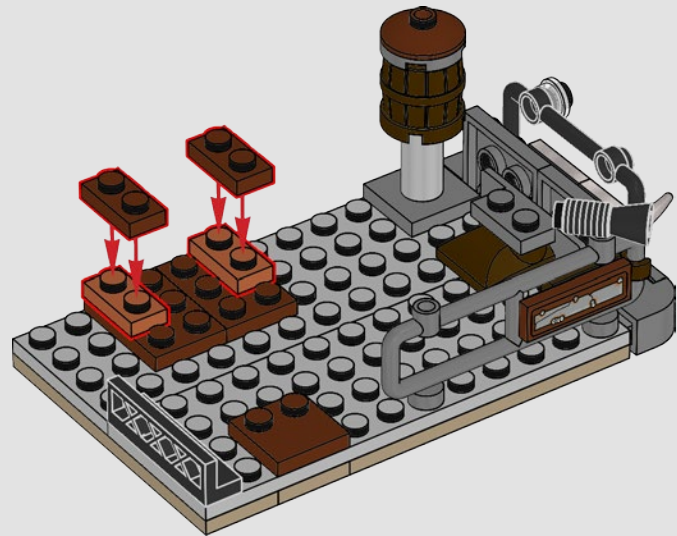



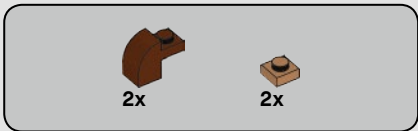

554

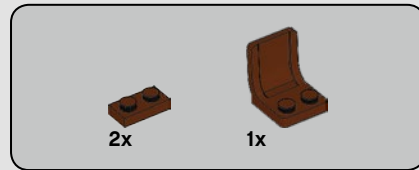
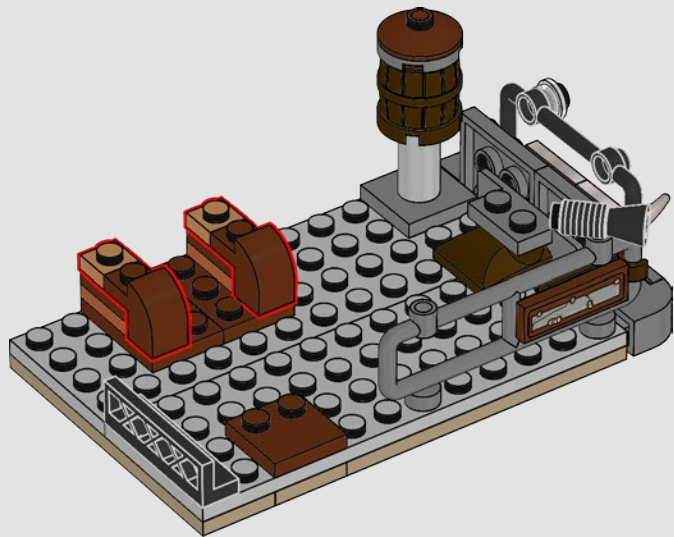

555

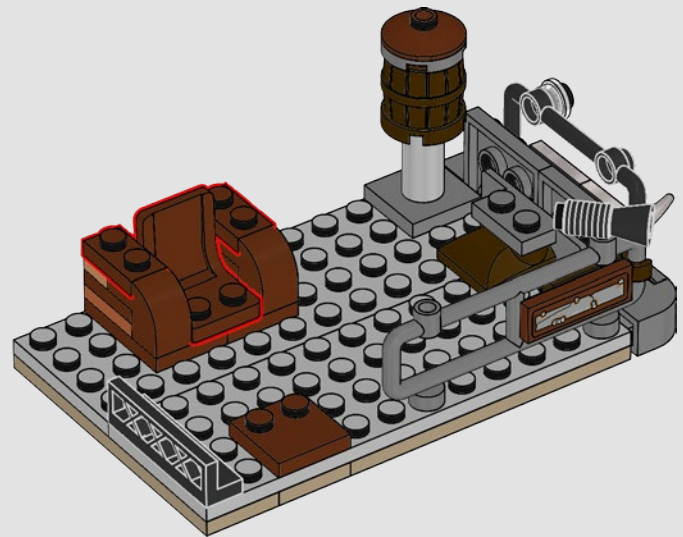

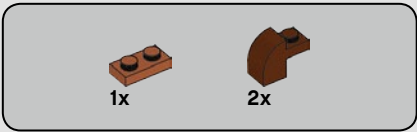

556

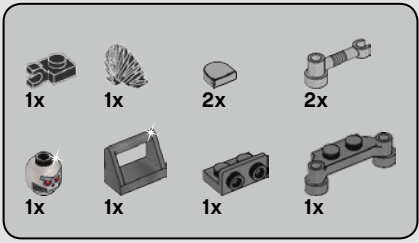
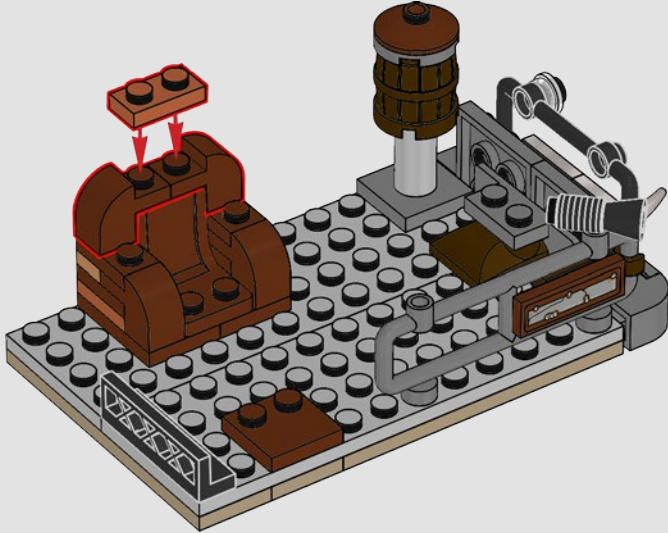

557

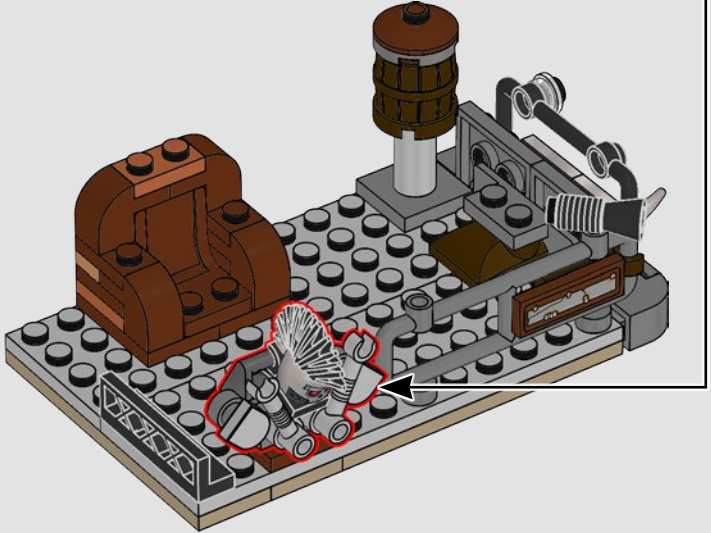
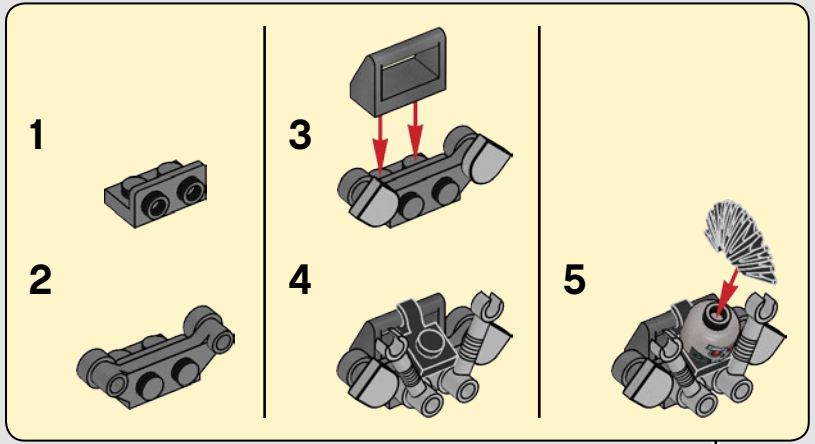

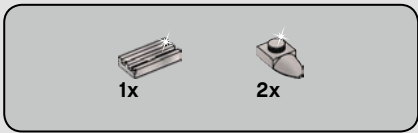

558

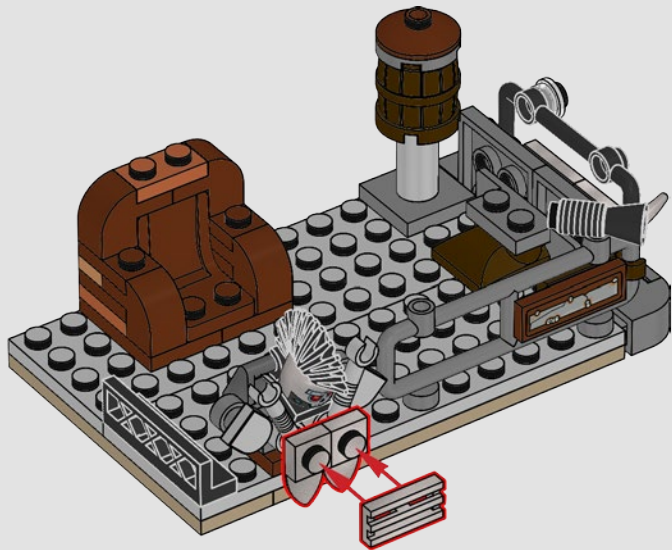

559

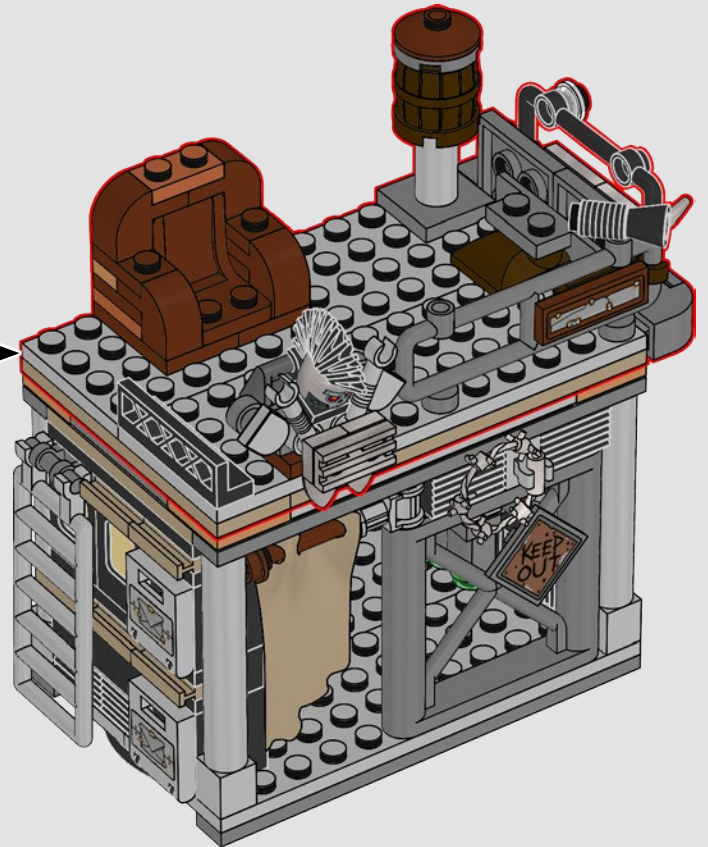

560

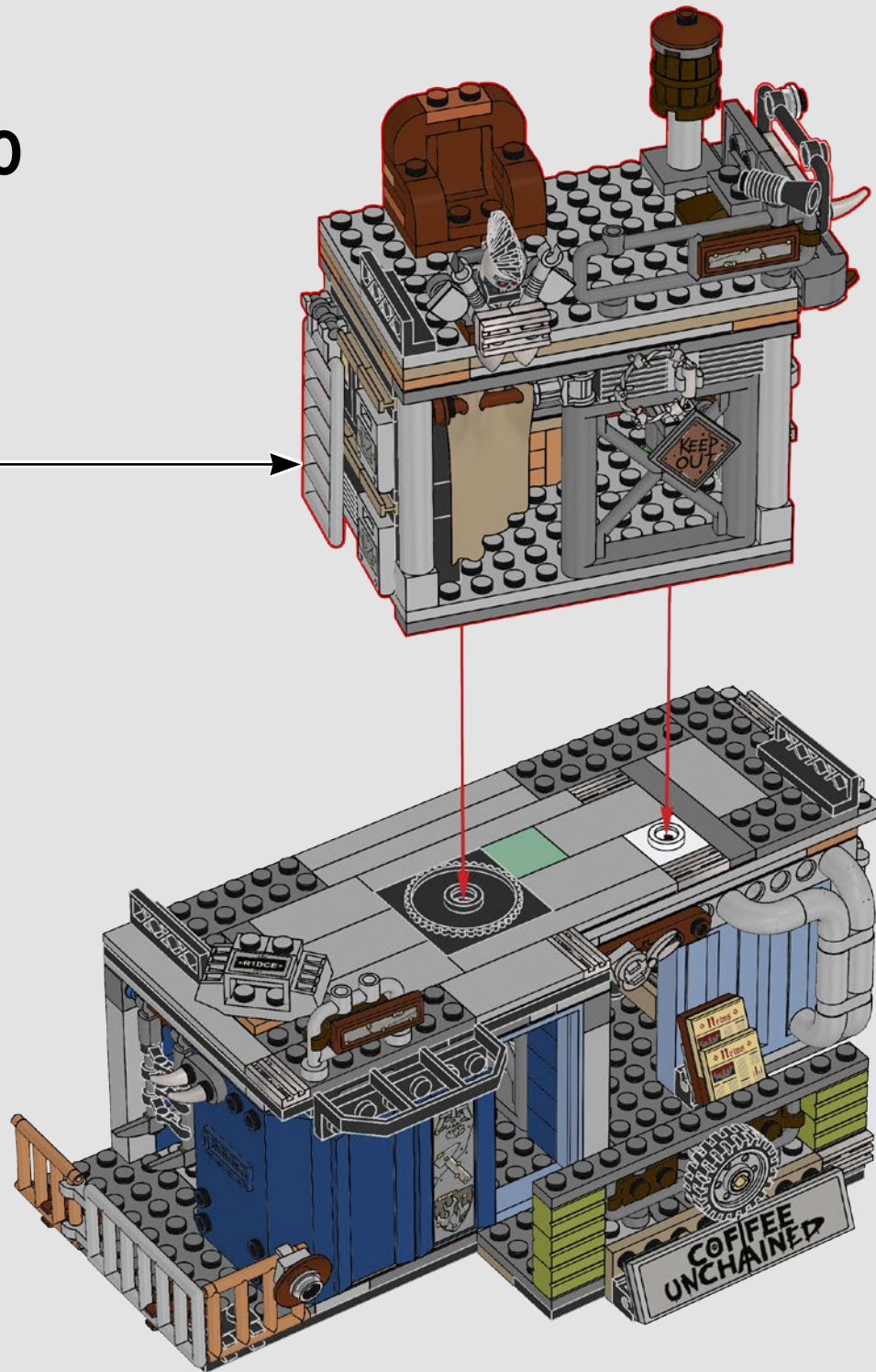

561

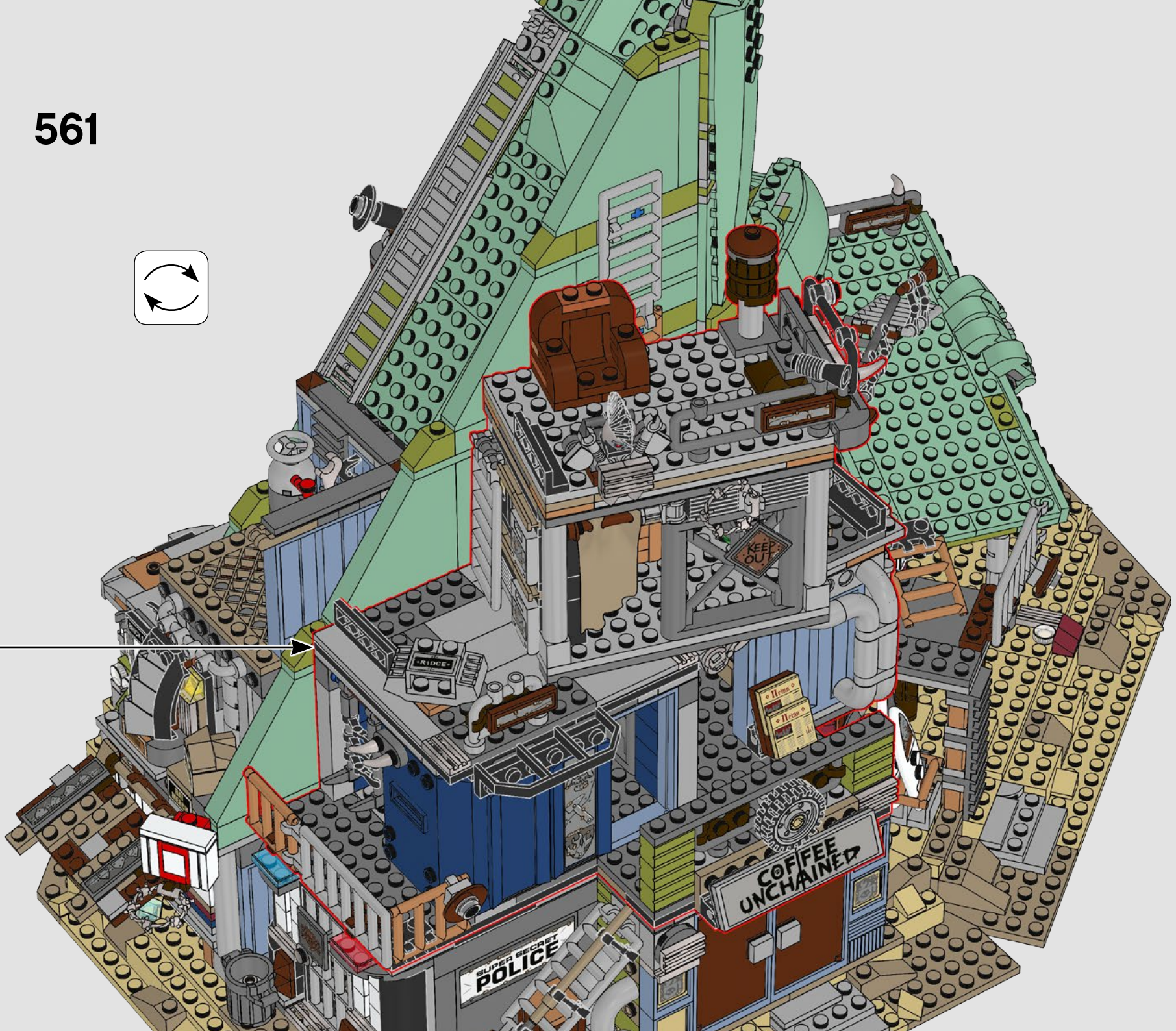
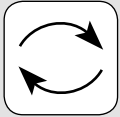

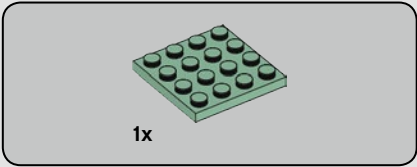
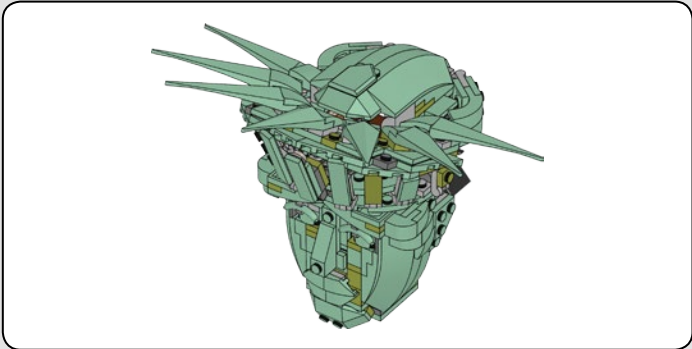
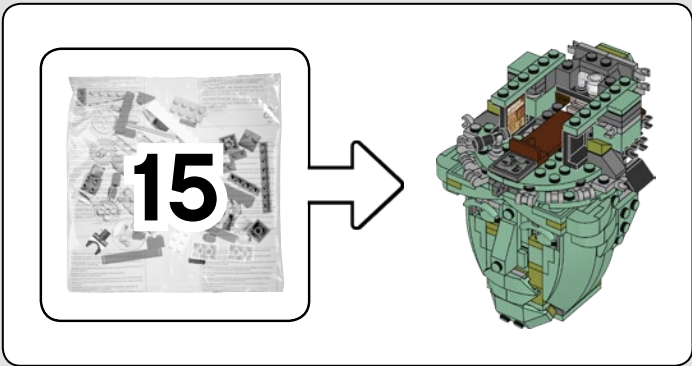

**562**

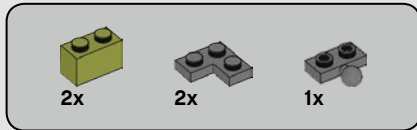
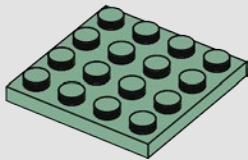

**563**

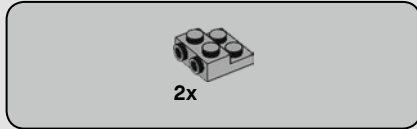
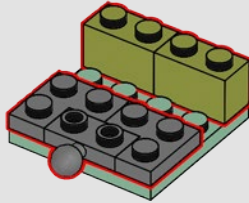

**564**

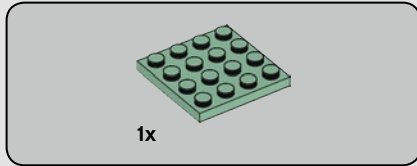
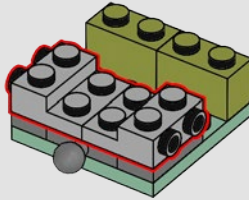

**565**

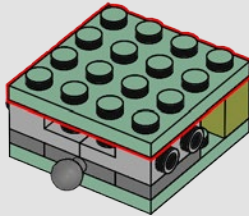

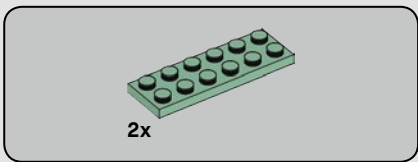

566

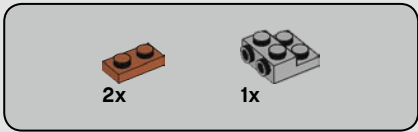
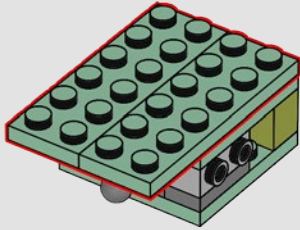

567

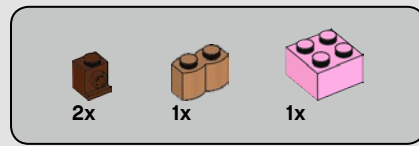
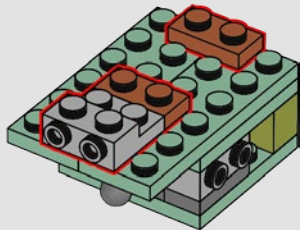

568

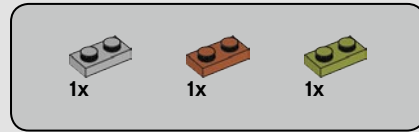
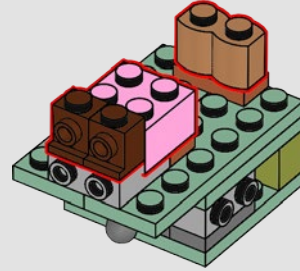

569

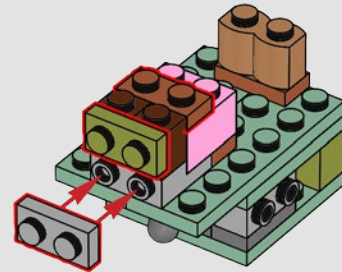

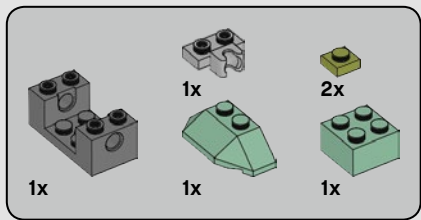

570

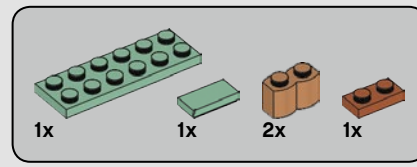
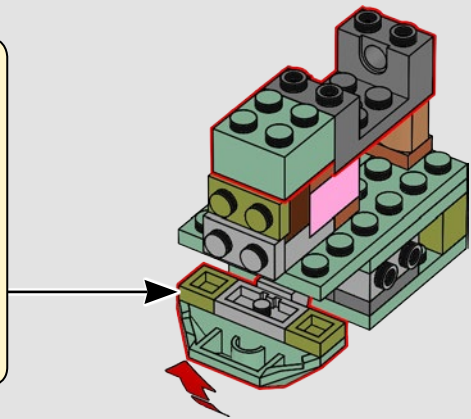
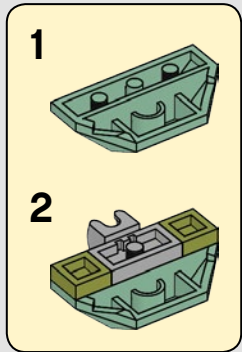

571

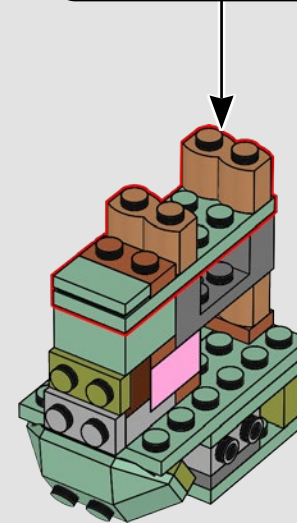
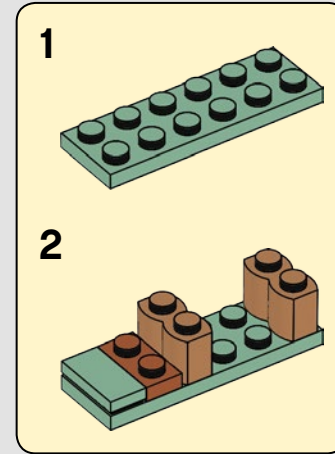



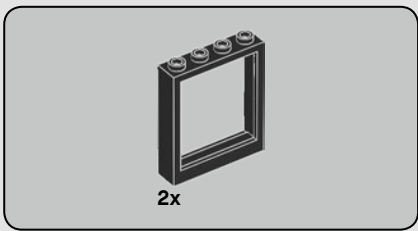

572

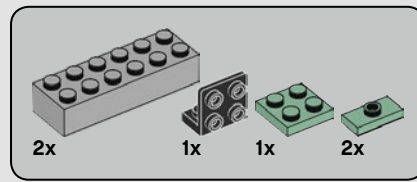
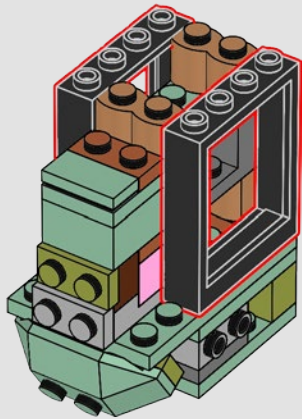

573

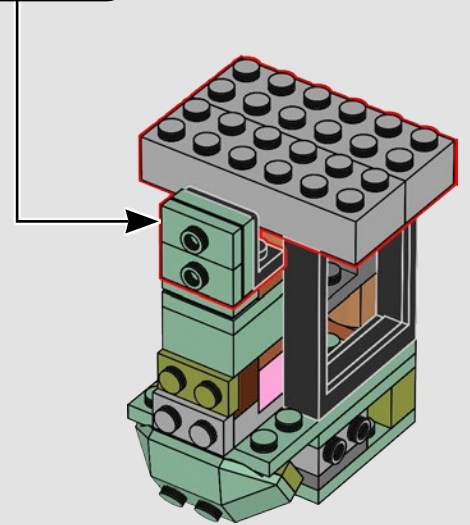
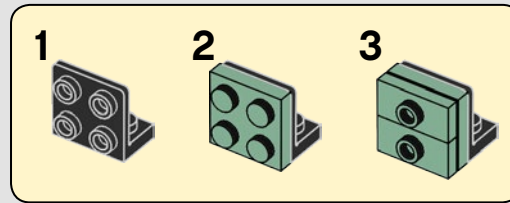

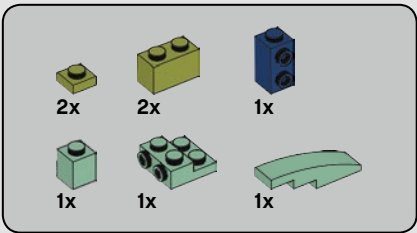

# 574

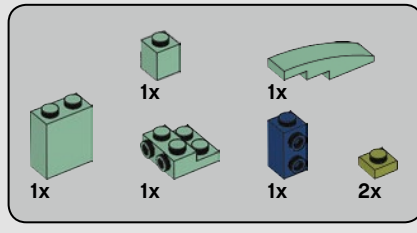
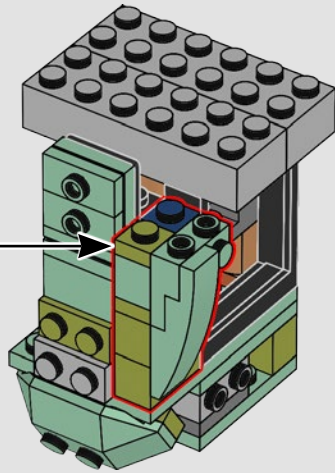
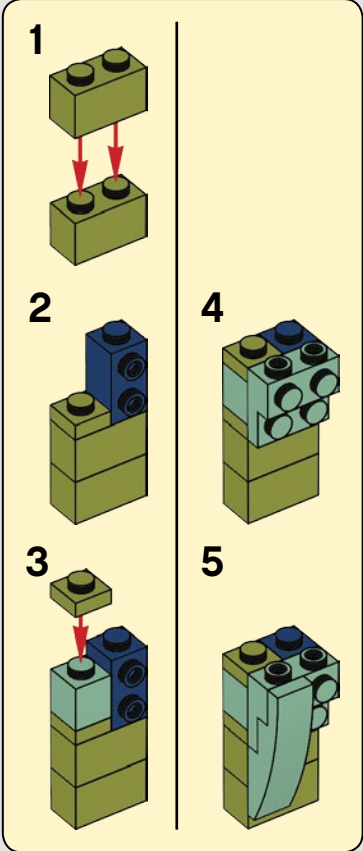

# 575

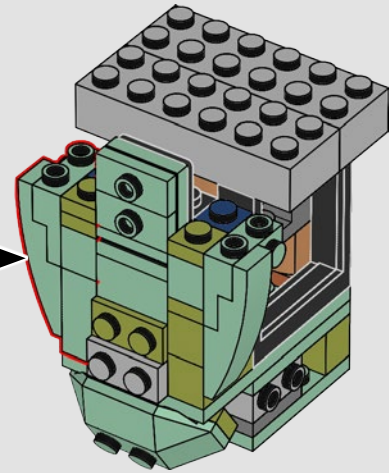
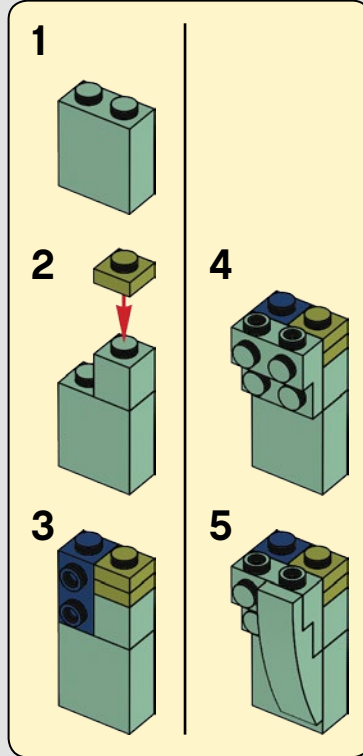

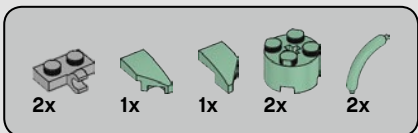

576

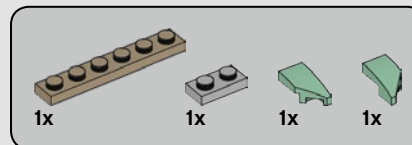
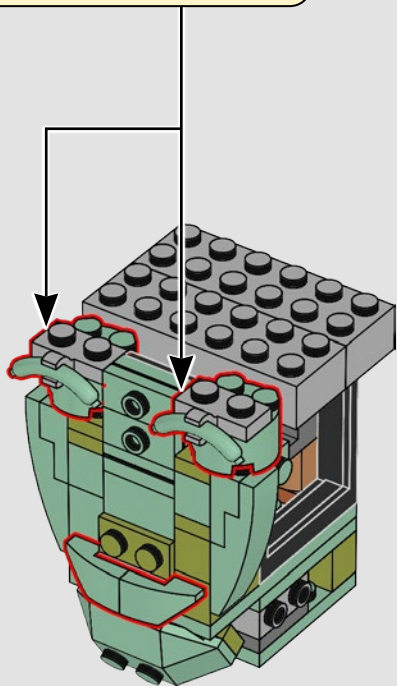

577

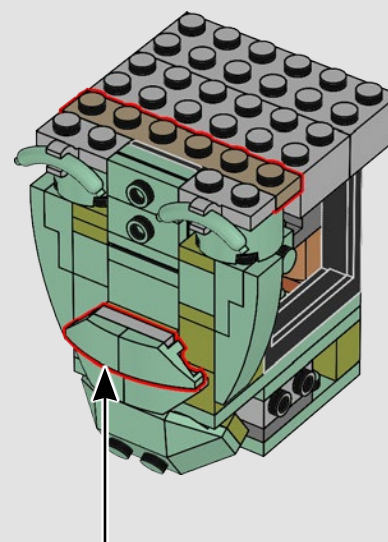
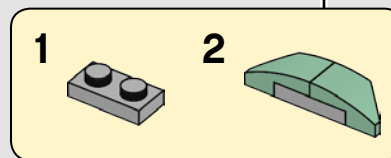

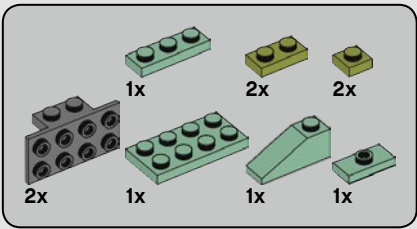

# 578

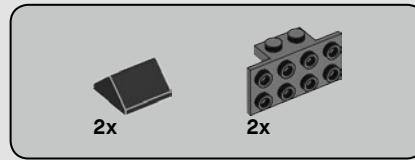
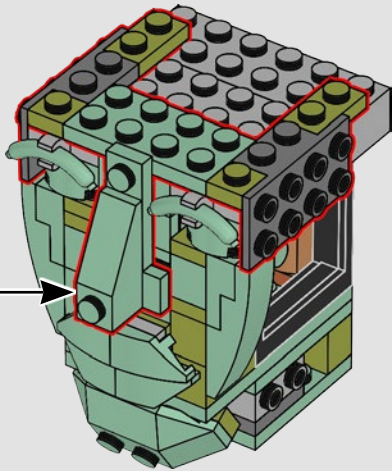
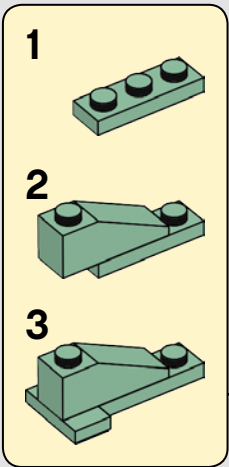

# 579

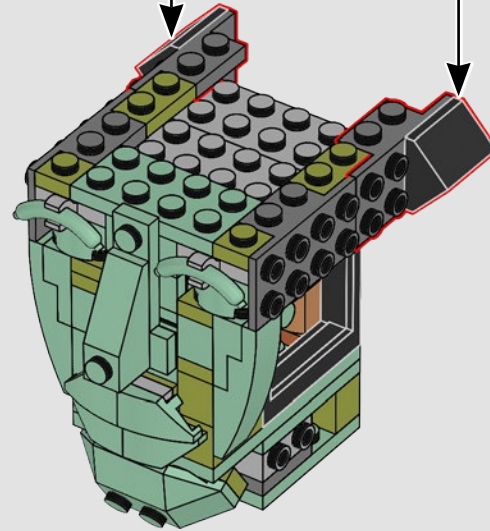
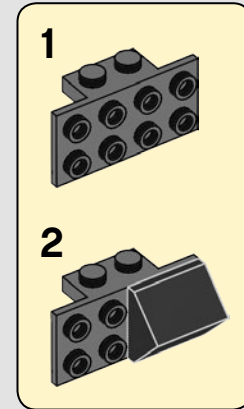
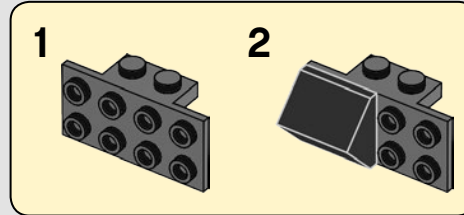

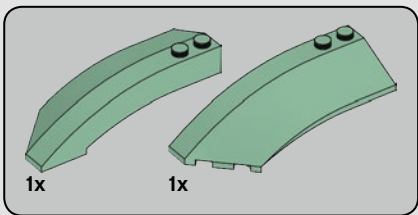

580

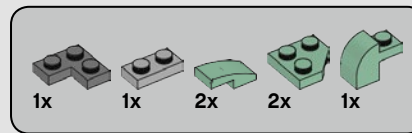
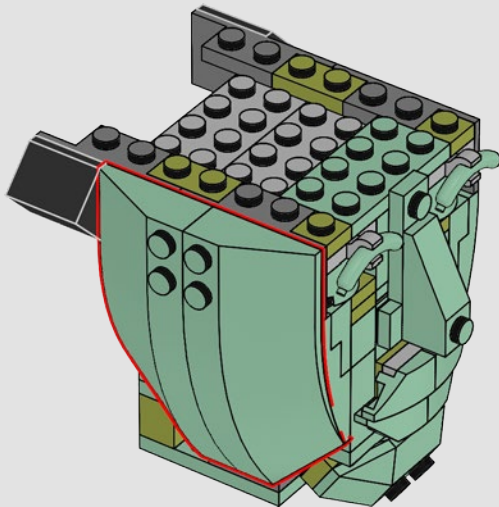
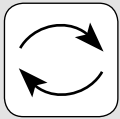

581

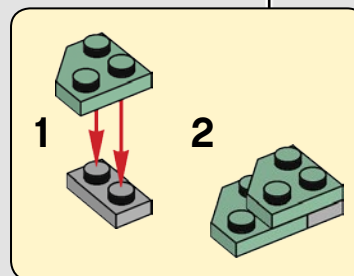
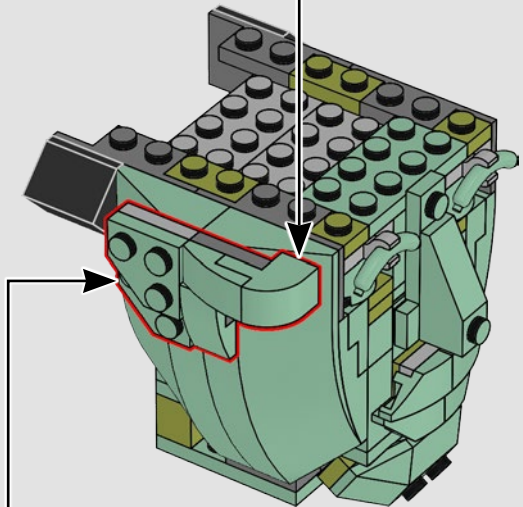
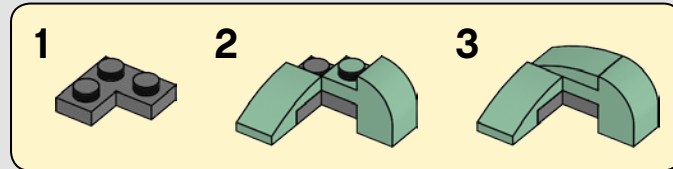

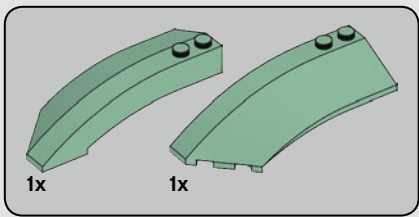

582

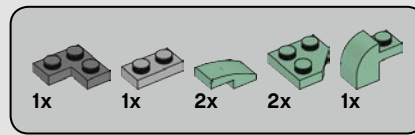
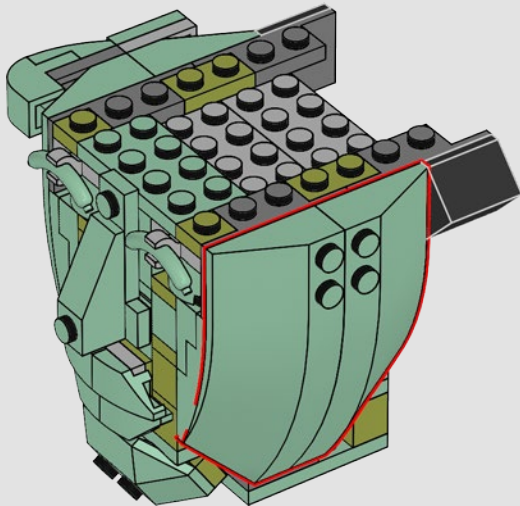
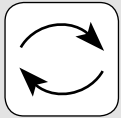

583

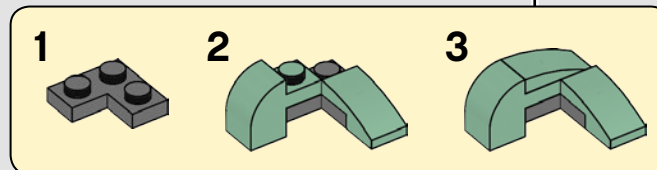
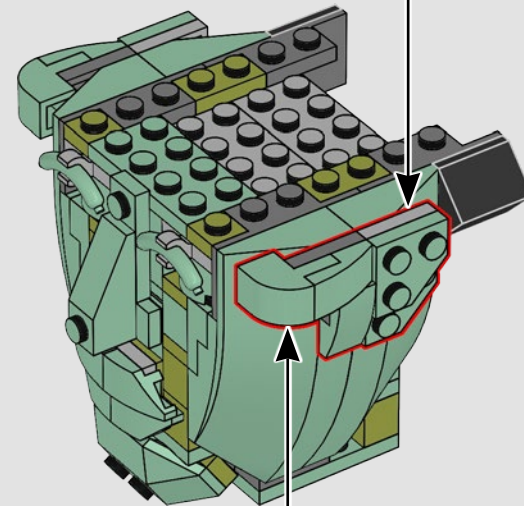
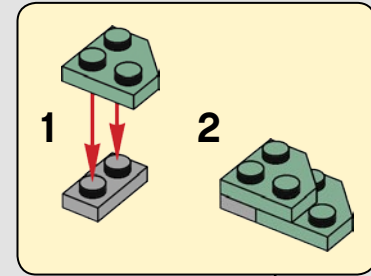

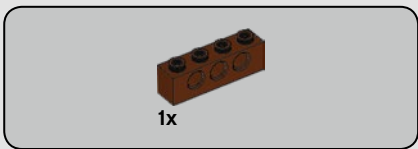

584

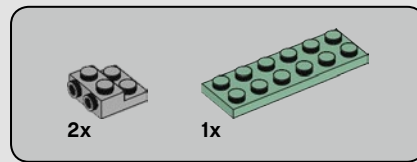
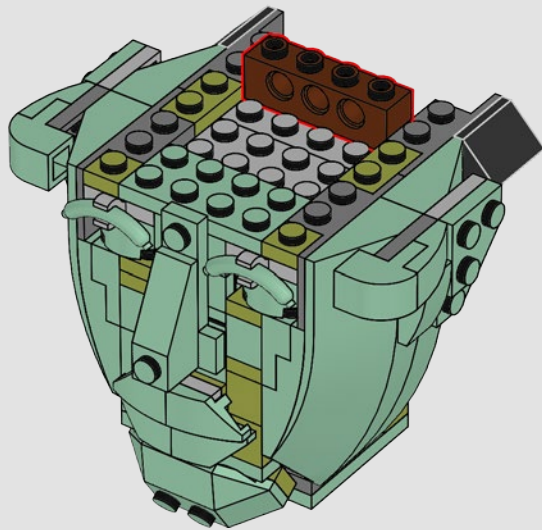

585

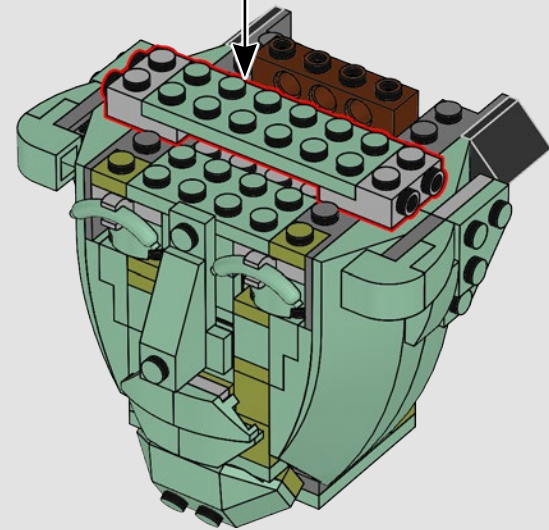
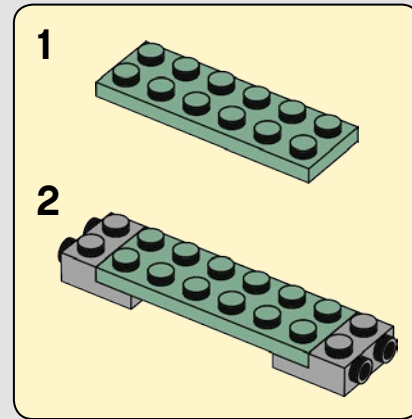

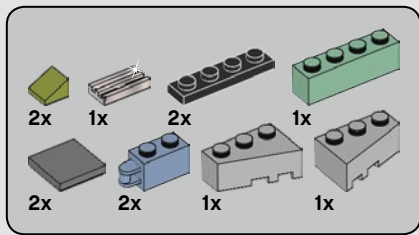

586

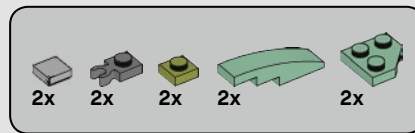
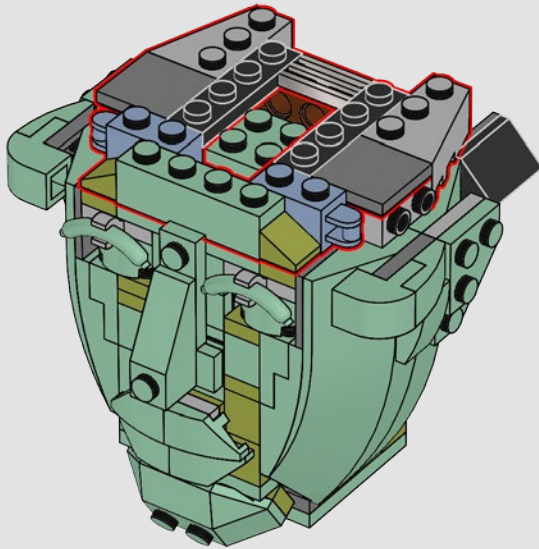

587

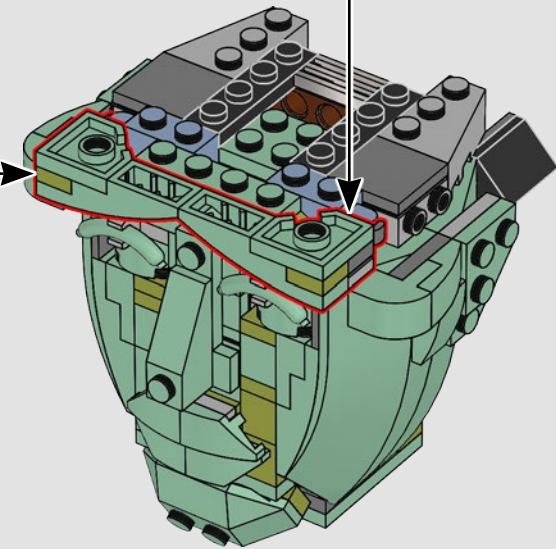
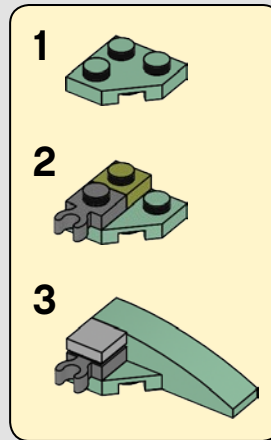
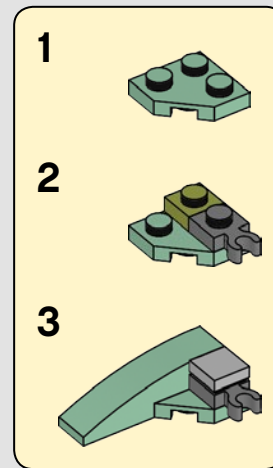



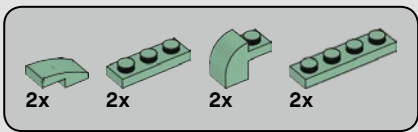

588

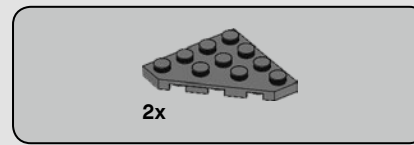
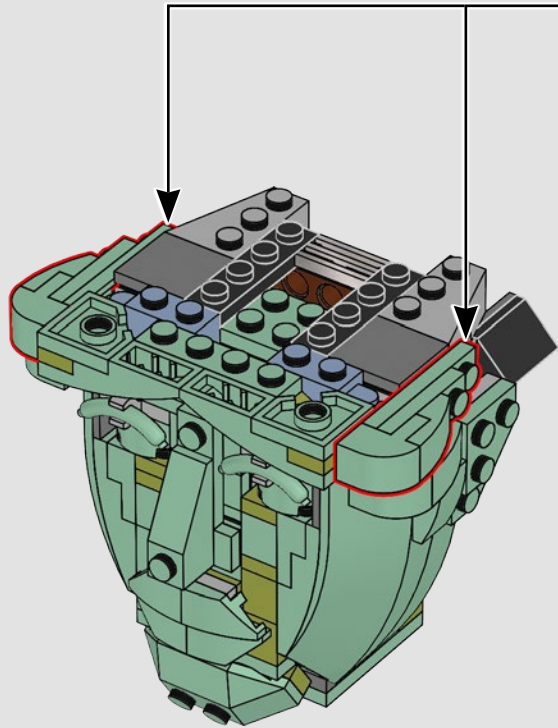
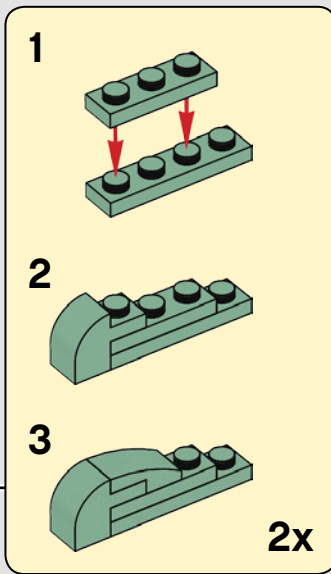

589

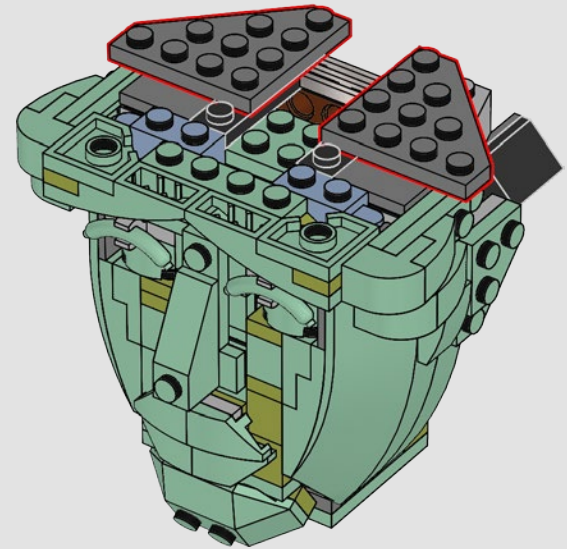

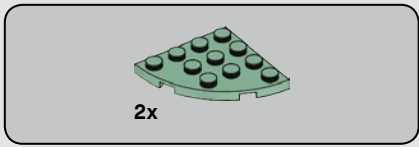

590

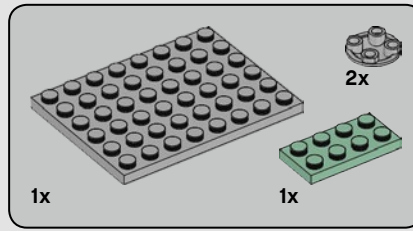
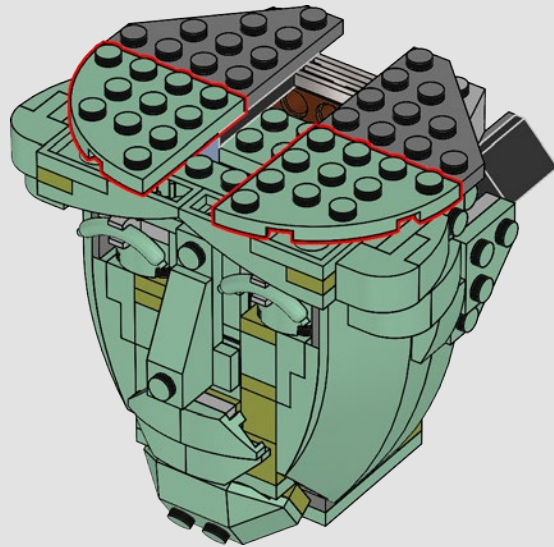

591

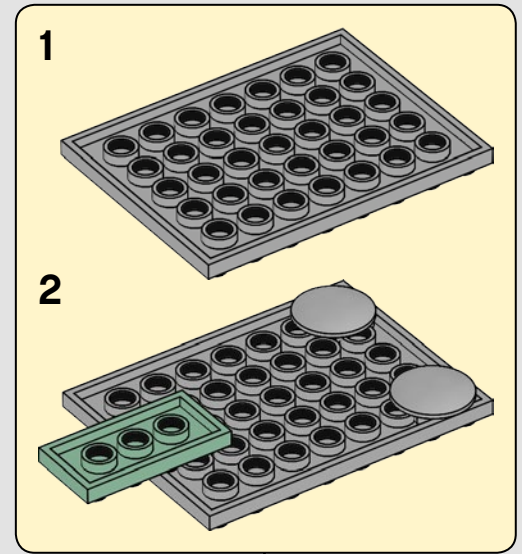
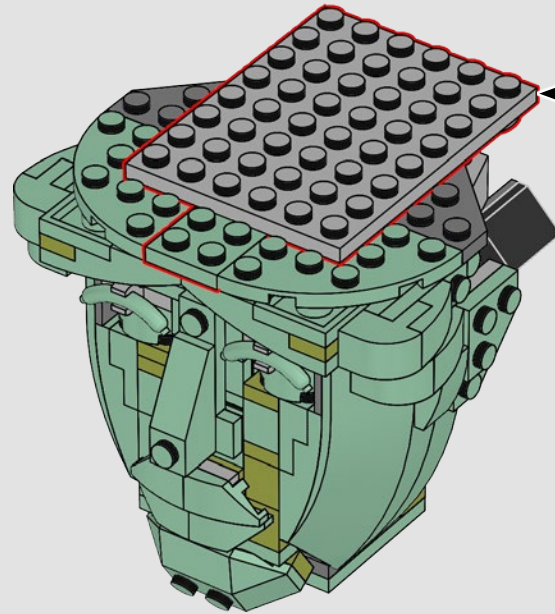

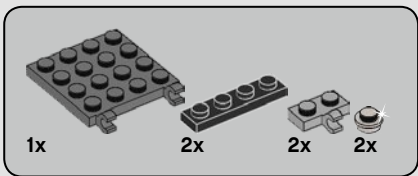

592

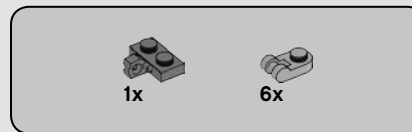
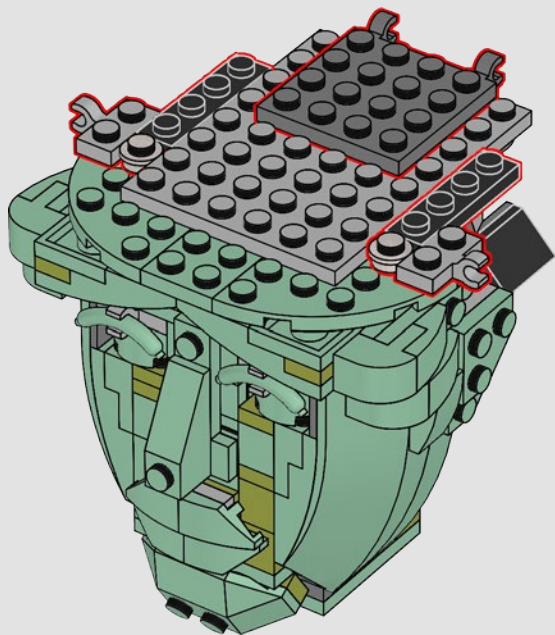

593

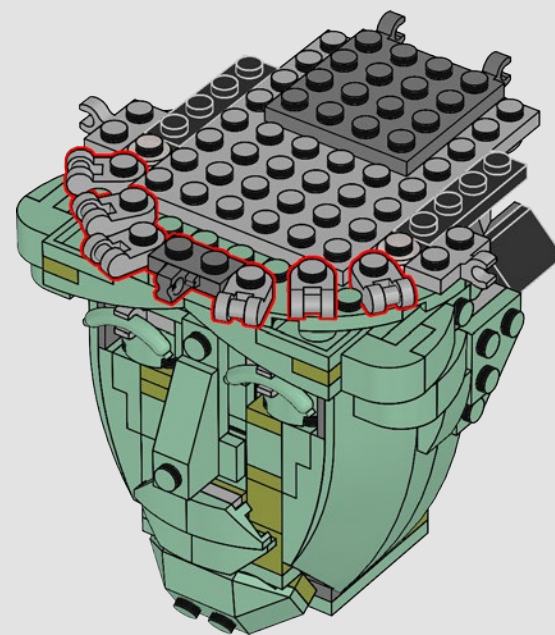

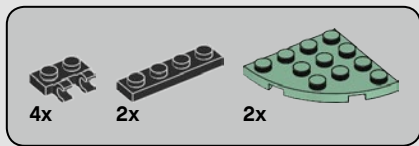

594

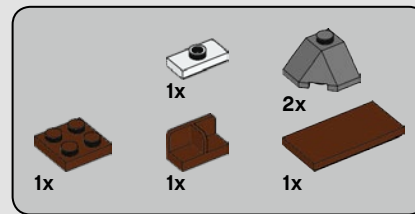
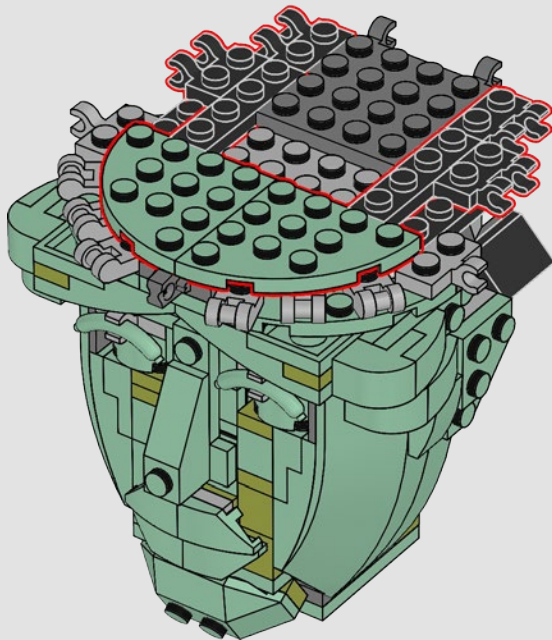

595

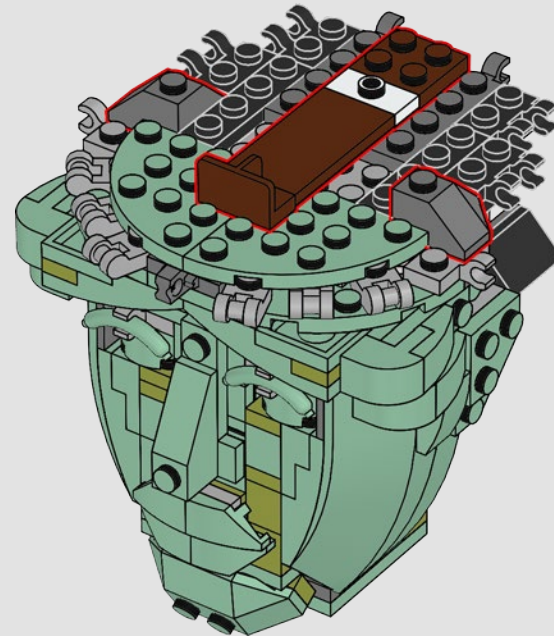

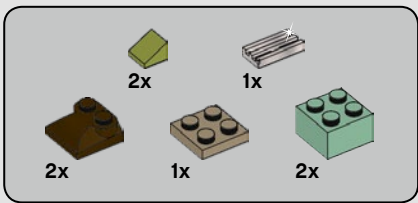

596

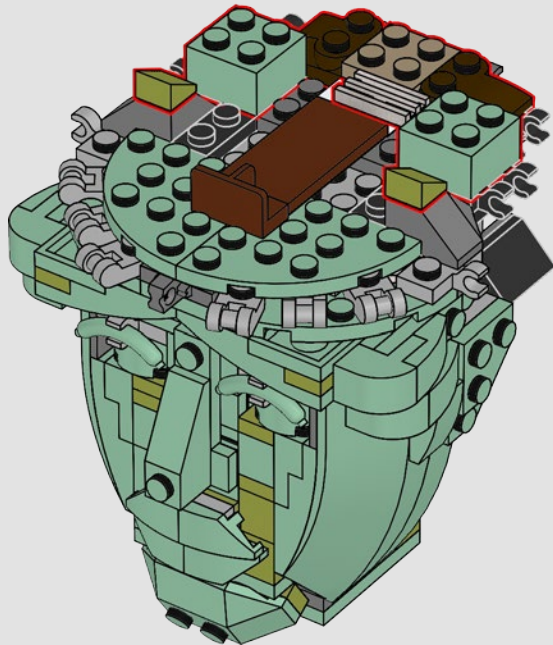

597

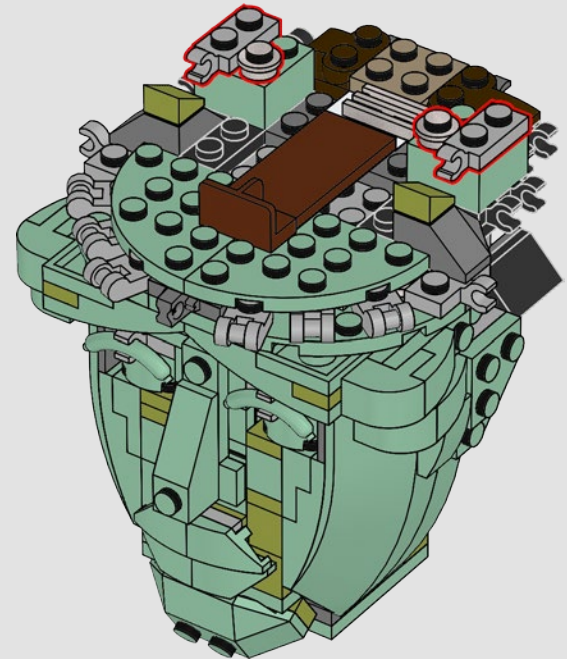

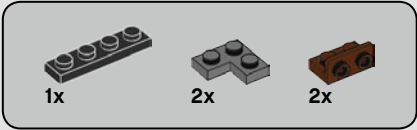

# 598

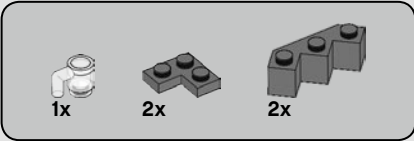
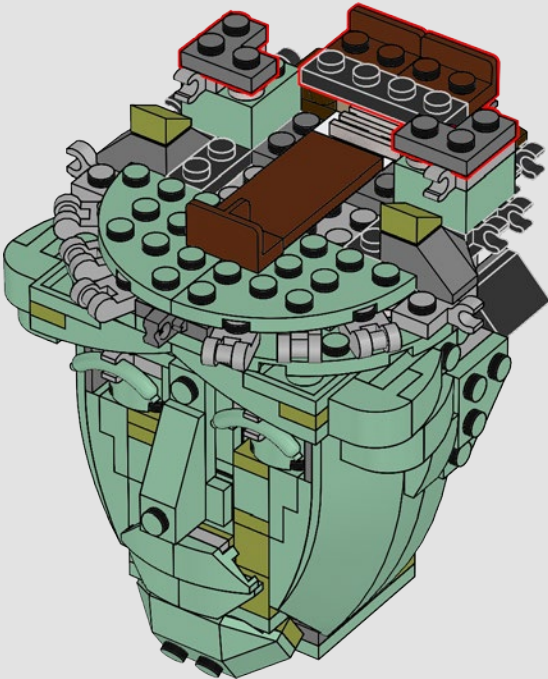

# 599

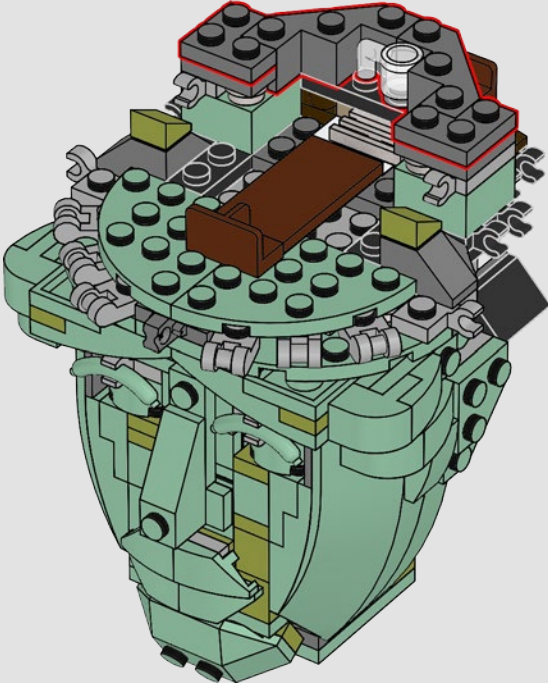

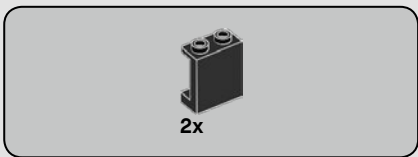

# 600

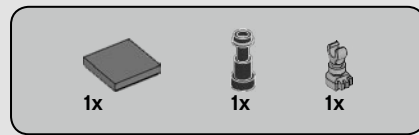
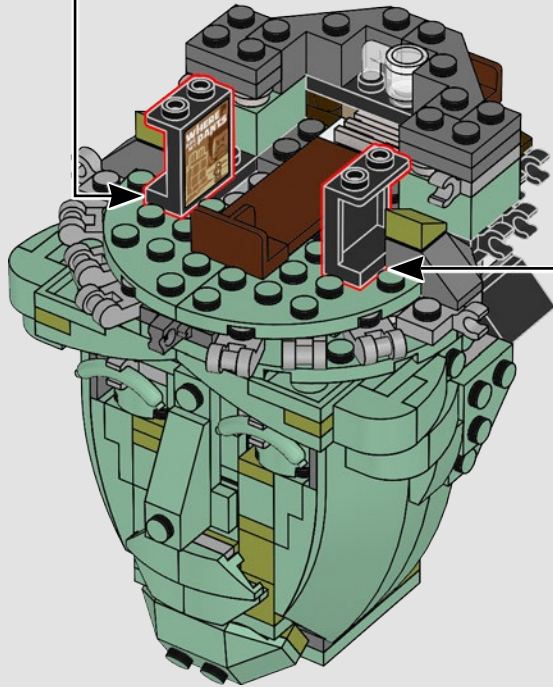
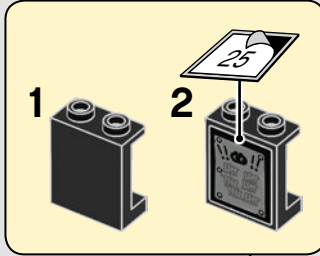
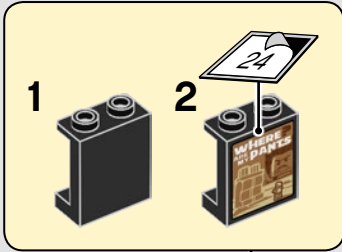

# 601

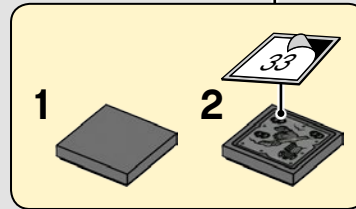
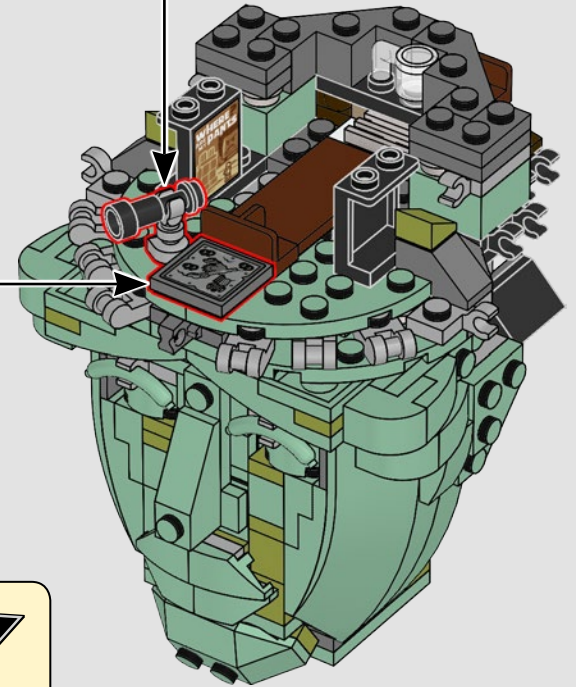
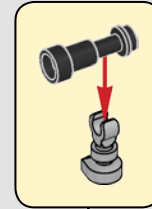

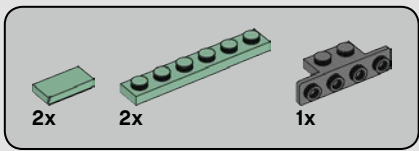

602

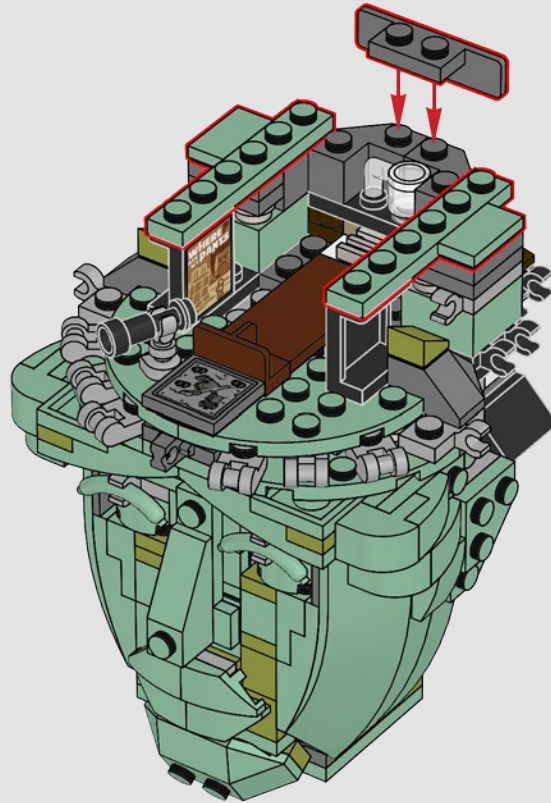



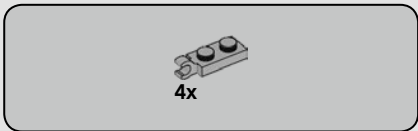

603

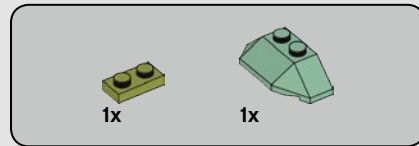
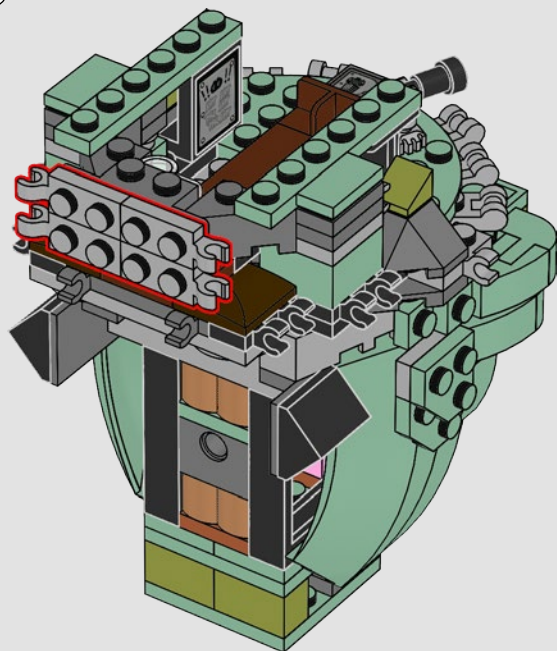
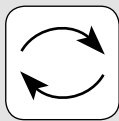

604

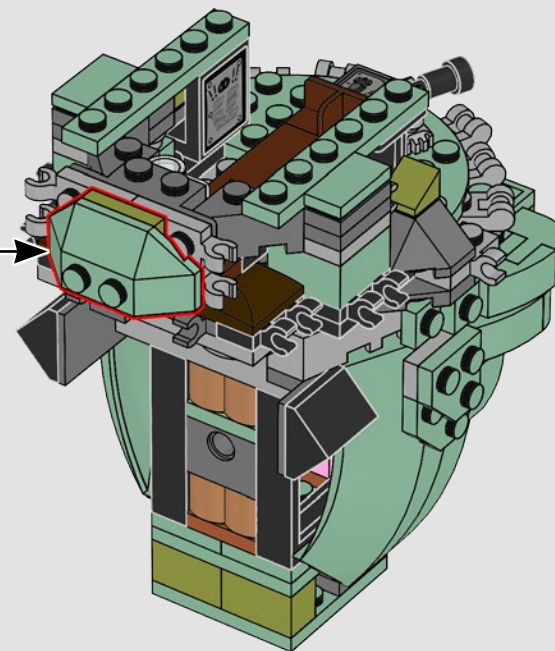
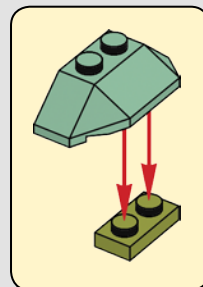

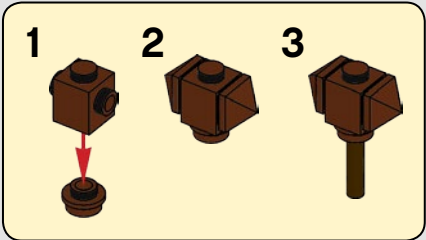
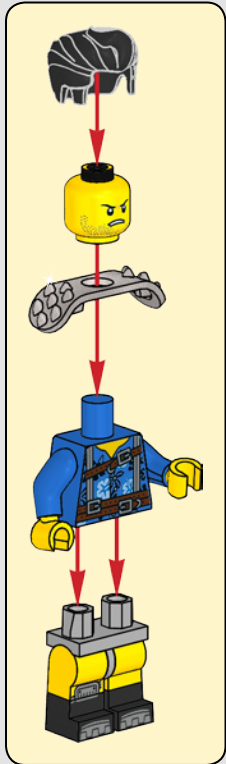
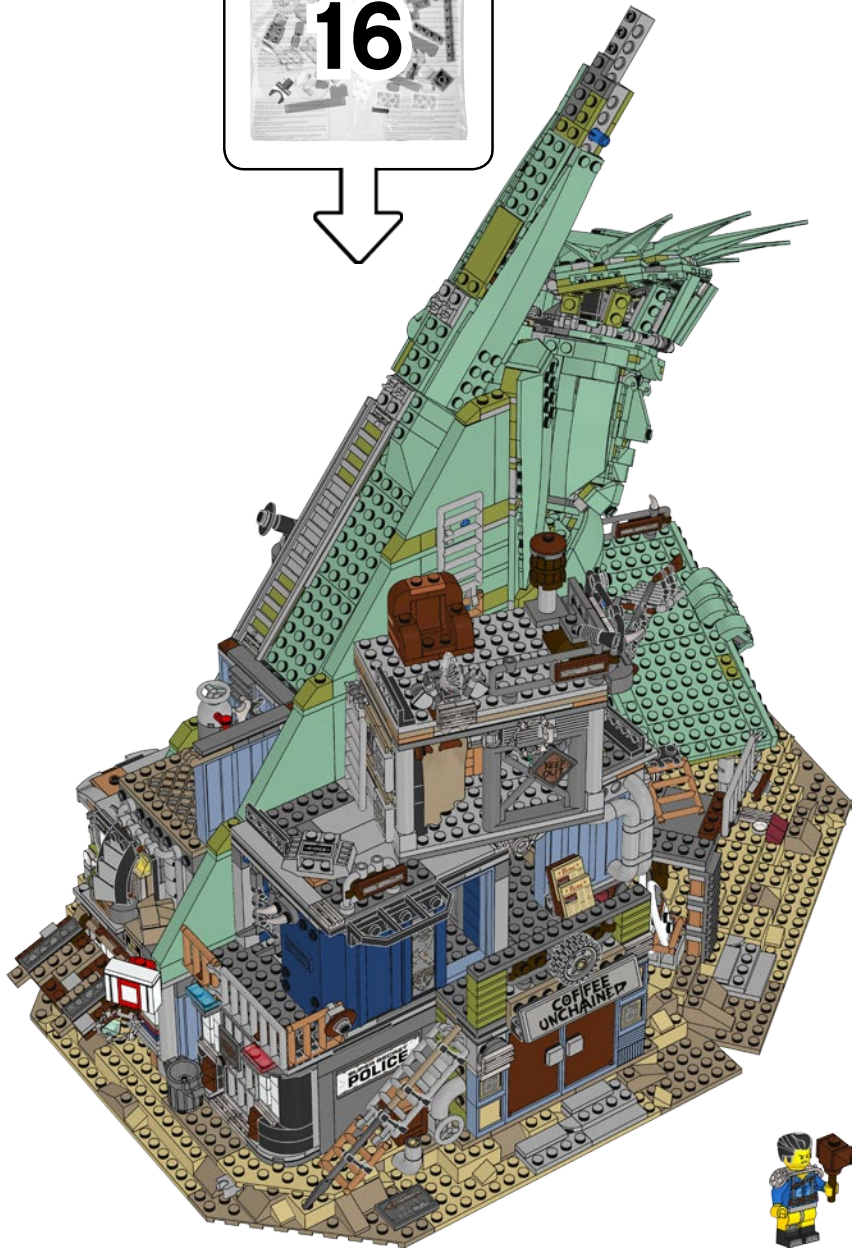
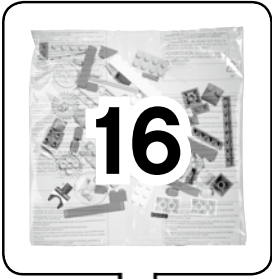

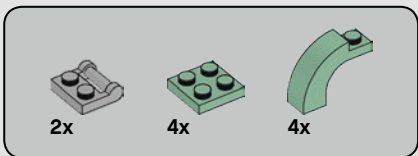

# 605

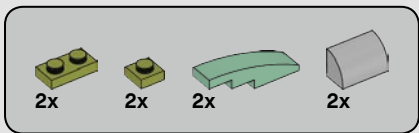
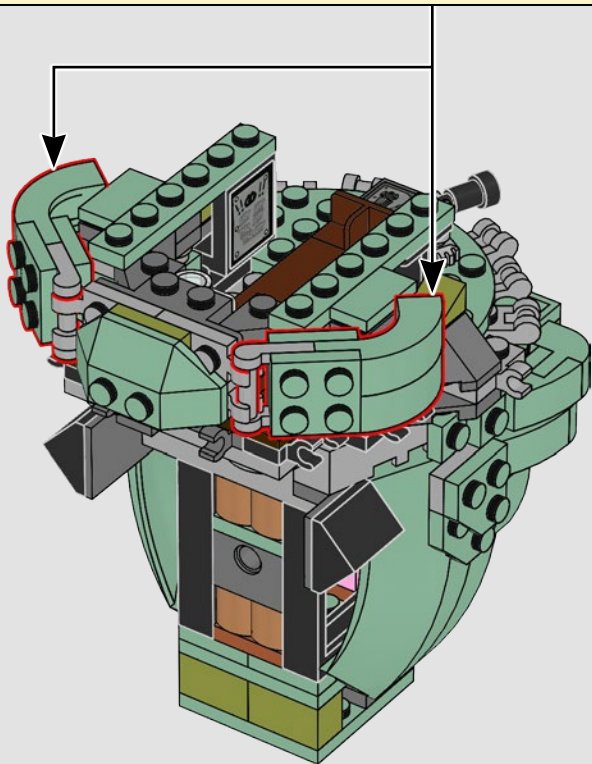
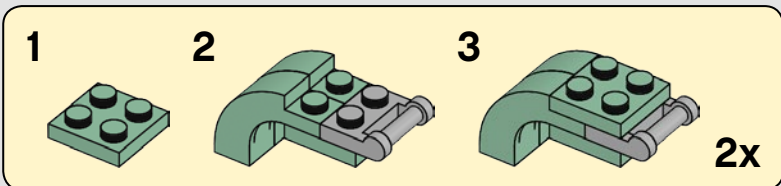

# 606

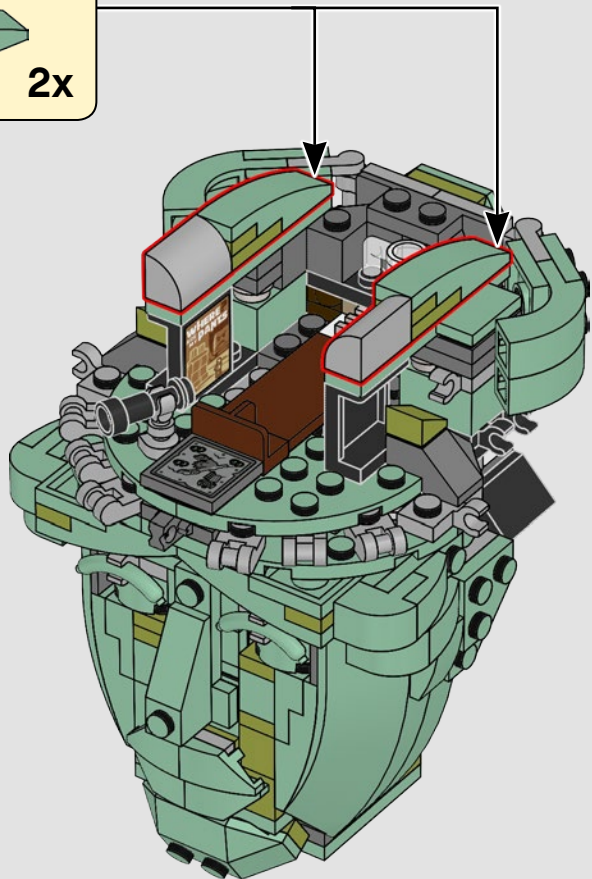
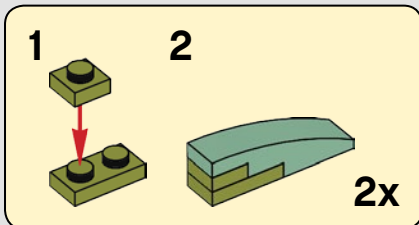
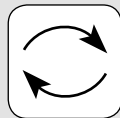

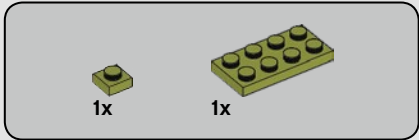
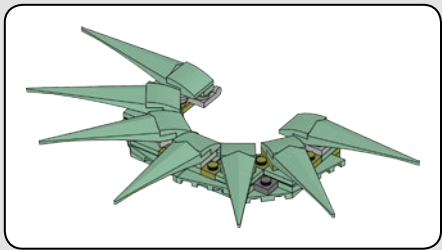

607

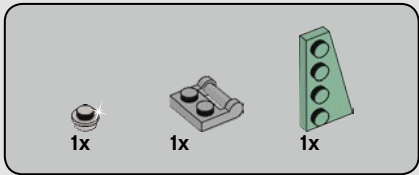
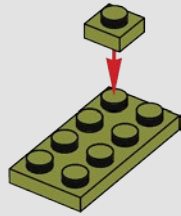

608

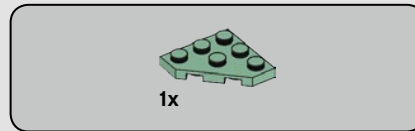
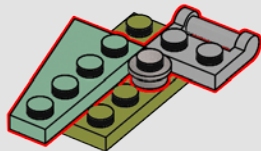

609

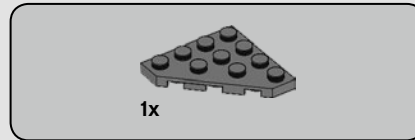
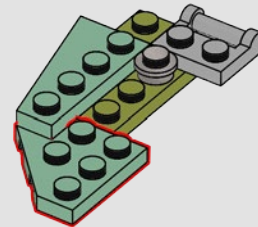

610

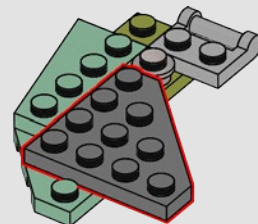

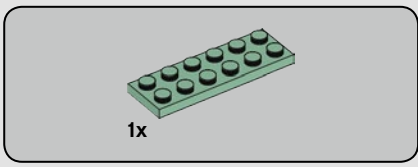

611

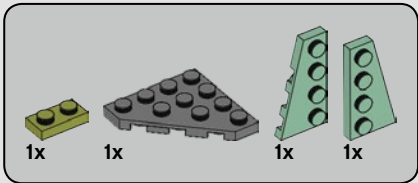
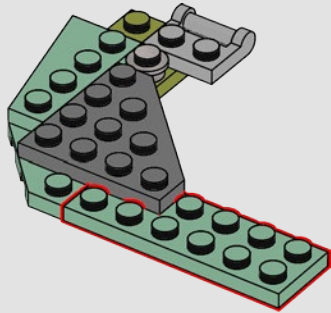

612

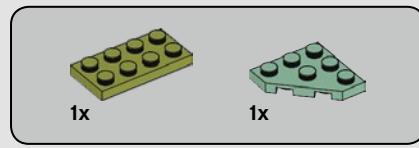
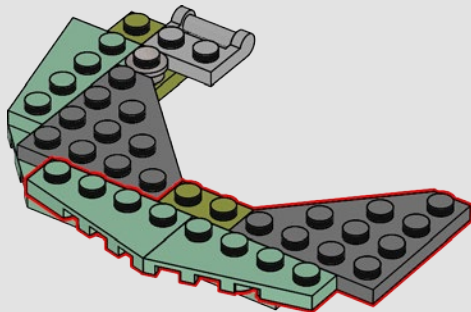

613

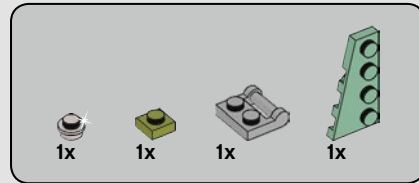
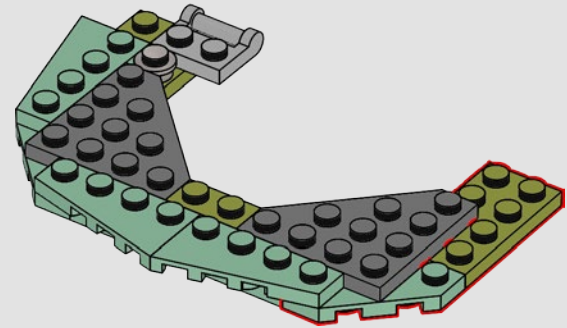

614

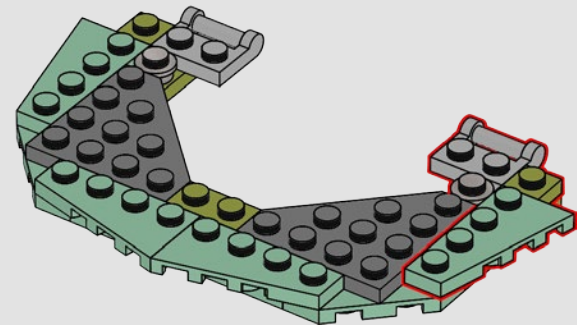

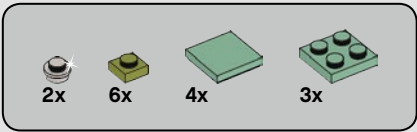

615

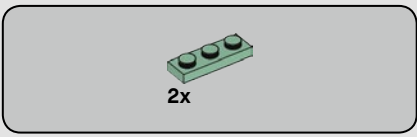
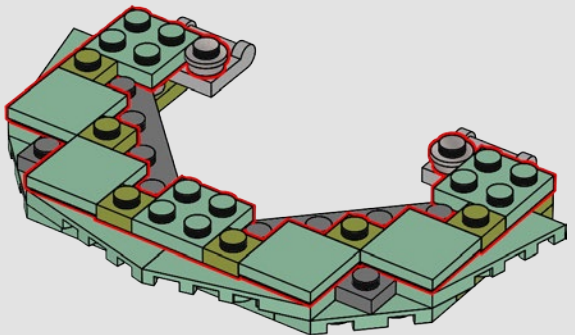

616

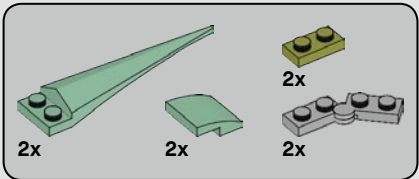
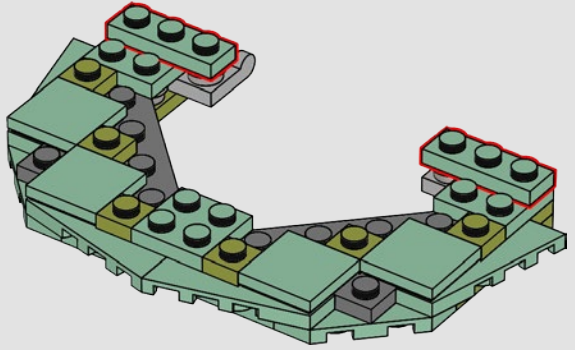

617

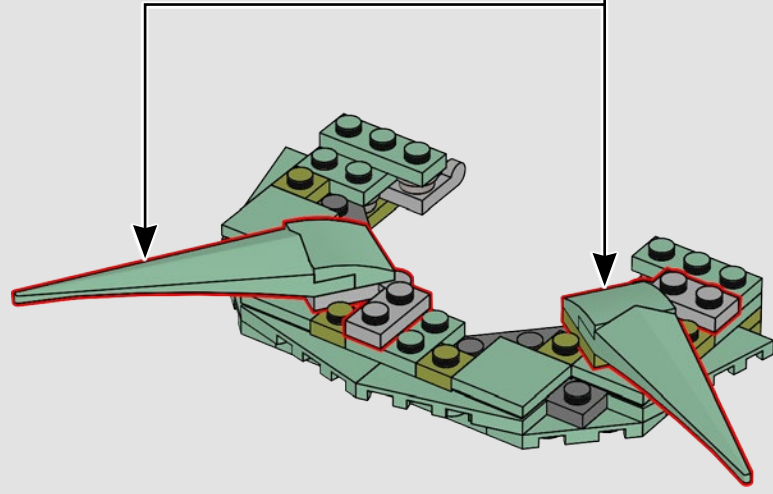
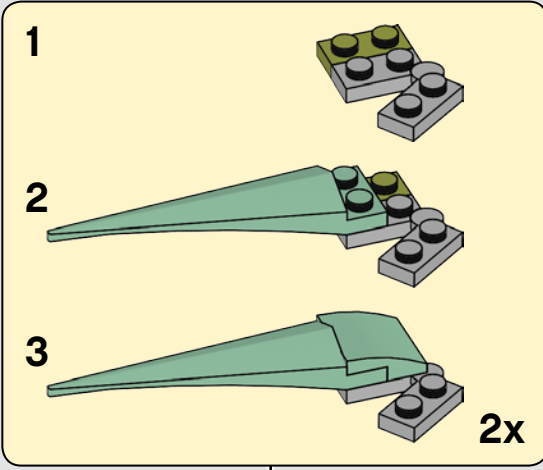

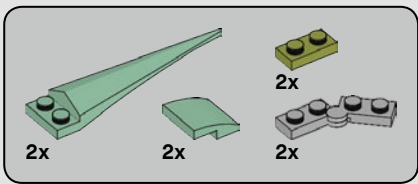

618

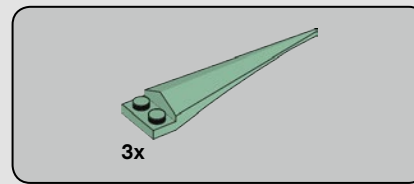
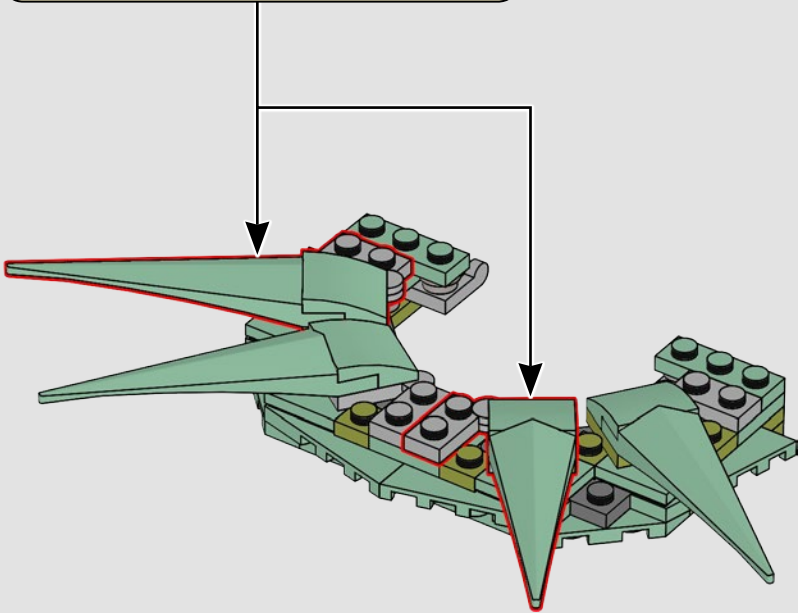
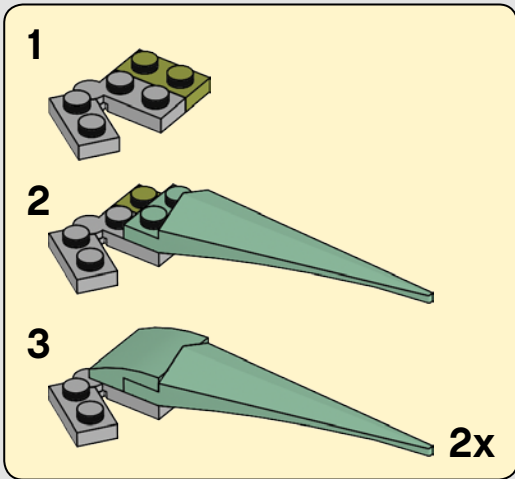

619

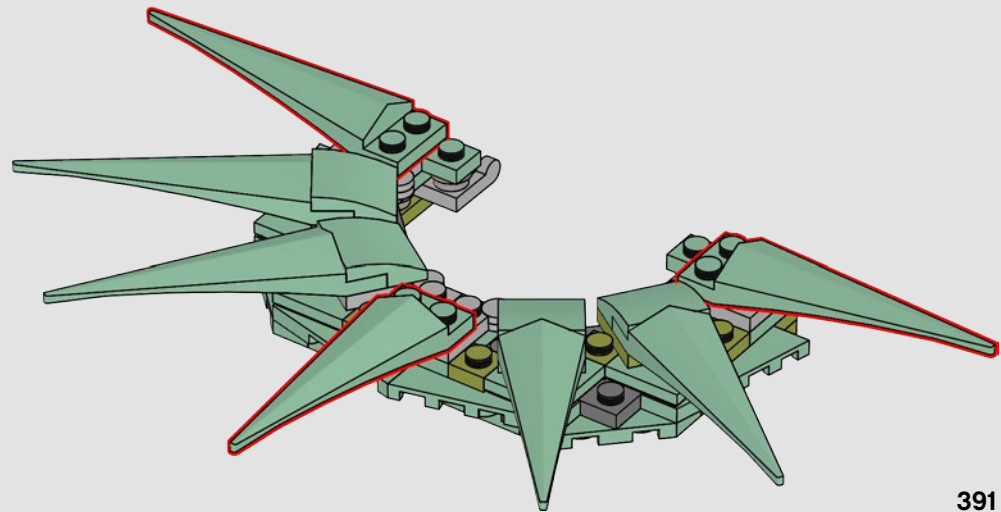

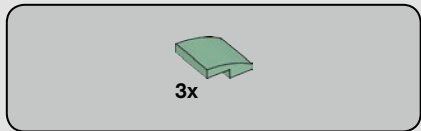

620

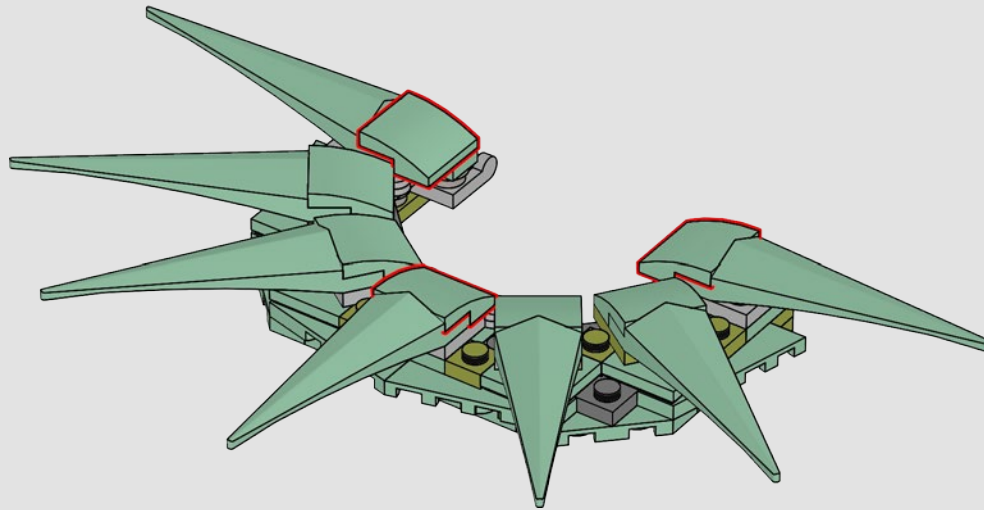

621

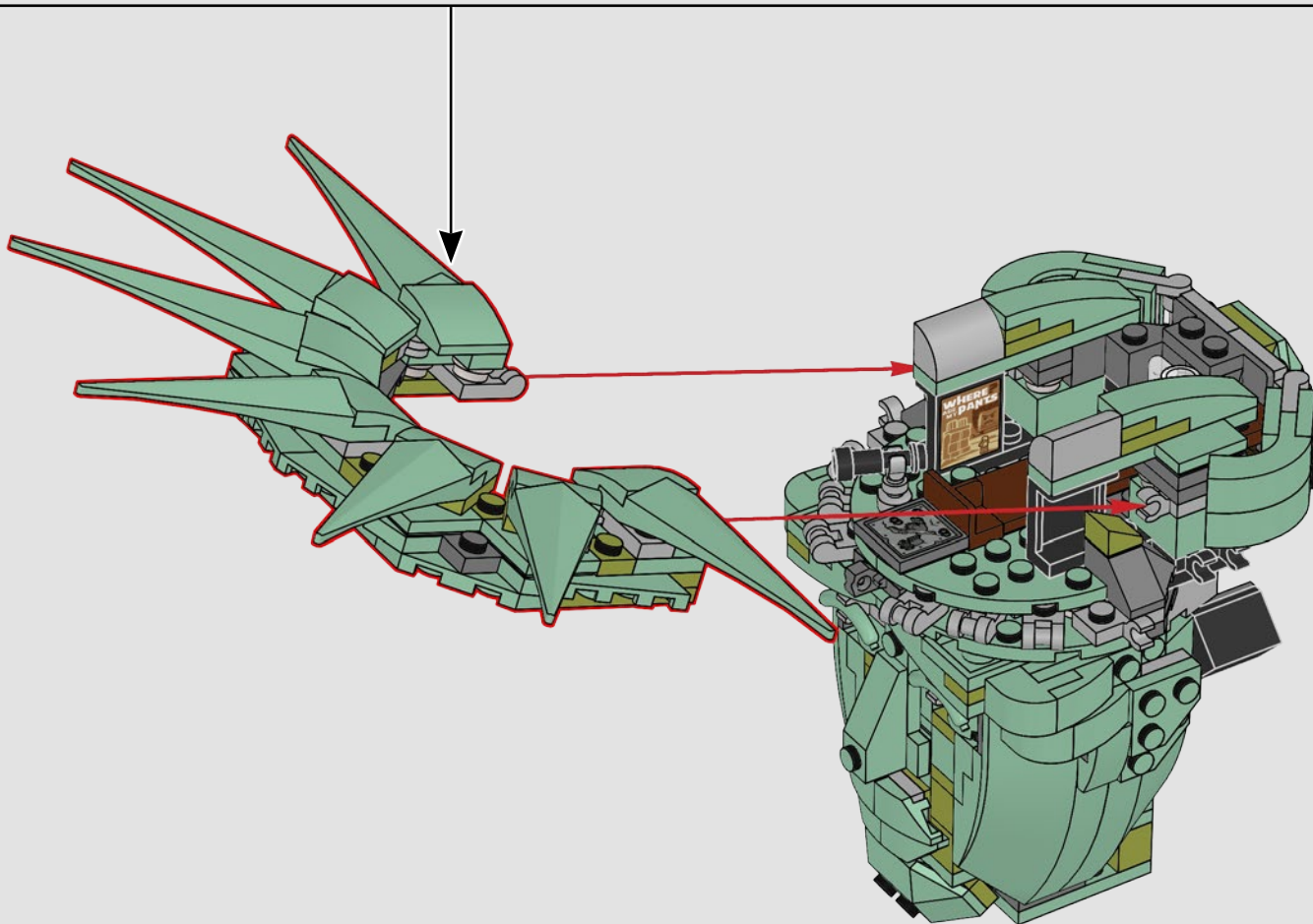



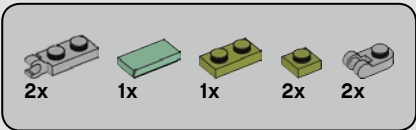

622

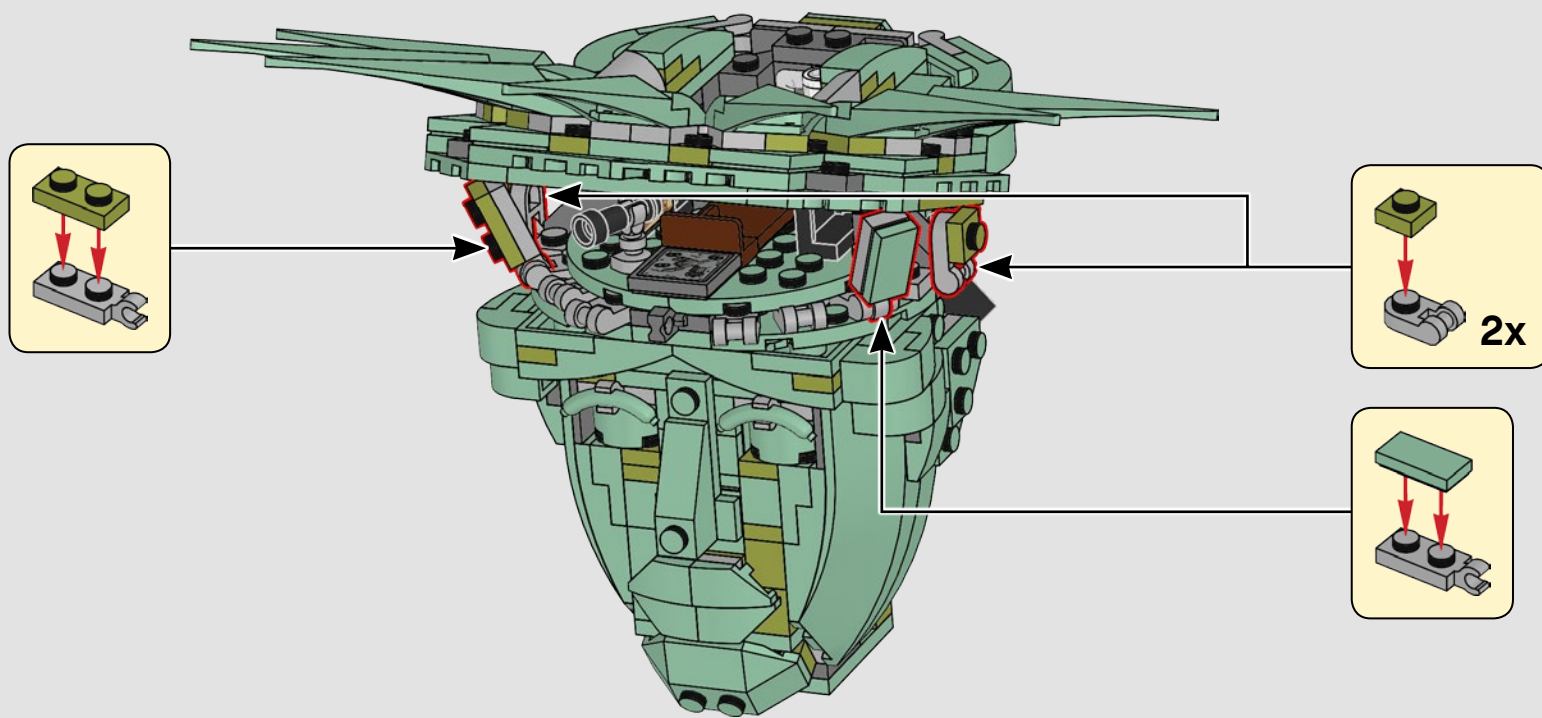

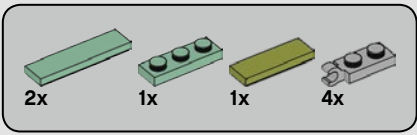

# 623

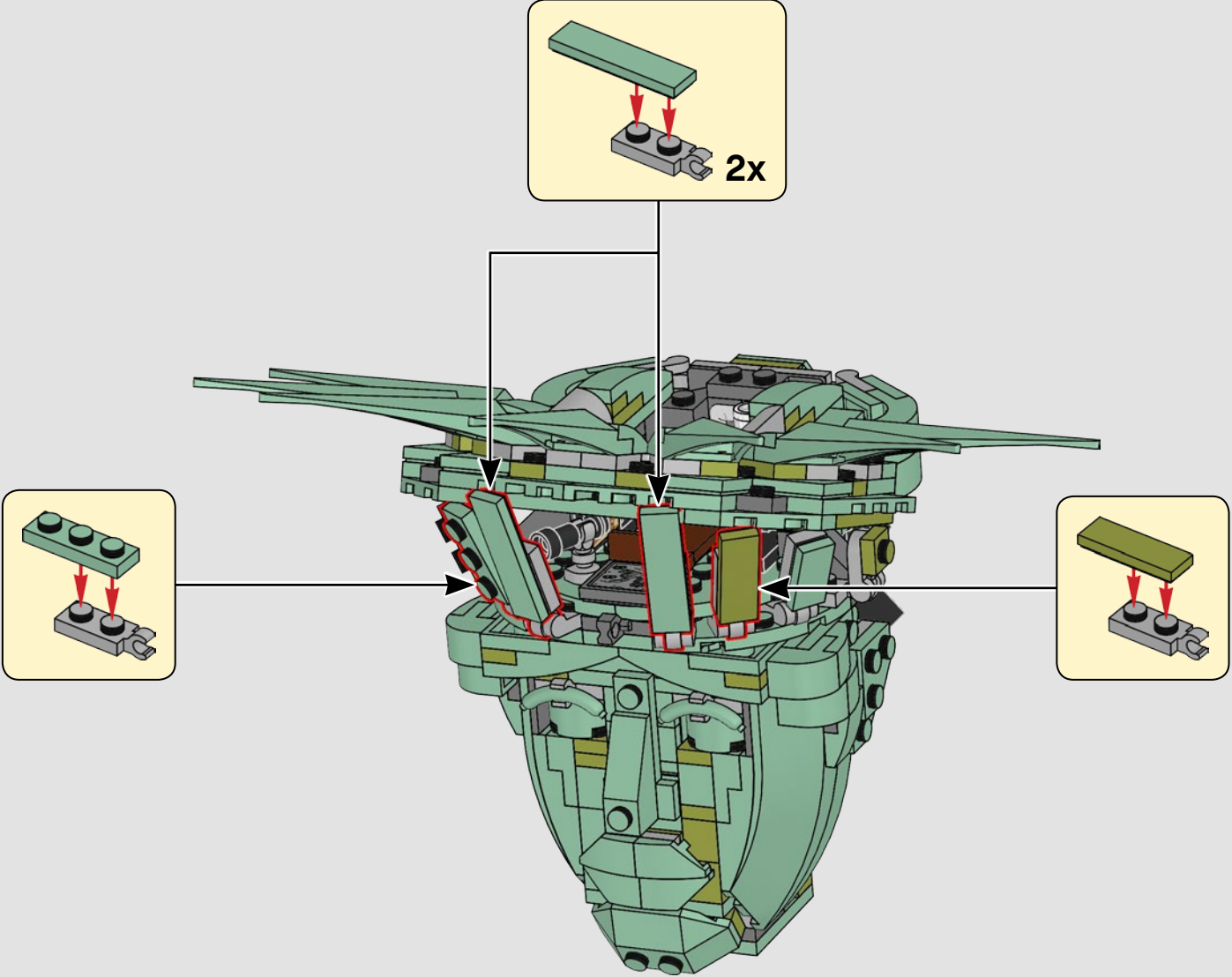

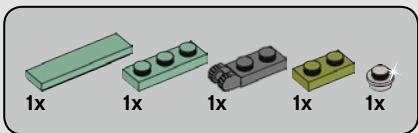

624

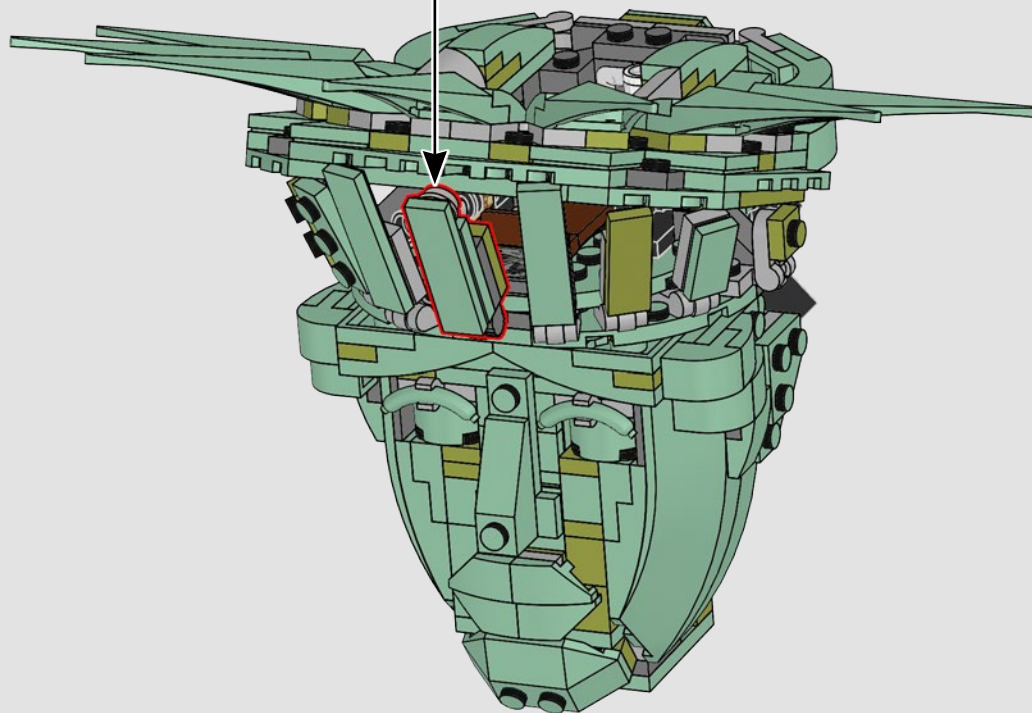
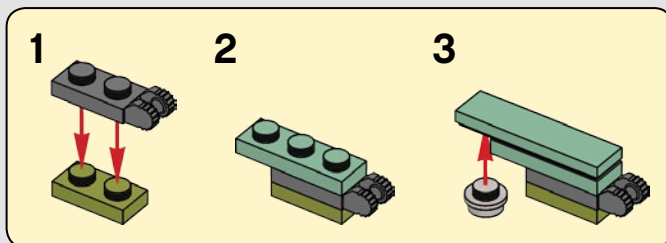

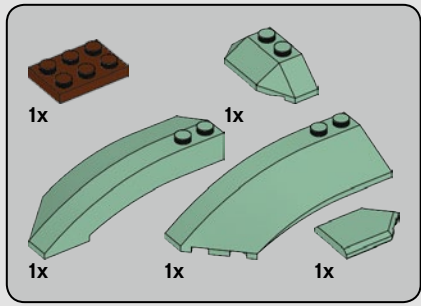

625

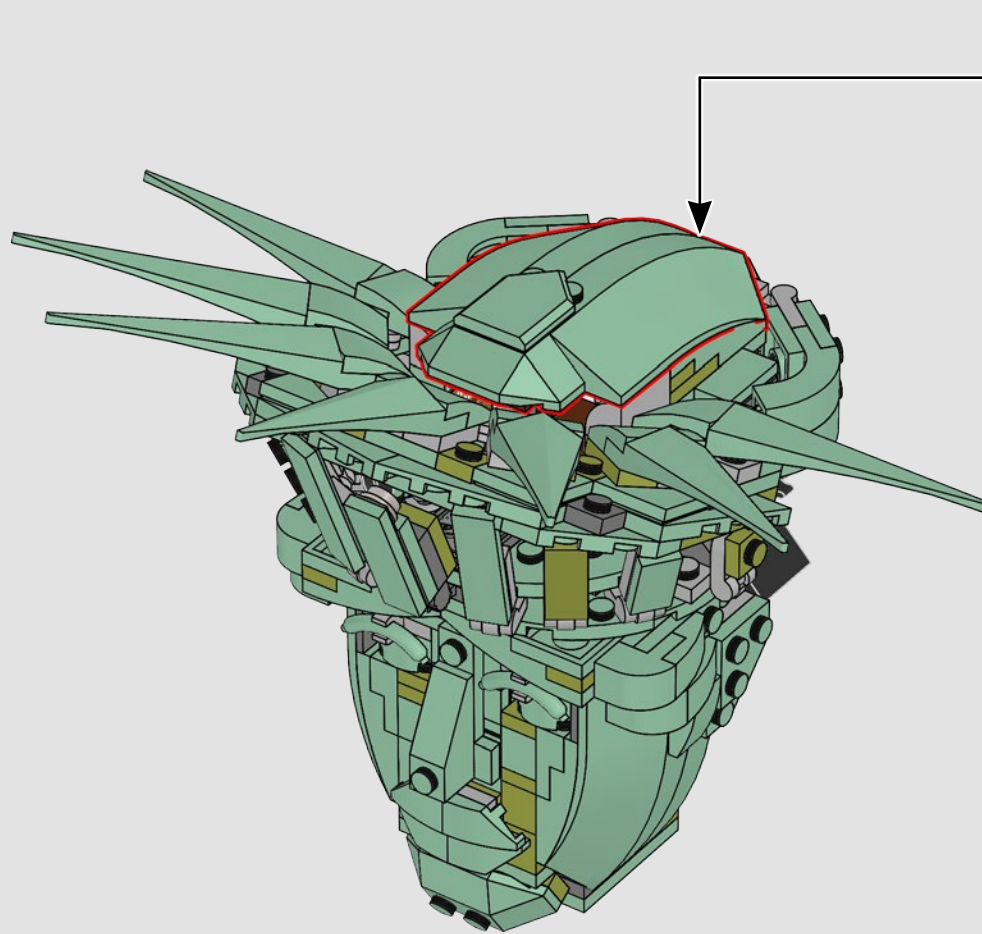
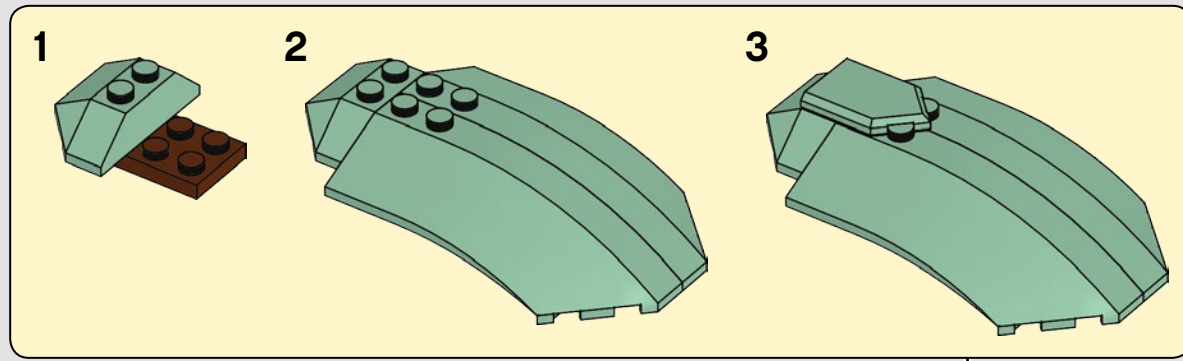



626

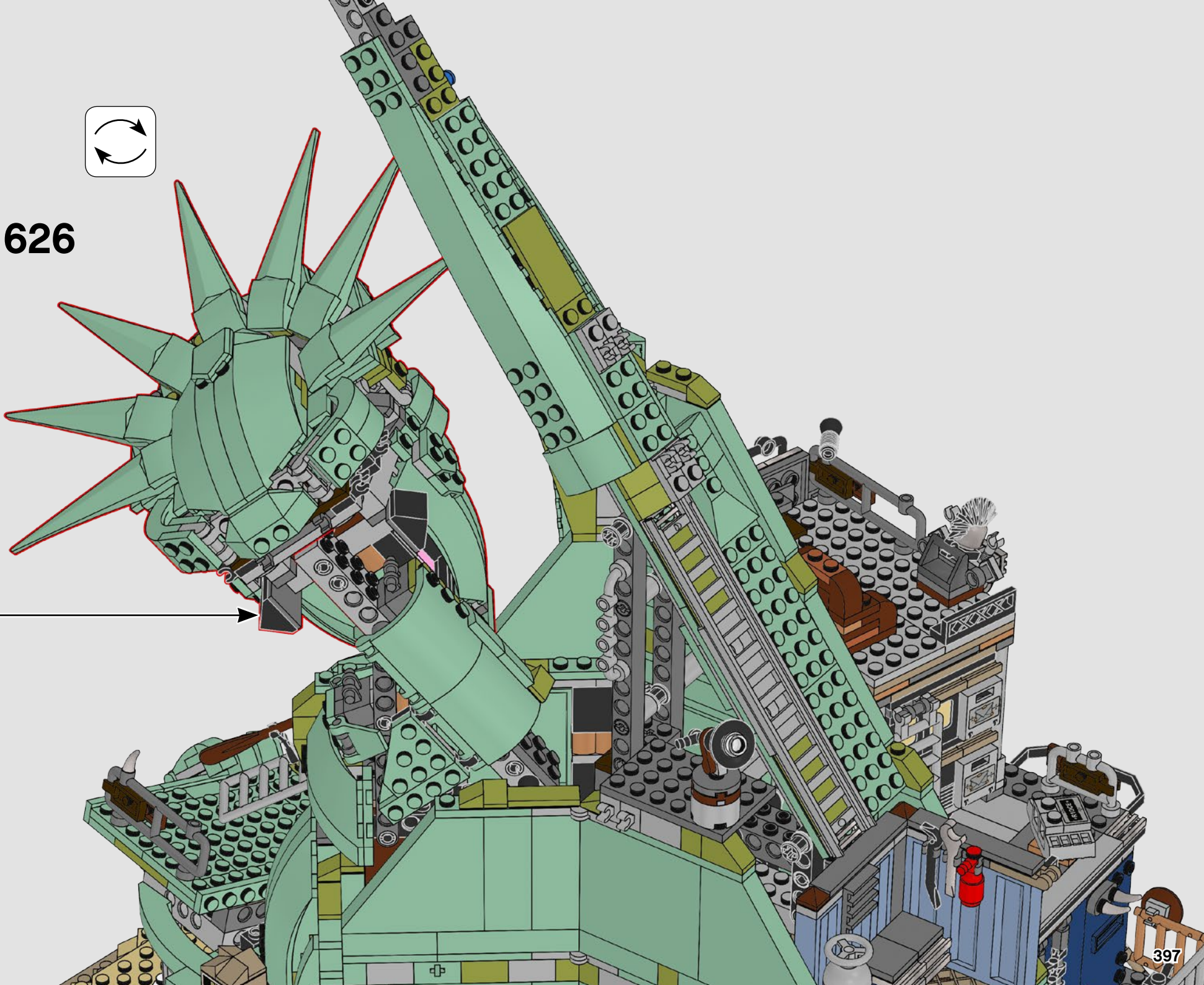



2x



3x

627

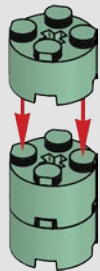

1x

628

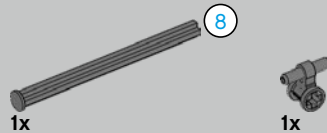
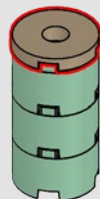

1x

1x

629

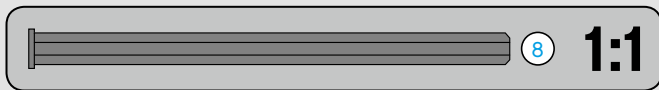

8

1:1

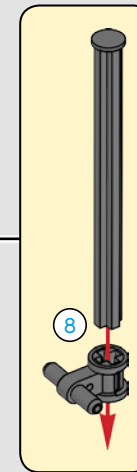
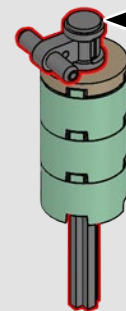

8



3x



1x

630

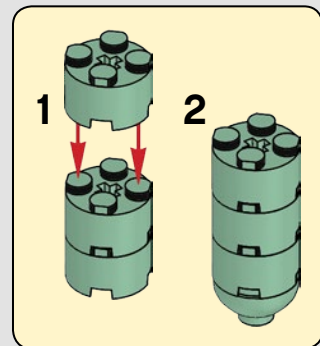

1

2

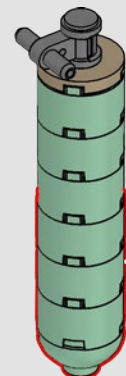

2x

631

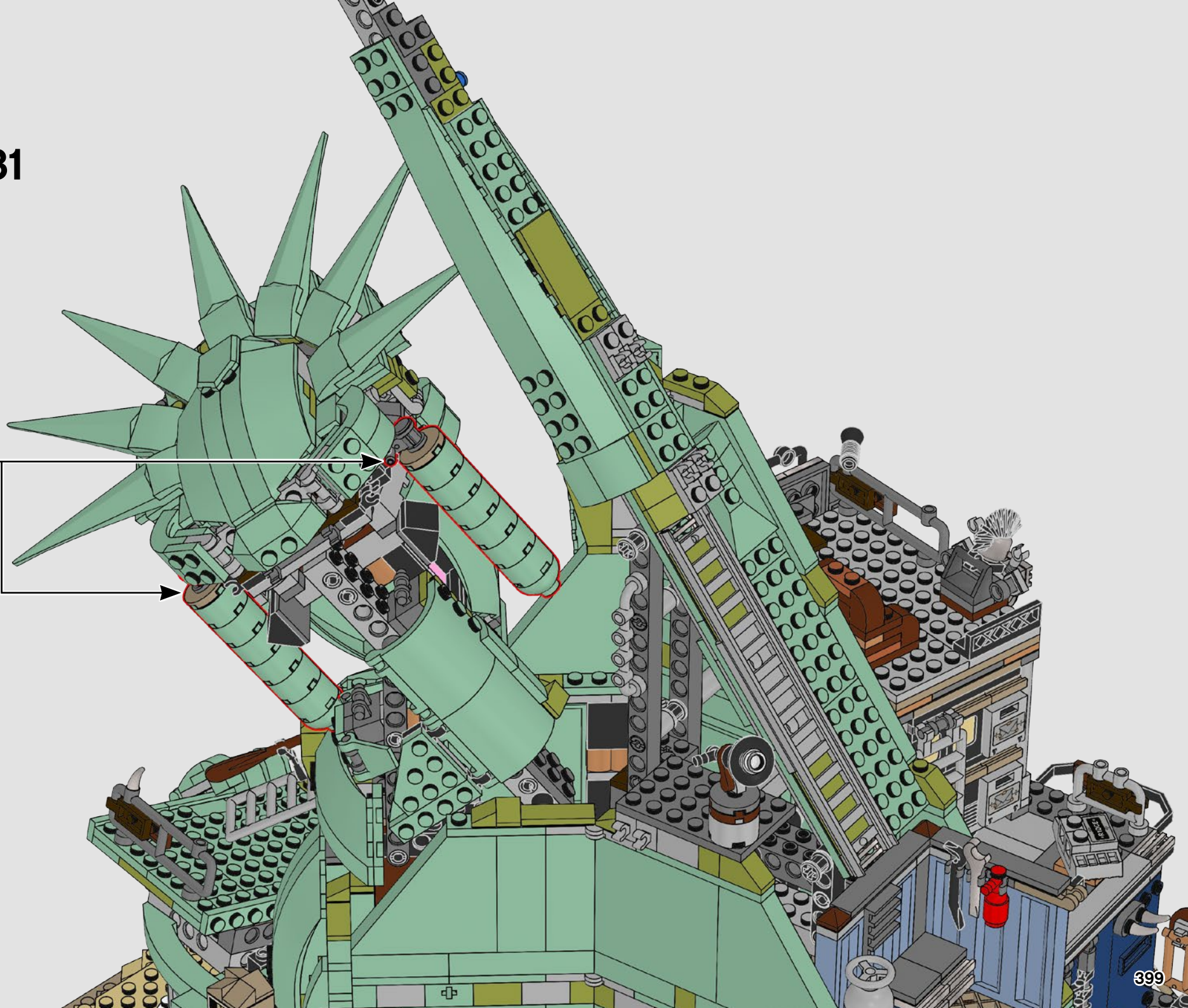



2x



4x

632

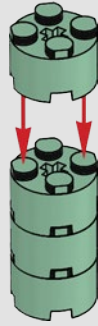

1x

633

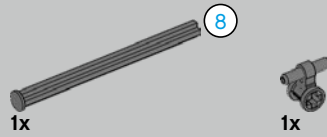

1x

1x

634

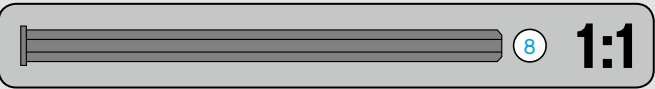
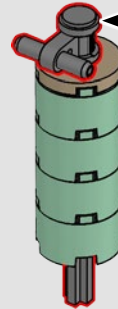

8

1:1

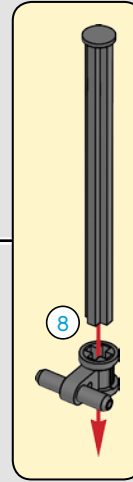

8



3x



1x

635

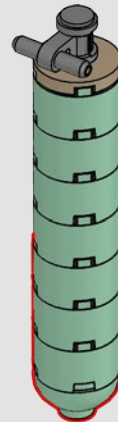

2x

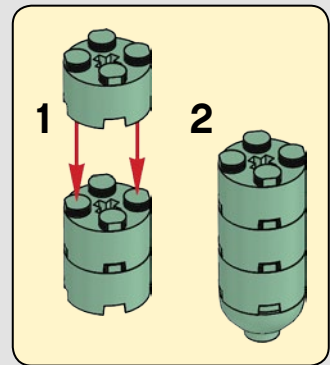

1

2



636

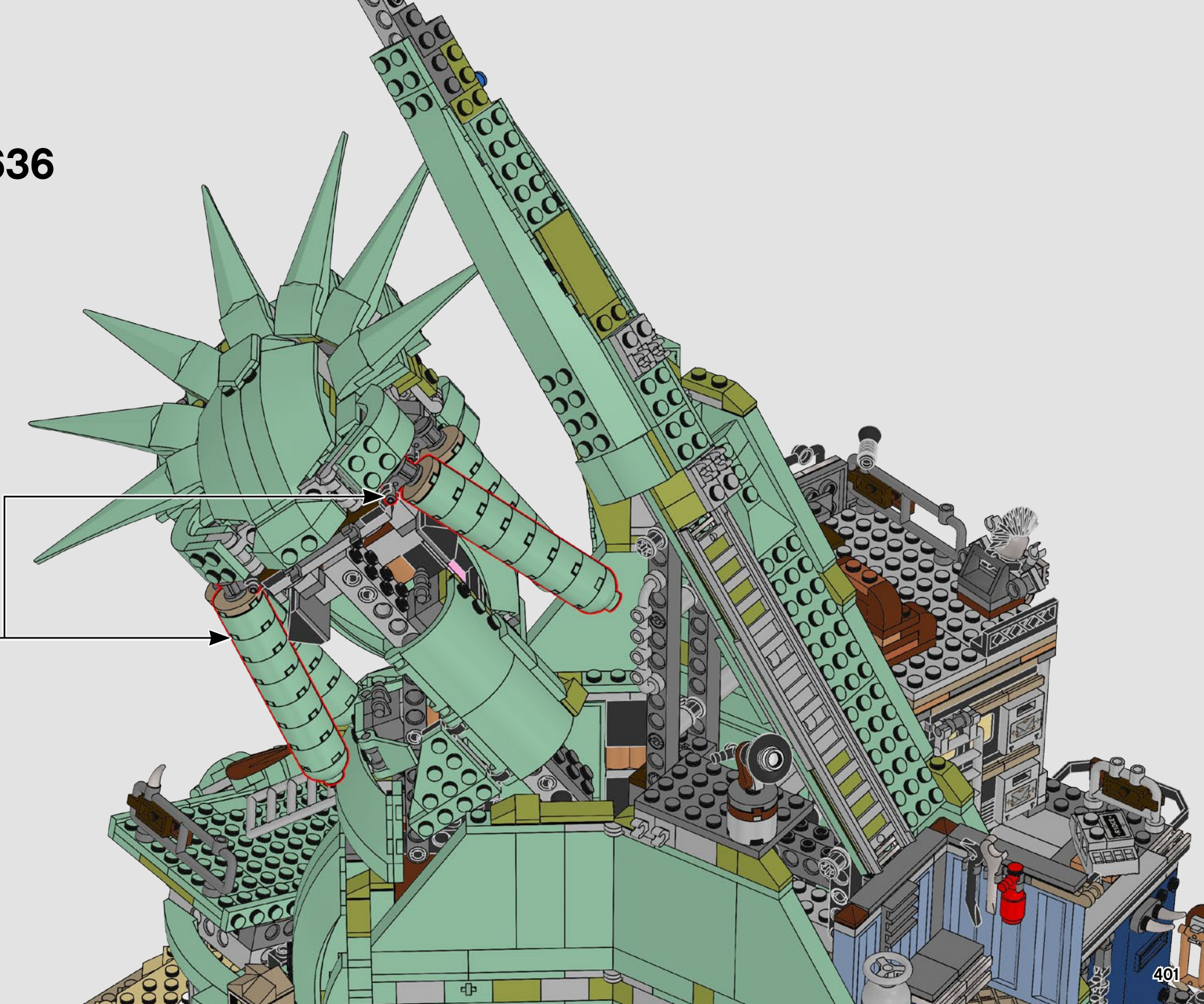

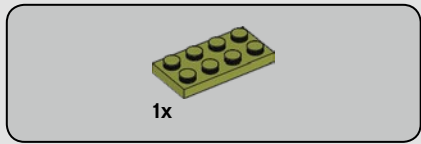

637

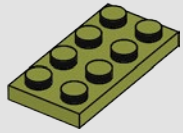

638

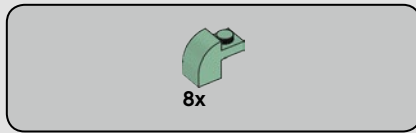
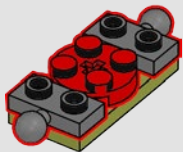

639

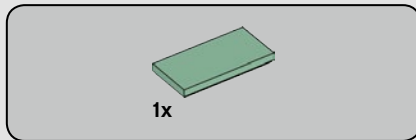
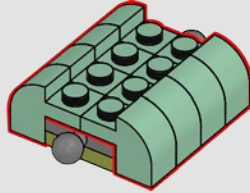

640

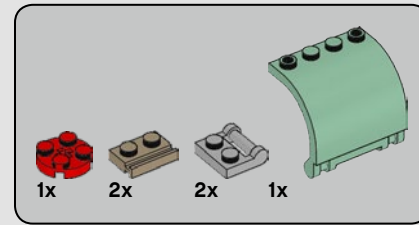
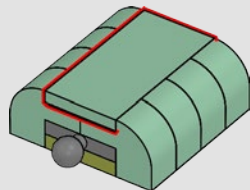

641

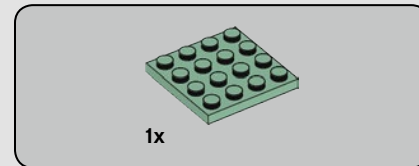
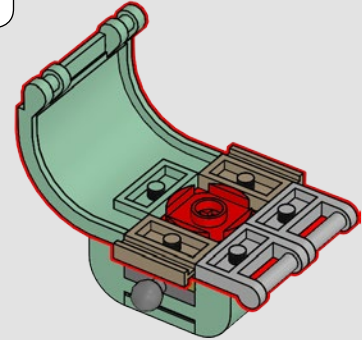
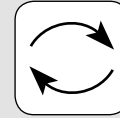

642

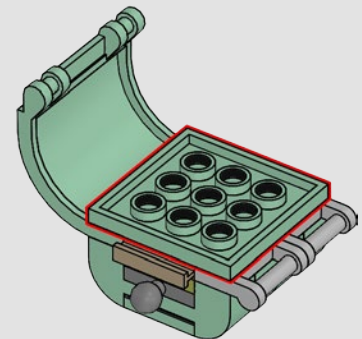

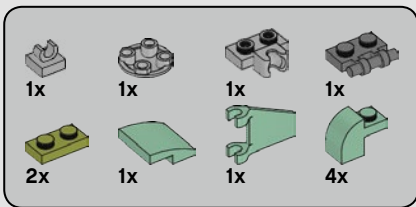

# 643

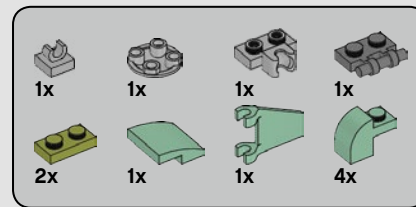
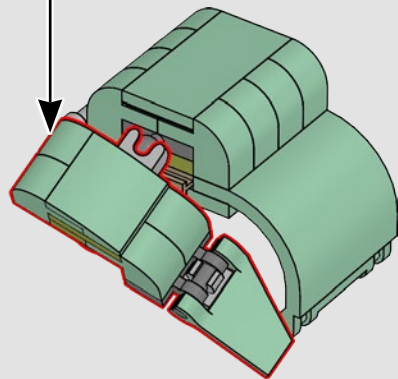
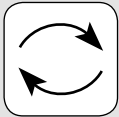
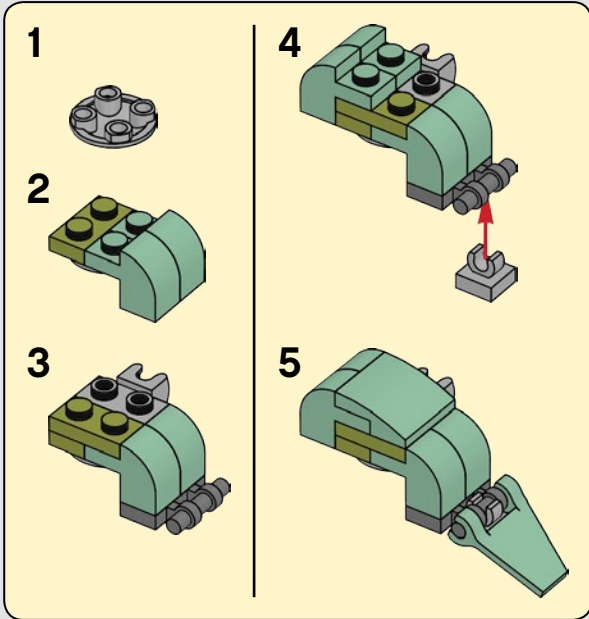

# 644

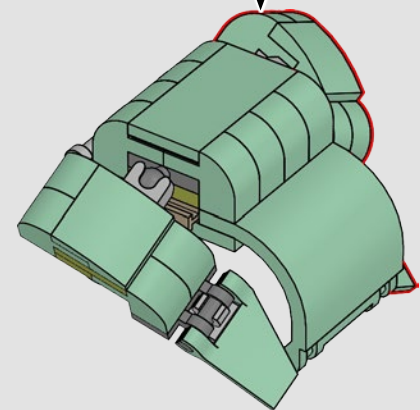
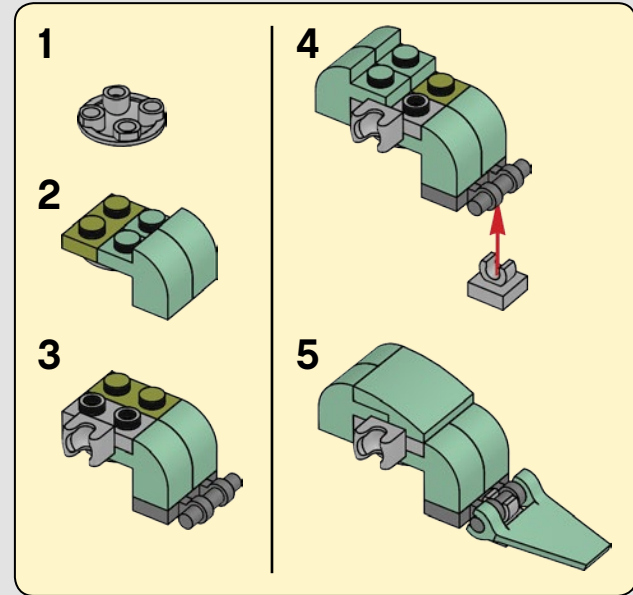

645

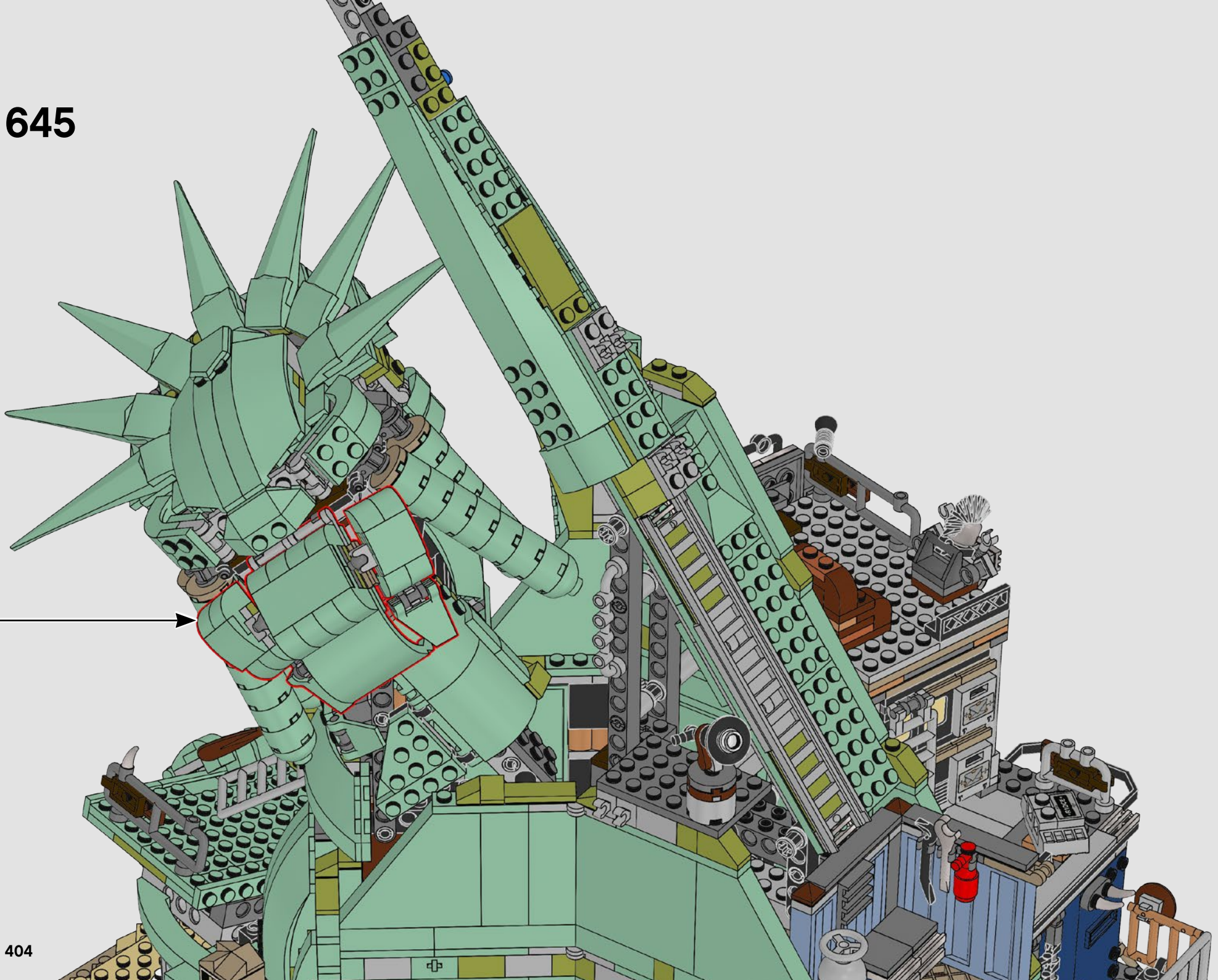

404

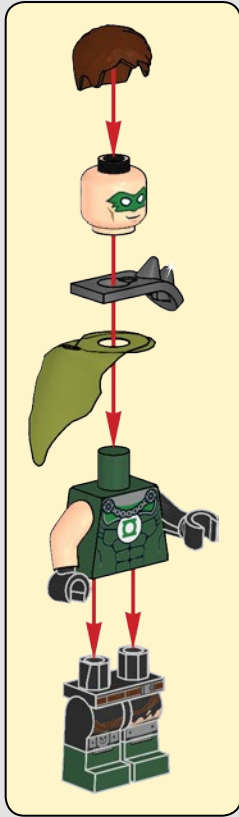
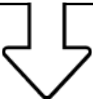

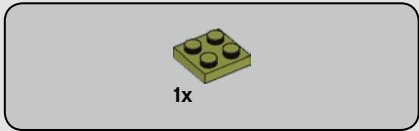
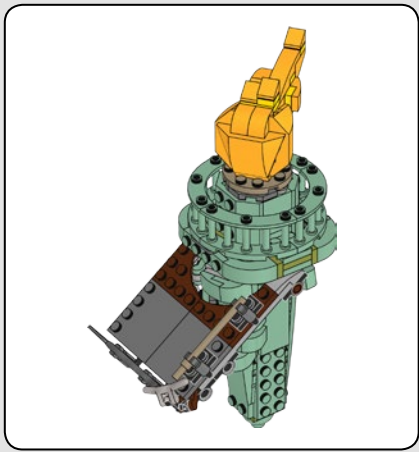

646

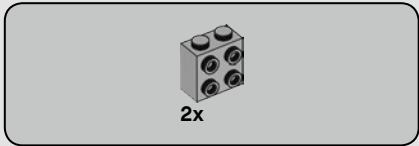
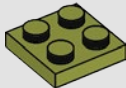

647

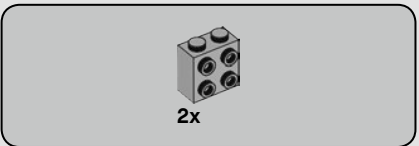
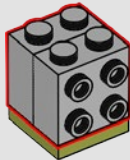

648

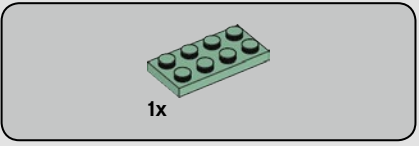
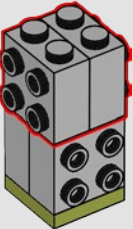

649

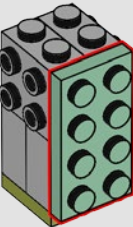

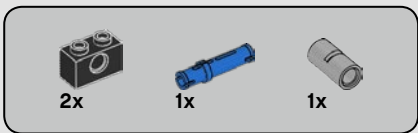

650

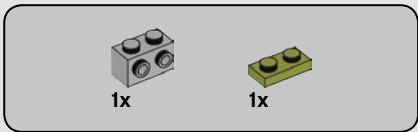
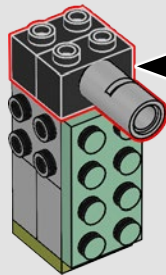
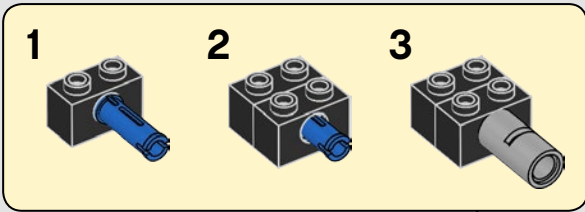

651

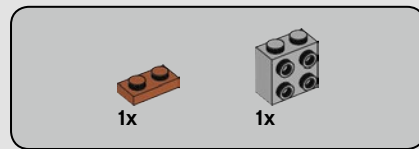
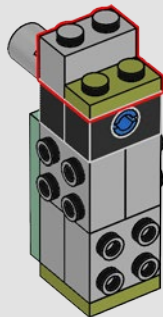
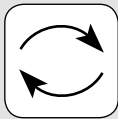

652

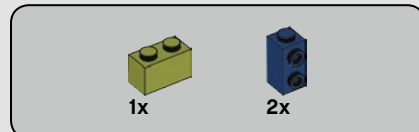
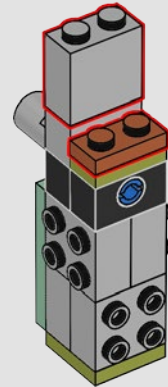

653

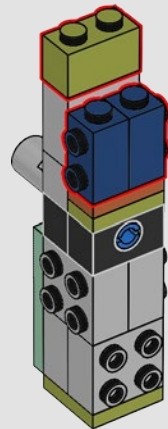

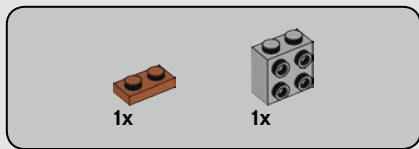

654

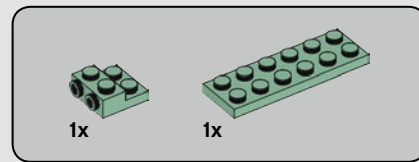
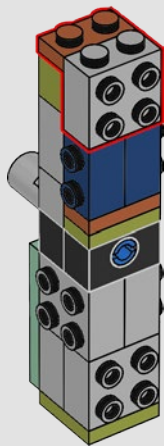

655

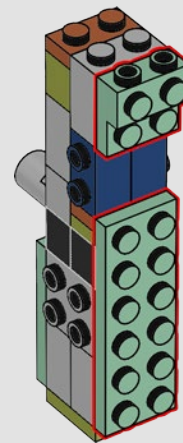



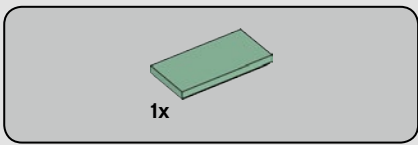

656

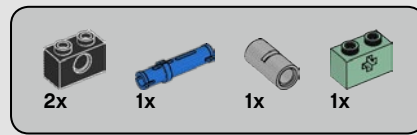
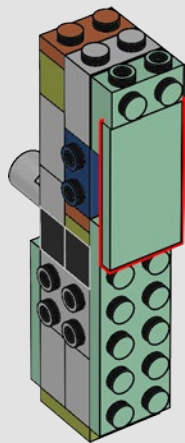

657

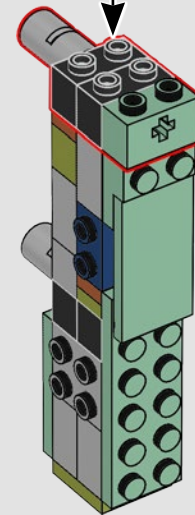
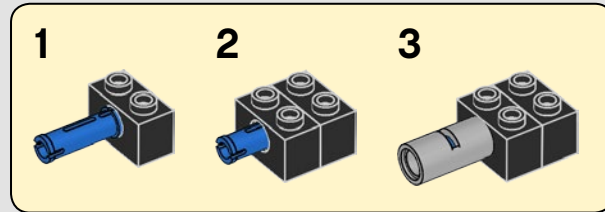

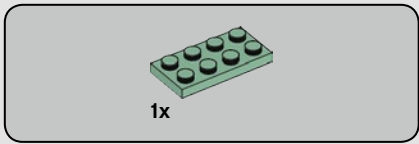

658

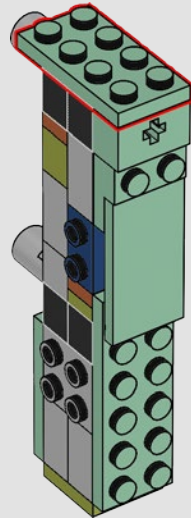

659

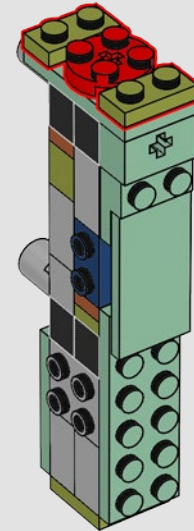

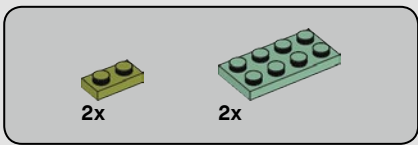

660

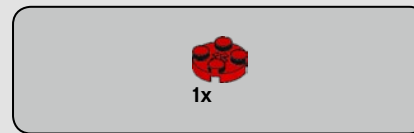
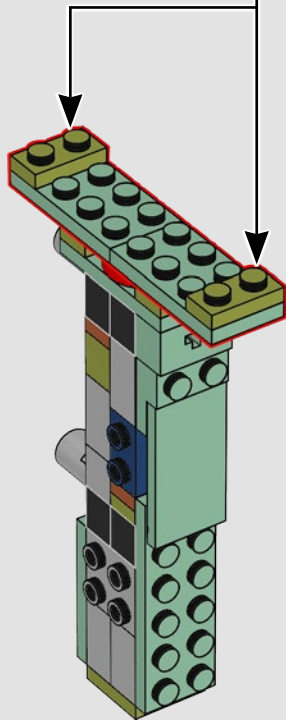
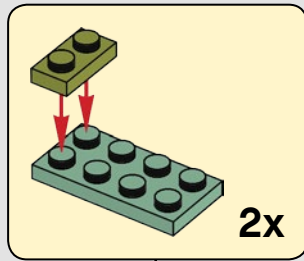

661

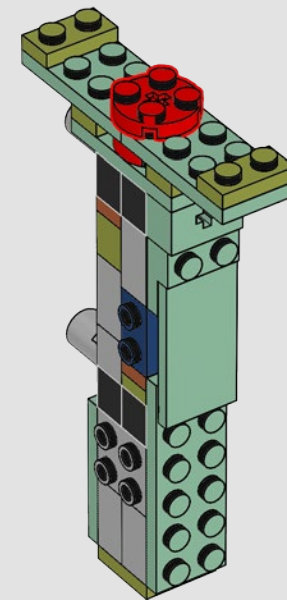

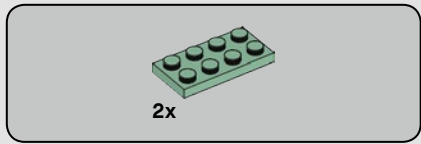

662

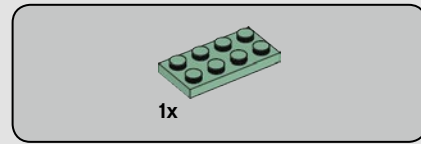
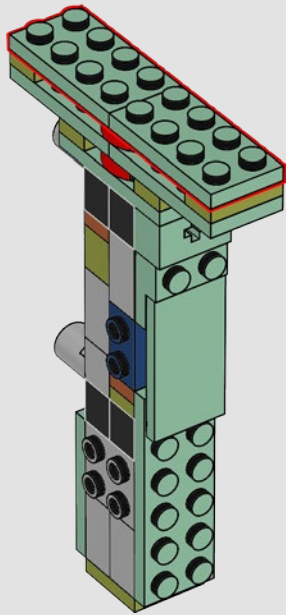

663

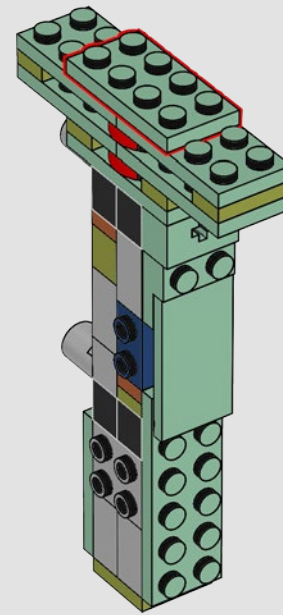



664

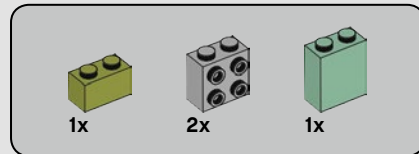
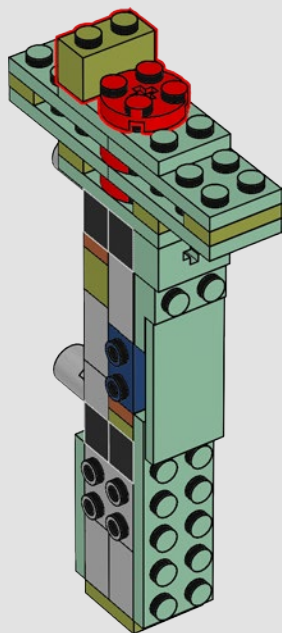

665

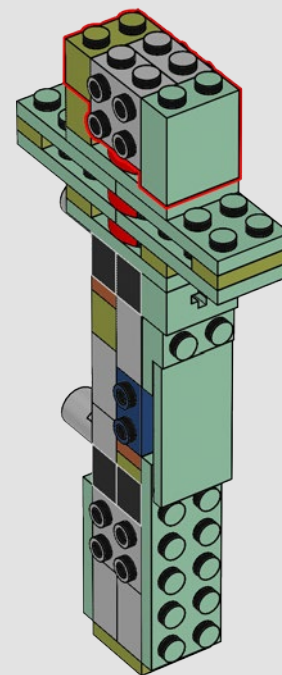

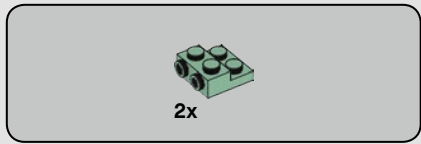

666

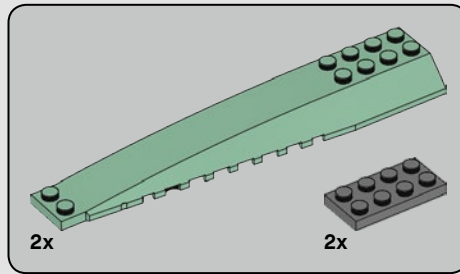
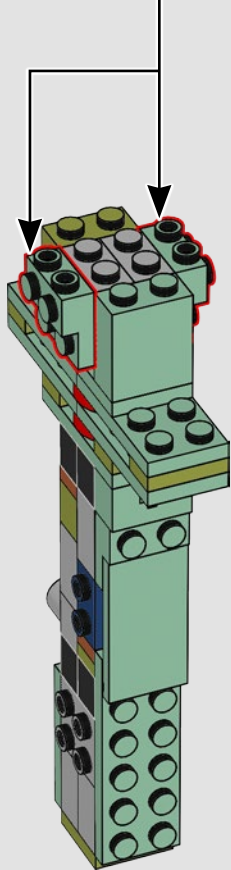
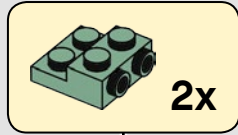

667

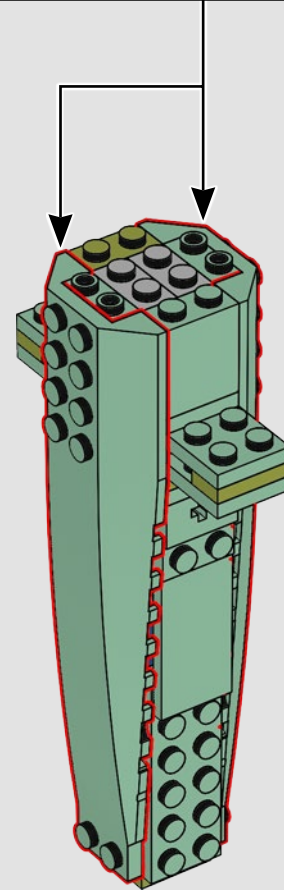
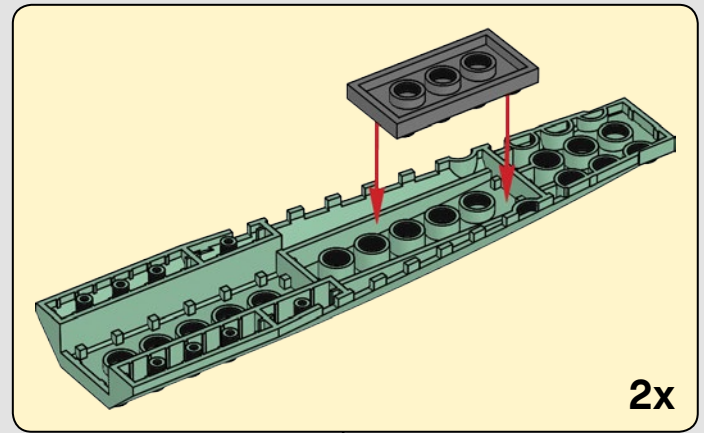

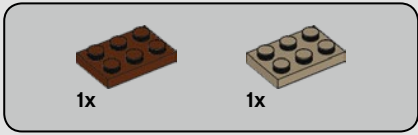
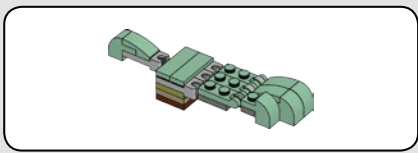

668

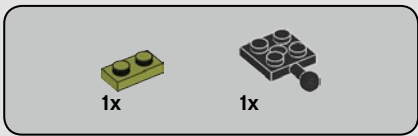
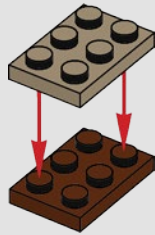

669

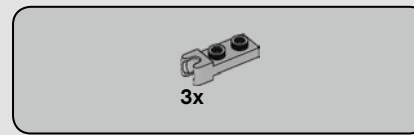

670

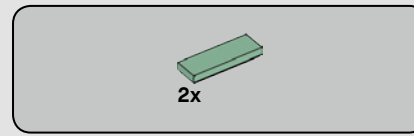

671

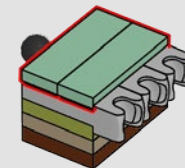

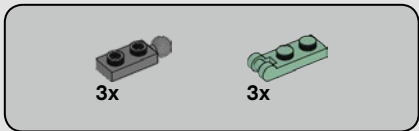

672

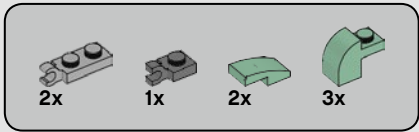
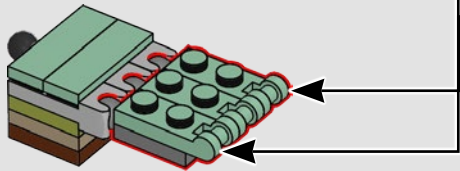
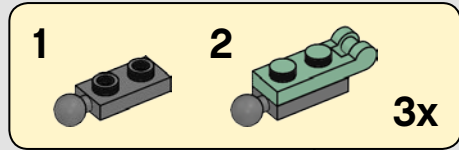

673

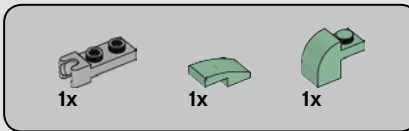
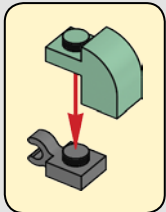
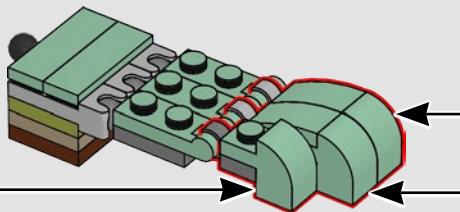
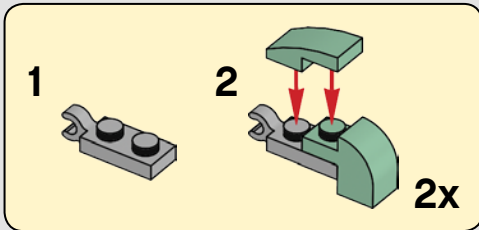

674

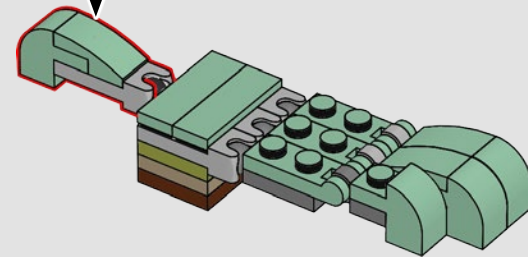
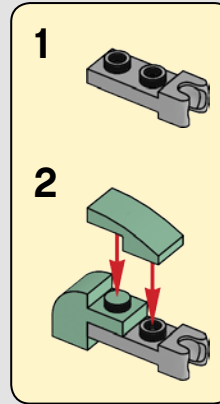



# 675

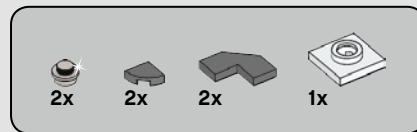
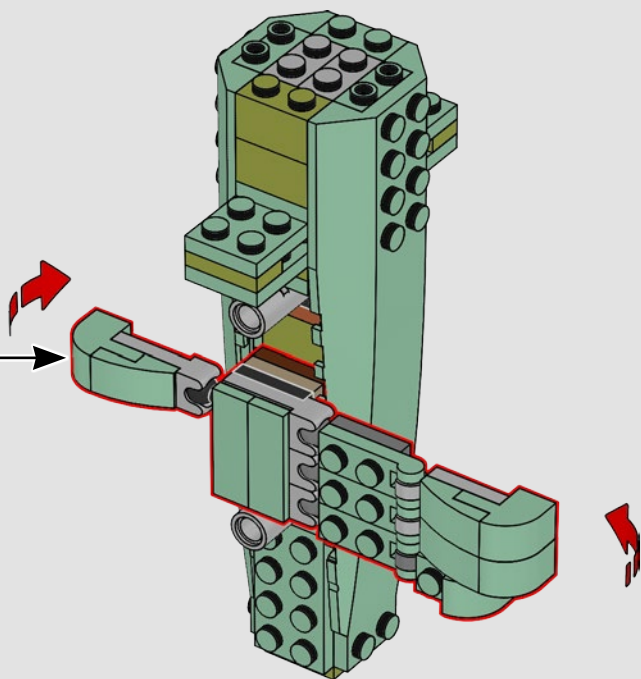
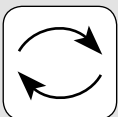

# 676

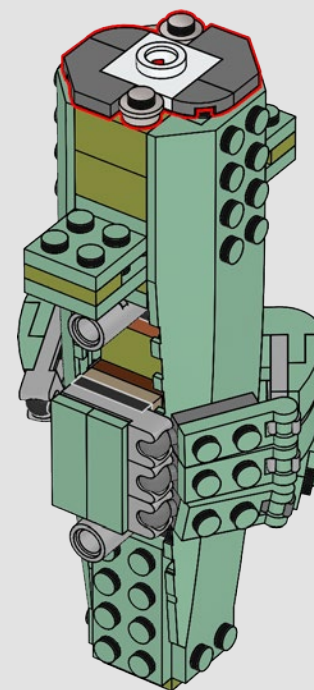

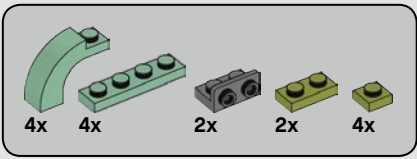

677

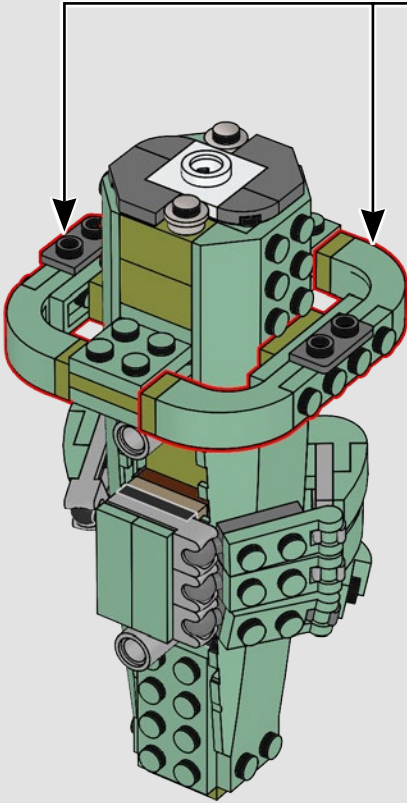
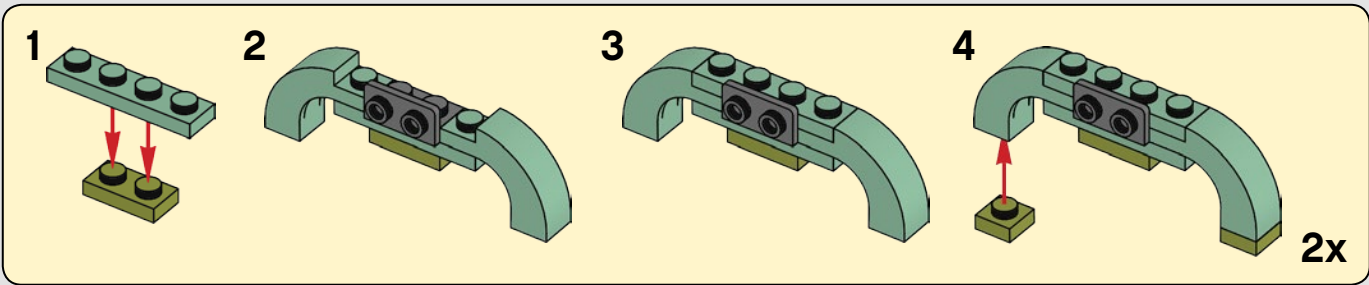

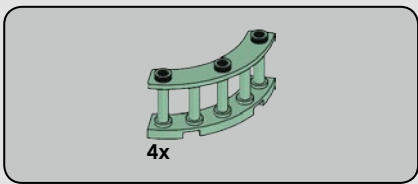

678

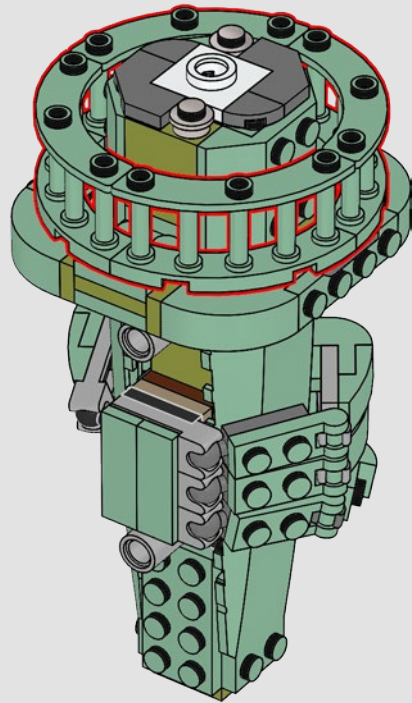

679

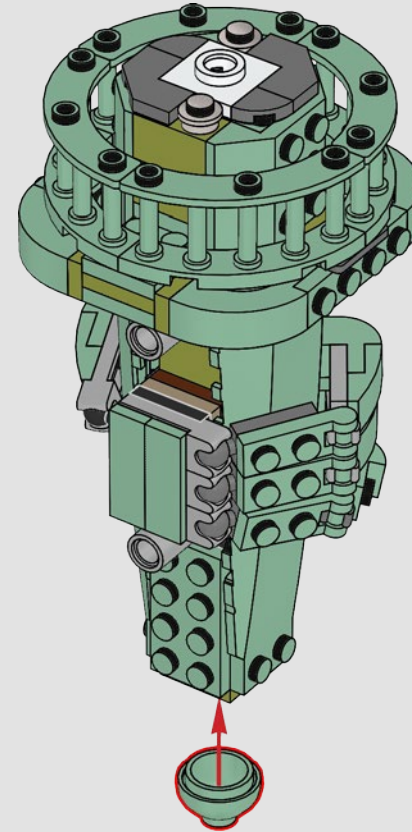



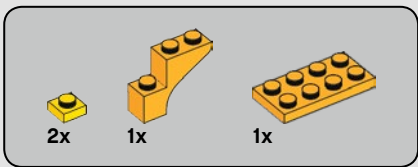

684

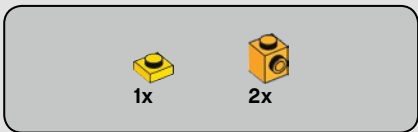
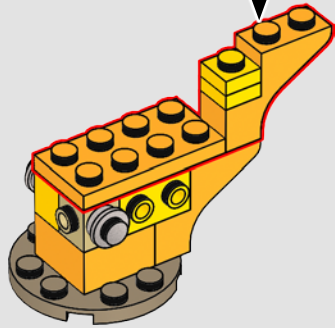
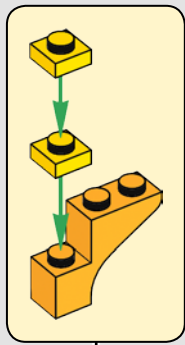

685

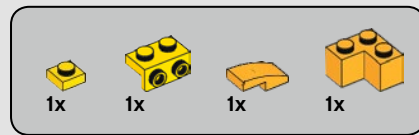
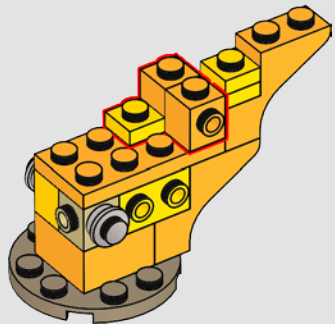

686

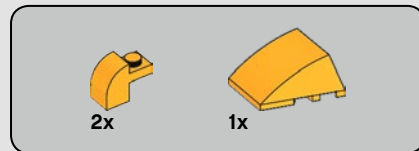
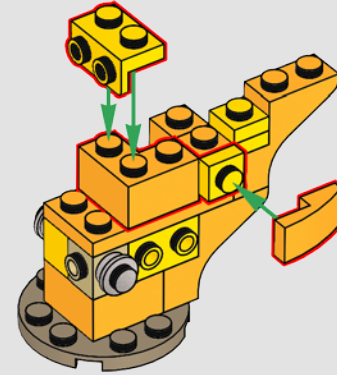

687

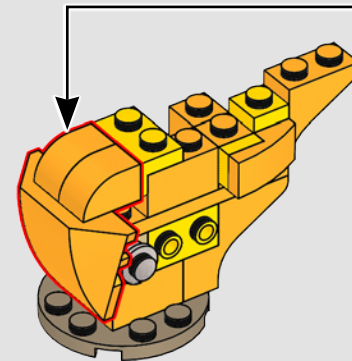
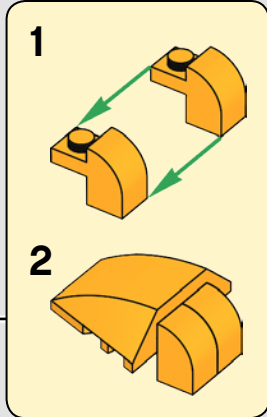

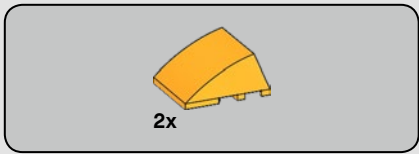

688

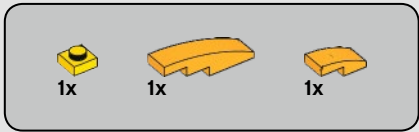
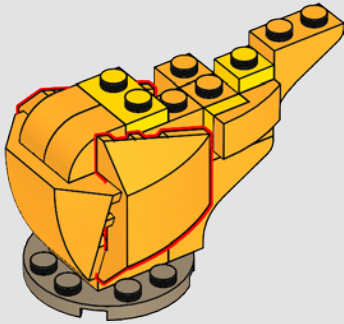

689

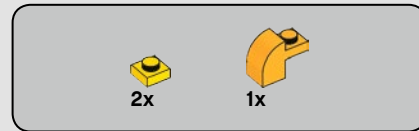
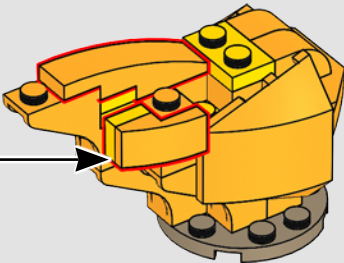
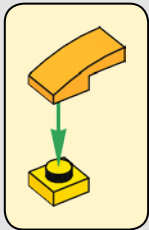
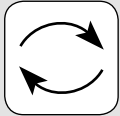

690

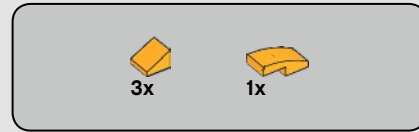
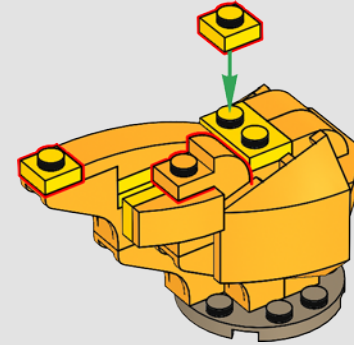

691

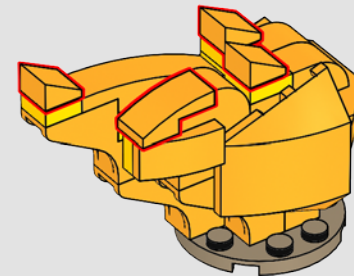

692

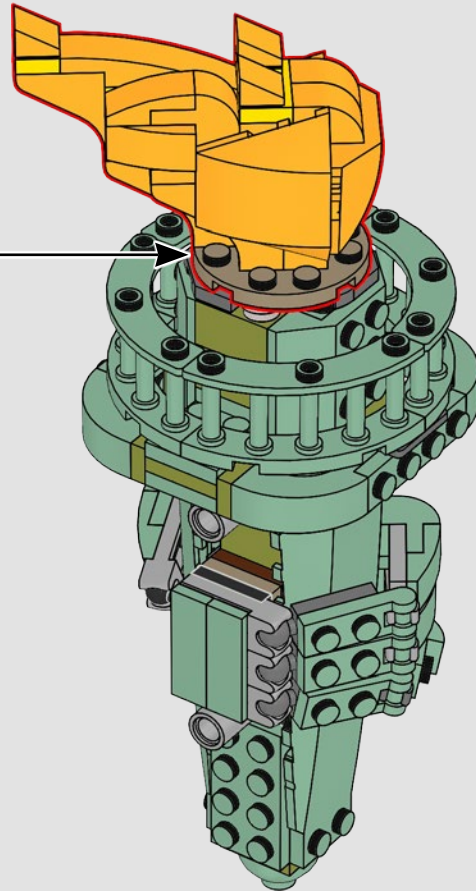

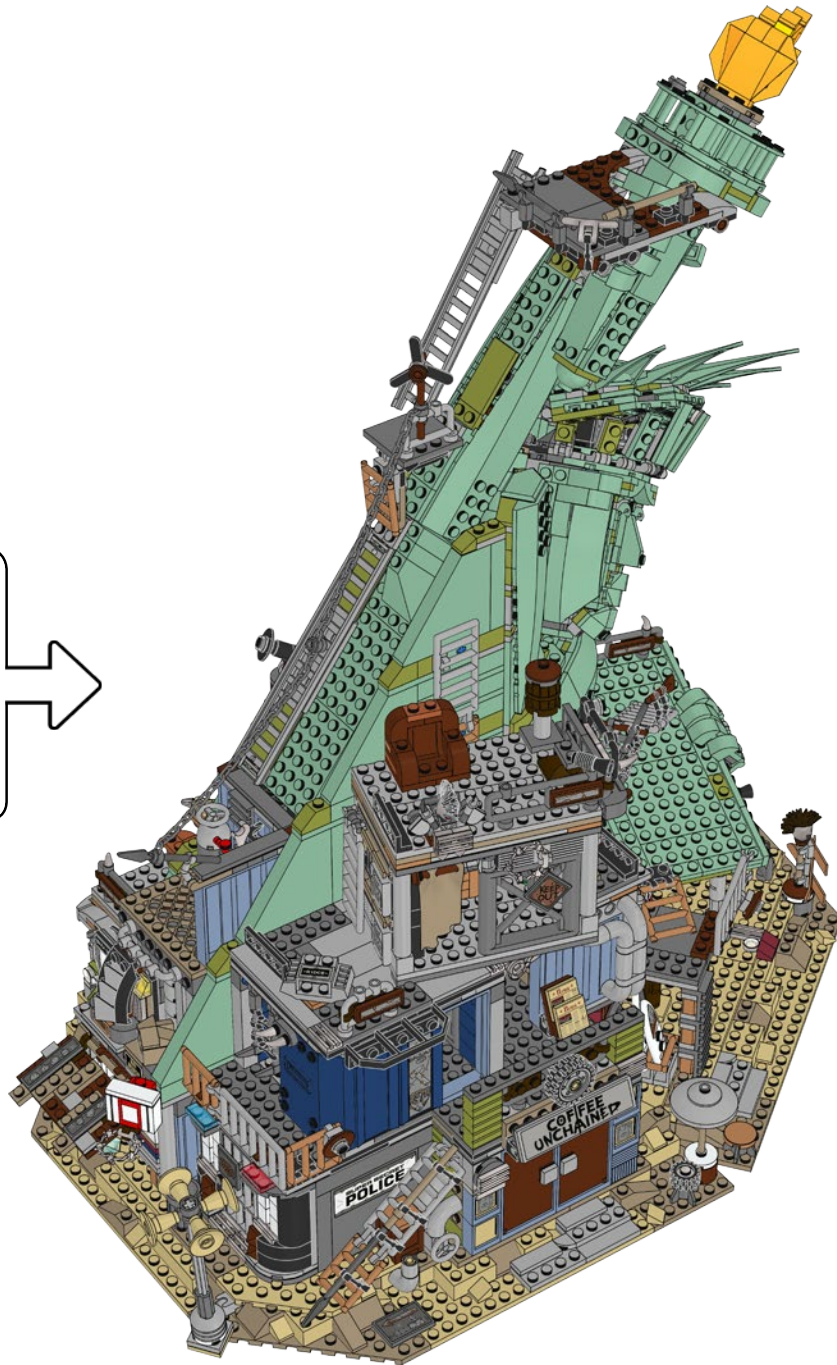



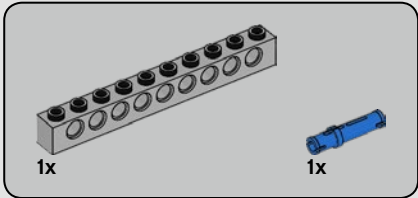
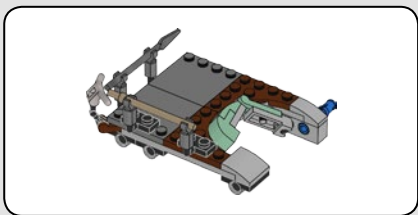

693

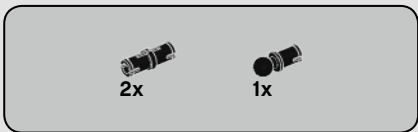
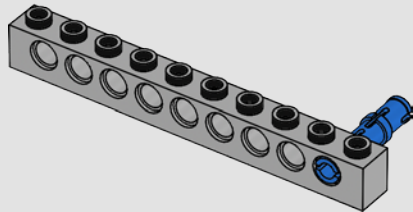

694

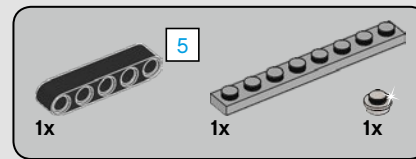
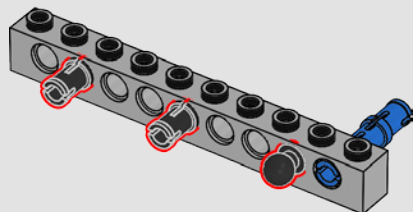

695

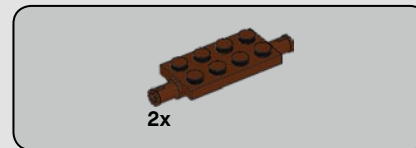
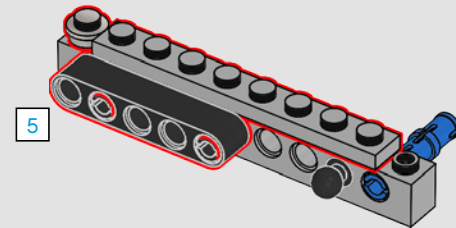

696

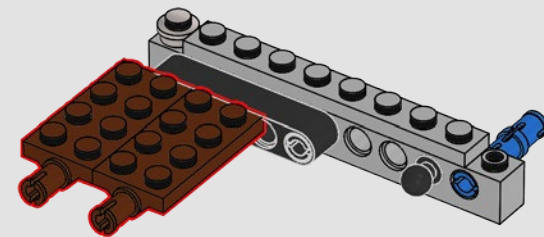

1:1



2x

# 697

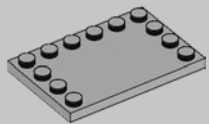
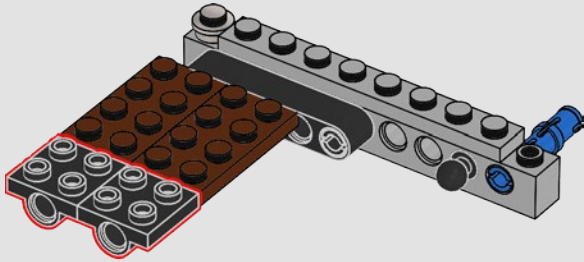

1x

# 698

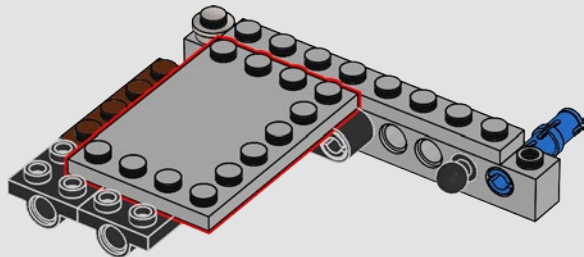

1x

2x

1x

1x

# 699

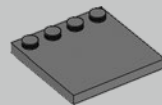
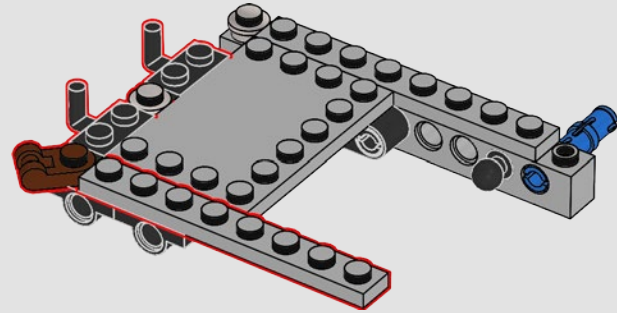

2x

2x

# 700

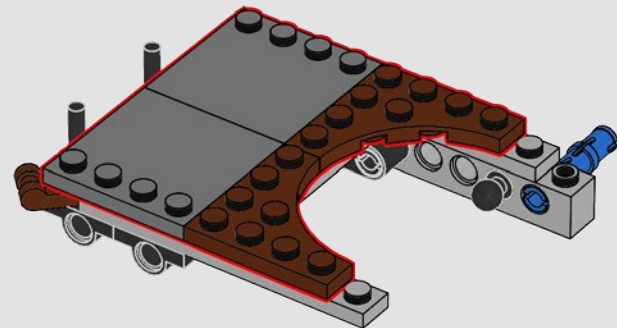

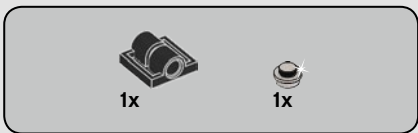

701

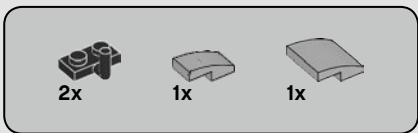
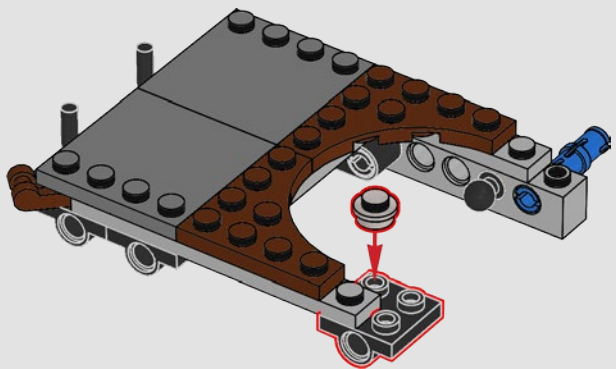

702

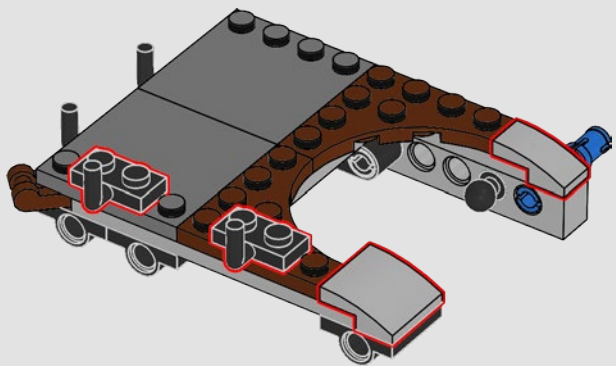

703

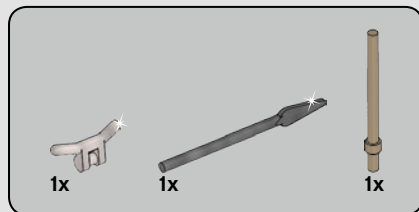
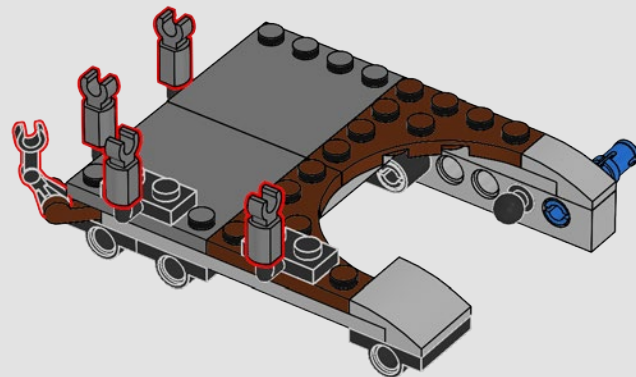

704

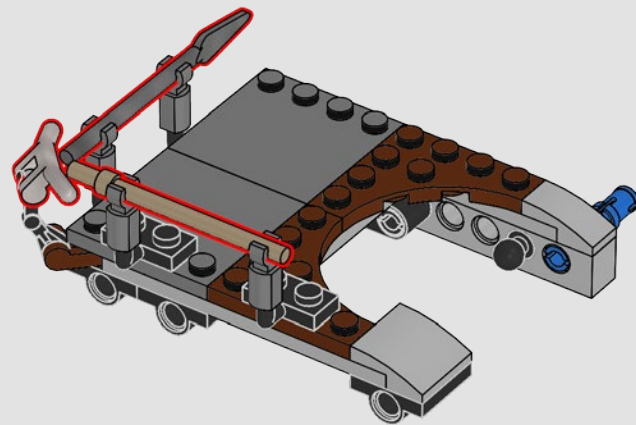

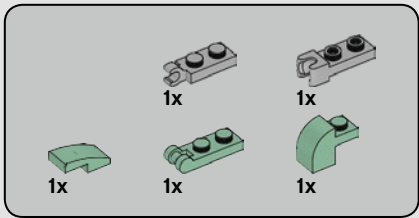

705

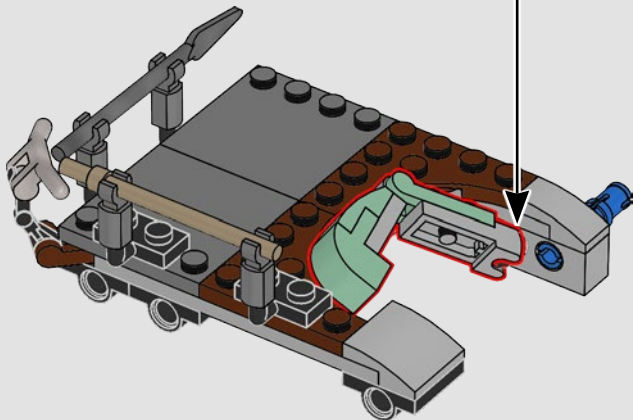
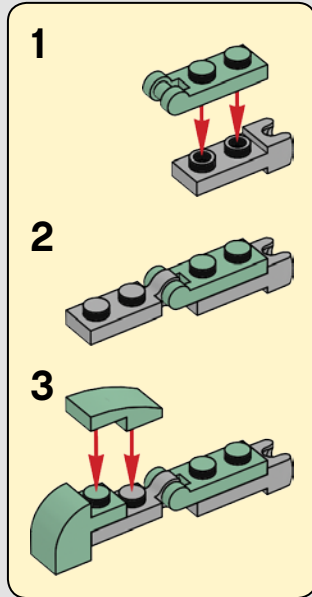

706

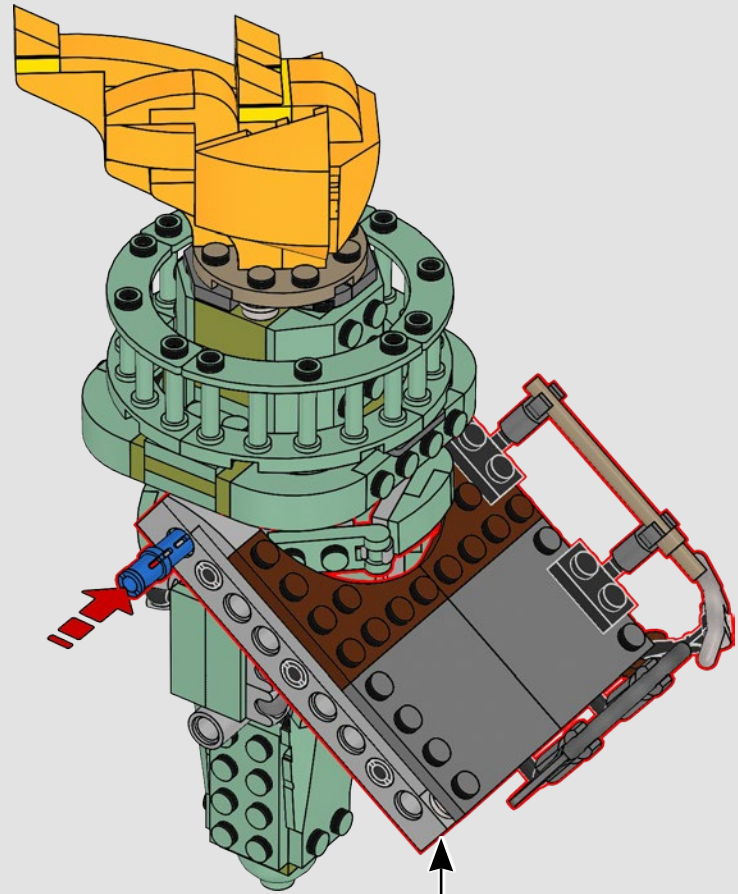

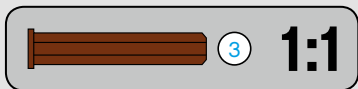
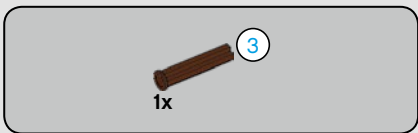

707

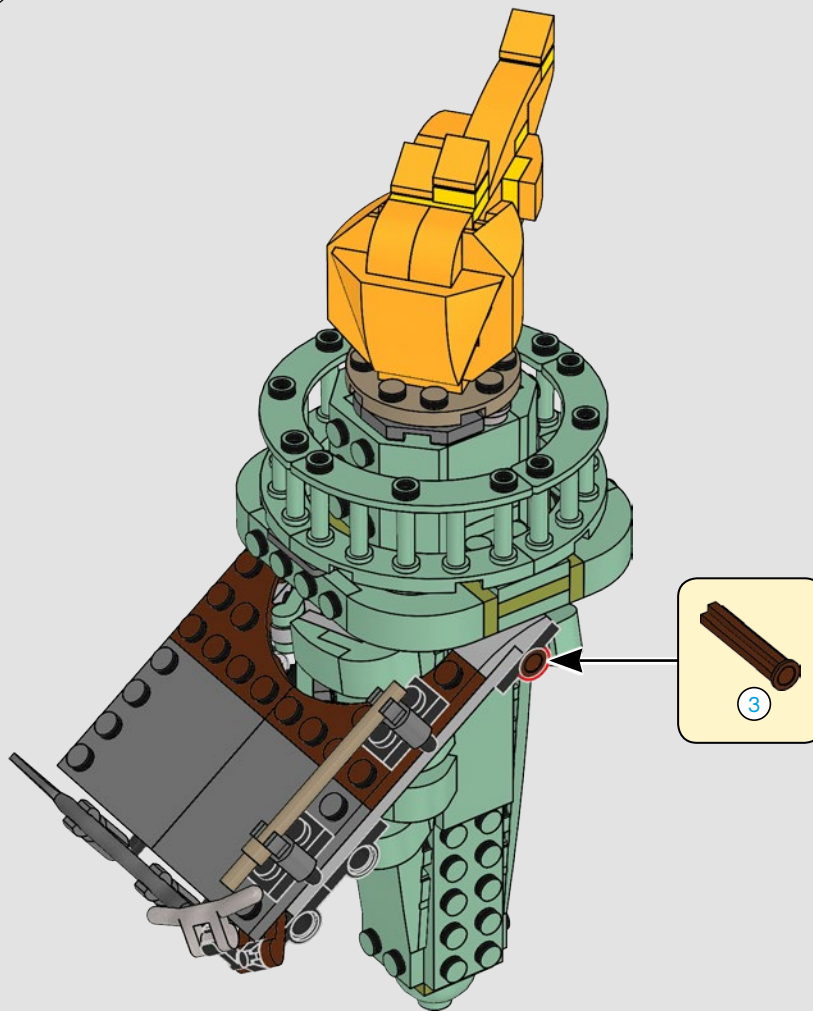
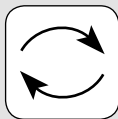

708

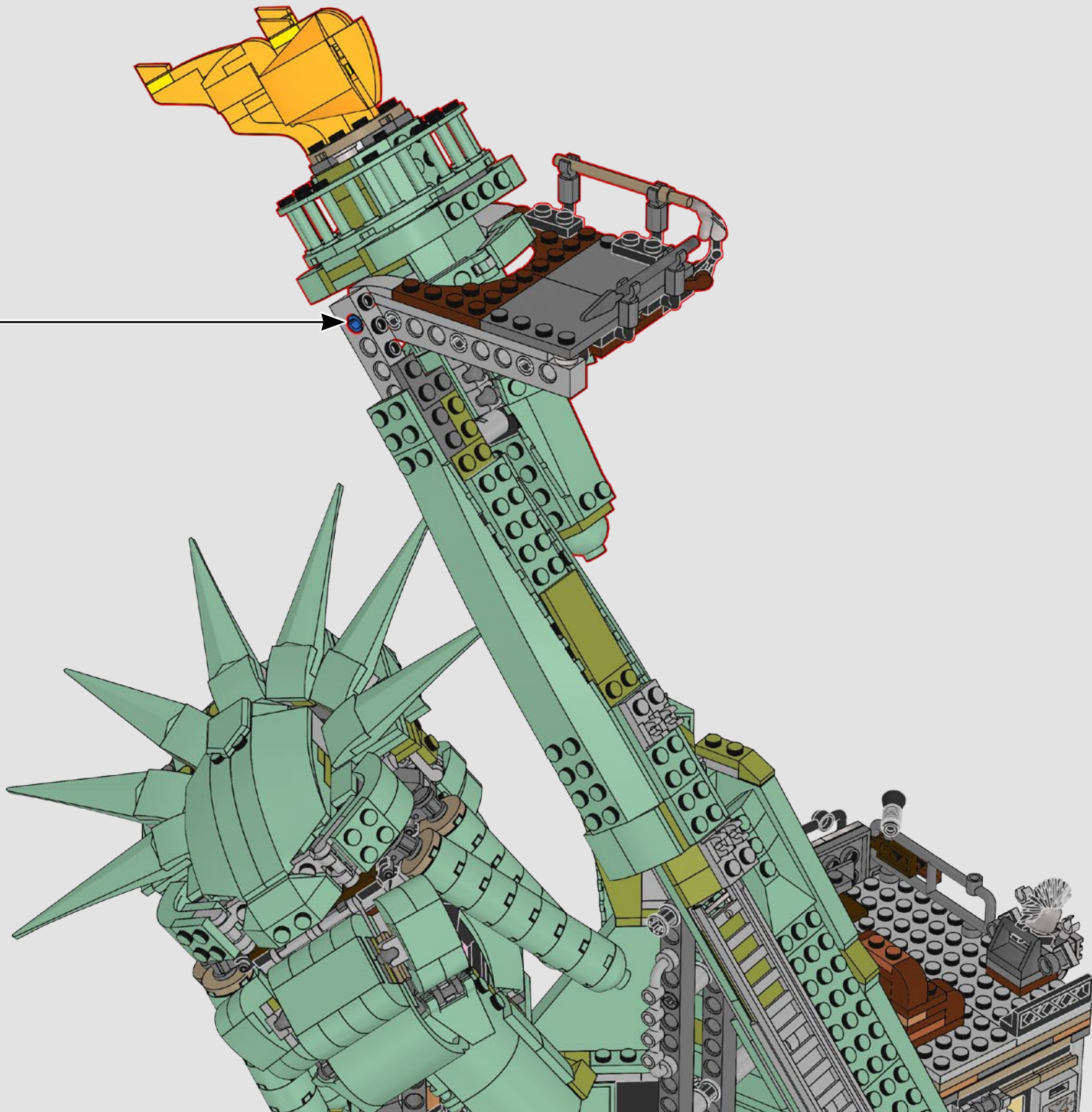

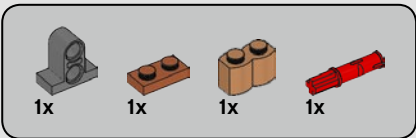

709

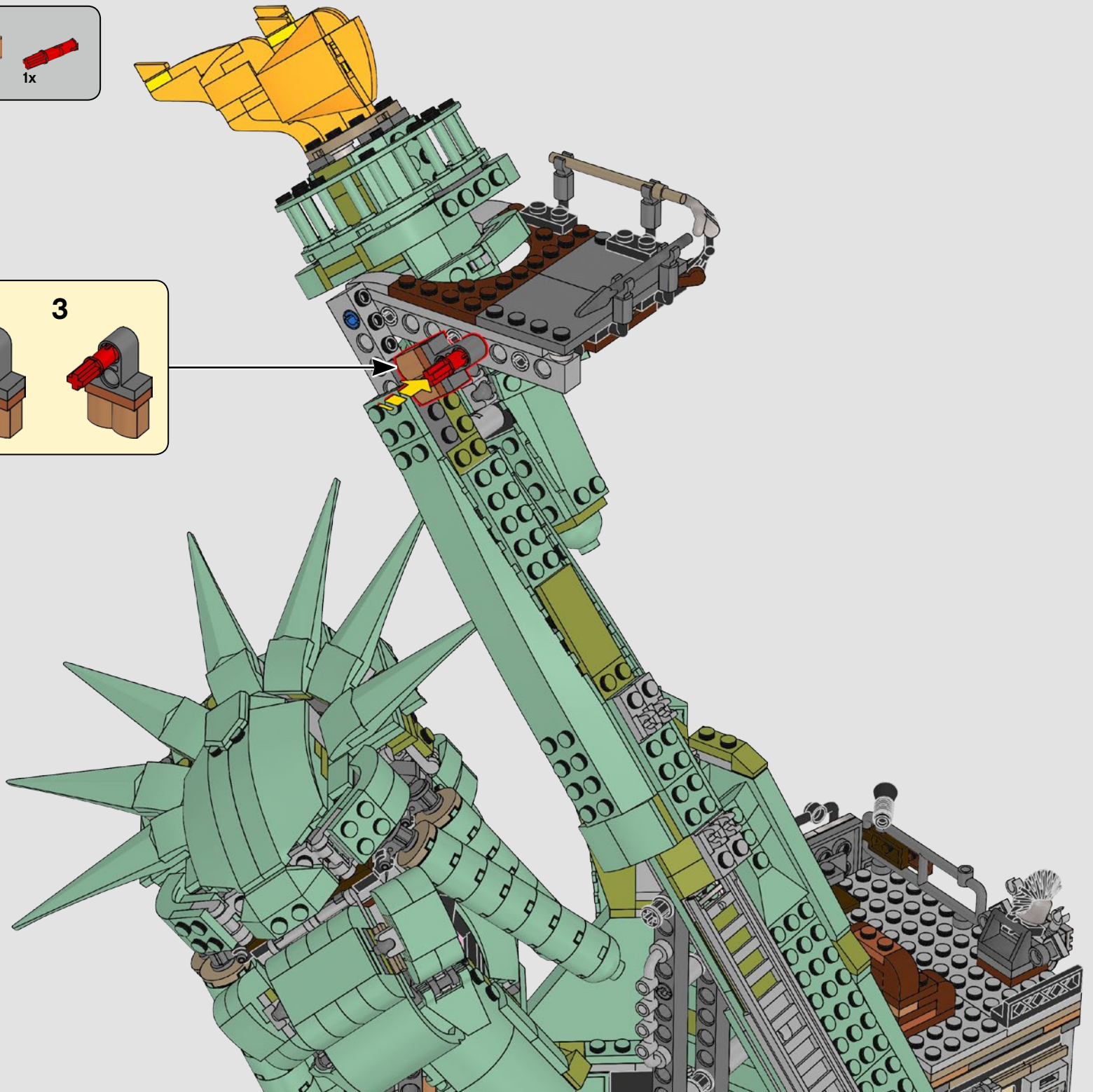
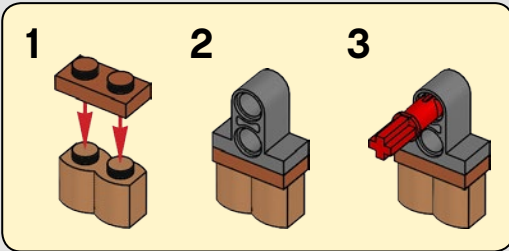

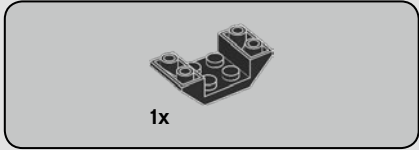
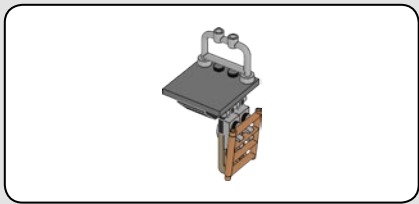

710

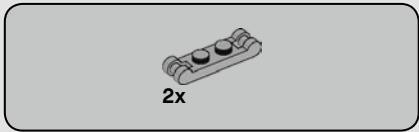
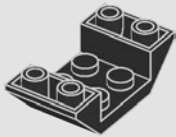

711

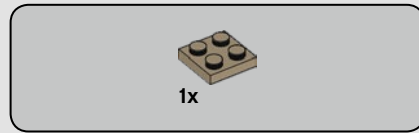
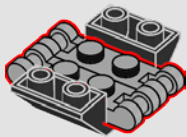

712

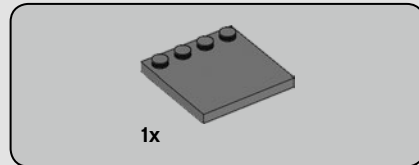
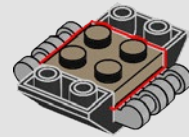

713

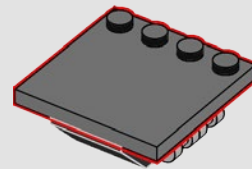



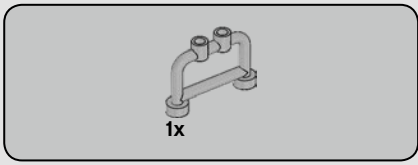

714

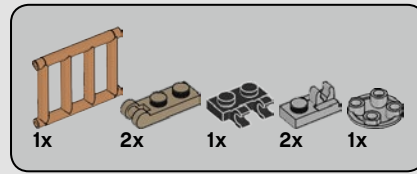
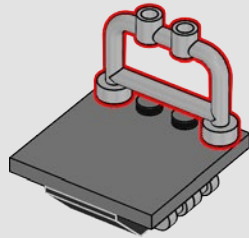

715

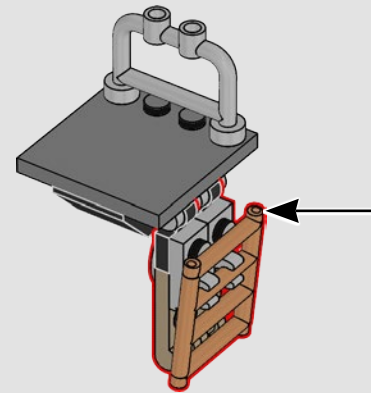
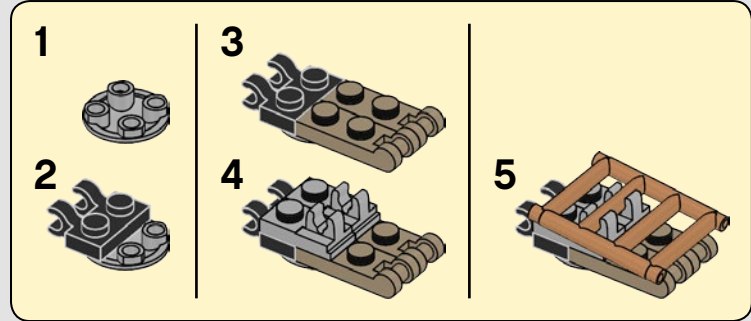

716

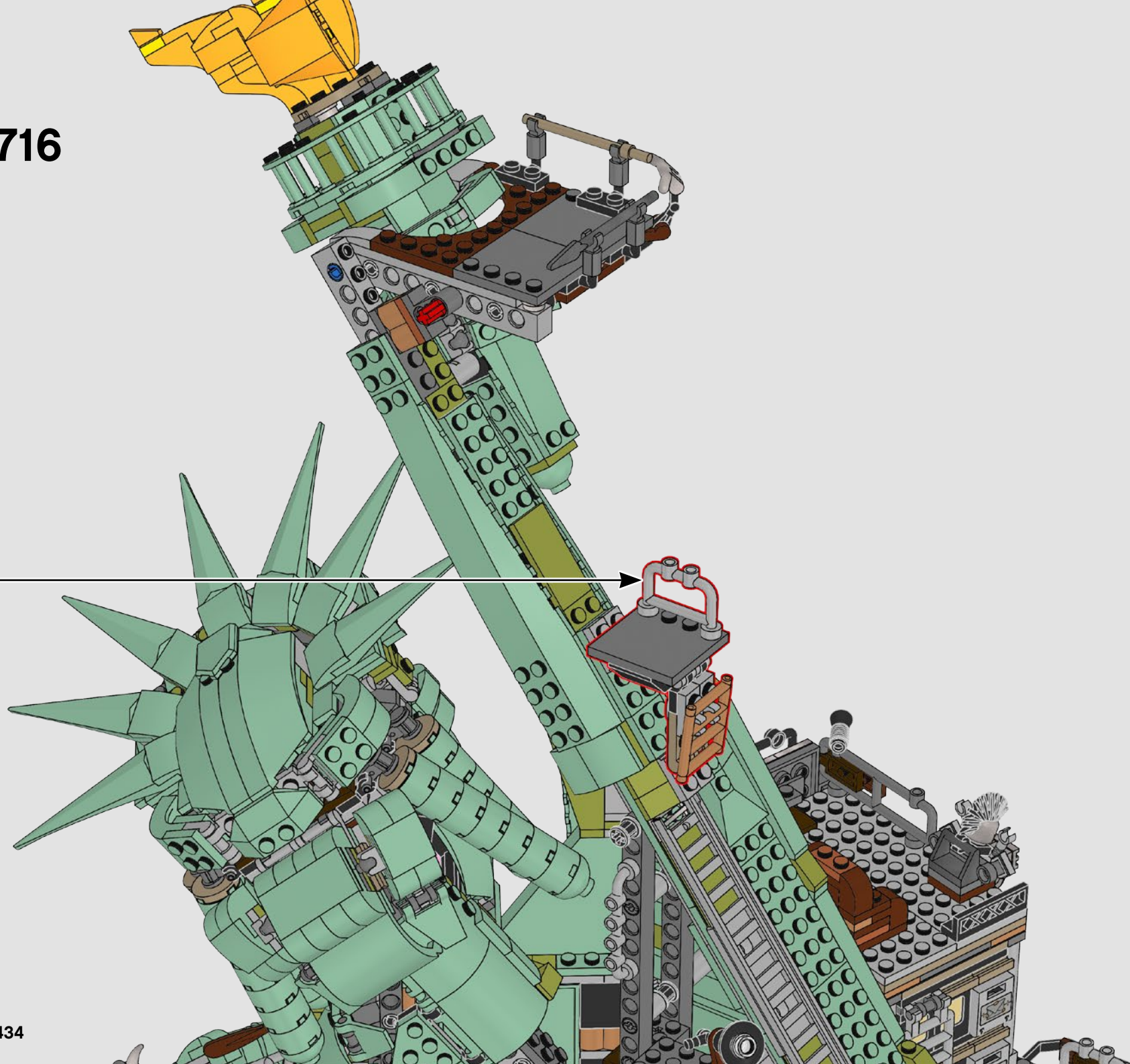

434



717

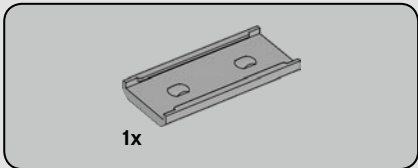
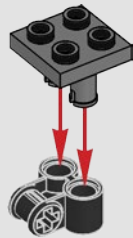

718

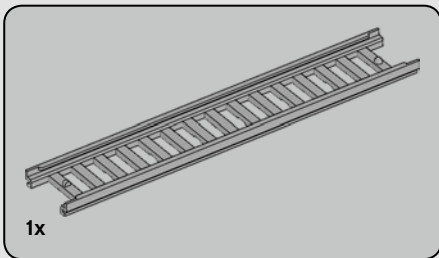
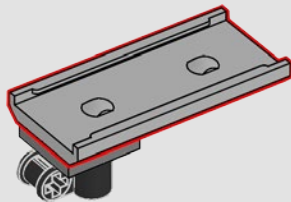

719

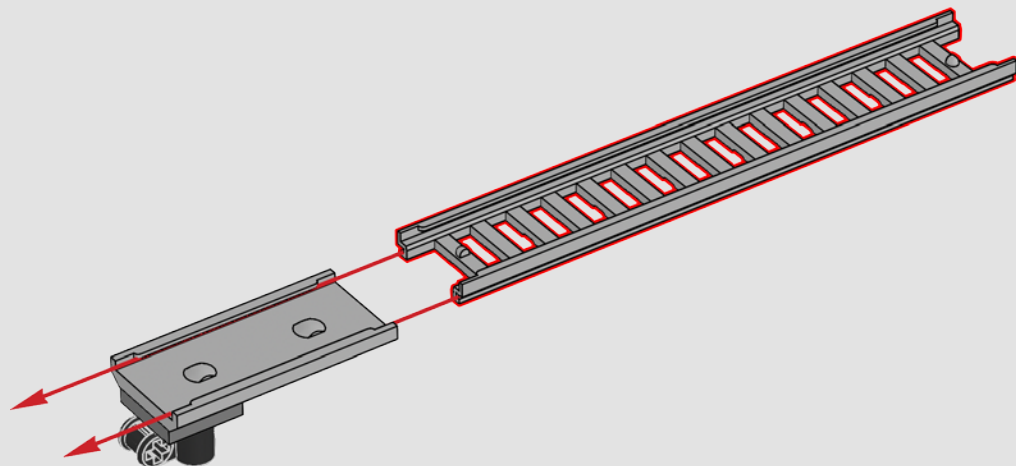

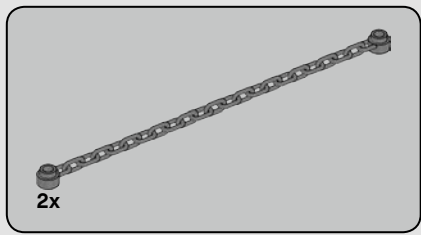

720

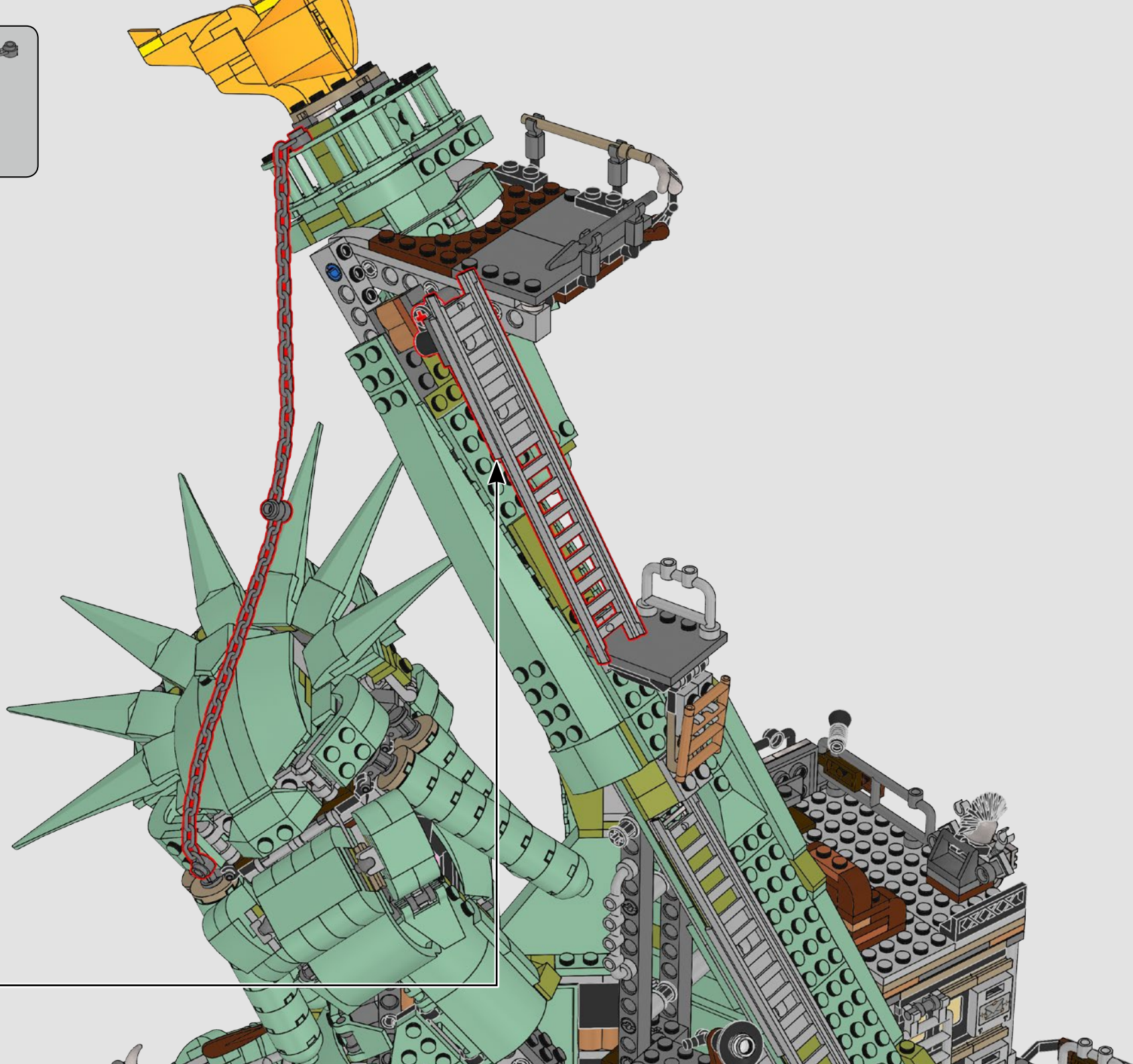

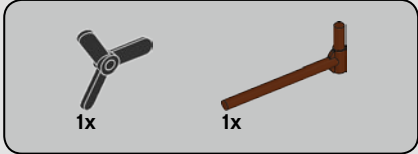
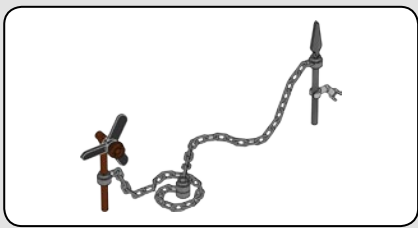

721

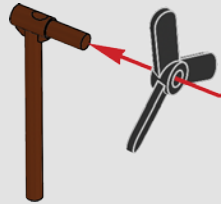

722

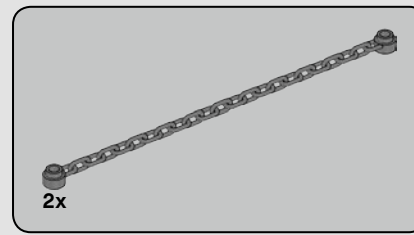
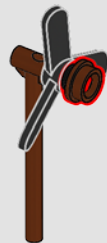

723

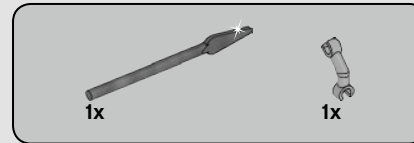
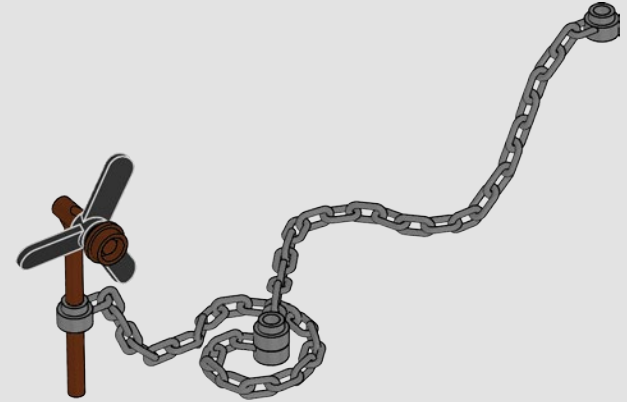

724

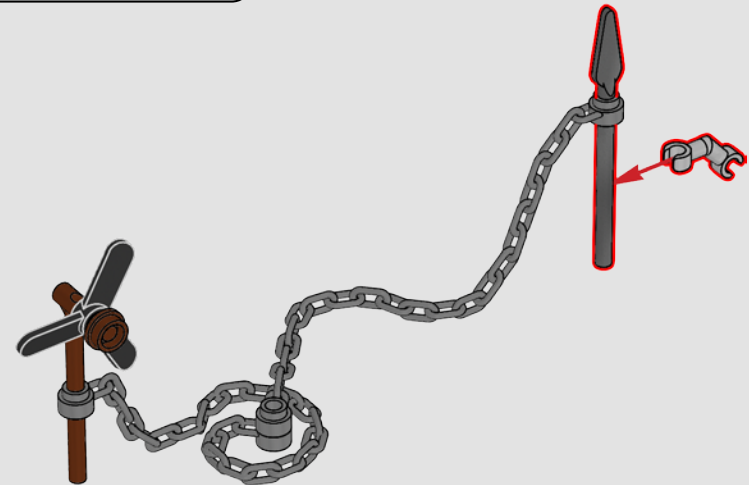

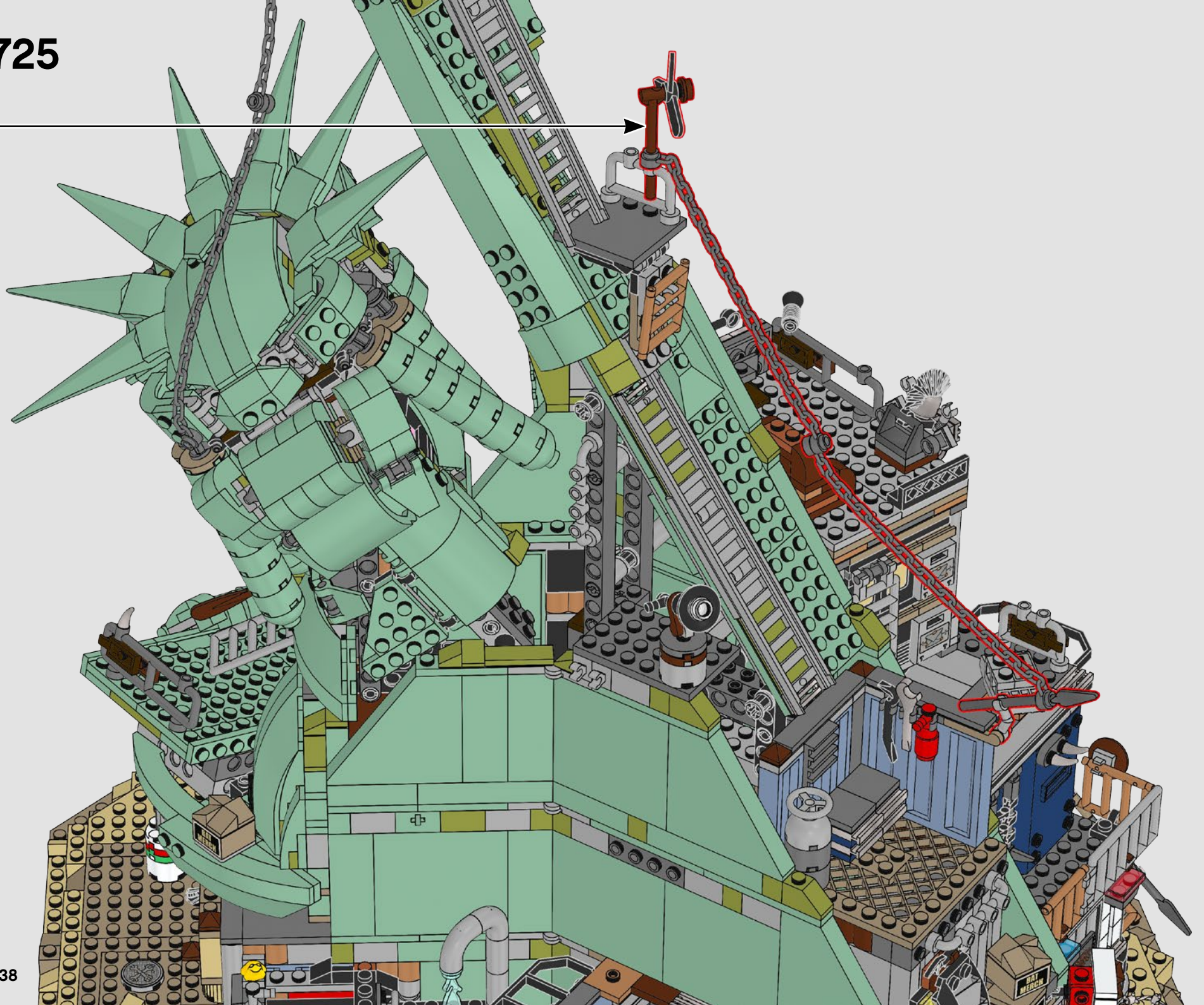

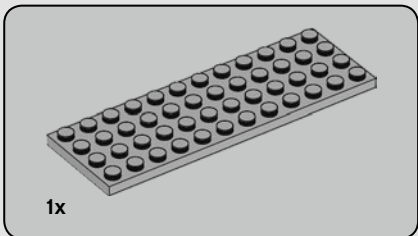

726

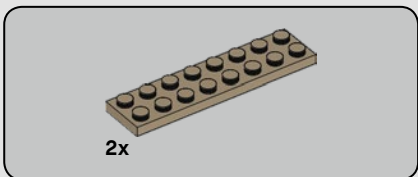
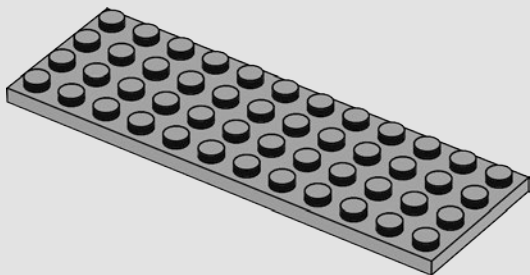

727

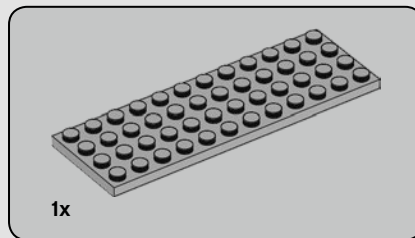
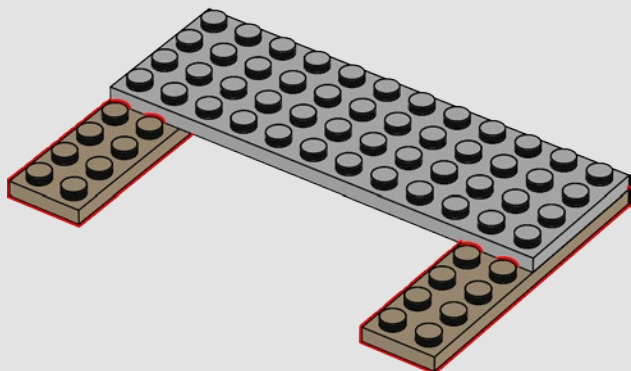

728

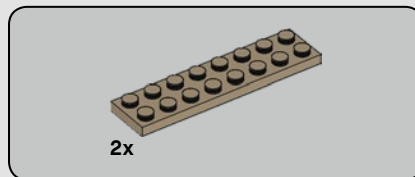
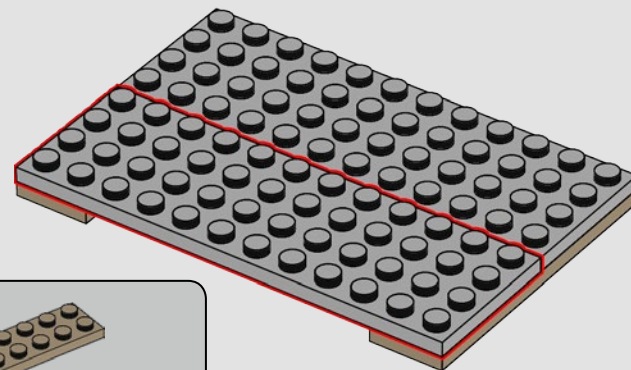

729

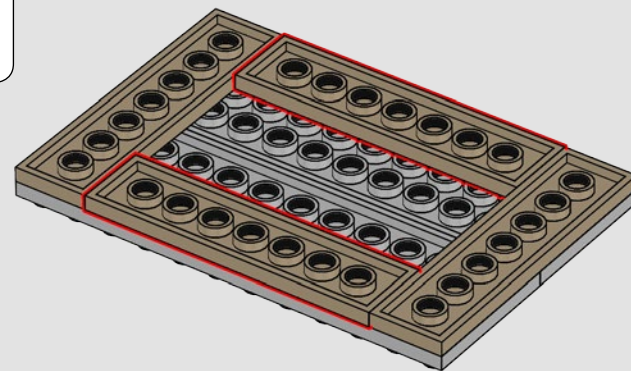
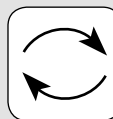

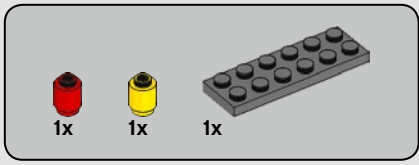

730

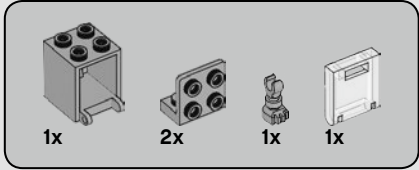
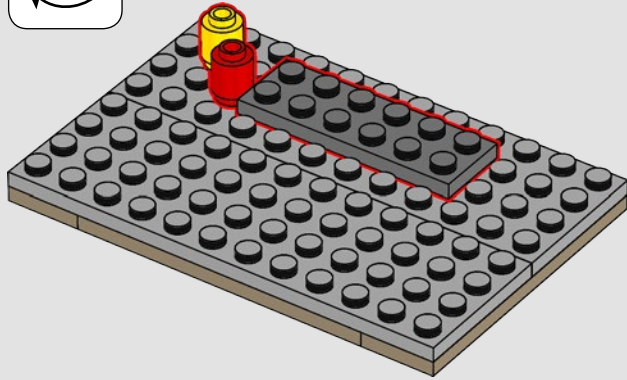
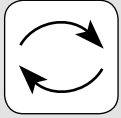

731

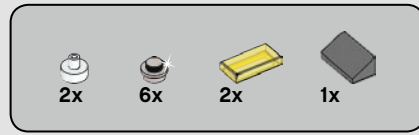
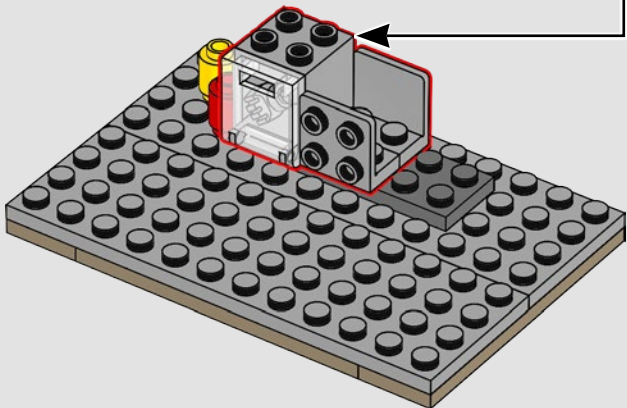
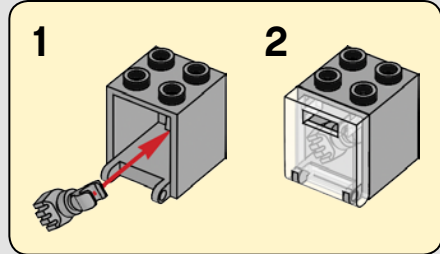

732

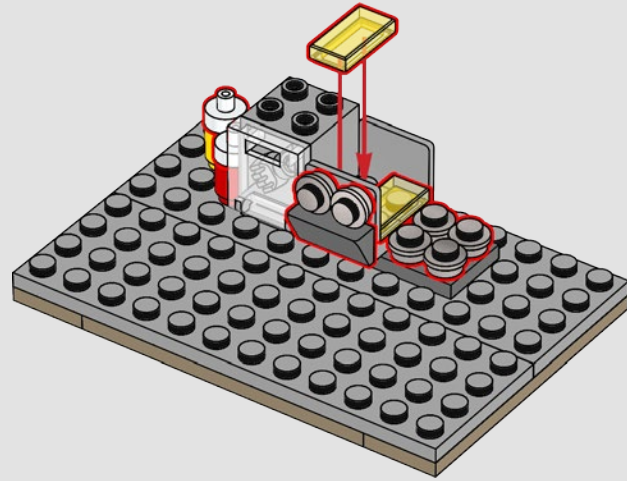

733

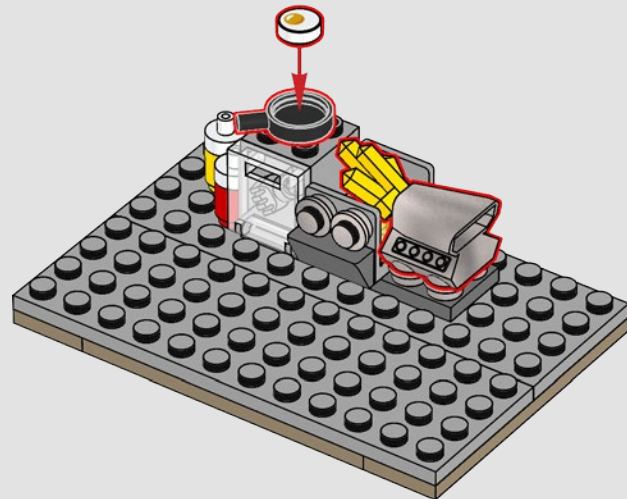



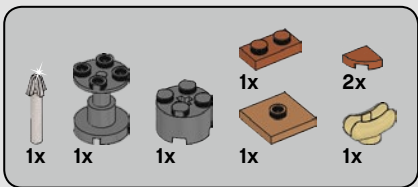

734

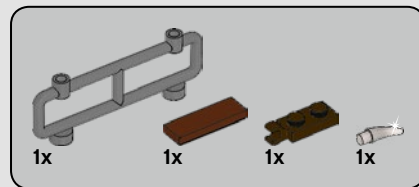
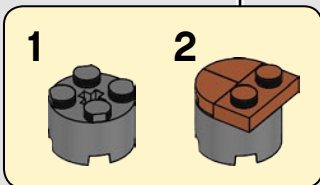
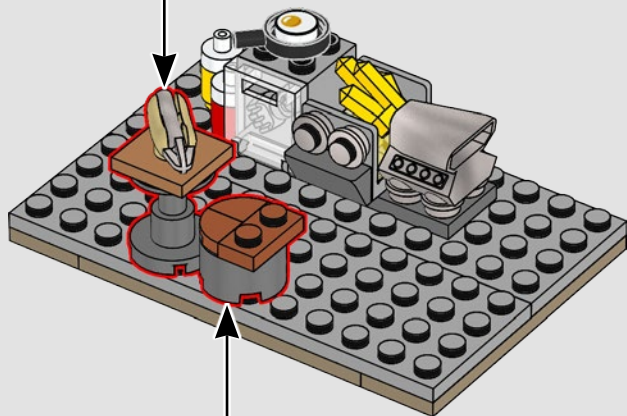
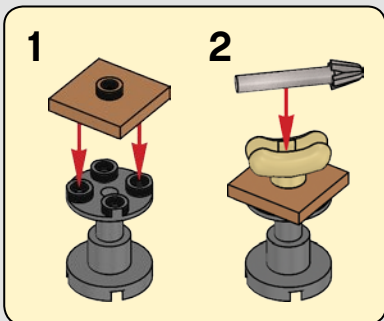

735

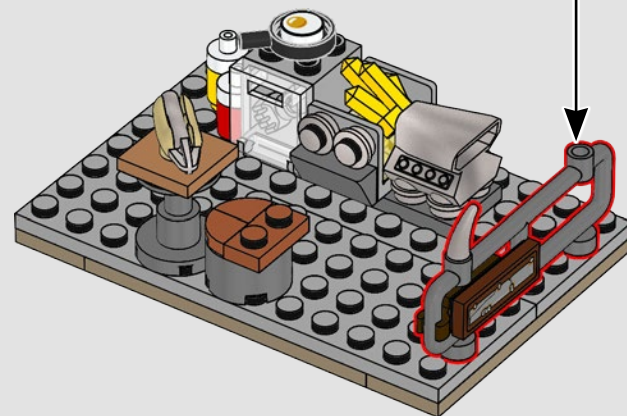
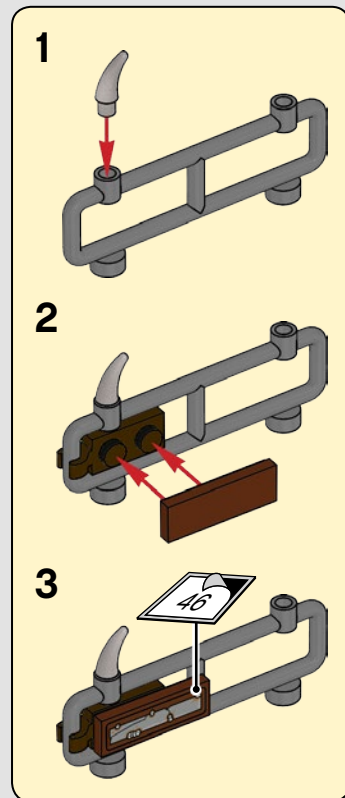

736

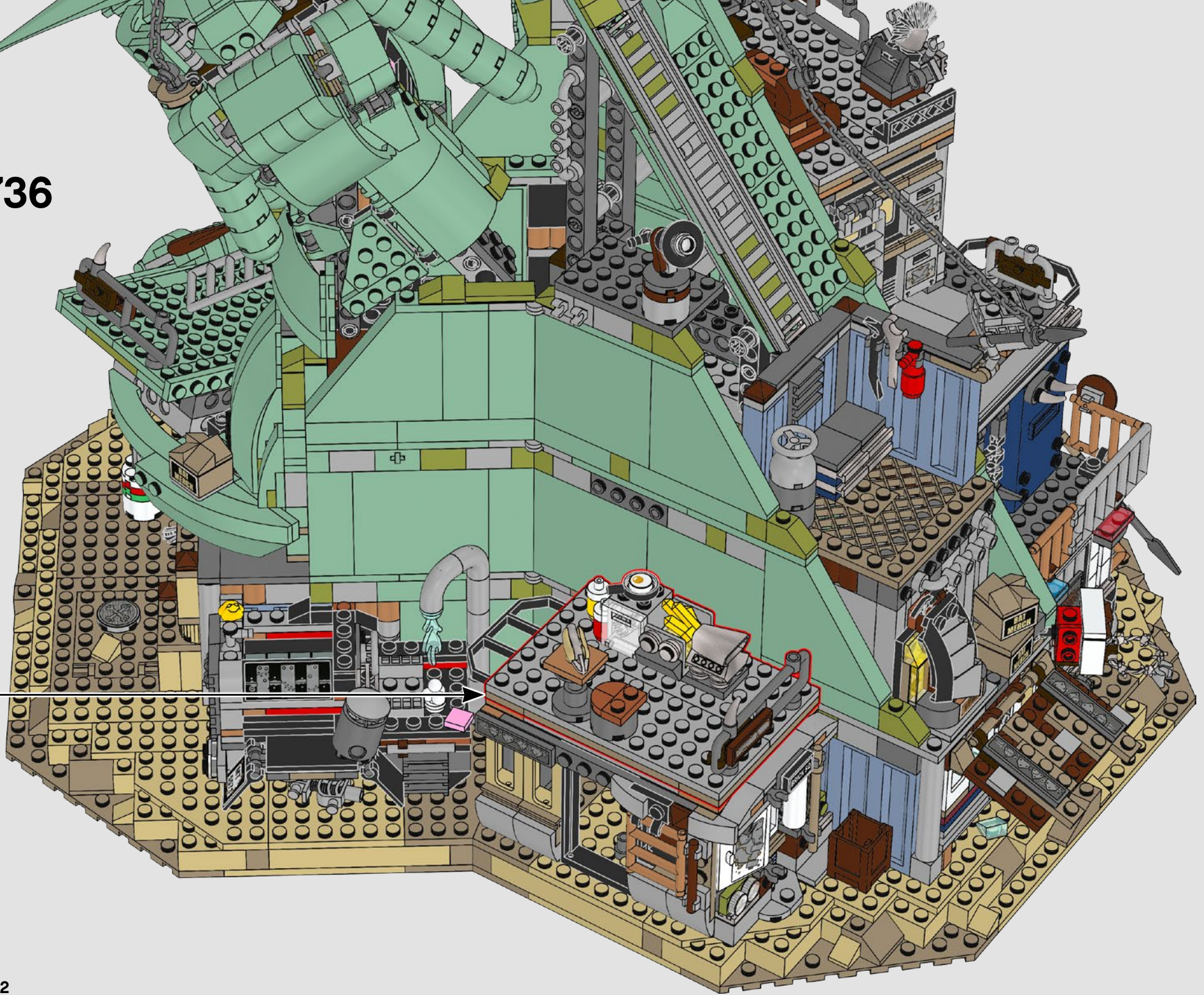

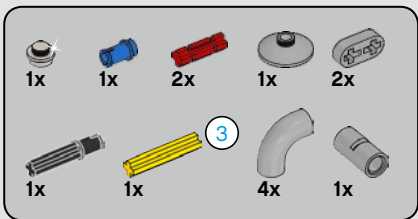

# 737

1

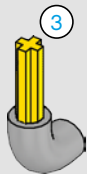

2

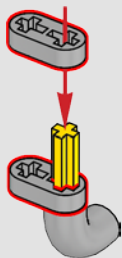

3

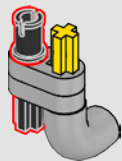

4

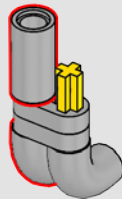

5

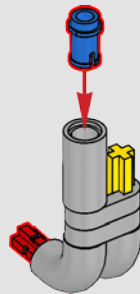

6

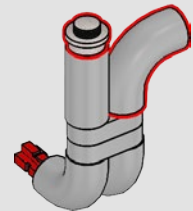

7

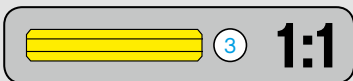
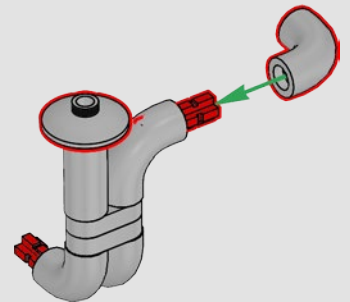

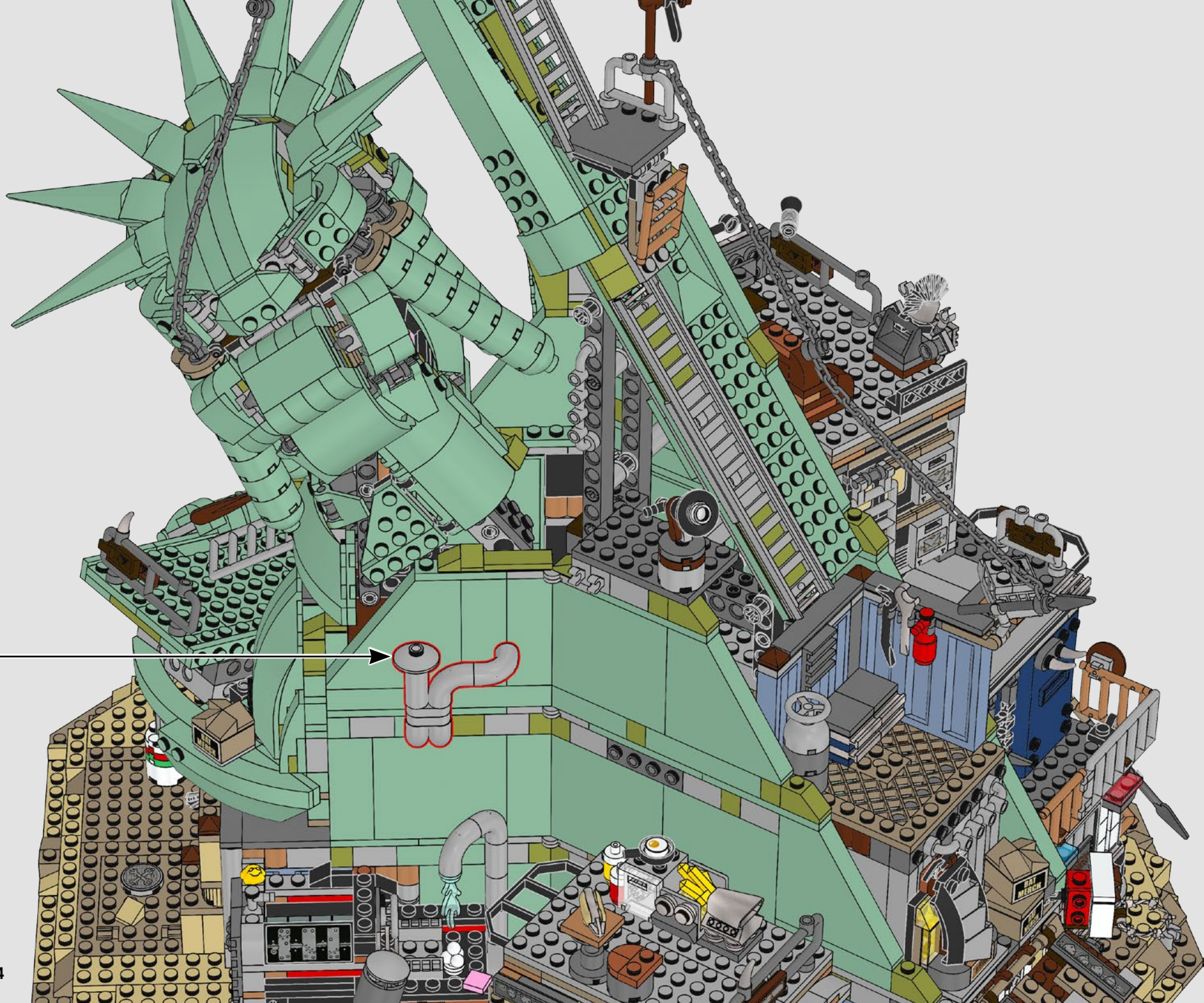



738

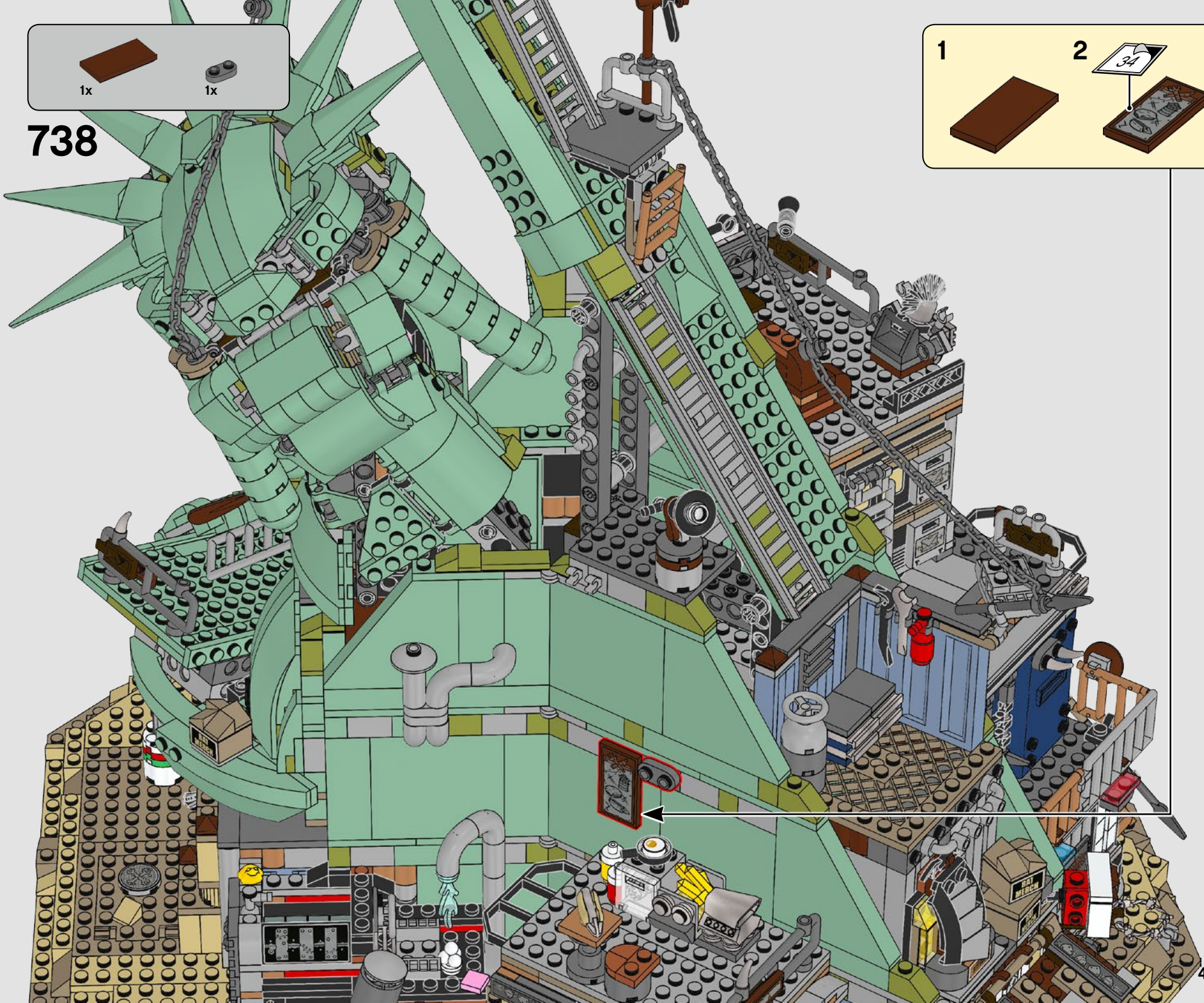
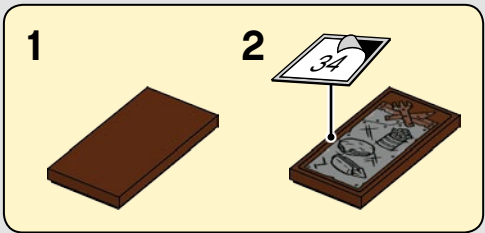

739

- 2x
- 1x
- 1x
- 1x
- 2x
- 1x
- 1x
- 1x
- 1x
- 1x
- 1x
- 1x

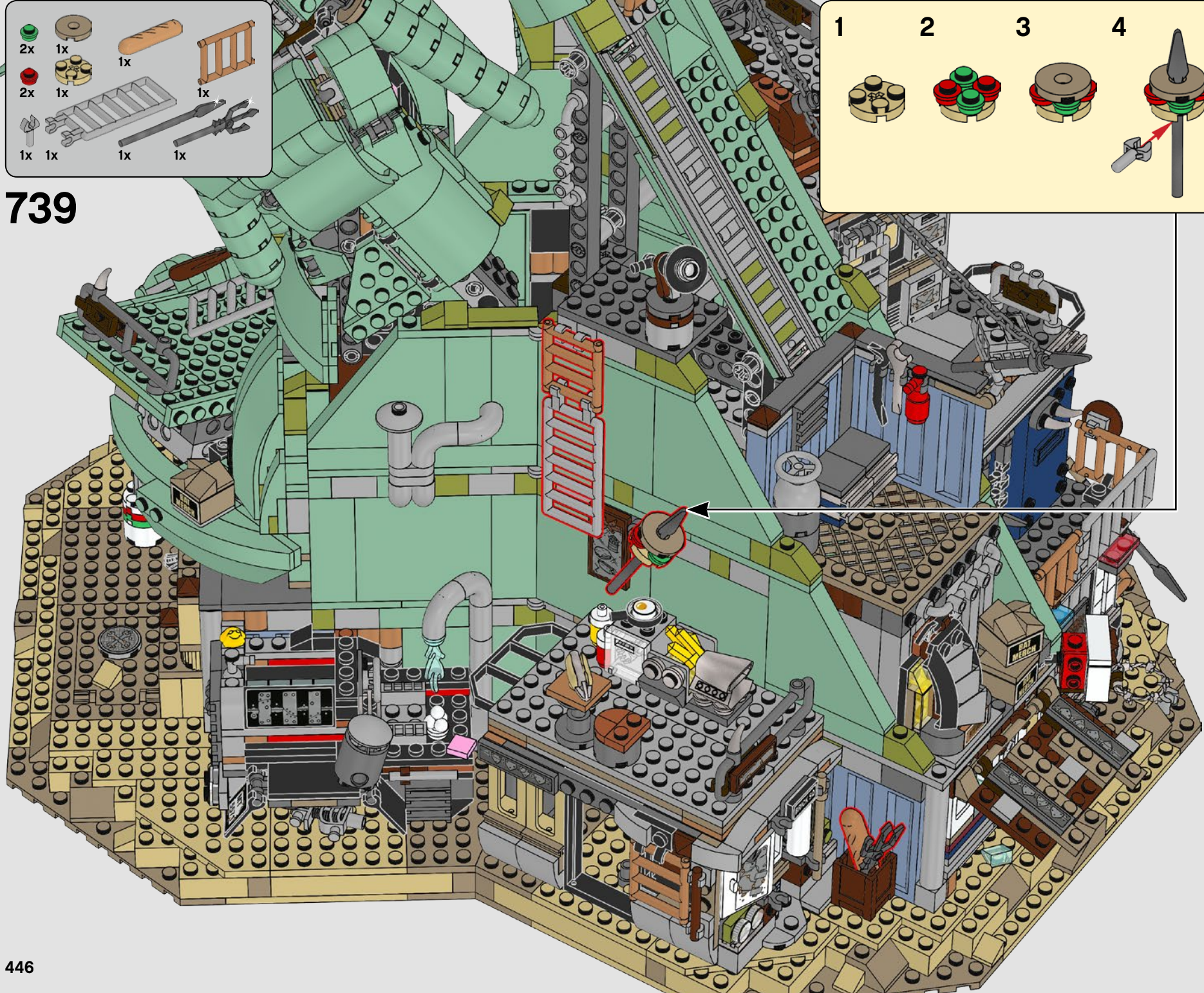
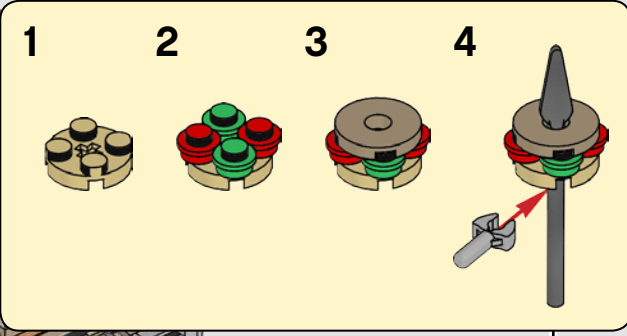

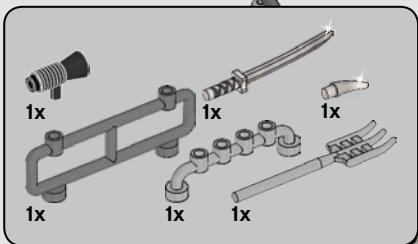

740

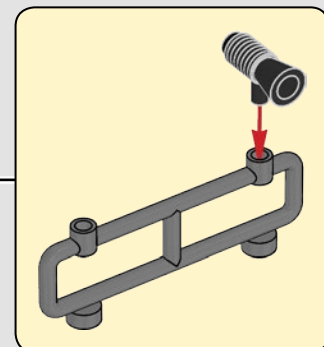
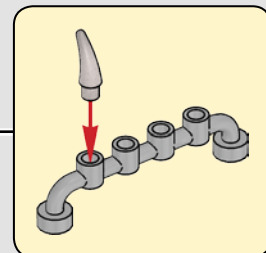
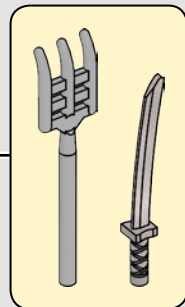
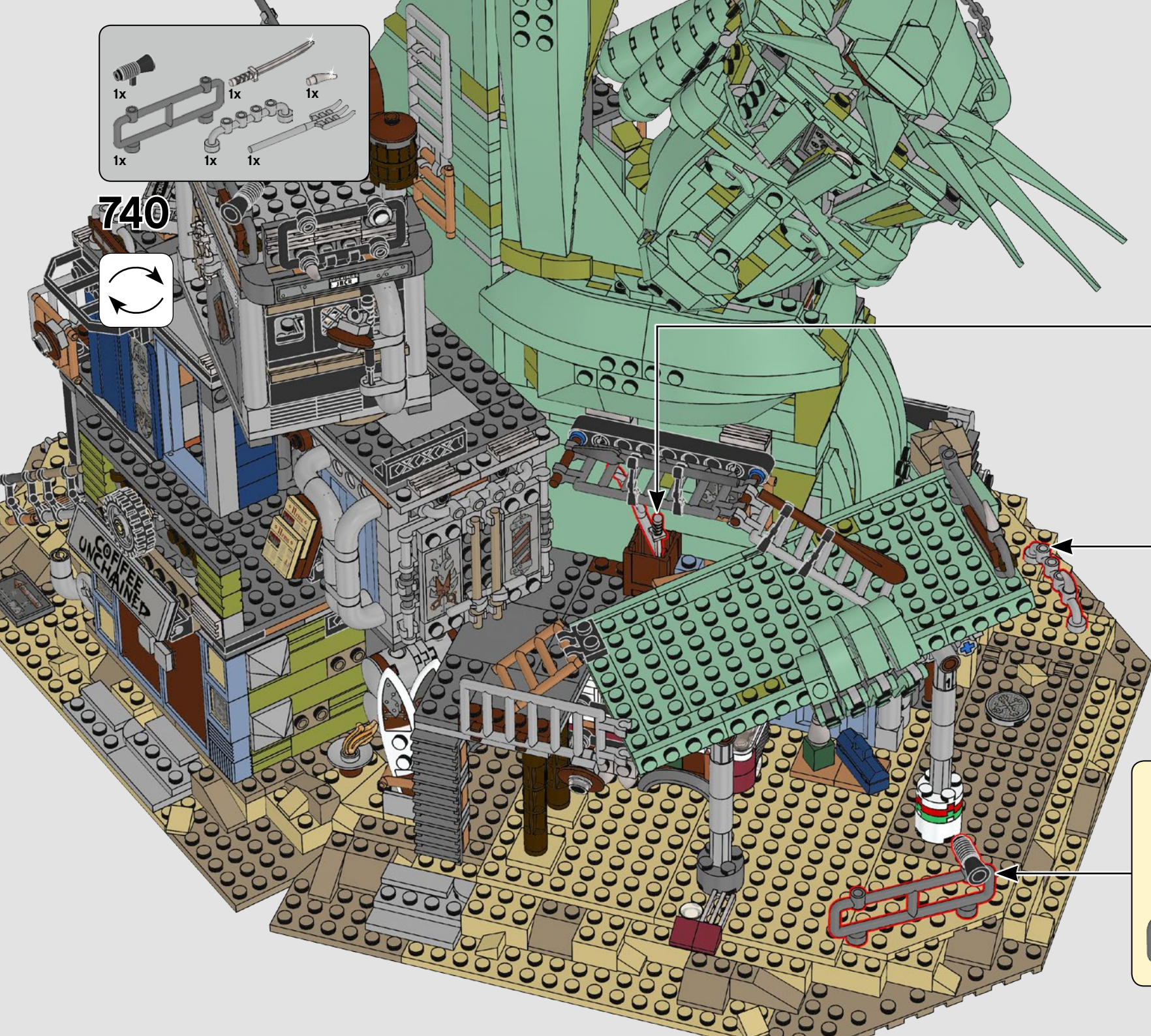

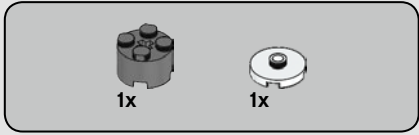

741

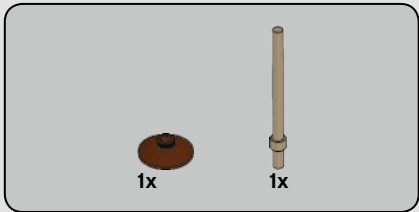
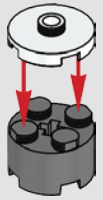

742

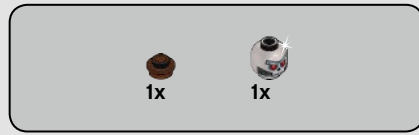
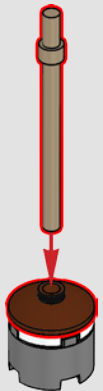

743



744

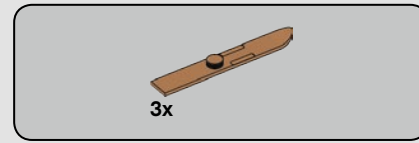

745

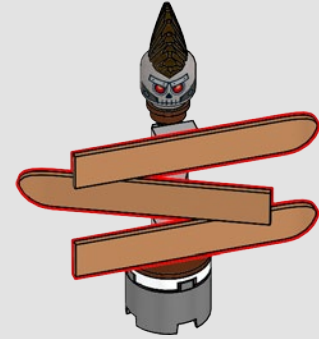

746





747

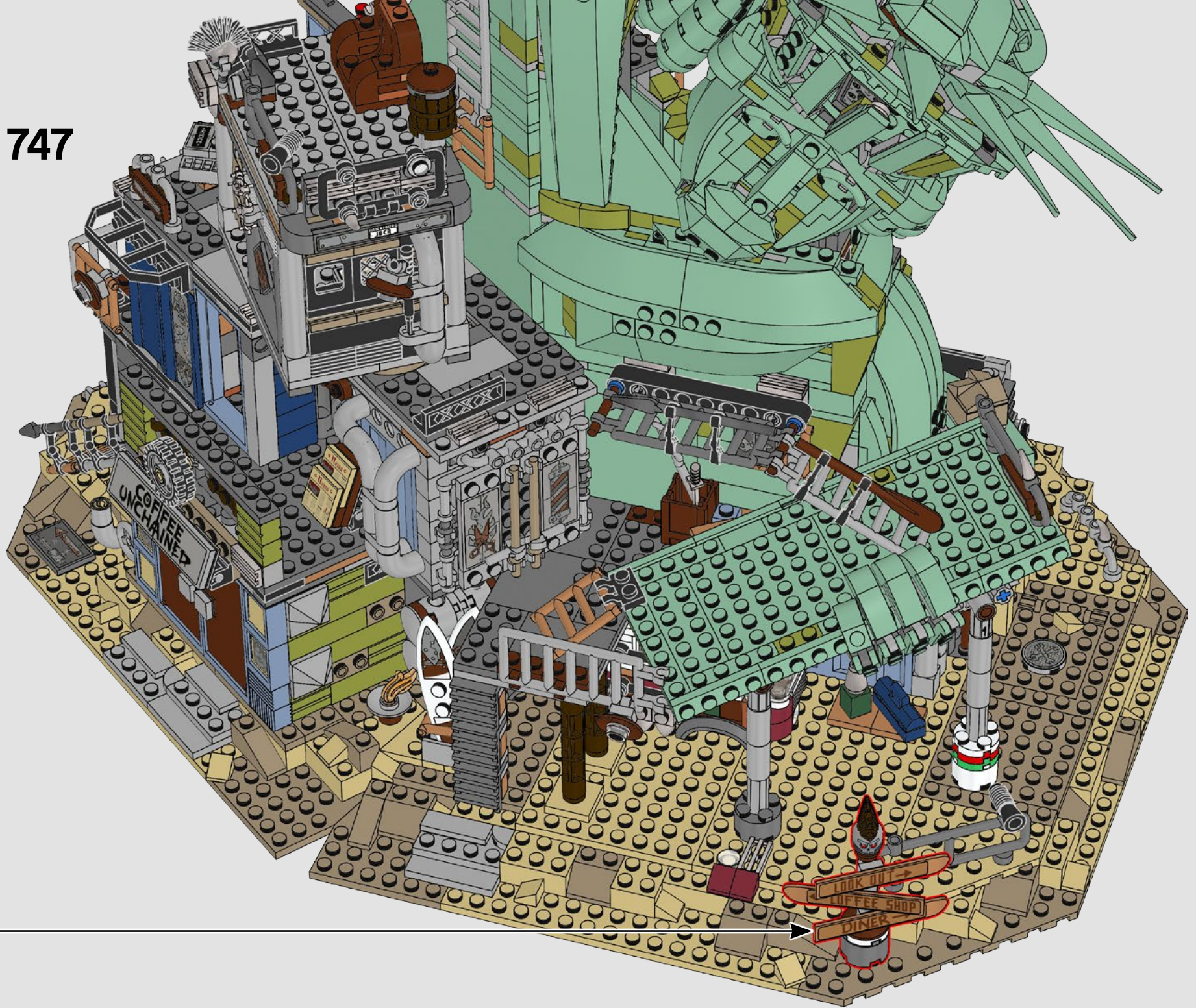

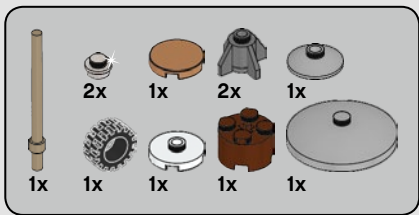

748

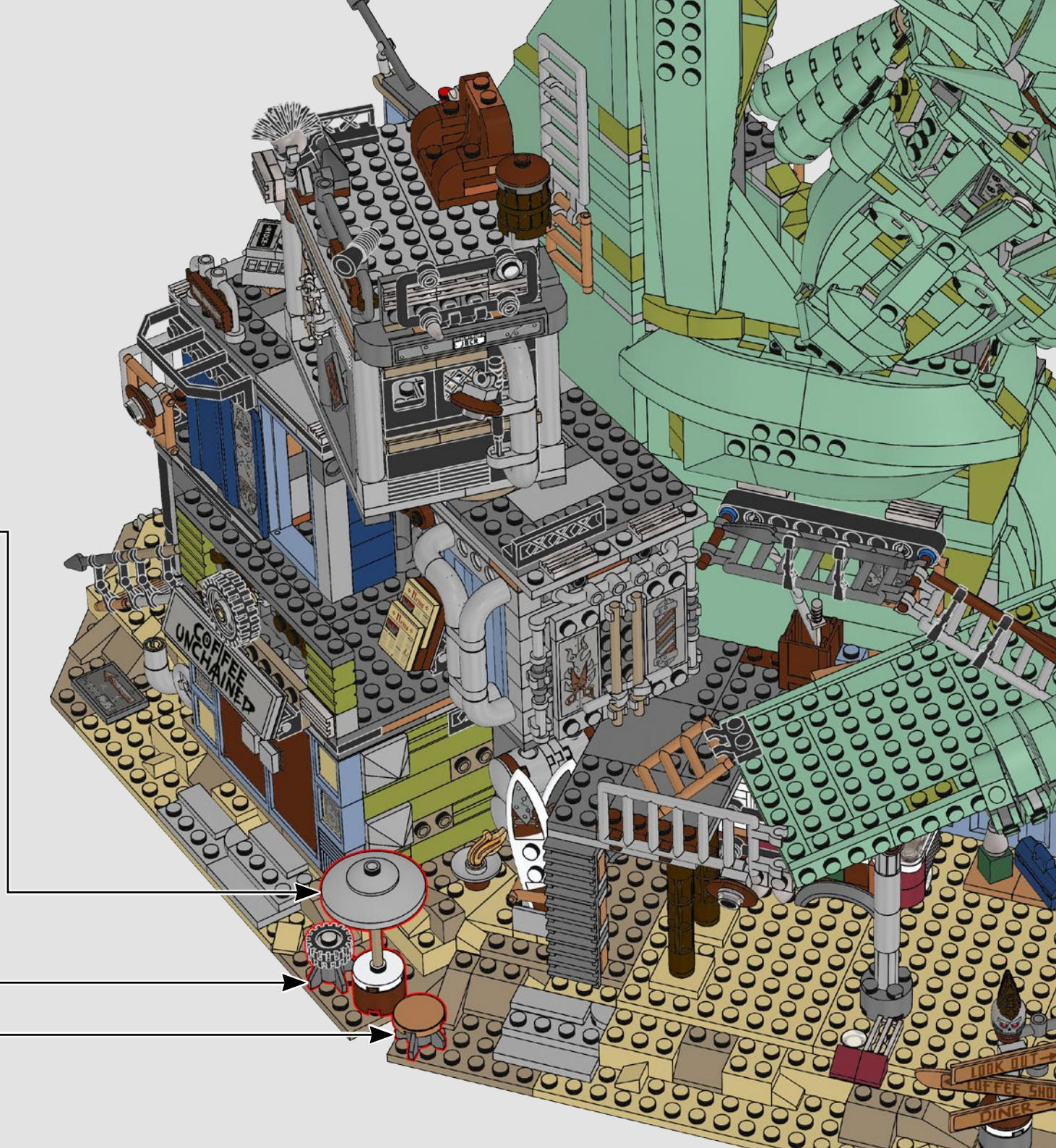
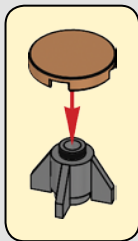
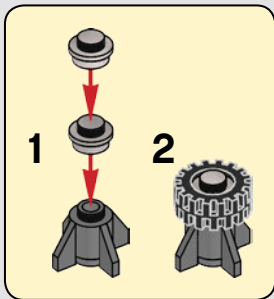
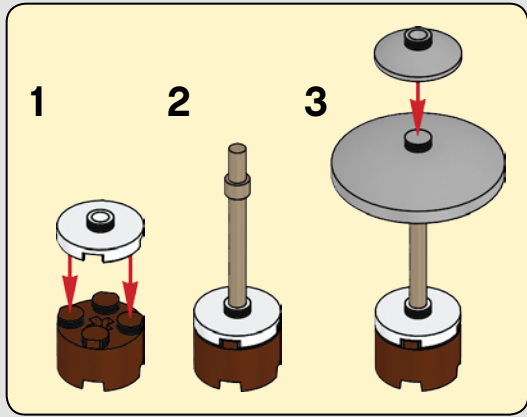

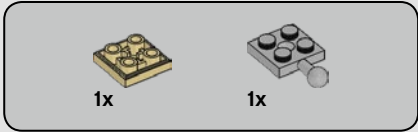
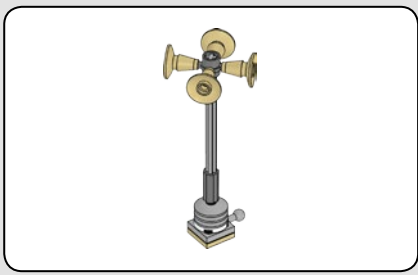

749

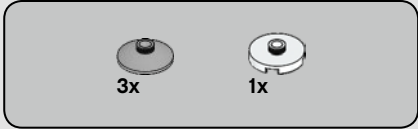
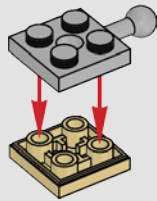

750

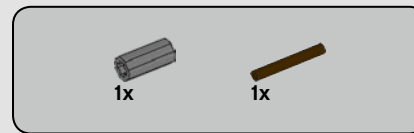
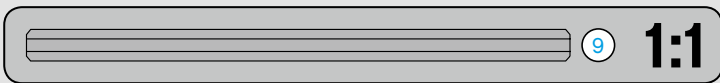
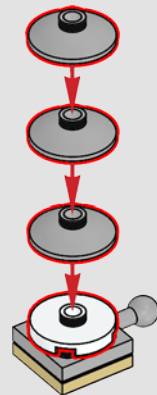

751

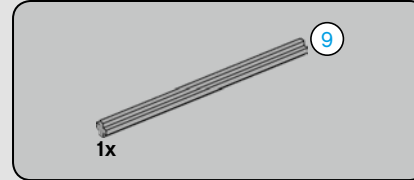
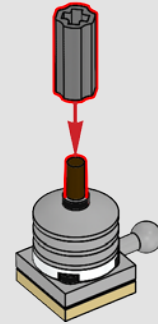

752

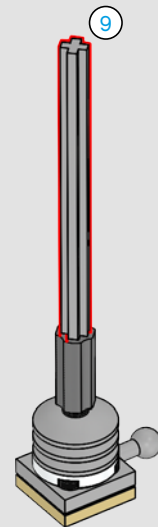



1x

753

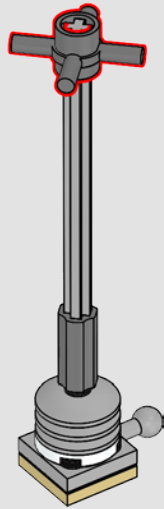

4x

754

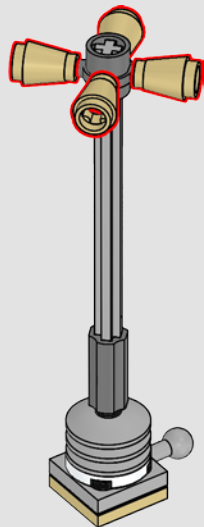

4x

755

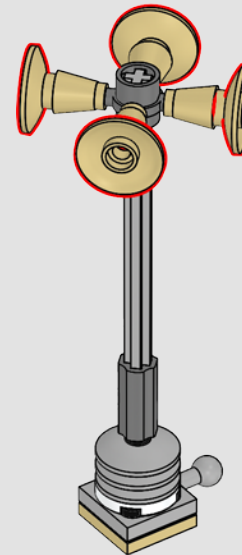

756

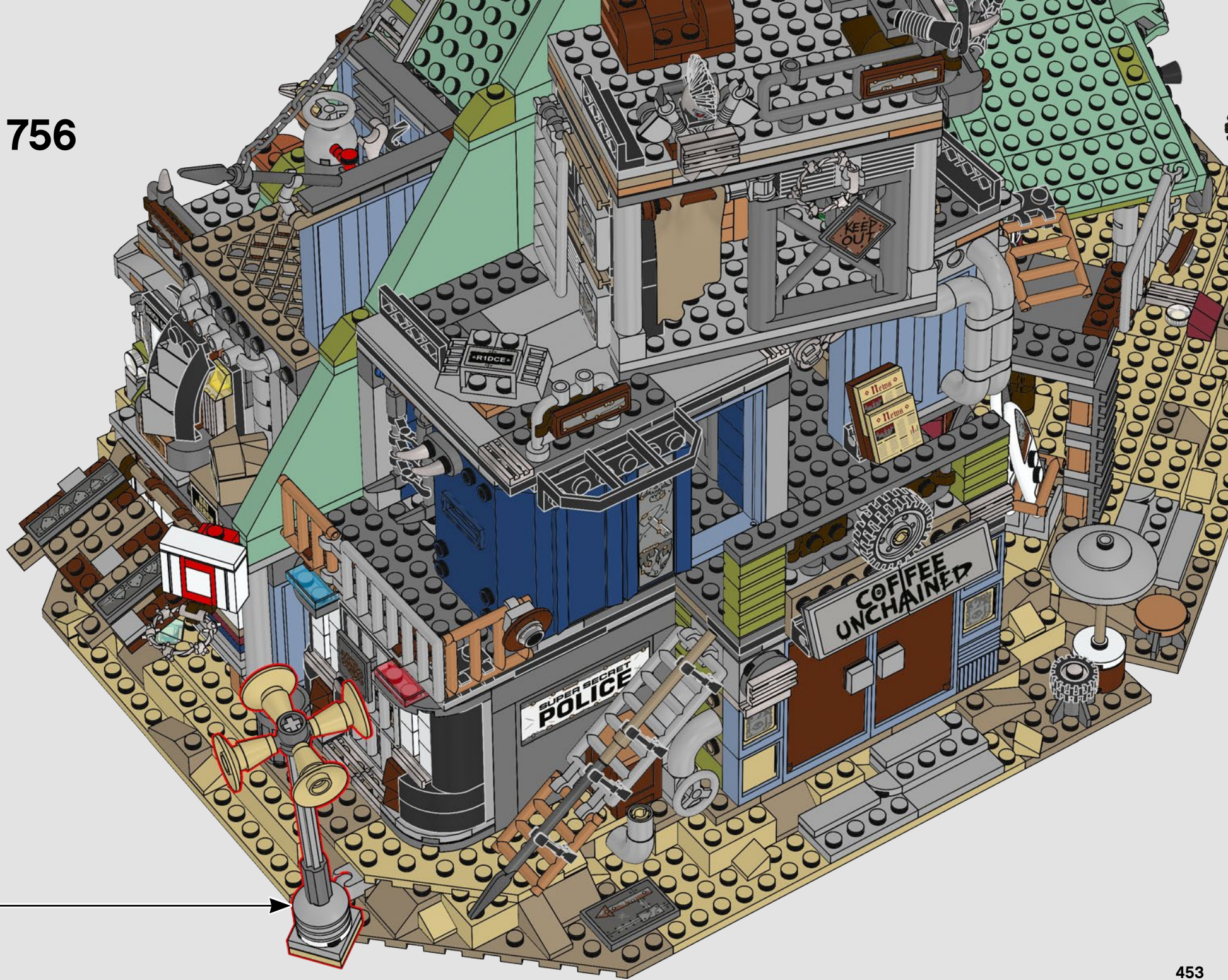





1



2



3

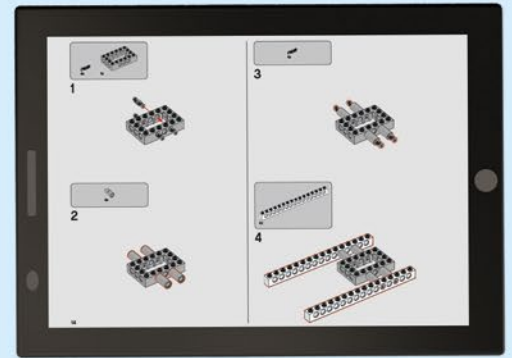



70823



70831

2 IN 1



70830



70829



70823

70829

70830

70831



7 LEGO.com/movie2

THE LEGO® MOVIE 2™ © & ™, Warner Bros. Entertainment Inc. & The LEGO Group. LEGO, the LEGO logo, DUPLO, the Minifigure and the Brick and Knob configurations are trademarks and/or copyrights of the LEGO Group. ©2019 The LEGO Group. All rights reserved. WB SHIELD: TM & © WBEI. (\$19)





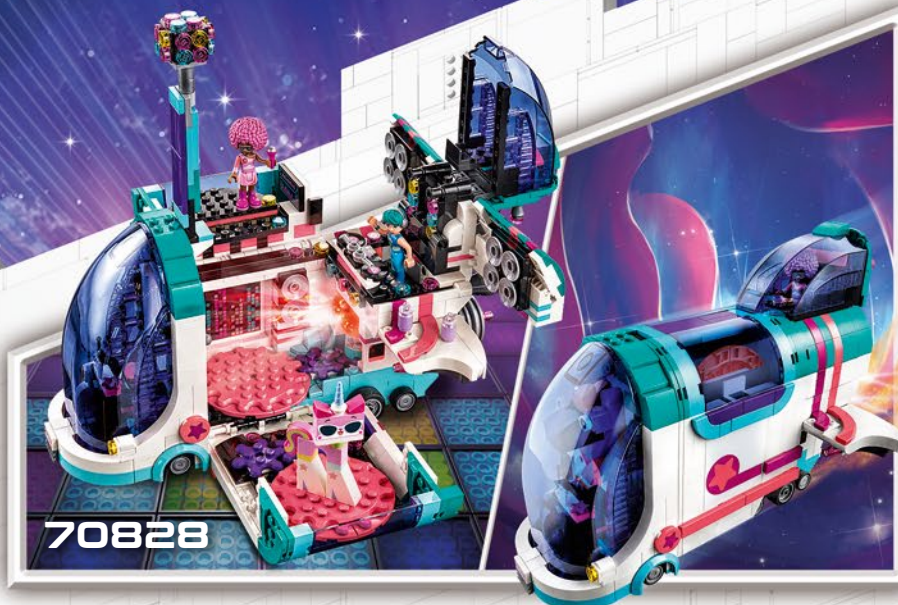

70828



70831



70830



70826



70826

70830

70831

70828



 [LEGO.com/movie2](http://LEGO.com/movie2)

THE LEGO® MOVIE 2™ © & ™, Warner Bros. Entertainment Inc. & The LEGO Group. LEGO, the LEGO logo, DUPLO, the Minifigure and the Brick and Knob configurations are trademarks and/or copyrights of the LEGO Group. ©2019 The LEGO Group. All rights reserved. WB SHIELD: TM & © WBEI. (s19)





# THE LEGO MOVIE VIDEOGAME

**CK3GR7**

**Unlock Model In Game**  
Separate purchase required

**Modèle à Déverrouiller  
En Jeu**  
Achat séparé requis

**Desbloquear Modelo  
En El Juego**  
Se requiere la compra por separado



PS4 PC

NINTENDO SWITCH XBOX ONE

RATING PENDING  
CÔTE EN ATTENTE  
**RP**  
ESRB  
Visit [esrb.org](http://esrb.org) for  
rating information  
Visiter [esrb.org](http://esrb.org)  
pour les classifications

LEGO GAMES

Tt  
games

WB  
GAMES

[LEGO.com/games](http://LEGO.com/games)

THE LEGO MOVIE 2 © & ™ The LEGO Group, DC Comics, WBEL, (s19)

3x 6052312  
 2x 6186681  
 2x 6209910  
 1x 625401  
 1x 6254211  
 4x 302401  
 2x 4558952  
 1x 300501  
 2x 6210272  
 1x 403201  
 3x 614301  
 3x 6093053  
 1x 4507685  
 6x 4264360  
 2x 6051511  
 1x 4536521  
 2x 306901  
 2x 302301

6x 4521210  
 1x 4519345  
 1x 6254023  
 2x 6218822  
 1x 6126046  
 1x 306801  
 2x 6238334  
 3x 366001  
 1x 4519346  
 1x 6195371  
 2x 4558168  
 1x 4521846  
 2x 6078168  
 2x 6184866

1x 4261565  
 1x 6062279  
 2x 383201  
 4x 4508661  
 4x 4529237  
 2x 6252969  
 22x 4516055  
 9x 6256080  
 1x 6175968  
 1x 6013938  
 1x 6138230  
 1x 6228984  
 1x 6147214  
 1x 4140562

1x 4666579  
 2x 4650647  
 4x 4617765  
 6x 4159279  
 2x 4205107  
 2x 6261357  
 4x 4612873  
 2x 6135300  
 1x 6013081  
 3x 6187580  
 23x 4159739  
 1x 4113233  
 2x 6031057  
 5x 4113988  
 11x 6037398

4x 6036485  
 2x 4143409  
 2x 4624223  
 3x 4624185  
 7x 4609726  
 2x 306221  
 2x 614121  
 1x 459921  
 6x 4142865  
 9x 403221  
 1x 614321  
 1x 6132541  
 1x 6001806

1x 6117974  
 1x 6209519  
 3x 371021  
 12x 300121  
 1x 6130004  
 16x 4143005  
 17x 4206482  
 6x 4514553  
 8x 3000023  
 1x 306224  
 1x 6171104  
 1x 6257920  
 1x 6253212  
 1x 6250922  
 1x 6261814  
 1x 6259767  
 1x 6256720

1x 6261738  
 1x 6253303  
 1x 6262010  
 7x 302424  
 1x 6194508  
 1x 6262150  
 2x 6119197  
 1x 6185994  
 1x 6171858  
 1x 6215043  
 1x 4175441  
 2x 6130007  
 1x 6266642  
 1x 6250952  
 1x 6262115  
 1x 6256733

3x 6130008  
 4x 4522935  
 1x 6221606  
 1x 6169986  
 1x 4538456  
 2x 306226  
 1x 6139403  
 2x 6158192  
 1x 459926  
 4x 4504382  
 3x 6234994  
 2x 6101834  
 1x 6014618  
 1x 6254435  
 1x 4184169  
 3x 4517925  
 1x 6055554

5

13

8

3

- 1x 6196548
- 1x 4550017
- 1x 4578677
- 1x 6251172
- 2x 6070695
- 1x 474026
- 66x 4121715
- 2x 6195325
- 1x 6022242
- 2x 452826
- 1x 6254136
- 1x 6262044
- 1x 4140430
- 1x 6253993
- 7x 287726
- 2x 4593678
- 6x 241226
- 460**
- 9x 4618852
- 4x 4569733
- 5x 4539128
- 12x 4223247
- 11x 370026
- 3x 306926
- 4x 366526
- 4x 393726
- 2x 434926
- 3x 6117973
- 2x 6016172
- 1x 6000650
- 9x 4556158
- 2x 6011815
- 1x 6195499
- 1x 6170693
- 3x 281726
- 2x 4163373
- 1x 6089119
- 11x 4140801
- 1x 4541455
- 2x 6138634
- 1x 6051038
- 4x 4618880
- 1x 6254155
- 1x 6251143
- 1x 6267085
- 2x 4650620
- 1x 6186698
- 1x 6043130
- 3x 265326
- 3x 6019726
- 12x 371026
- 5x 6254045
- 1x 301026
- 2x 4530589
- 2x 6254519
- 2x 6066113
- 2x 4535834
- 4x 4187209
- 1x 4189009
- 1x 4560182
- 4x 4188534
- 5x 4142135
- 1x 4525236
- 2x 6172984
- 5x 366626
- 1x 300926
- 1x 4243819
- 1x 4517986
- 2x 658326
- 1x 6187587
- 6x 370226
- 2x 4558850
- 1x 4645732
- 5
- 1x 4525236
- 2x 6172984
- 5x 366626
- 1x 300926
- 1x 4243819
- 1x 4517986
- 2x 658326
- 1x 6187587
- 6x 370226
- 2x 4558850
- 1x 4645732
- 9
- 3x 447726
- 4x 4188143
- 2x 370826
- 1x 389526
- 4x 244526
- 3x 303326
- 2x 4542573
- 2x 4569058
- 1x 403228
- 2x 306928
- 2x 4107736
- 7x 300328
- 4x 6228968
- 34x 4570877
- 1x 6151196
- 1x 6153264
- 7x 6240030
- 4x 4650498
- 2x 6238856
- 1x 6247357
- 1x 6251290
- 1x 6173640
- 1x 6167739
- 3x 6245277
- 4x 6252049
- 1x 6251289
- 2x 6245272
- 3x 6251291
- 3x 6240221
- 16x 4633822
- 6x 6258094
- 1x 6250965
- 8x 6143033
- 1x 6240515
- 2x 6244909
- 1x 6253684
- 1x 6245192
- 5x 6177135
- 4x 6149585
- 8x 6248968
- 1x 6262099
- 5x 4620993
- 2x 6111685
- 3x 6138708
- 9x 6258378
- 8x 6254772
- 12x 6040126
- 5x 6132790
- 1x 6015449
- 4x 6135609
- 1x 6226594
- 8x 4496699
- 3x 4528604
- 16x 4616711
- 33x 6047415
- 1x 6126075
- 13x 6184880
- 15x 4255416
- 3x 6135607
- 10x 6132768
- 7x 6015454
- 7x 6035540
- 12x 6001822
- 2x 6232138
- 1x 6015449
- 4x 6135609
- 1x 6226594
- 8x 4496699
- 3x 4528604
- 16x 4616711
- 33x 6047415
- 1x 6126075
- 13x 6184880
- 1x 4595709

15x  
6015424

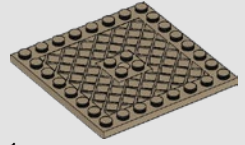
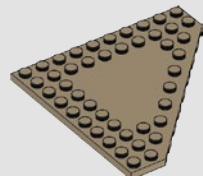

1x  
6141887

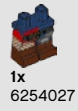

2x  
4502089



1x  
6129375



1x  
4616581



2x  
6202626



10x  
6075626

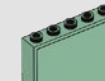
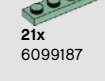
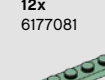
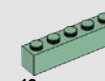

7x  
6258344

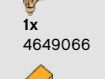
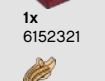
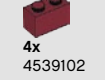
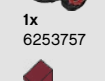
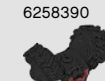
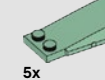
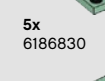
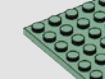
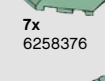

2x  
6034175

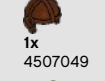
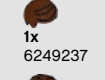
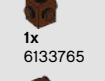
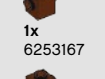
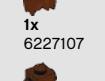
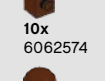
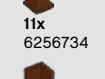
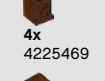
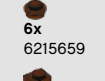
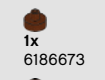
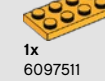
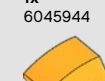
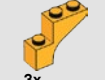

1x  
6248730

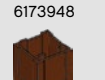
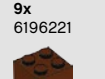
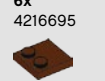
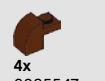
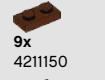
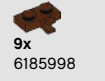
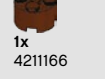
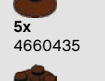
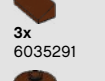
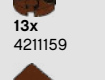

1x  
4211206

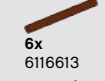
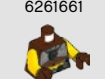
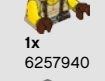
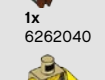
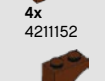

1x  
6198172

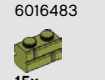
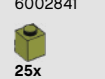
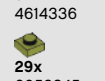

3

- 1x 4211157
- 4x 6035580
- 3x 4579690
- 3x 4211186
- 1x 6214343
- 4x 4270882
- 2x 6228841
- 1x 4609635
- 1x 4211207
- 4x 6004996
- 1x 6253969
- 2x 4539481
- 4x 6240497
- 12x 4211412
- 7x 4542590
- 4x 6252203
- 2x 6250597
- 4x 6183784
- 2x 4211550
- 2x 4211503
- 1x 4211483
- 9x 4179576
- 3x 6176433
- 5x 4211476
- 16x 6071229
- 2x 4211362
- 18x 4211415
- 1x 6061702
- 1x 4211465
- 1x 6252474
- 7x 4535764
- 8x 6225246
- 11x 4533772
- 6x 4211741
- 1x 4514195
- 2x 4211492
- 26x 6173127
- 16x 4278273
- 4x 6075075
- 4x 4211475
- 4x 6078985
- 4x 6092956
- 16x 6151349
- 6x 4211512
- 1x 6052200
- 1x 4211637
- 13x 4211526
- 1x 4632575
- 1x 4211553
- 3x 4653091
- 1x 4211814
- 2x 4512360
- 3x 6043656
- 5x 6028813
- 1x 6248492
- 4x 6028812
- 2x 4611702
- 1x 6186657
- 4x 6146223
- 30x 4211398
- 1x 4211414
- 2x 4211437
- 2x 6227184
- 8x 4598526
- 2x 4211519
- 2x 6168633
- 7x 6015344
- 6x 6066097
- 1x 4211541
- 2x 4582153
- 24x 6123809
- 3x 4654580
- 1x 6044729
- 1x 4556157
- 2x 4211644
- 2x 6212086
- 1x 4641048
- 2x 4563045
- 10x 4244627
- 18x 4535738
- 1x 4211660
- 1x 6093257
- 10x 4558169
- 1x 4282786
- 1x 4610149
- 9x 4211529
- 2x 6133587
- 1x 6256657
- 4x 6093058
- 1x 4527767
- 5x 4211613
- 3x 6061675
- 1x 4211491
- 1x 4211664
- 2x 4211748
- 12x 6102769
- 1x 6247352
- 7x 4211395
- 18x 4560183
- 4x 4211524
- 2x 6079461
- 5x 4211393
- 8x 4211438
- 2x 4527174
- 1x 6228920
- 2x 4211795
- 2x 4565430
- 3x 4211425
- 15x 4211481
- 5x 4211716
- 3x 4211838
- 7x 4275673
- 1x 4535768
- 2x 4211374
- 1x 4211407
- 1x 4211462
- 14x 4617862
- 1x 4211408
- 3x 4211860
- 2x 4211402
- 2x 4522934
- 8x 4211401
- 1x 4211400
- 6x 4211443
- 2x 6055013
- 8x 6015890
- 1x 6166069
- 2x 6207934
- 2x 6199549
- 4x 4210690
- 1x 4210469

- 1x 6158469
- 3x 4212352
- 4x 6063616
- 4x 6020189
- 2x 4579354
- 2x 6221607
- 13x 4587212
- 1x 6116470
- 1x 4567887
- 1x 6170695
- 3x 6106283
- 3x 6115080
- 5x 4249139
- 1x 4161673
- 8x 4211095
- 1x 4516546
- 1x 4210892
- 1x 6261665
- 3x 6127738
- 2x 4210762
- 4x 4210797
- 3x 4211052
- 3x 6039479
- 4x 4211075
- 1x 4210763
- 23x 6000606
- 8x 4603504
- 3x 4211128
- 11x 4210660
- 1x 4222192
- 7x 6123814
- 2x 6013082
- 3x 4211055
- 3x 4211129
- 1x 6066952
- 2x 6177079
- 3x 4211109
- 2x 6227909
- 11x 4210635
- 2x 6015356
- 1x 4210884
- 1x 4524930
- 1x 4246896
- 1x 4211080
- 1x 6171068
- 3x 6086709
- 4x 6118832
- 6x 6231853
- 2x 4582257
- 4x 6187008
- 2x 4211105
- 6x 4211024
- 2x 6170503
- 14x 4211053
- 10x 4210725
- 1x 6150297
- 2x 4211007
- 1x 4211127
- 3x 6039176
- 4x 4212075
- 11x 4211065
- 2x 4210718
- 3x 4210917
- 3x 4542618
- 12x 4210651
- 5x 4505068
- 9x 4509911
- 5x 4539429
- 4x 4210728
- 1x 6039699
- 1x 6138633
- 17x 4211002
- 5x 6062482
- 7x 4211099
- 1x 4211115
- 4x 4499858
- 1x 6187438
- 1x 4667977
- 2x 4257526
- 2x 4603472
- 8x 6133611
- 1x 4210798
- 2x 4210963
- 2x 4211122
- 2x 4211137
- 2x 4542576
- 8
- 4x 4516456
- 2x 4210720
- 1x 6195347
- 1x 6251940
- 7x 4286050
- 1x 4550359
- 1x 6262135
- 2x 6147004
- 1x 6177318
- 1x 6254166
- 1x 6254215
- 2x 6133832
- 2x 6253910
- 1x 6158322
- 1x 4536677
- 4x 4516456
- 6063616
- 4210720
- 6195347
- 6251940
- 4286050
- 4550359
- 6262135
- 6147004
- 6177318
- 6254166
- 6254215
- 6133832
- 6253910
- 6158322
- 4536677
- 11
- 2x 6258056
- 1x 6251155
- 1x 4518557
- 9x 6141589
- 2x 6199910
- 7x 6046939
- 2x 6211448
- 20x 6215606
- 5x 4569385
- 2x 6173694
- 24x 4651231
- 1x 6021997
- 18x 6102994
- 11x 6167599
- 1x 4622738
- 3x 6093494
- 1x 6035734
- 3x 6258689
- 2x 6162578
- 1x 6121350
- 42x 4633691
- 1x 6153590
- 1x 6096993
- 6x 6261653
- 2x 6258056
- 1x 6251155
- 1x 4518557
- 9x 6141589
- 2x 6199910
- 7x 6046939
- 2x 6211448
- 20x 6215606
- 5x 4569385
- 2x 6173694
- 24x 4651231
- 1x 6021997
- 18x 6102994
- 1x 6161155
- 1x 6198173
- 5x 4625146
- 7x 4612901
- 33x 4619636
- 7x 6132264
- 3x 6158405
- 2x 6244688
- 1x 6076604
- 2x 6203202
- 1x 6167576
- 6x 6261653
- 10x 4655256
- 1x 6051870
- 1x 6257792
- 1x 6158368
- 2x 6248797
- 1x 6257805
- 1x 6257796
- 1x 4617248
- 1x 6257802



**Customer Service**  
**Kundenservice**  
**Service Consommateurs**  
**Servicio Al Consumidor**  
**LEGO.com/service or dial**

**: 00800 5346 5555**  
**: 1-800-422-5346**

# WIN

GO TO [WWW.LEGO.COM/PRODUCTFEEDBACK](http://WWW.LEGO.COM/PRODUCTFEEDBACK) AND  
GIVE US YOUR SHORT **FEEDBACK** ABOUT THIS  
LEGO® SET FOR A CHANCE TO WIN  
A COOL LEGO PRIZE.

Terms & Conditions apply

## [LEGO.com/productfeedback](http://LEGO.com/productfeedback)



### GEWINNE

Erzähle uns auf  
[www.LEGO.com/productfeedback](http://www.LEGO.com/productfeedback)

etwas über die Erfahrungen, die du  
mit diesem LEGO® Set gemacht hast,  
und sichere dir die Chance auf einen  
coolen LEGO Preis!

Es gelten die Teilnahmebedingungen

### GAGNE

Rends-toi sur  
[www.LEGO.com/productfeedback](http://www.LEGO.com/productfeedback)

et donne-nous quelques commen-  
taires sur ce produit LEGO® pour  
avoir une chance de gagner un prix  
LEGO !

Voir Conditions Générales

### GANAN

Visita  
[www.LEGO.com/productfeedback](http://www.LEGO.com/productfeedback)

y envíanos tu opinión acerca de este  
set LEGO®. ¡Participarás en el sorteo  
de un premio LEGO!

Términos y Condiciones aplicables

### 获取奖品

登录  
[www.LEGO.com/productfeedback](http://www.LEGO.com/productfeedback)

给出关于此乐高®套装的简短反馈，  
就有机会获得炫酷乐高奖品

《条款及条件》适用

THE LEGO® MOVIE 2™ © & ™ DC Comics, Warner Bros. Entertainment Inc. & The LEGO Group. LEGO, the LEGO logo, DUPLO, the Minifigure and the Brick and Knob configurations are trademarks and/or copyrights of the LEGO Group.  
©2019 The LEGO Group. BATMAN and all related characters and elements © & ™ DC Comics. All rights reserved. WB SHIELD: TM & © WBEI. (s19)

