



CREATOR

6747



1

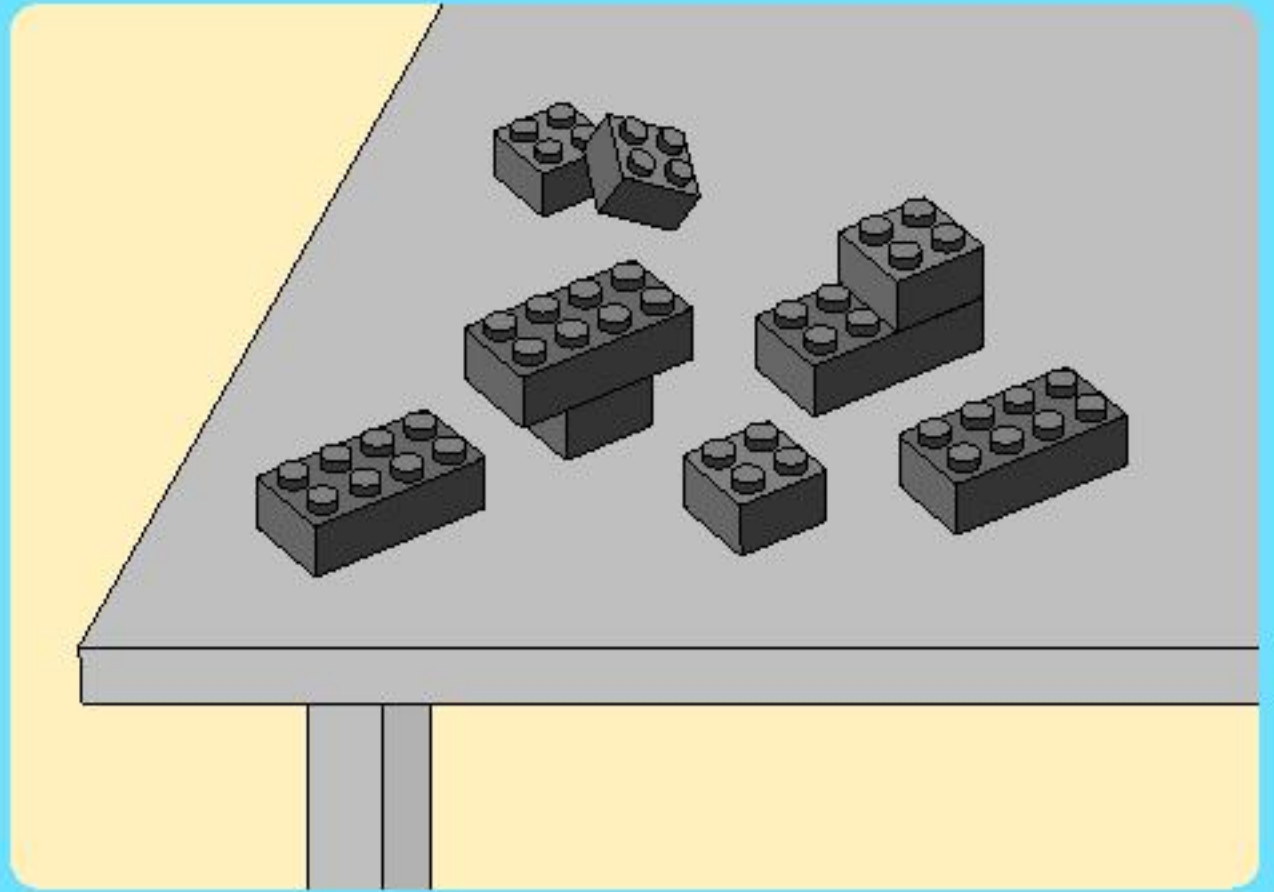
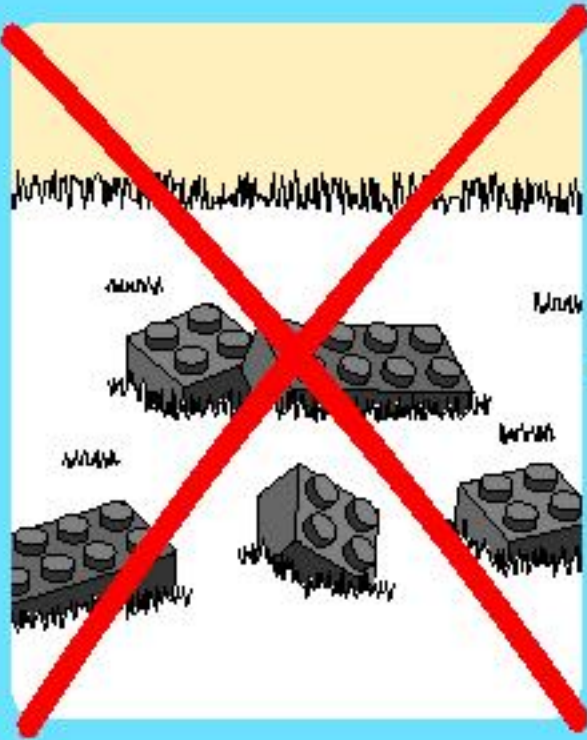

2





1

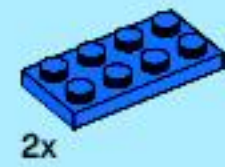
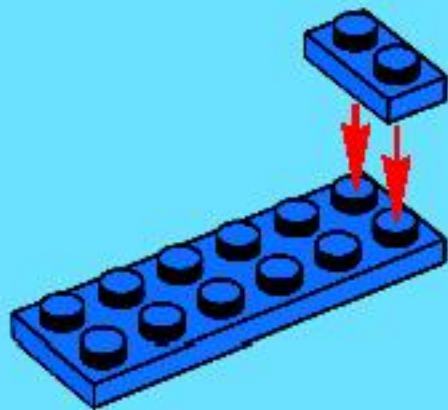

2

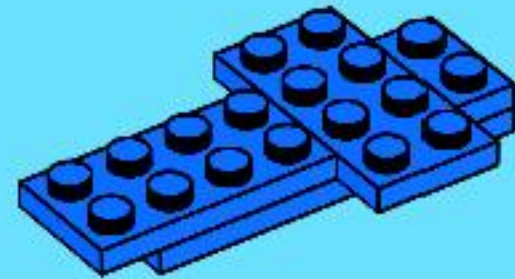

3

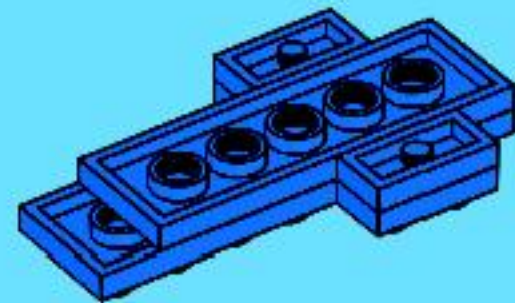



2x



1x

4

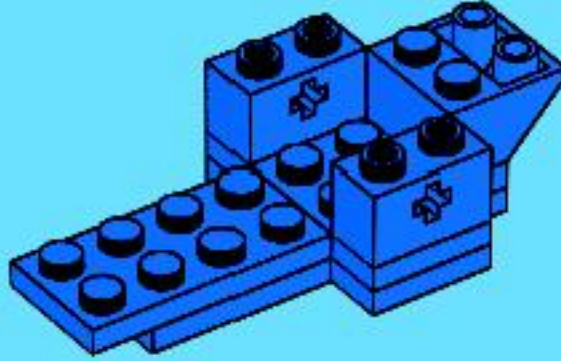

4x

5

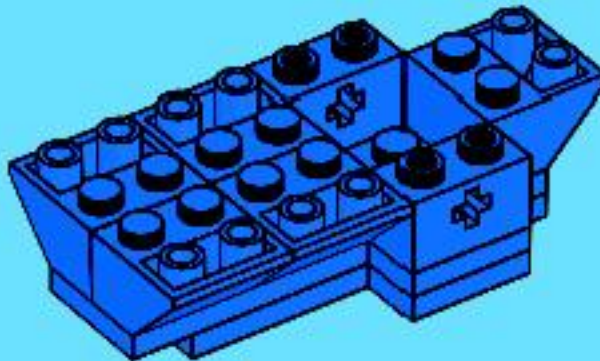



1x

6

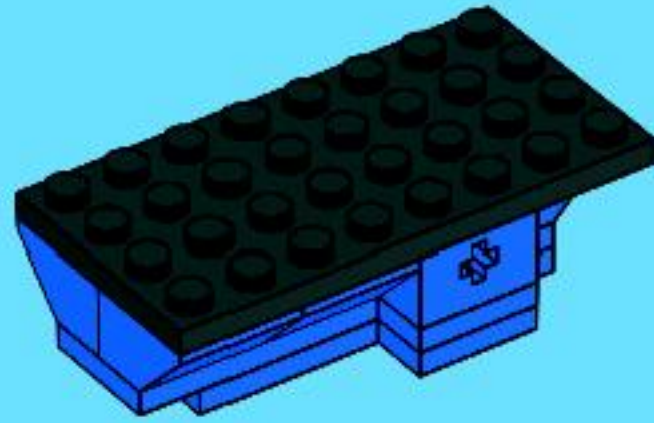

1x



1x

7

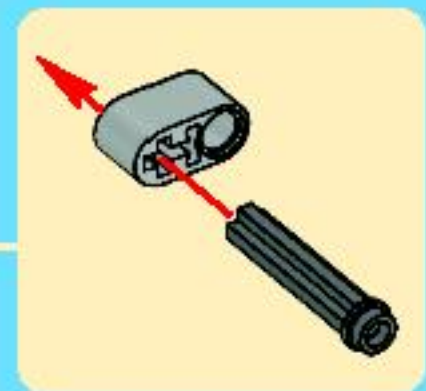
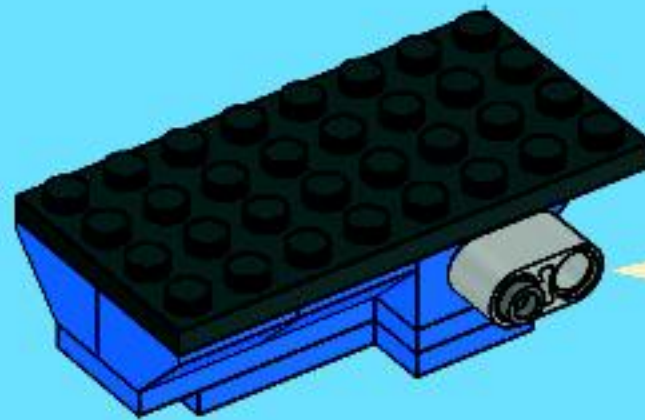



1x



1x



1x

8

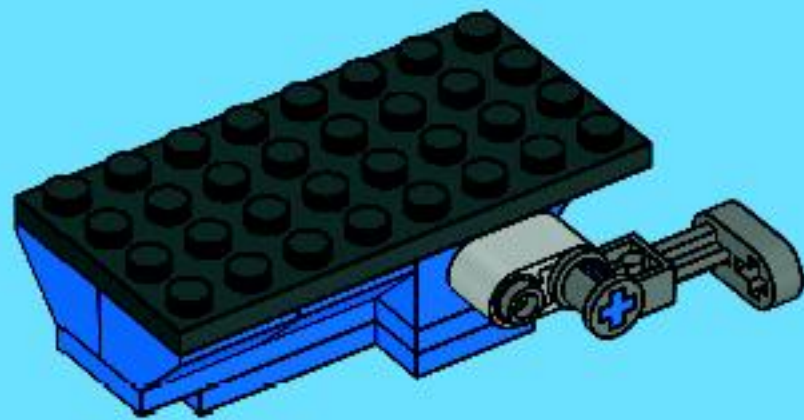

1

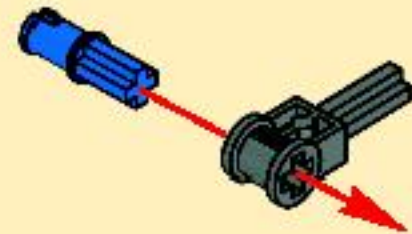

2



4x



2x

9

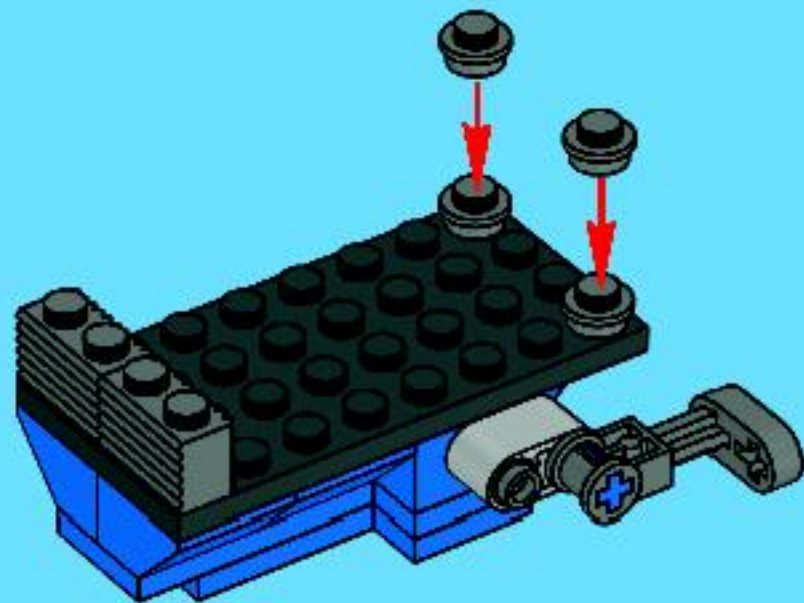



2x

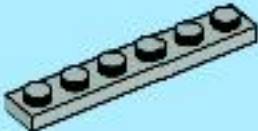

1x

10

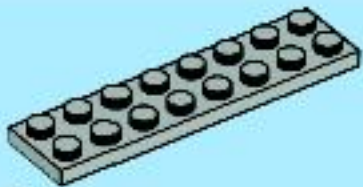
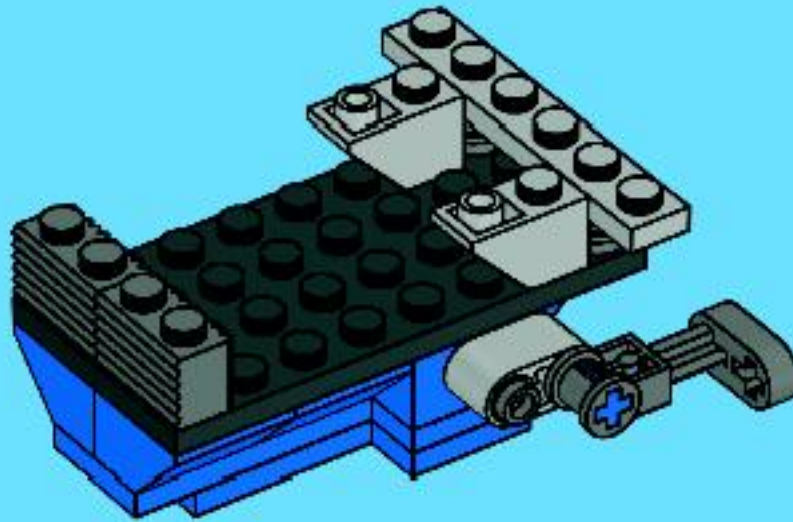

2x

11

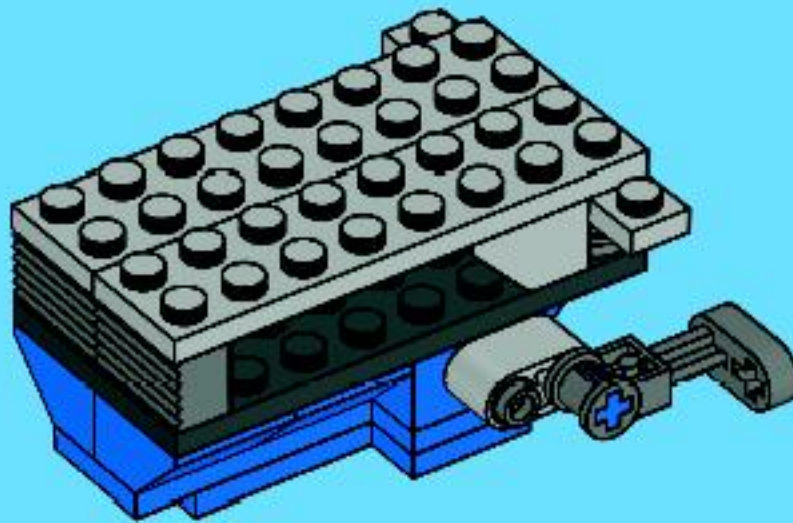



1x

12

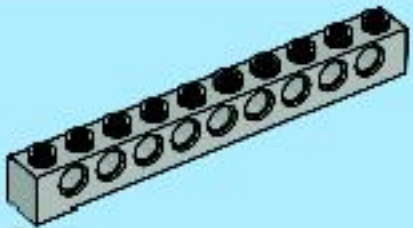
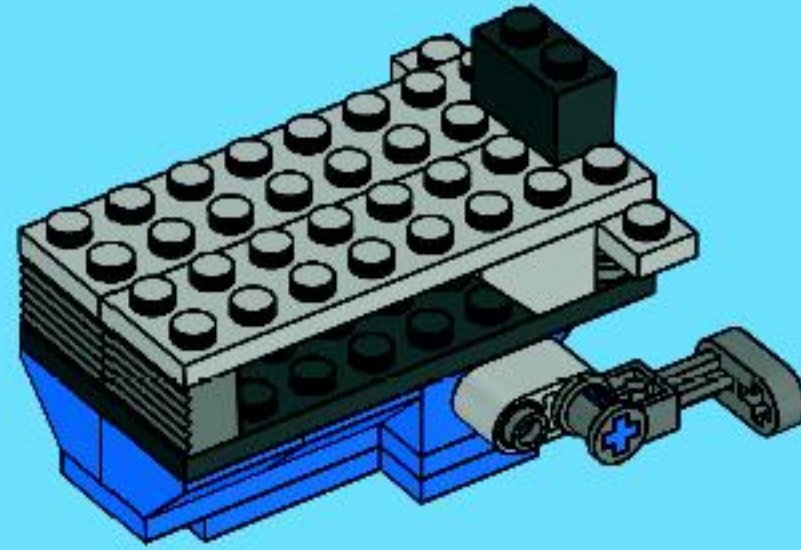

2x

13

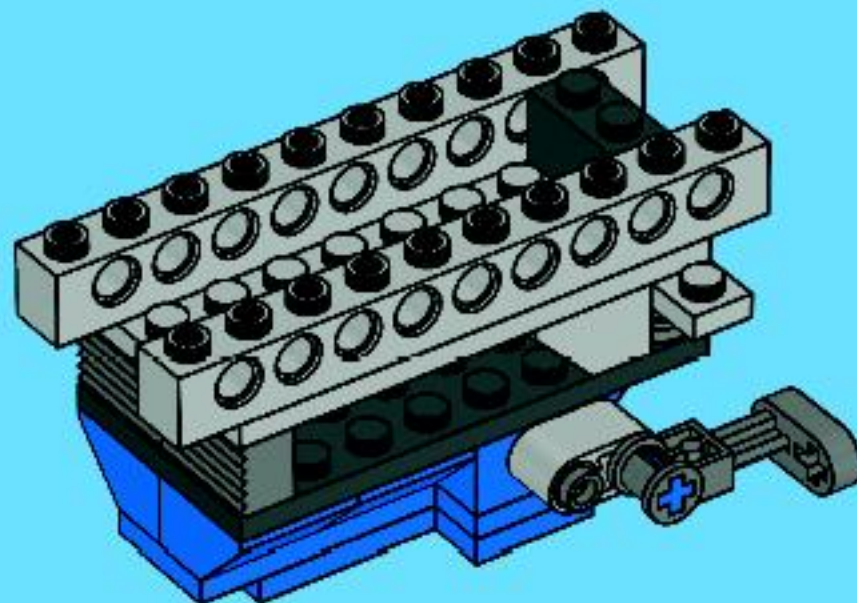



2x

14

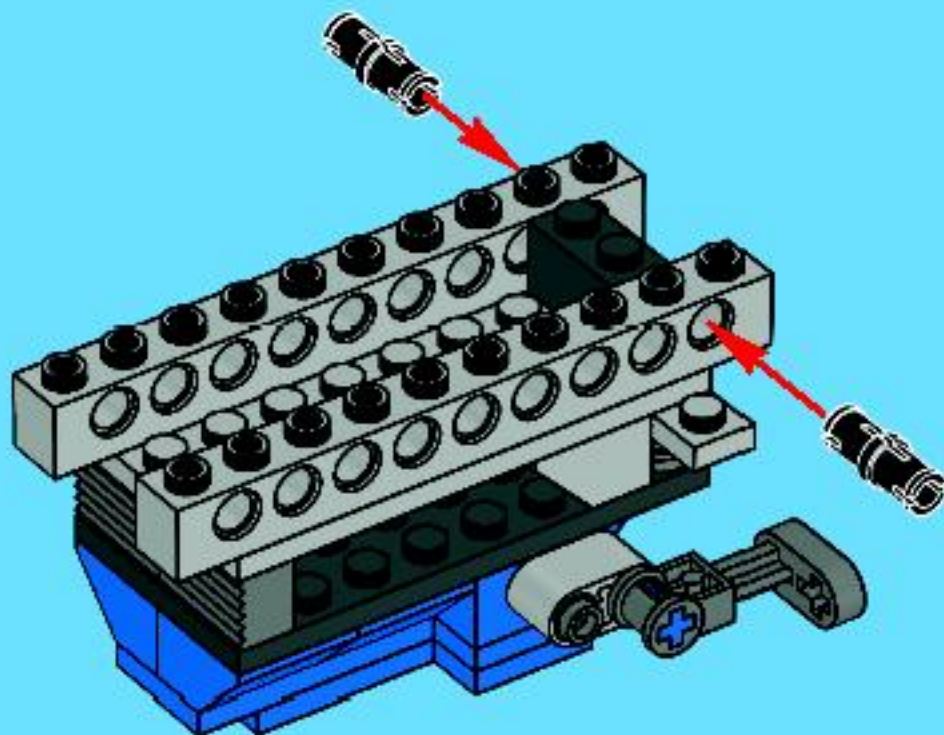

4x



2x

15

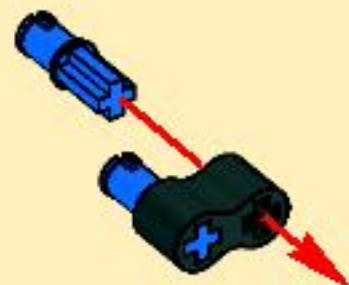
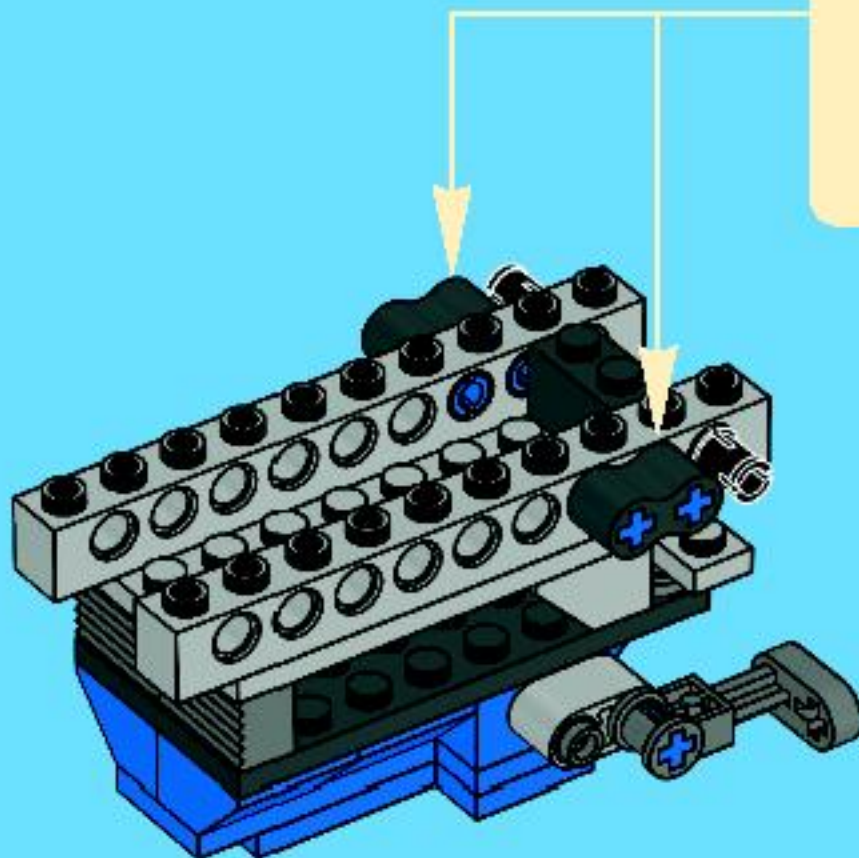

2x



4x

16

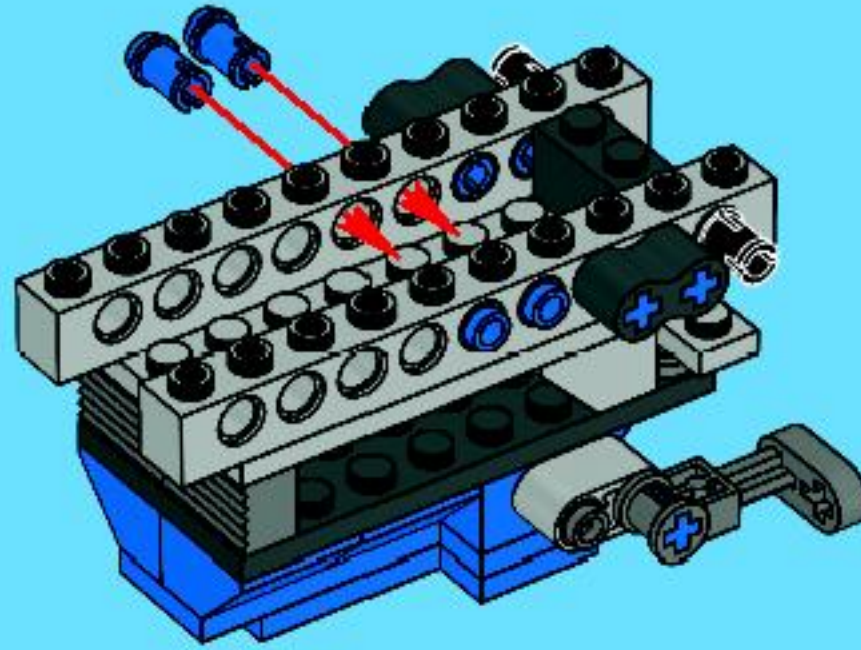

2x



2x



2x

17

1



2



2x

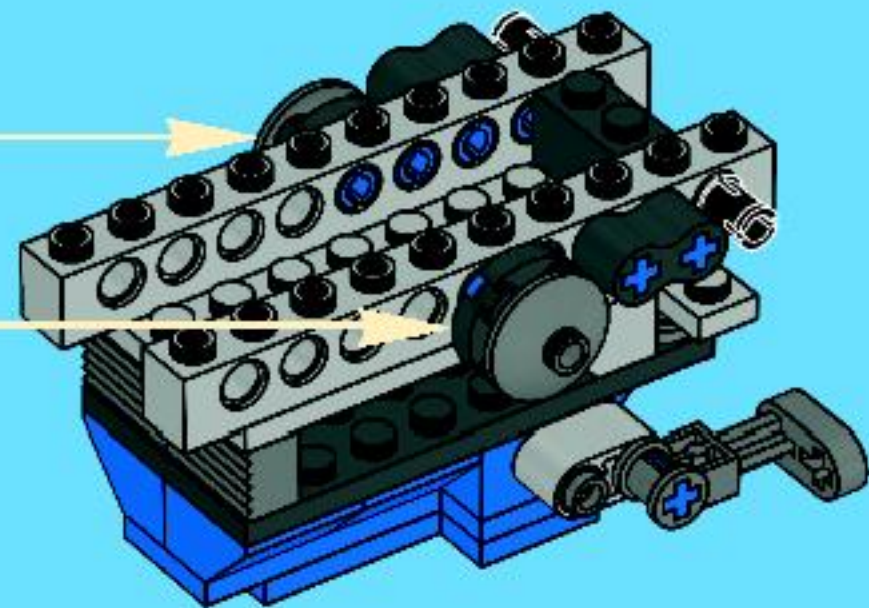

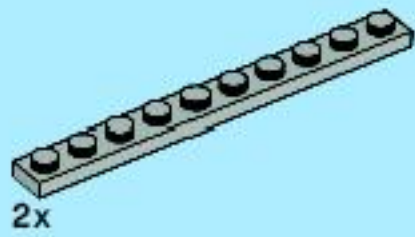

18

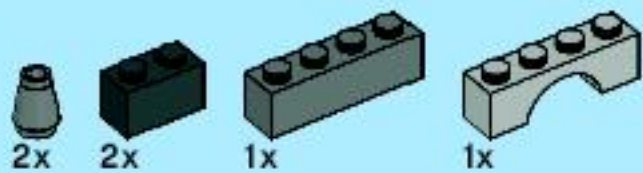
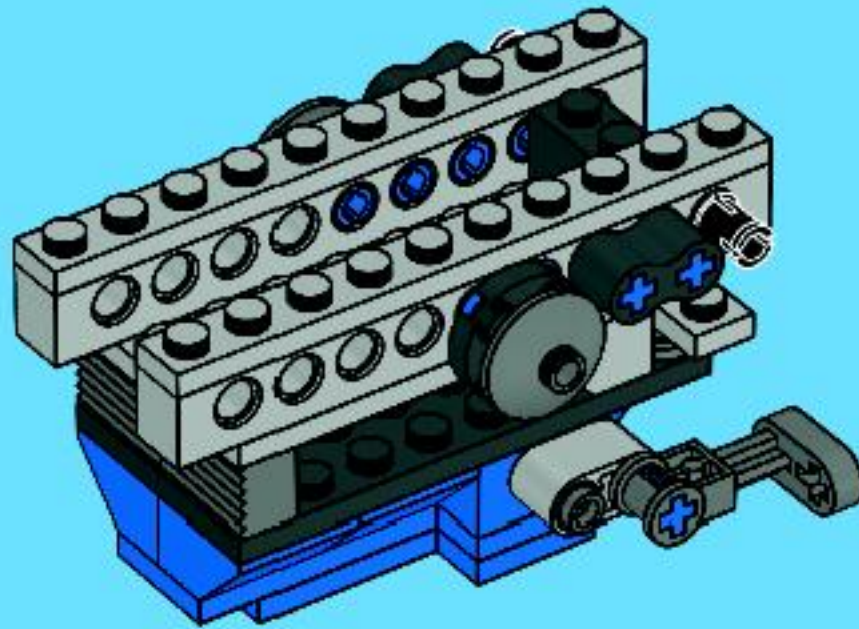

19

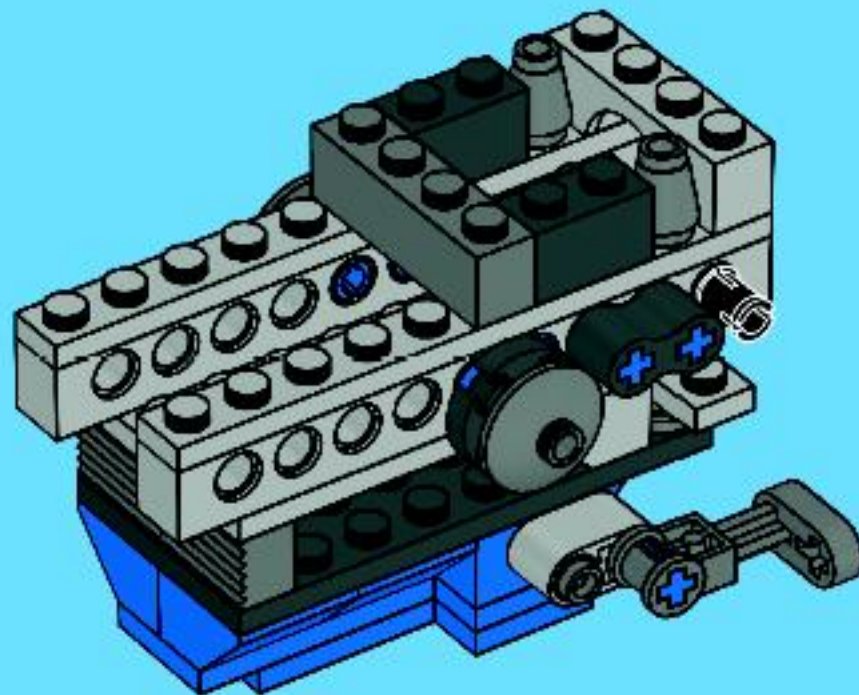



20

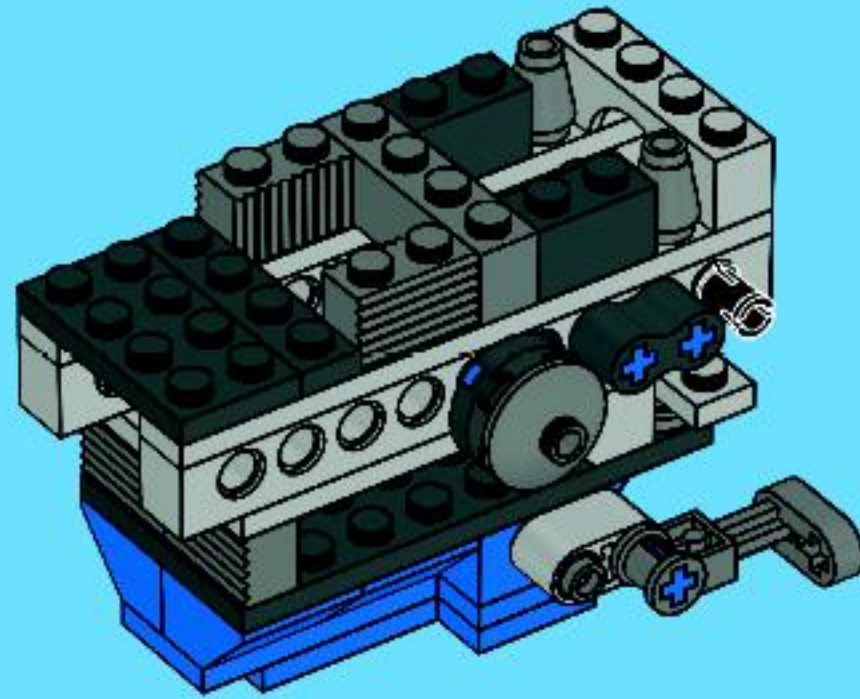

21

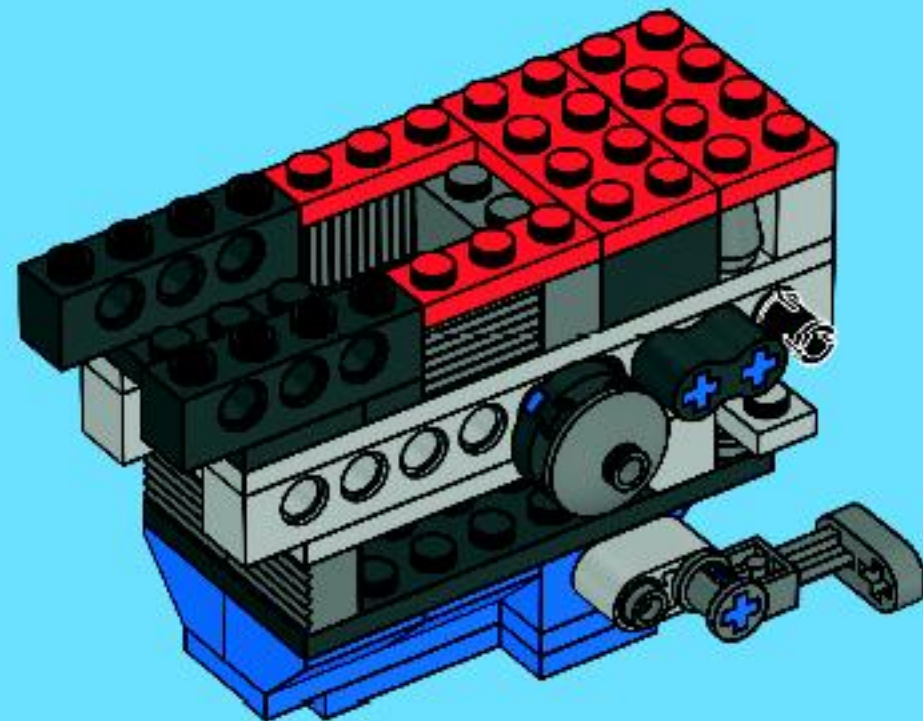



1x

22

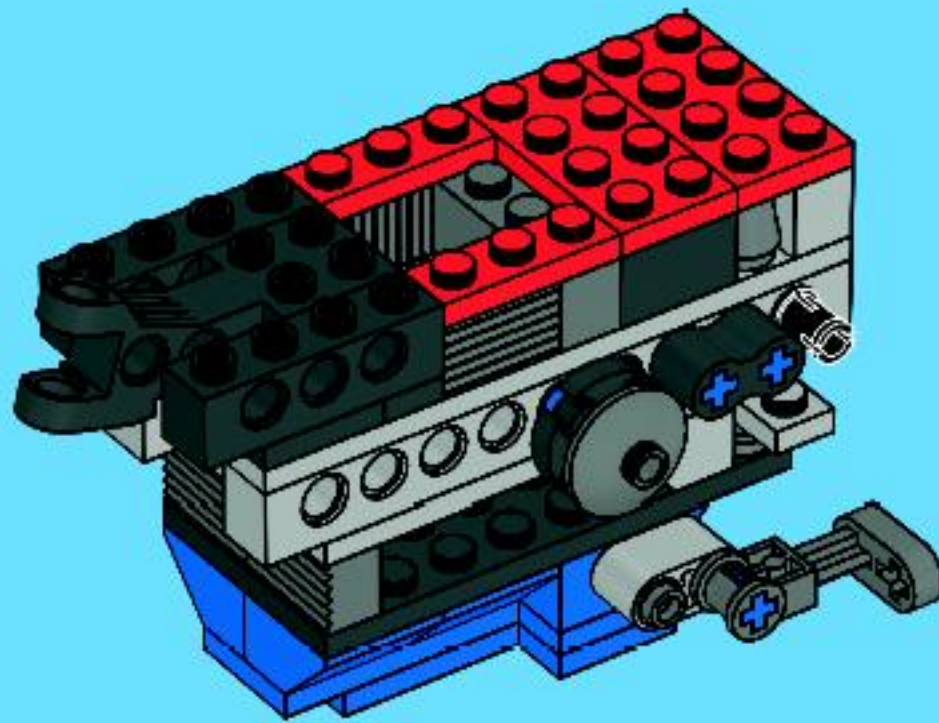



2x

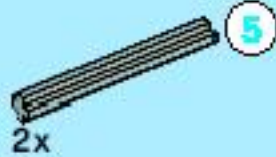

2x



1:1

23

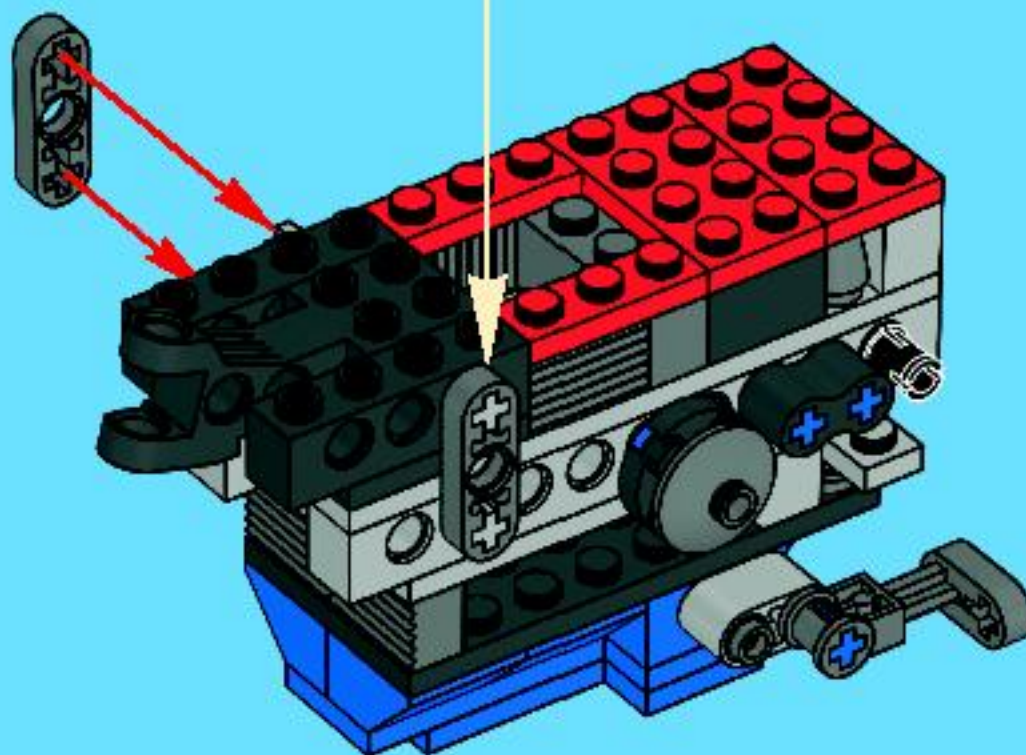
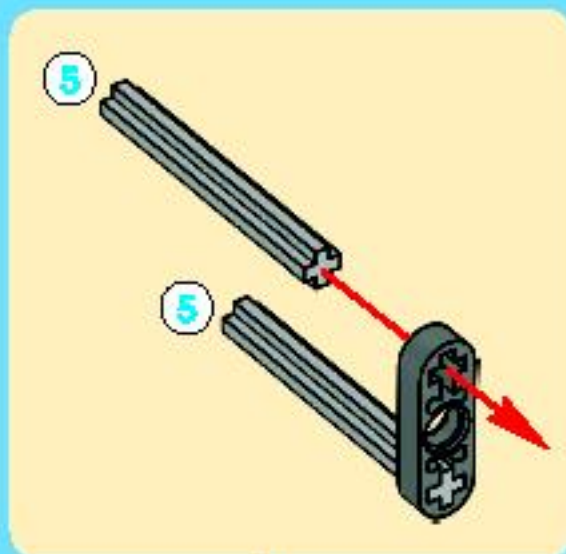



24

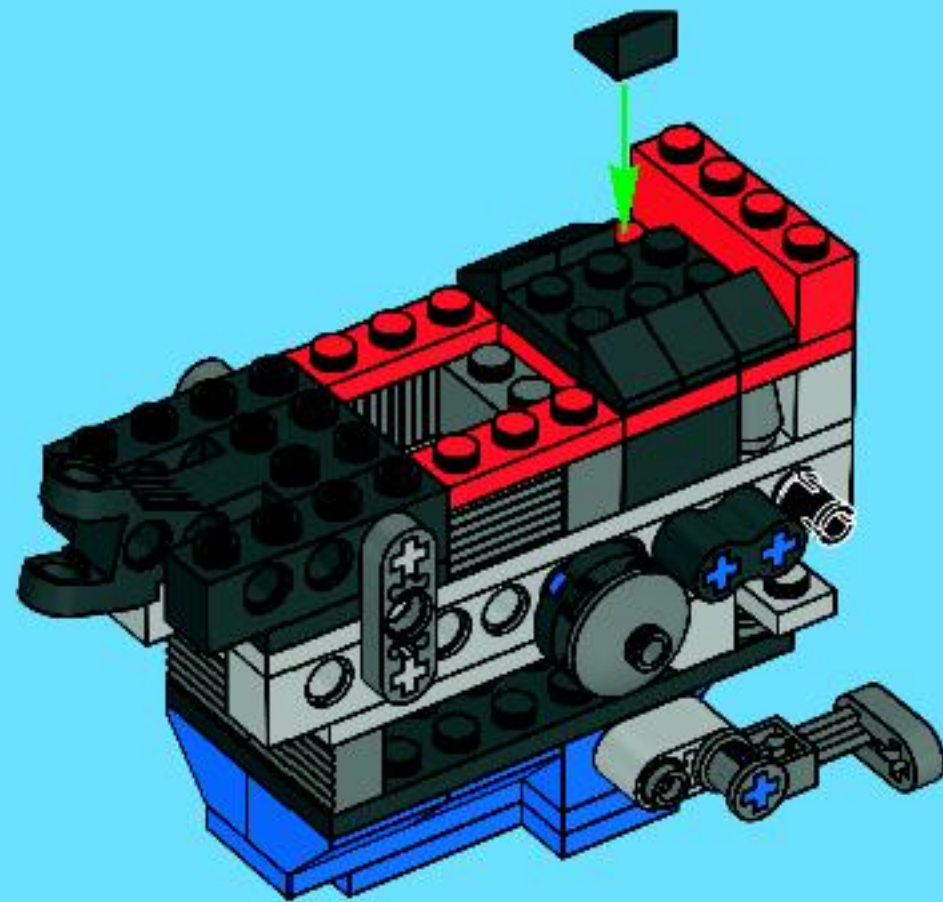

25

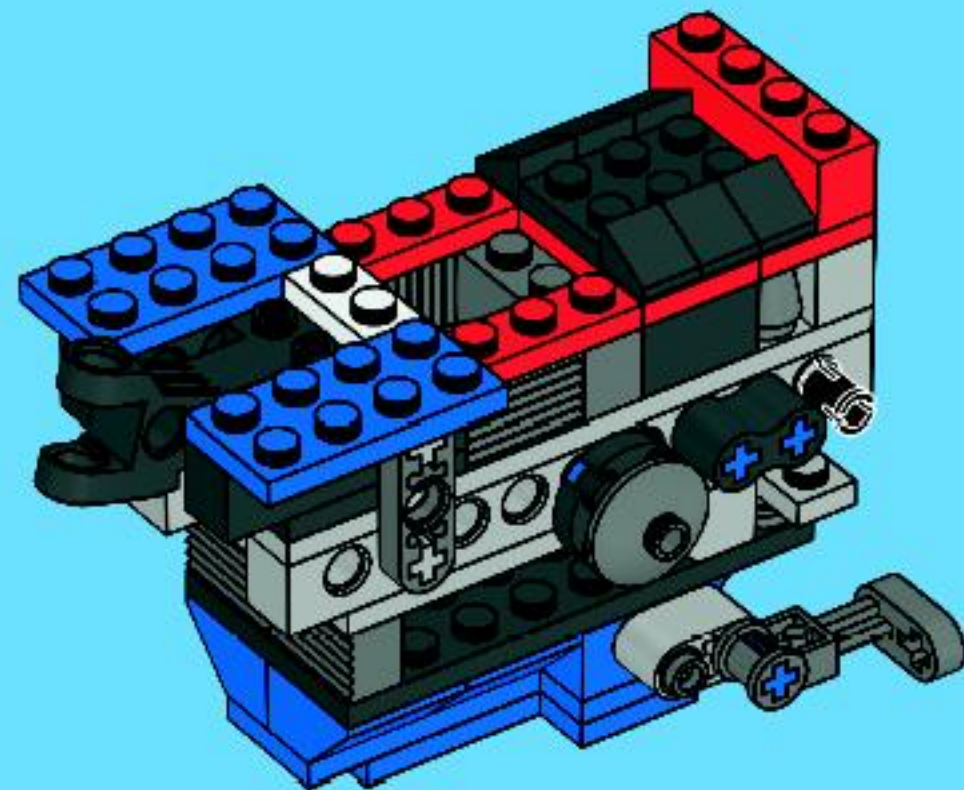



1x



1x

26

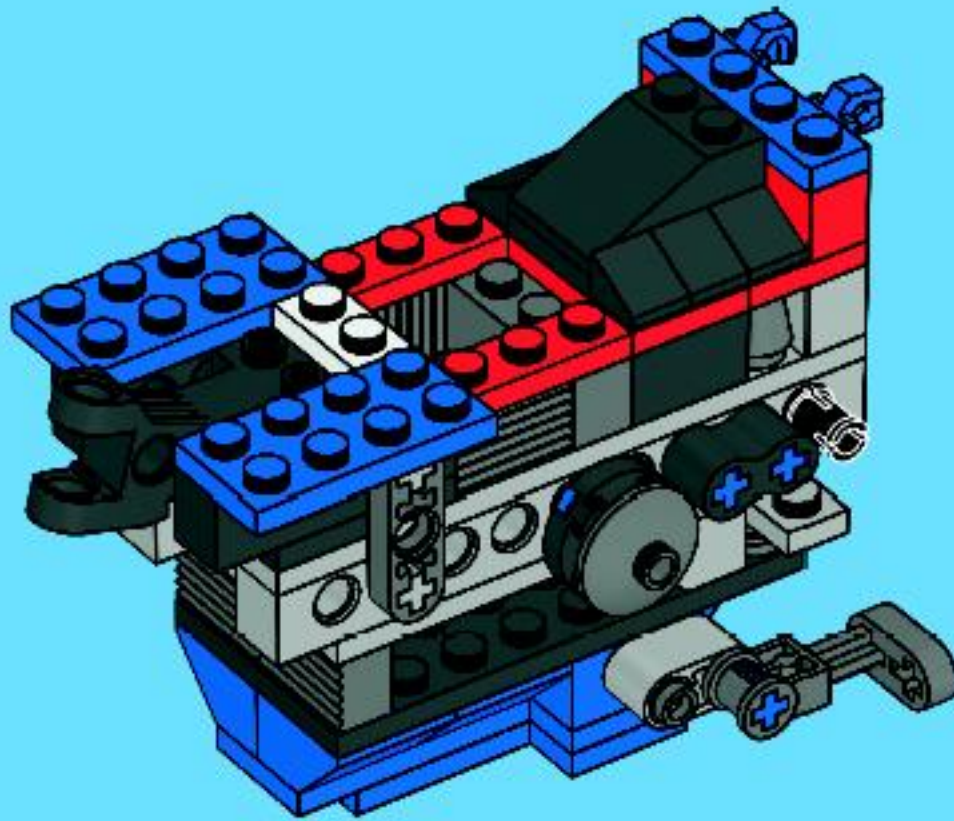



1x



1x



1x

27

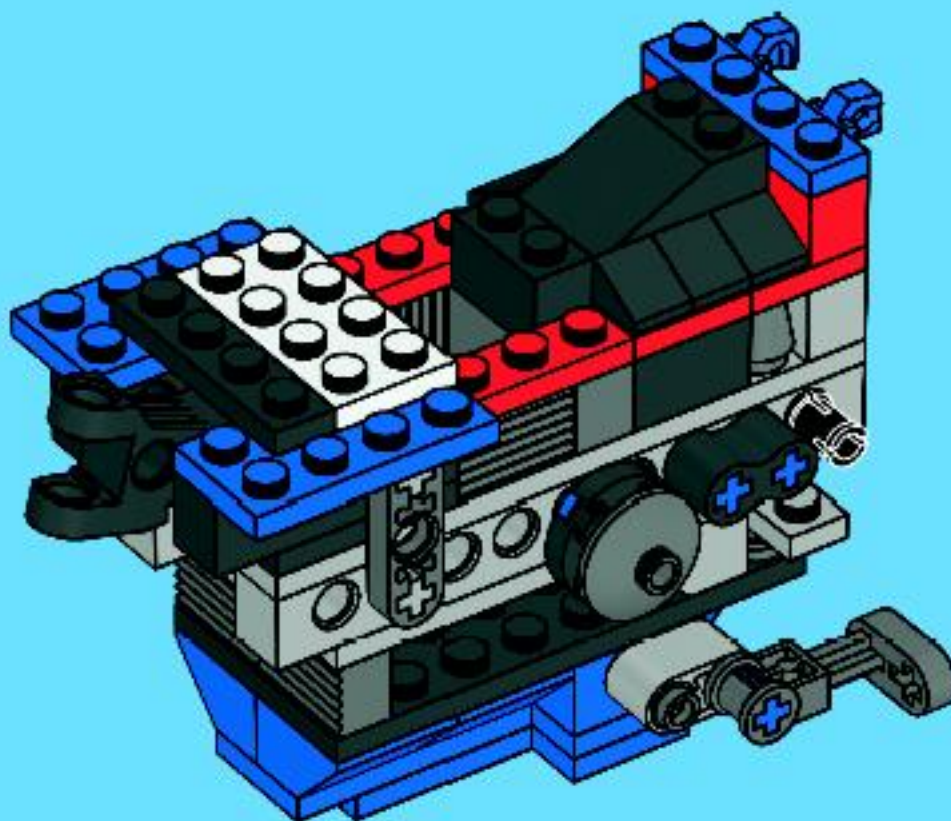

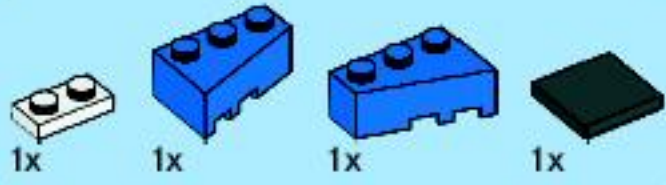

28

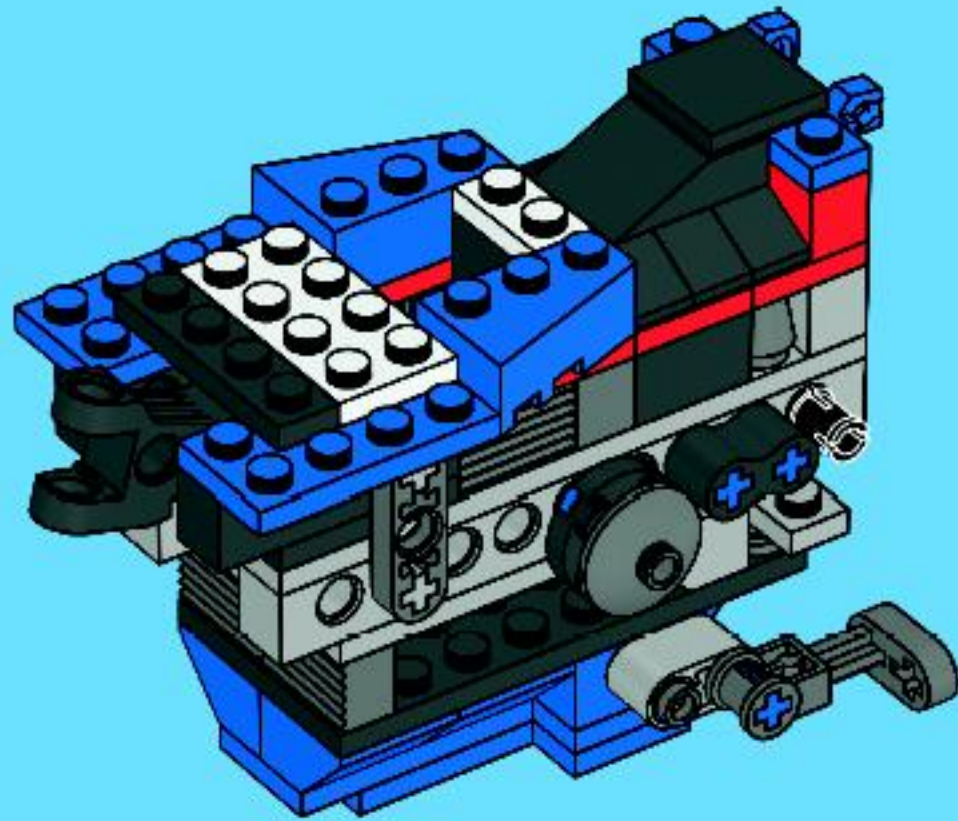

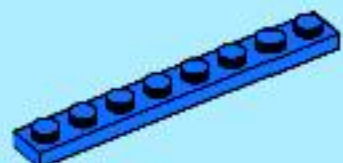

2x

29

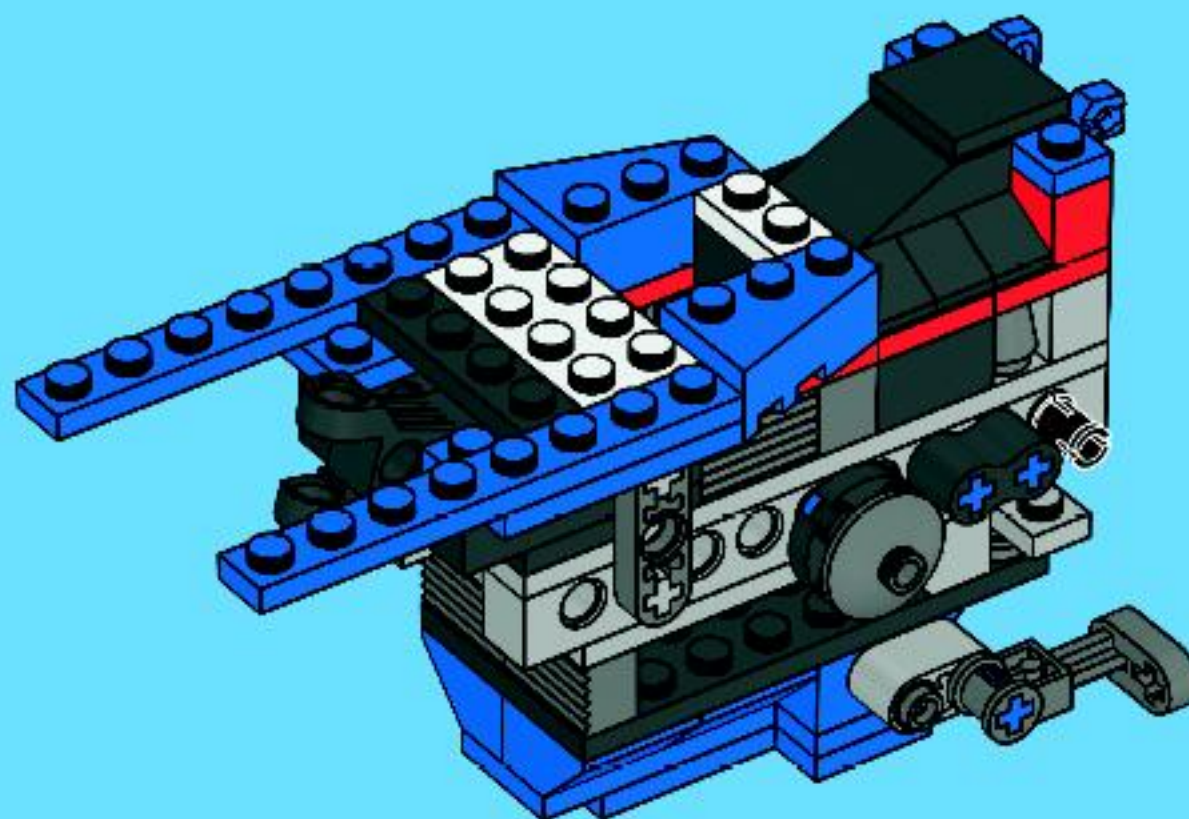



1x



2x



2x

30

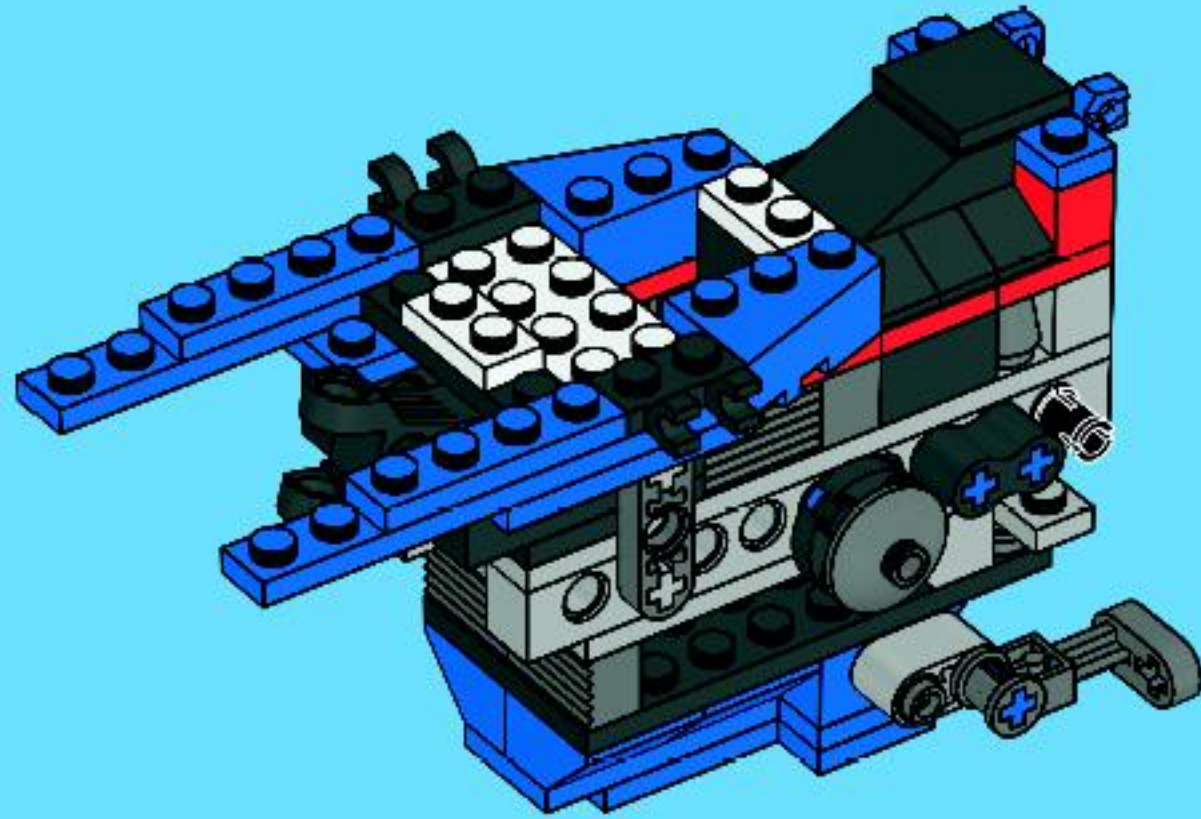



31

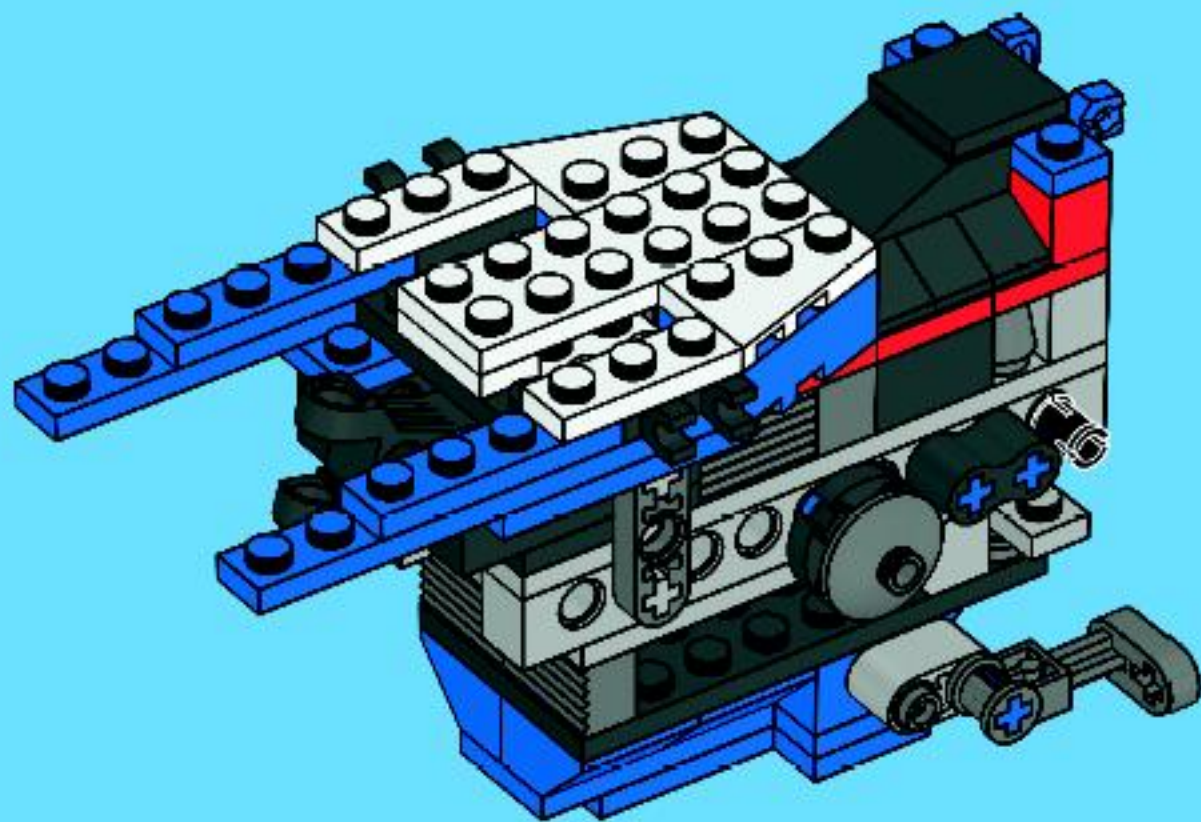



1x

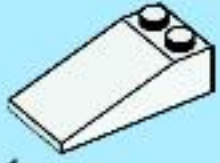

1x



1x

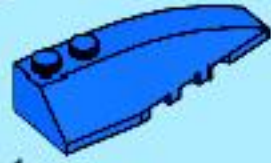

1x

32

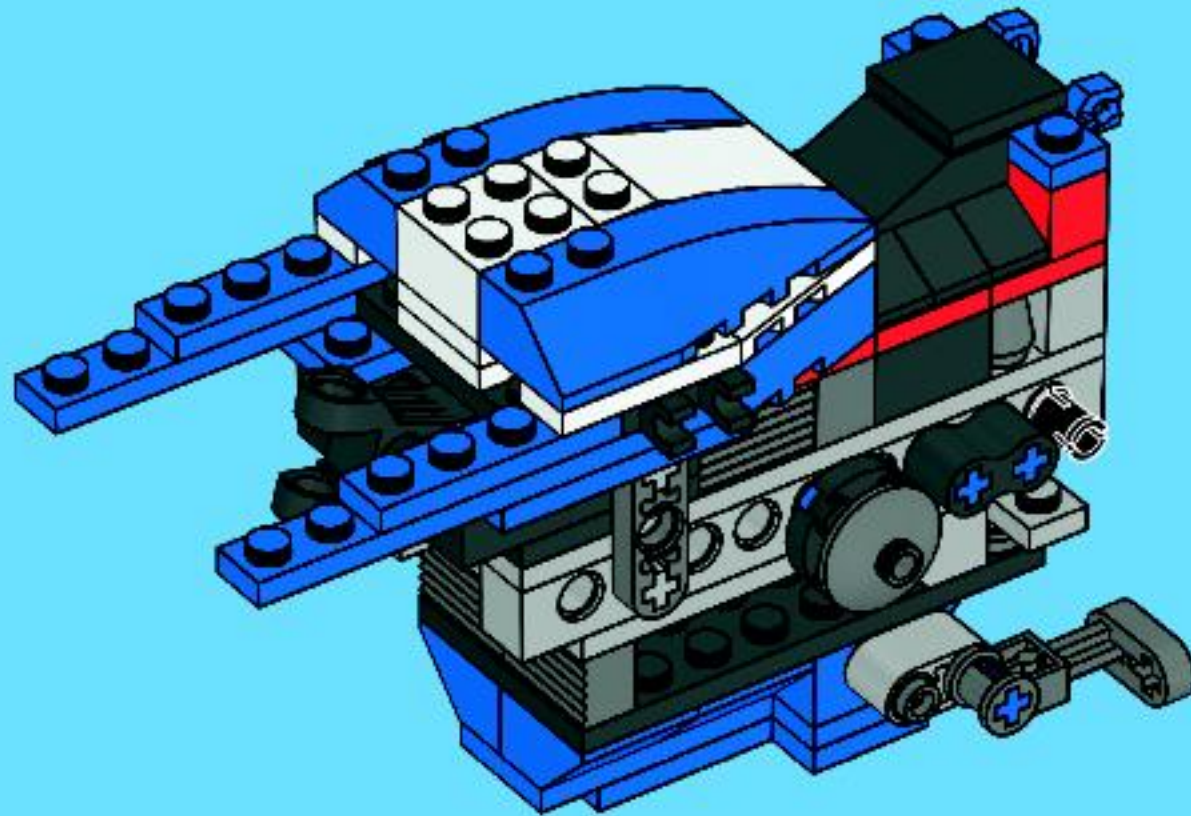



2x



2x



1x

33

1

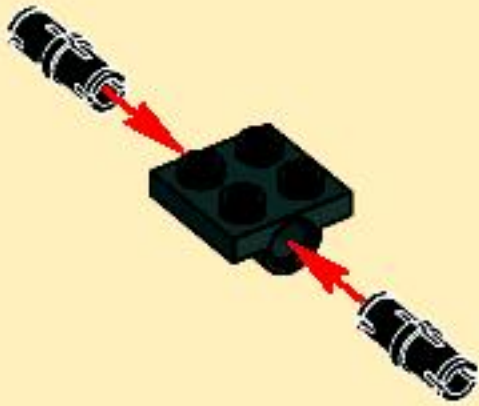

2

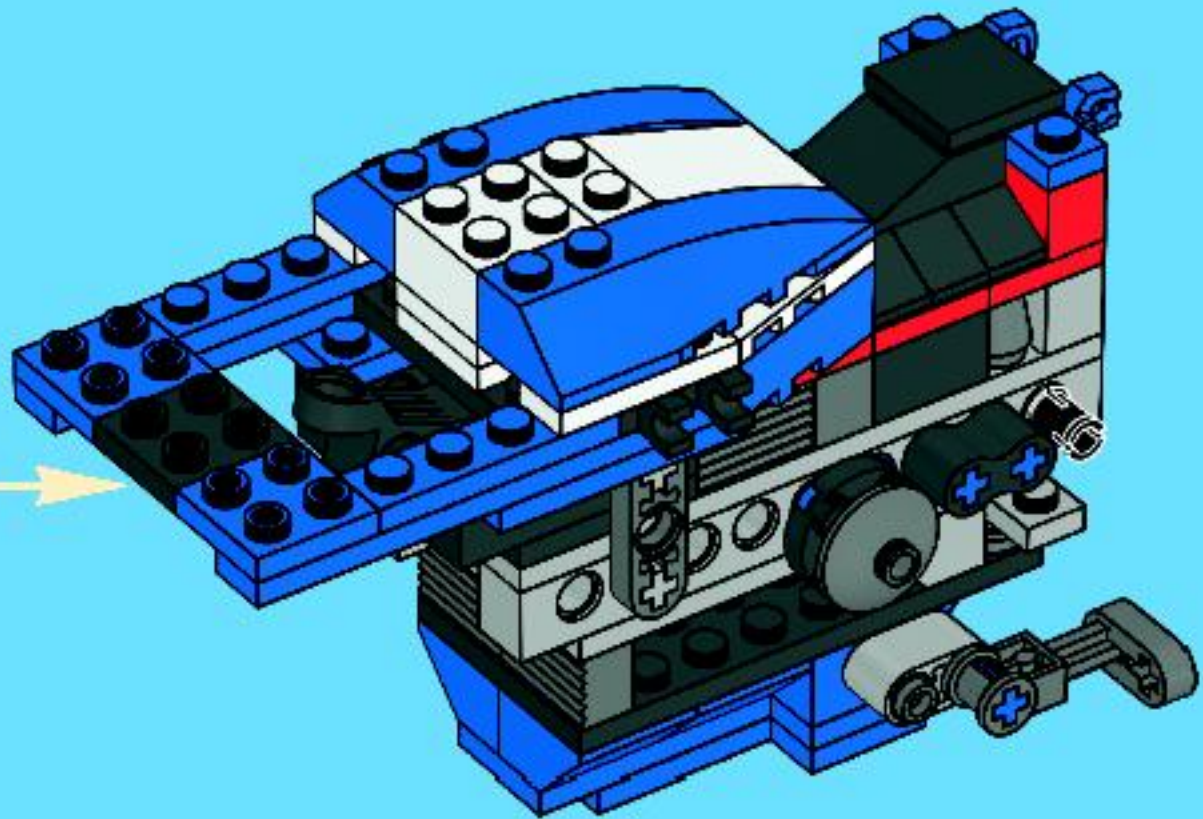
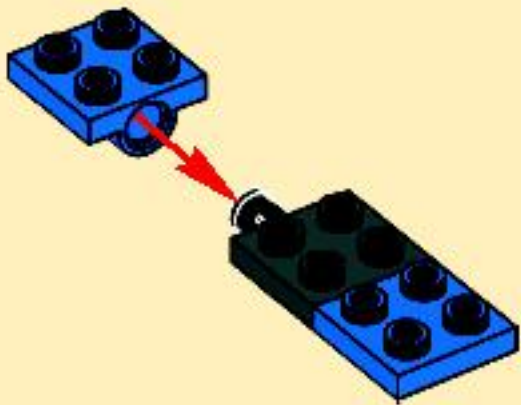



2x



2x

34

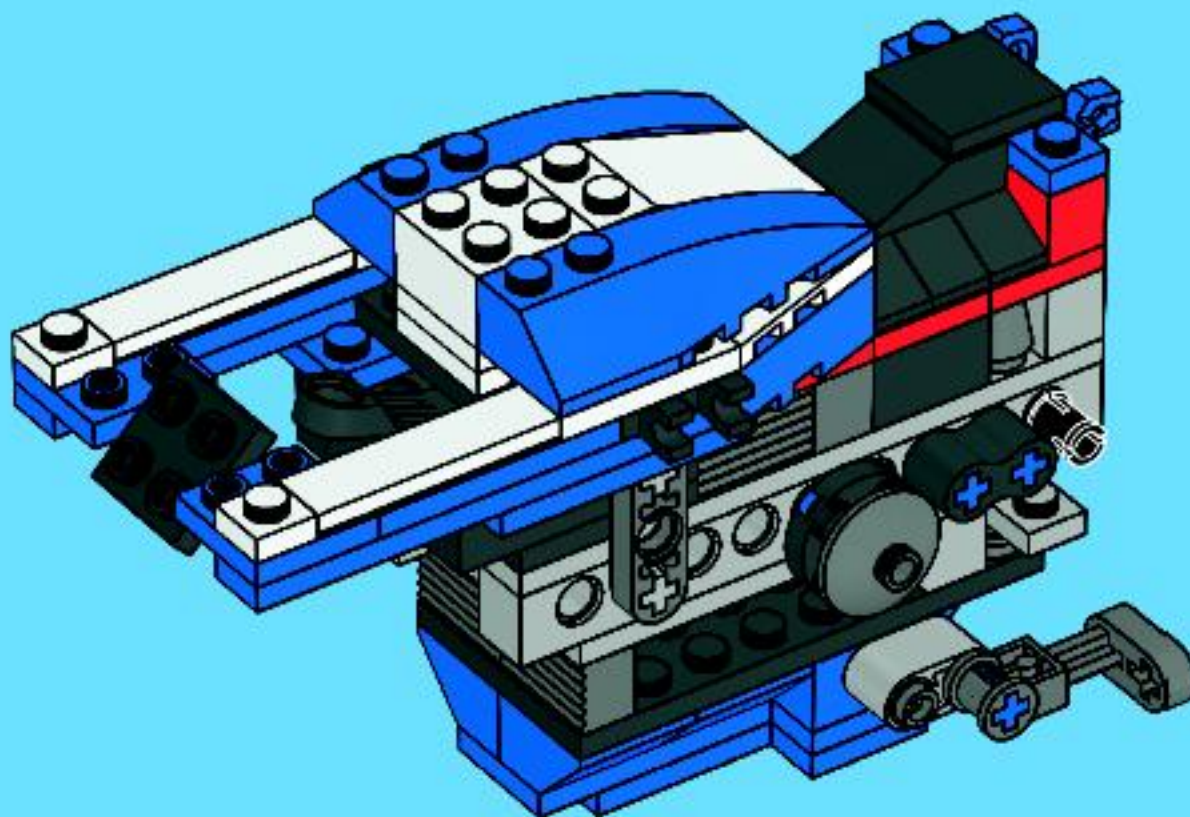

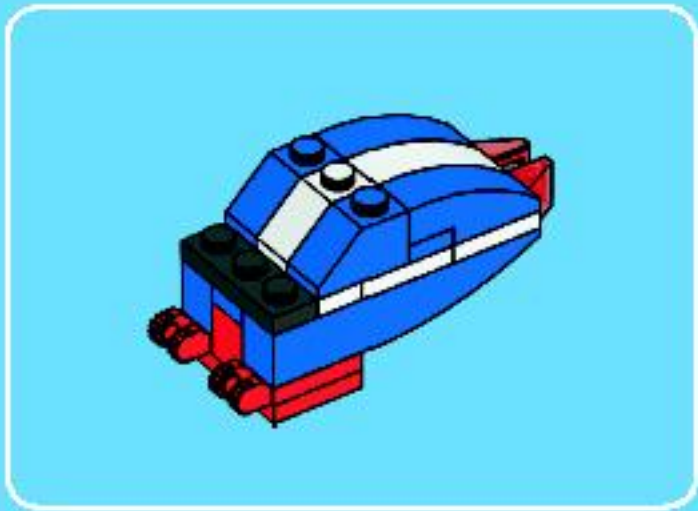

1



2

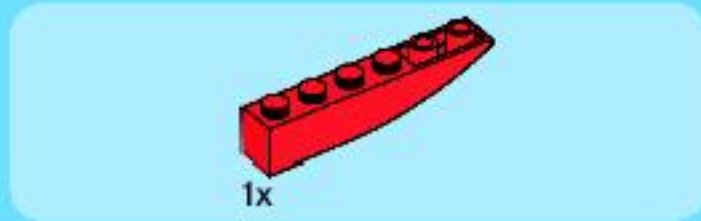

3

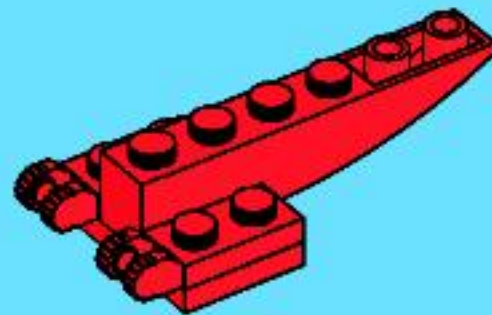

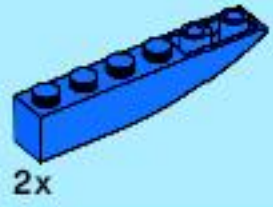

4

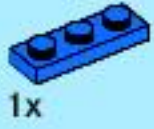
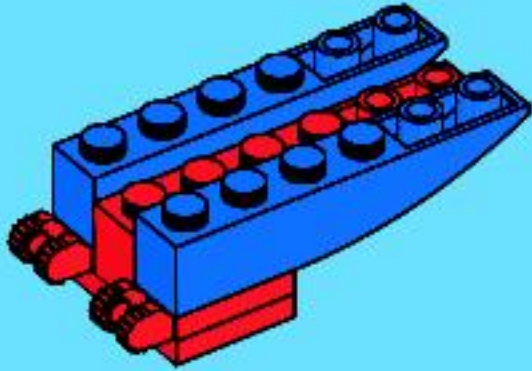

5

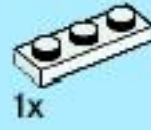
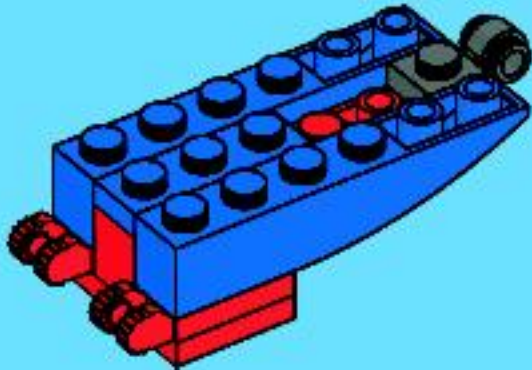

6

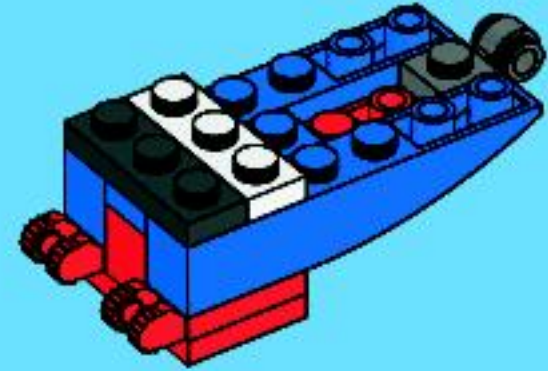

7

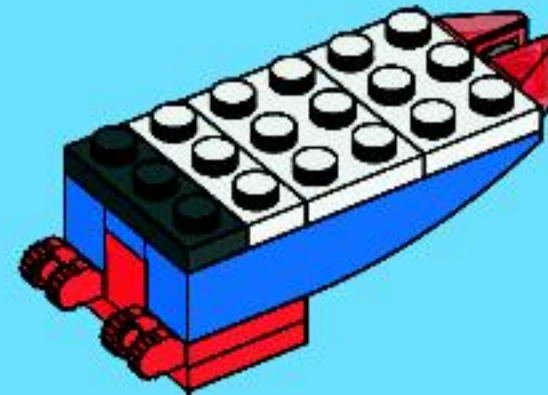



1x



1x

10

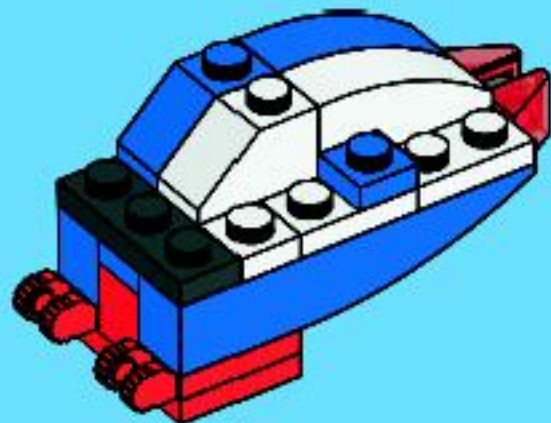

1x



1x

11

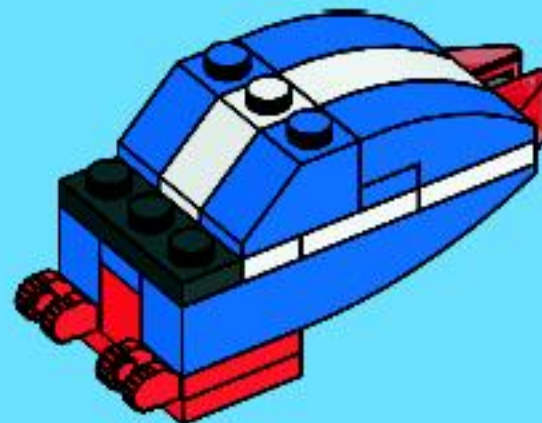

35

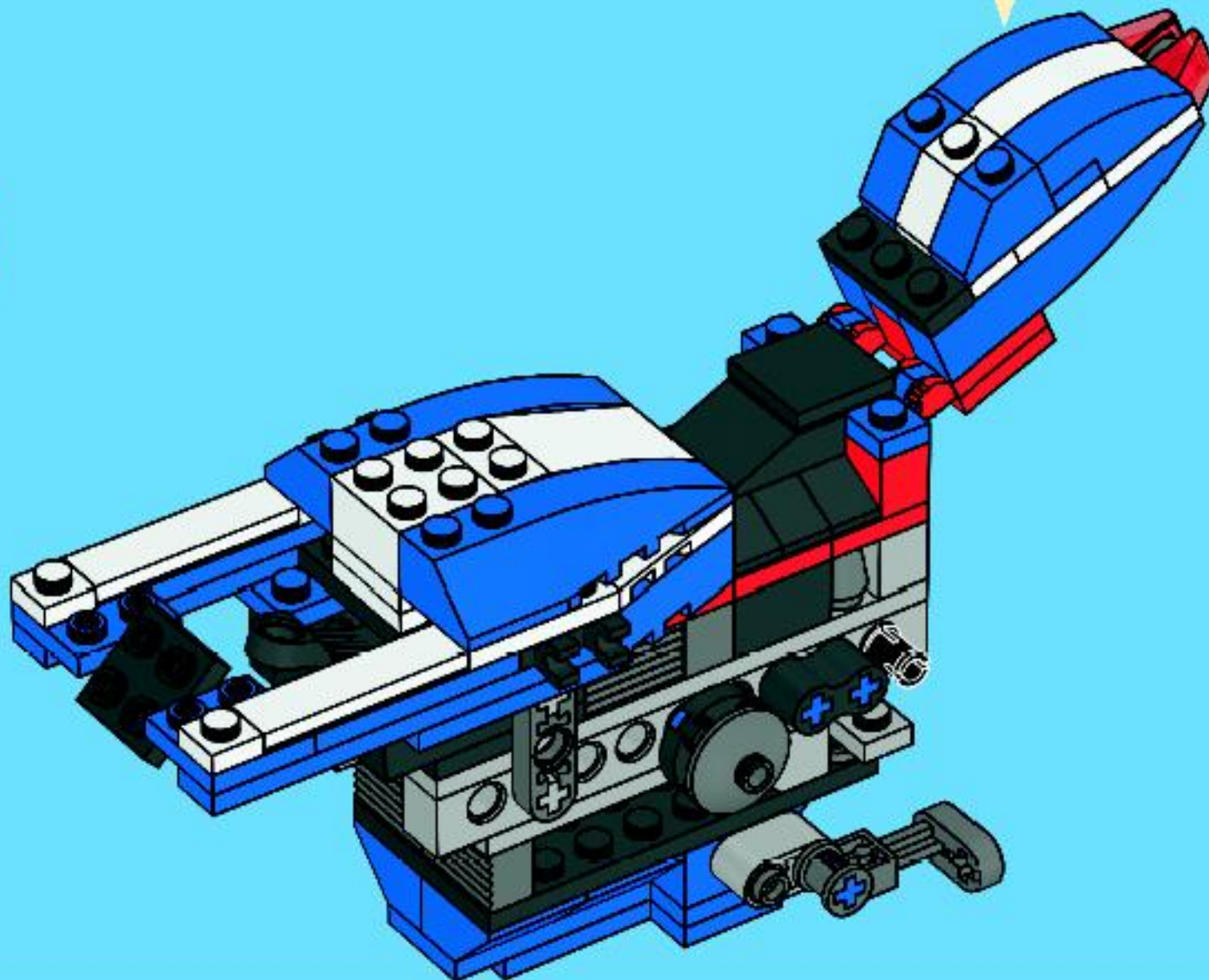



1x

36

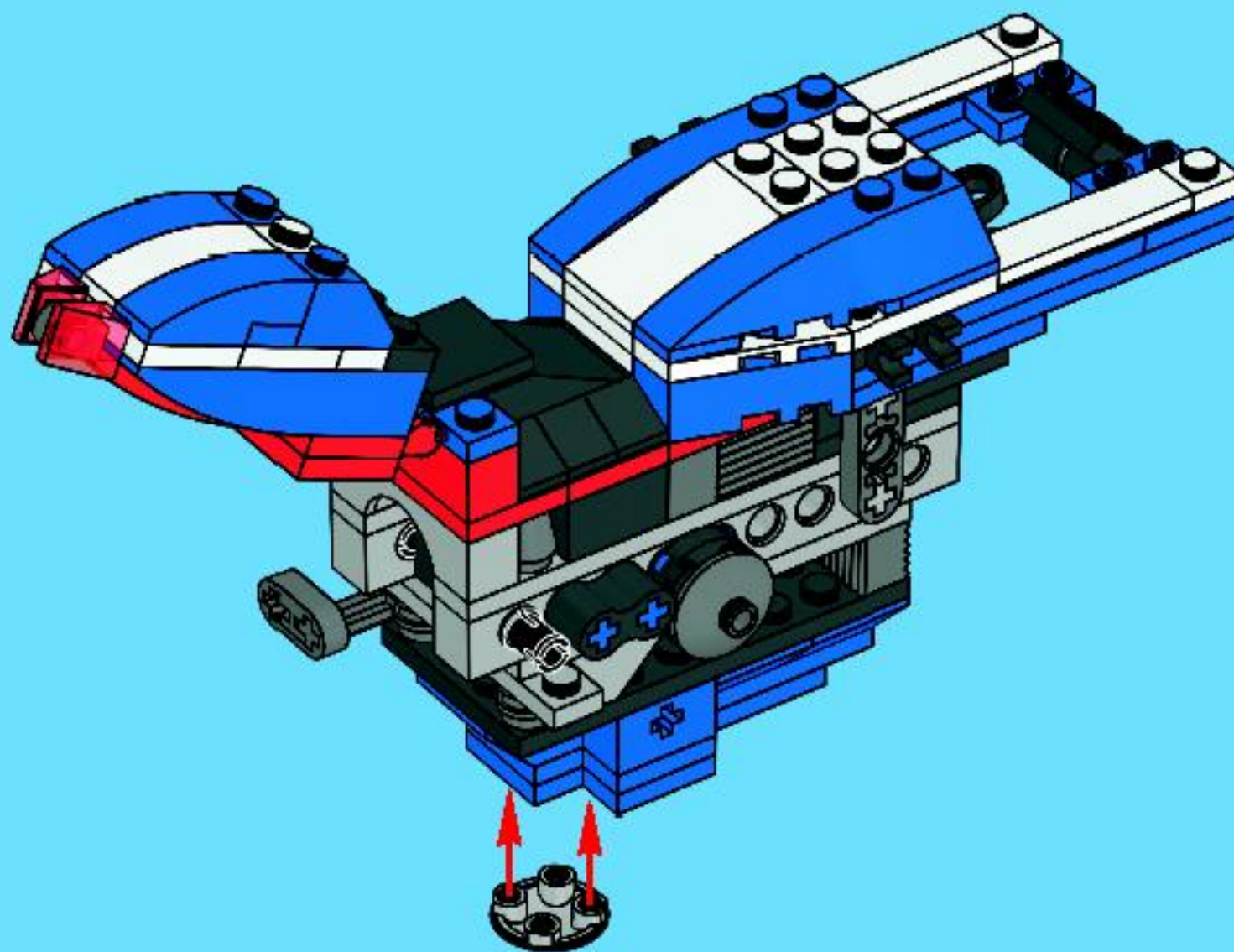

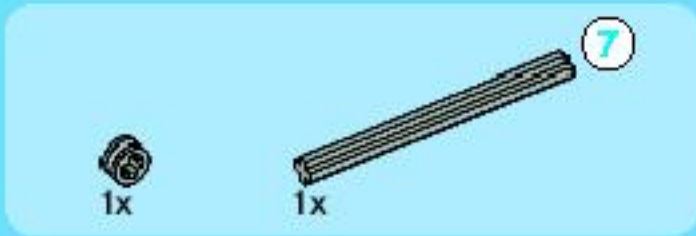
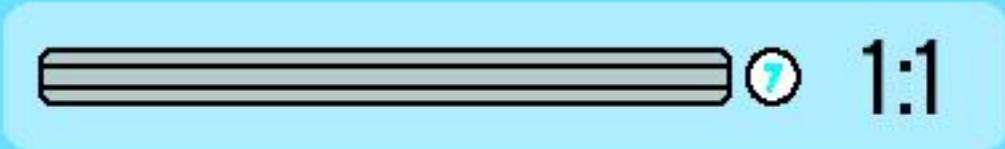
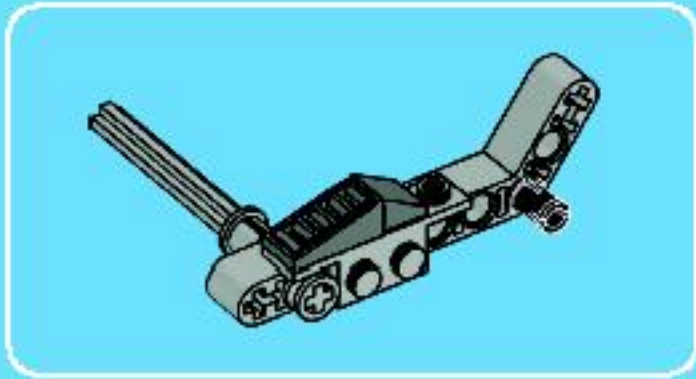

1

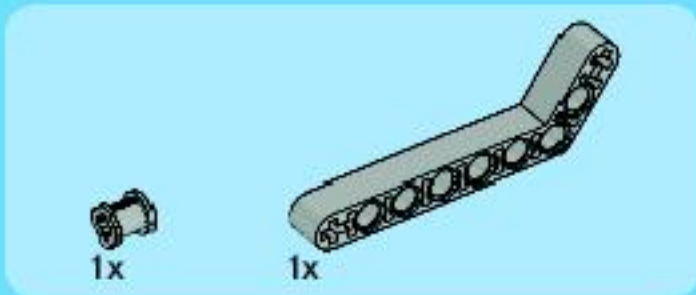
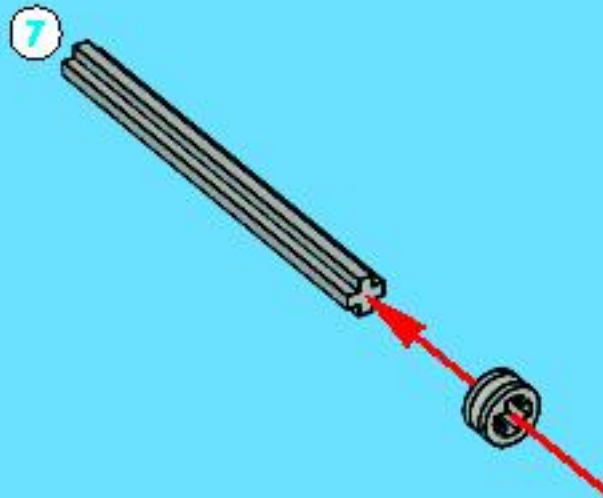

2

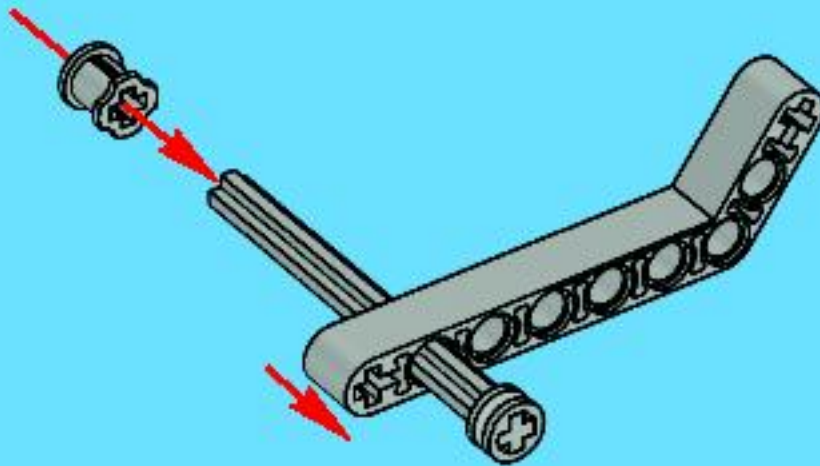



2x



1x

3

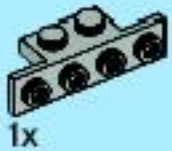
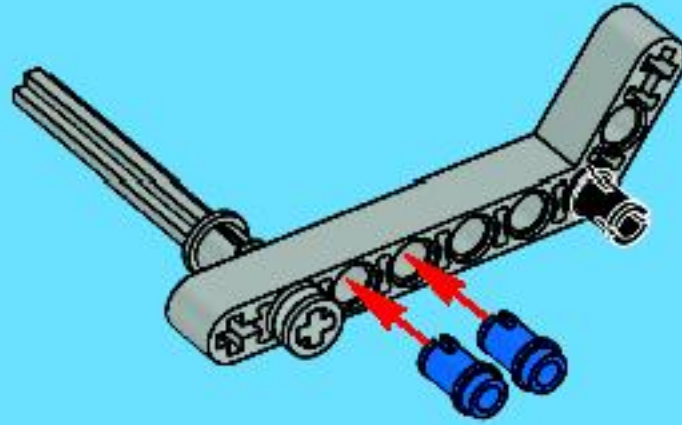

1x

4

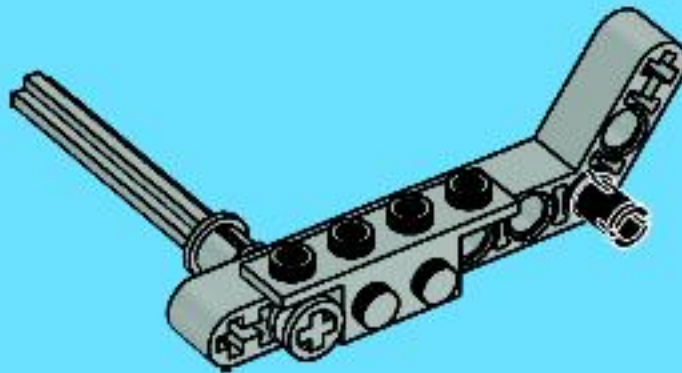



1x



1x

5

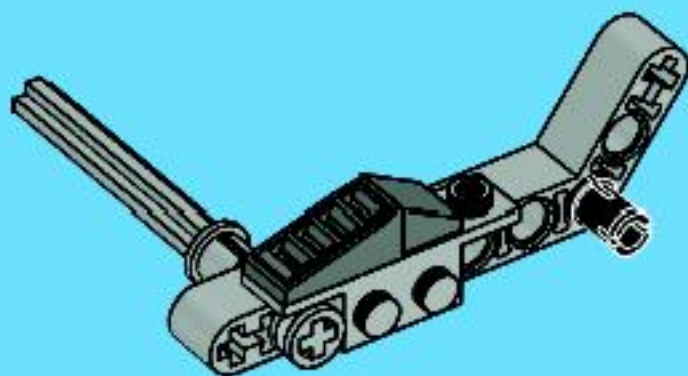

37

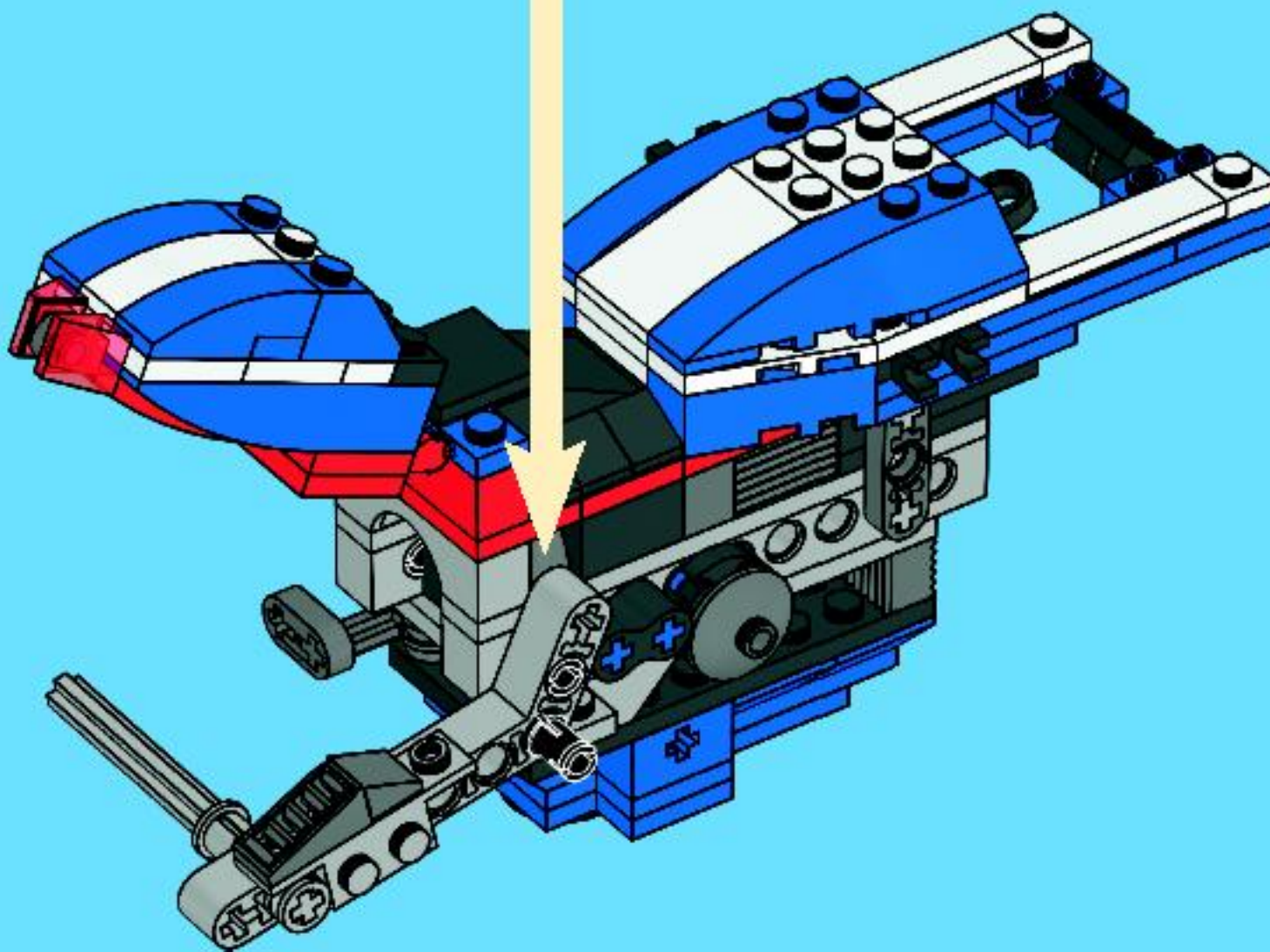



38

1

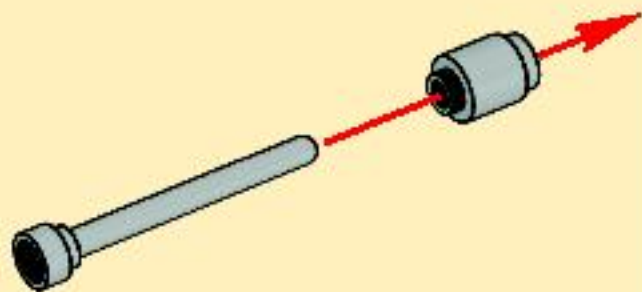

2

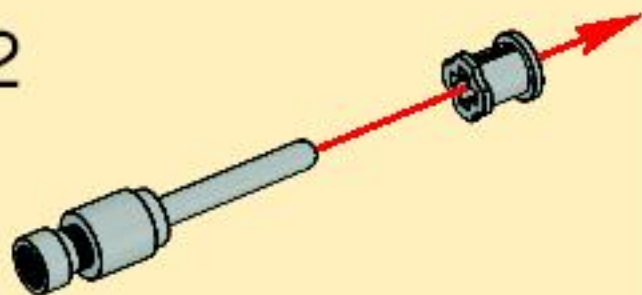

3

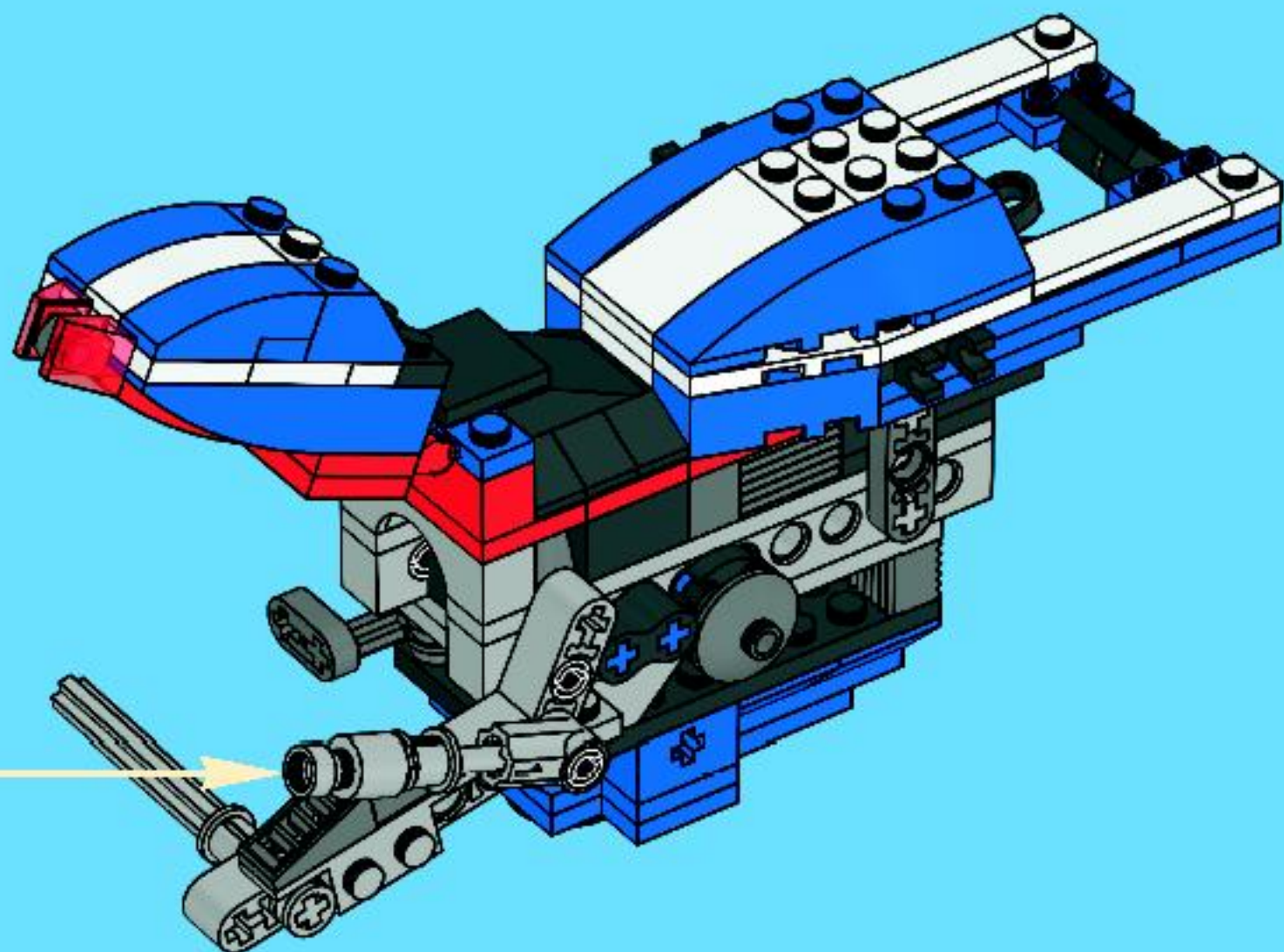
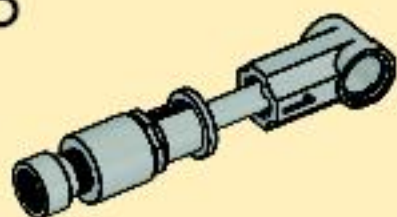

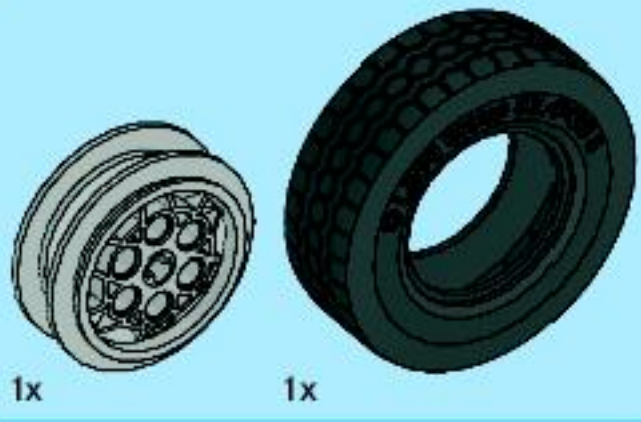

39

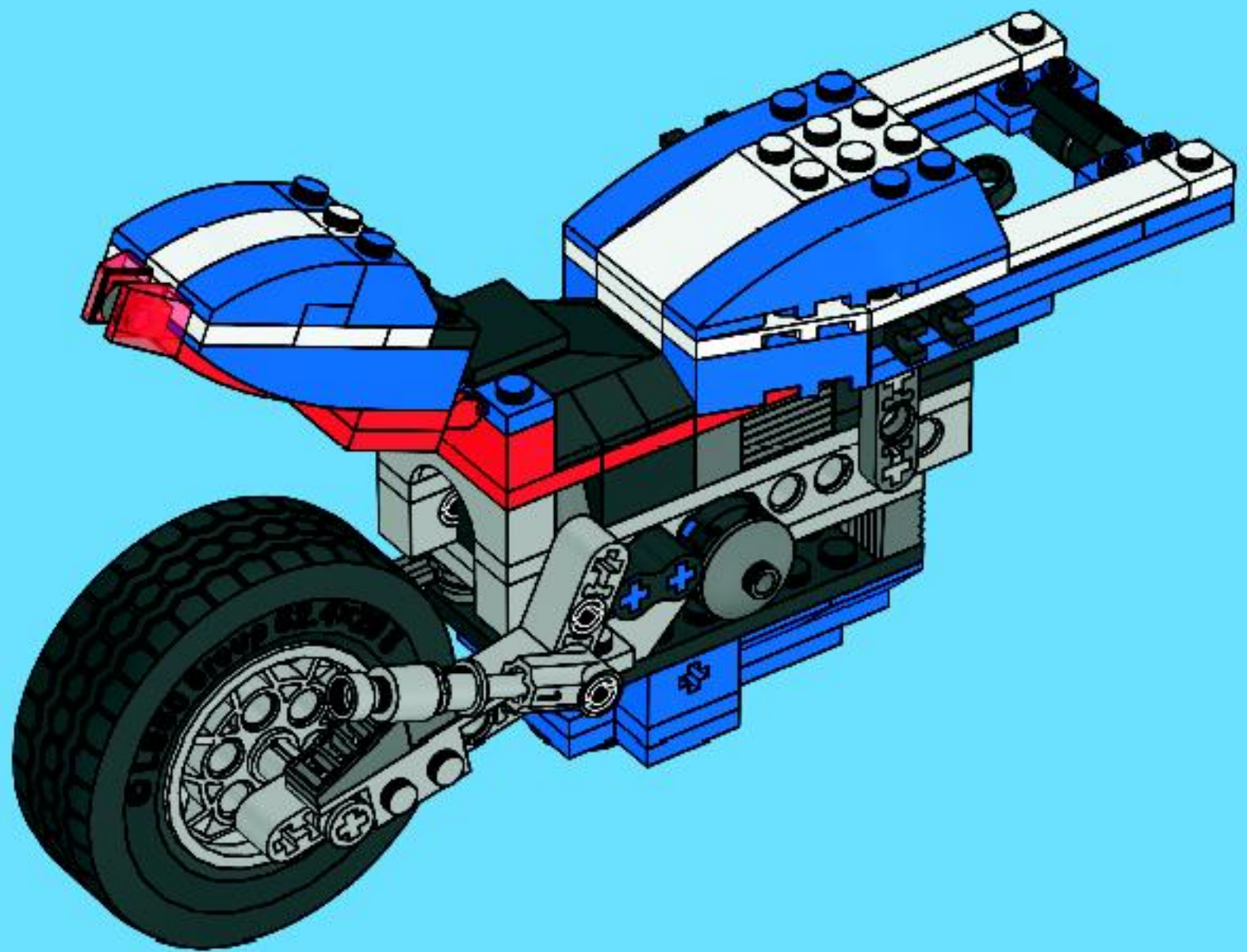



1x



1x

40

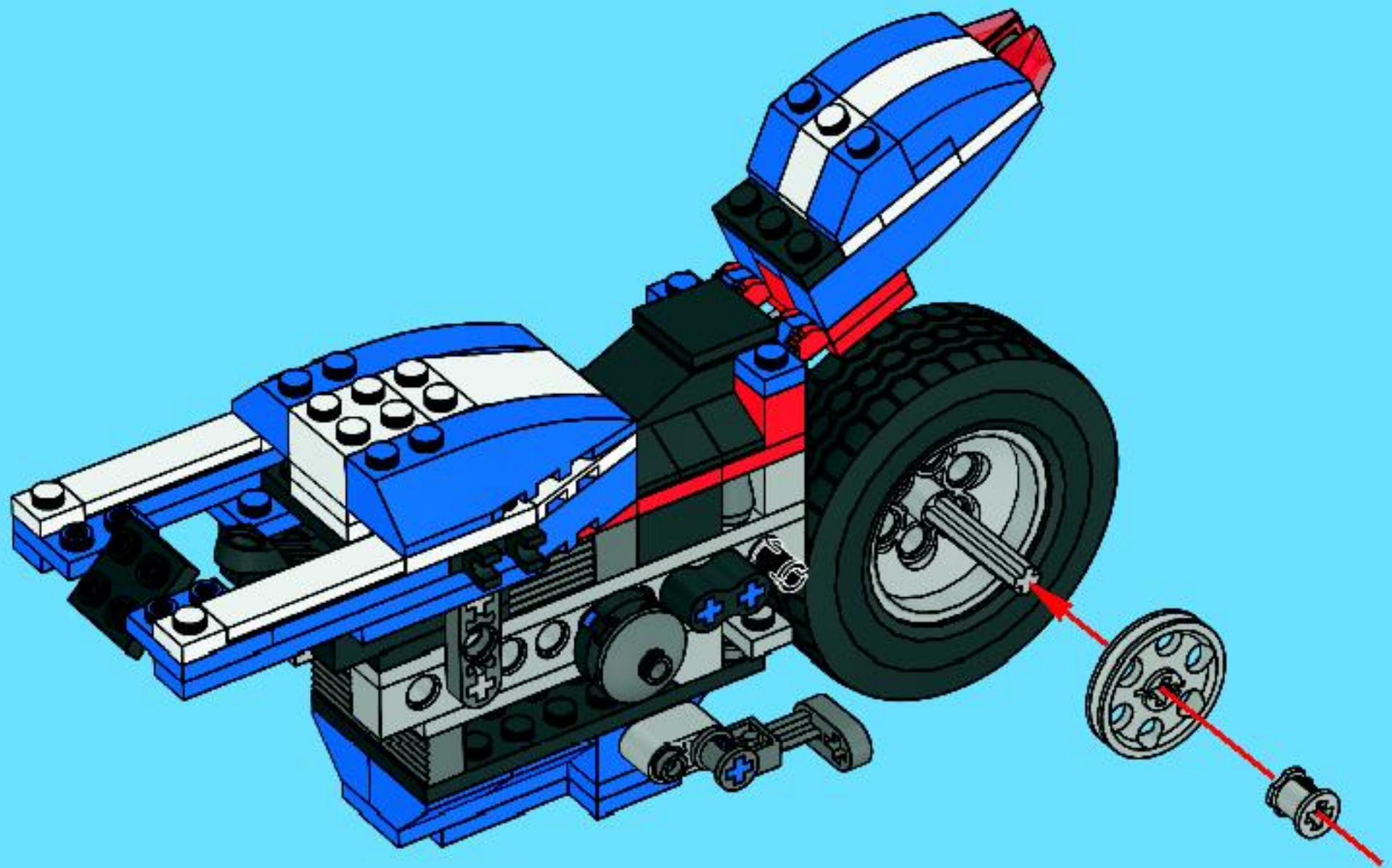

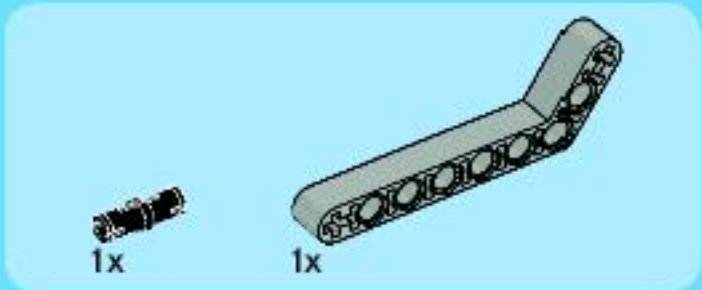
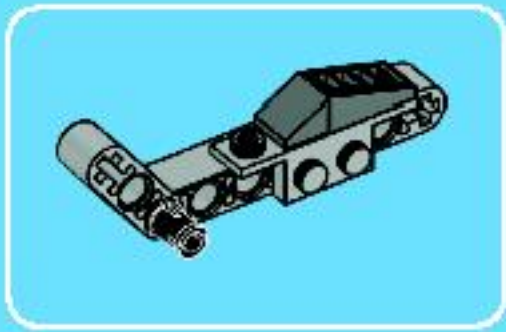

1

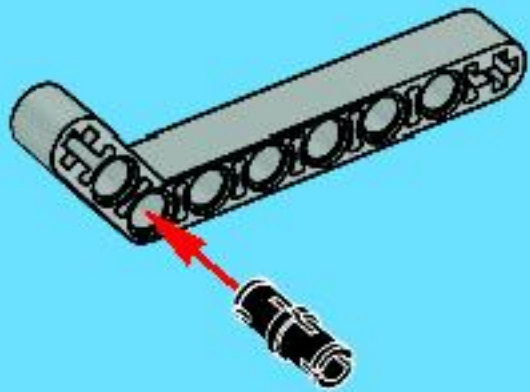

2

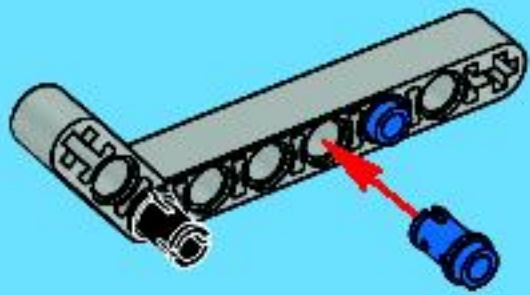

3

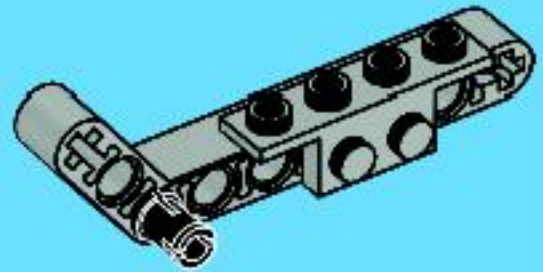

4

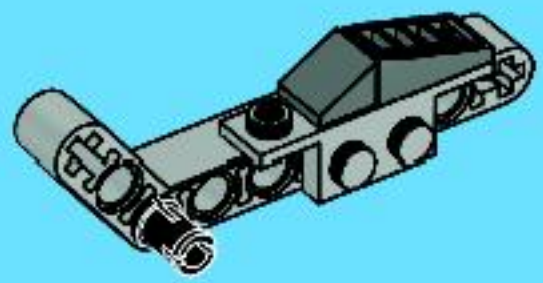

41

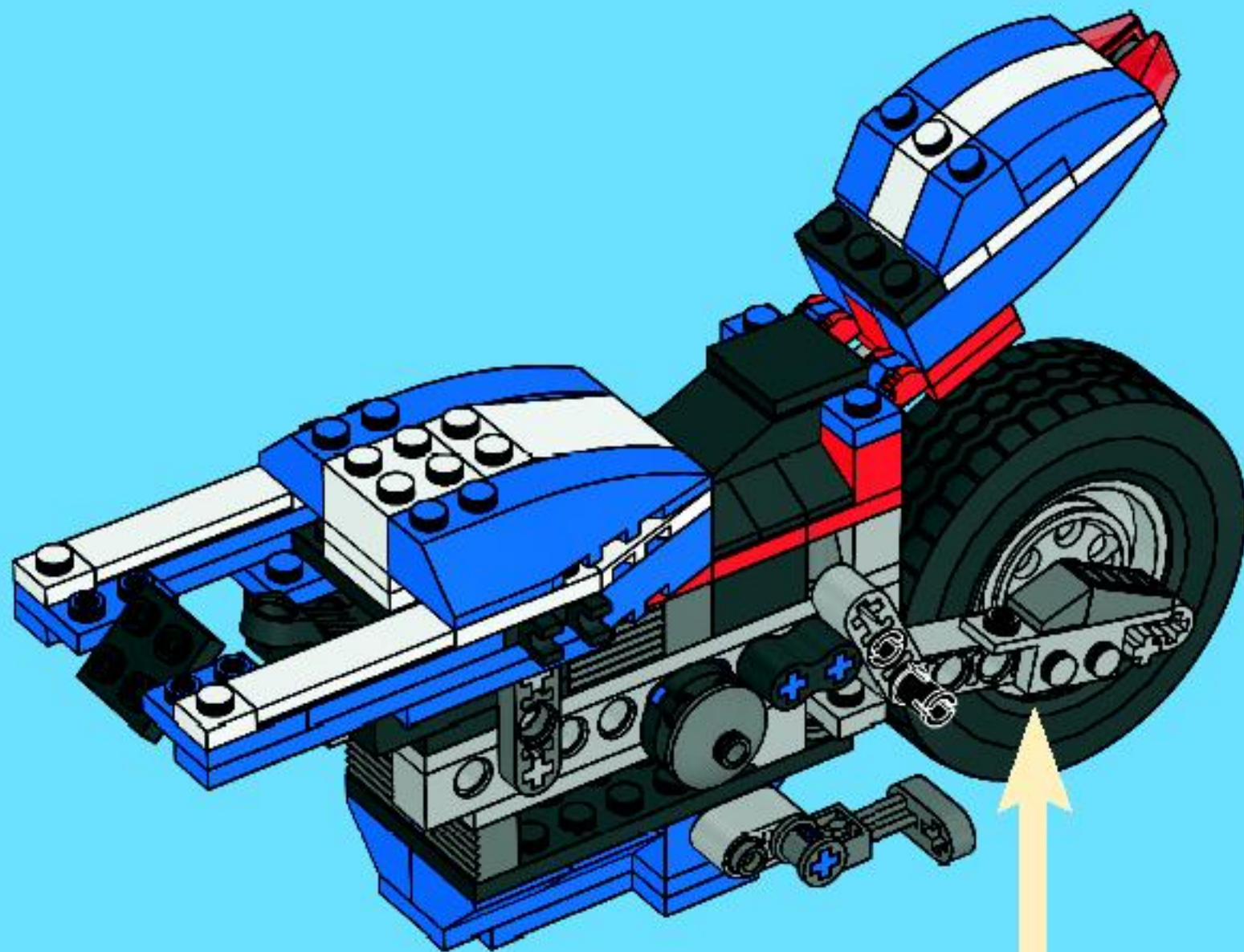

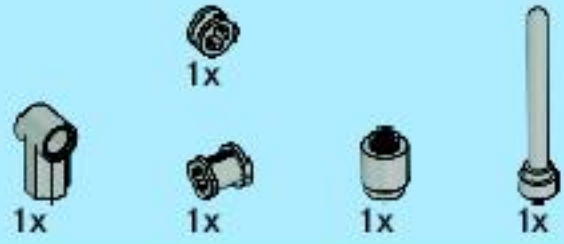

42

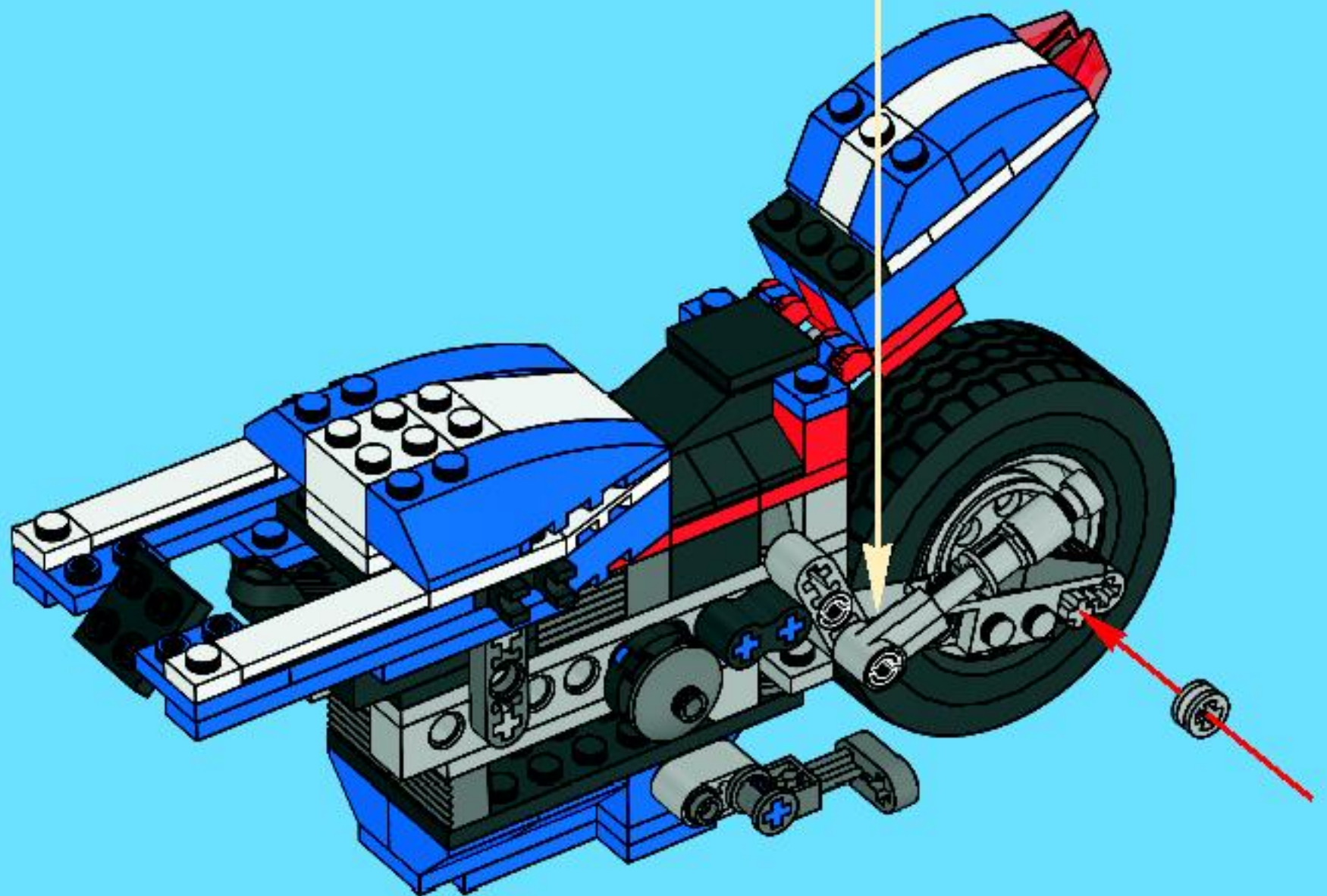
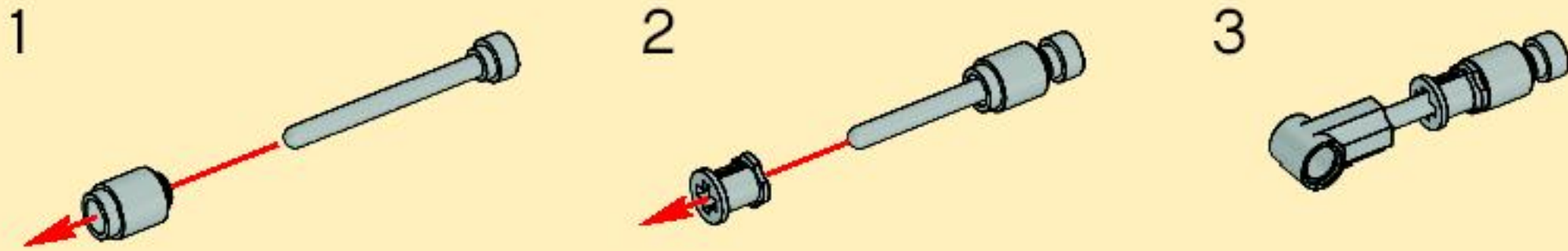

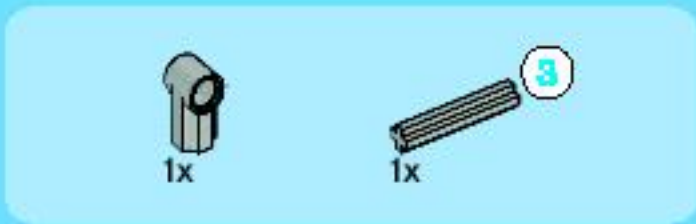
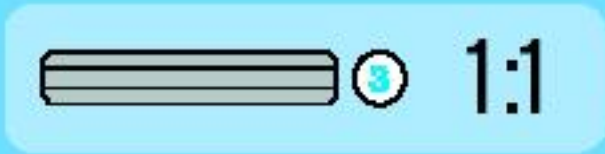
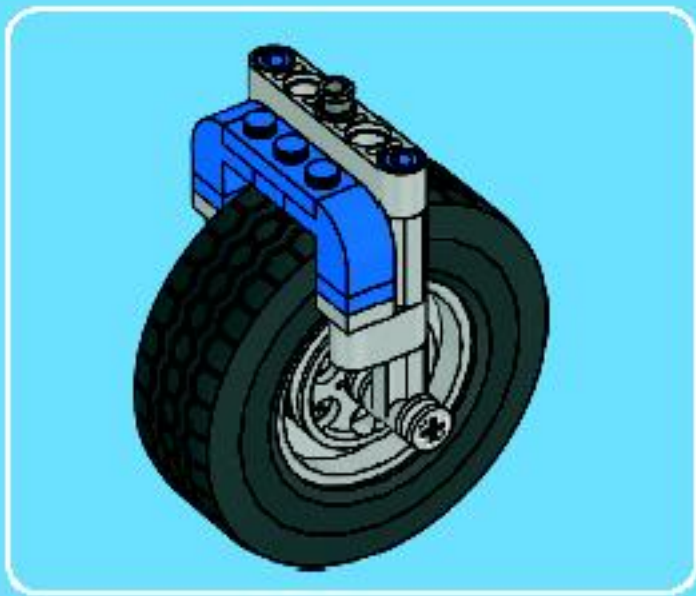

1

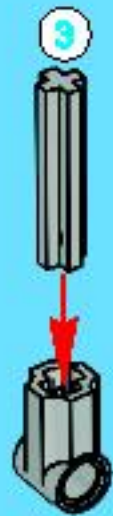

2

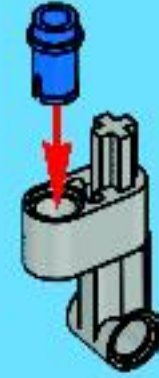

3

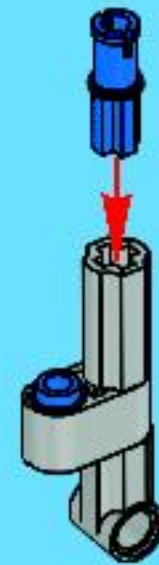



1x



1x



1:1

4

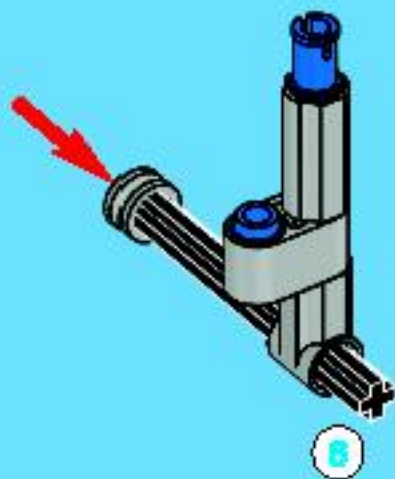

1x

5

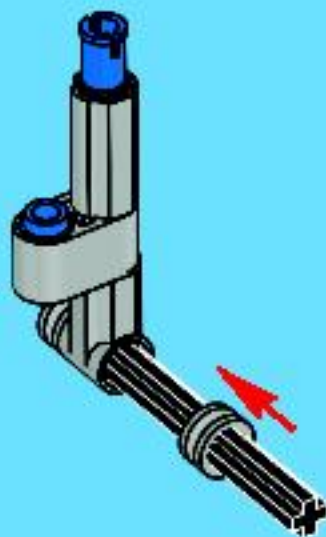

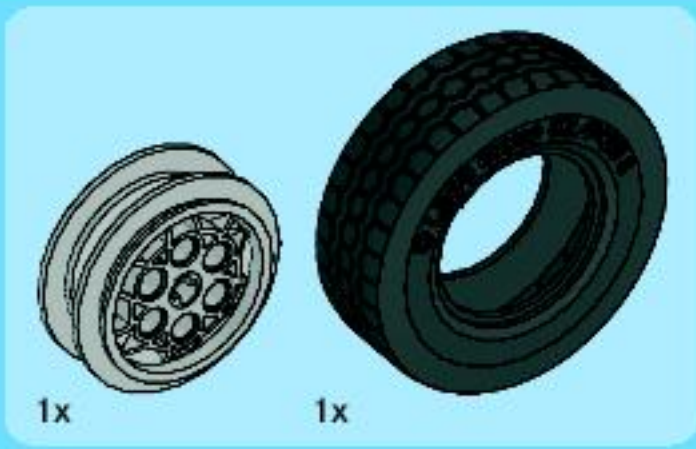

6

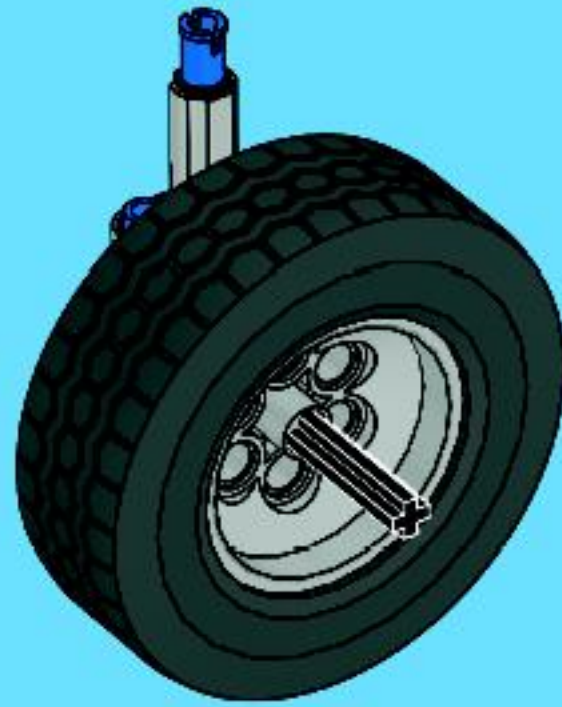

7

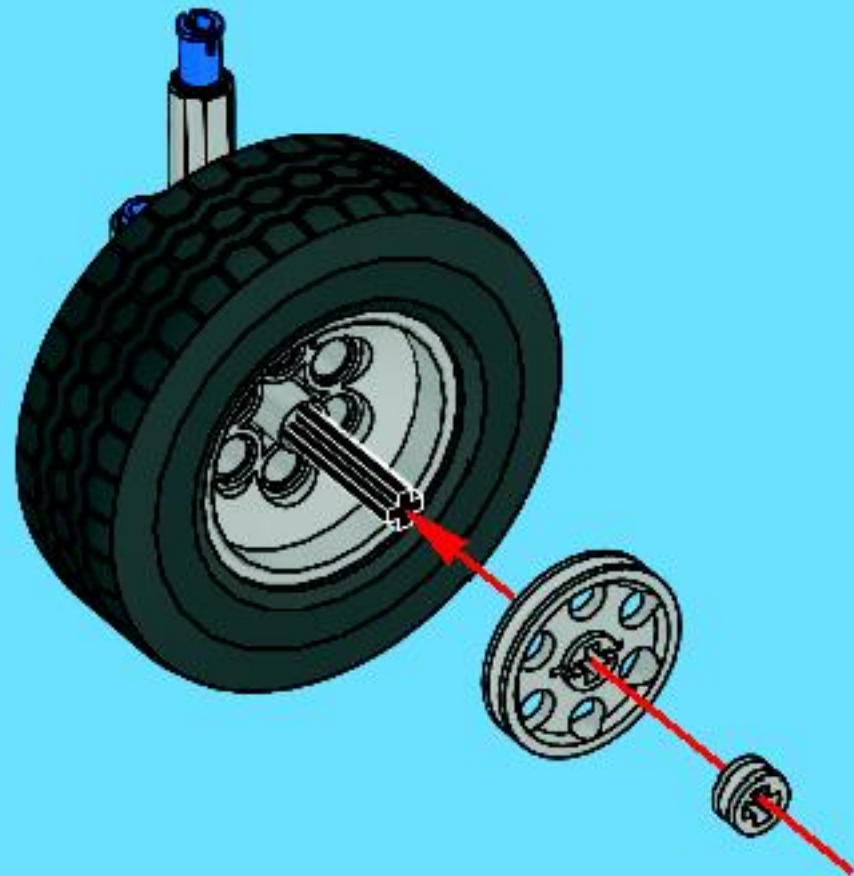

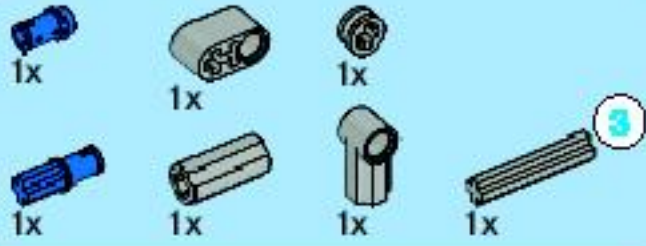

8

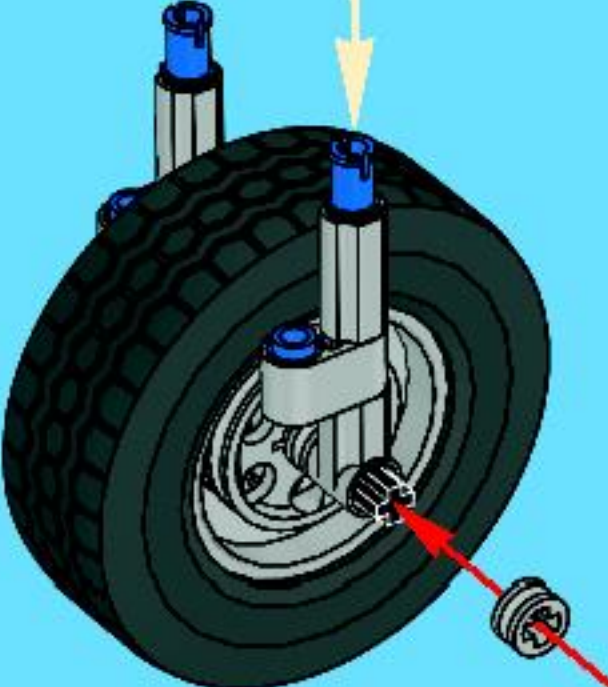
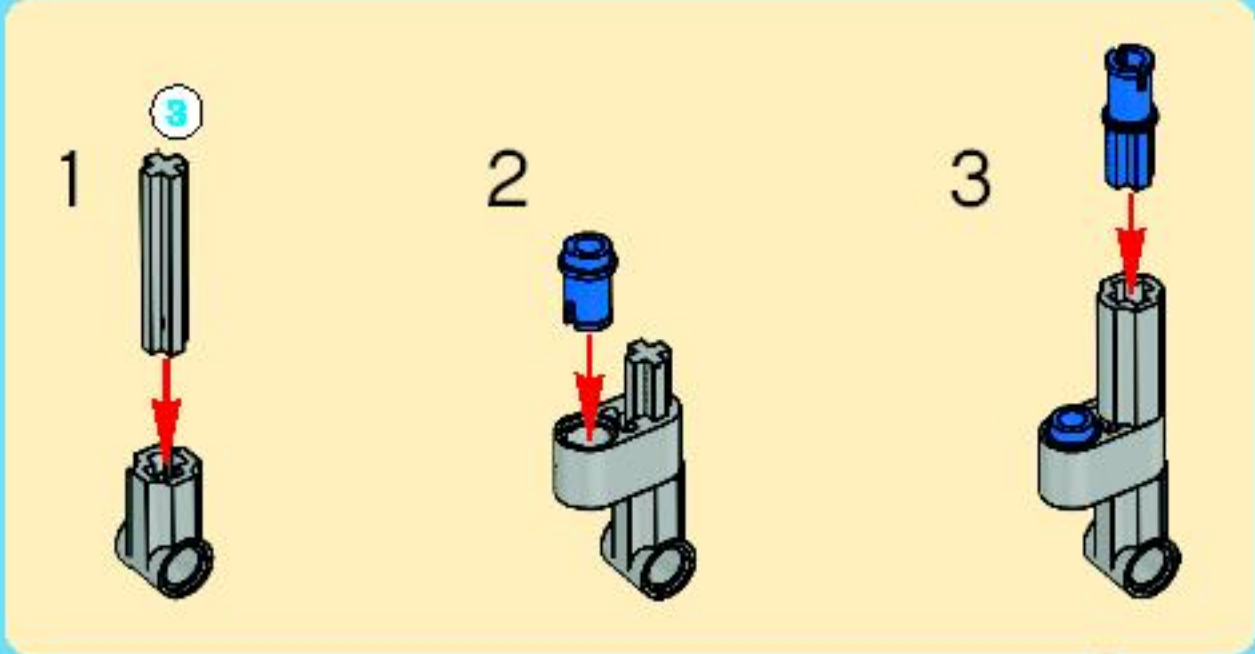



1x



1x

9

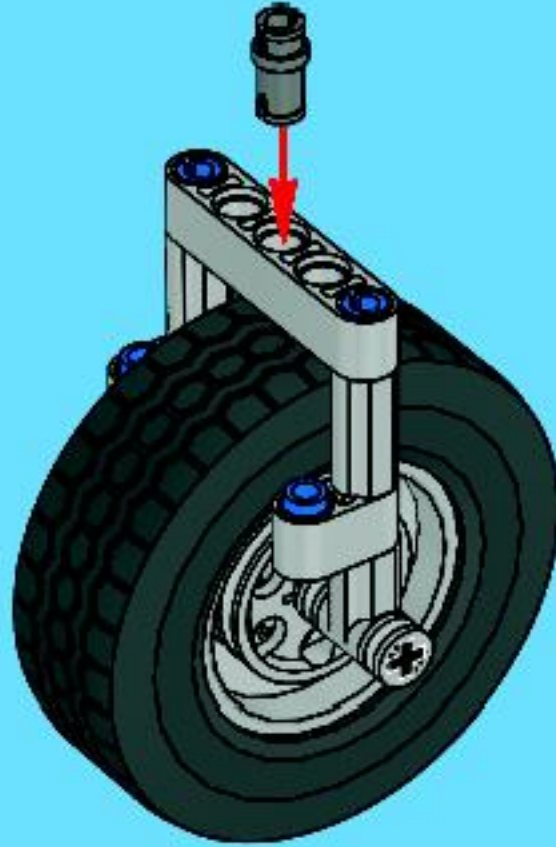



2x



3x



1x



2x

10

1

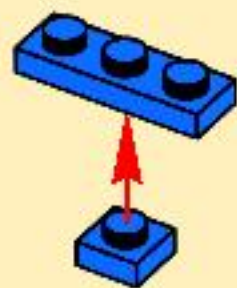

2

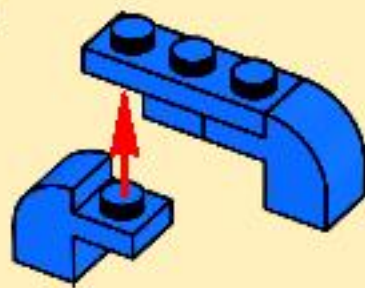

3

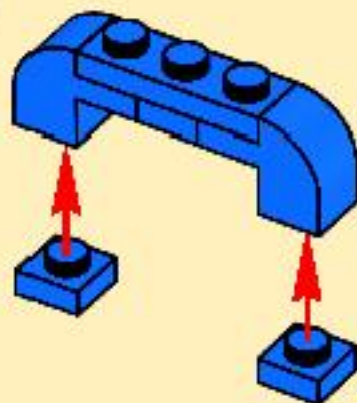

4

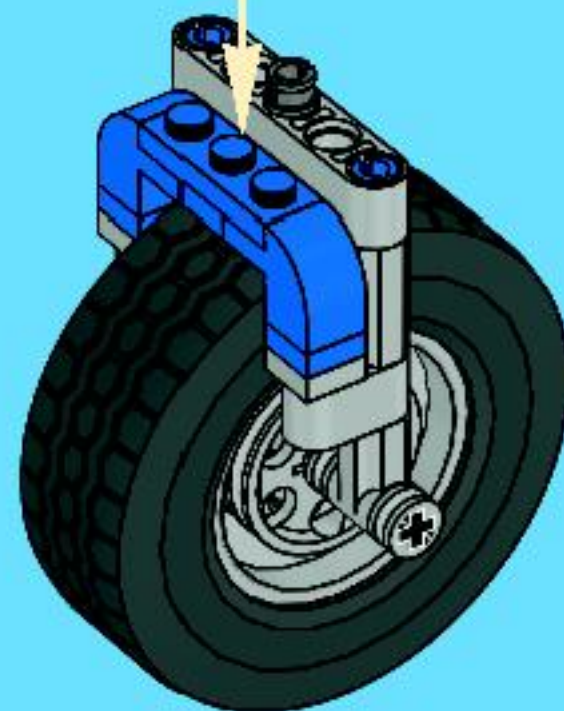
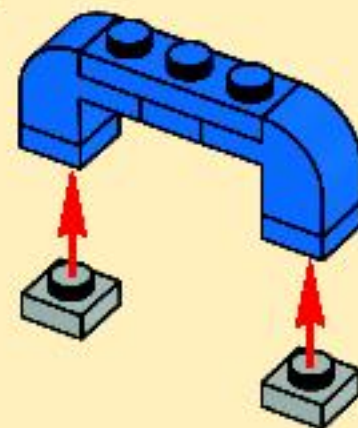

43

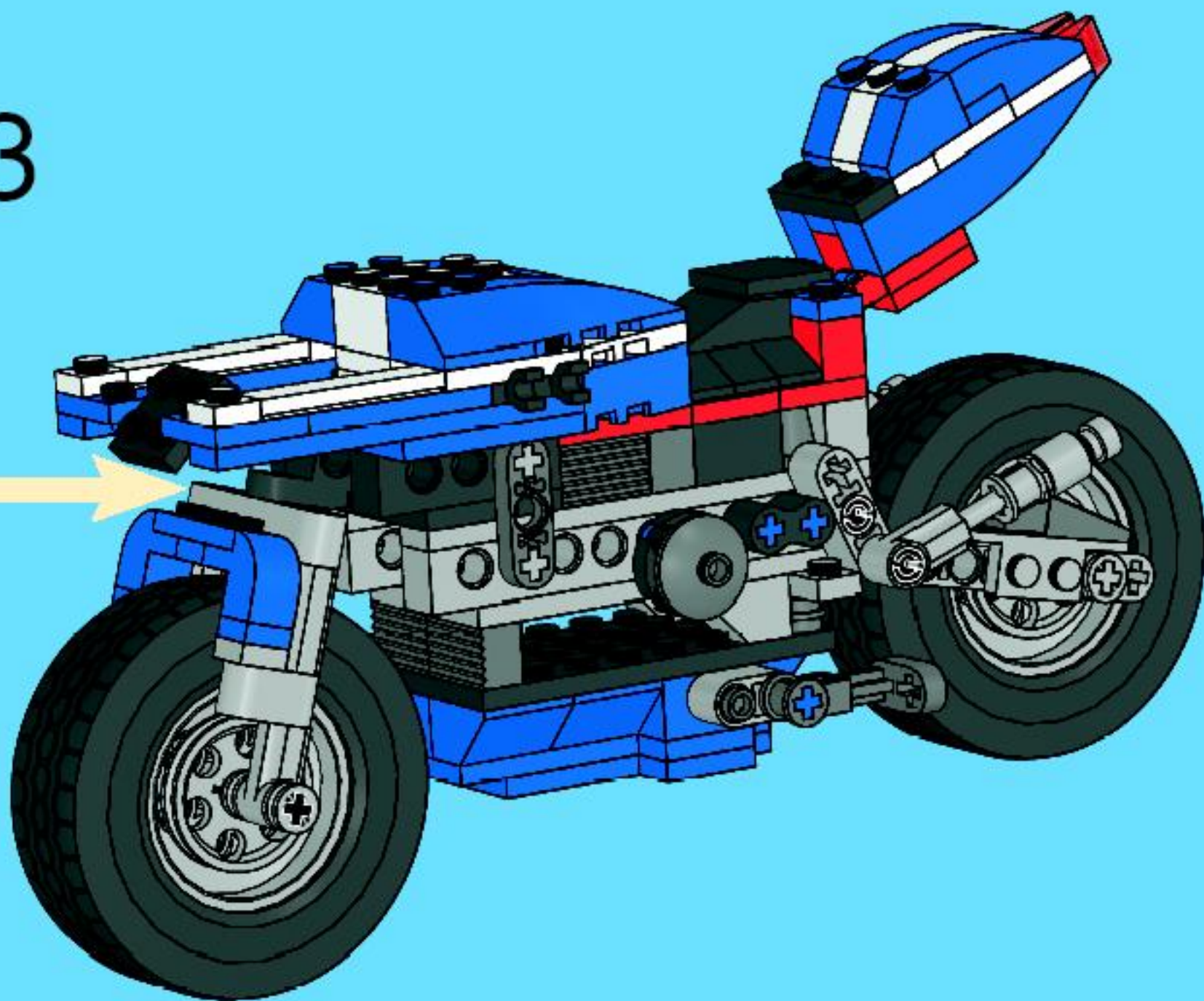

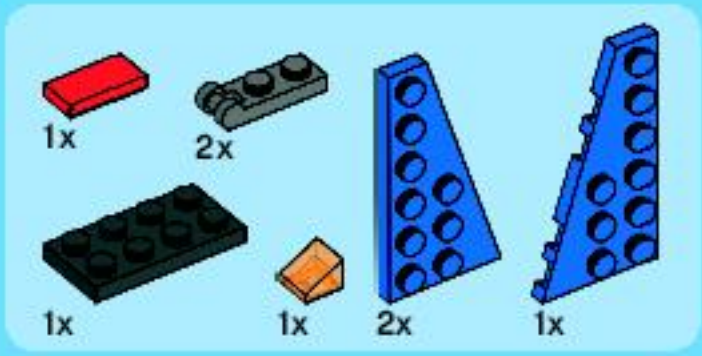

44

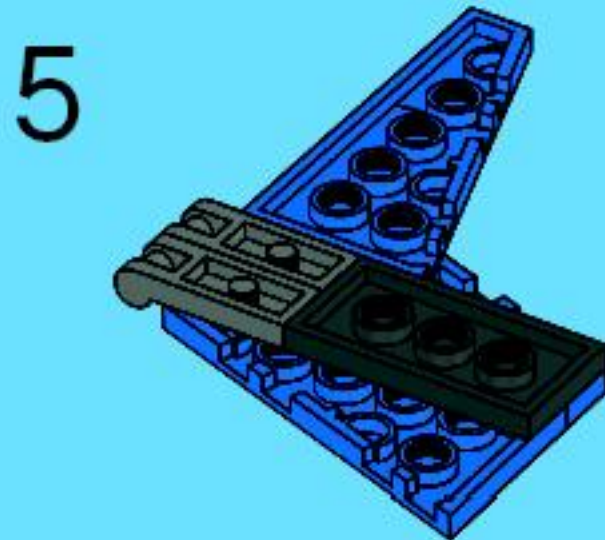
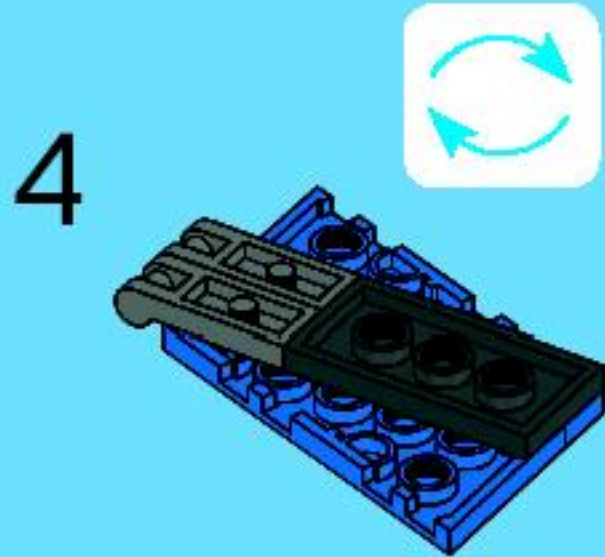
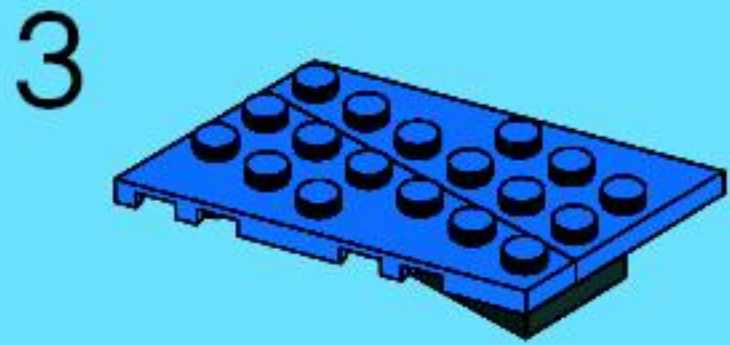
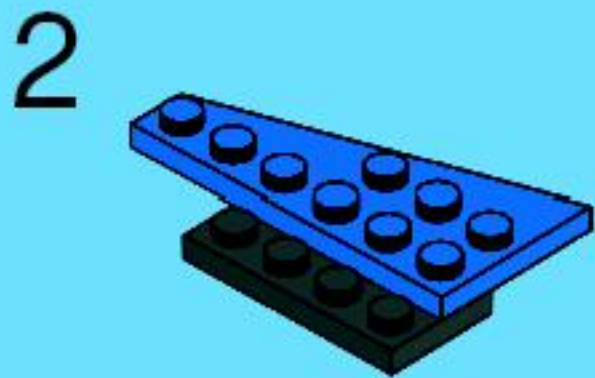

6

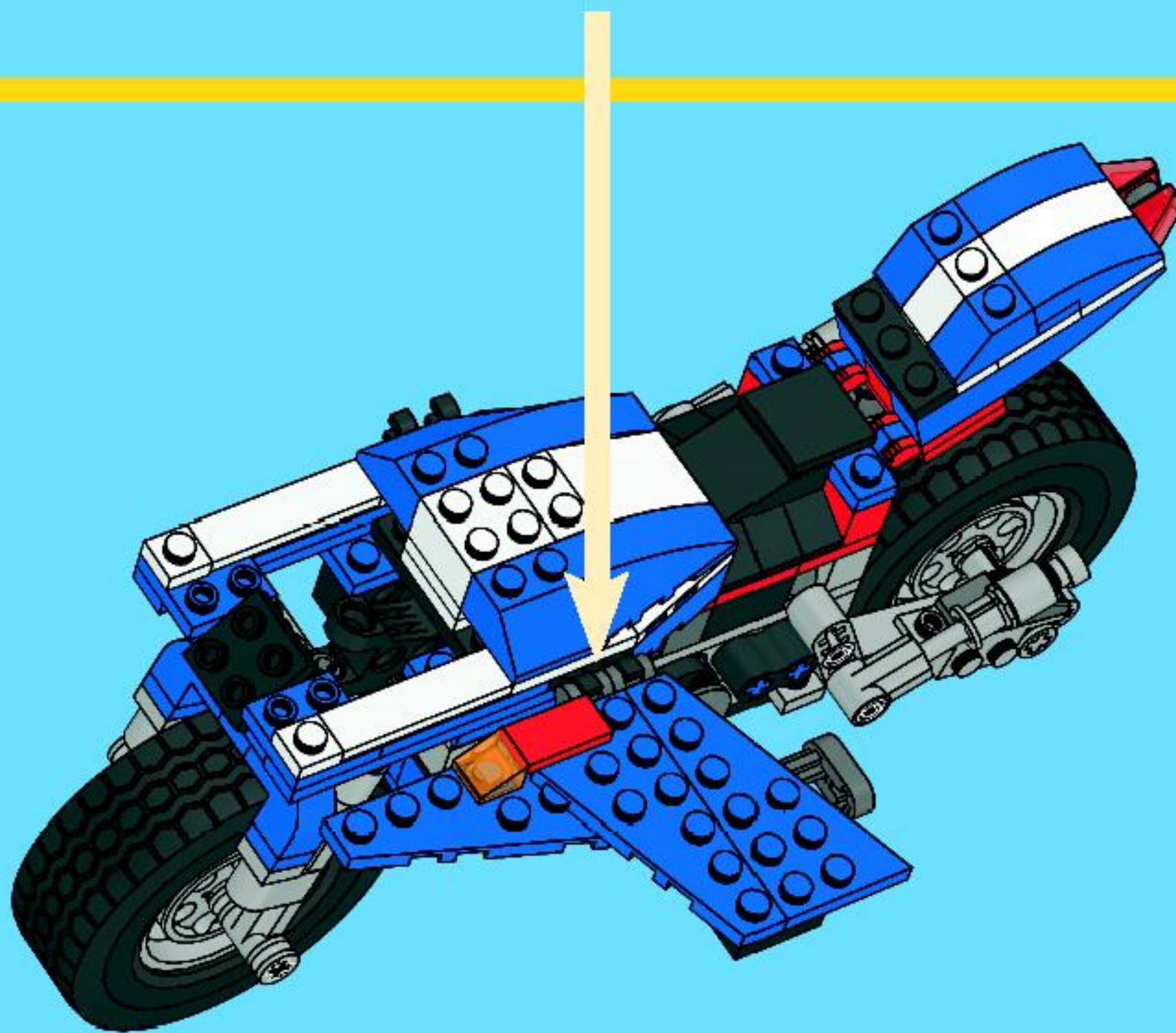
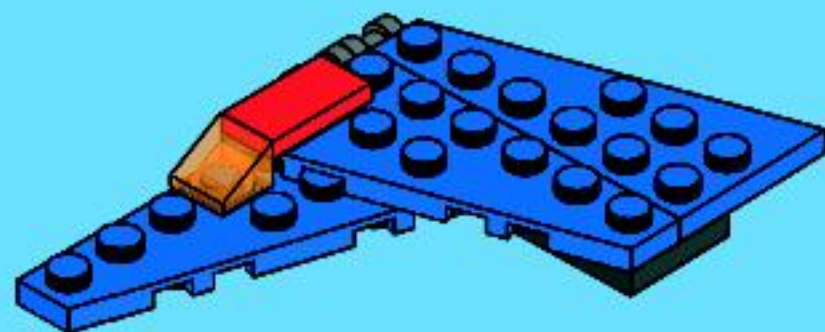

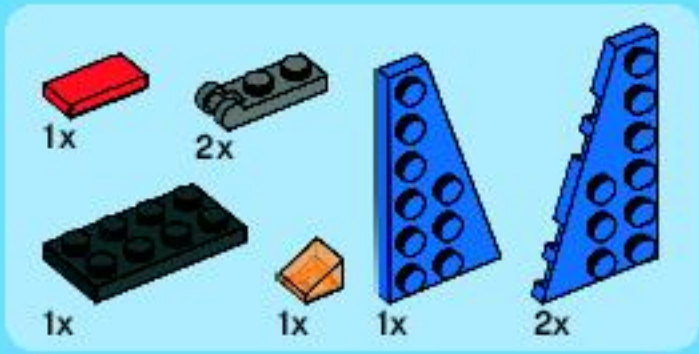

45

1

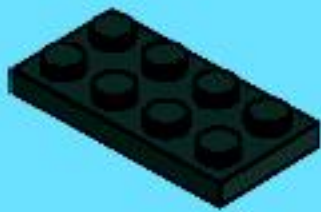

2



3

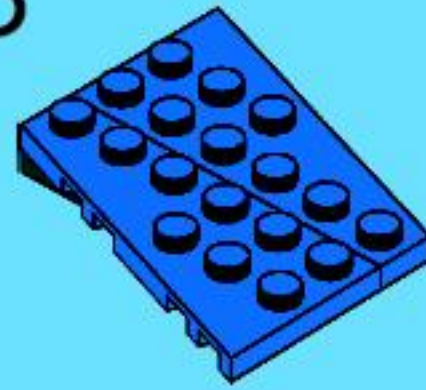

4

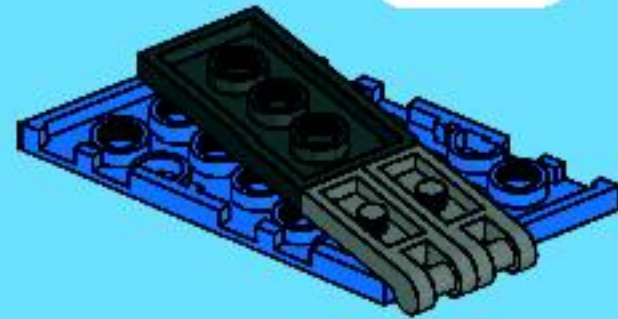

5





6

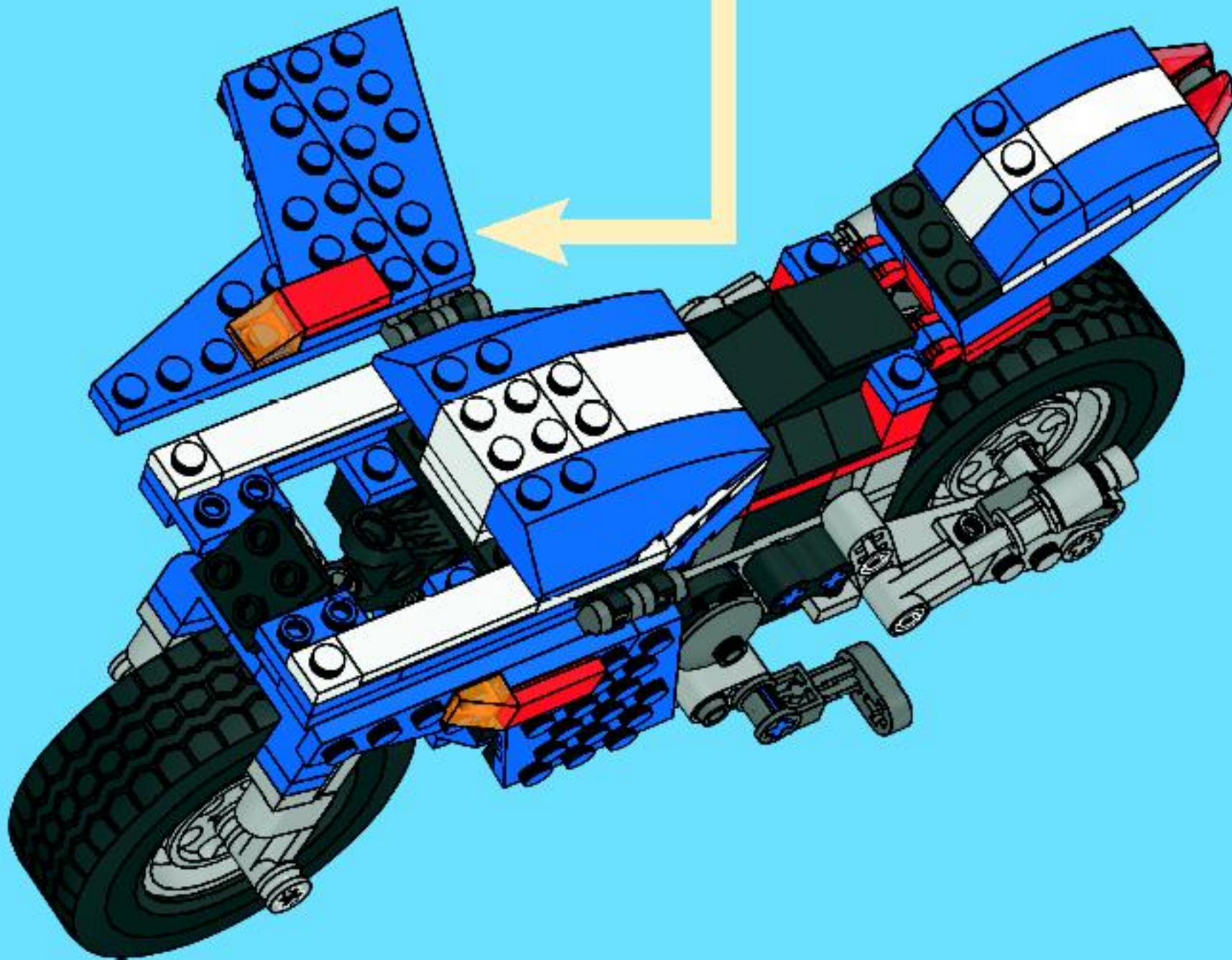
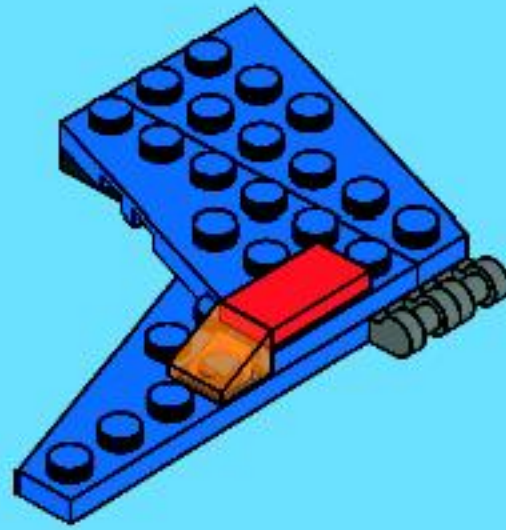



2x



1x



2x



2x

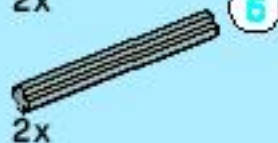

2x

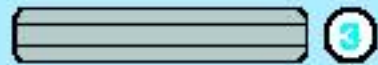

3



5

1:1

46

1



2

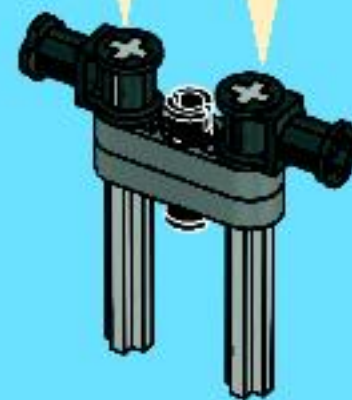

3

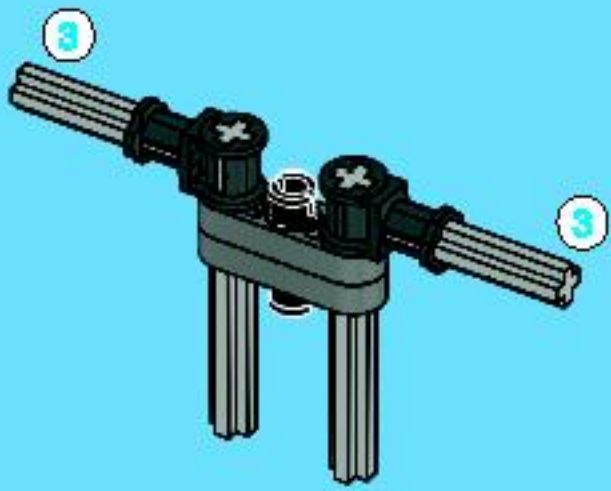

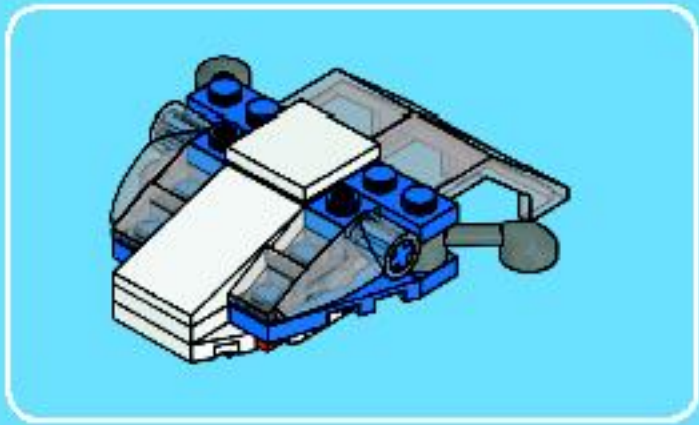

1x

1



1x

2

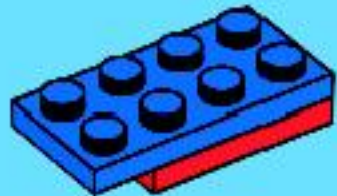

2x



1x

3

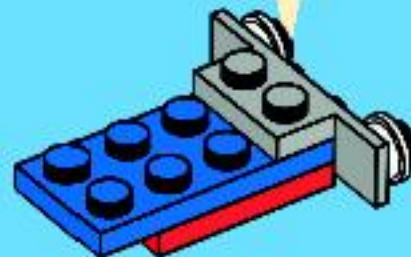
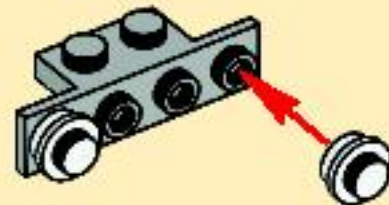



2x

4



2x



1x

5

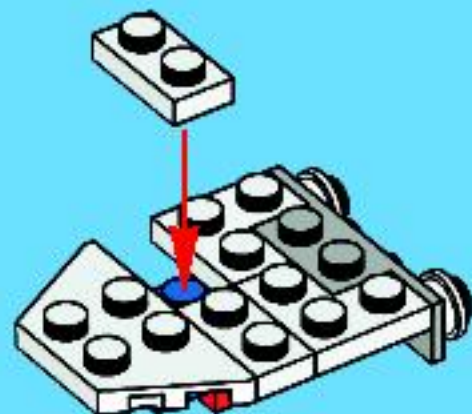

1x

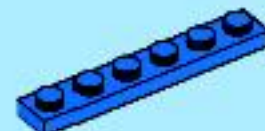

1x

6



1x



1x



1x

7

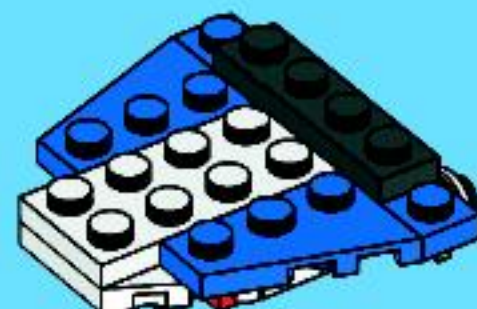



2x



2x

8

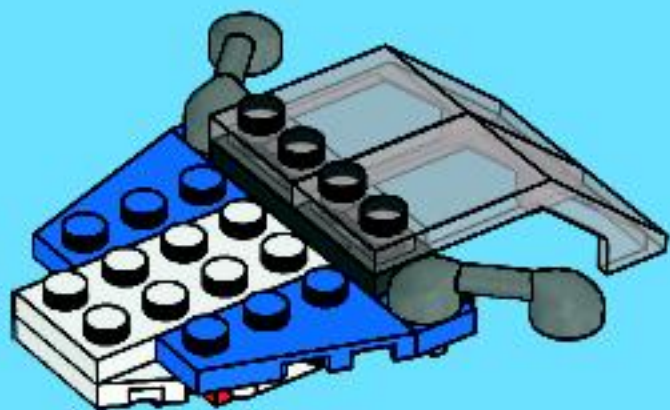

2x

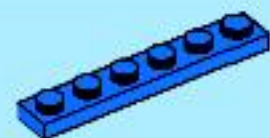

1x

9

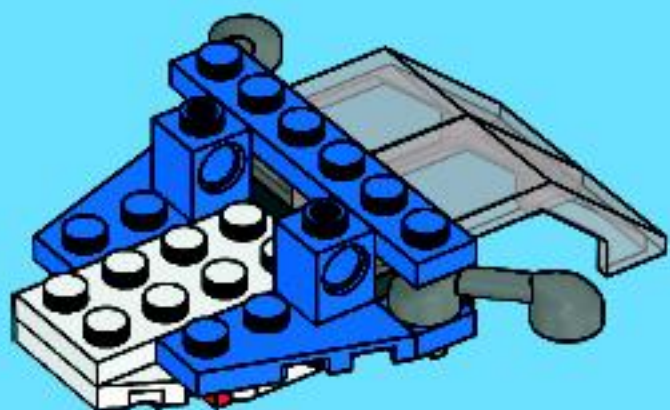

2x



4x

10



2x

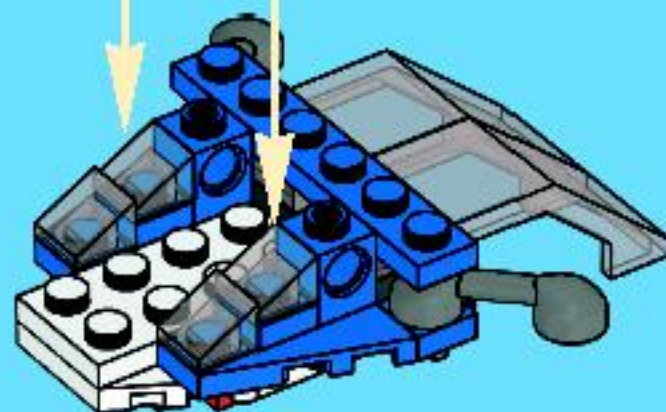

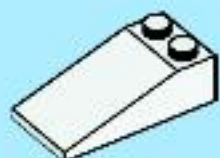

1x

11

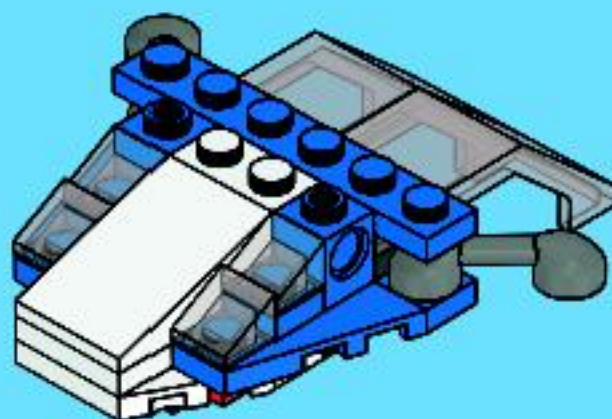

2x



2x

12

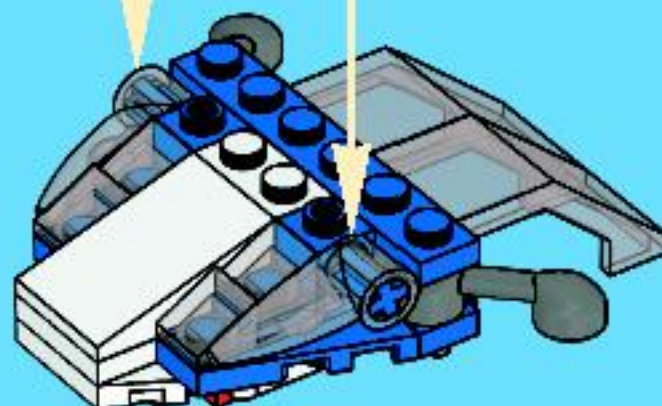
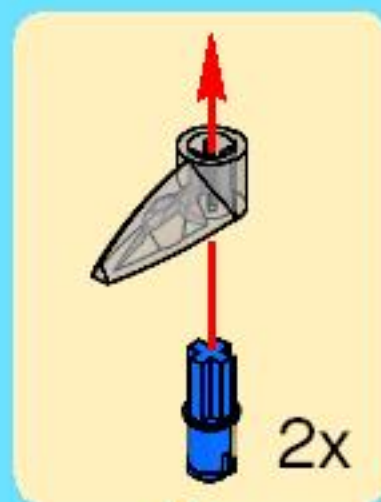



1x

13

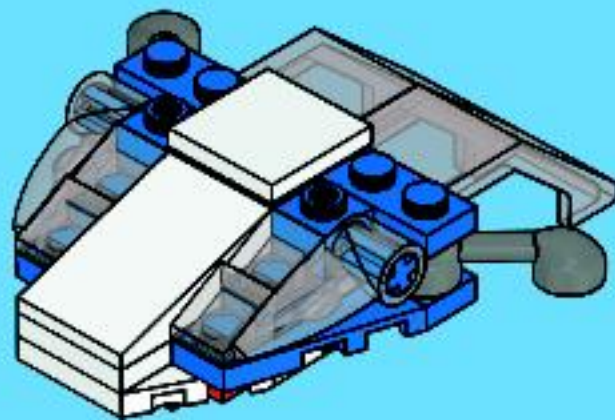

47

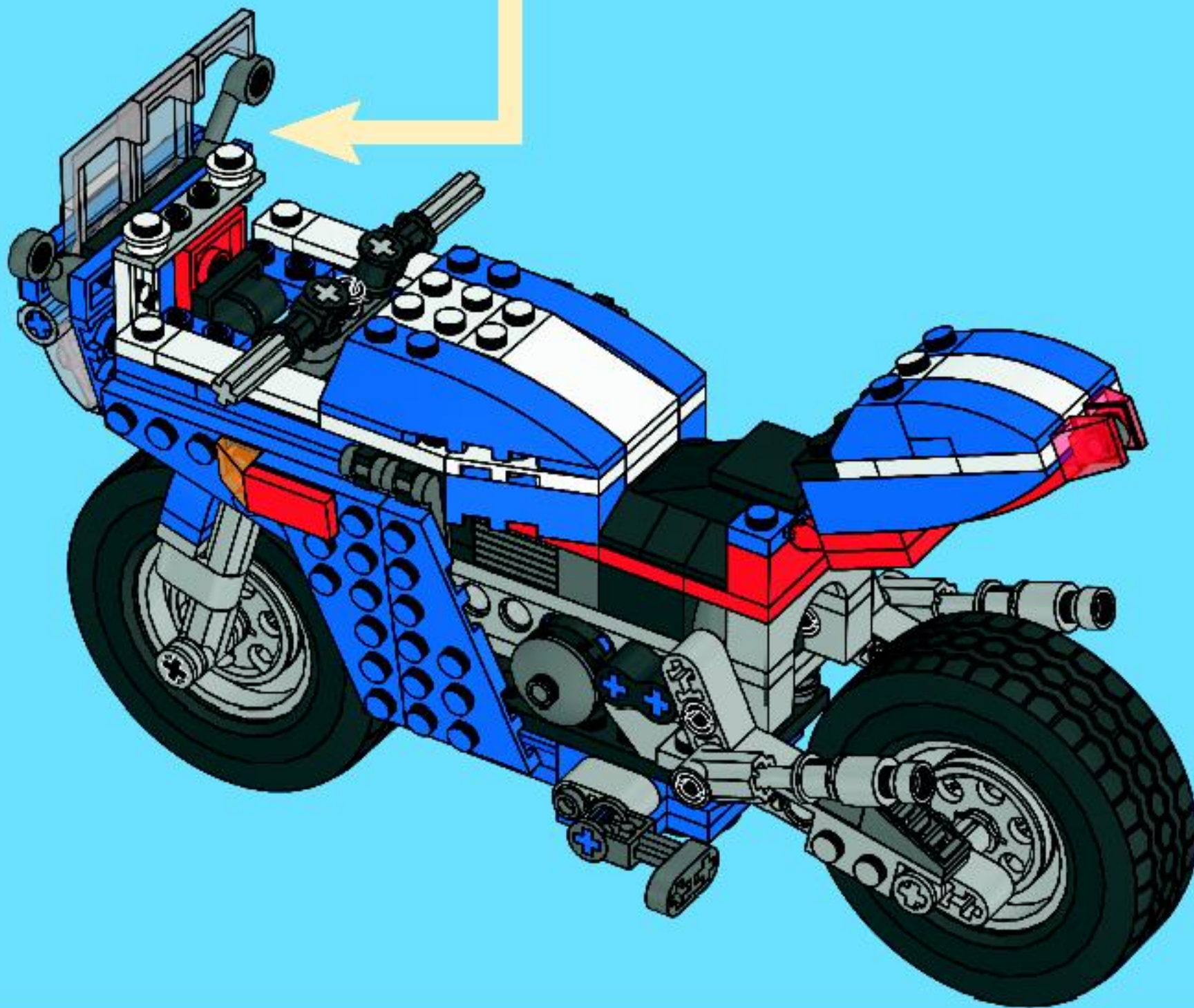

48

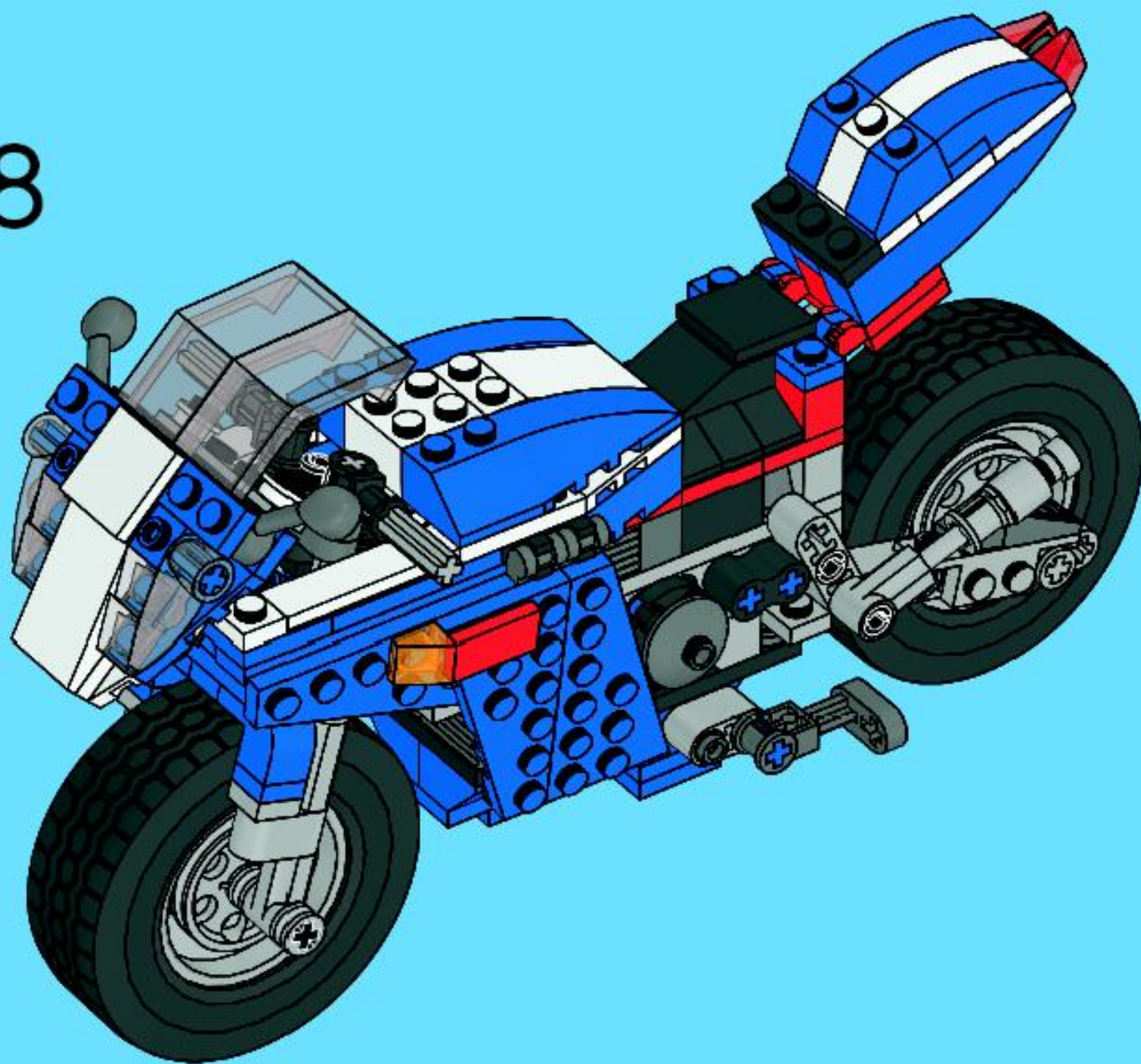



1x
300301



1x
4249112



2x
242001



2x
243101



1x
306801



2x
302401



5x
302301



3x
362301



2x
302101



2x
302001



1x
379501



1x
4249506



1x
4179875



1x
4179874



1x
4121932



2x
4143000



2x
614101



2x
4244369



2x
4244363



1x
4211050



1x
4211086



1x
4211103



4x
4223767



2x
4210676



1x
4210665



1x
4210828



2x
4529240



2x
4211010

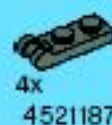

4x
4521187



4x
4210636



2x
4504378



2x
4540386



6x
4210633



1x
4210980



2x
4543604



2x
4160407



2x
4189123



2x
4543998



11x
4206482



10x
4143005



1x
4540057



1x
4540056



1x
4160106



1x
4498156



5x
302423



3x
302323



3x
362323



2x
371023



1x
4527639



2x
366623

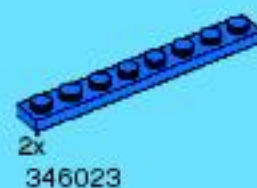

2x
346023



5x
302023



1x
379523



1x
4160128



1x
4498155



3x
4543090

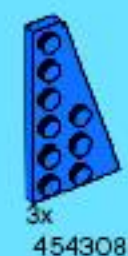

3x
4543089



2x
4121936



5x
366023



2x
4529003



2x
4119014



2x
4543608



4x
4244368



2x
4204624

2x
4107081

7x
4121715

2x
370626

2x
4198367

1x
306826

1x
4543263

2x
4519849

1x
362326

3x
371026

2x
403226

1x
302126

3x
302026

4x
300426

6x
4504382

1x
329826

2x
370126

1x
281726

2x
281526

2x
4235705

1x
303526

1x
301021

1x
4160406

2x
306921

2x
4183050

2x
362321

2x
302121

2x
302021

1x
4142865

6x
4211573

4x
4211622

4x
4211550

3x
4282740

3x
4515184

1x
4211435

4x
4211815

4x
4211639

1x
4211805

2x
4512360

2x
4211399

2x
4251149

1x
4211438

2x
4211406

2x
4496707

2x
4211437

2x
4211412

1x
4278273

1x
4211651

2x
4211624

2x
4211374

2x
4494222

2x
4211473

Customer Service
Kundenservice
Service Consommateurs
Servicio Al Consumidor

www.lego.com/service or dial



: 00800 5346 5555

: 1-800-422-5346



www.nielsen.com/LEGO



WIN LEGO® PRODUCTS

Fill out a survey and you might WIN a cool LEGO product!
NO PURCHASE NECESSARY

Open to all residents where not prohibited
Go to www.nielsen.com/LEGO to fill out a survey for a chance to win a LEGO product.

WIN LEGO® PRODUCTEN

Vul een enquêteformulier in en maak kans op een cool LEGO® product!
Kopen niet nodig
Iedereen uit landen waar geen enquêteverbod geldt mag deelnemen.
Ga naar www.nielsen.nl/mid/LEGO, vul een enquêteformulier in en maak kans op een LEGO product.

GEWINNE LEGO® PRODUKTE

Nimm an der Umfrage teil und GEWINNE ein tolles LEGO® Produkt!
Die Teilnahme am Gewinnspiel führt zu keinerlei Kaufverpflichtungen
Teilnahme in allen nicht ausgeschlossenen Ländern möglich
Wir verlosen unter allen Teilnehmern der Umfrage auf www.nielsen.nl/mid/LEGO LEGO Produkte.

GAGNE DES PRODUITS LEGO®

Réponds à un questionnaire et tu pourrais GAGNER un produit LEGO® très cool !
Aucune obligation d'achat
Ouvert à tous les résidents des pays autorisés.
Visite www.nielsen.nl/mid/LEGO pour répondre à un questionnaire et avoir une chance de gagner un produit LEGO.

レゴ®製品を「当てよう」

アンケートに記入して、かっこいいレゴ®製品を当てよう！
お買い上げの必要はありません。
禁止されていない限り、すべての皆様にご利用いただけます。
www.nielsen.com/LEGOにアクセスして、アンケートにご記入ください。当選者にはレゴ製品を差し上げます。



www.LEGO.com