

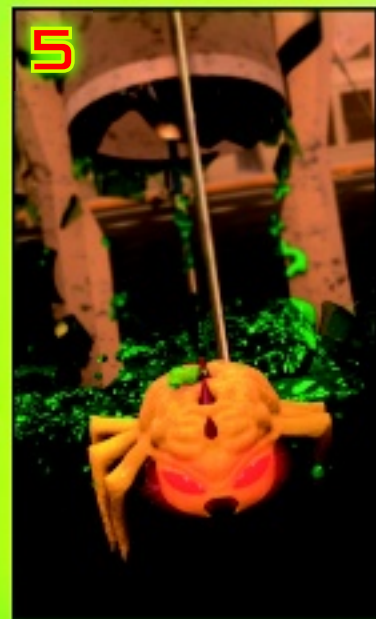

HERO FACTORY

44014







LEGO.com/herofactory

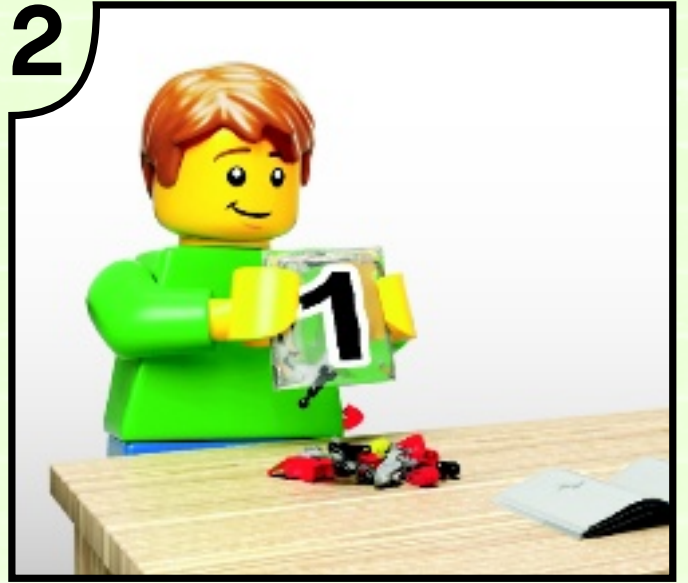

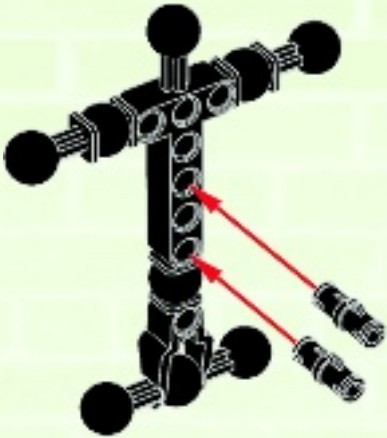
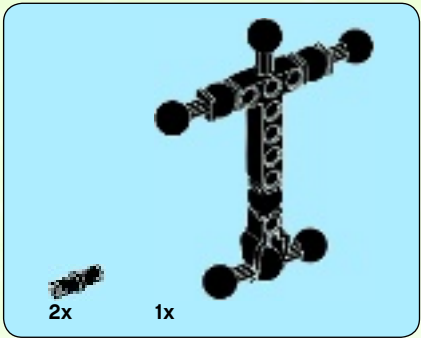
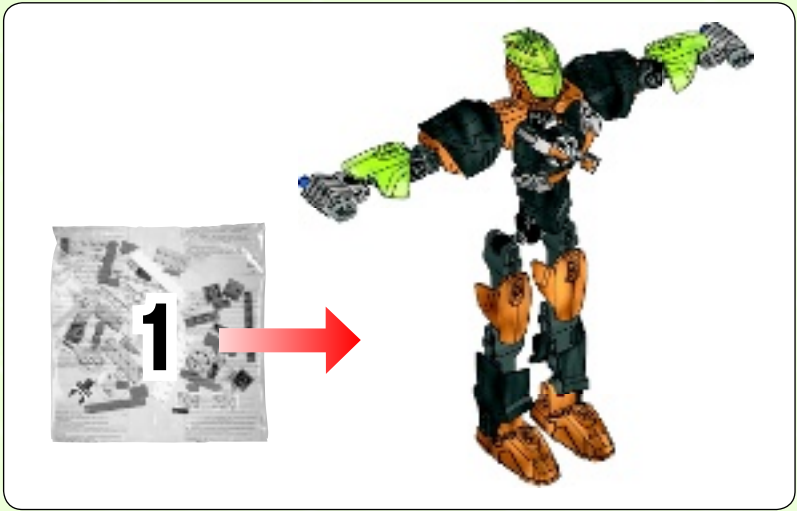

1



1x

2



2x

3





4

1



2



3



2x

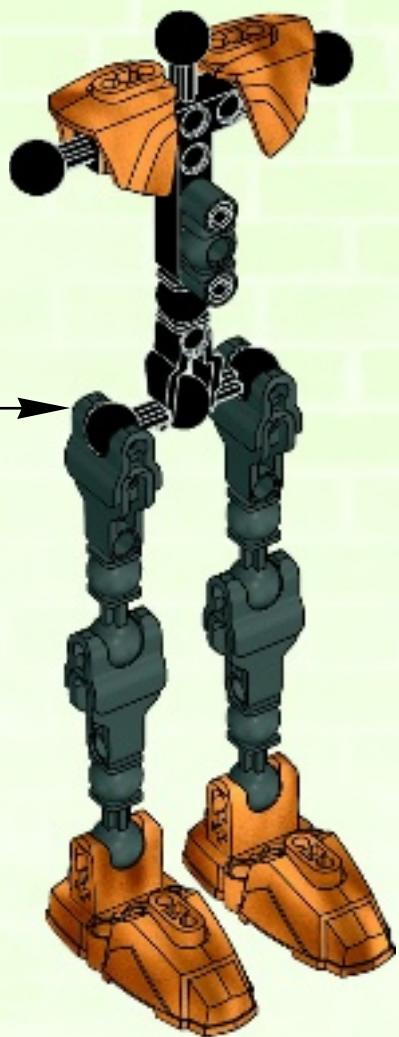

5

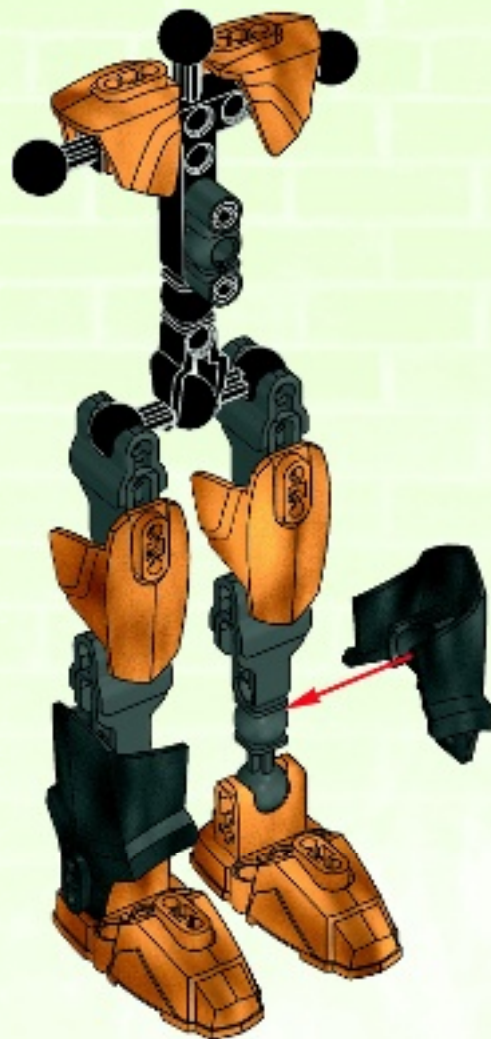

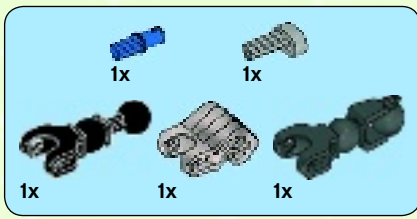

6

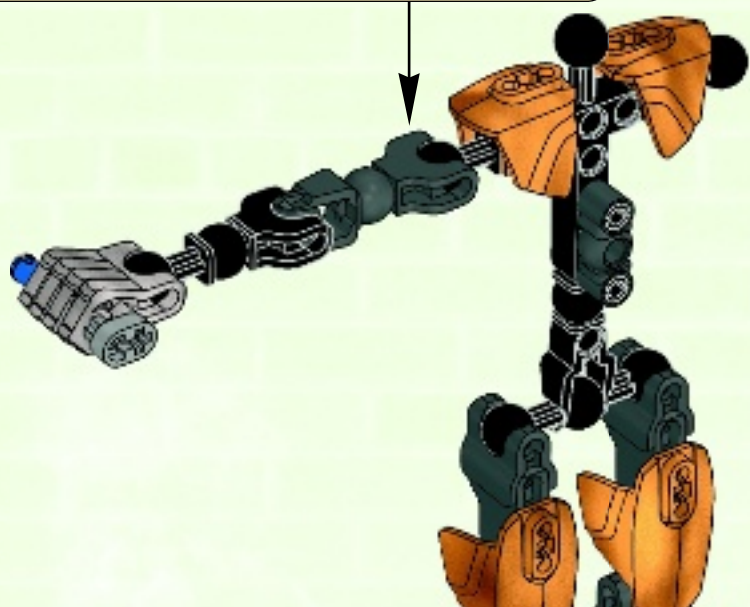
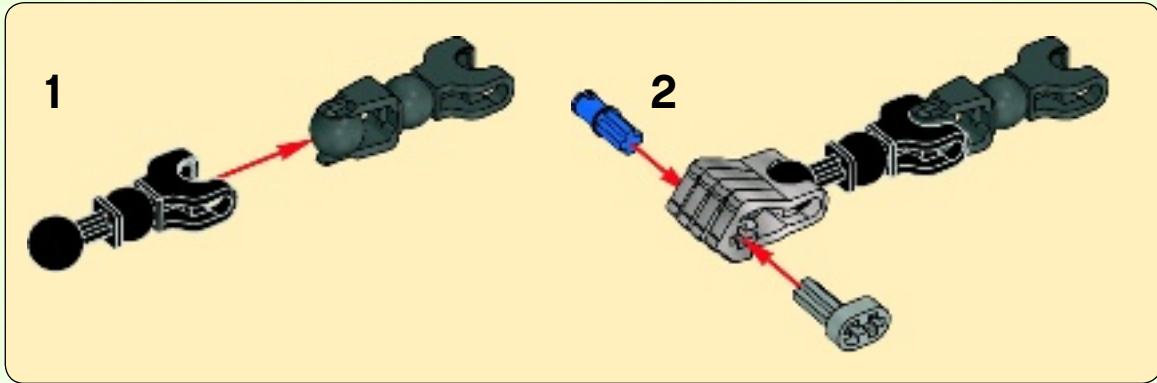

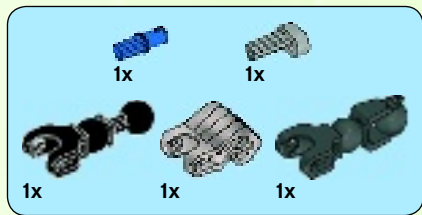

7

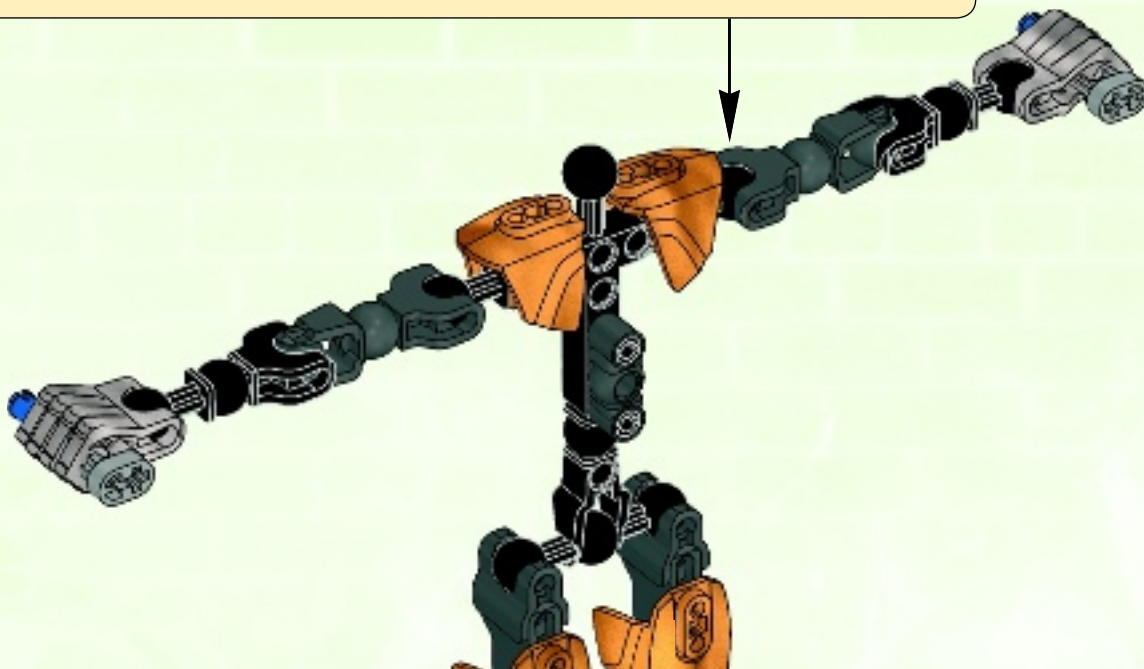
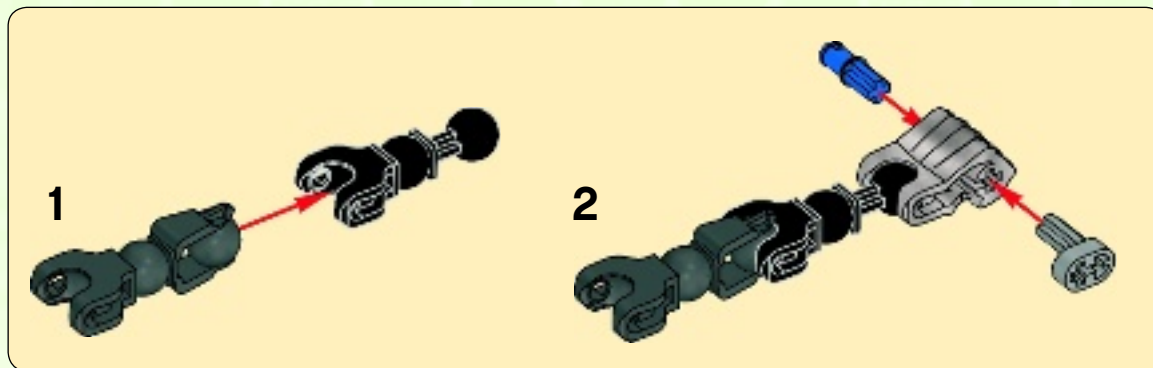

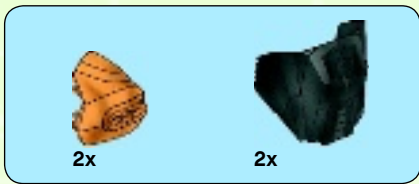

8

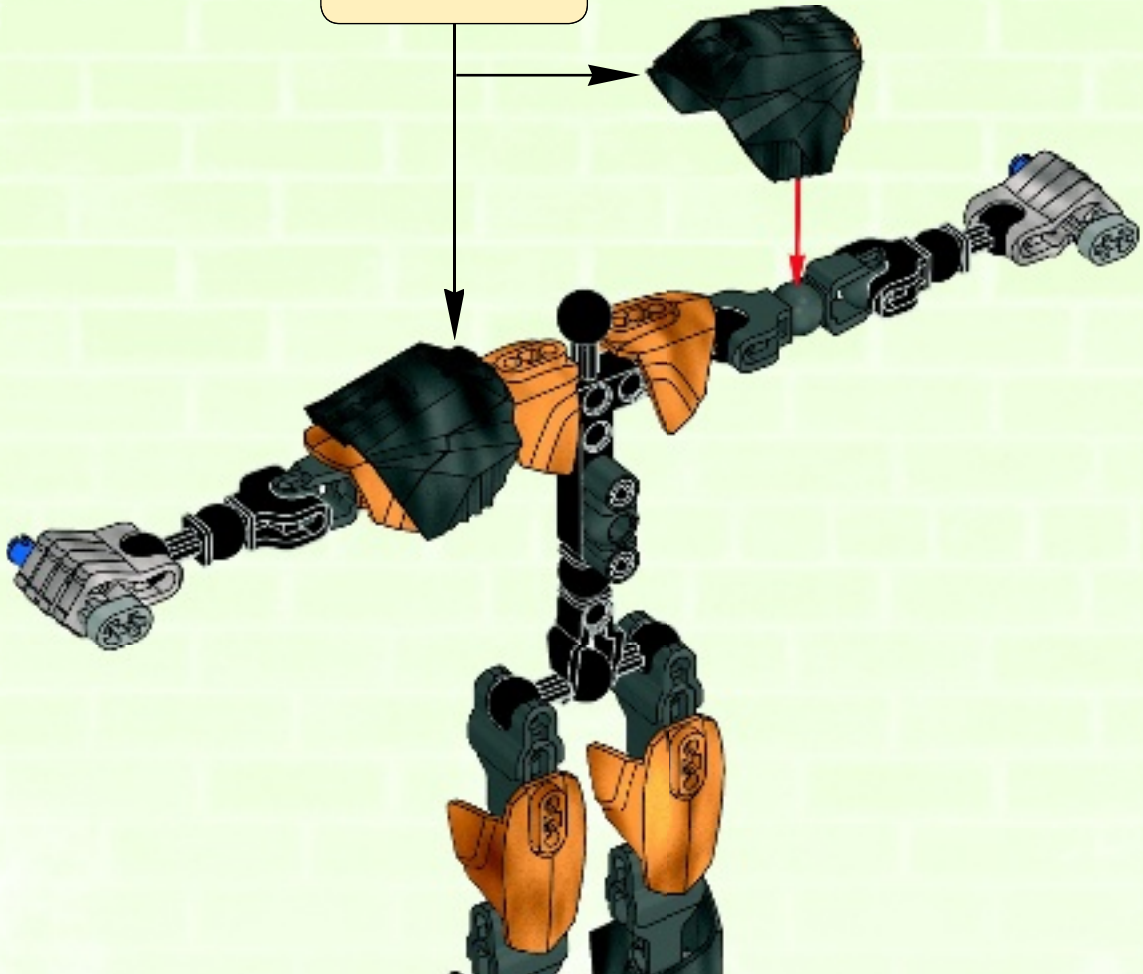
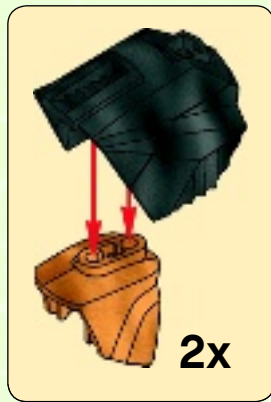

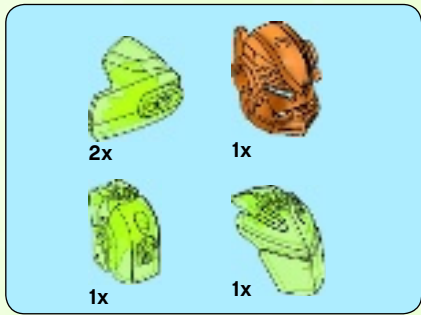

9

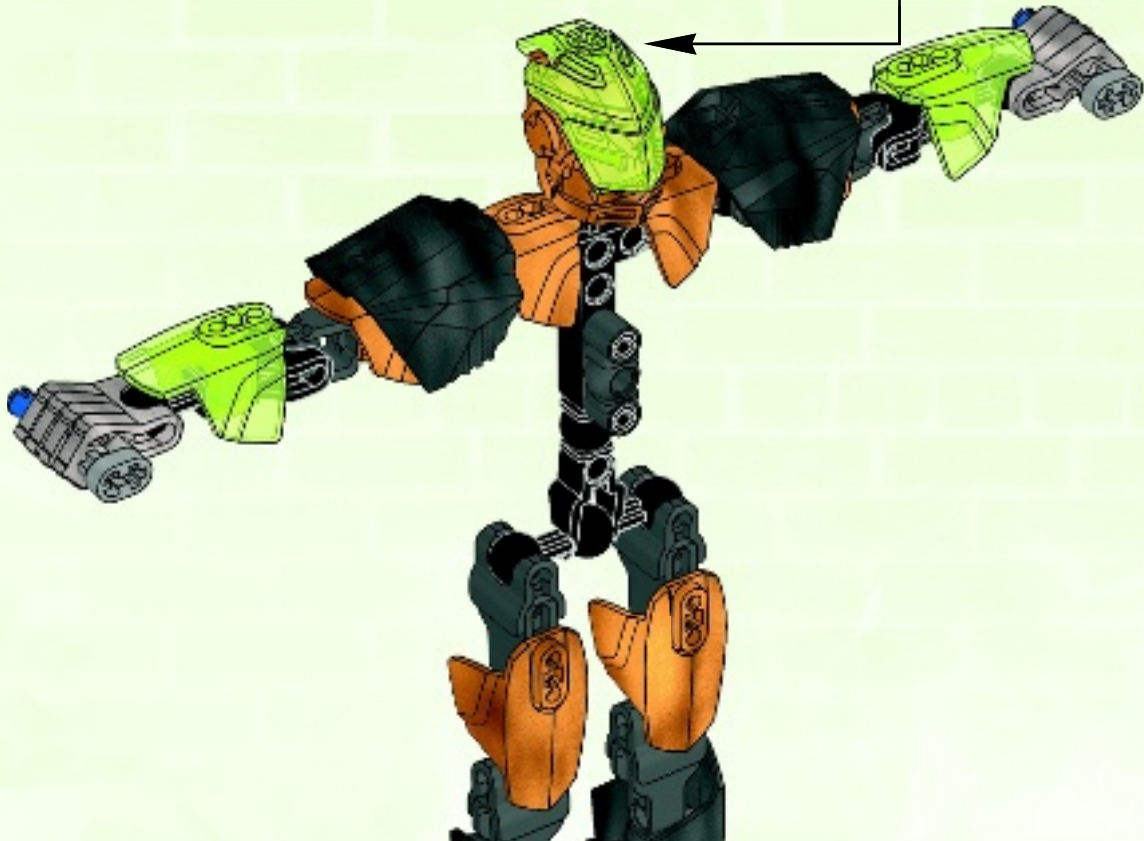
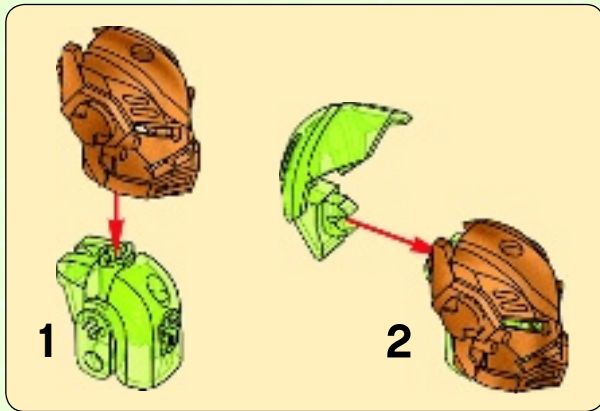



10

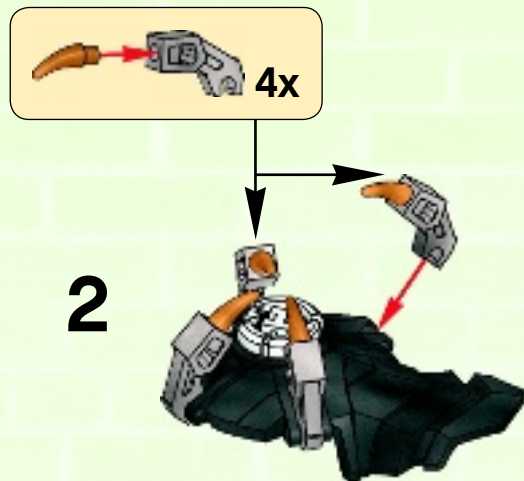



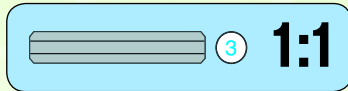
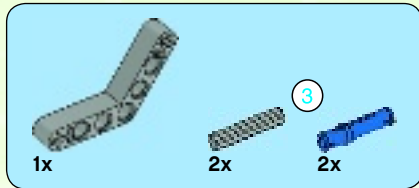
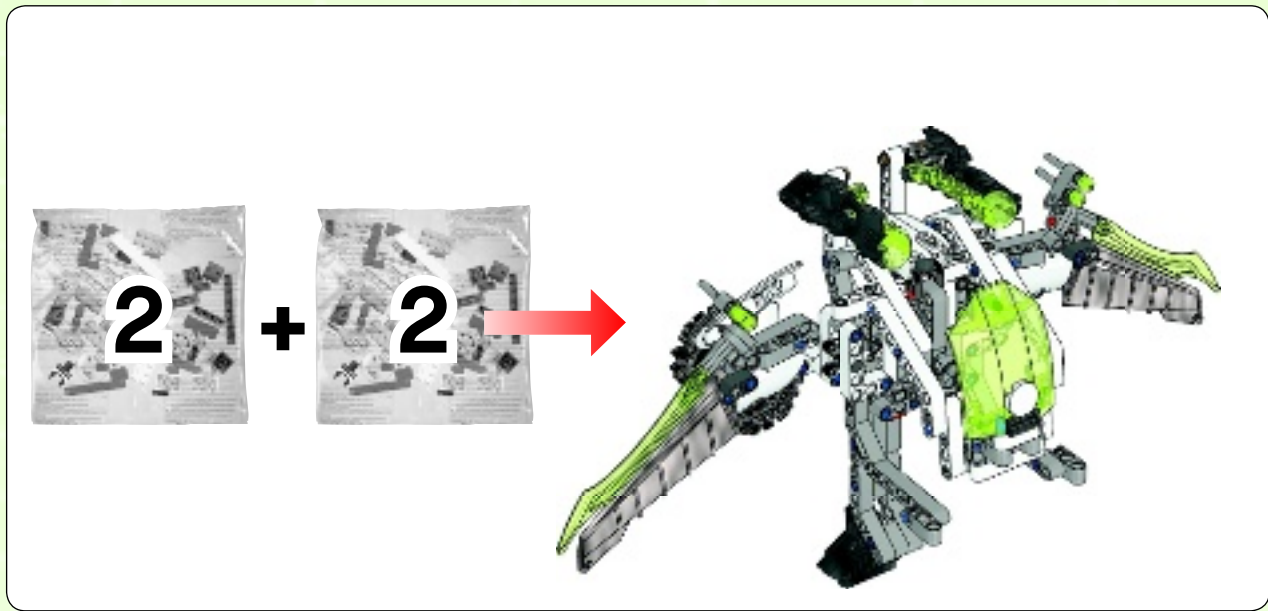

1

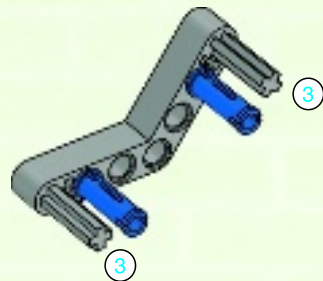

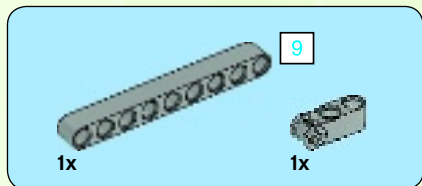

2

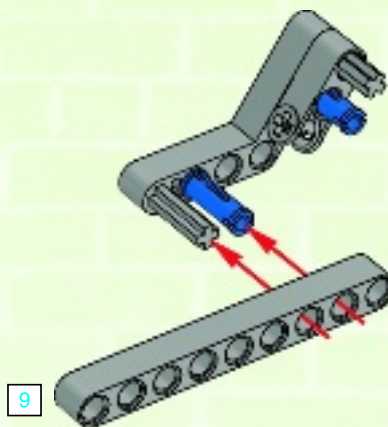

3

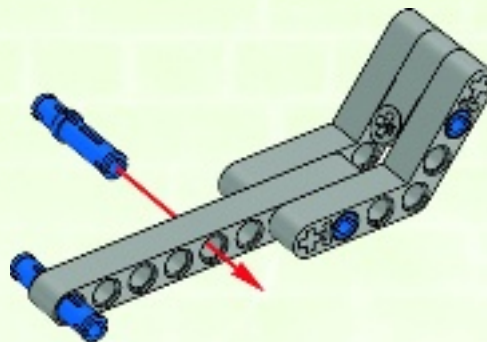

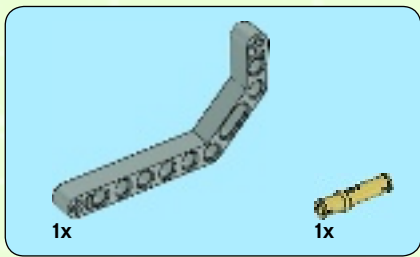

4

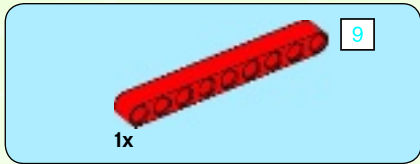
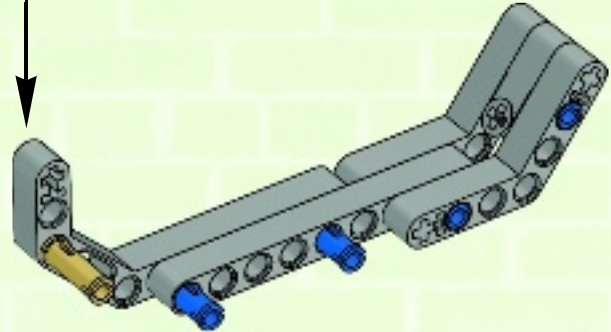
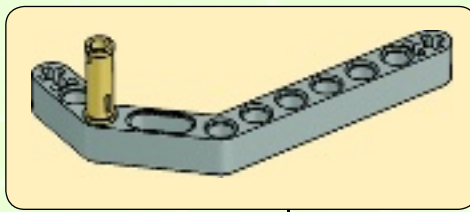

5

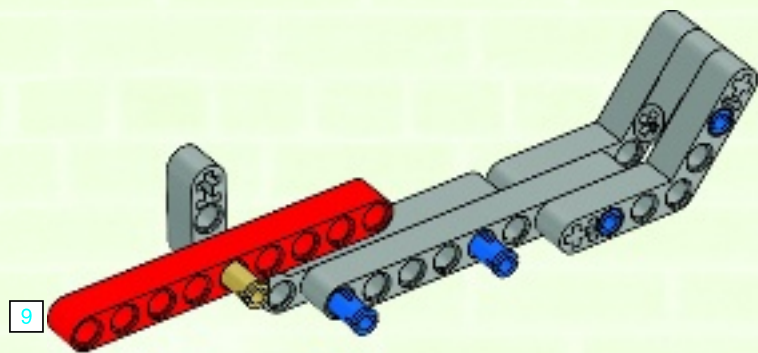

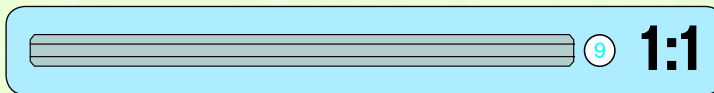
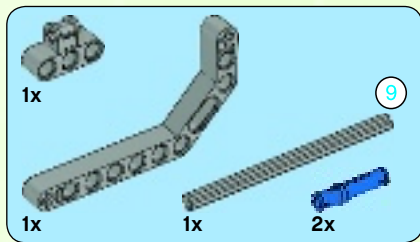

6

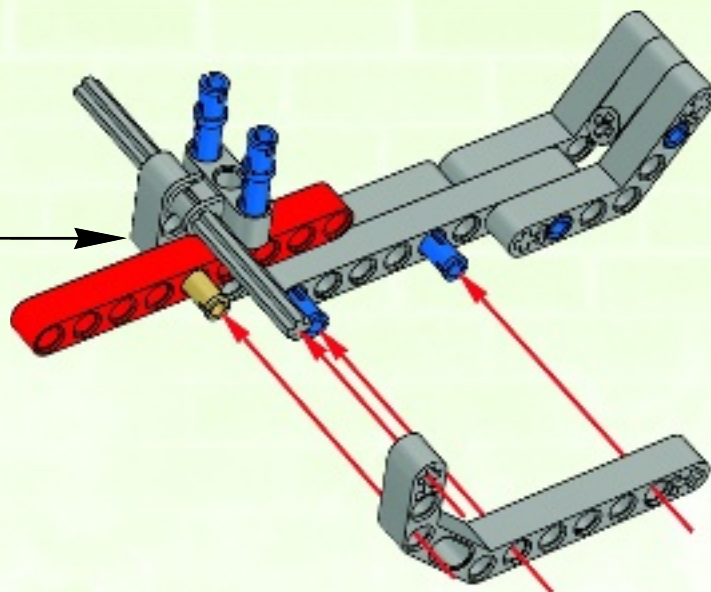
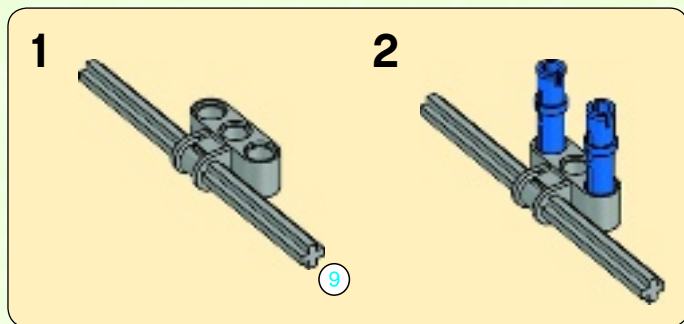

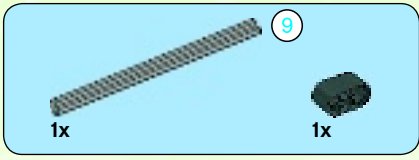

1

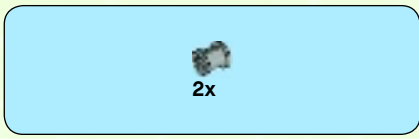
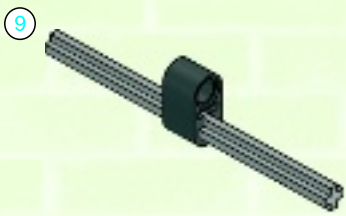

2

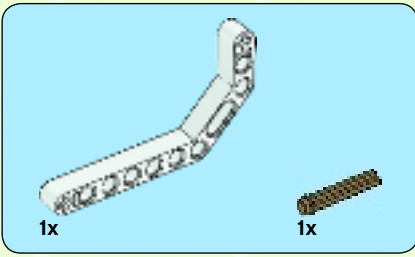
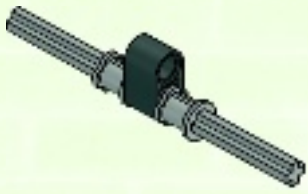

3

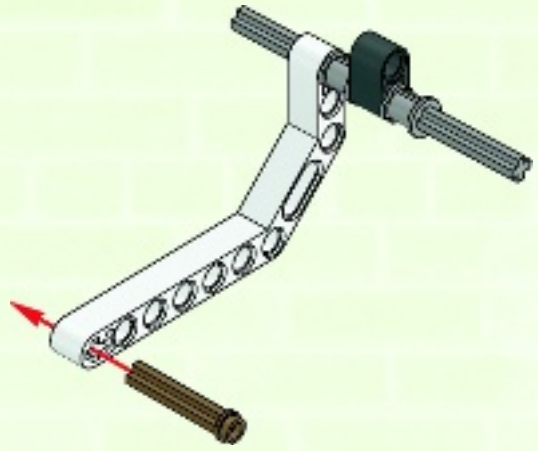



4

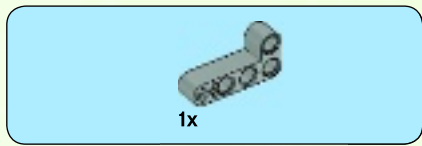
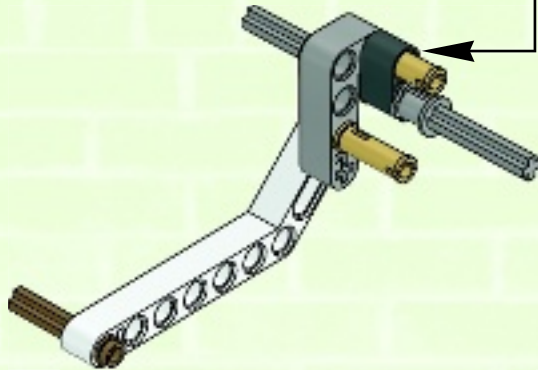
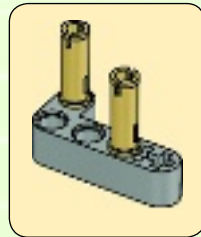

7

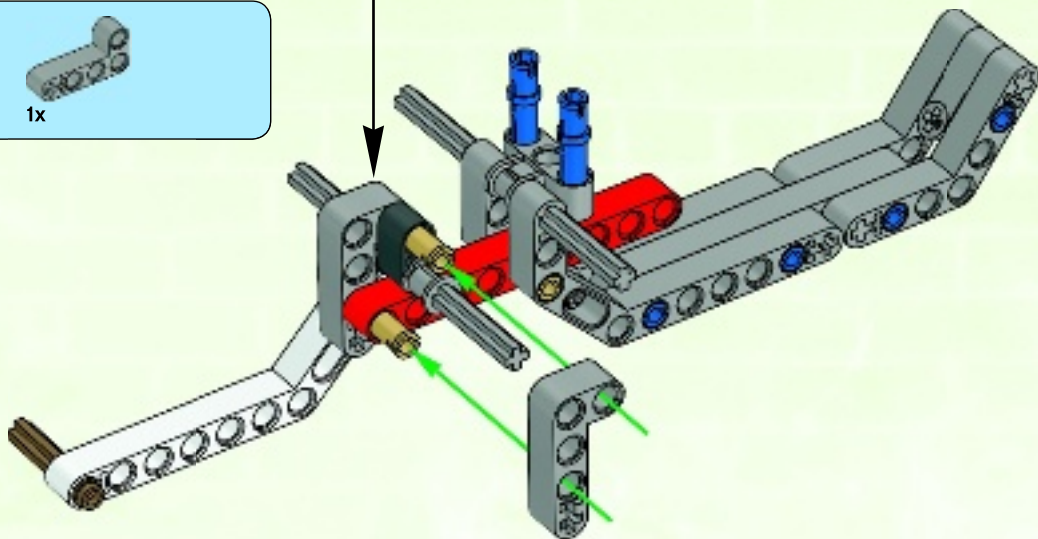

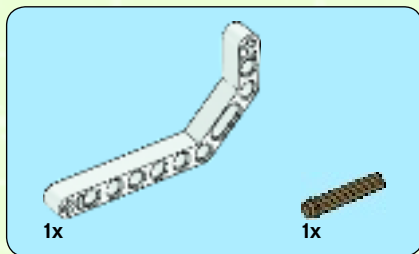

8

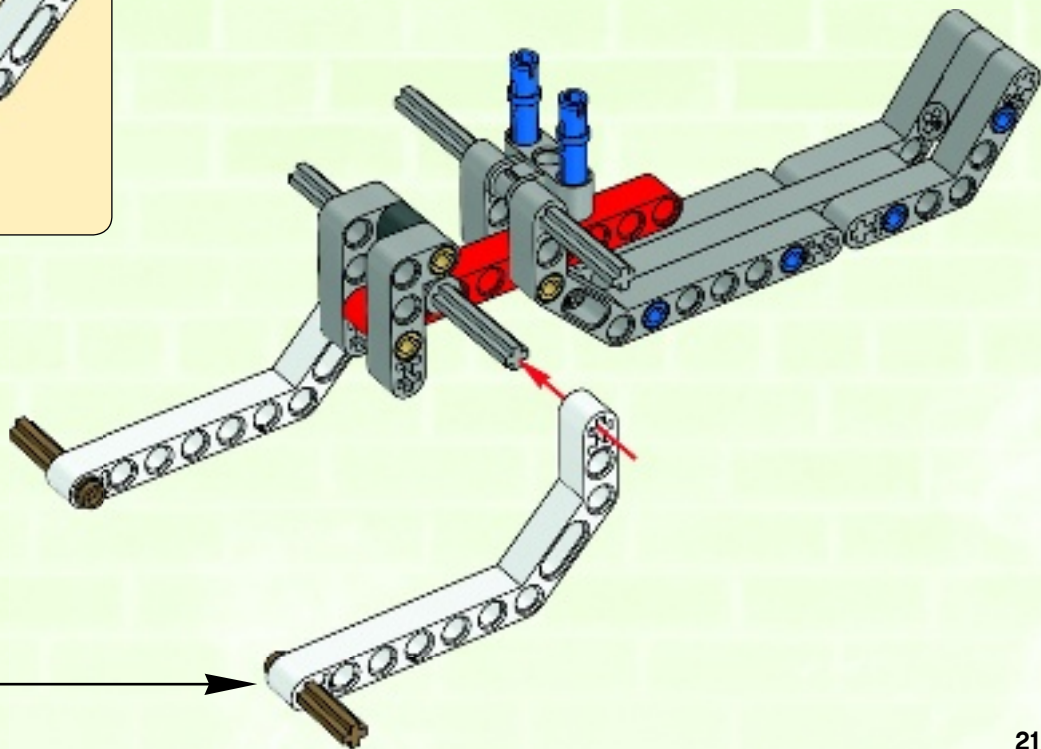
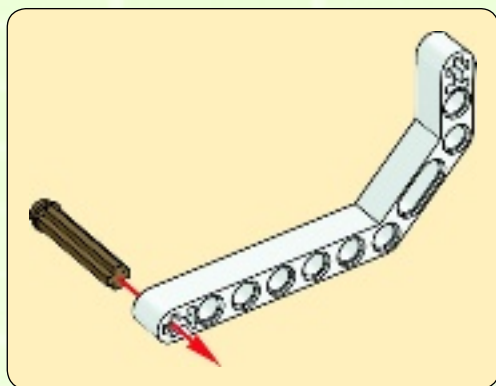

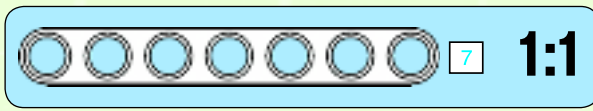
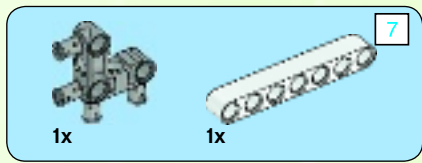

1

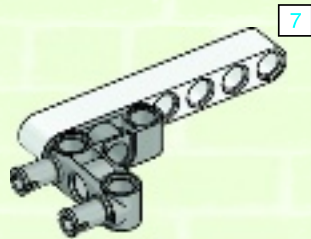

2

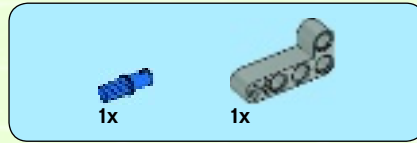
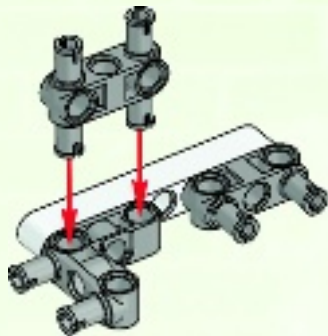

3

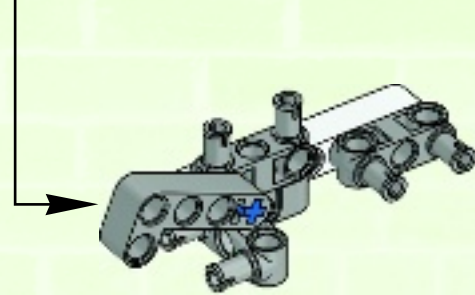
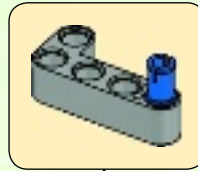

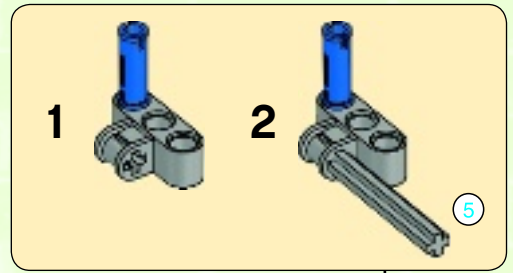
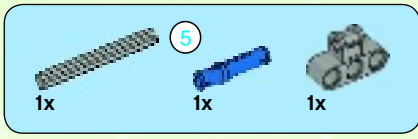

4

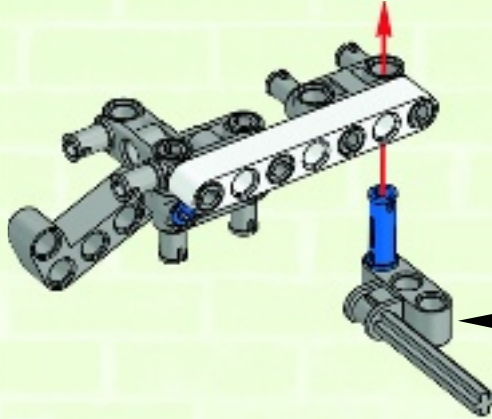
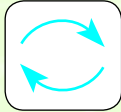

9

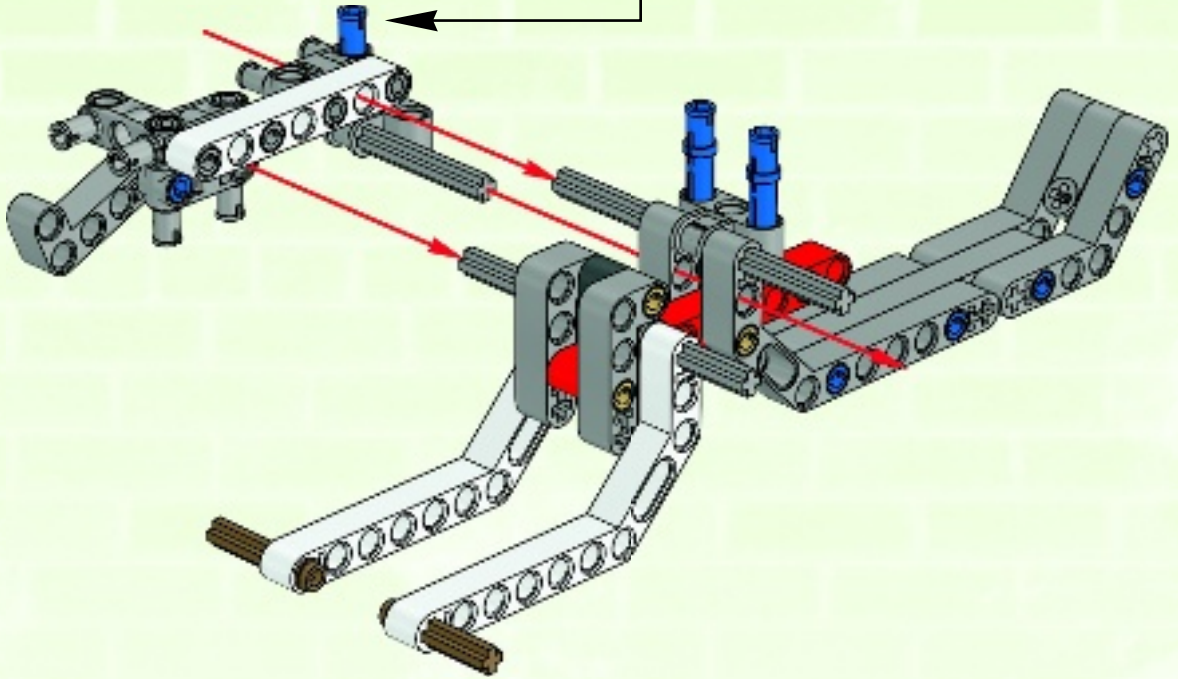

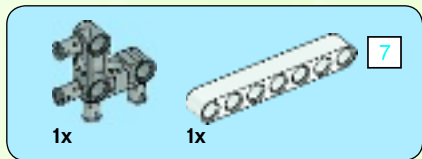

1

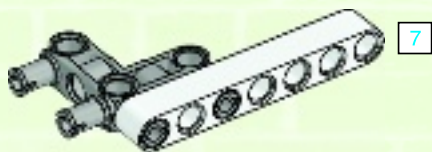

2

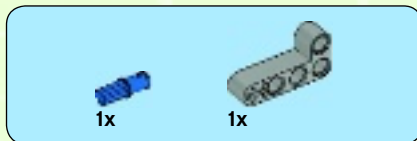
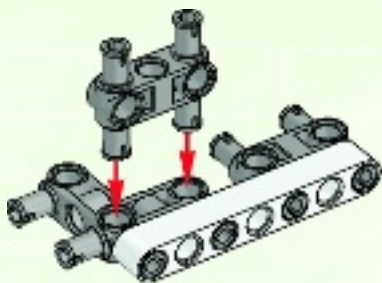

3

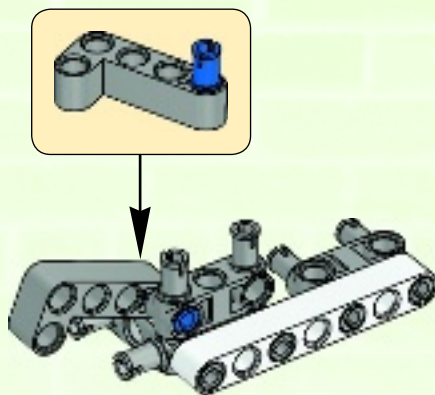



4

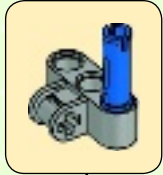
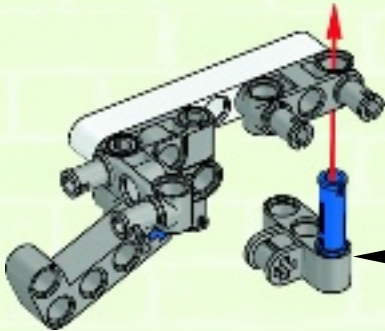
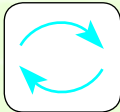

10

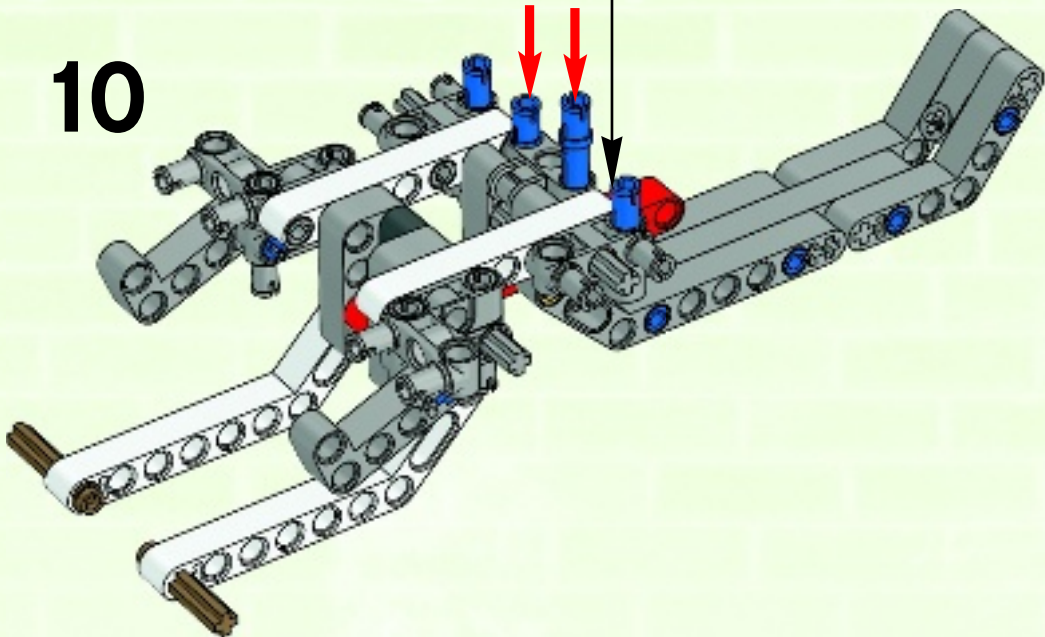

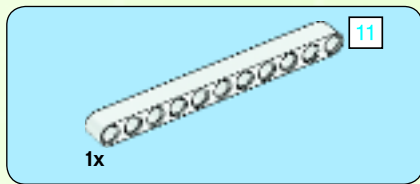

11

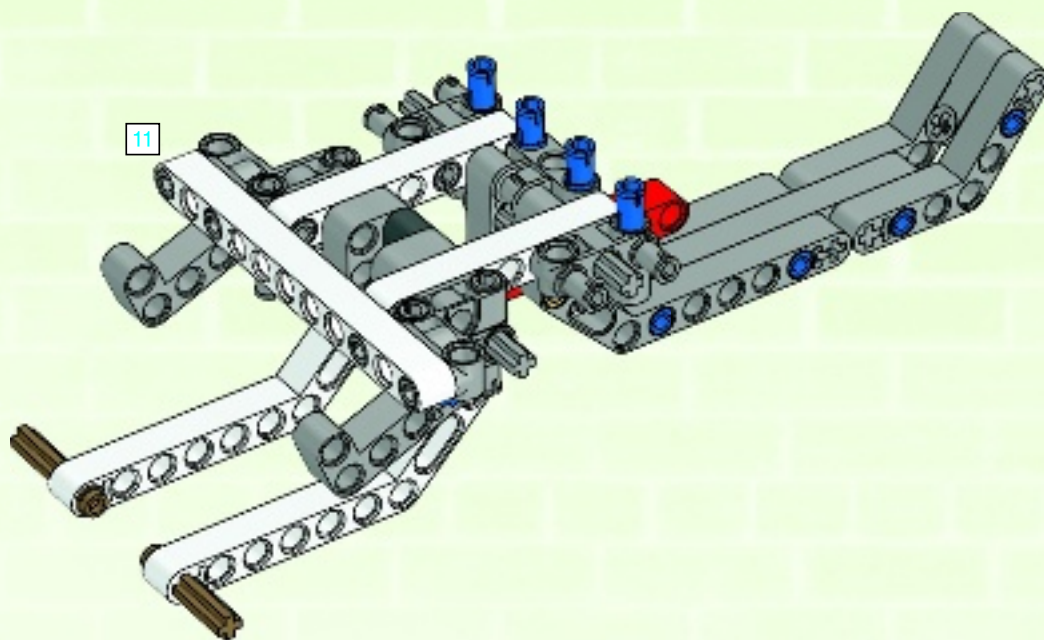



2x

12

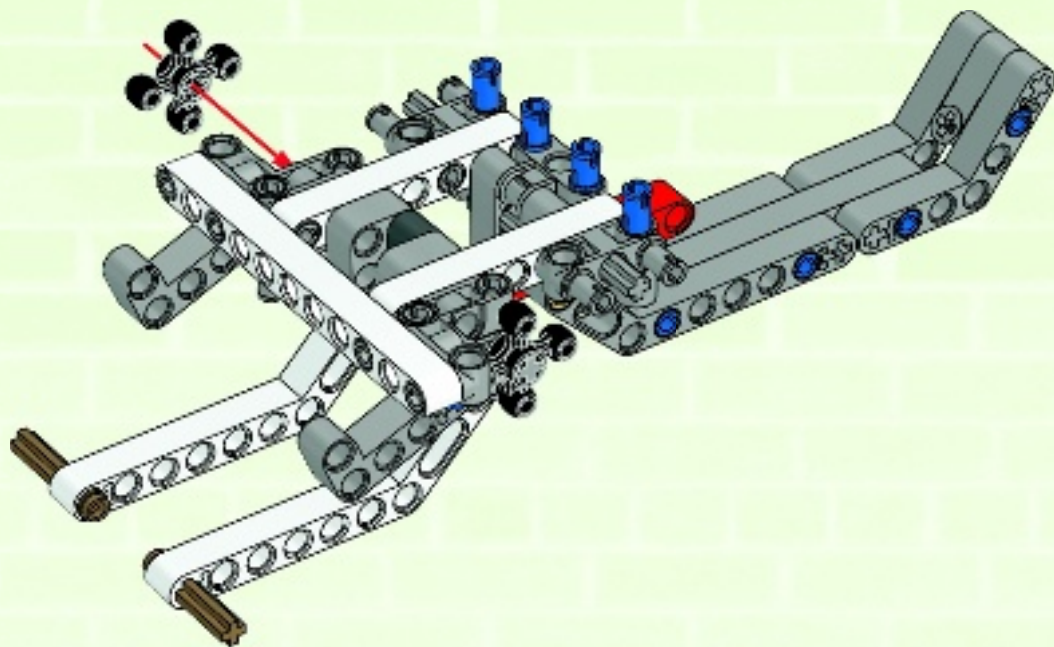

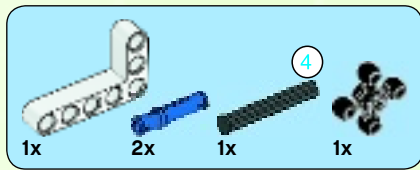

13

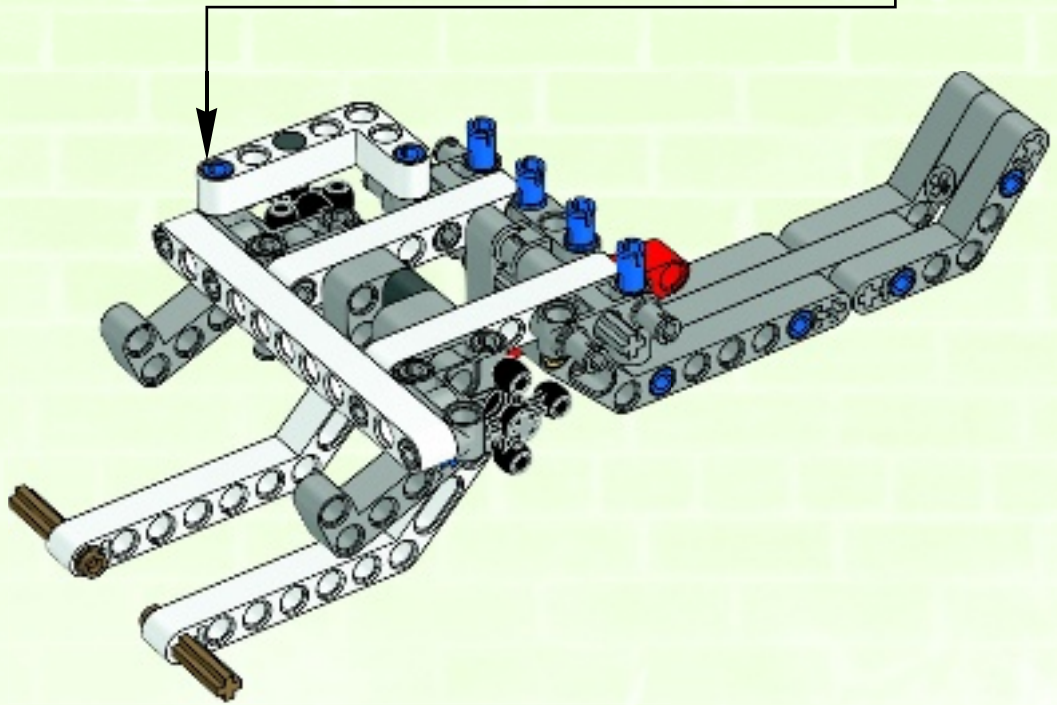
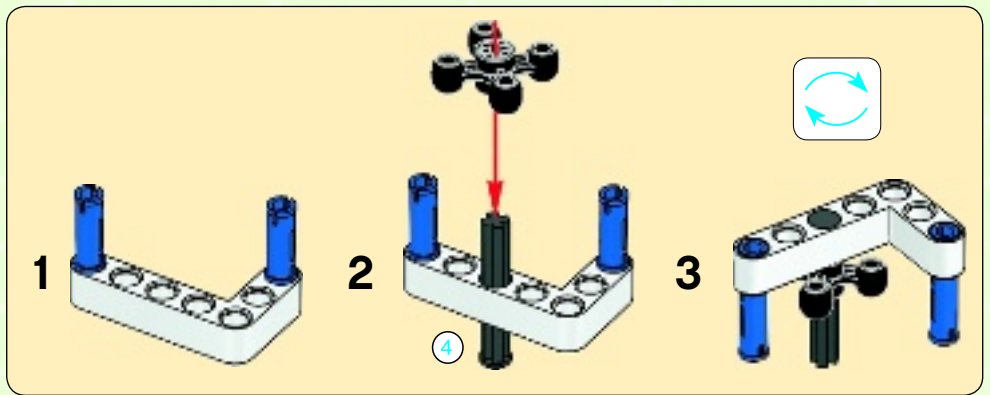

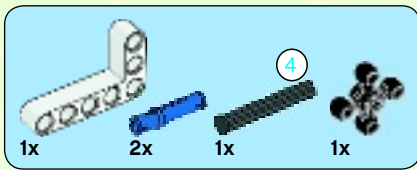

14

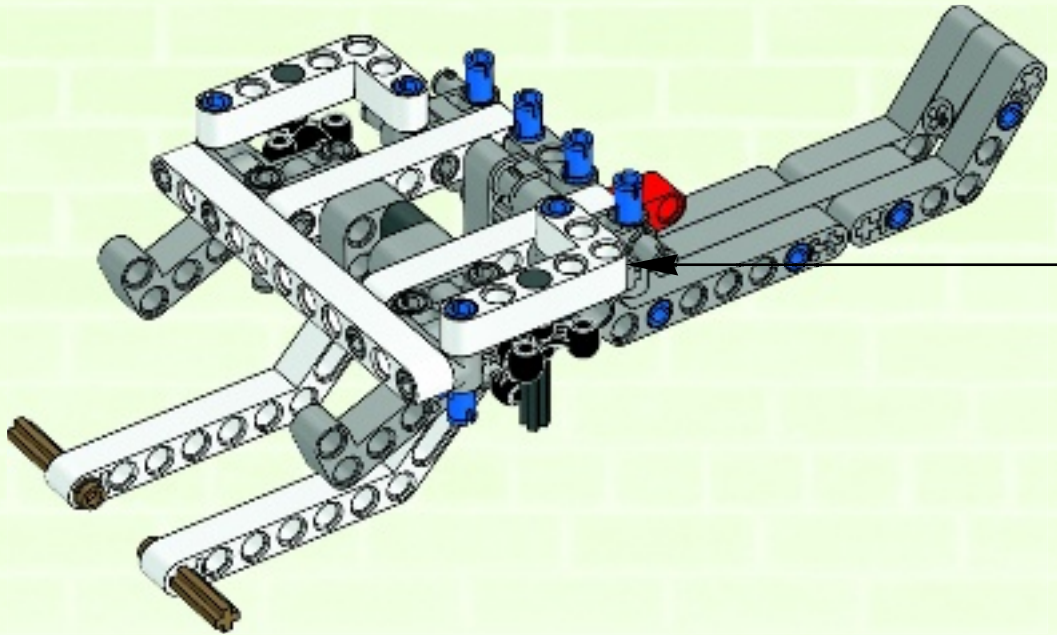
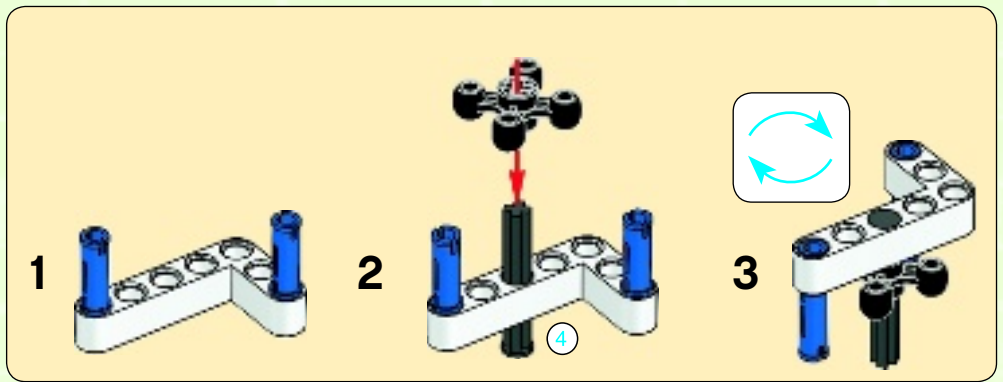

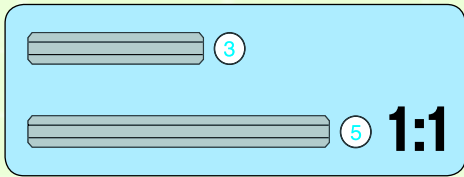

1

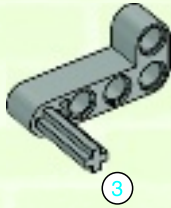

2

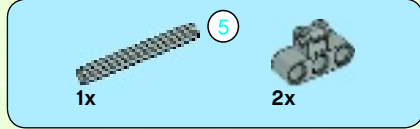
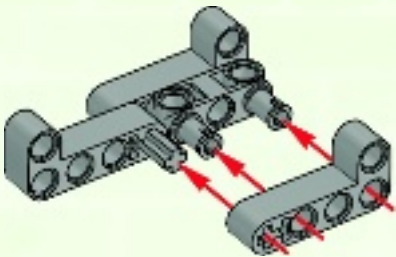

3

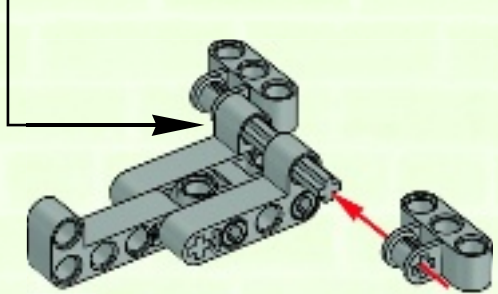
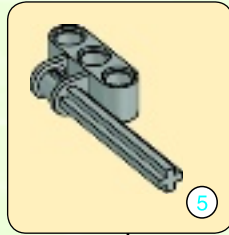

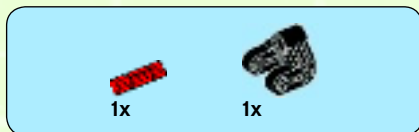

4

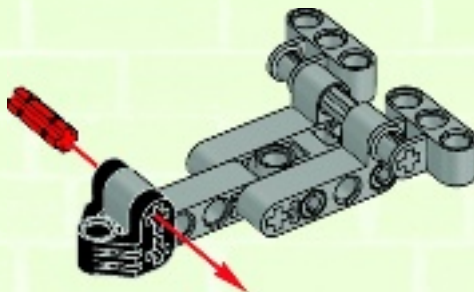

5

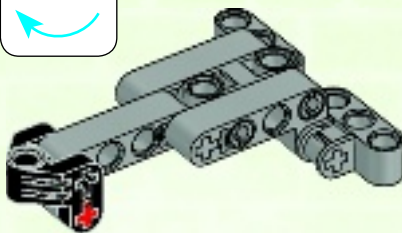
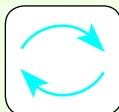

15

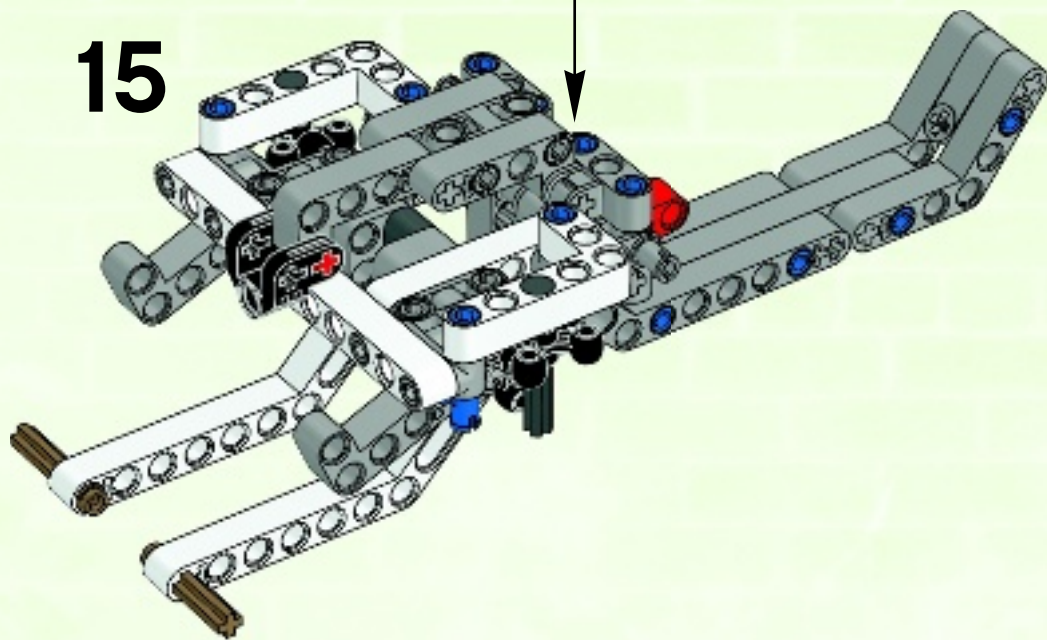

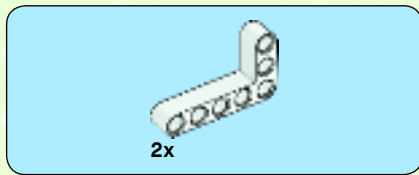

16

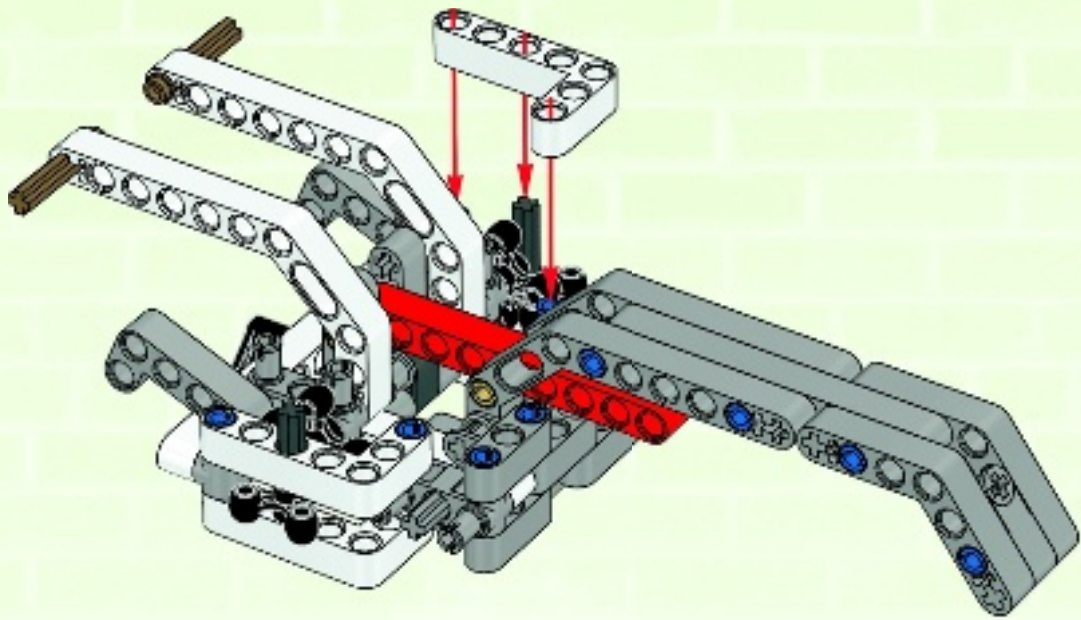
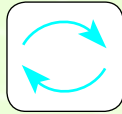



2x

17

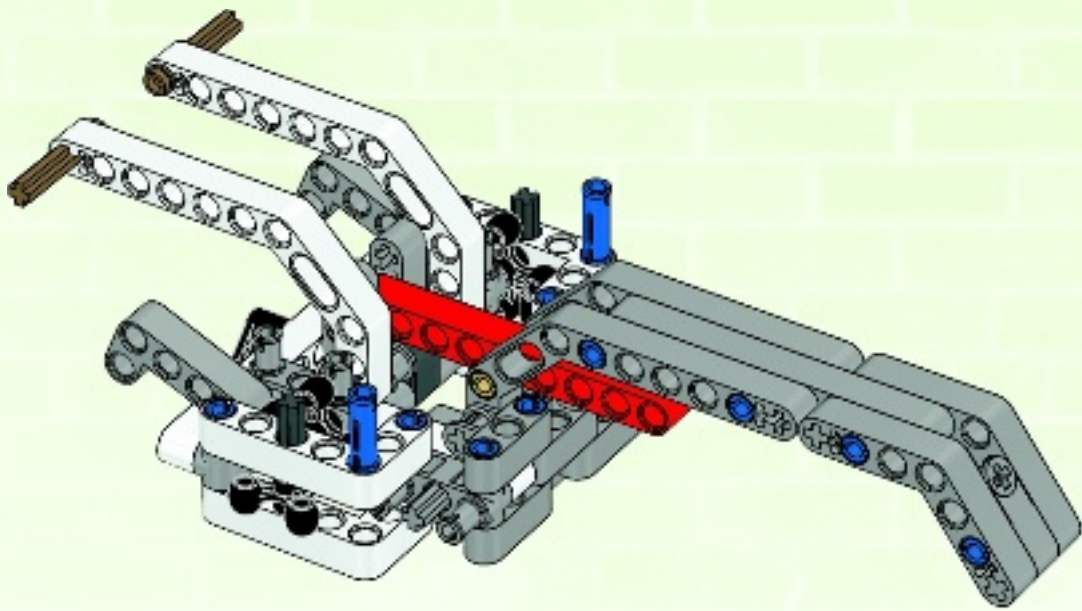

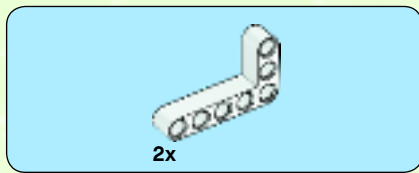

18

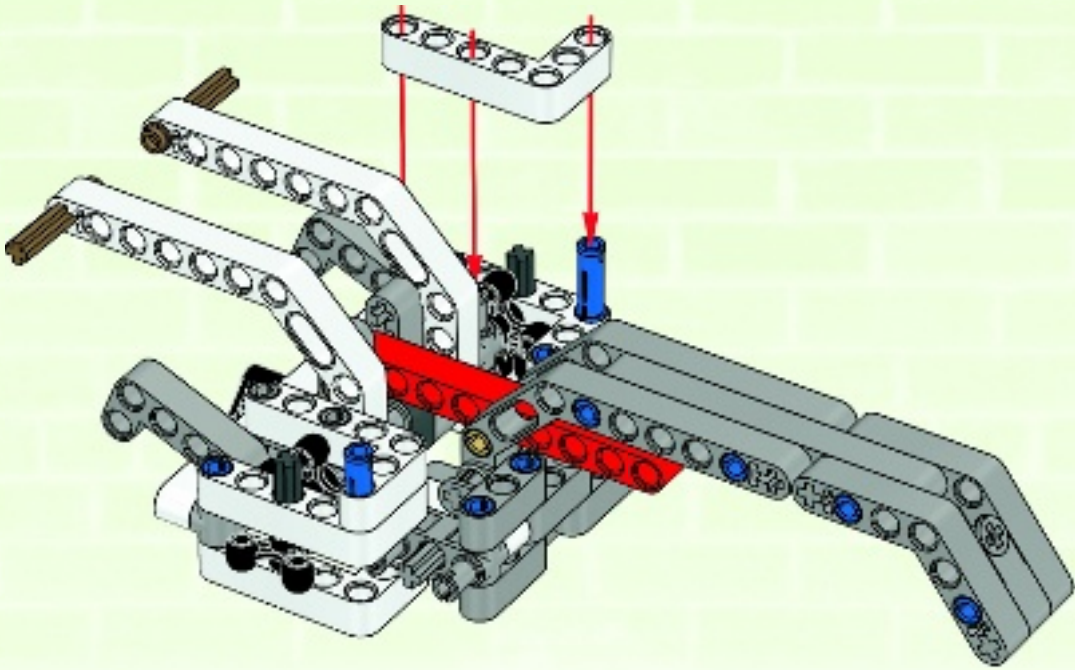



2x

19

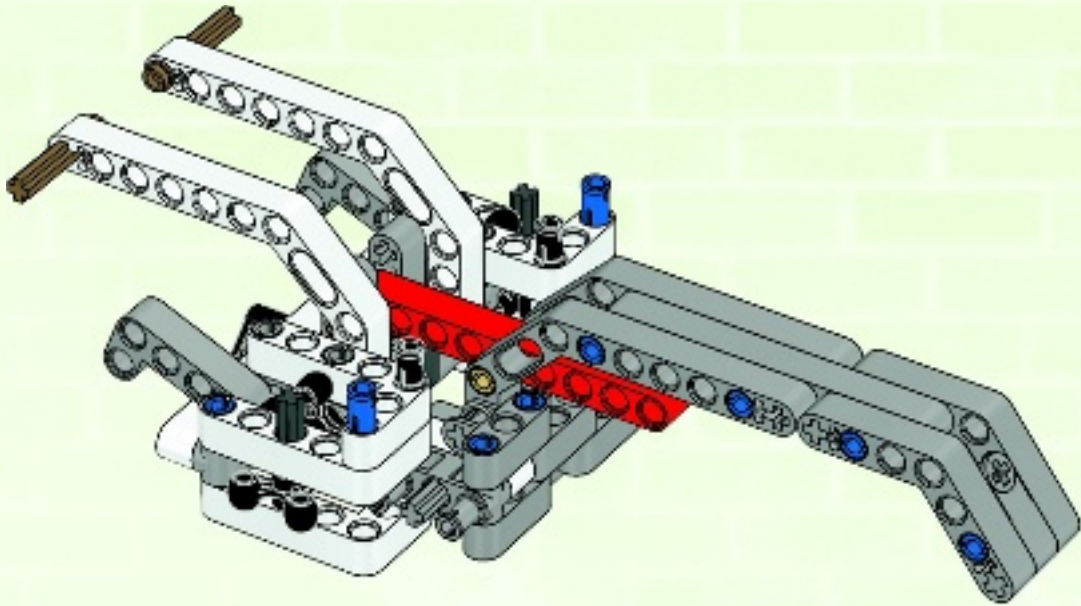

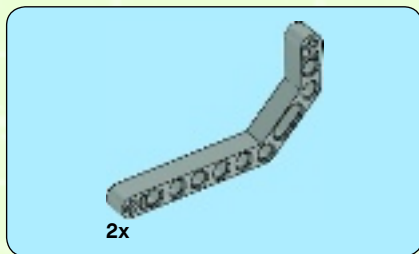

20

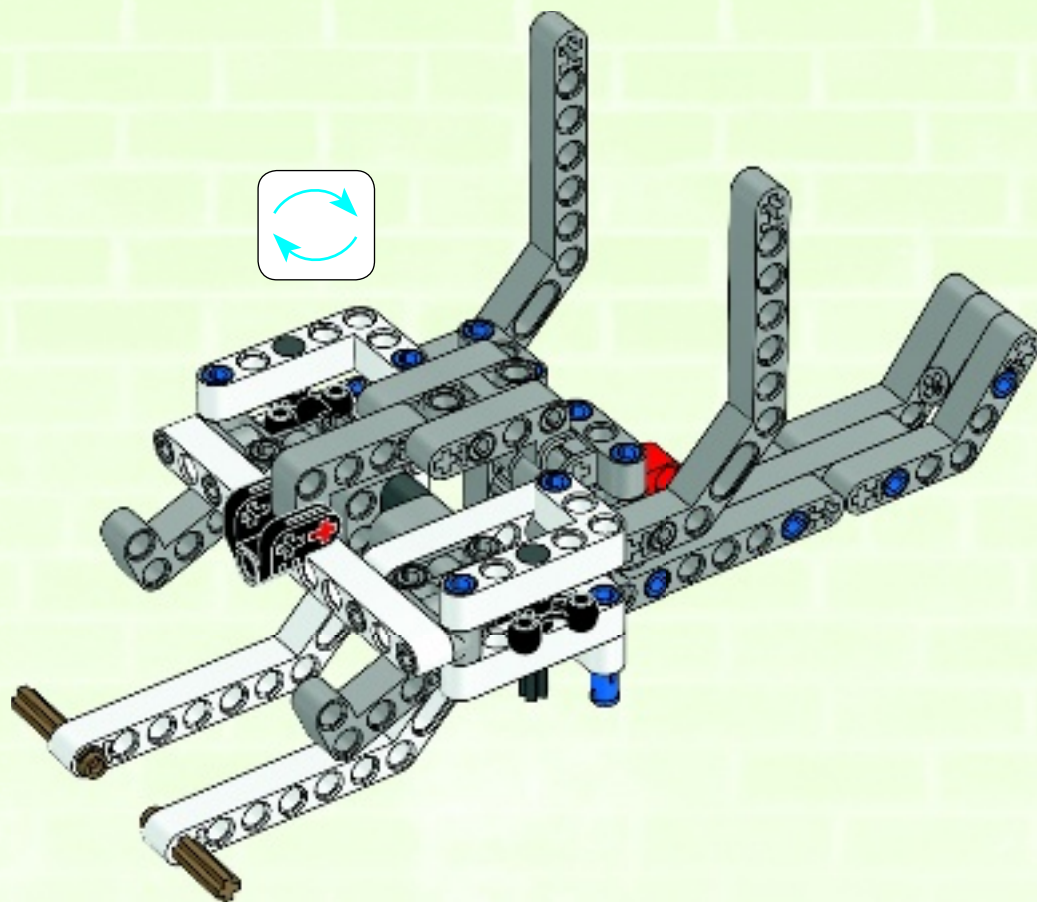

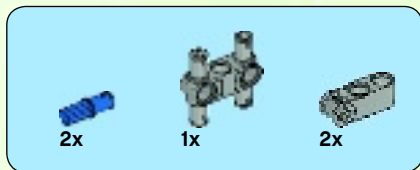

21

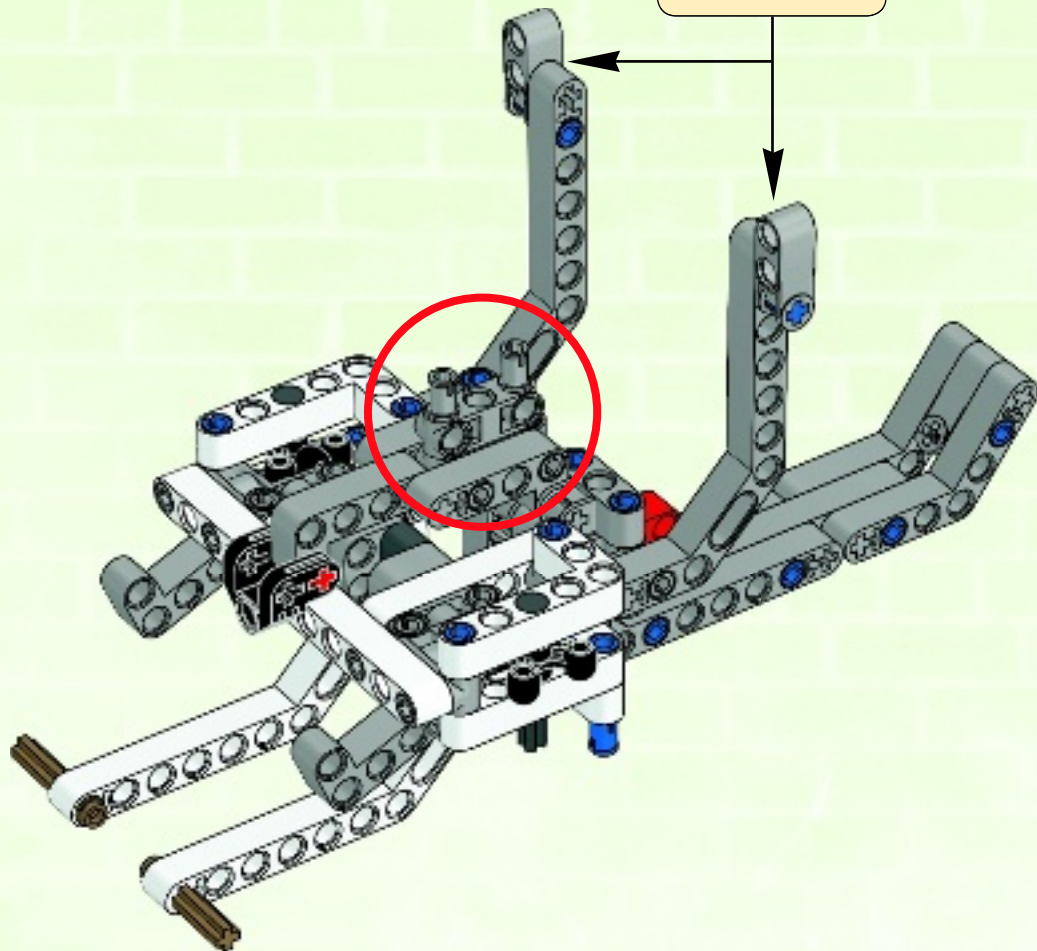

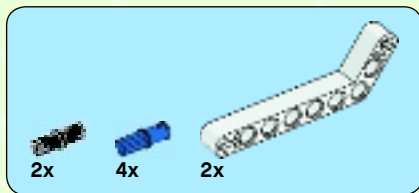

22

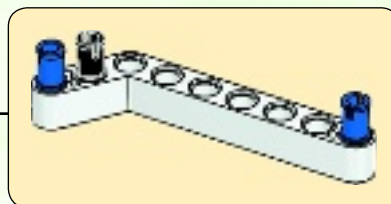
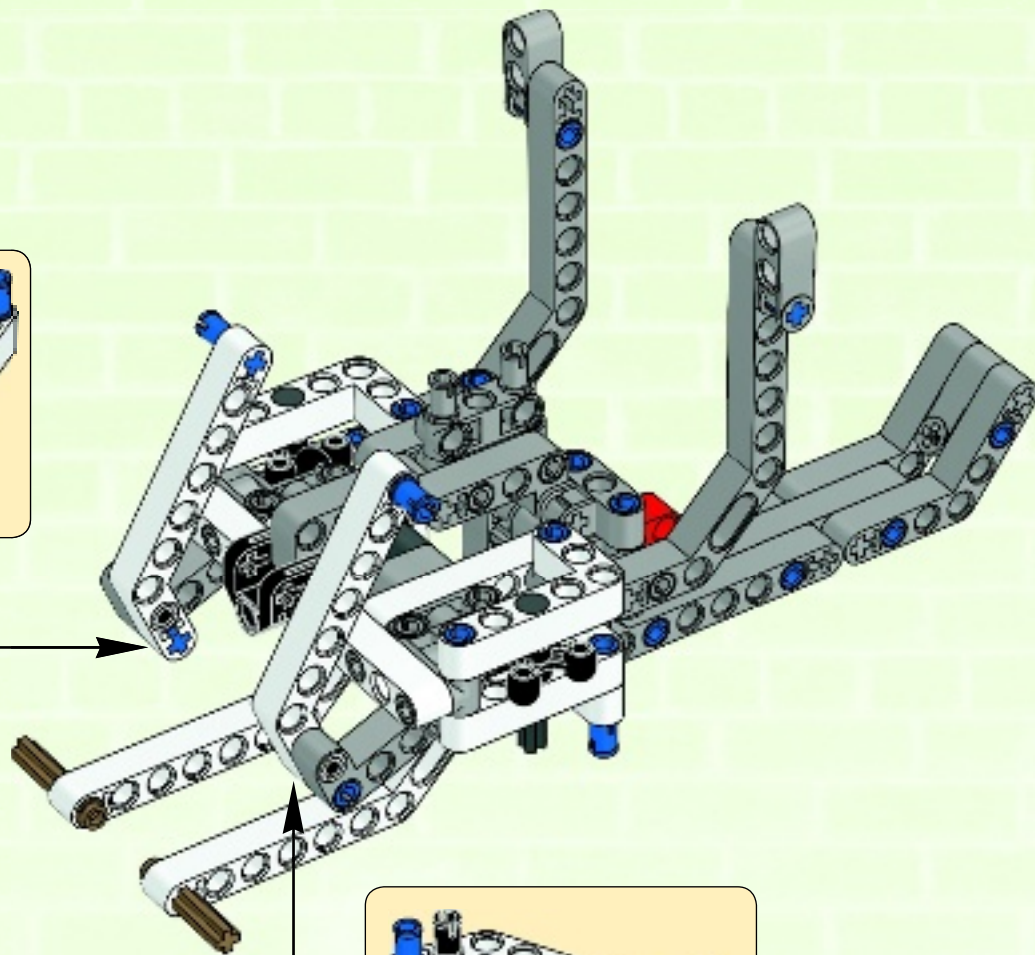
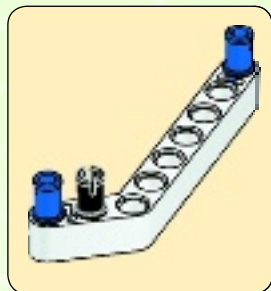

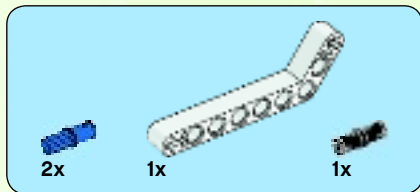

23

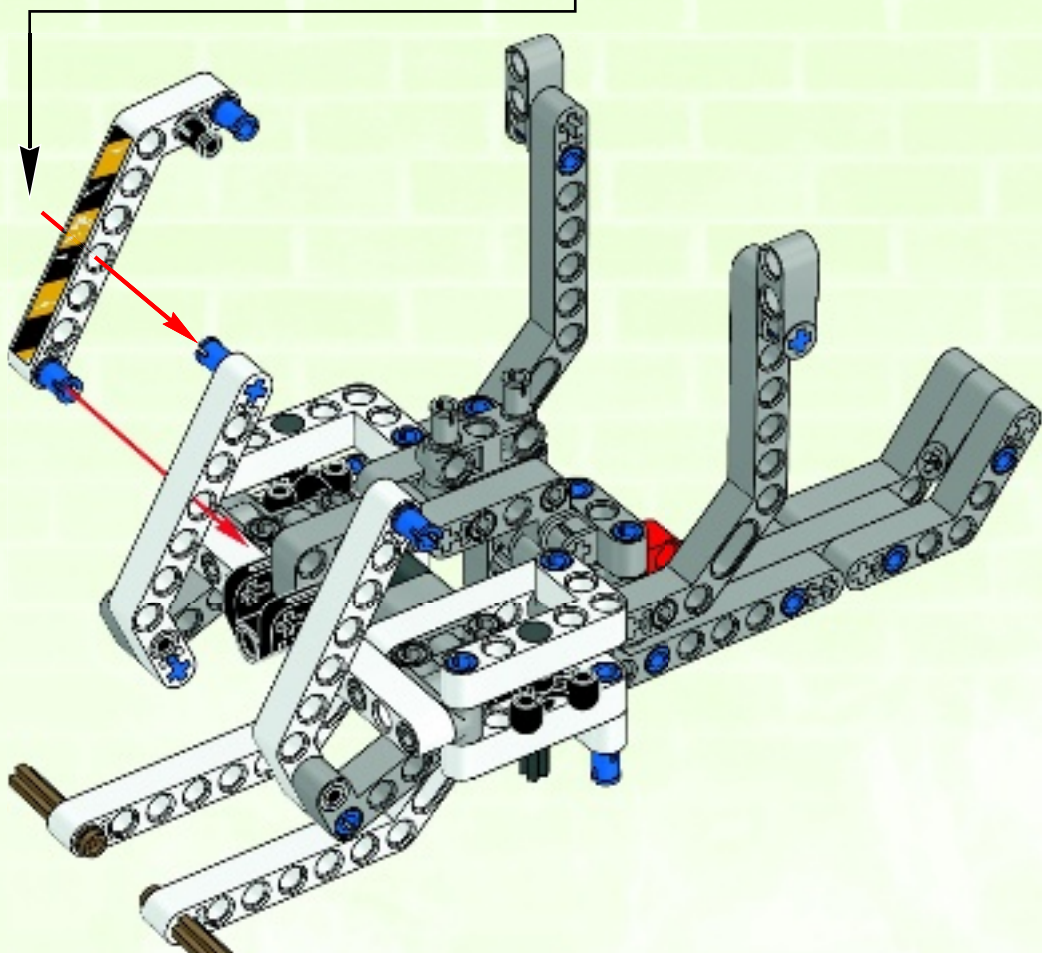
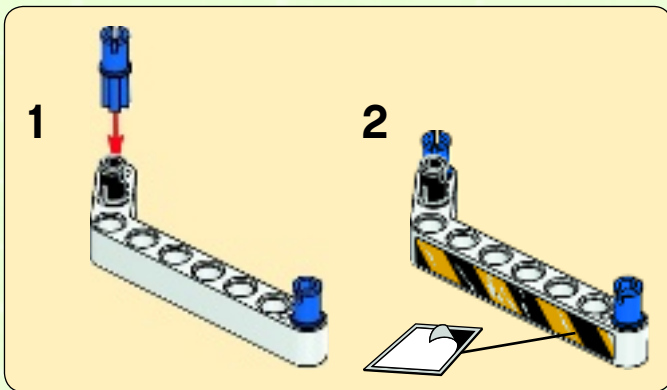

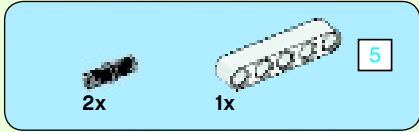
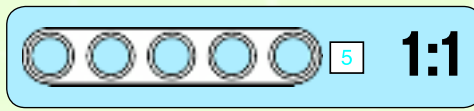
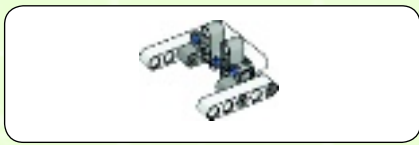

1

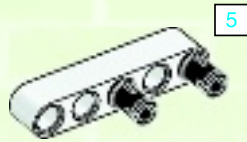

2

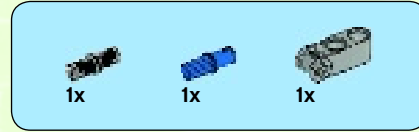
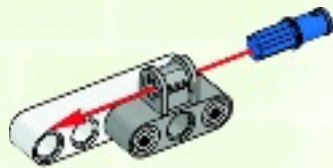

3

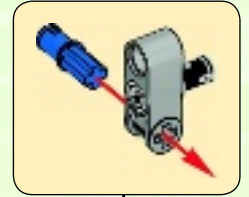
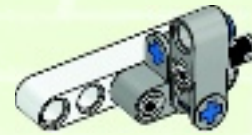

4

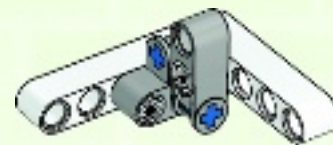
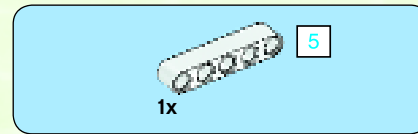

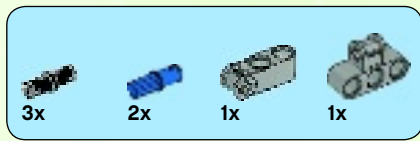

5

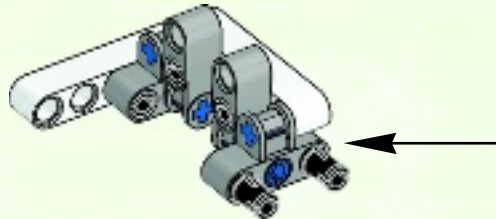
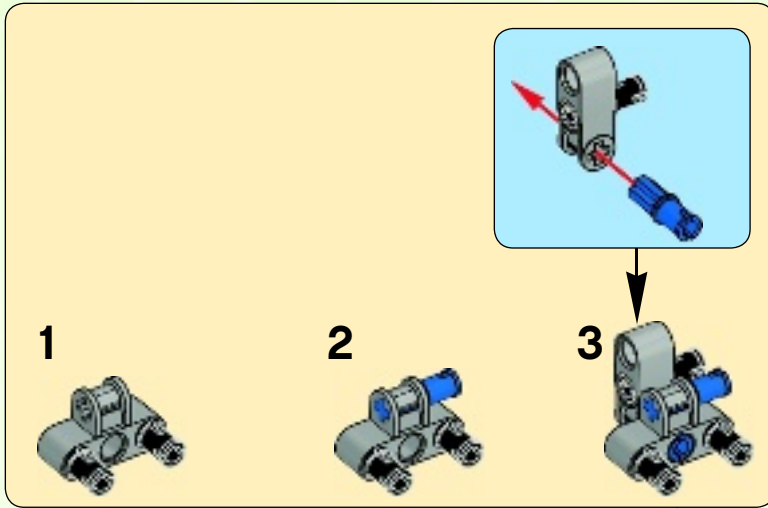

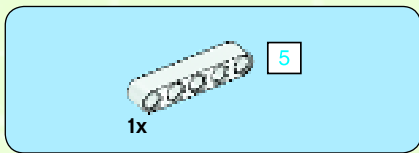

6

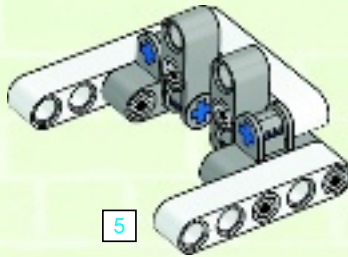

24

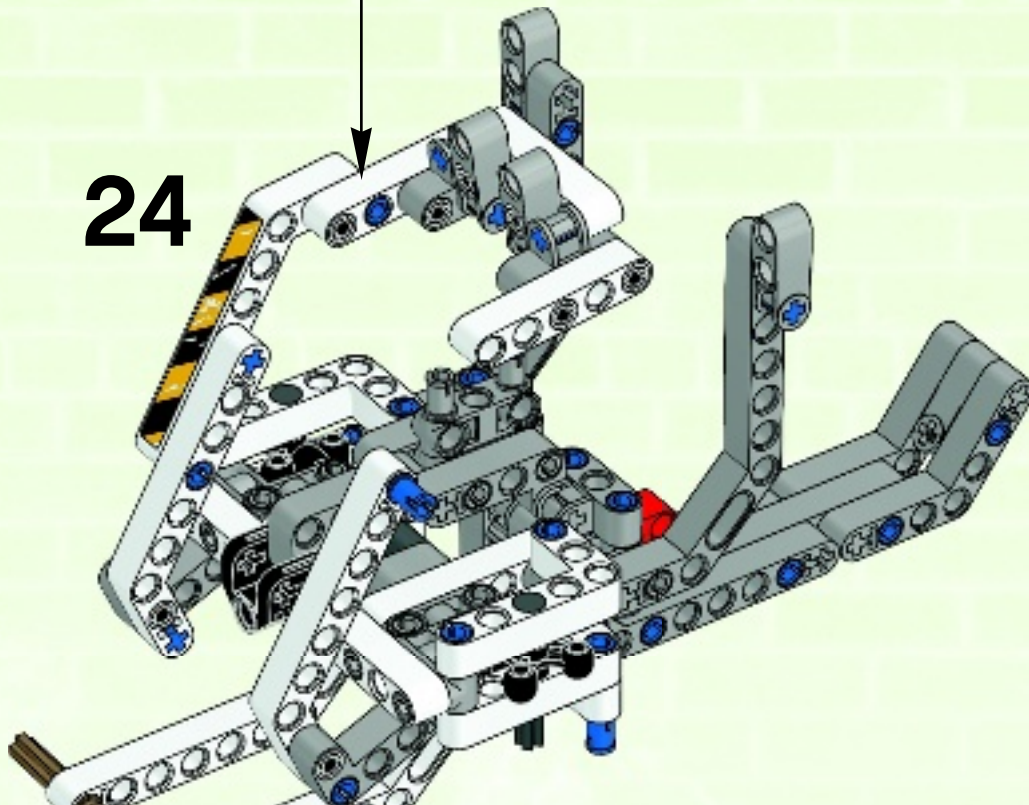

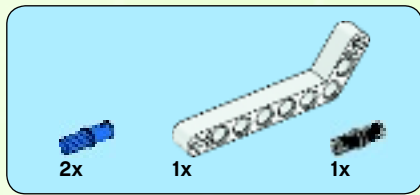

25

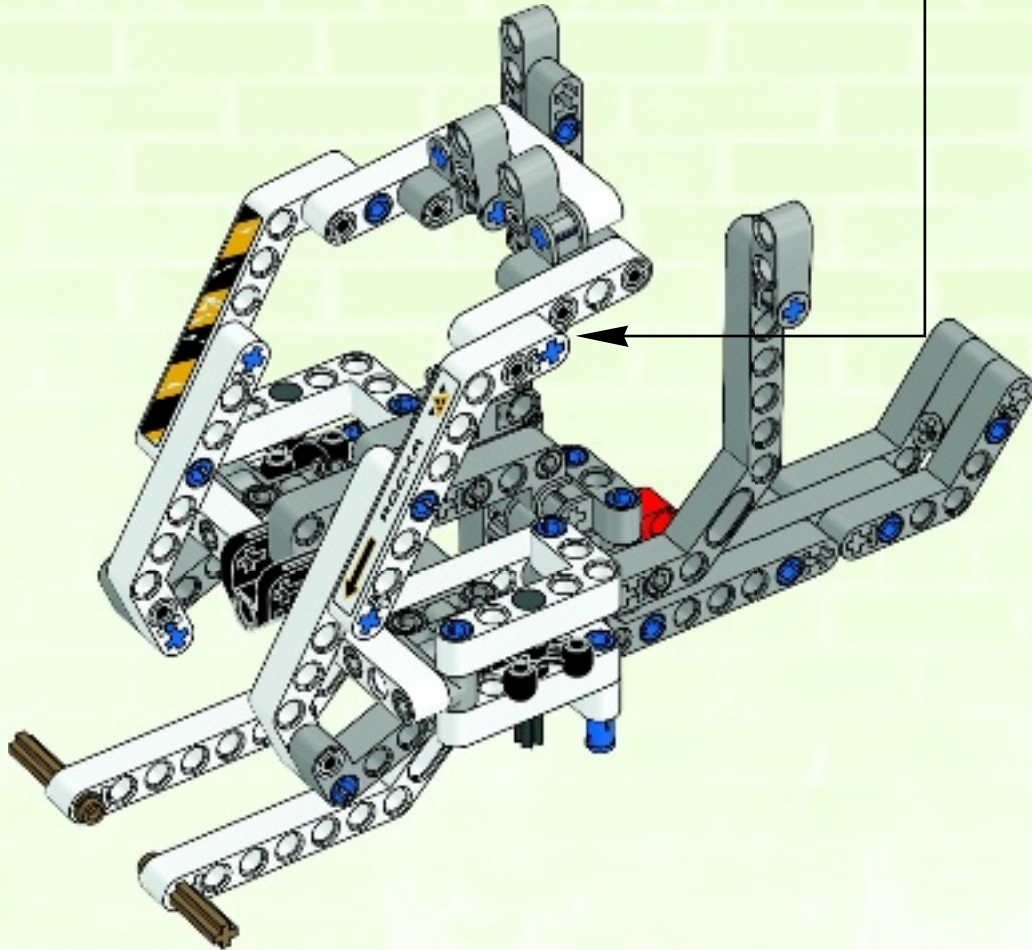
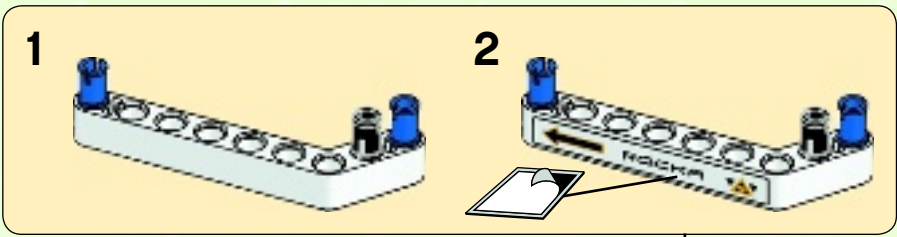

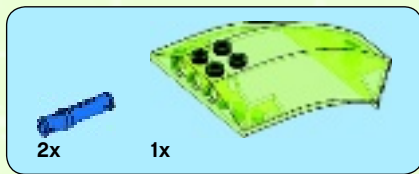

1

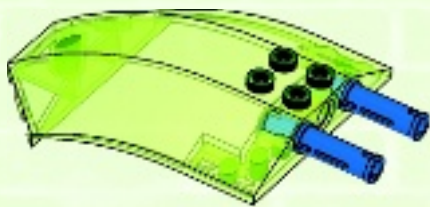

2

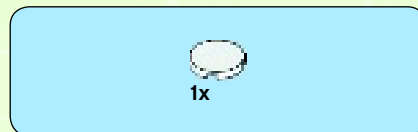
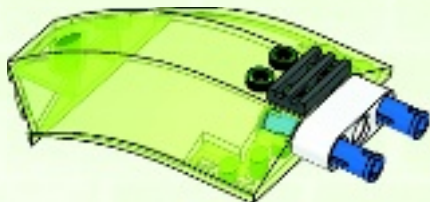

3

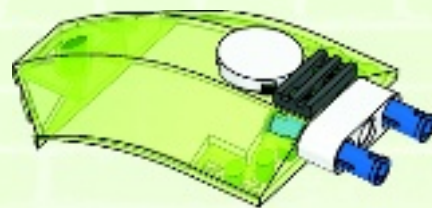

4

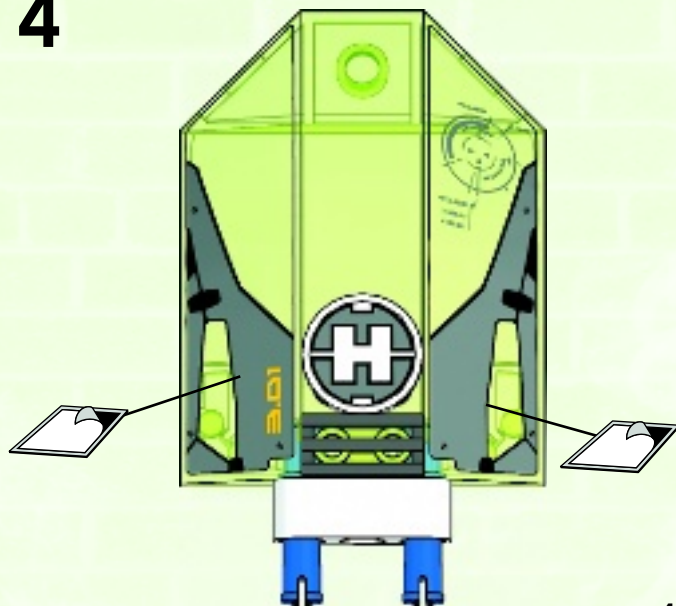

26

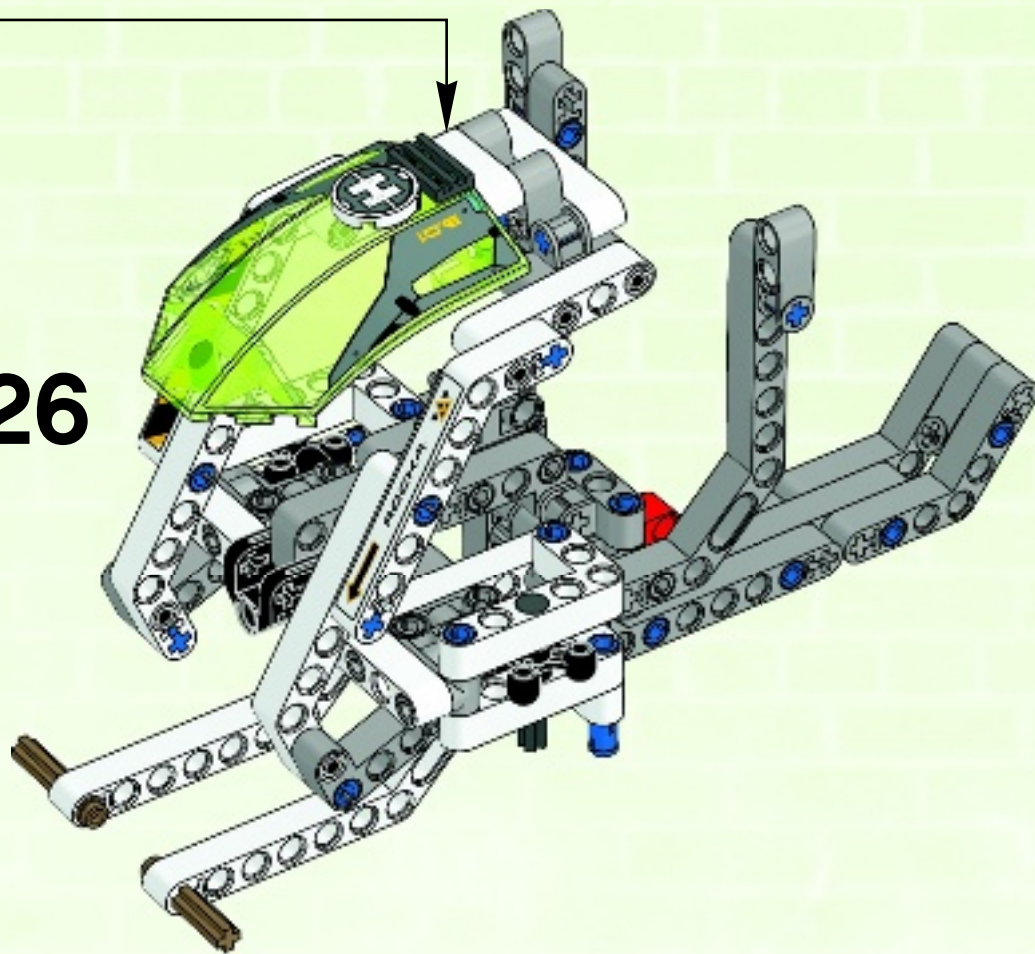

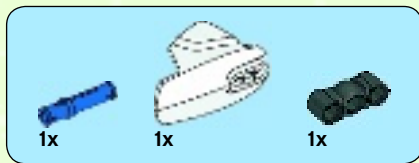

27

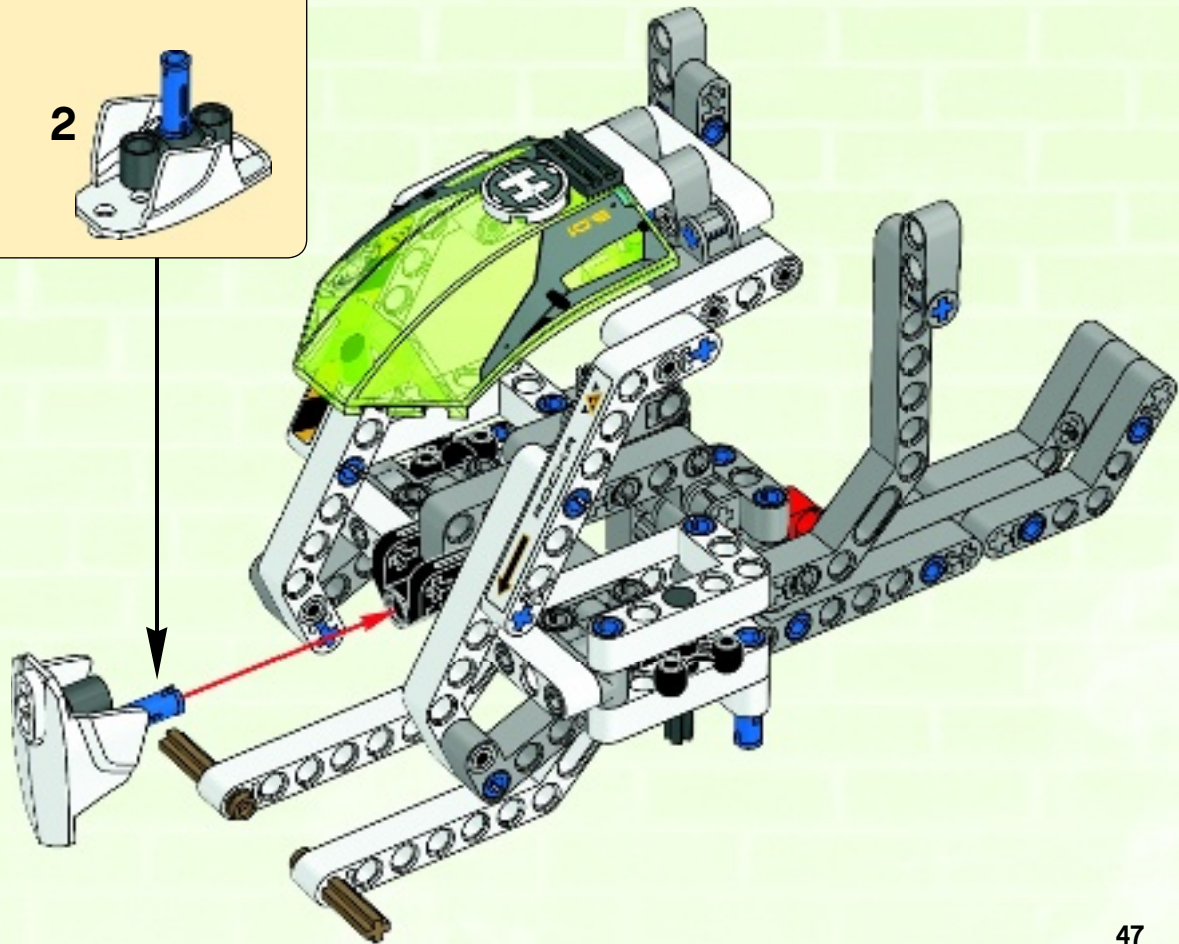
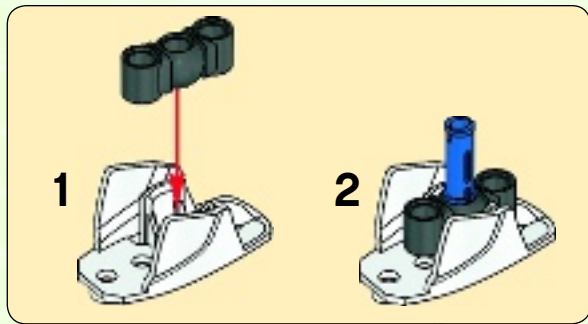

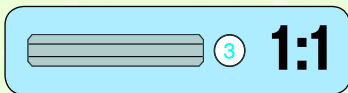
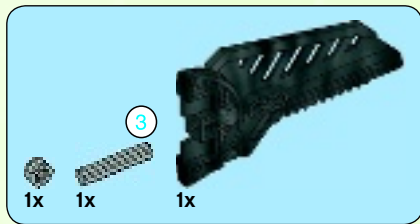

28

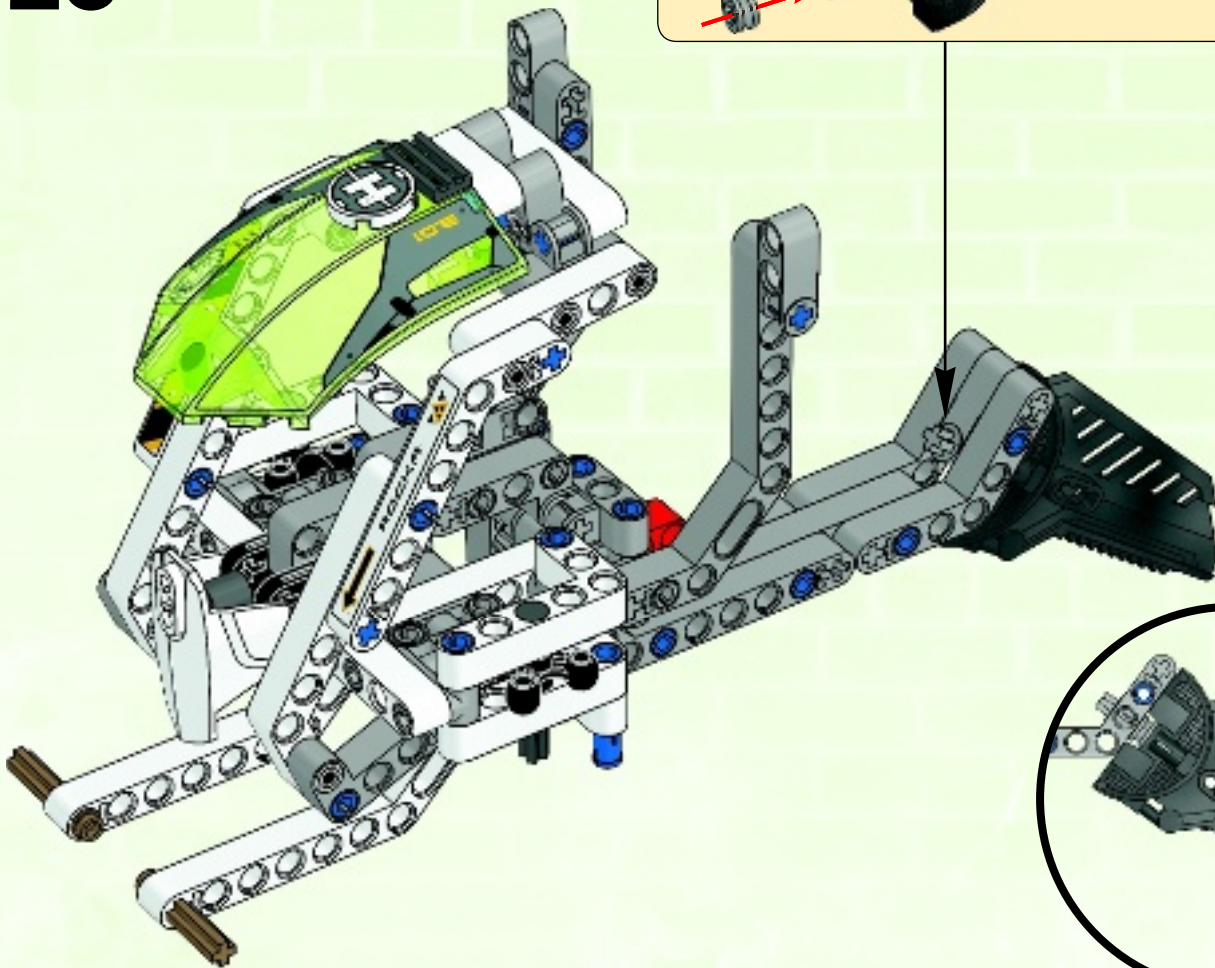

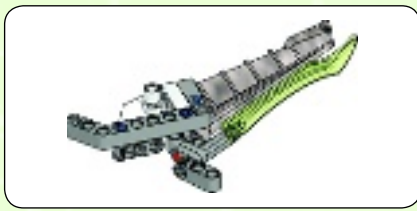

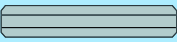
 3 **1:1**

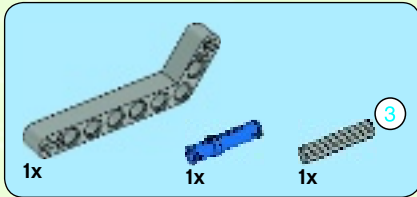

1

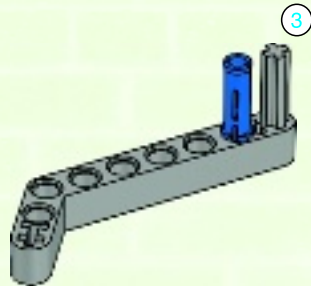

2

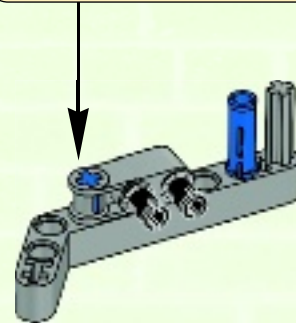
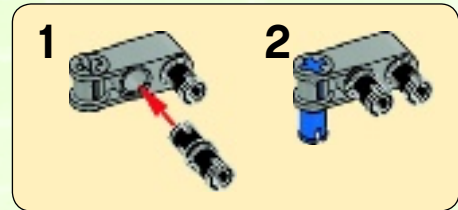

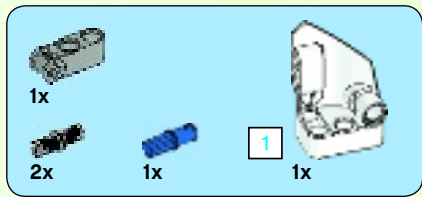

3

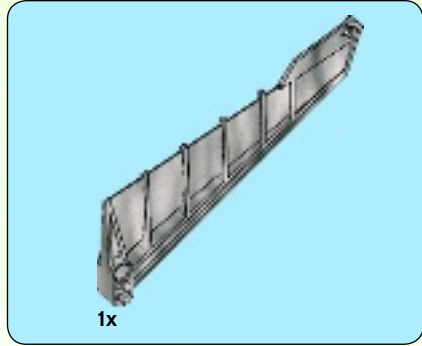
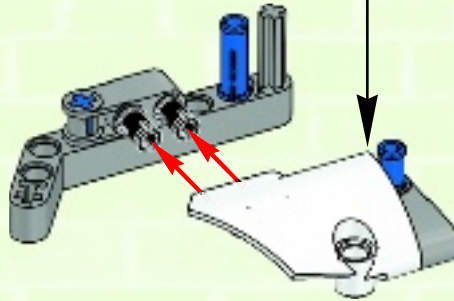
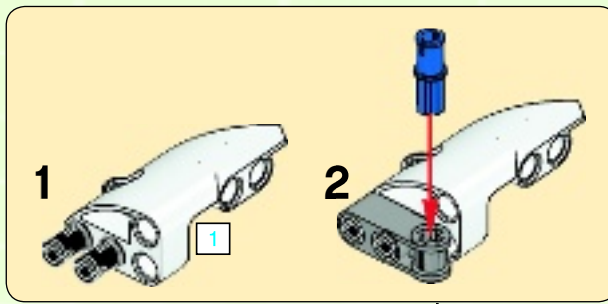

4

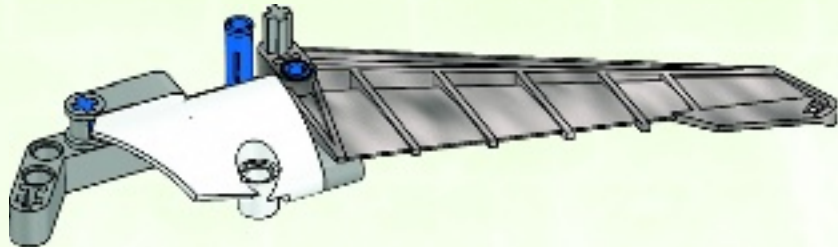

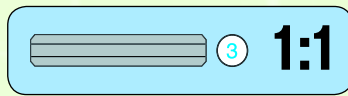
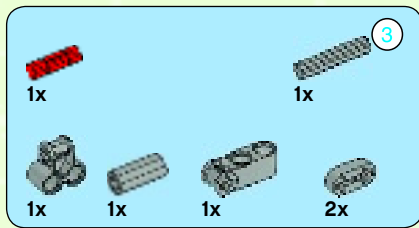

5

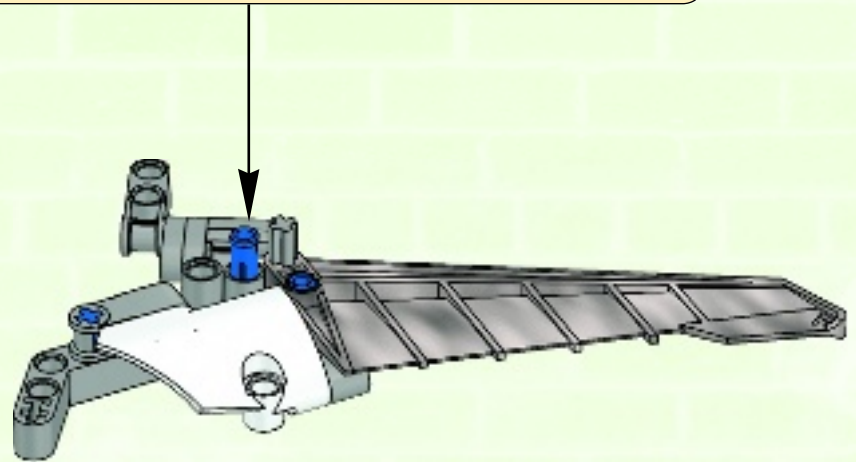
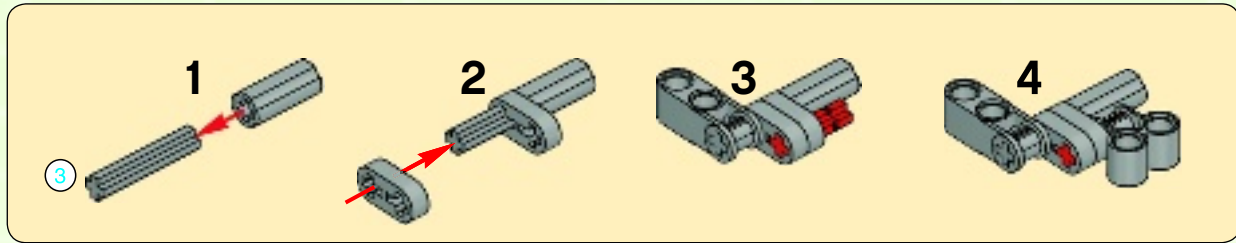



6

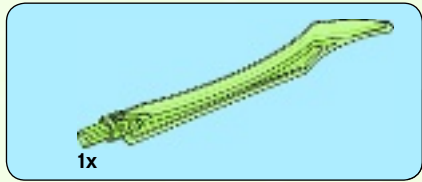
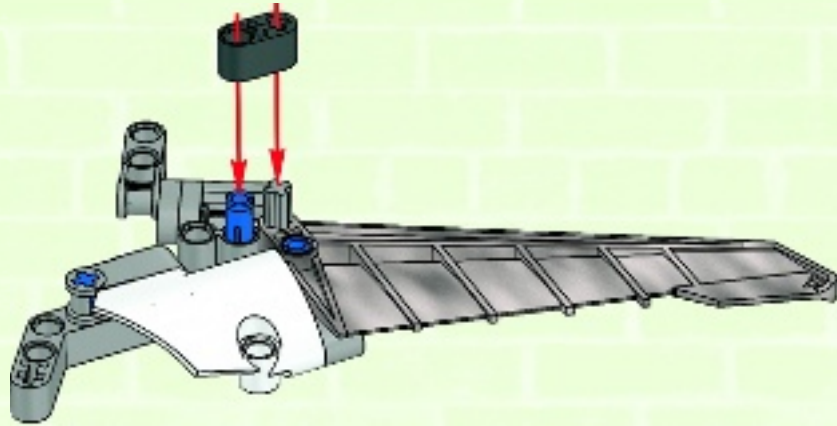

7

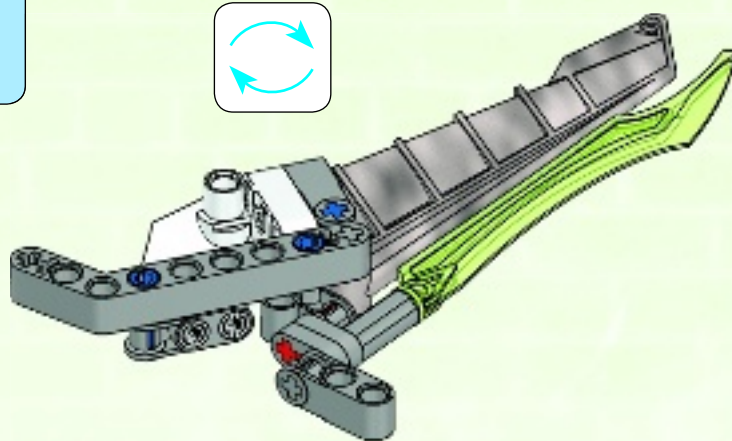

29

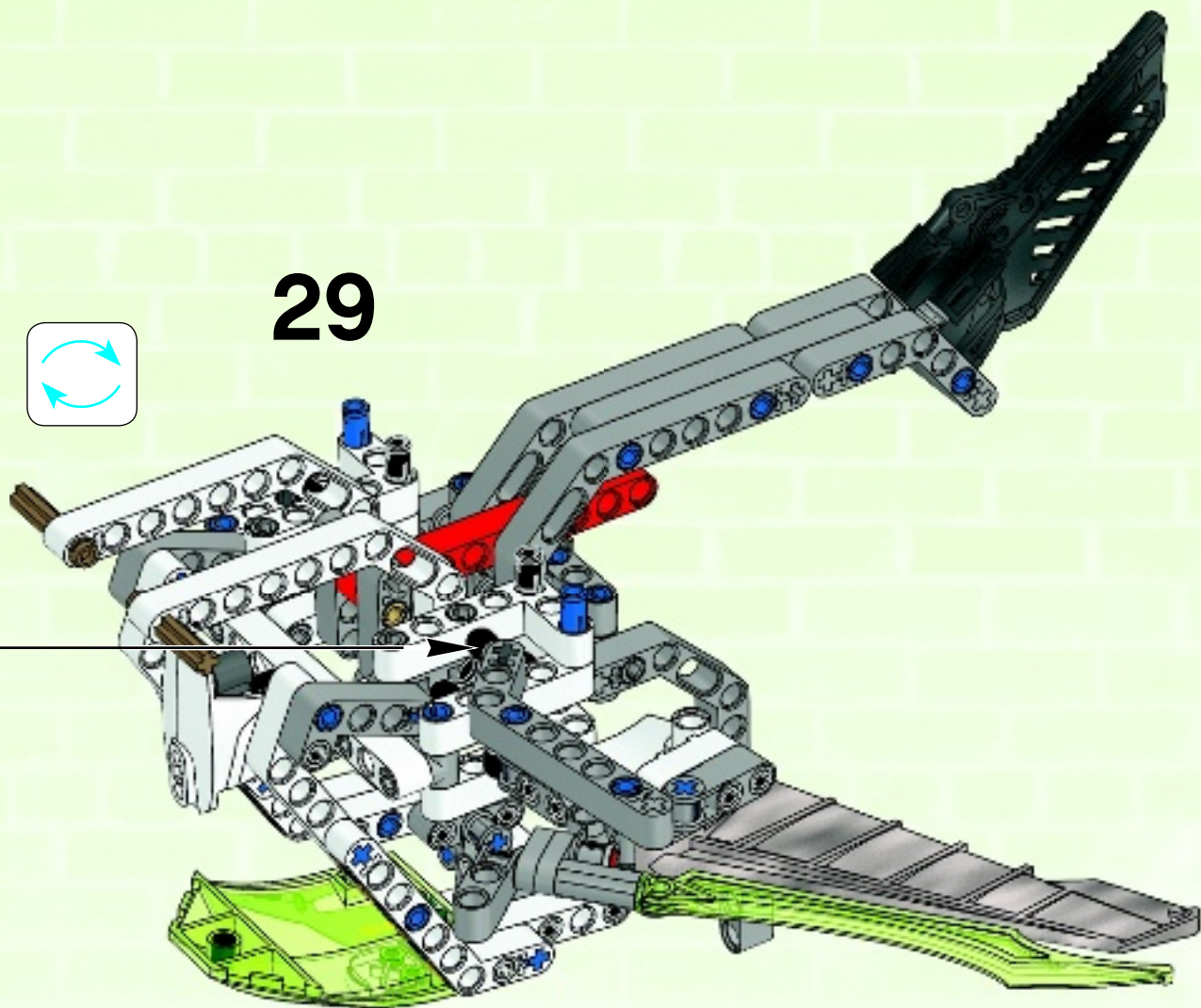
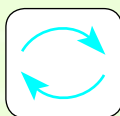

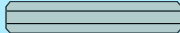

 ③ **1:1**

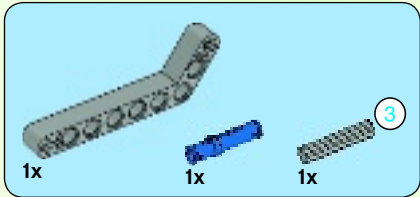

1

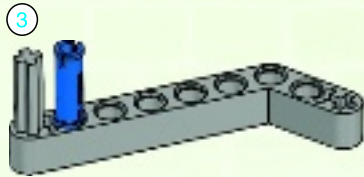

2

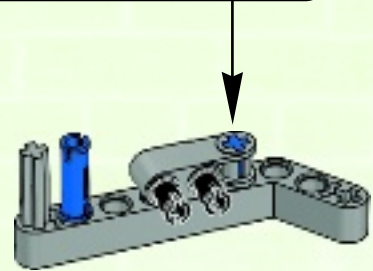

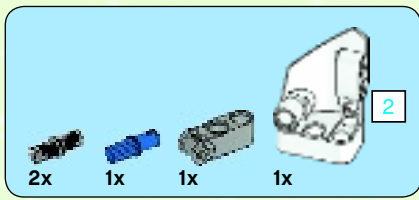

3

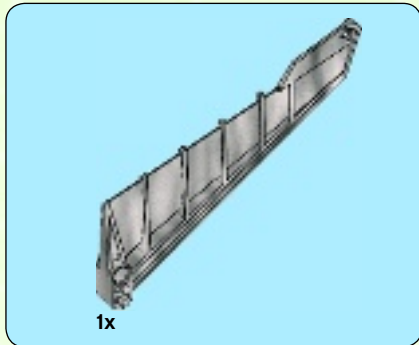
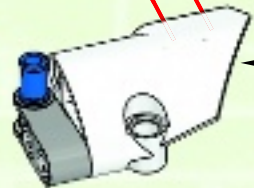
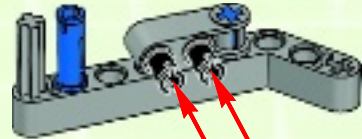
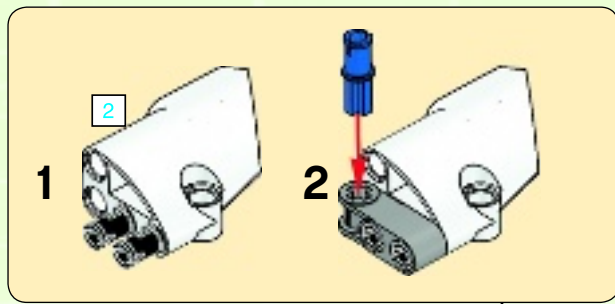

4

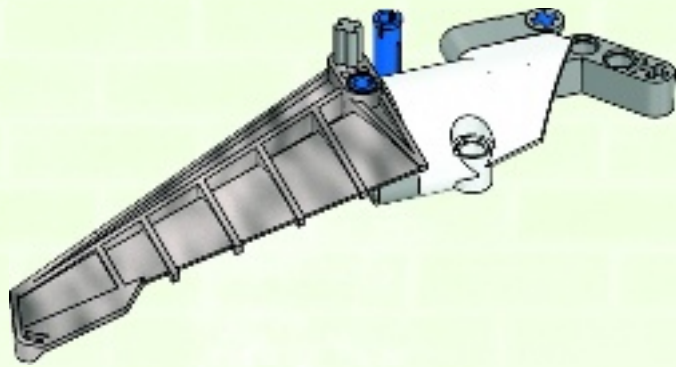

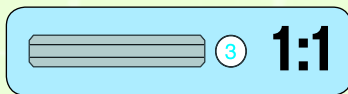
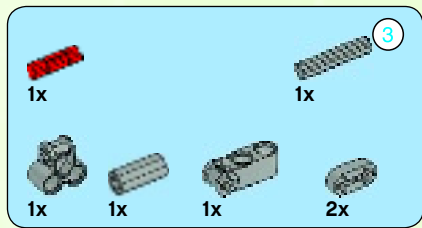

5

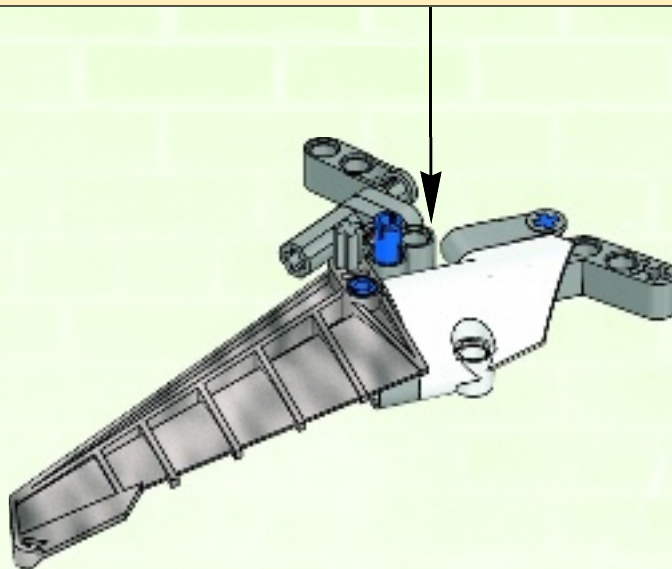
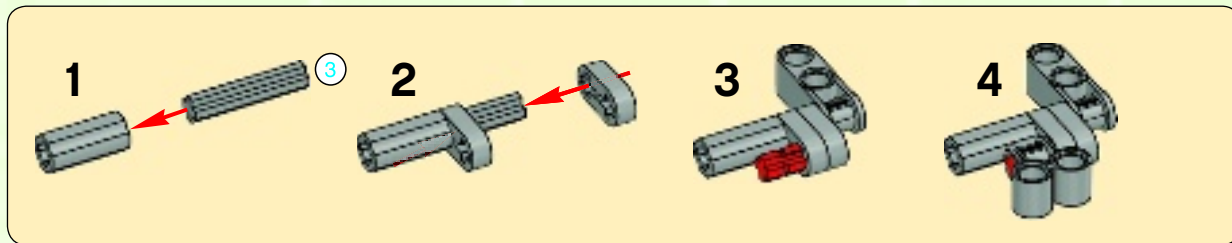

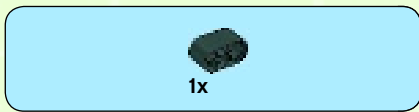

6

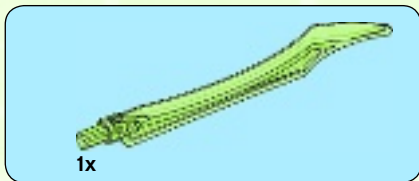
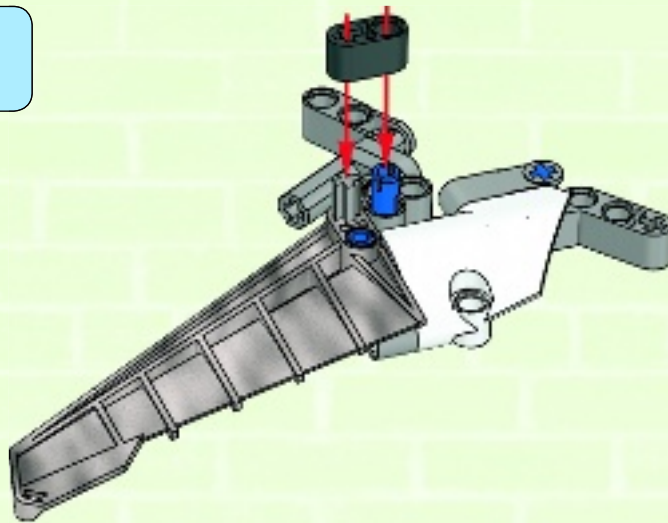

7

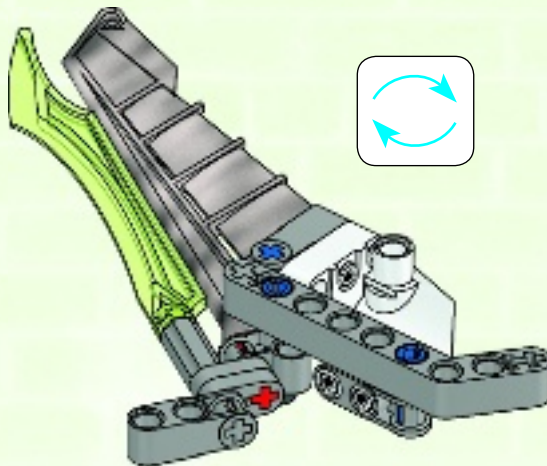

30

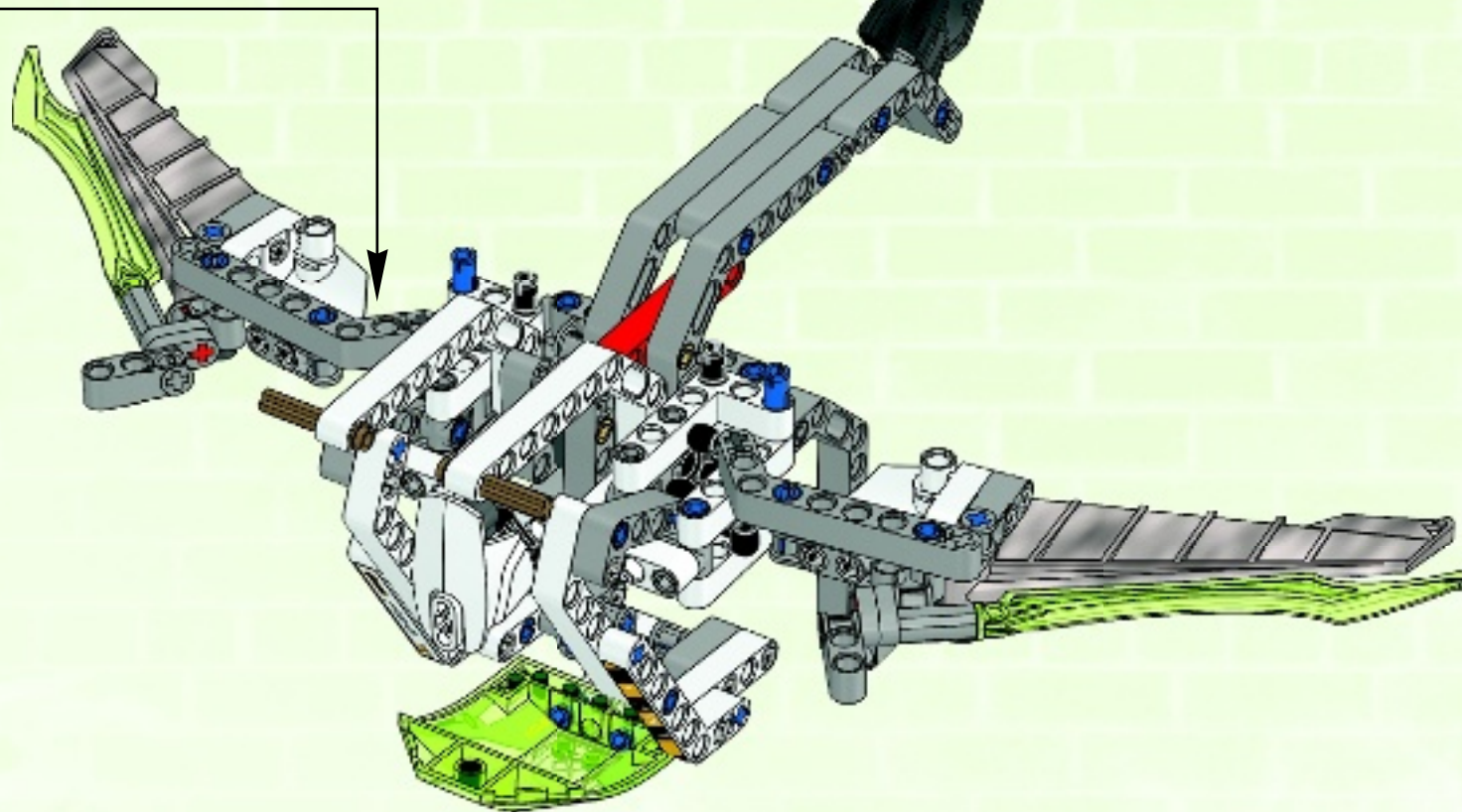

31

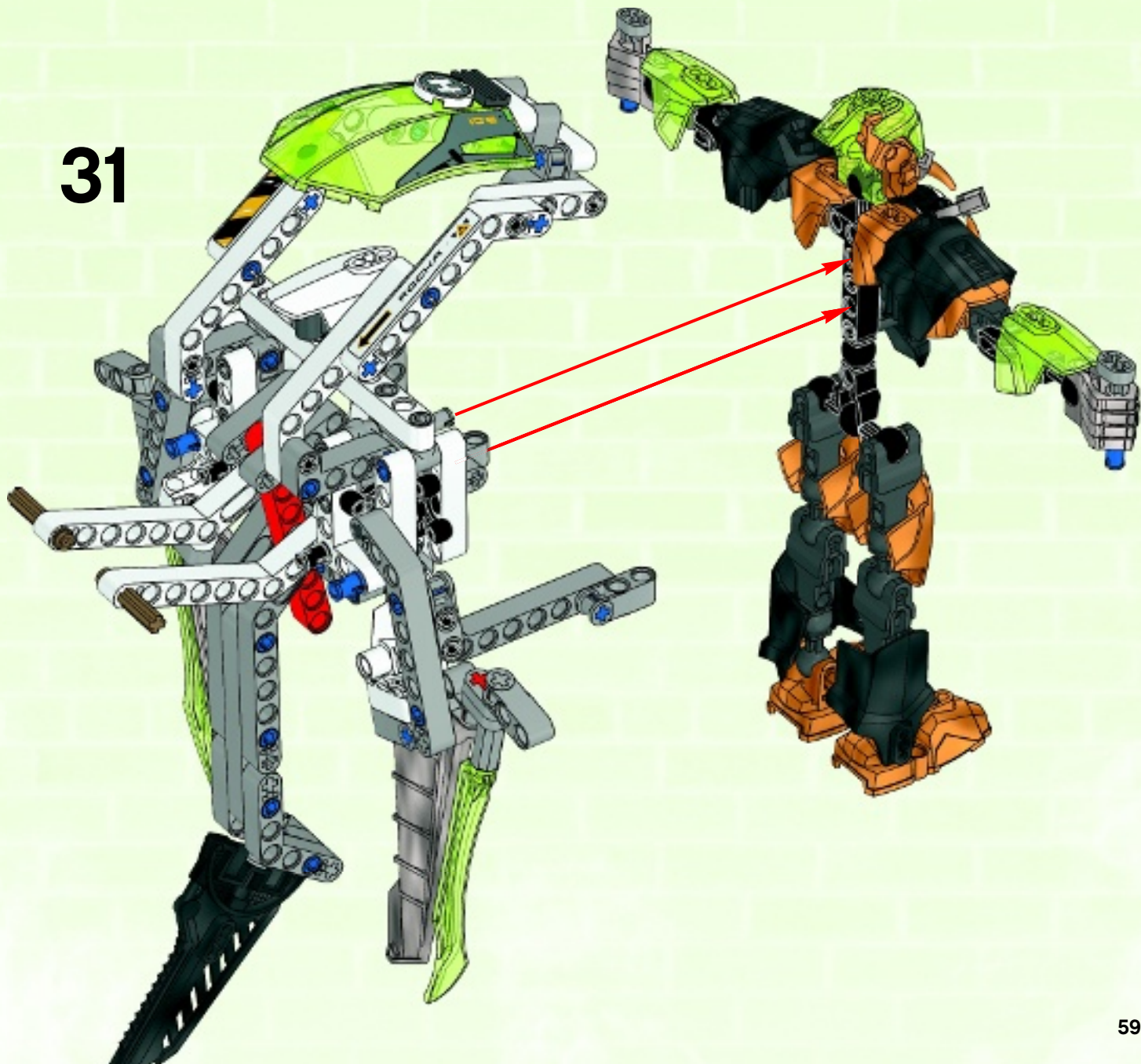

32

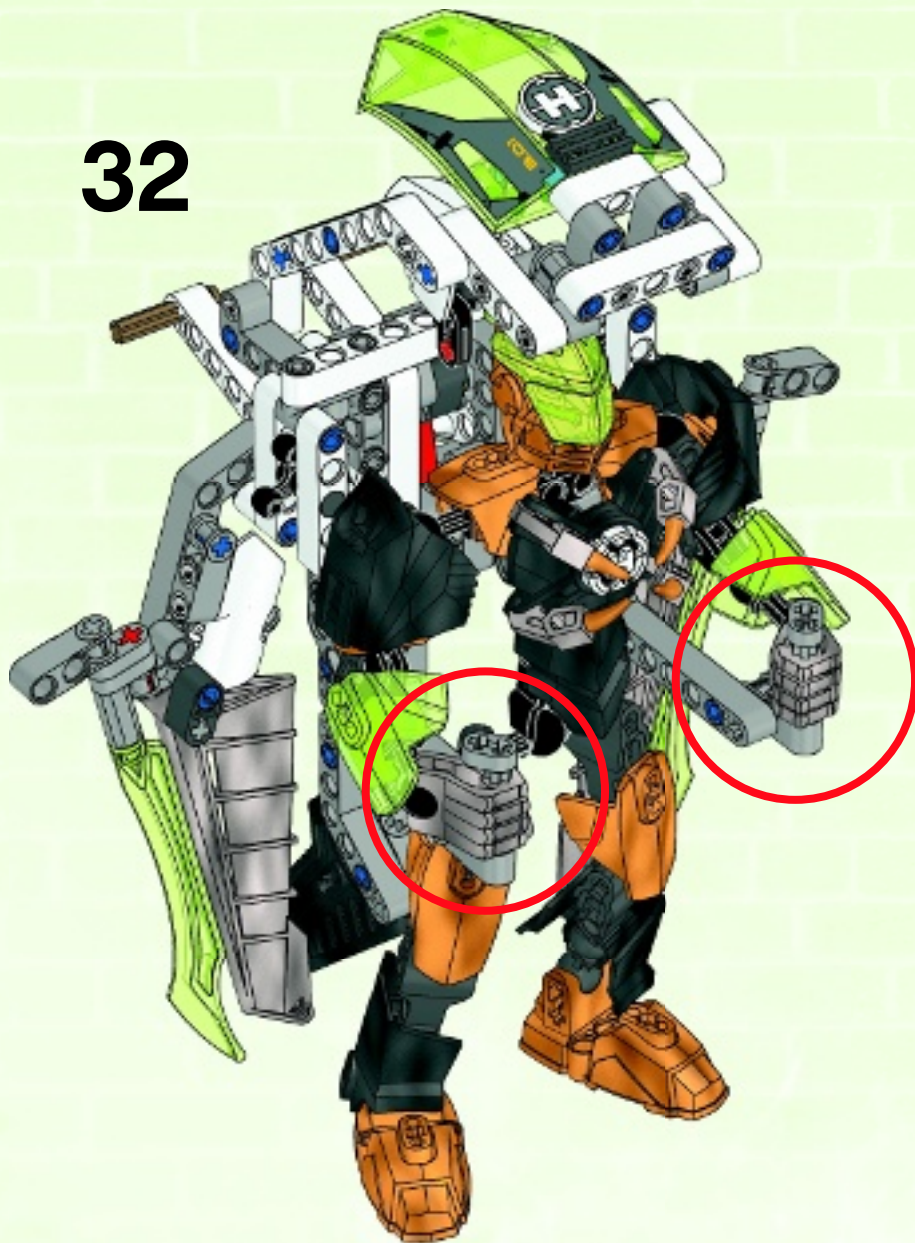

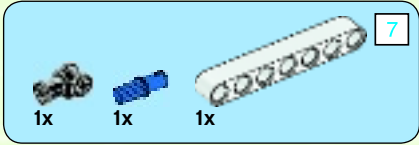
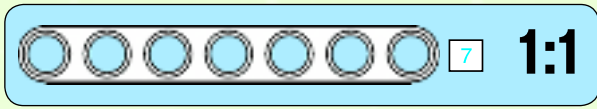

1

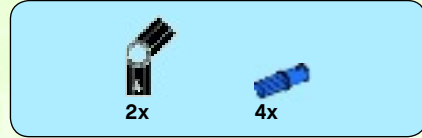
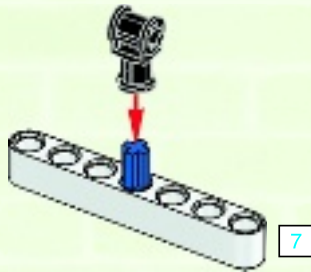

2

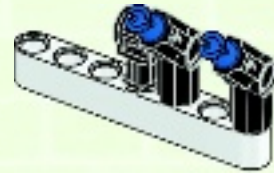
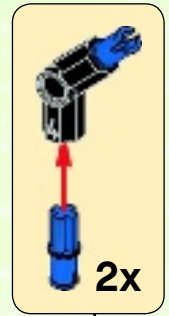

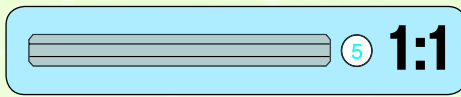
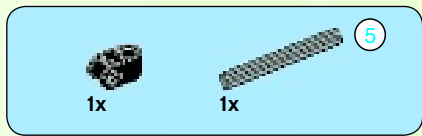

3

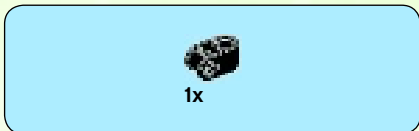
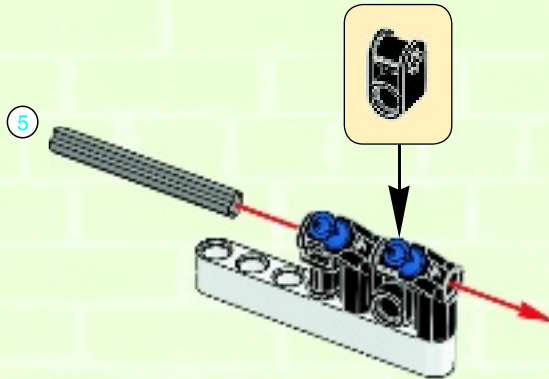

4

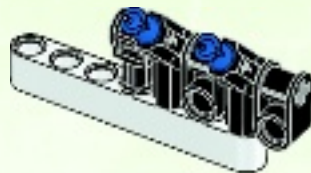

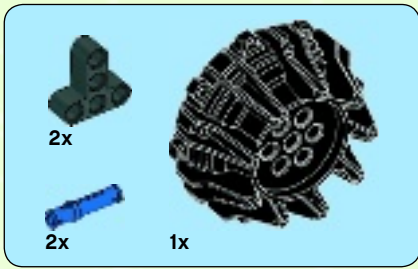

5

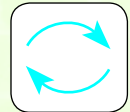
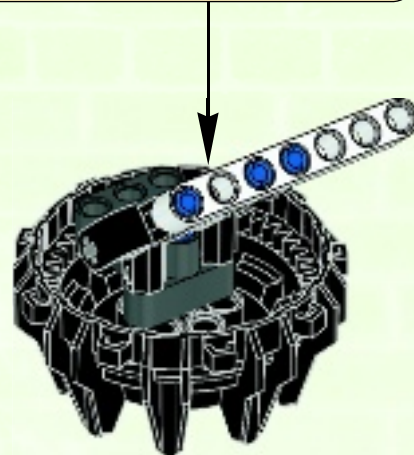
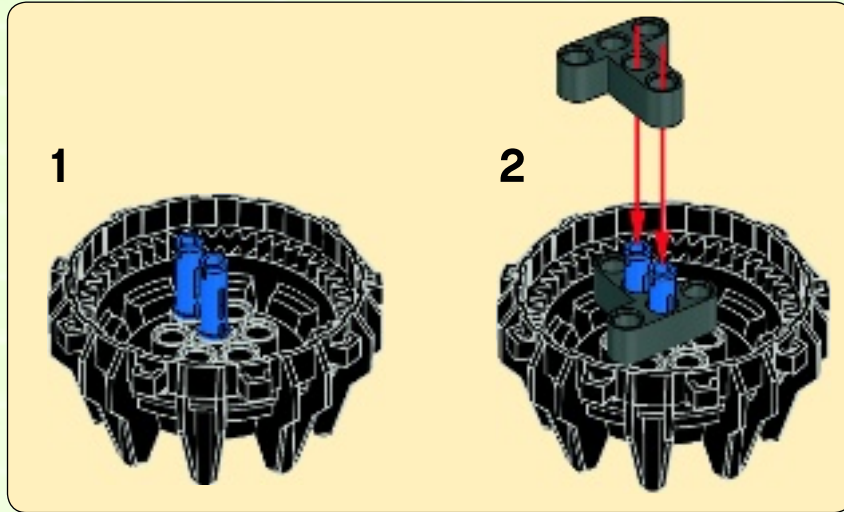

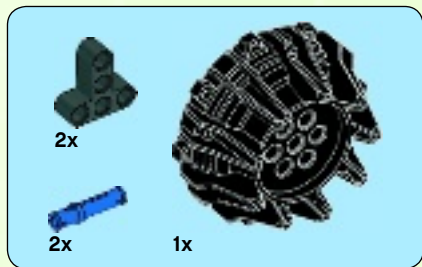

5

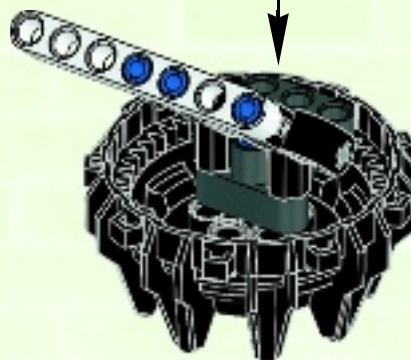
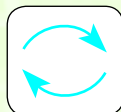
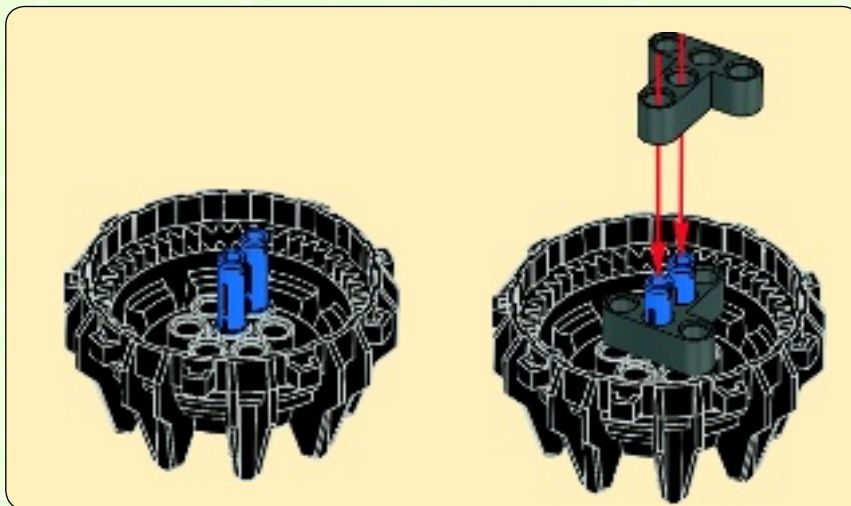

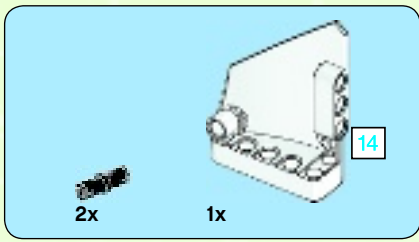

7

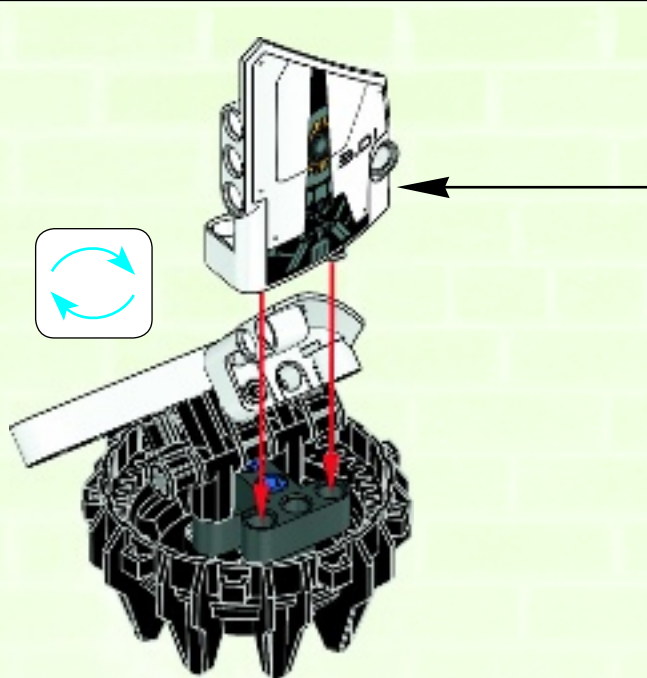
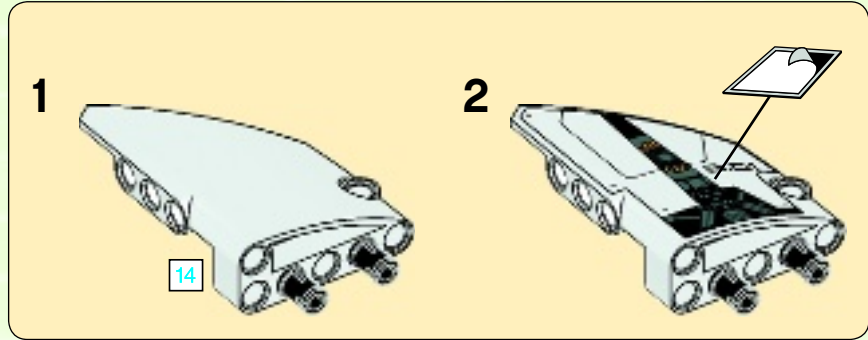

33

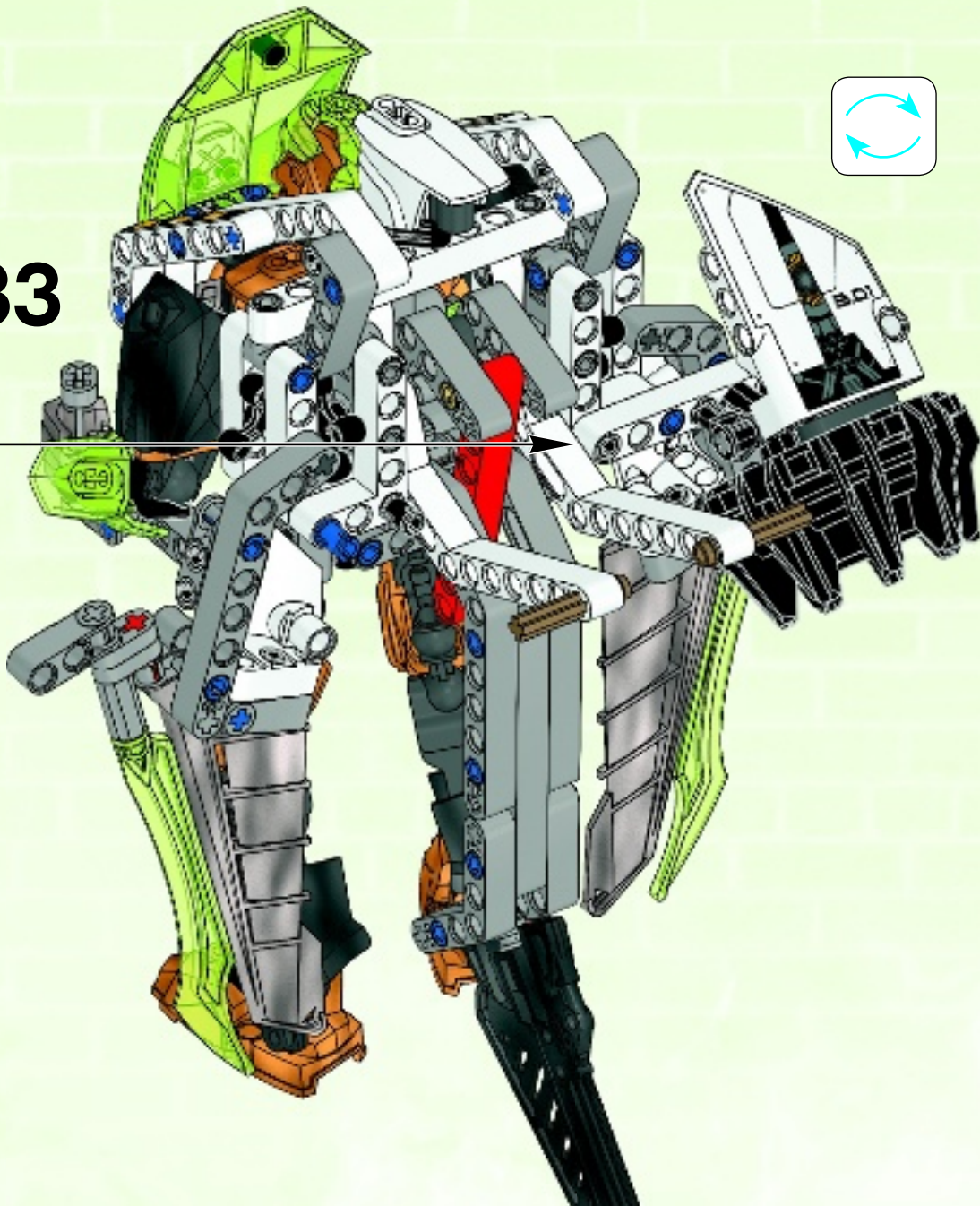
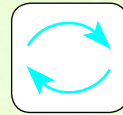

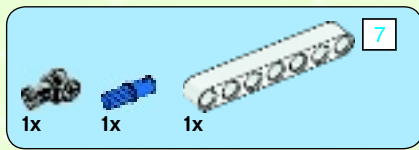

1

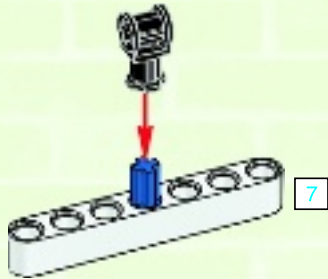

2

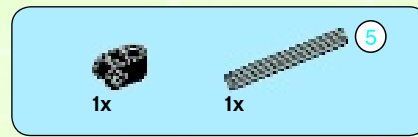
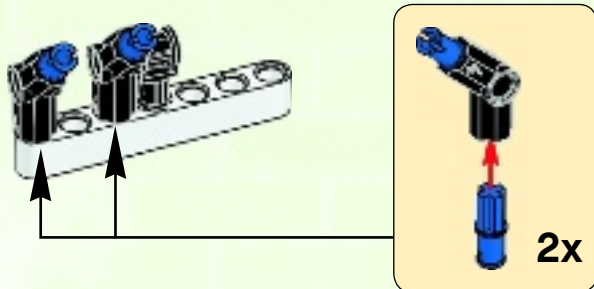

3

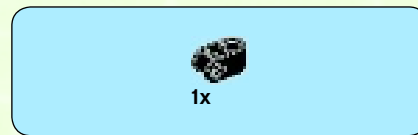
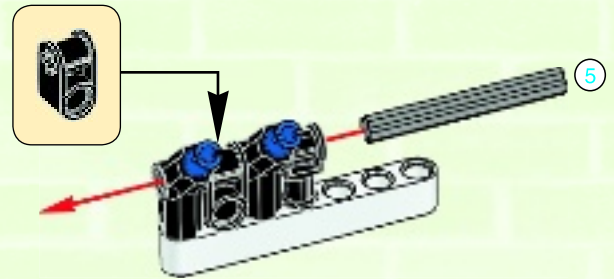
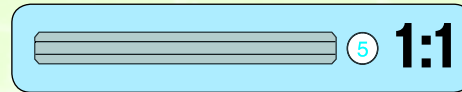

4

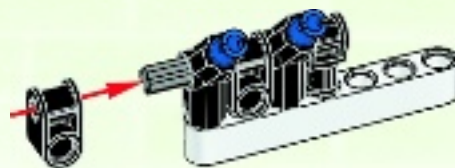

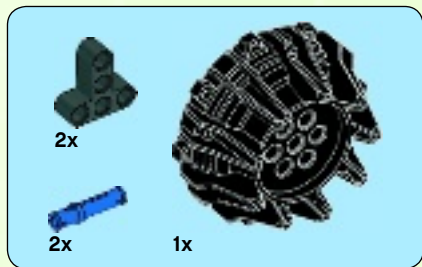

5

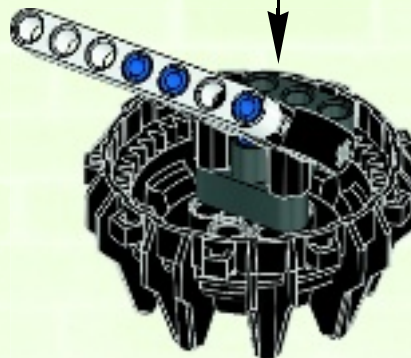
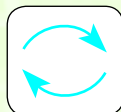
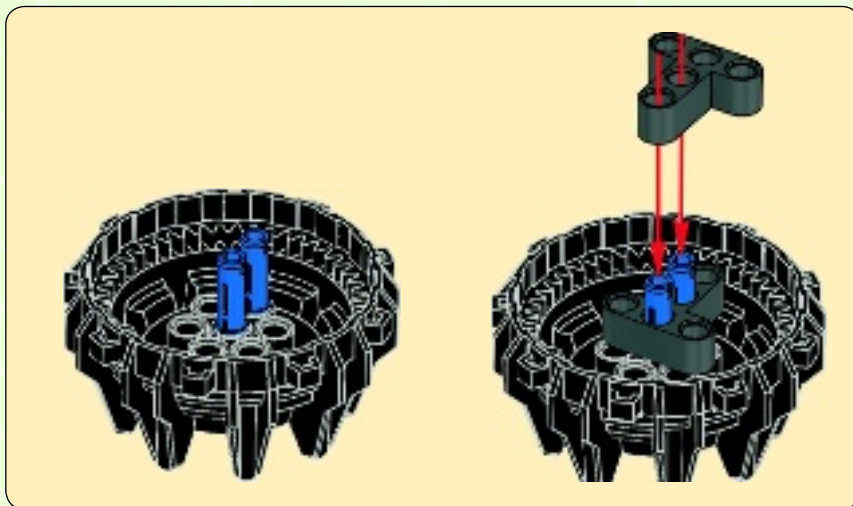

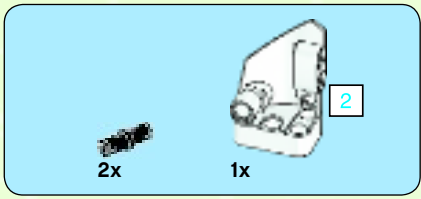

6

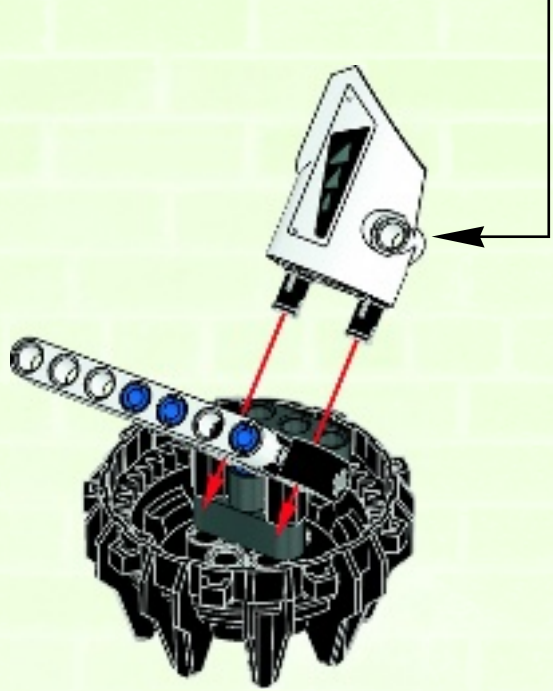
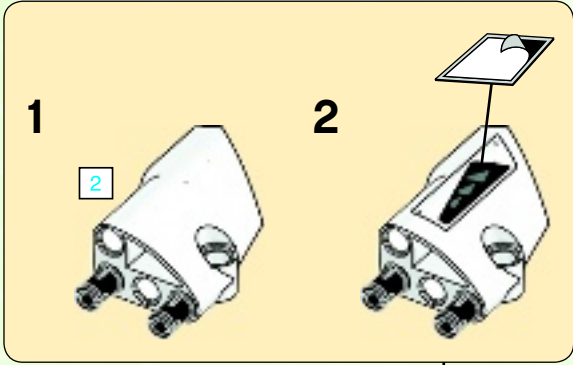

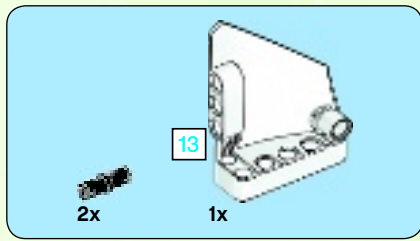

7

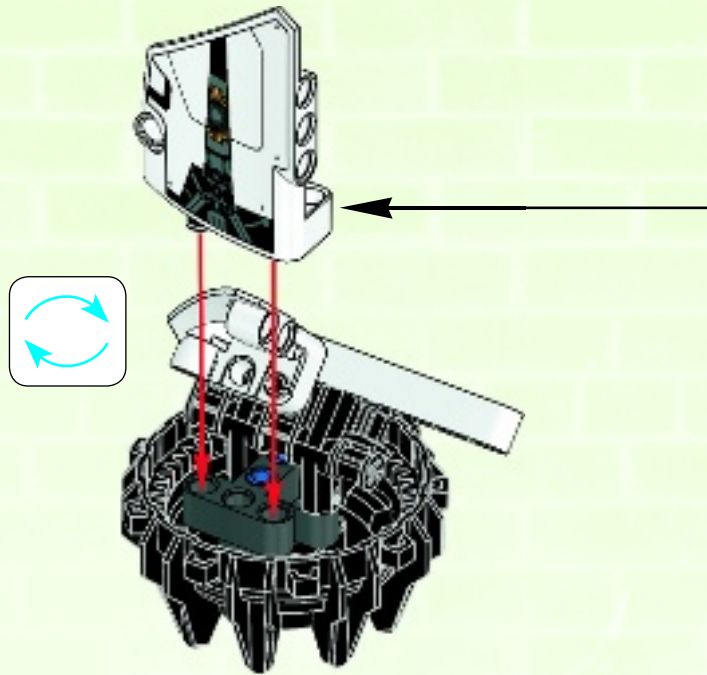
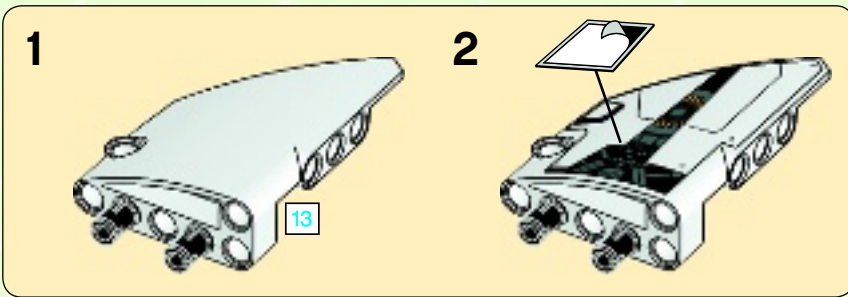

34

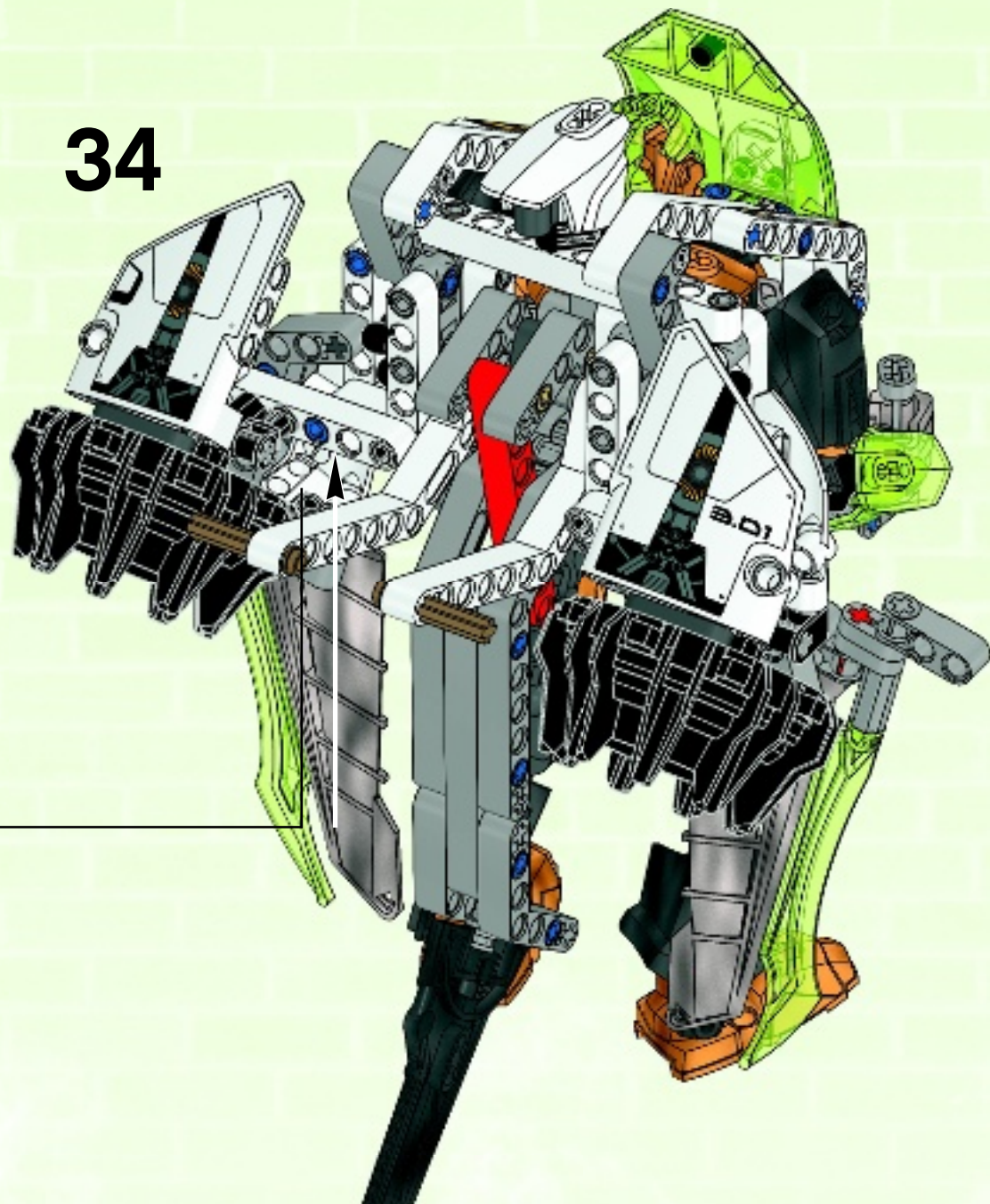

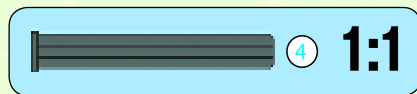
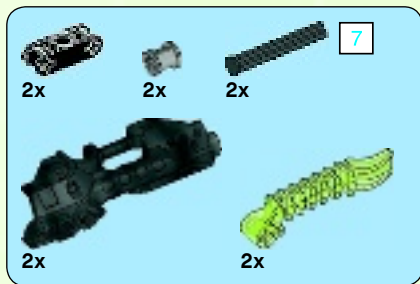

35

1

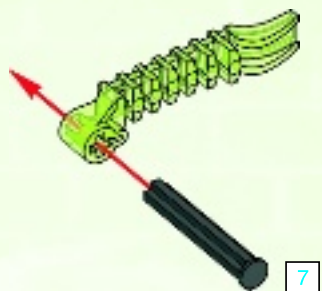

2

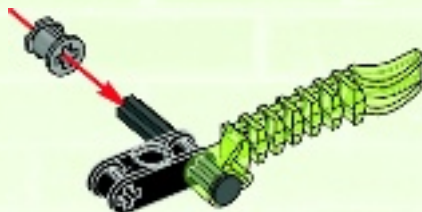

3



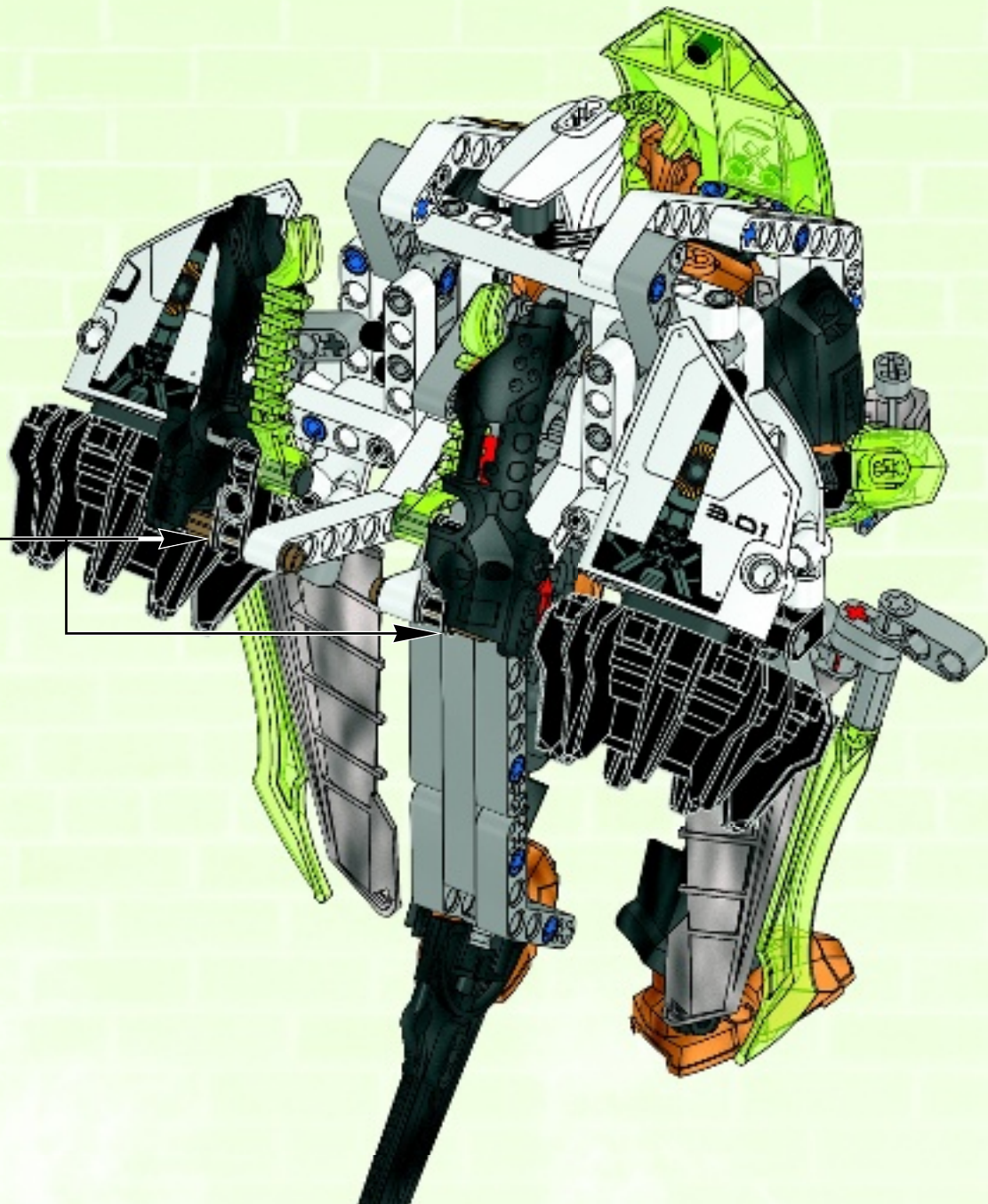

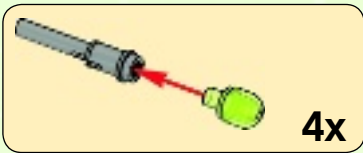
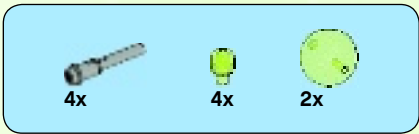

36

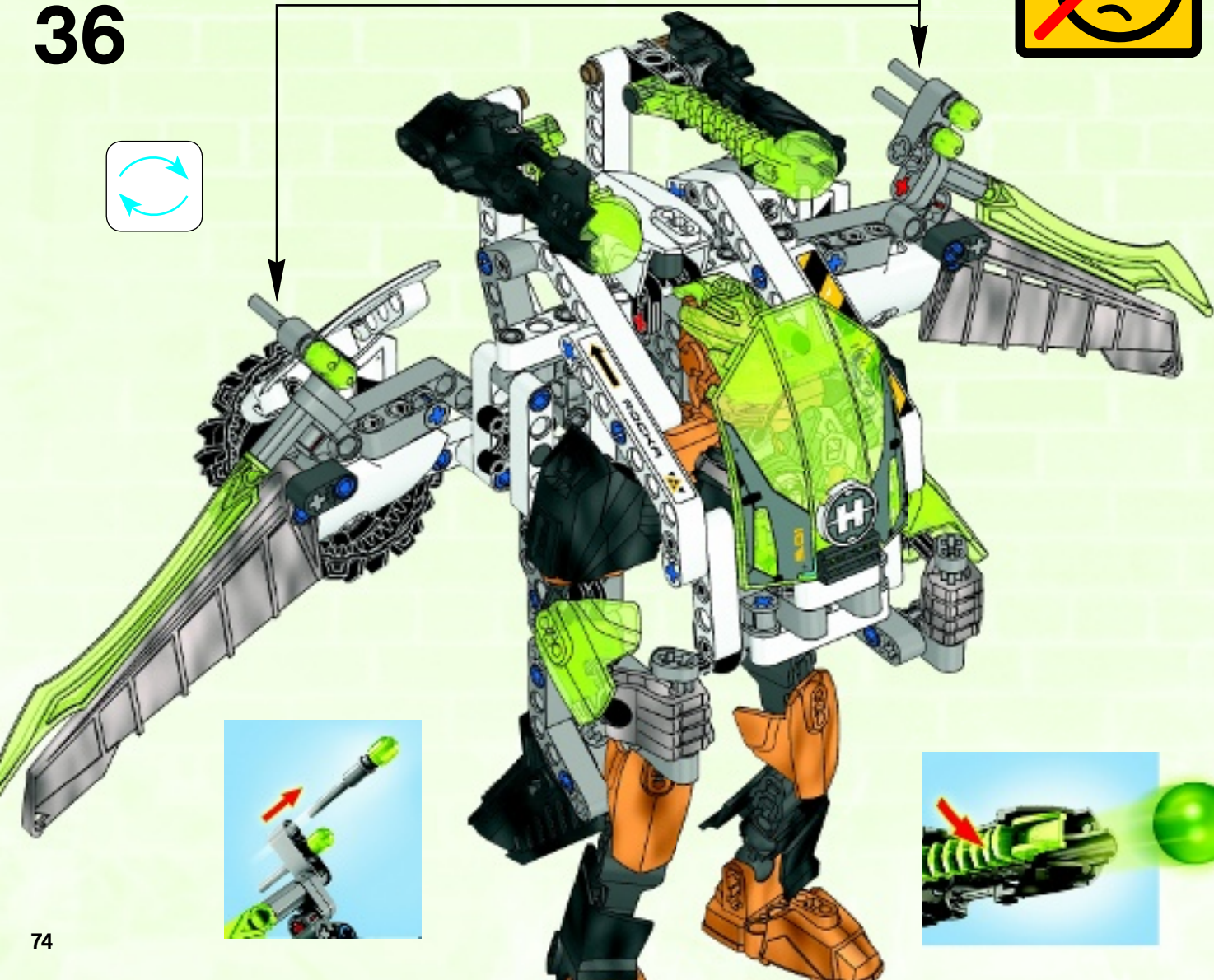



Customer Service

Kundenservice

Service Consommateurs

Servicio Al Consumidor

LEGO.com/service or dial



: 00800 5346 5555

: 1-800-422-5346

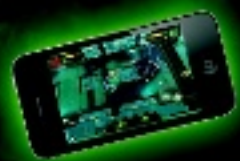

+1000

GAME POINTS POINTS À COLLECTIONNER PUNTOS DE JUEGO

Use the code - get 1000 game points
Utilise le code - obtiens 1000 points bonus
Consigue 1000 puntos para el juego en la web con este código



Available on the
App Store

ANDROID APP ON
Google play

LEGO.com/herofactory





44009



44010



44011



CHI ERIS
70201



CHI LAVAL
70200



CHI CRAGGER
70203



70205



70202



70204



CHI RAZAR
70205



CHI GORZAN
70202



CHI WORRIZ
70204





Available on the
App Store

ANDROID APP ON
Google play





club™

Free*! Gratuit!

* Paid subscription in Australia and New Zealand.
Abonnement payant en Australie et Nouvelle-Zélande



LEGO.com/club

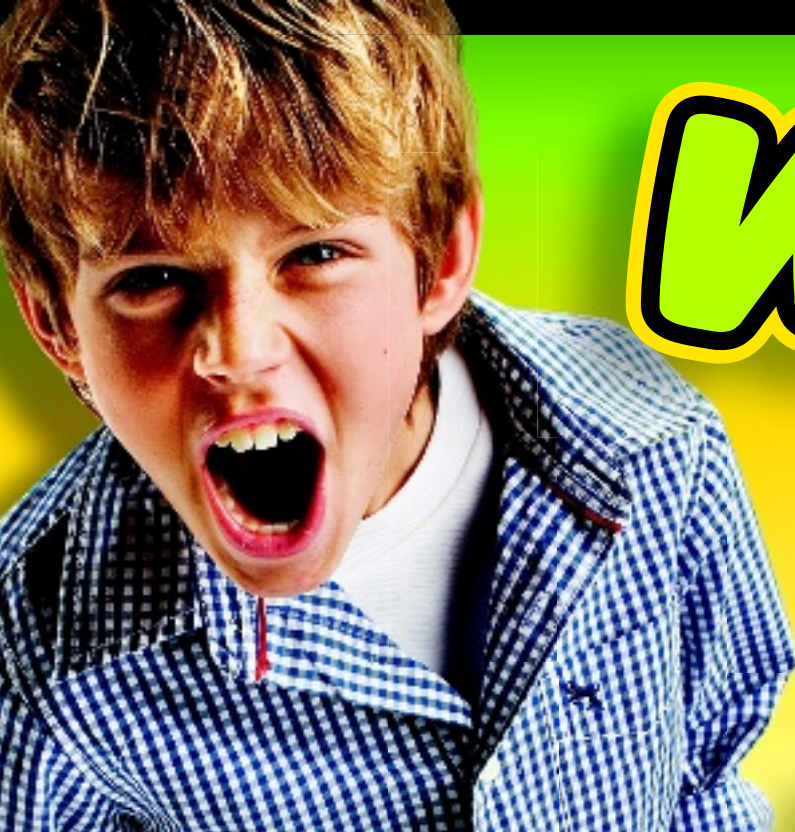

WIN!

Go to www.LEGOsurvey.com/product to fill out a survey for a chance to win a cool LEGO® Product.

No purchase necessary.

Open to all residents where not prohibited.



LEGO.com



www.LEGOsurvey.com/product

GEWINNE! WIN!

Nimm an der Umfrage auf www.LEGOsurvey.com/product teil und hab die Chance ein cooles LEGO® Produkt zu gewinnen!

Die Teilnahme am Gewinnspiel führt zu keinerlei Kaufverpflichtungen. Teilnahme in allen nicht ausgeschlossenen Ländern möglich.

Ga naar www.LEGOsurvey.com/product, vul een enquêteformulier in en maak kans op een cool LEGO® product.

Geen aankoopverplichting. Iedereen mag deelnemen, uitgezonderd ingezetenden van landen waar een enquêteverbod geldt.

GAGNE! 当てよう!

Visite www.LEGOsurvey.com/product pour répondre à un questionnaire et avoir une chance de gagner un produit LEGO® très cool!

Aucune obligation d'achat. Ouvert à tous les résidents des pays autorisés.

www.LEGOsurvey.com/product にアクセスして、アンケートにご記入ください。当選者にはレゴ®製品を差し上げます。

お買い上げの必要はありません

禁止されていない限り、すべての皆様にご利用いただけます。