



CITY

3221



WARNING: CHOKING HAZARD.
Small parts. Not for children under 3 years.

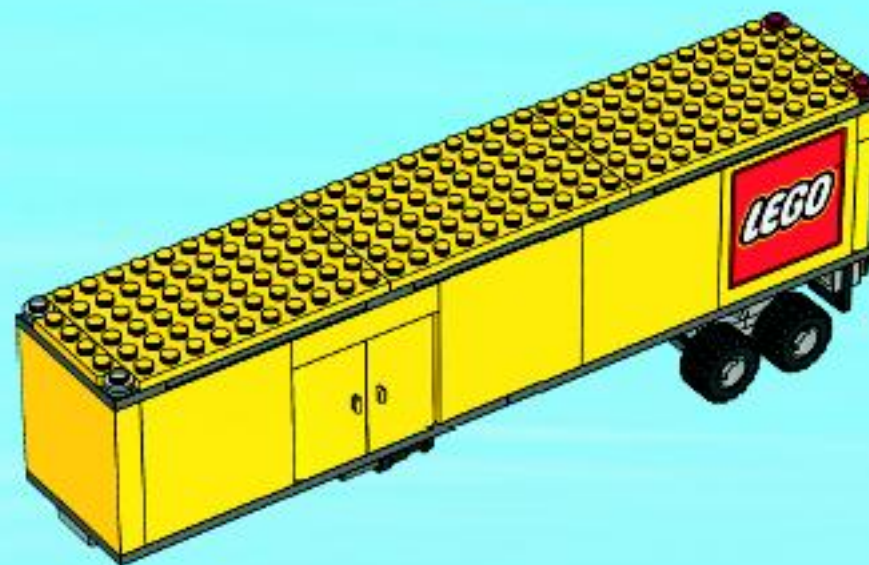

AVERTISSEMENT : RISQUE D'ÉTOUFFEMENT.

Contient des petites pièces. Ne convient pas aux enfants de moins de 3 ans.



ADVERTENCIA: PELIGRO DE ASFIXIA.

No recomendado para niños menores de 3 años. Contiene piezas pequeñas.

1

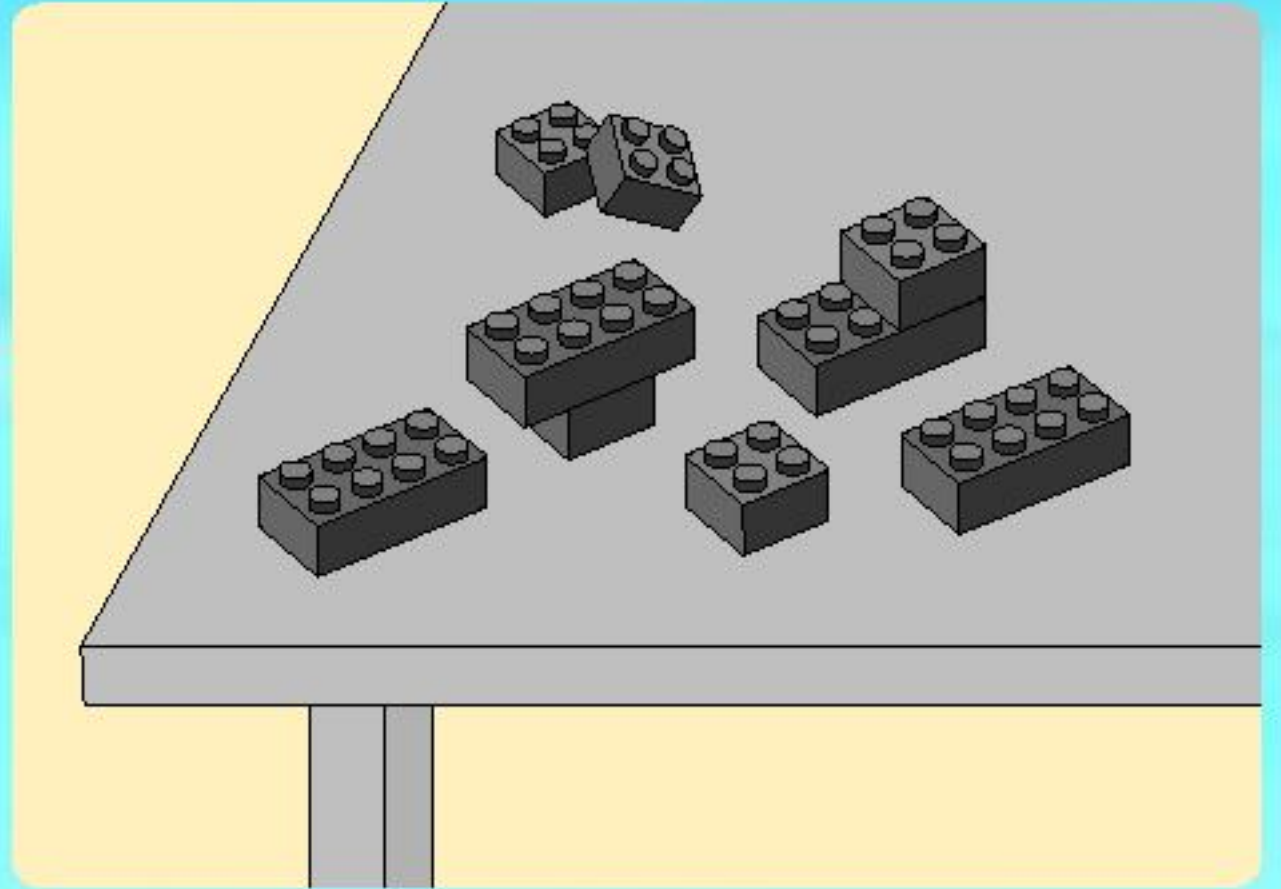
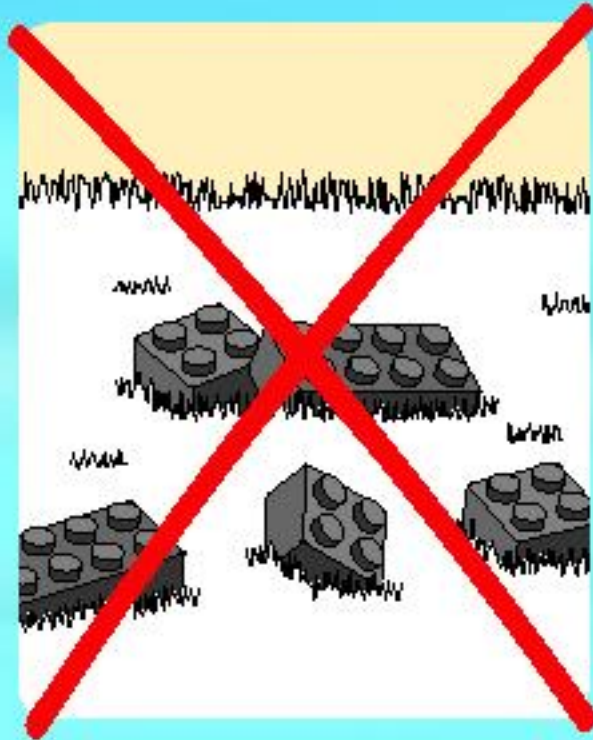

2



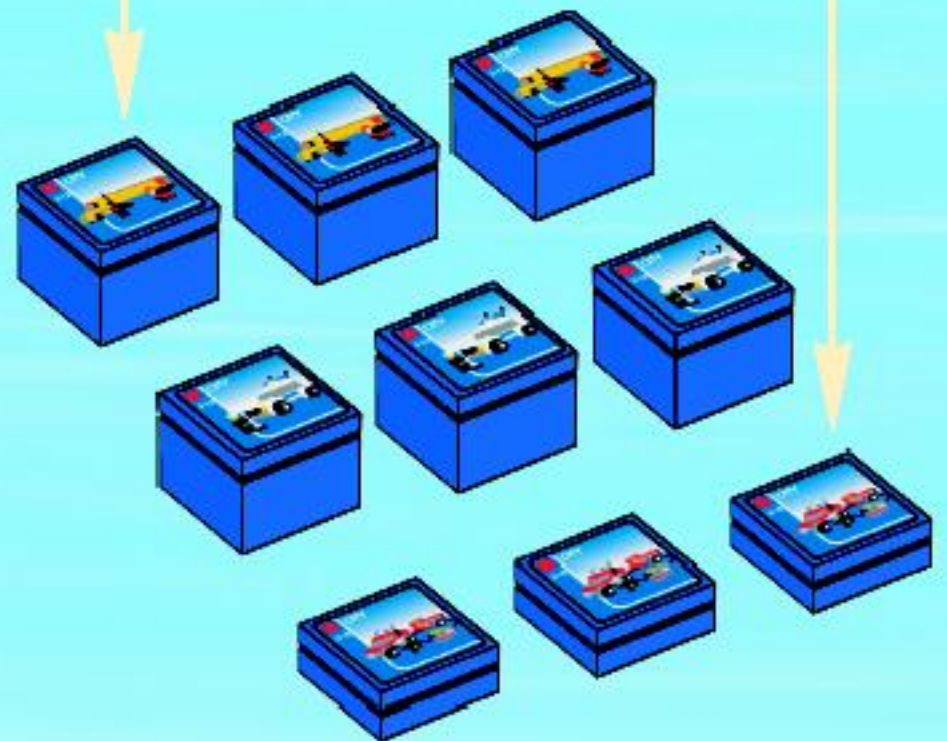
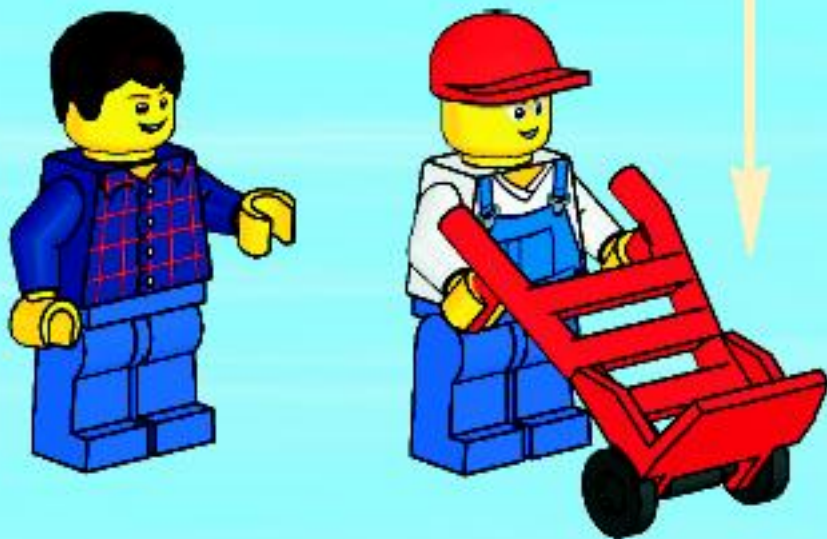
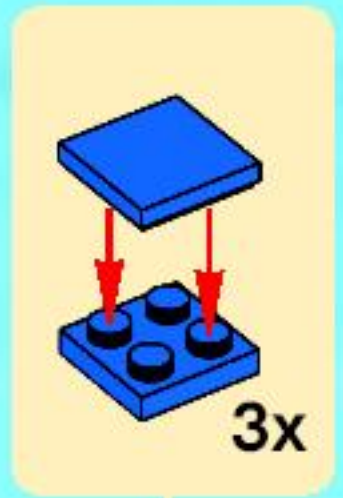
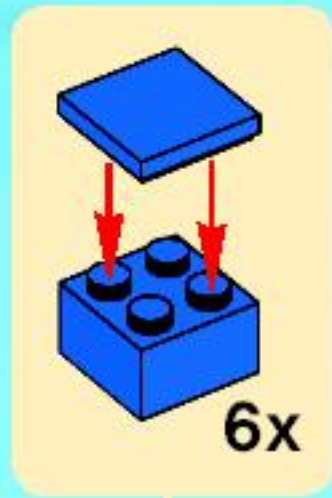
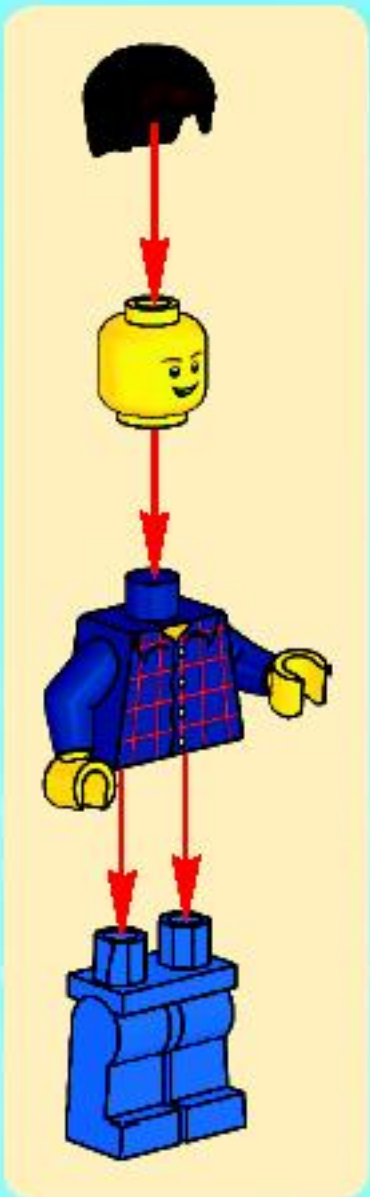
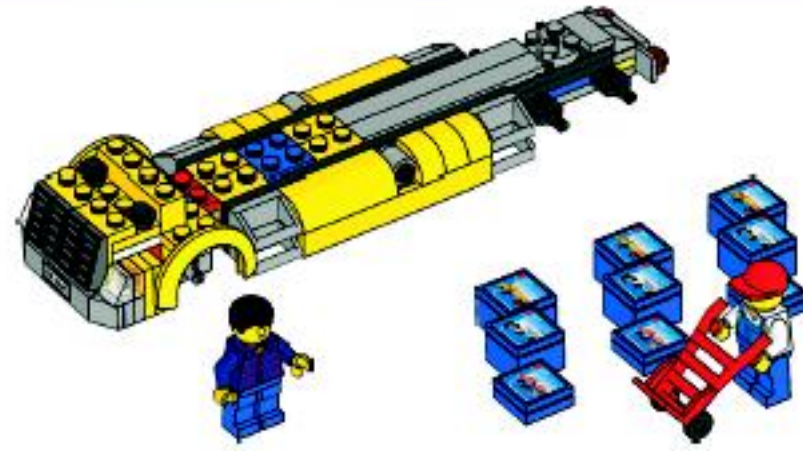

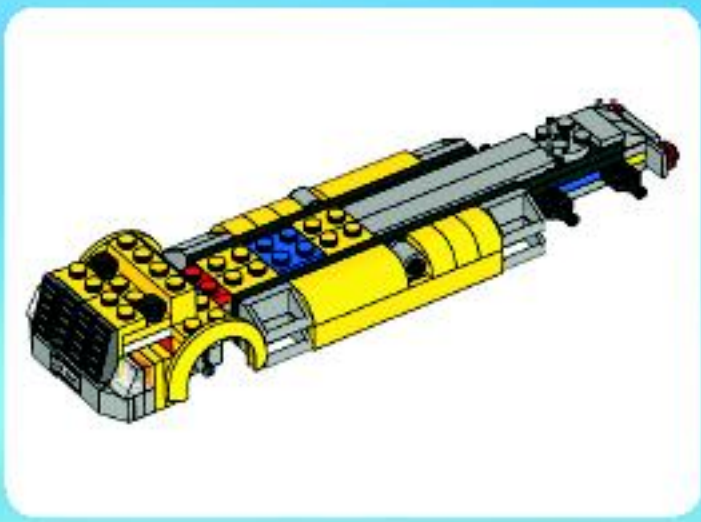

1

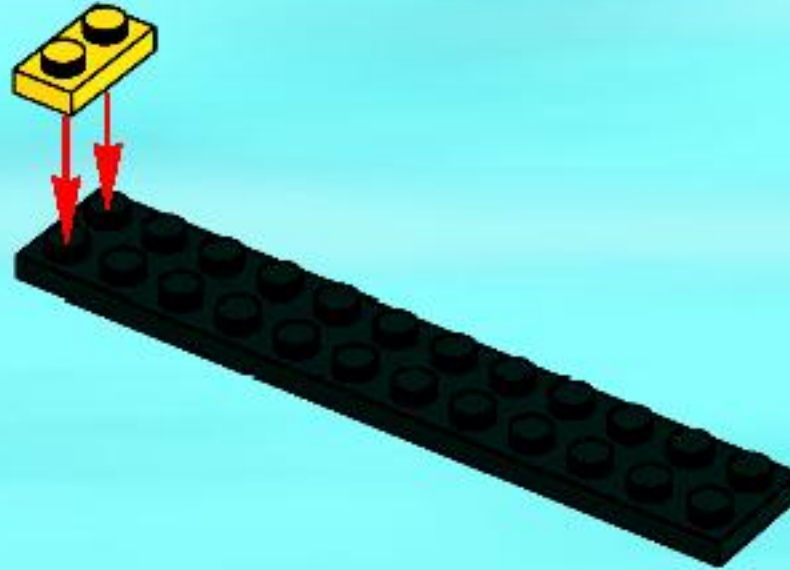

2

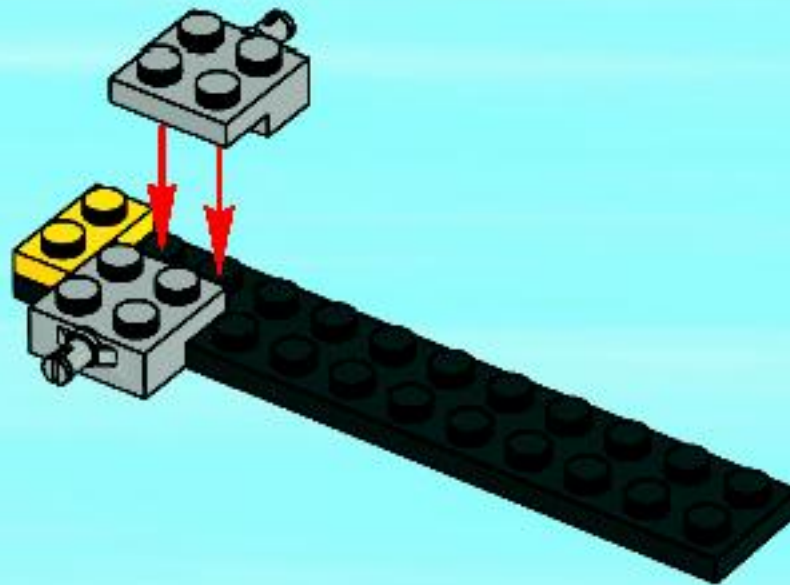

3

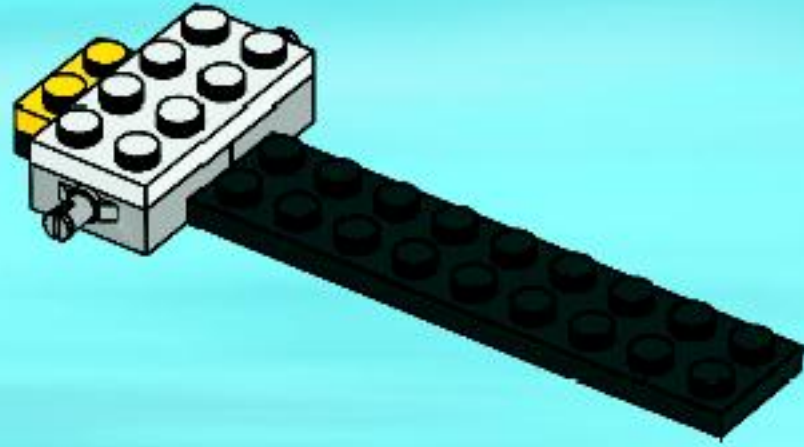

4

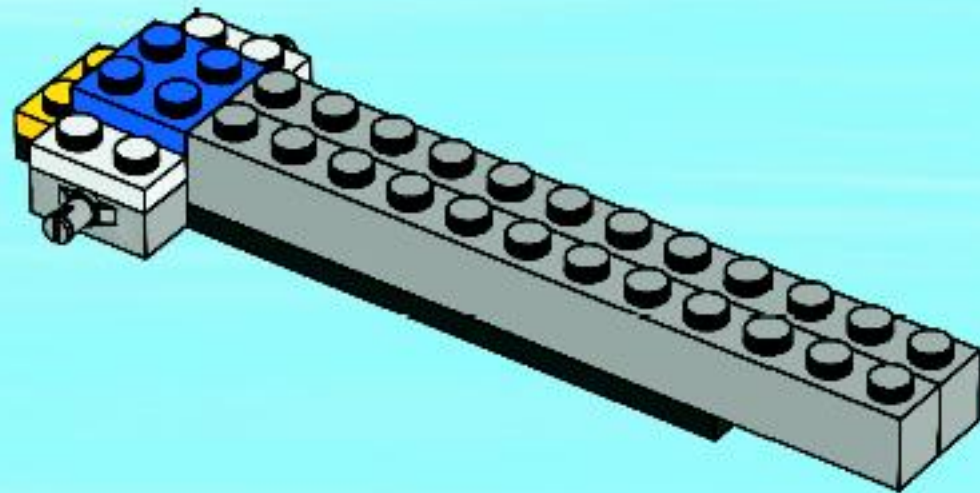

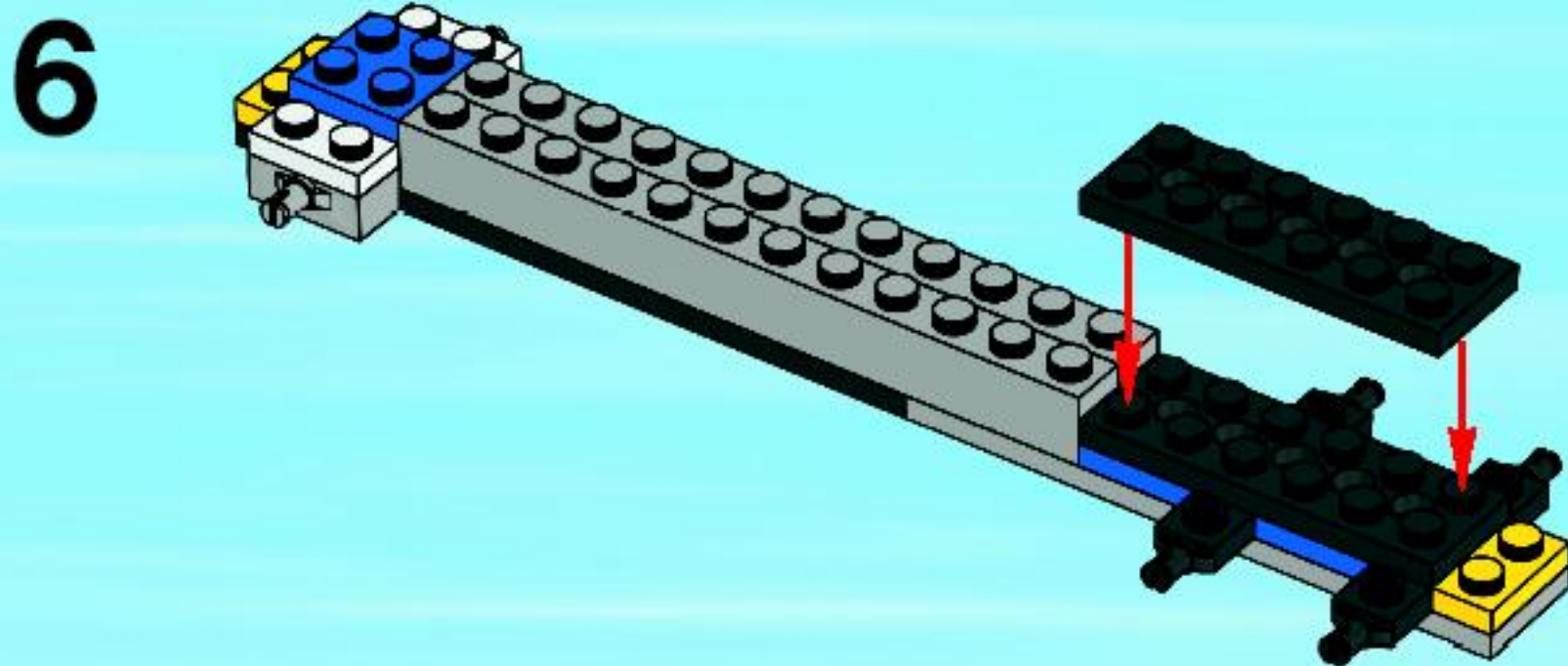
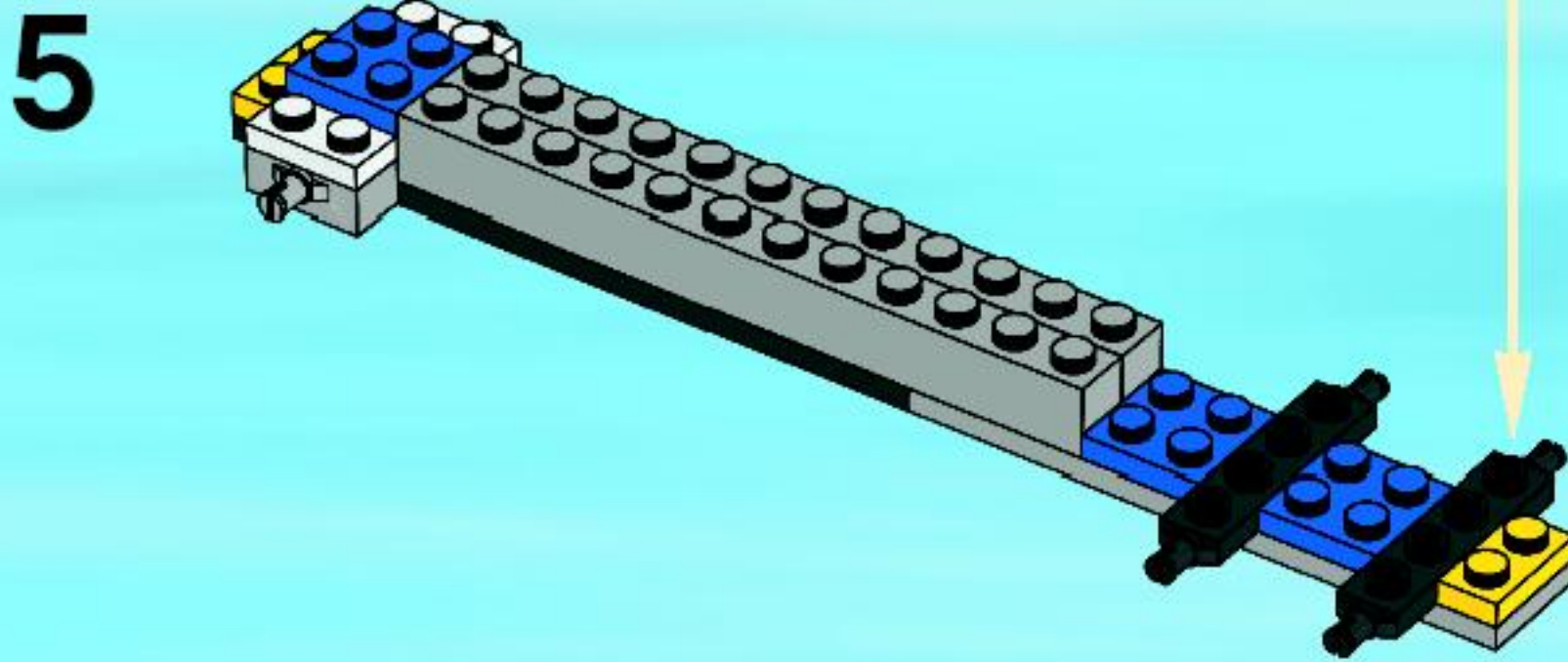
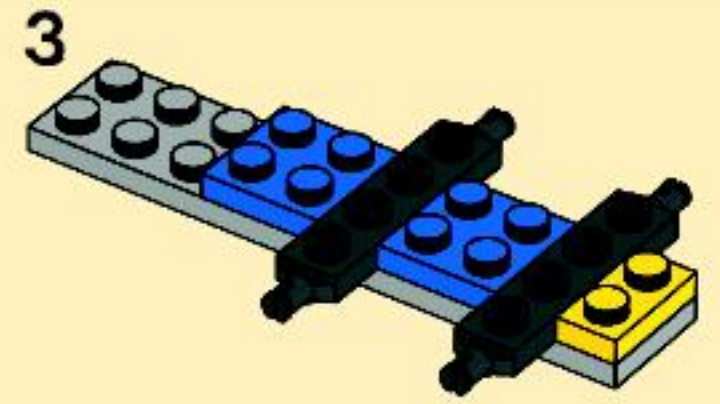
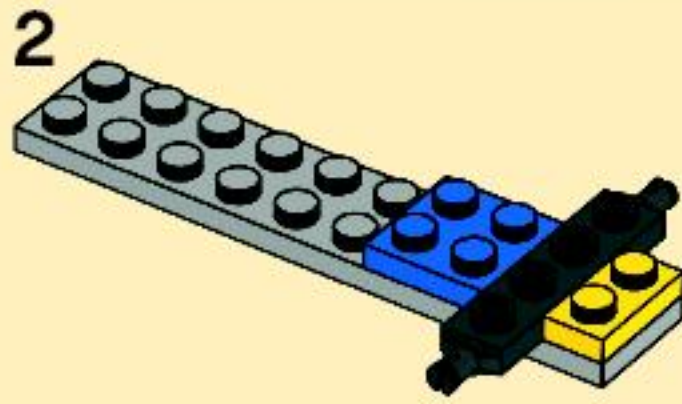
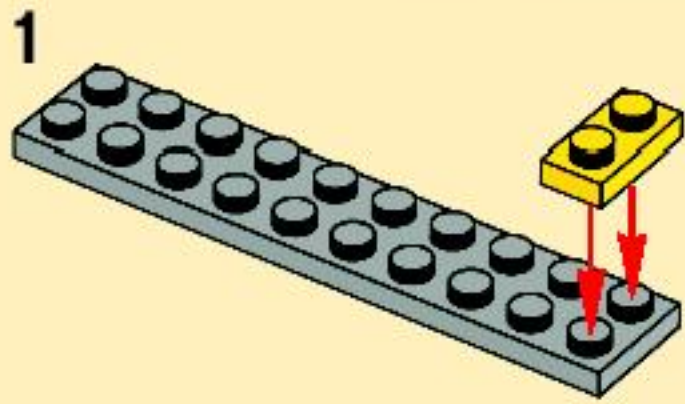

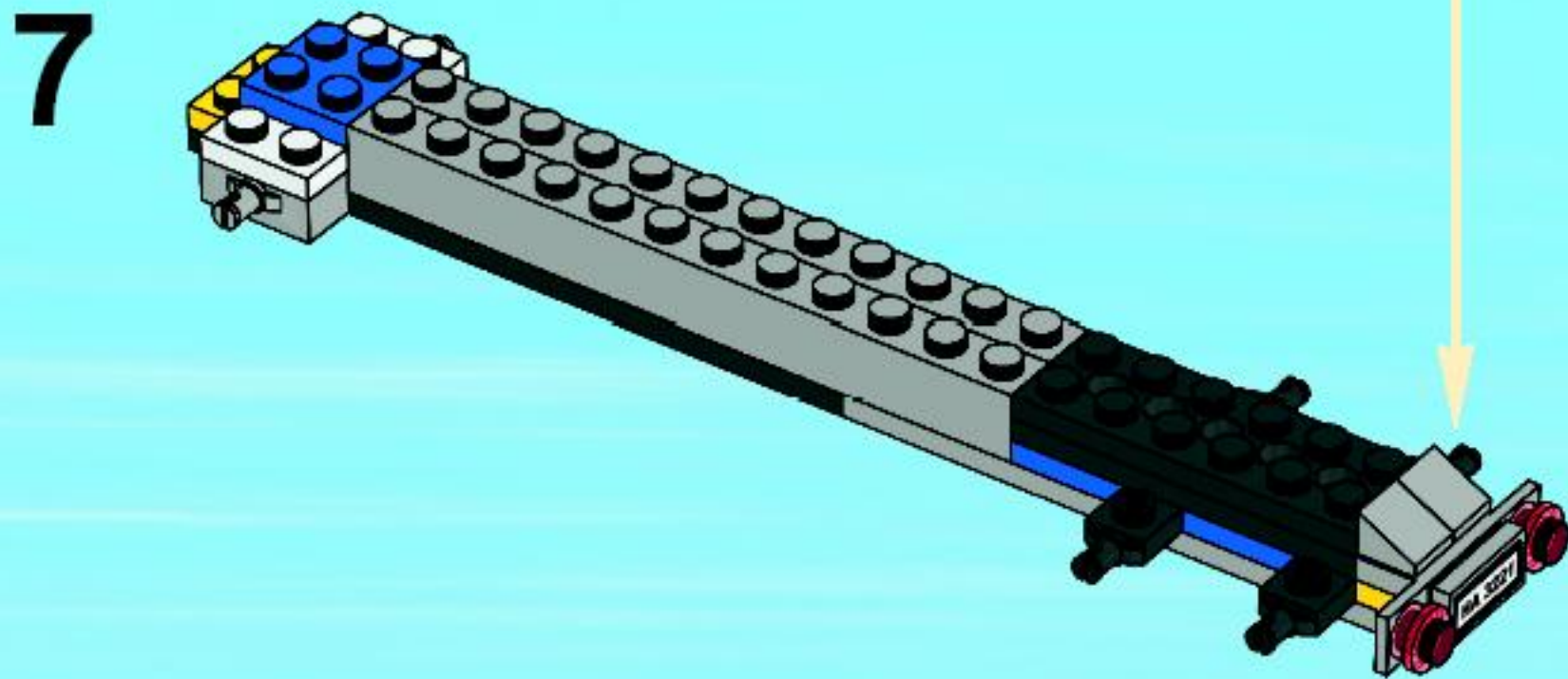
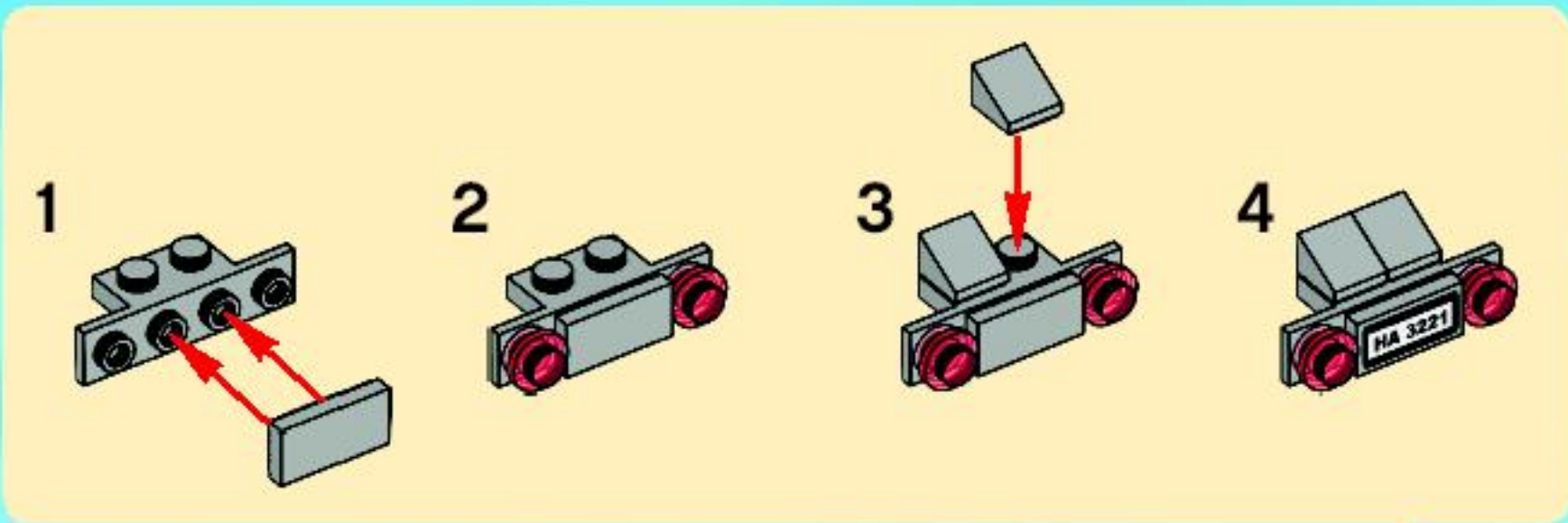

8

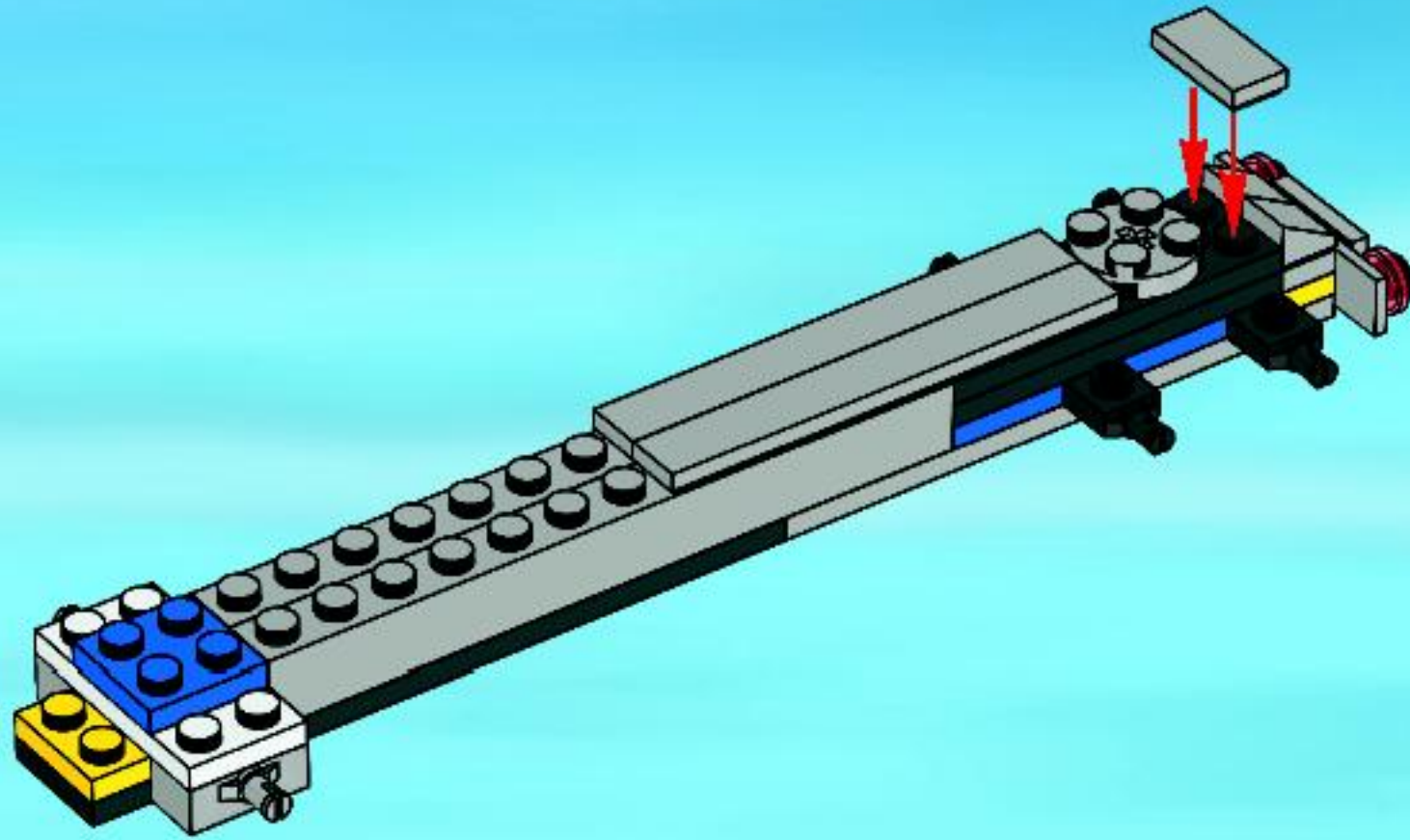

9

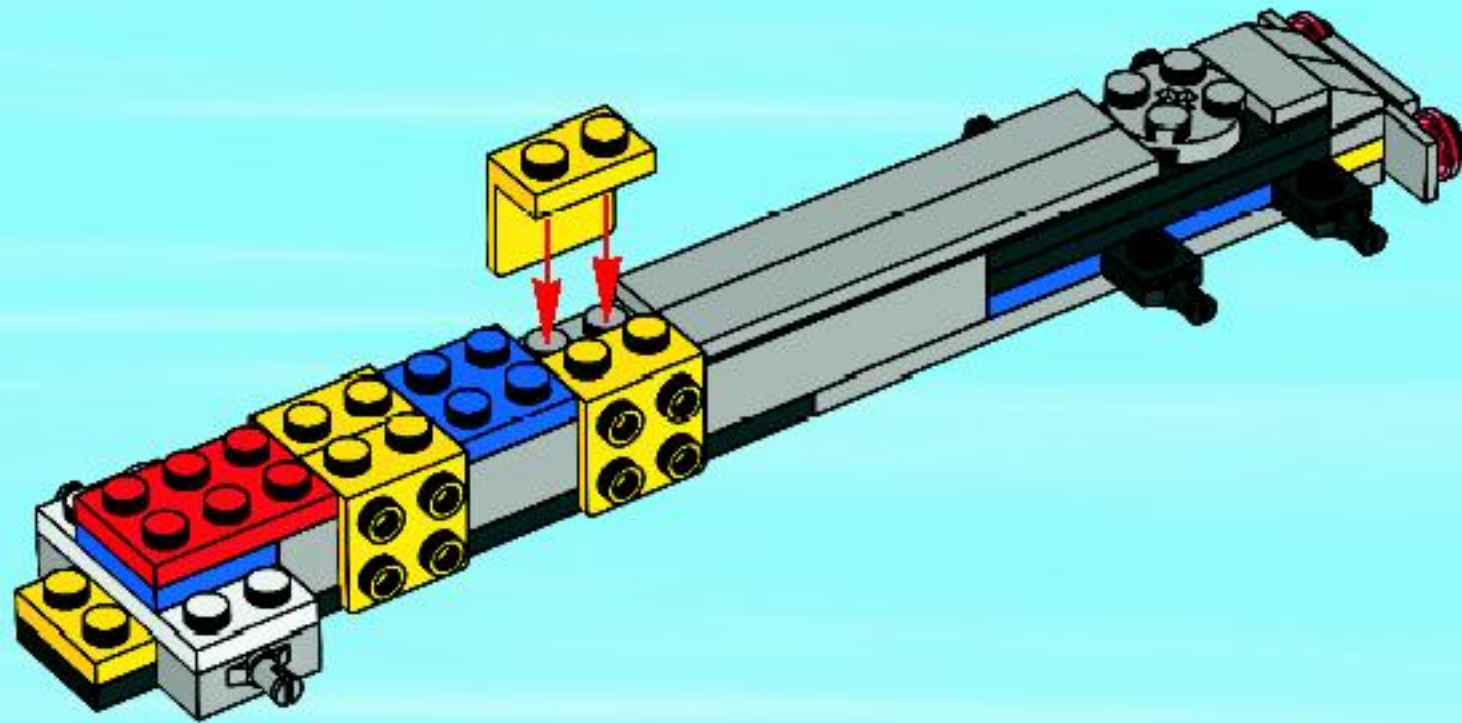

10

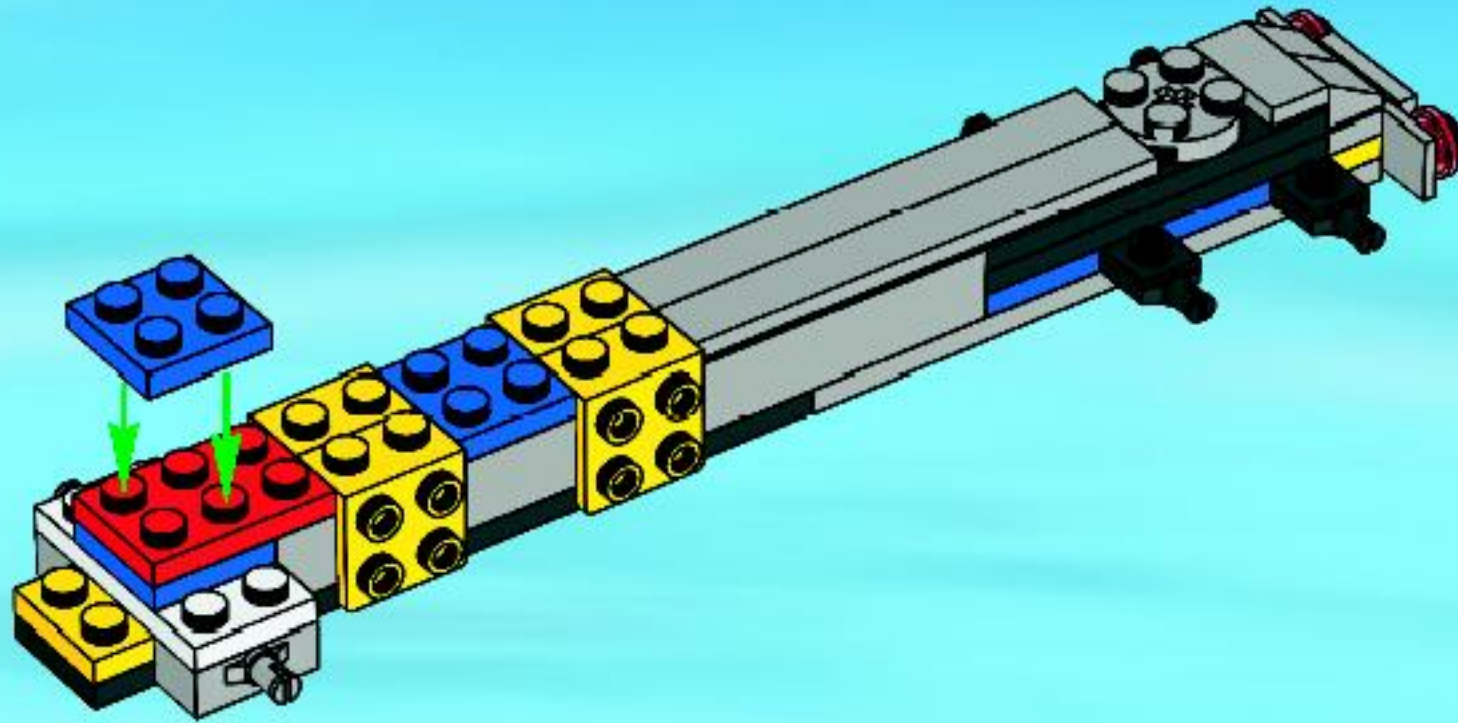

11

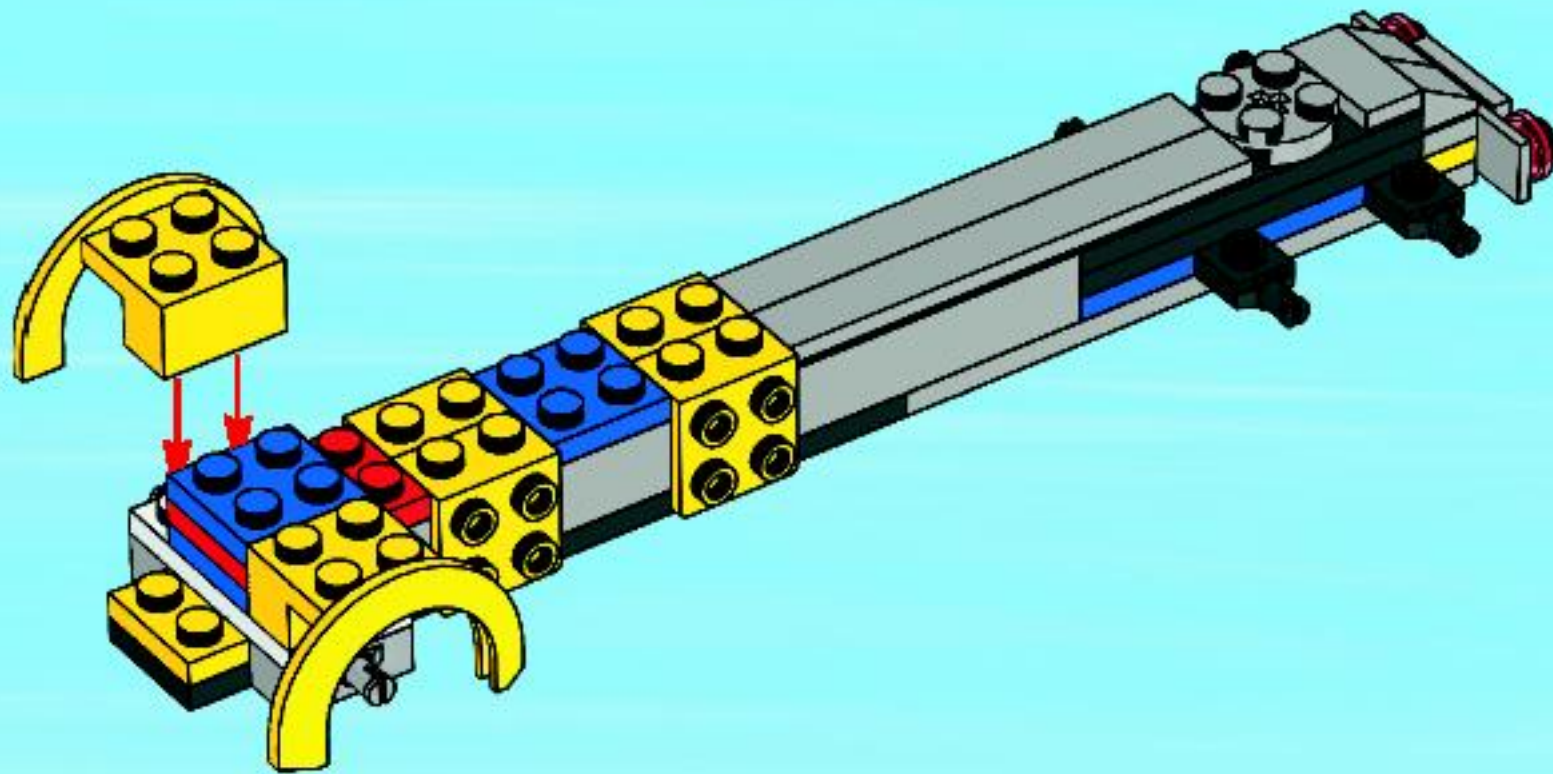

12

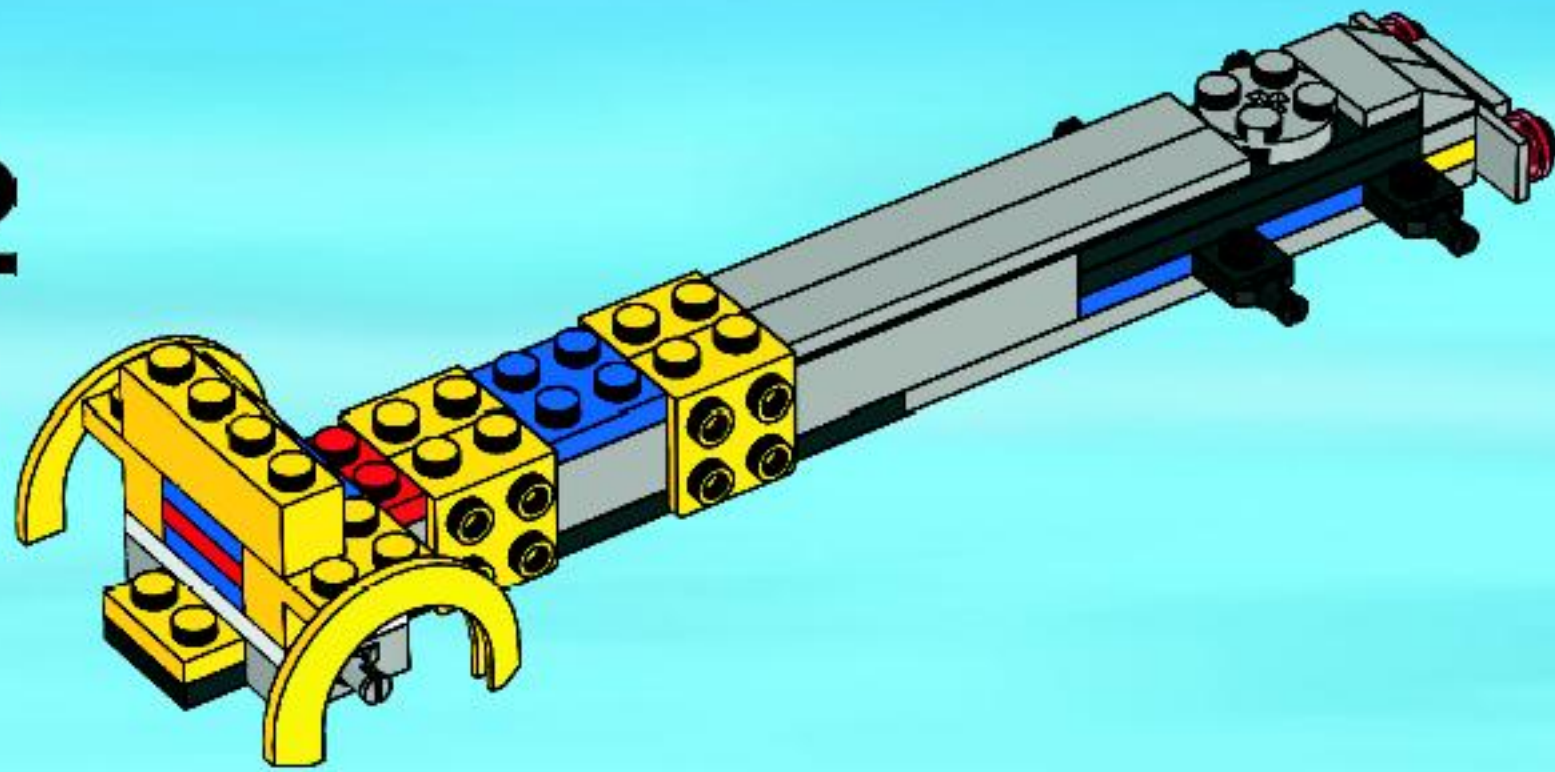

13

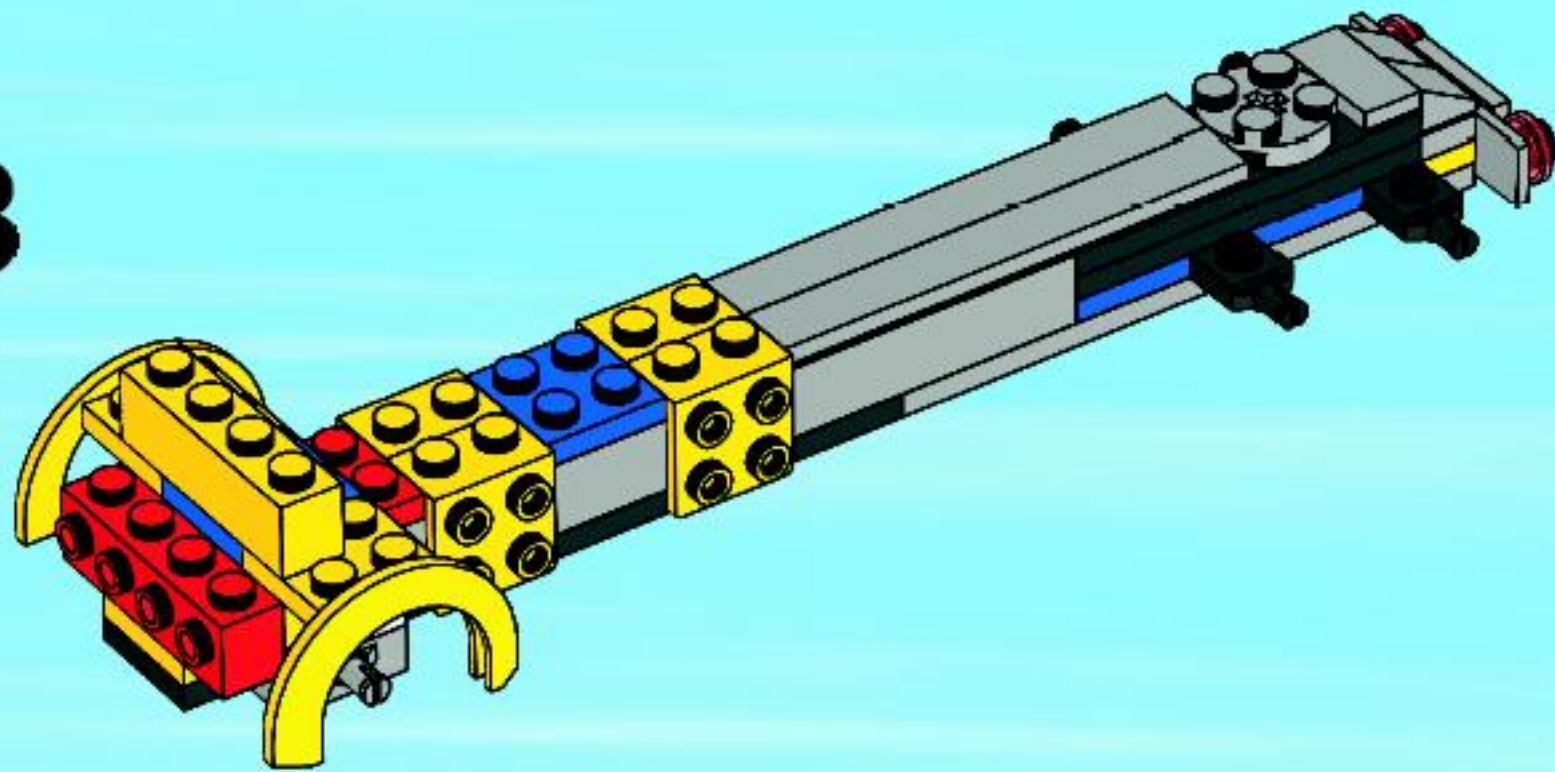

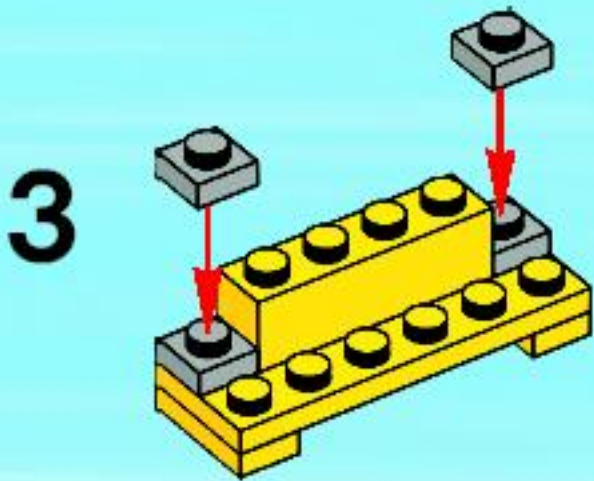
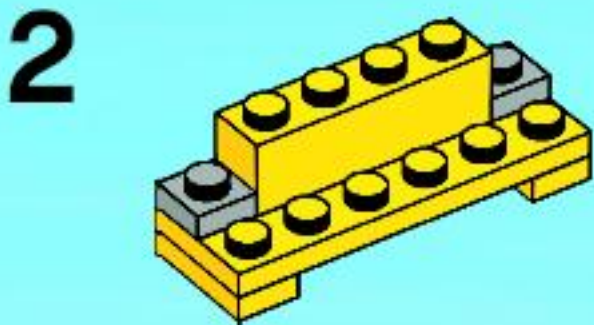
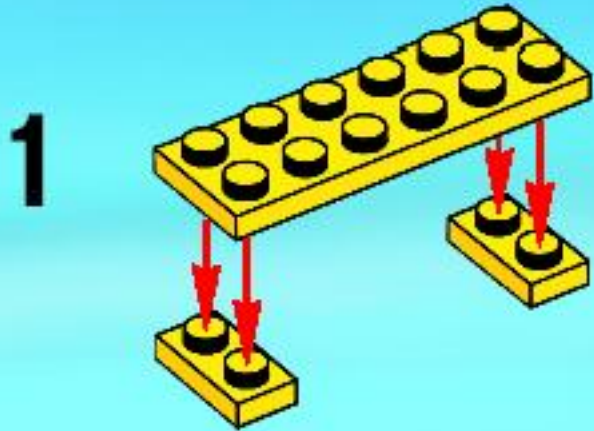

4

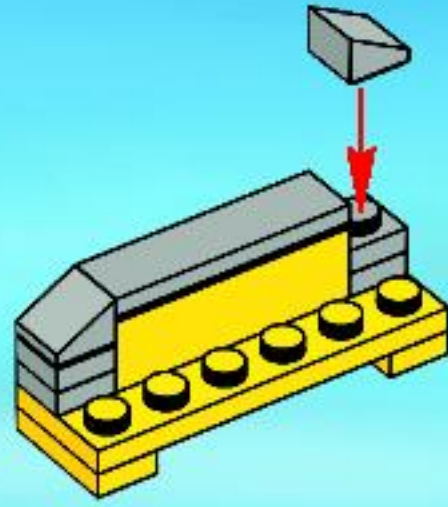

5

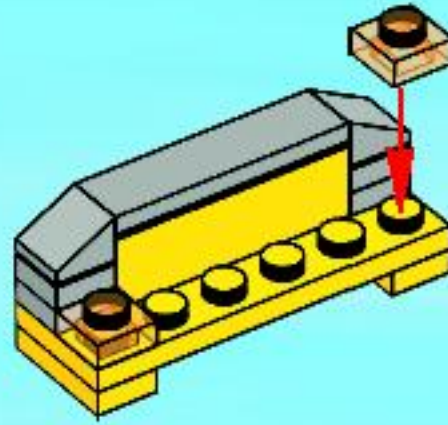

6



7

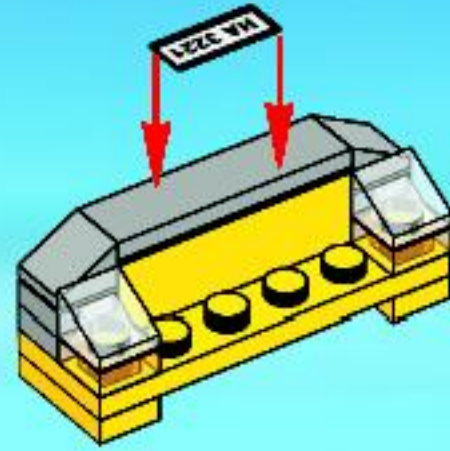

14

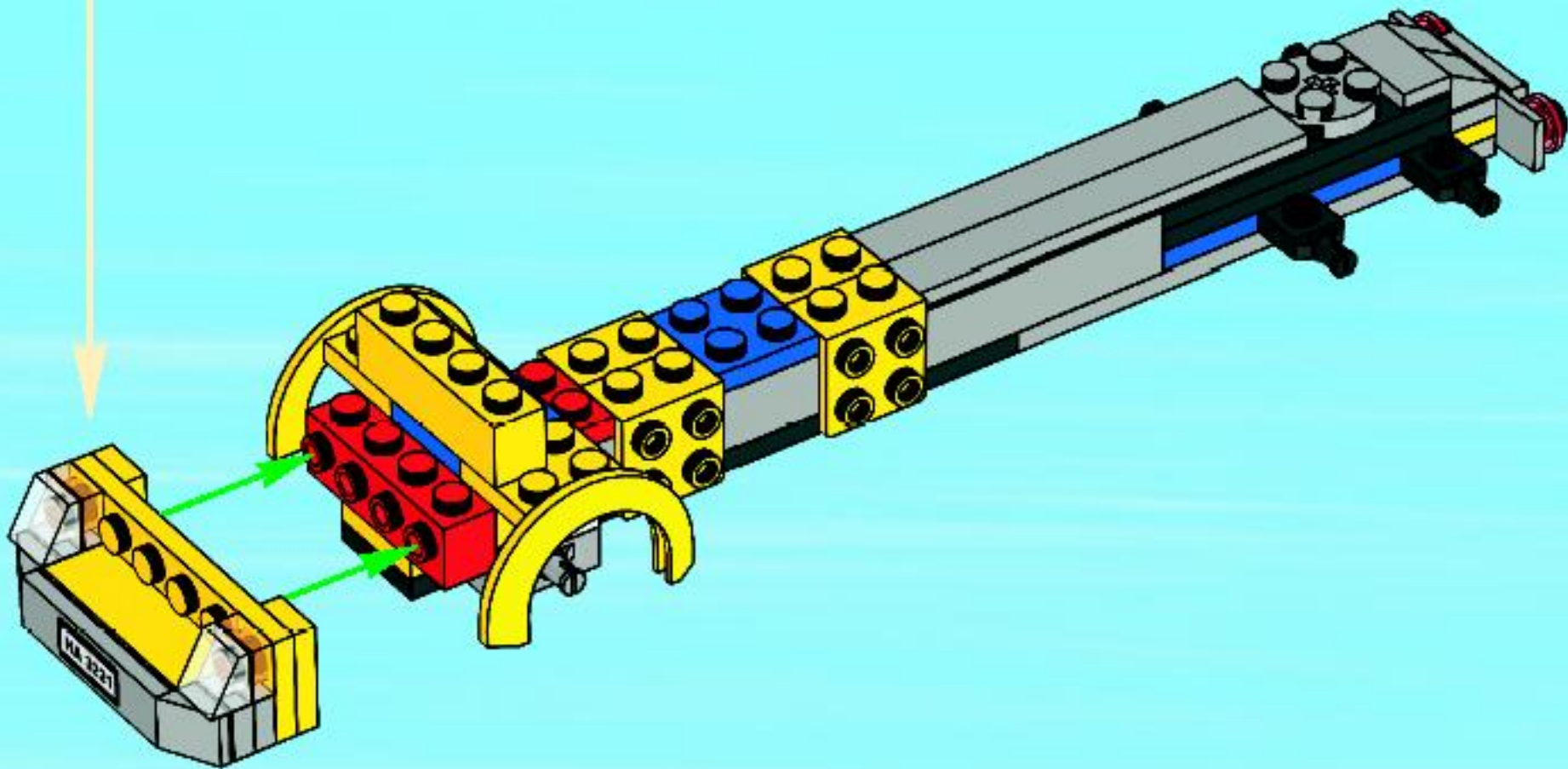

15

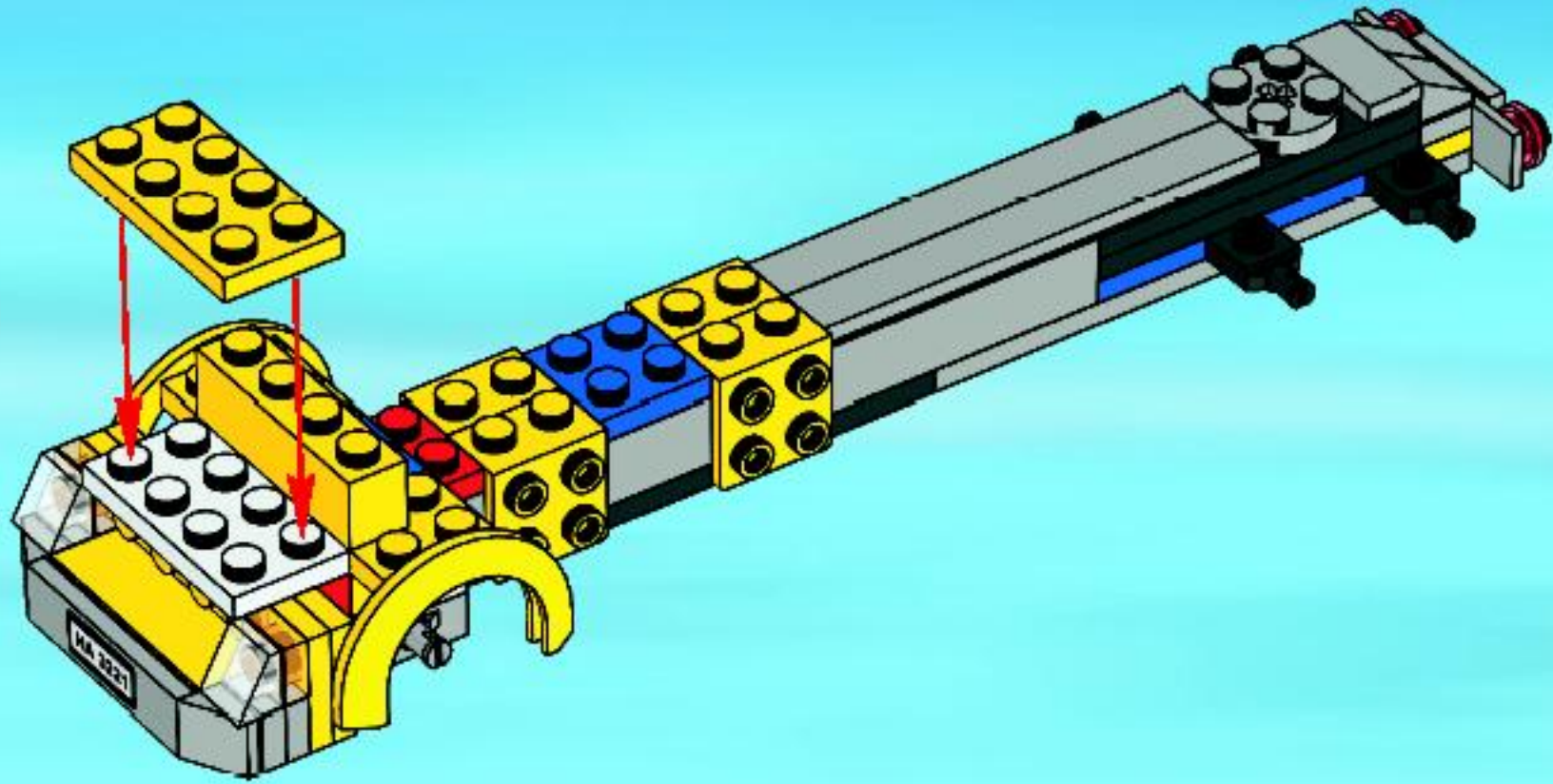

16

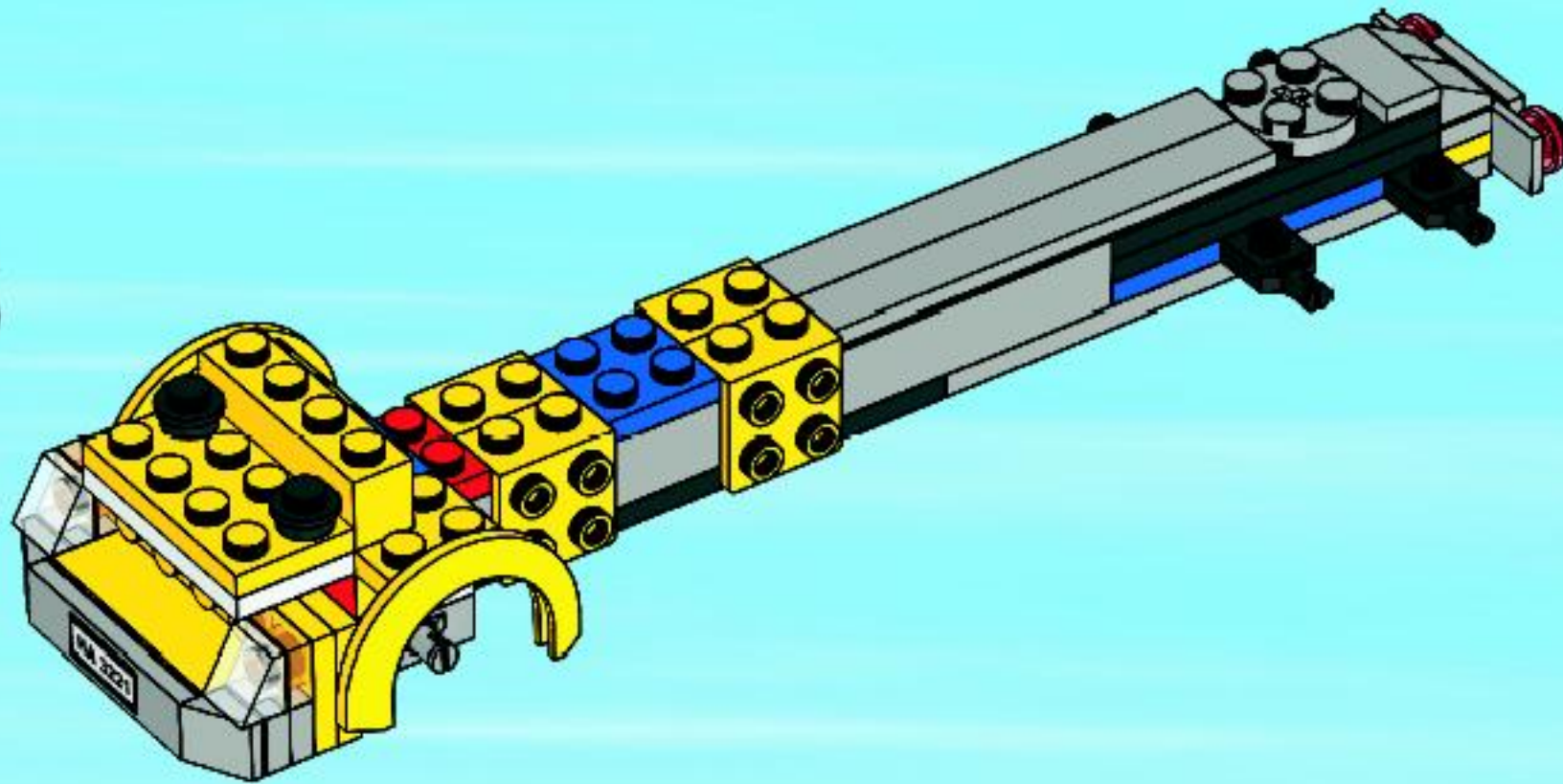

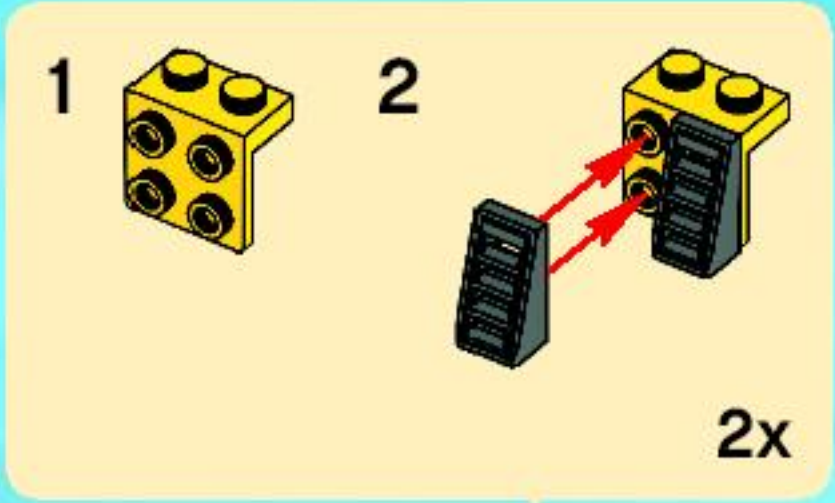

17

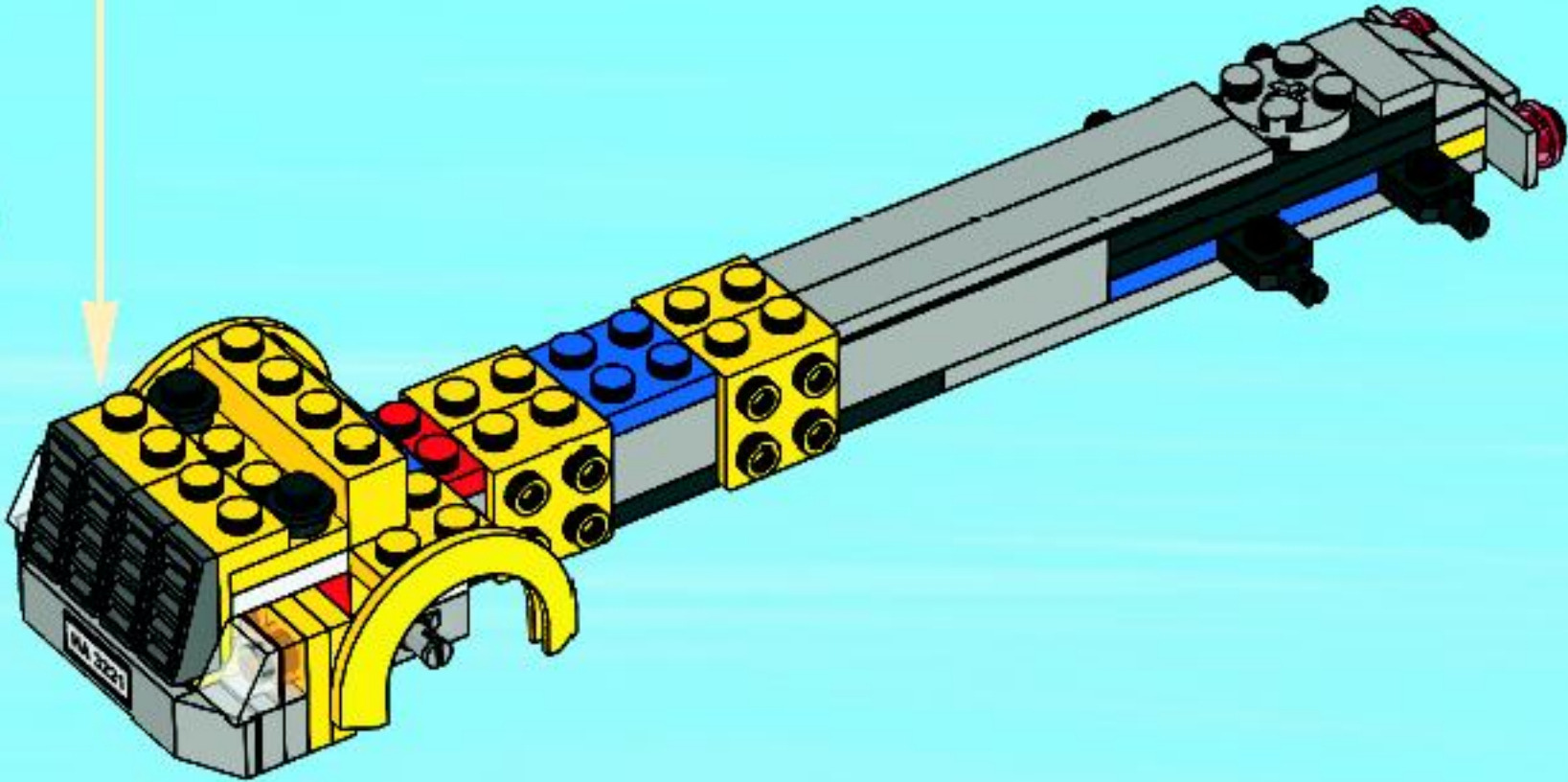

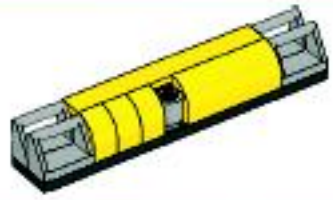

2x

1



2

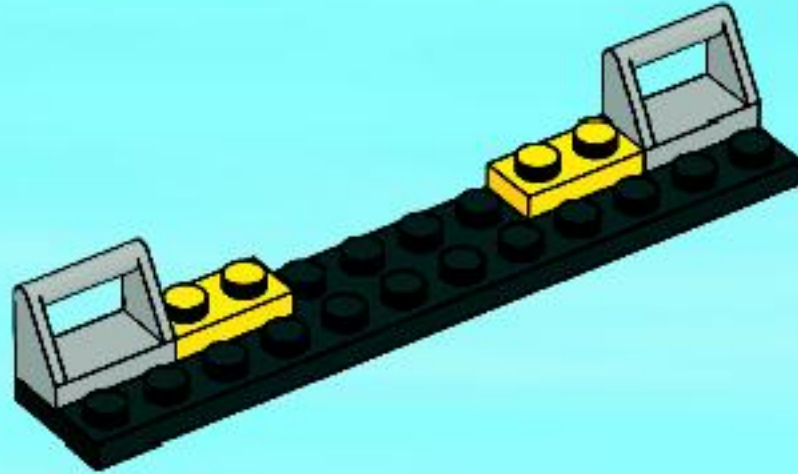

3

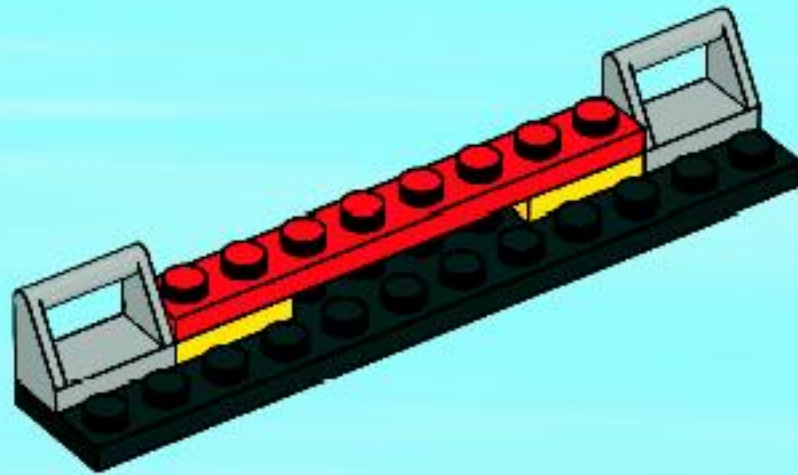

4

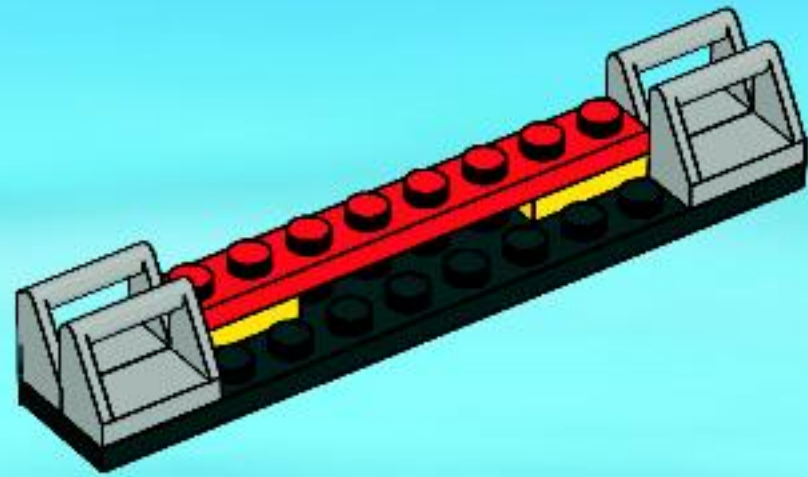

5

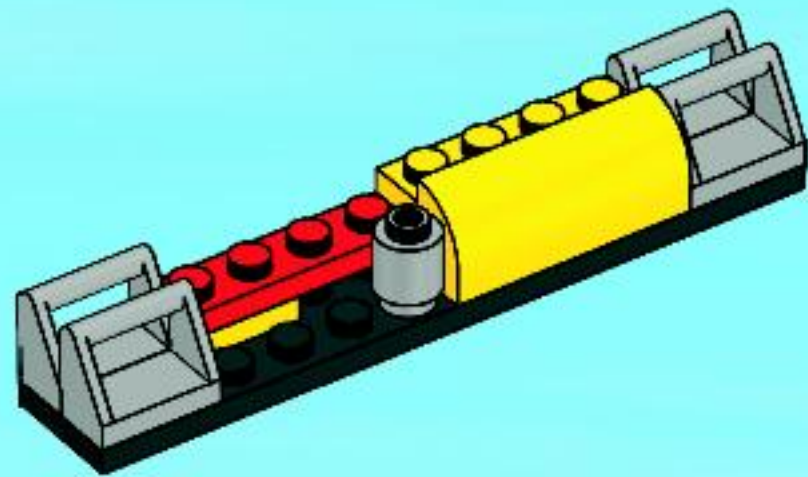

6

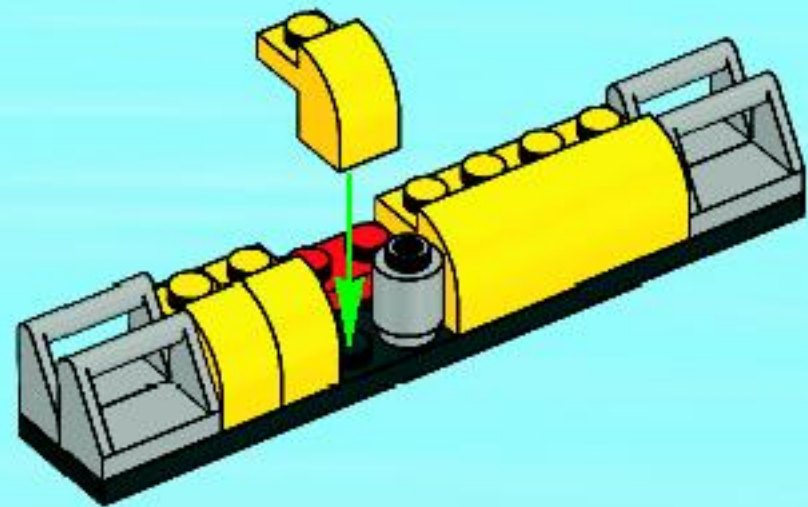

7

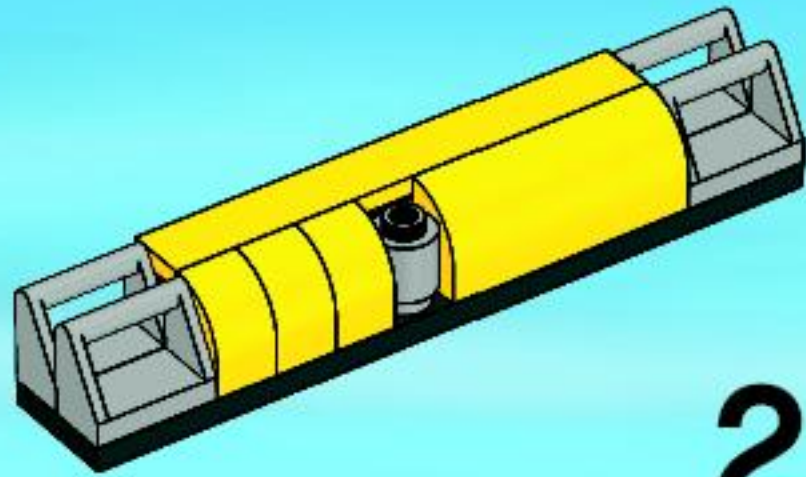

2x

18

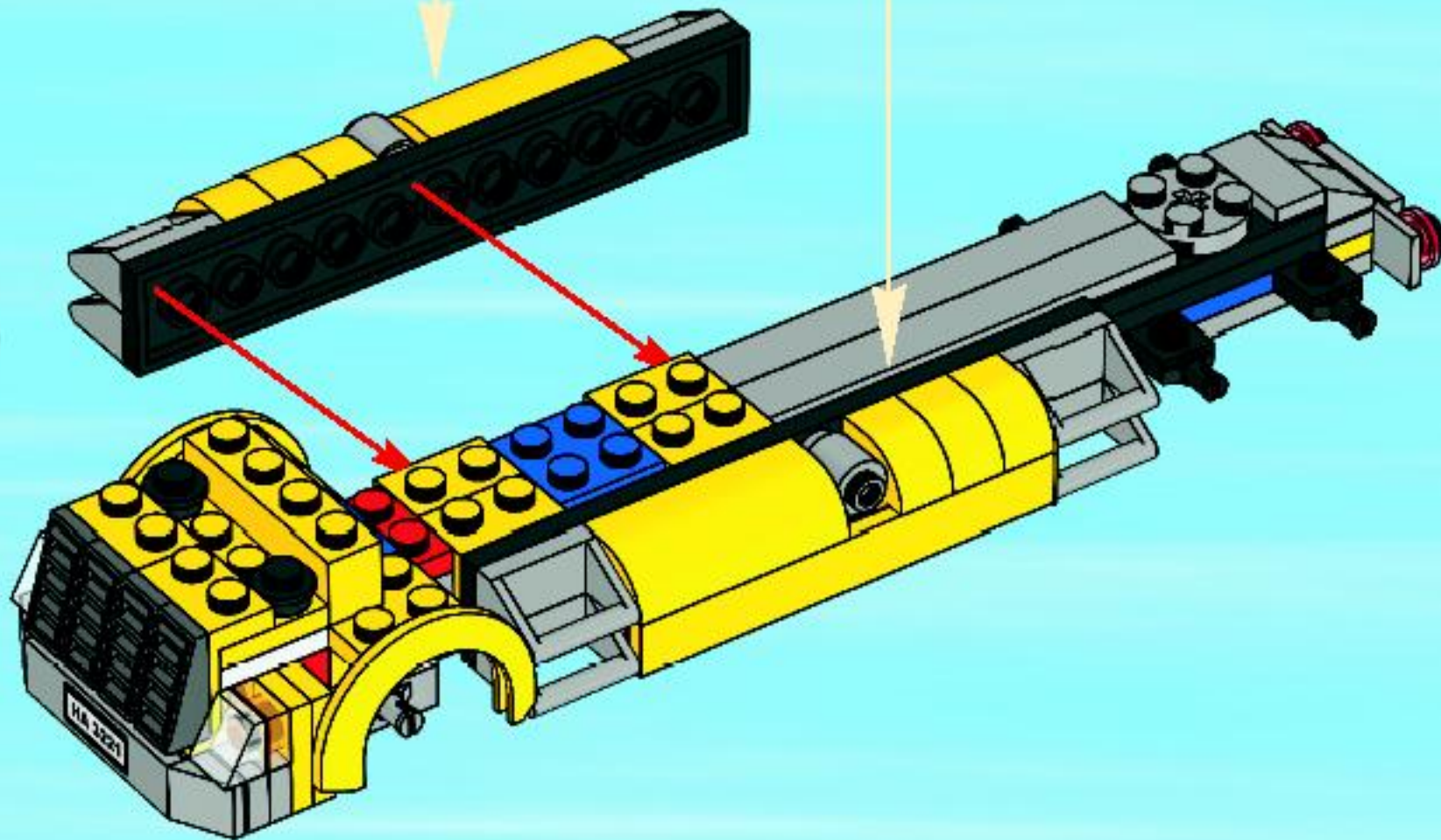

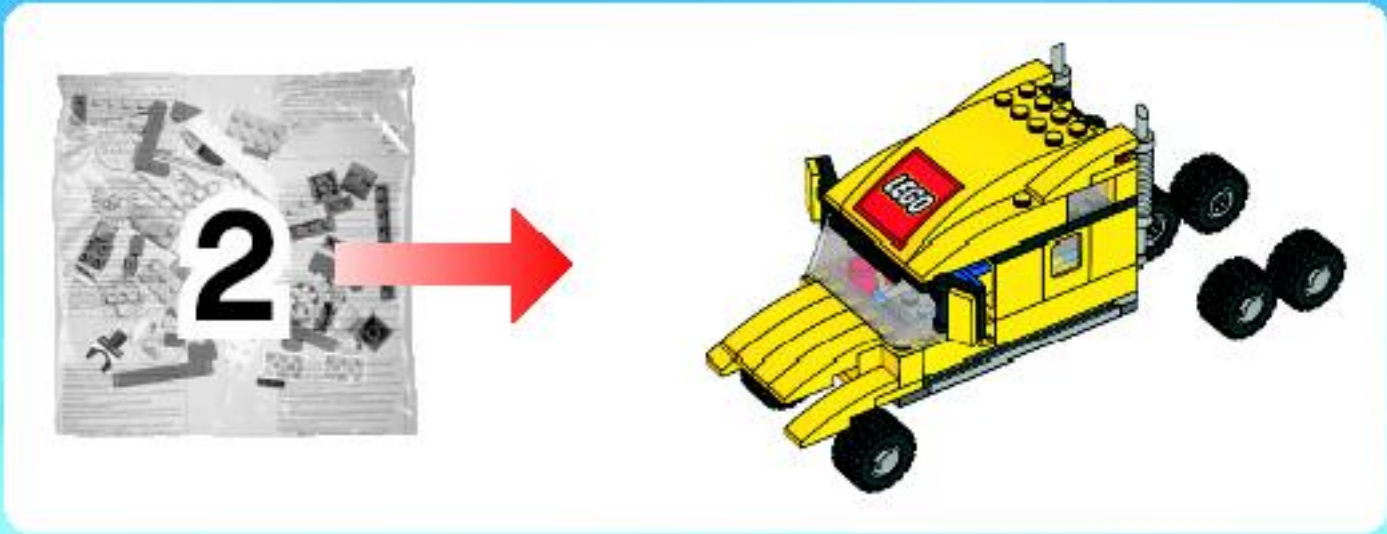

1

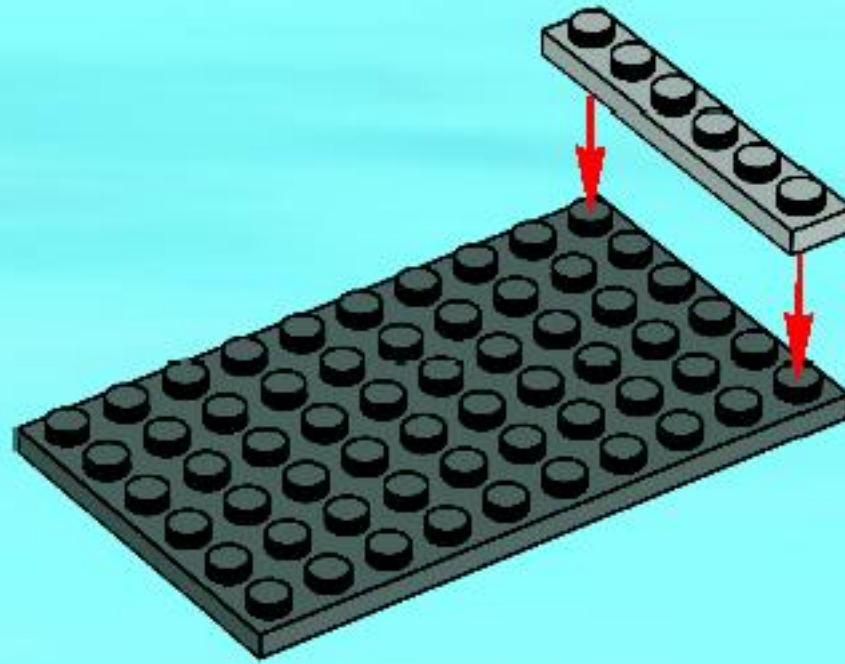

2

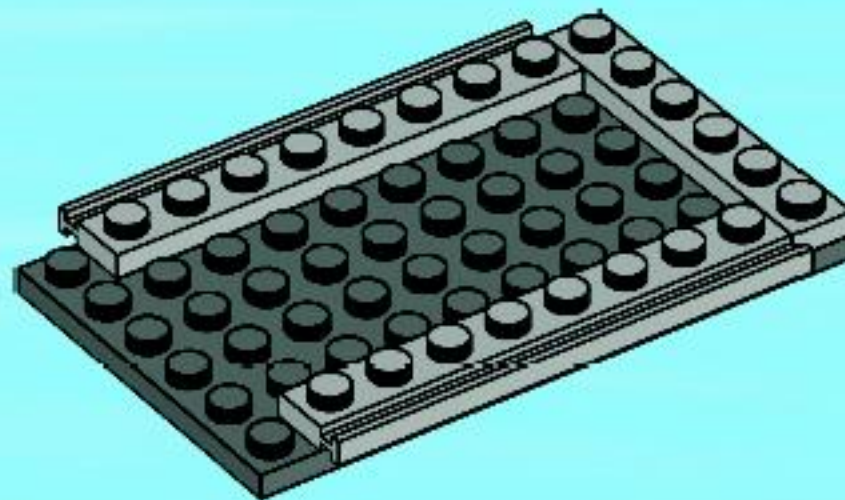

3

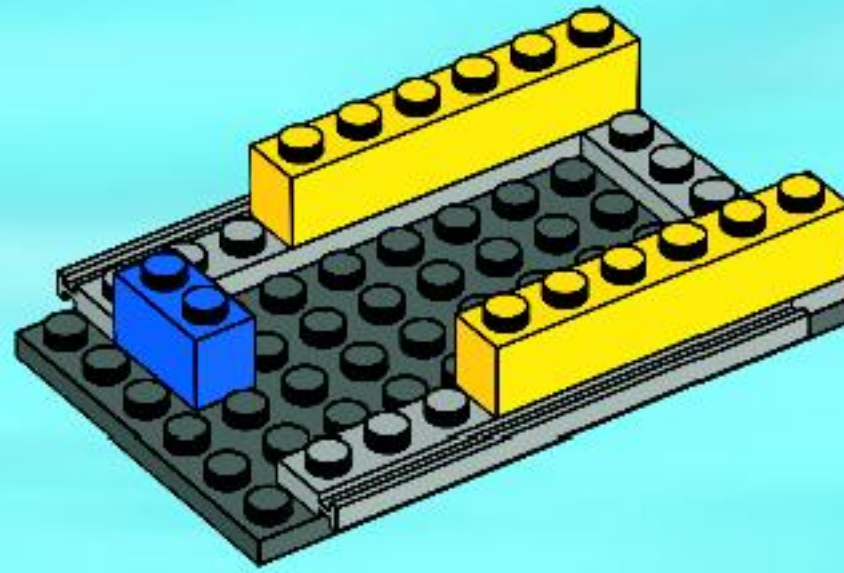

4

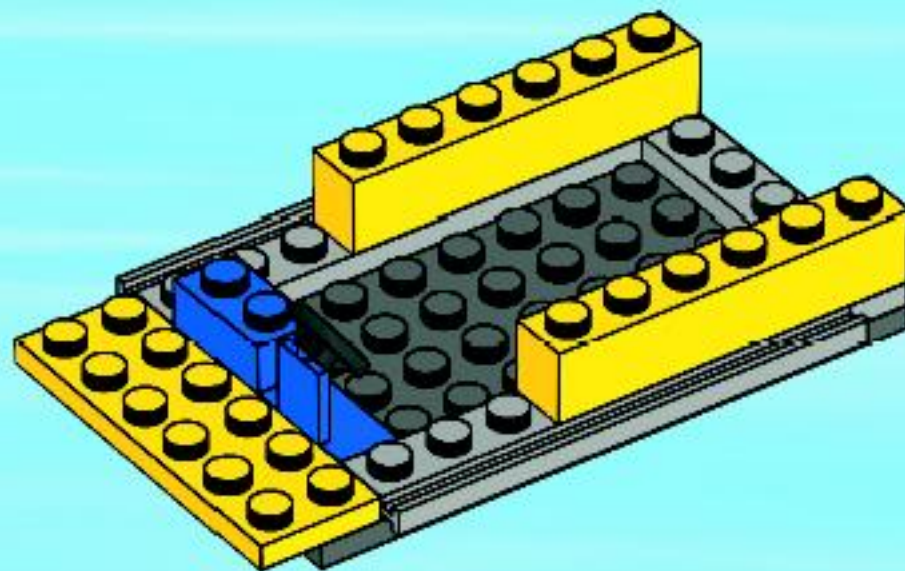

5

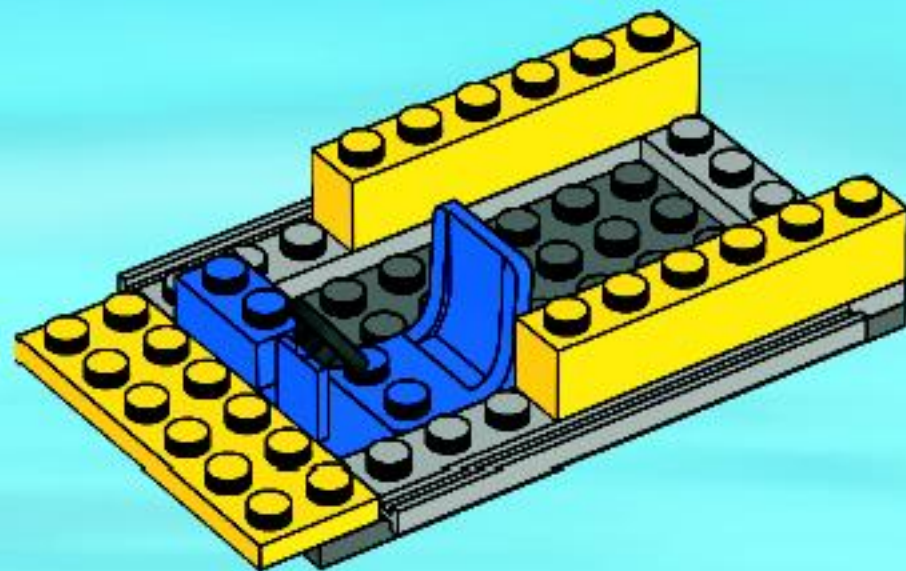

6

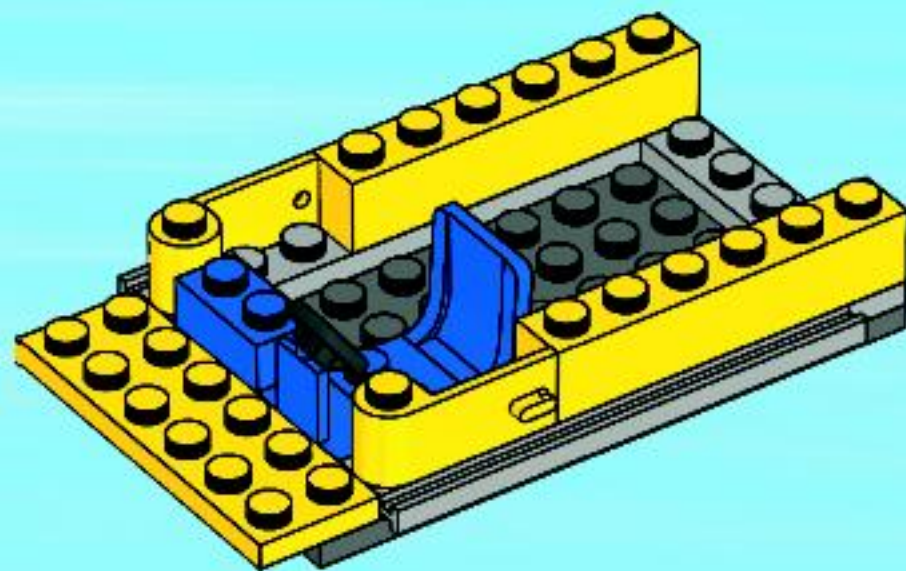

7

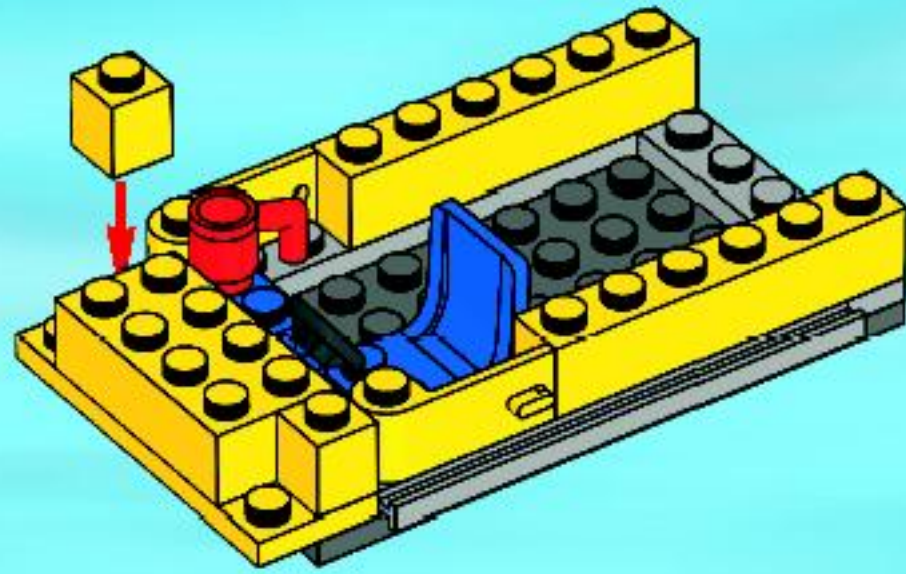

8

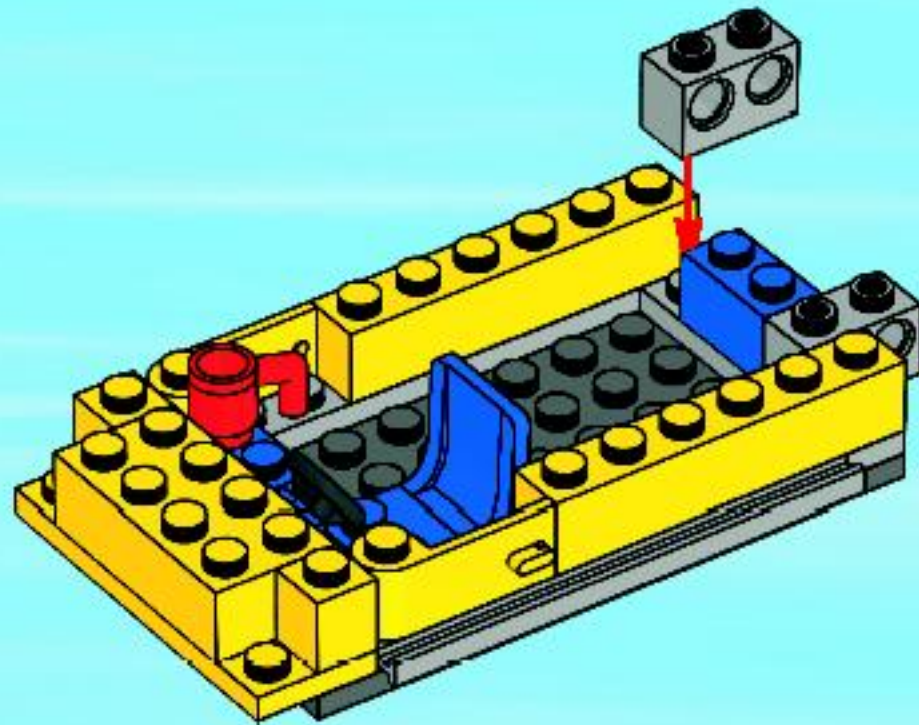

9

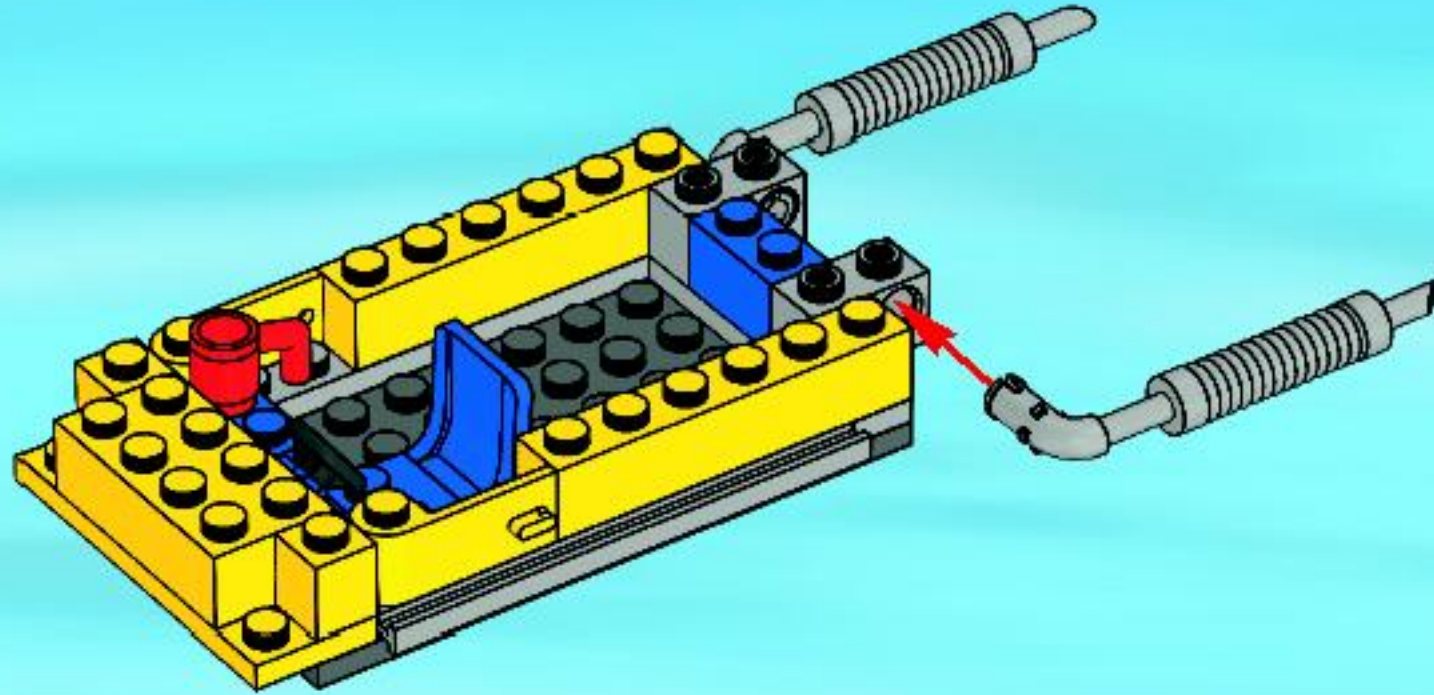

10

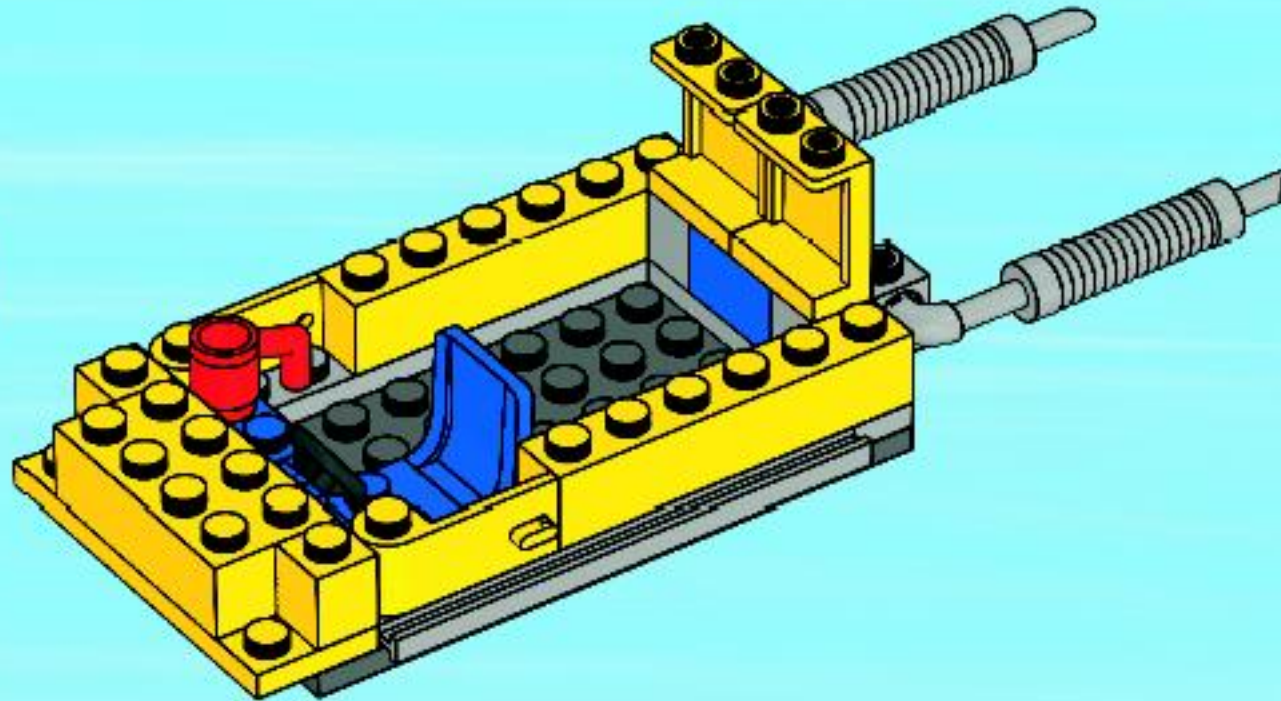

11

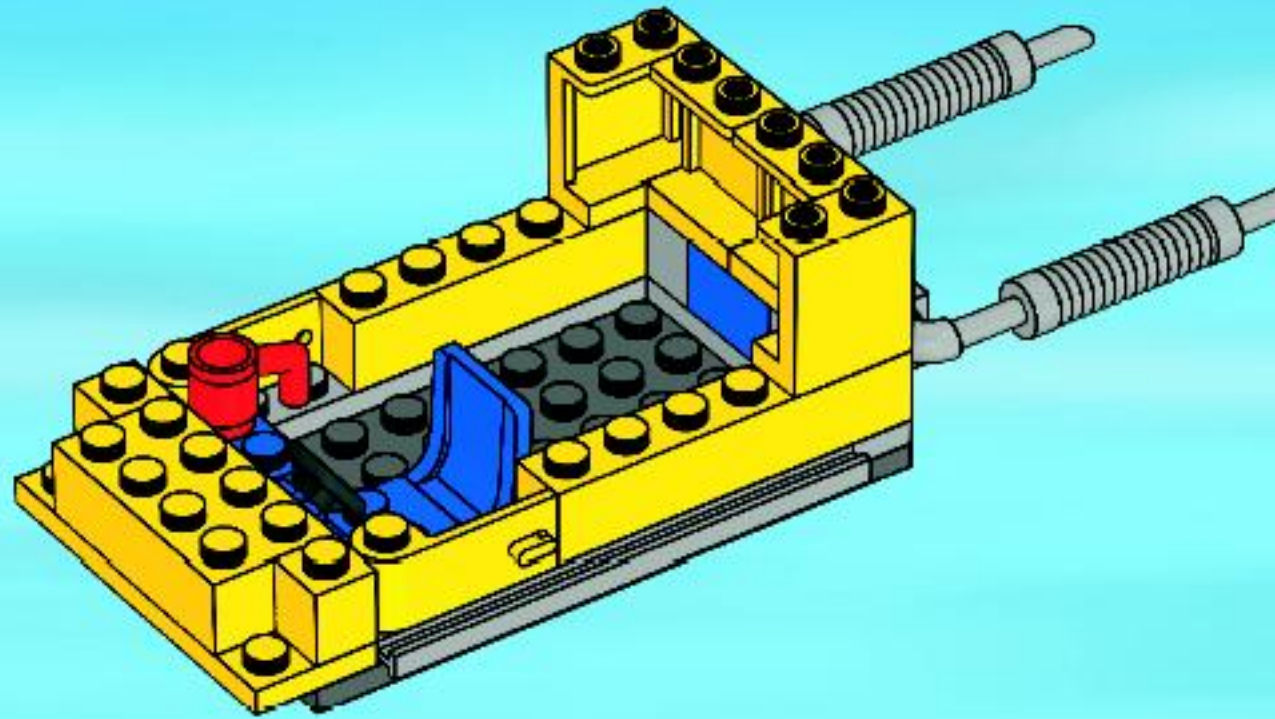

1

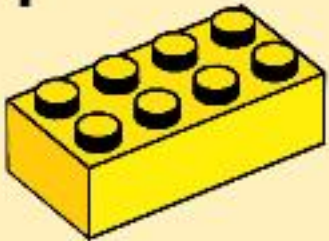

2

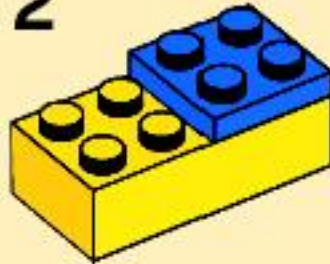

3

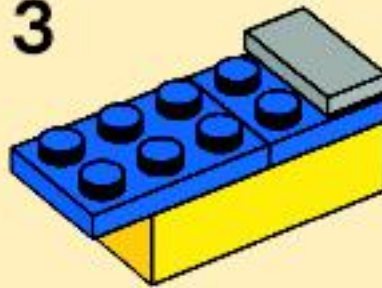

12

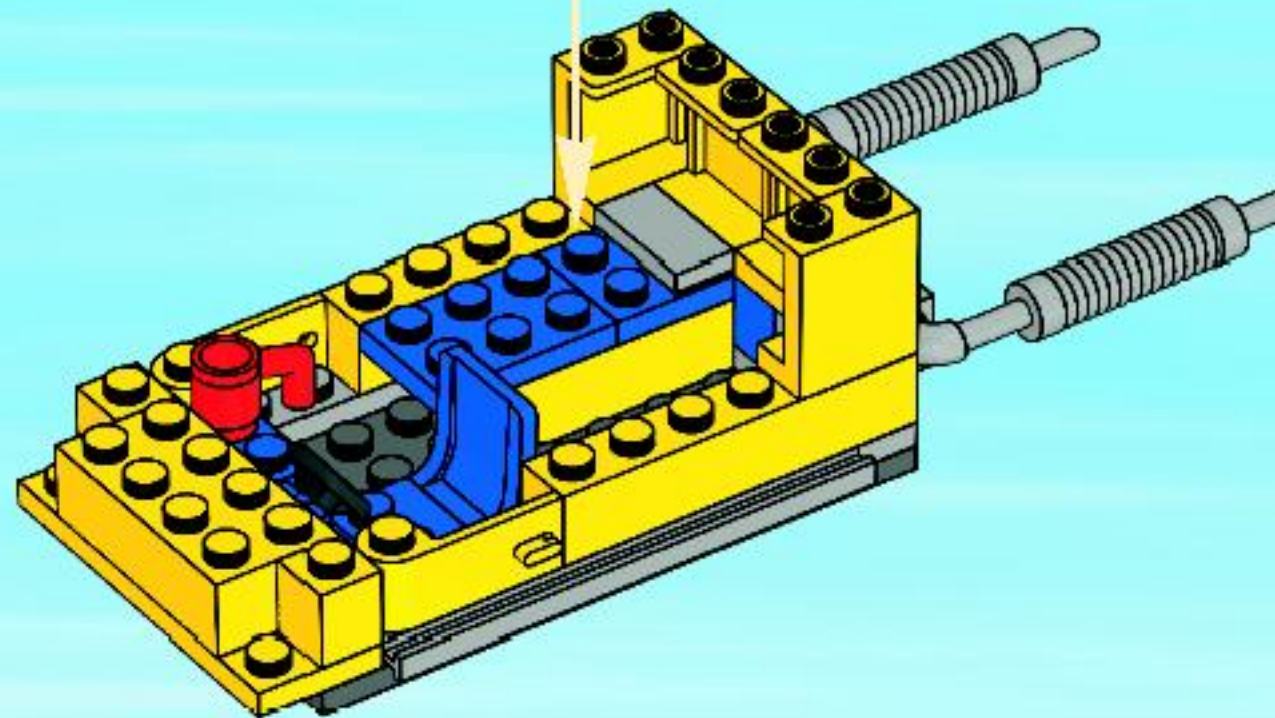

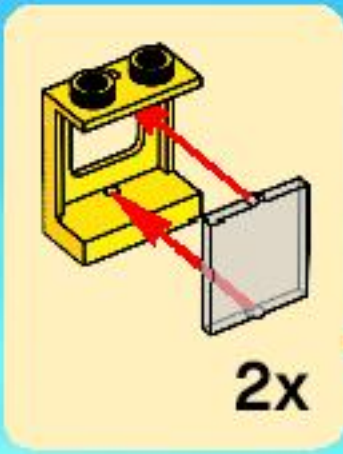

13

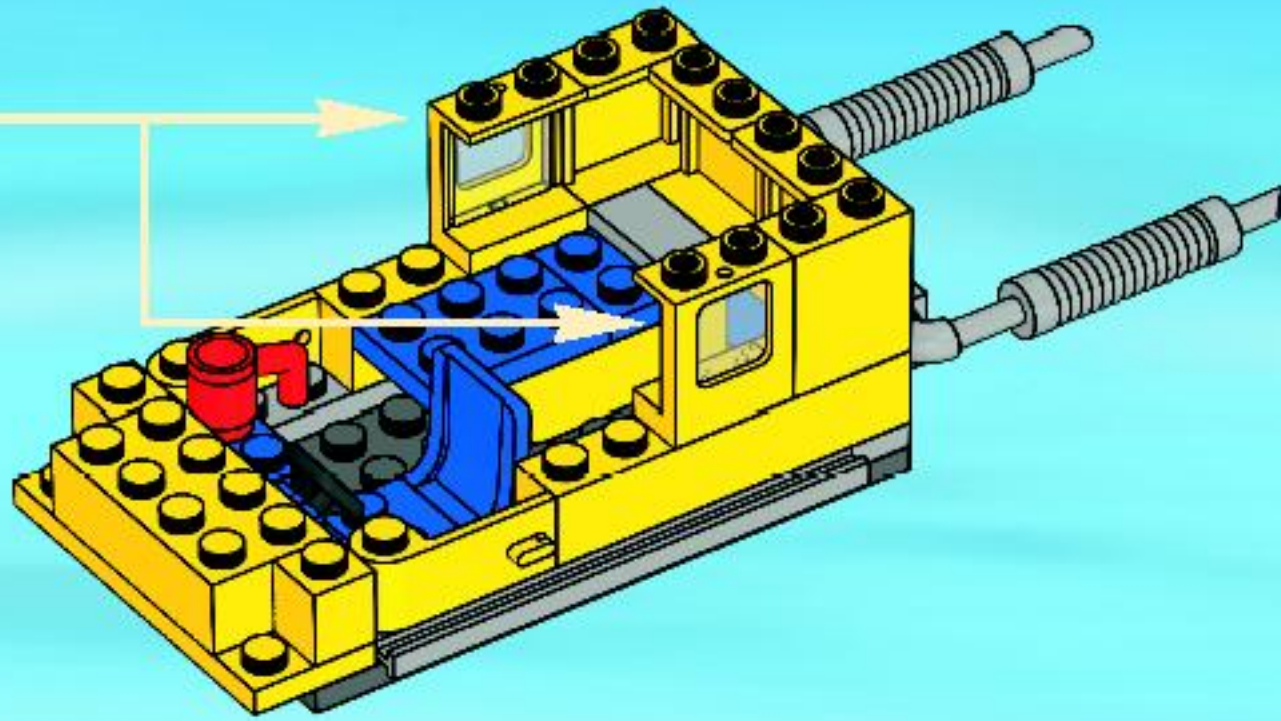

14

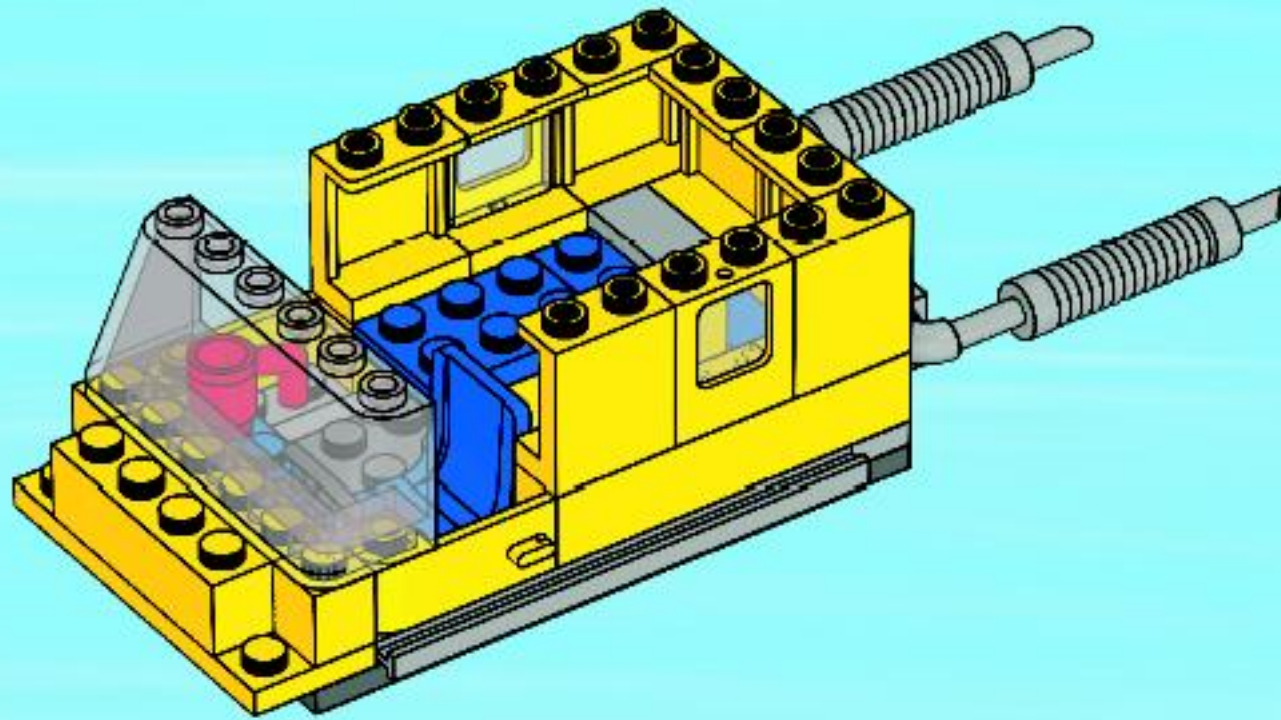

15

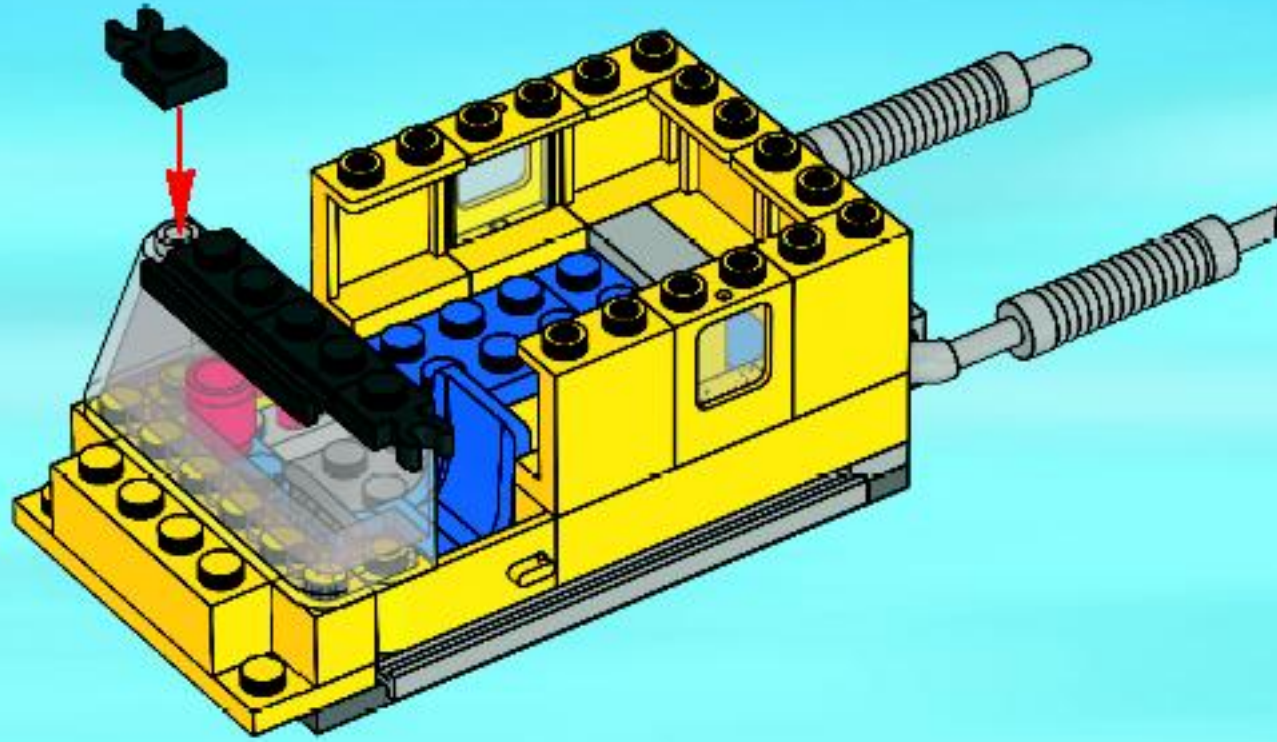

16

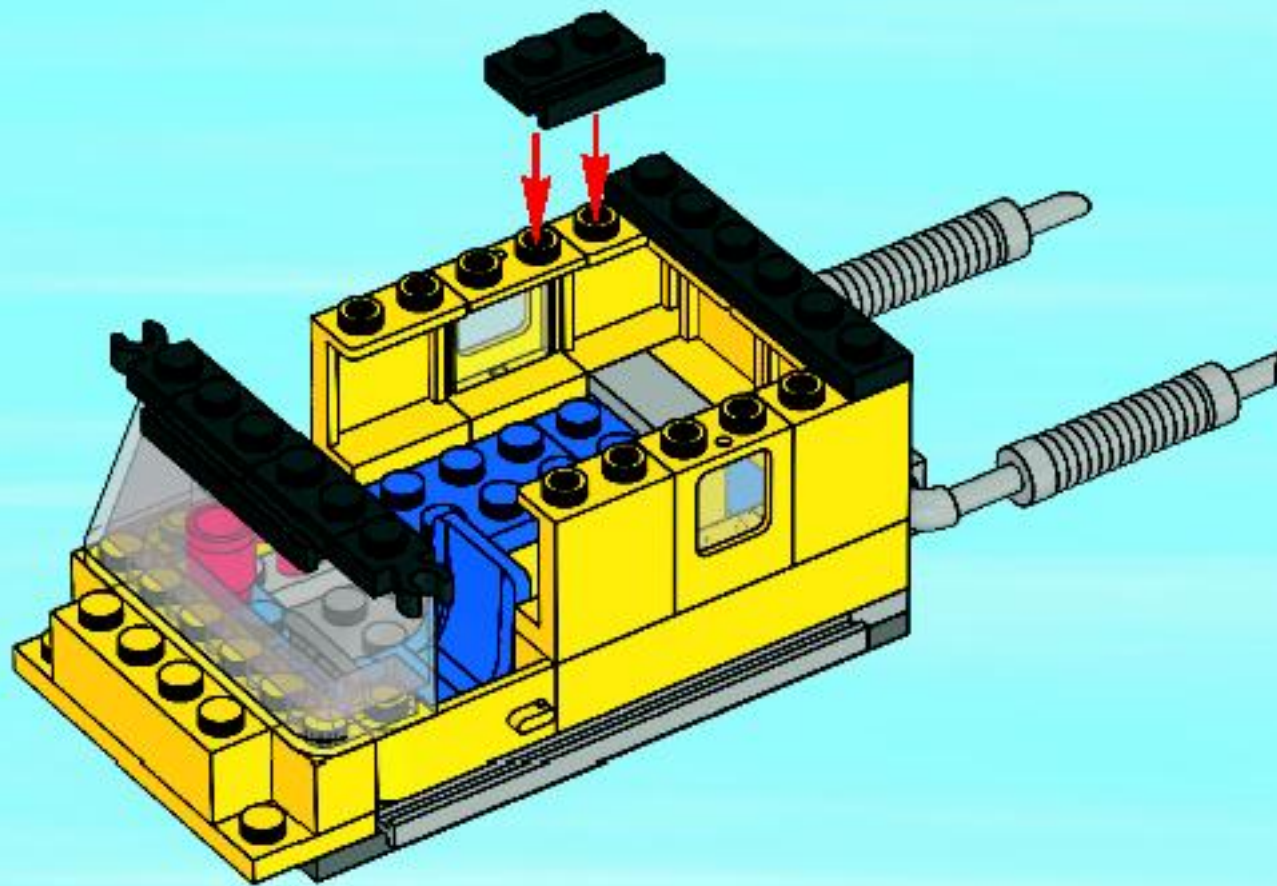

17

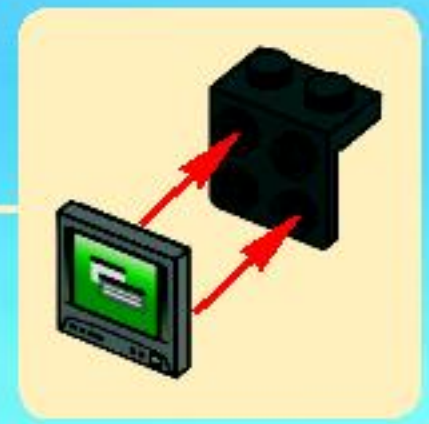
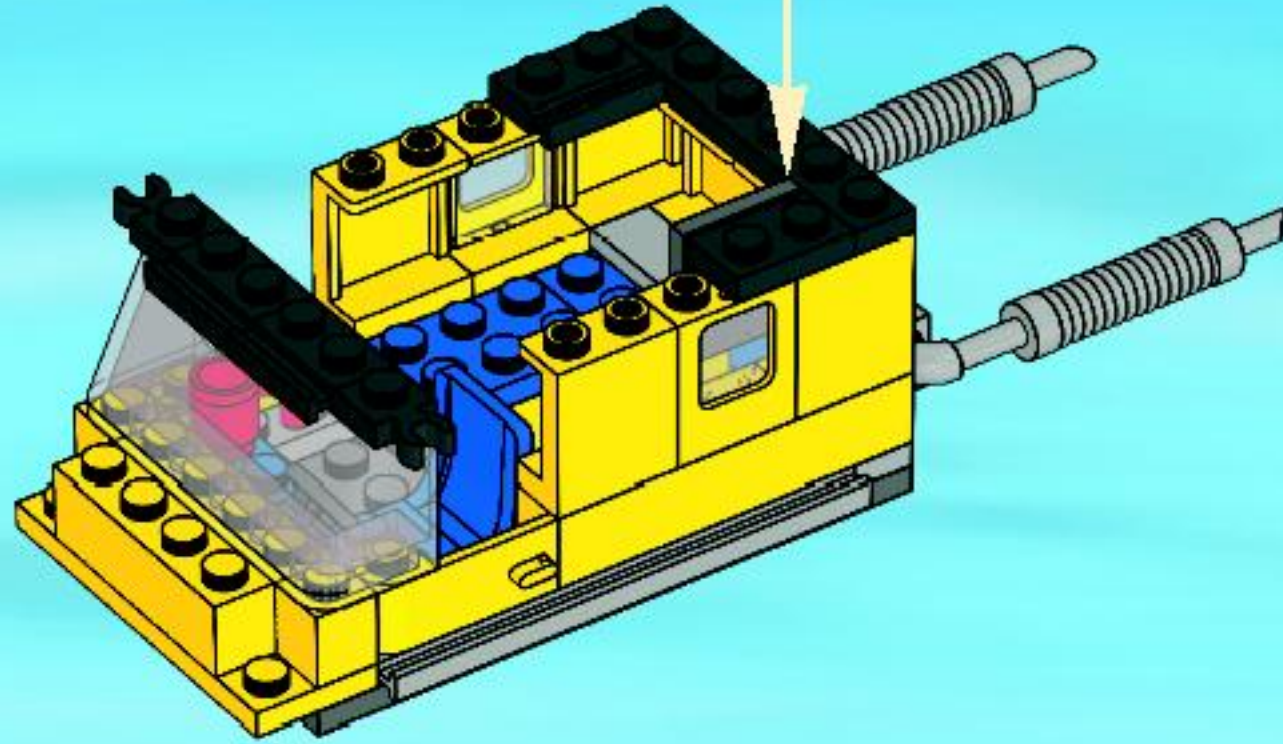

18

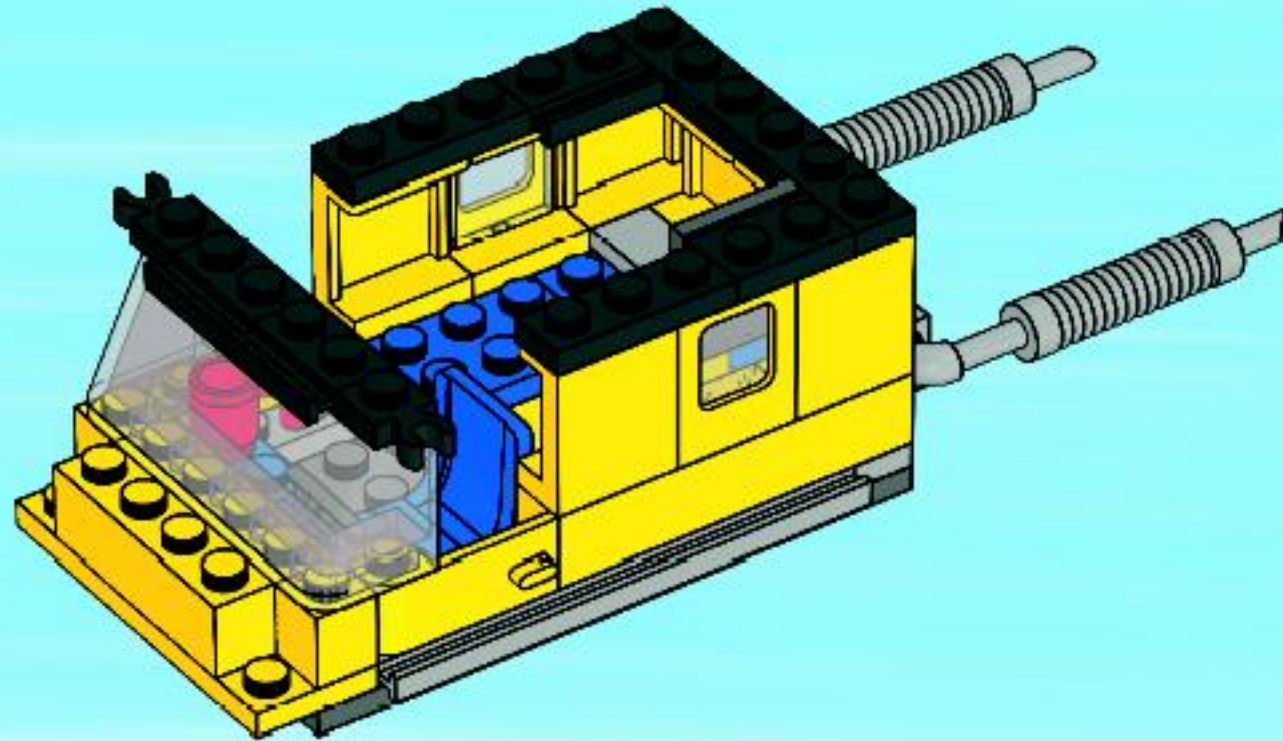

19

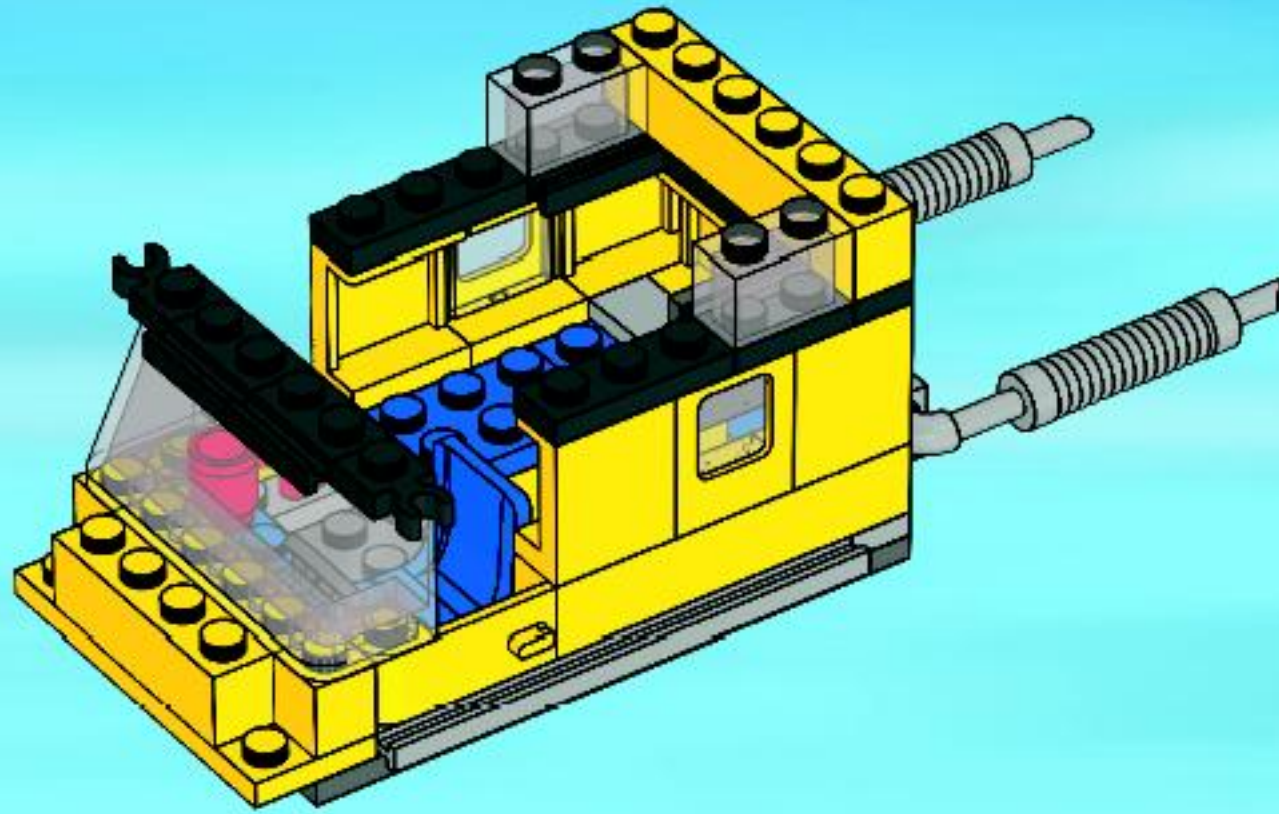

20

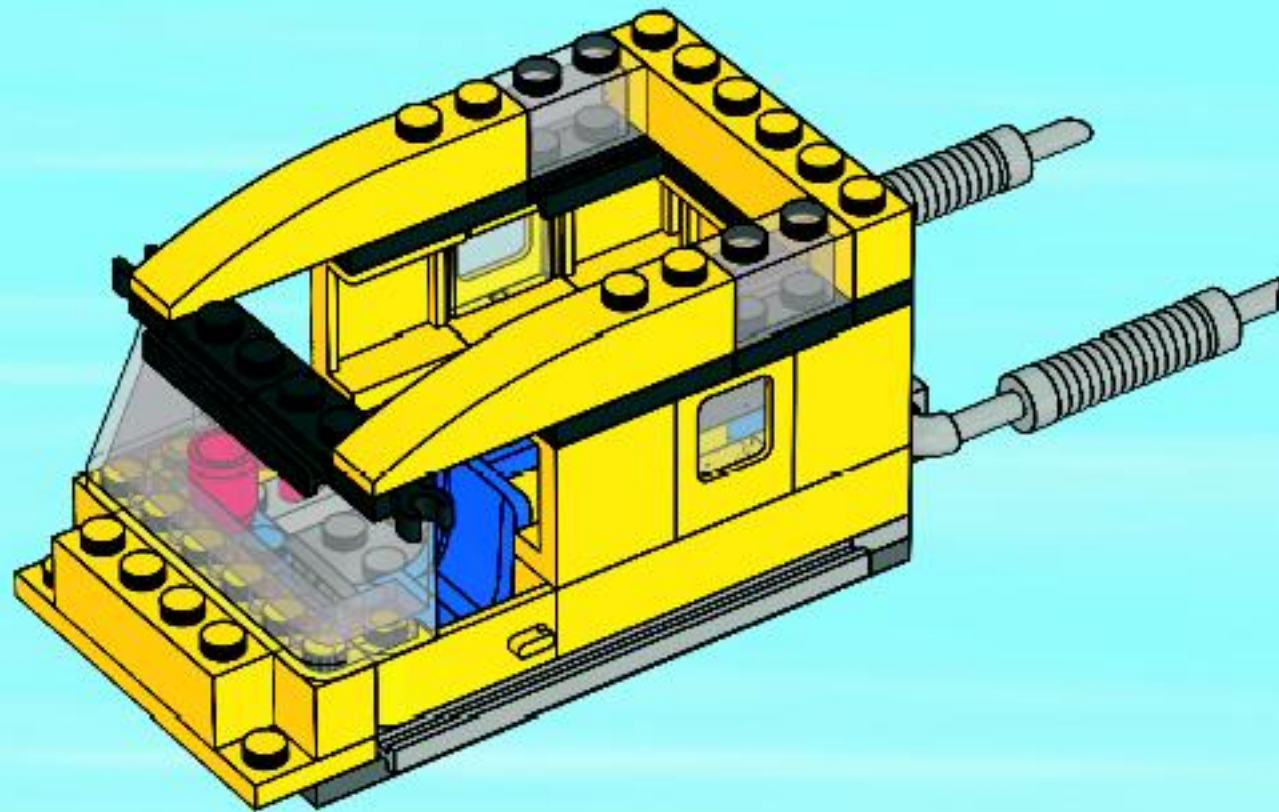

21

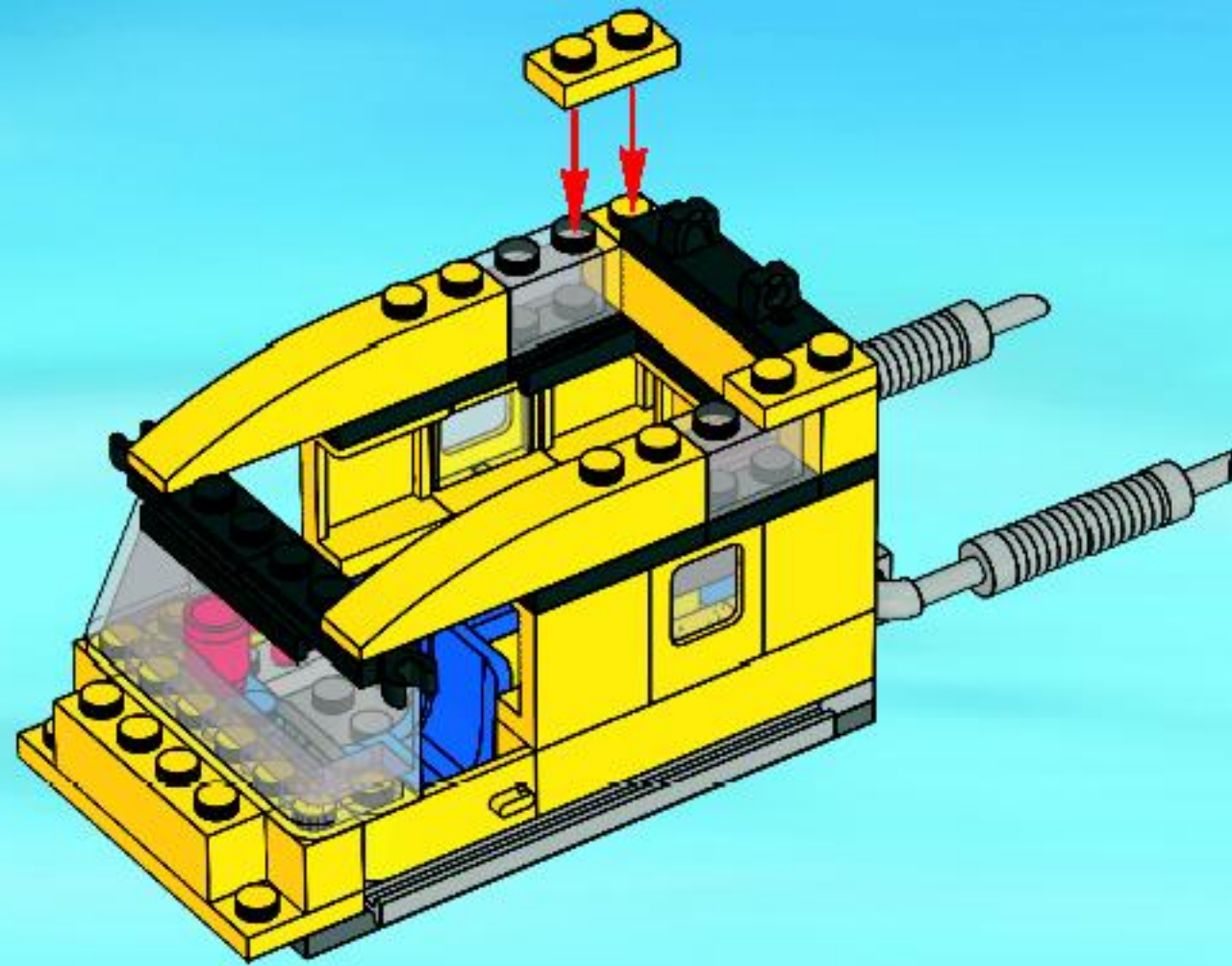

22

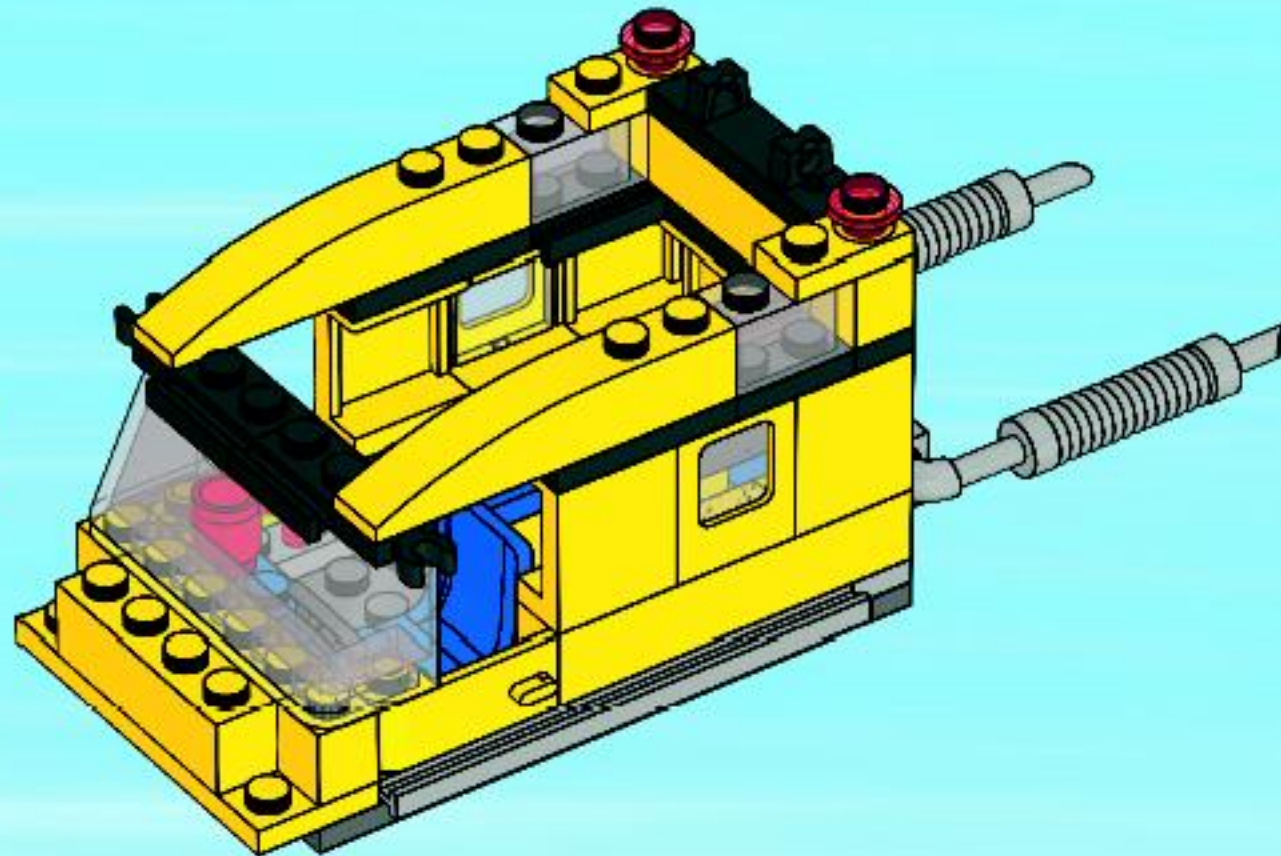

23

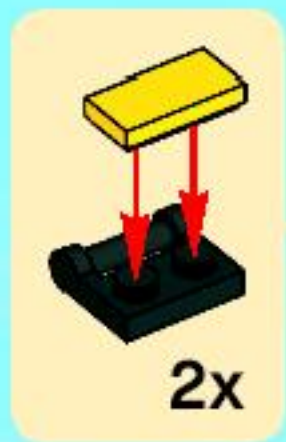
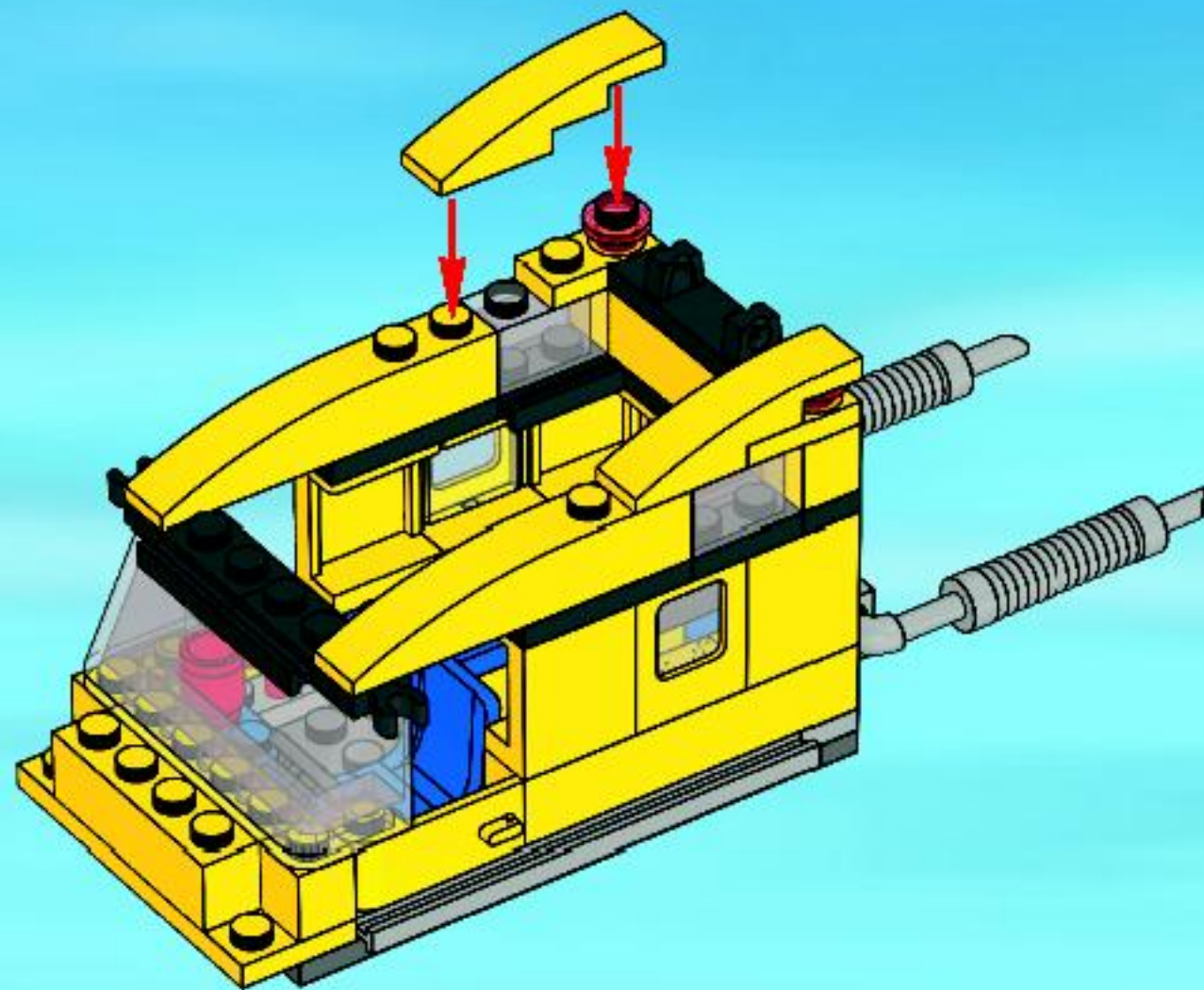

24

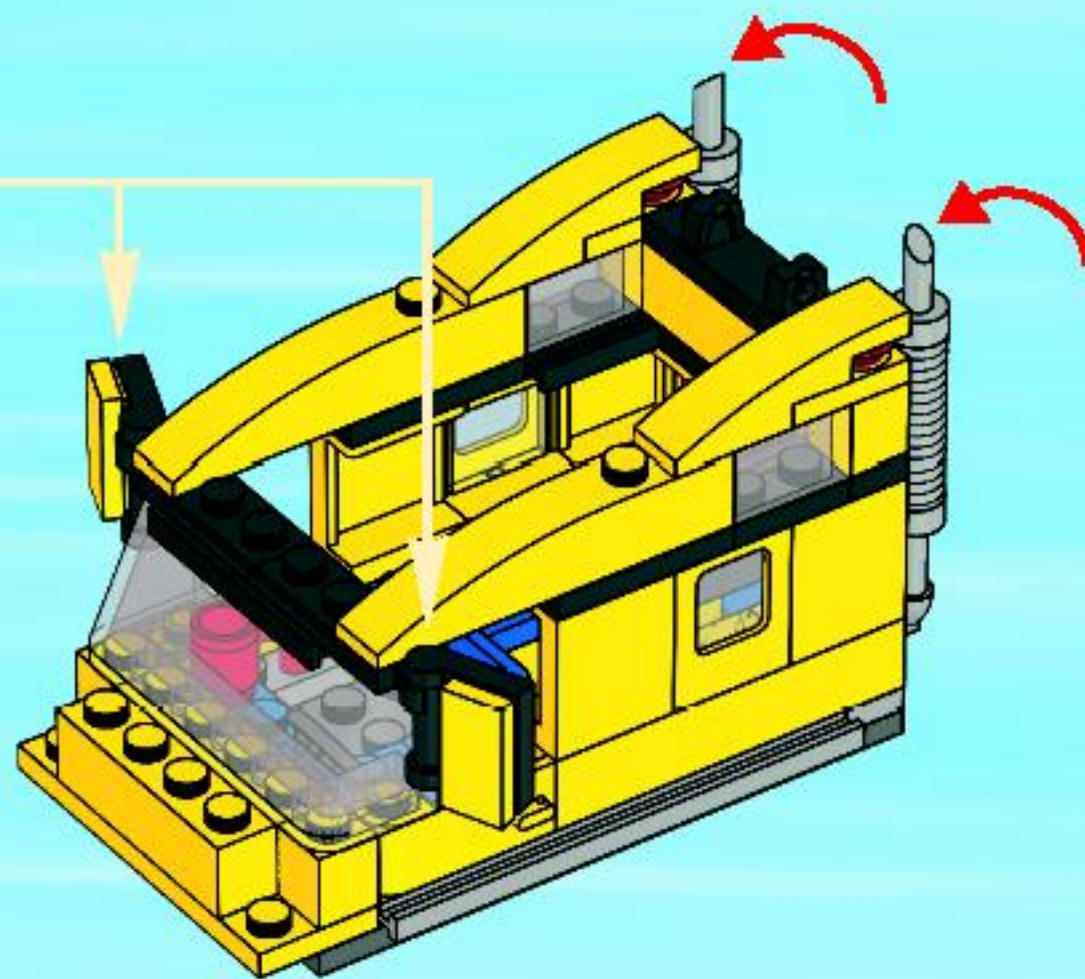



25

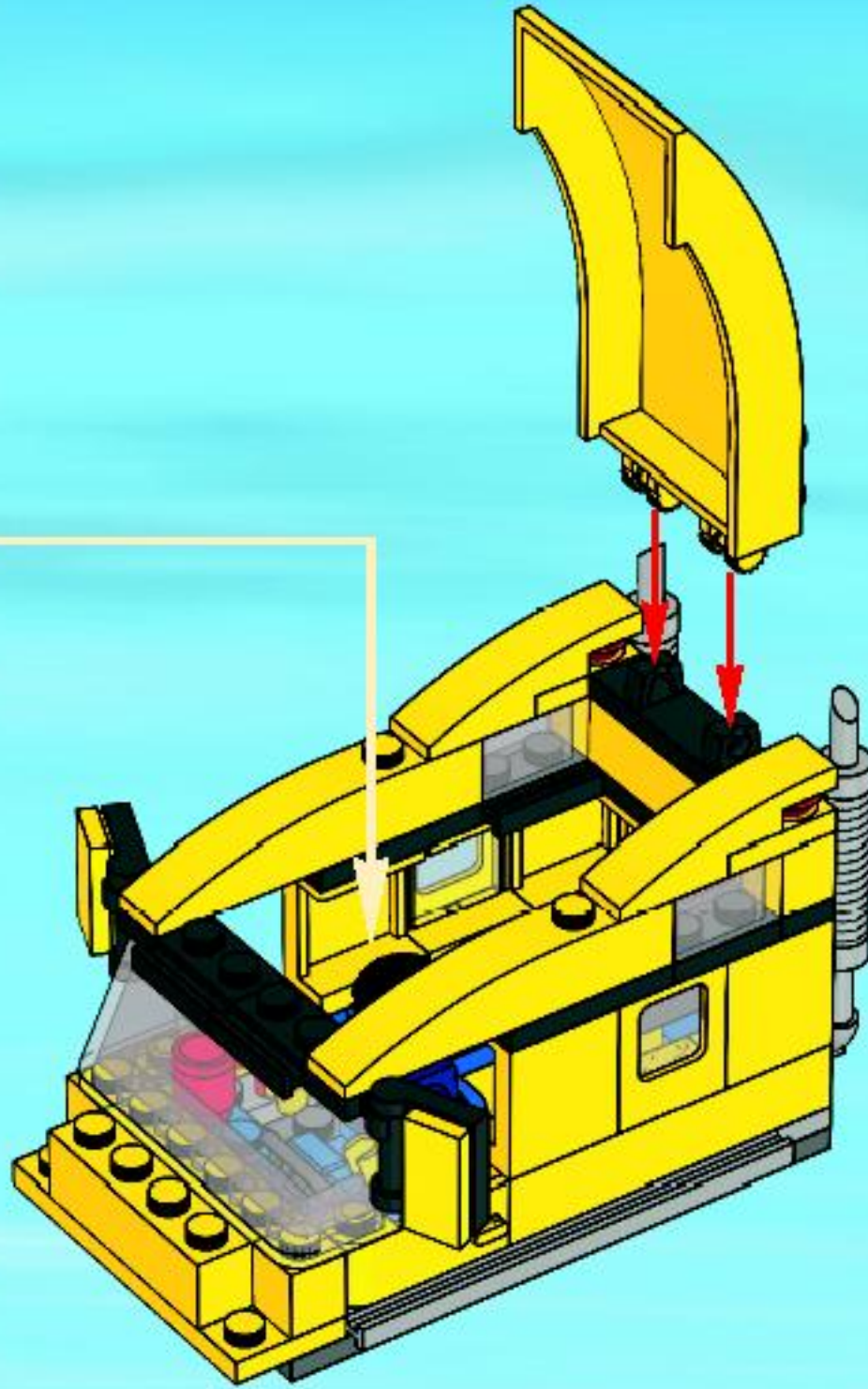

26

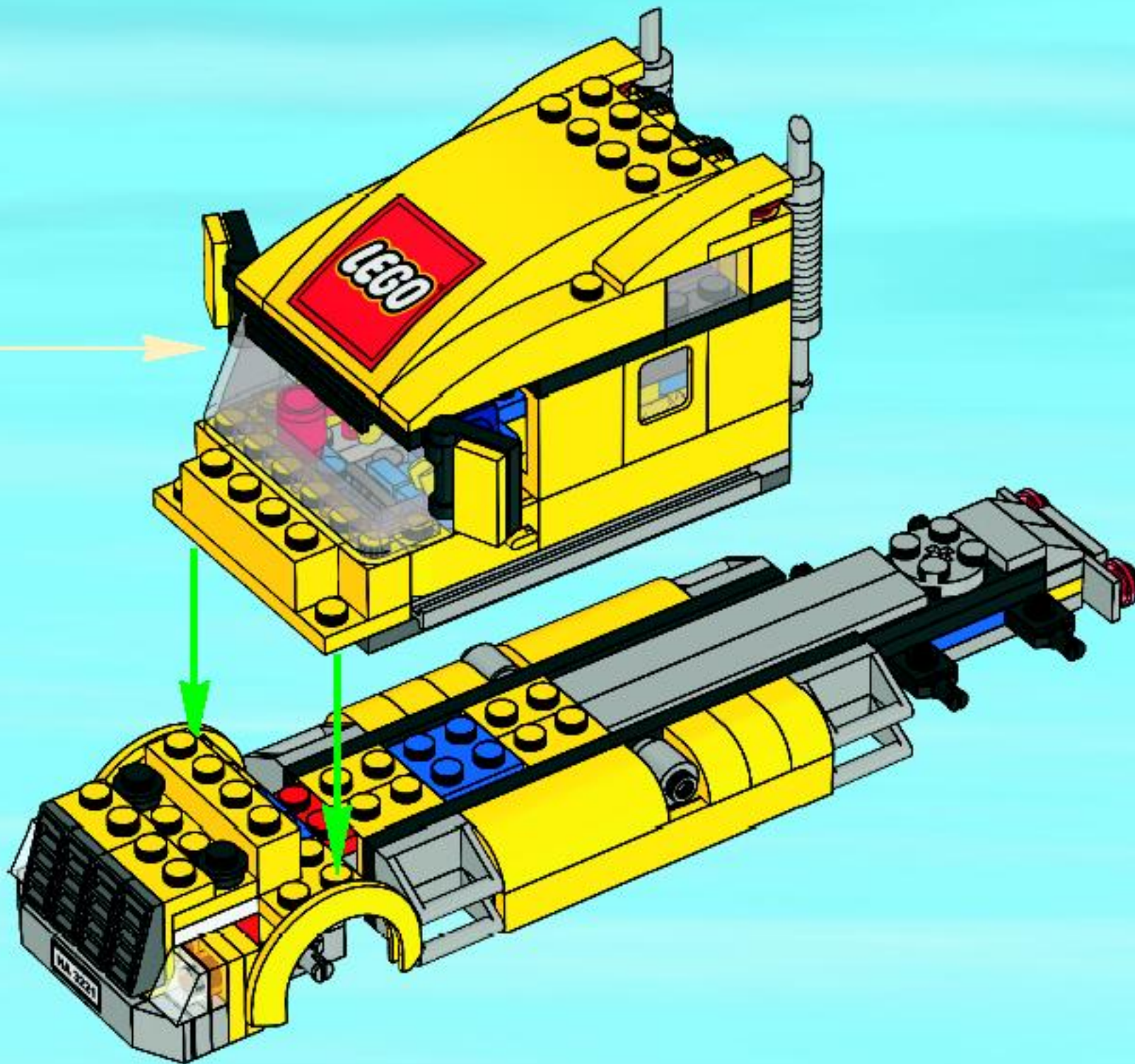

27

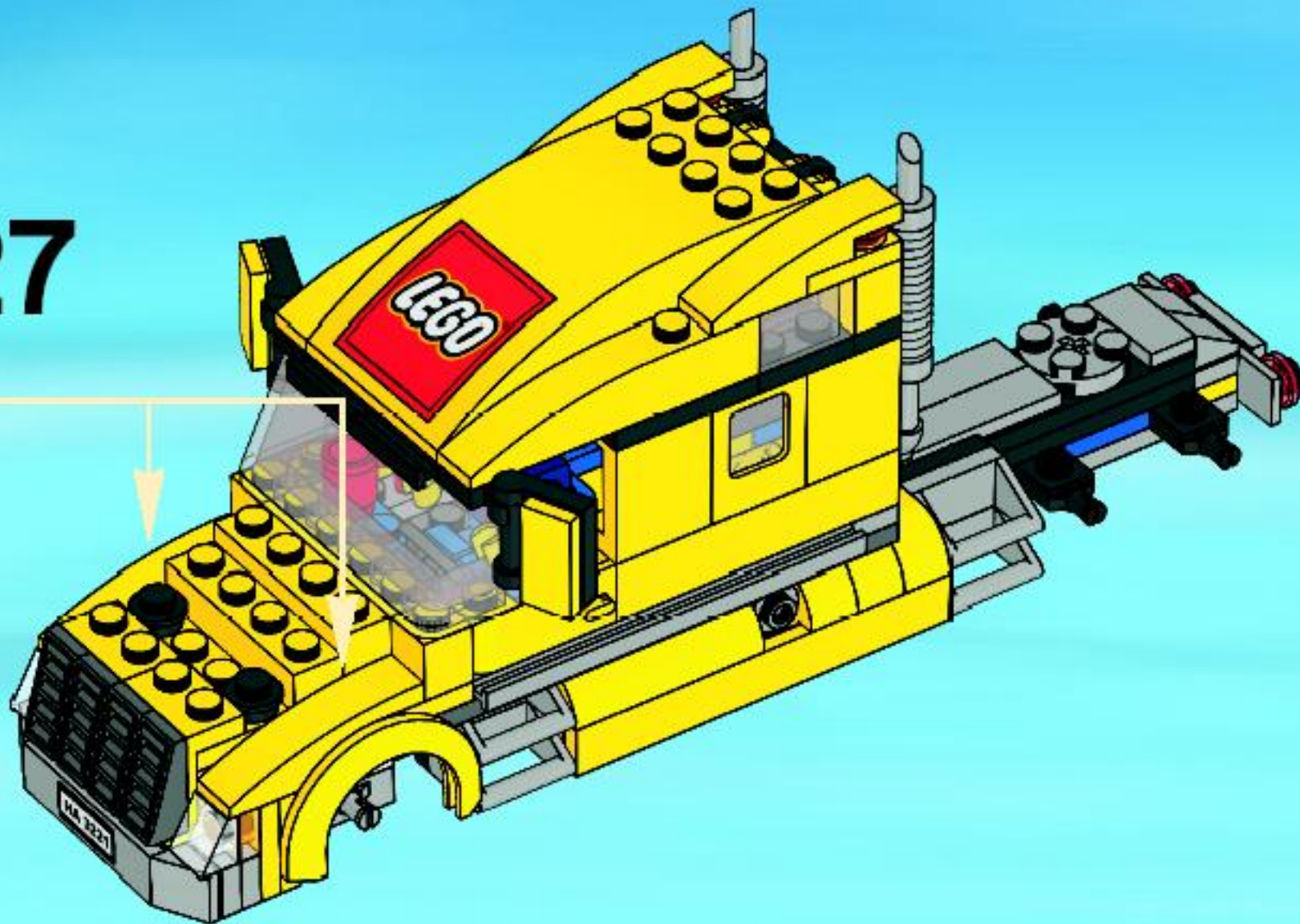
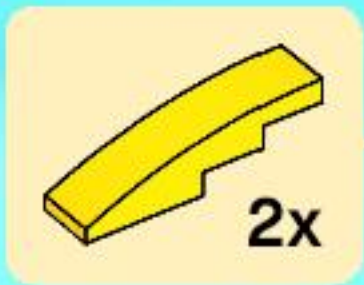

28

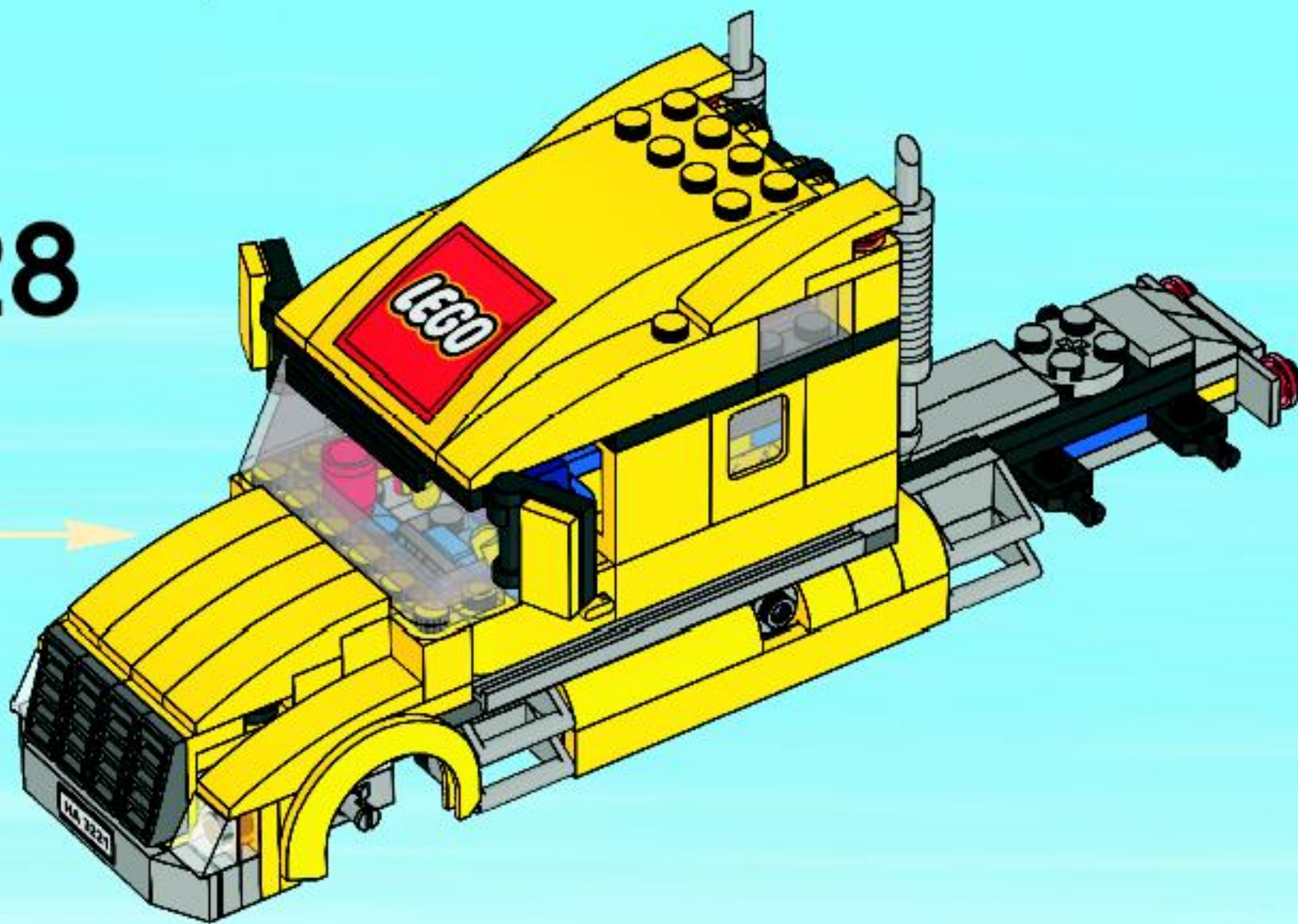
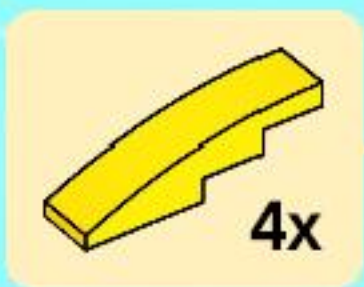

29



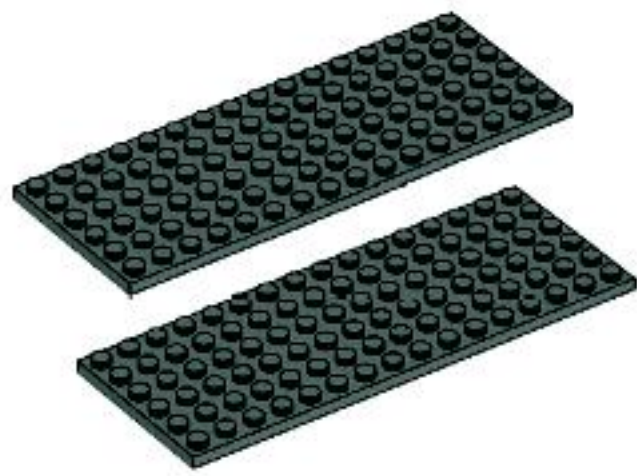

+

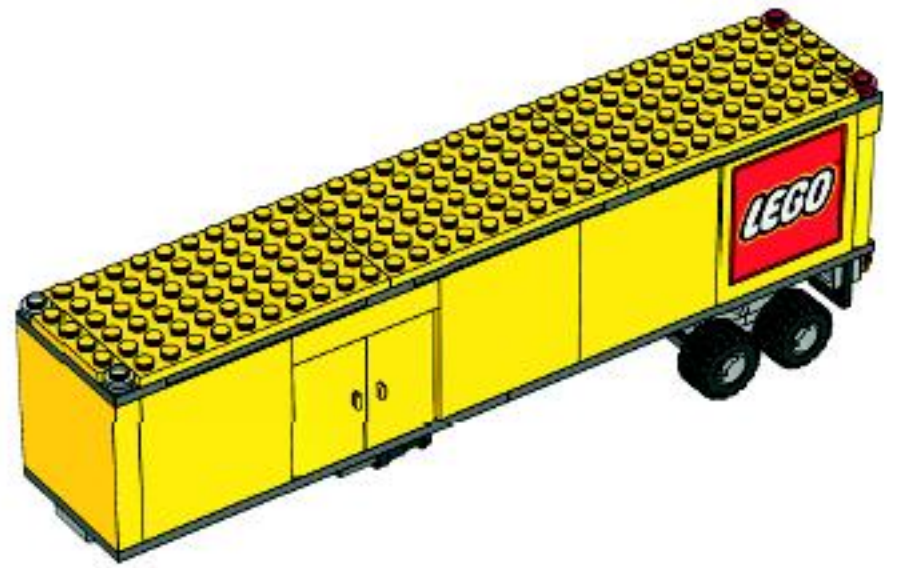

1

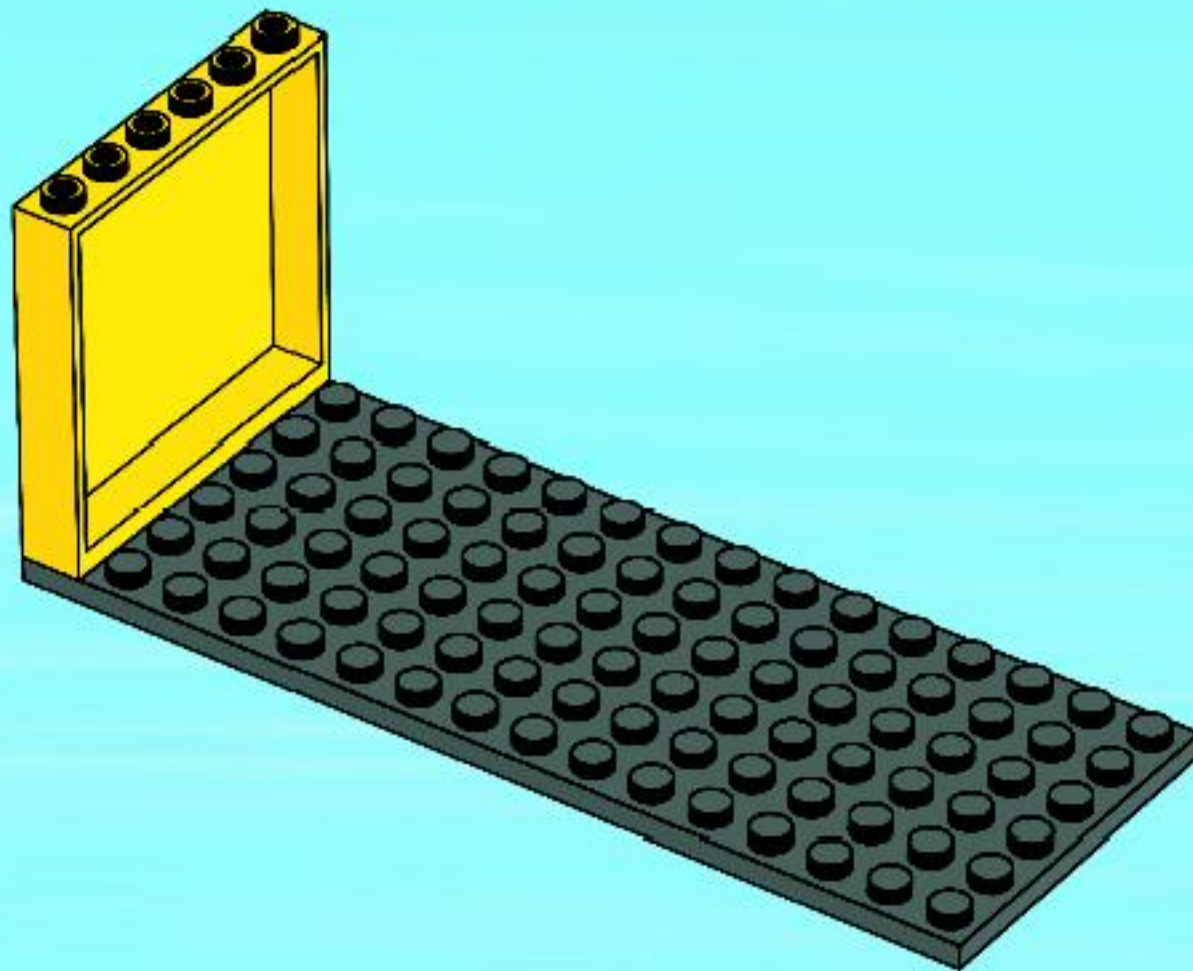

2

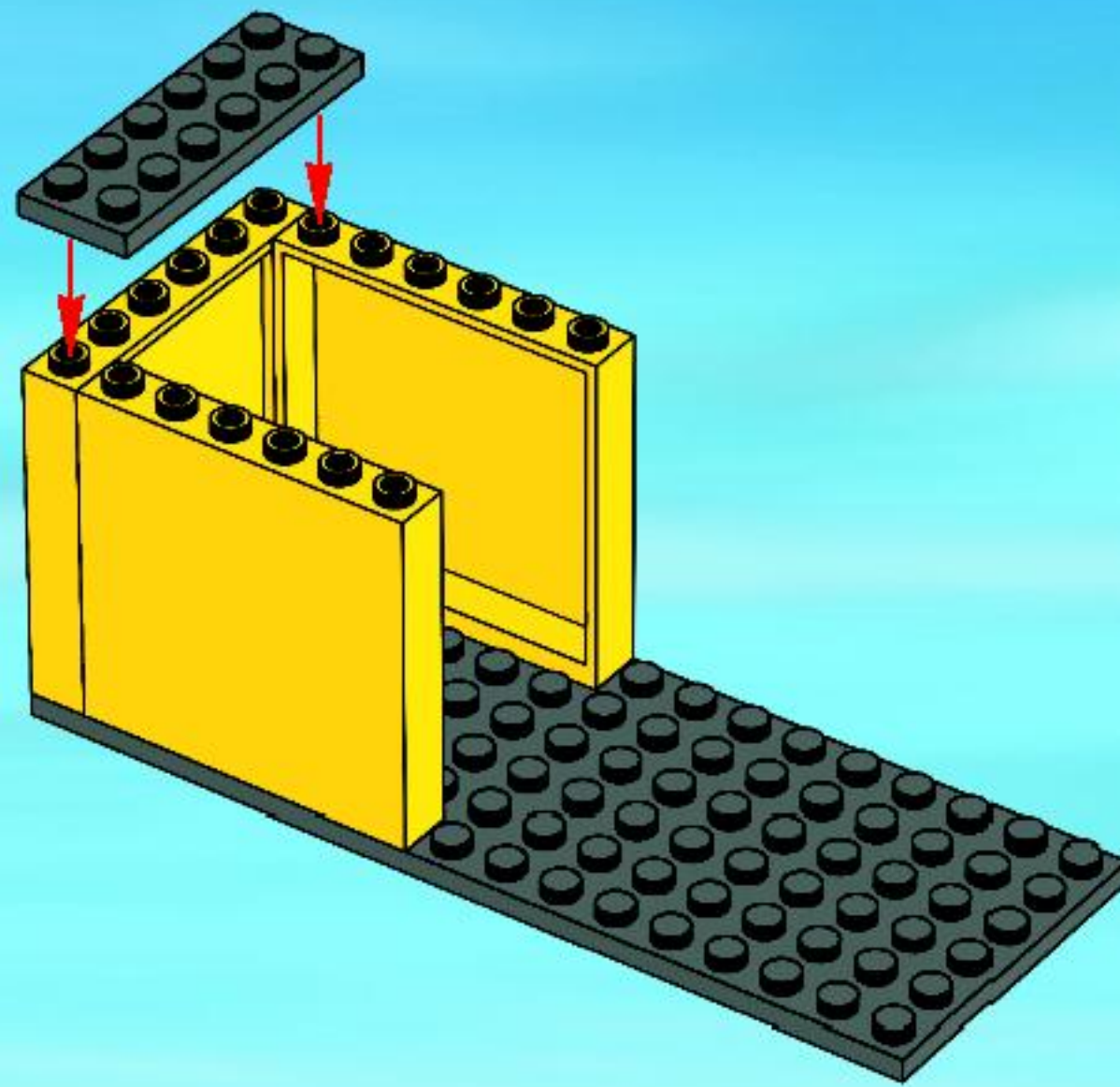

3

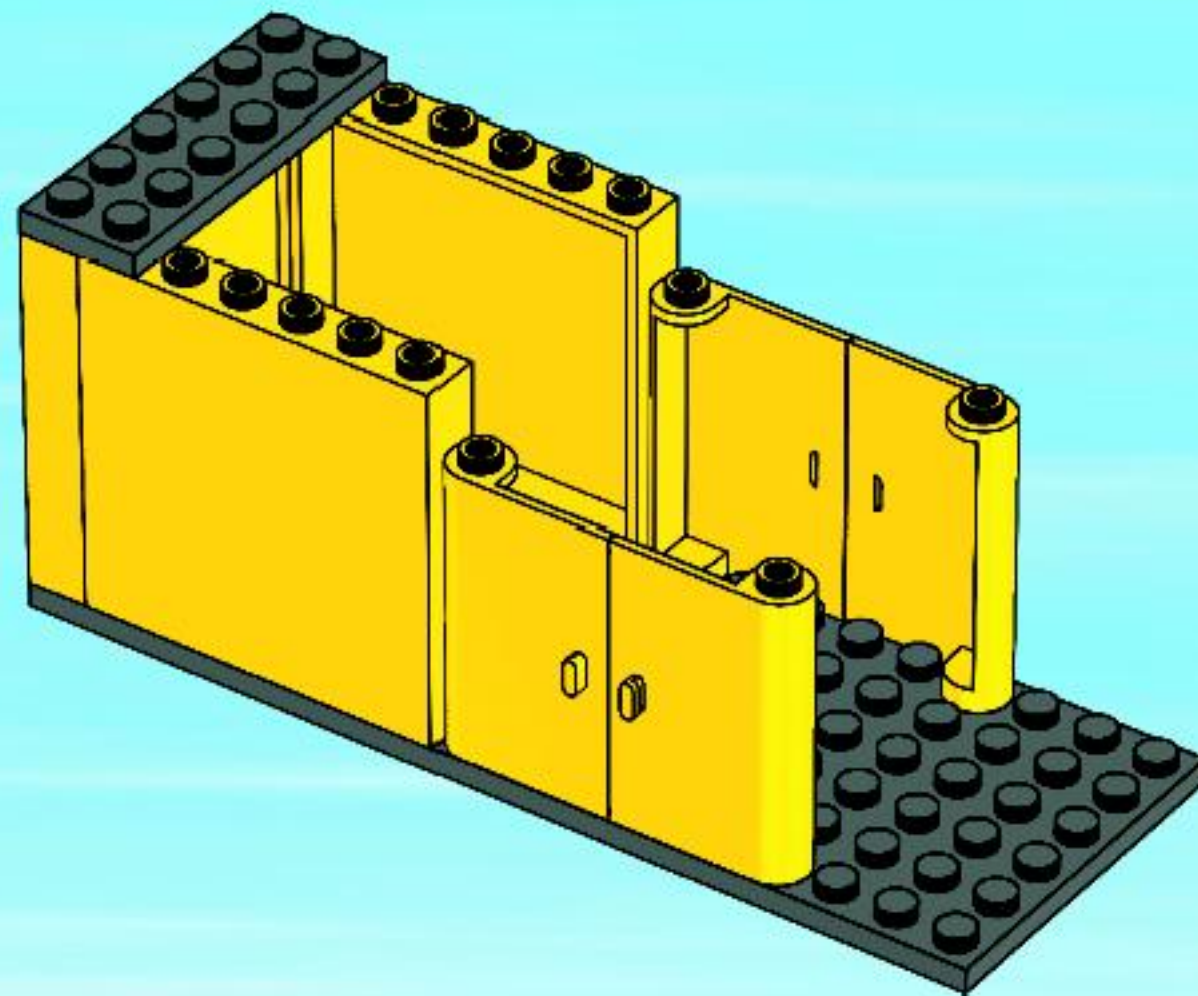

4

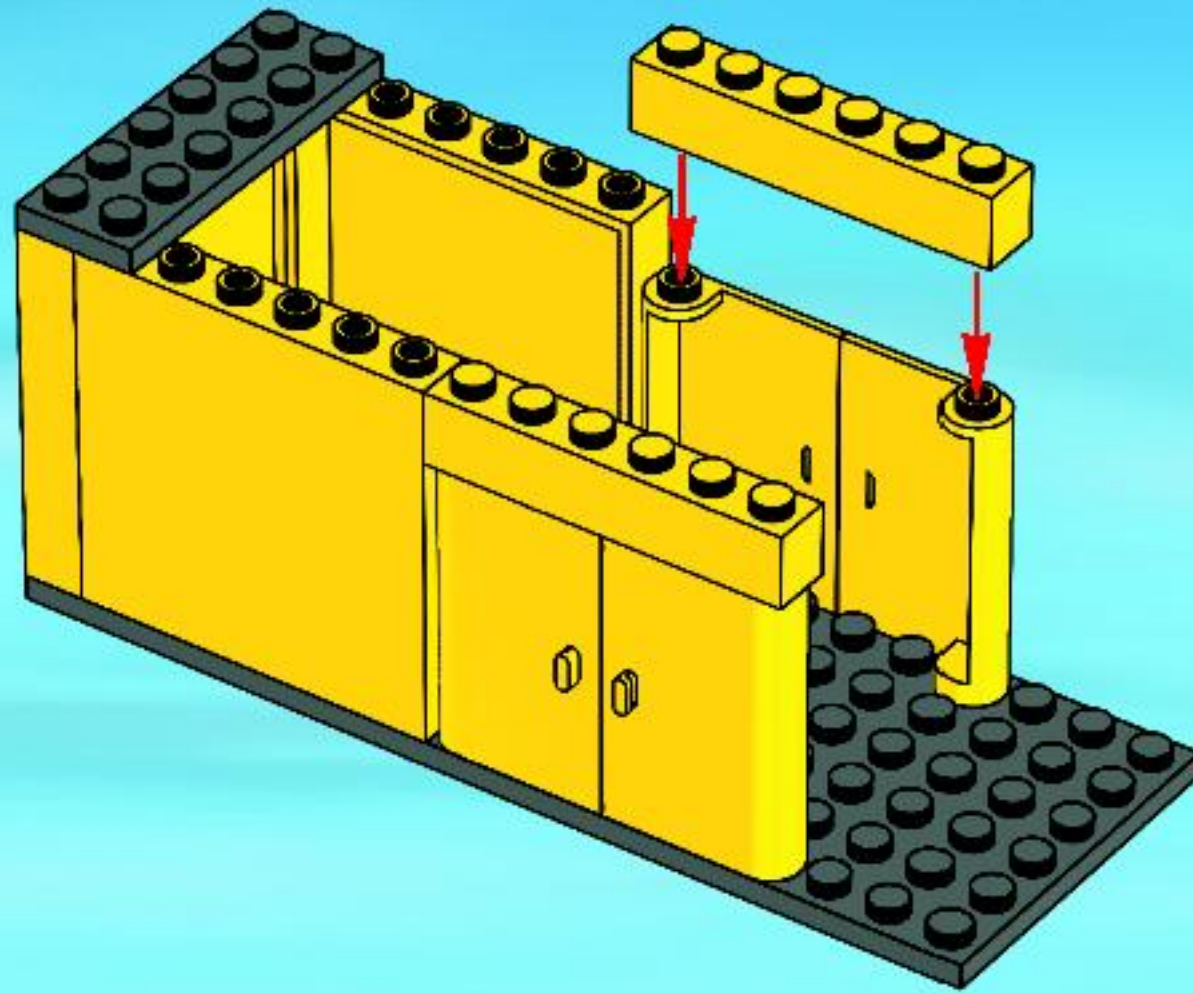

5

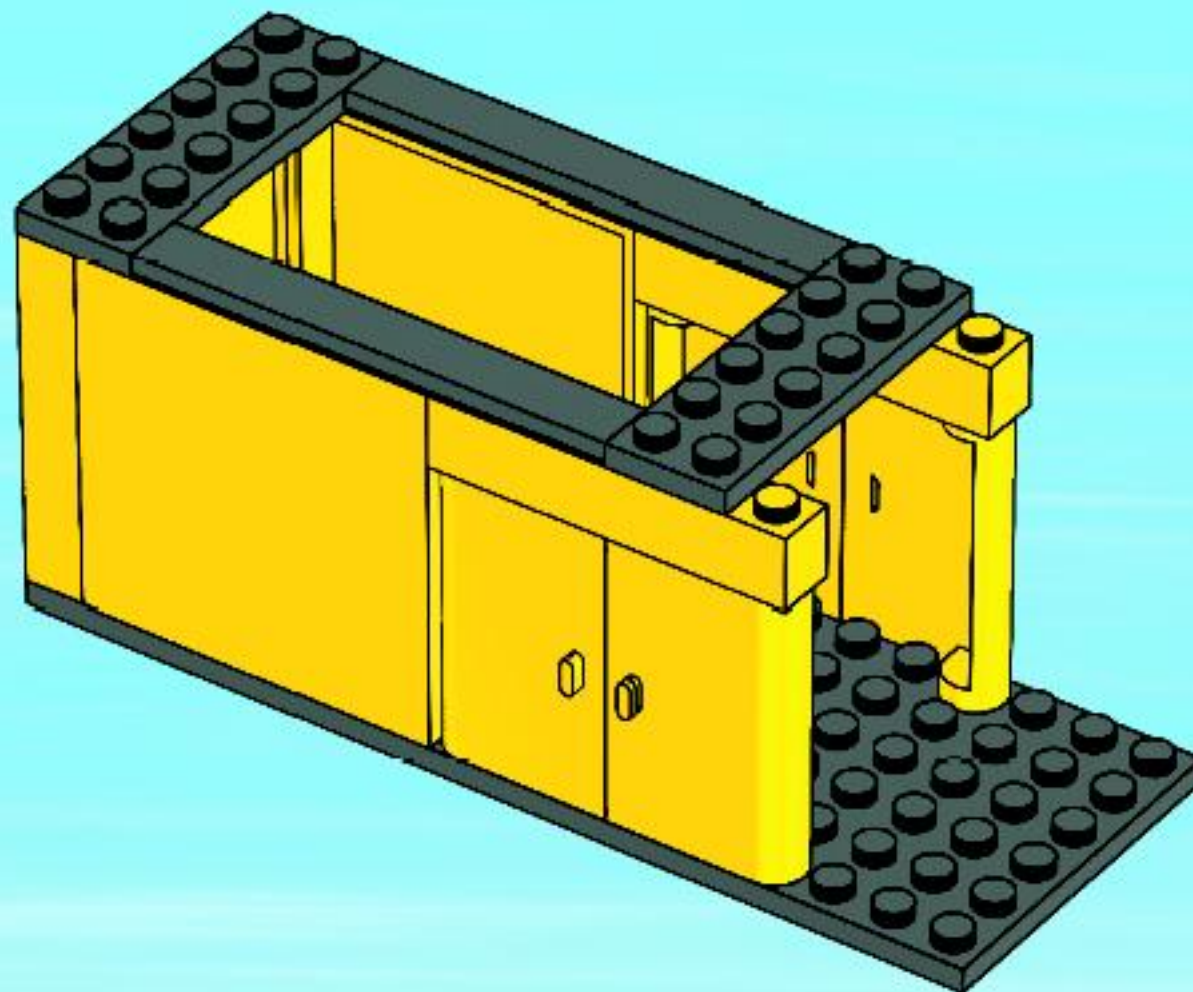

6

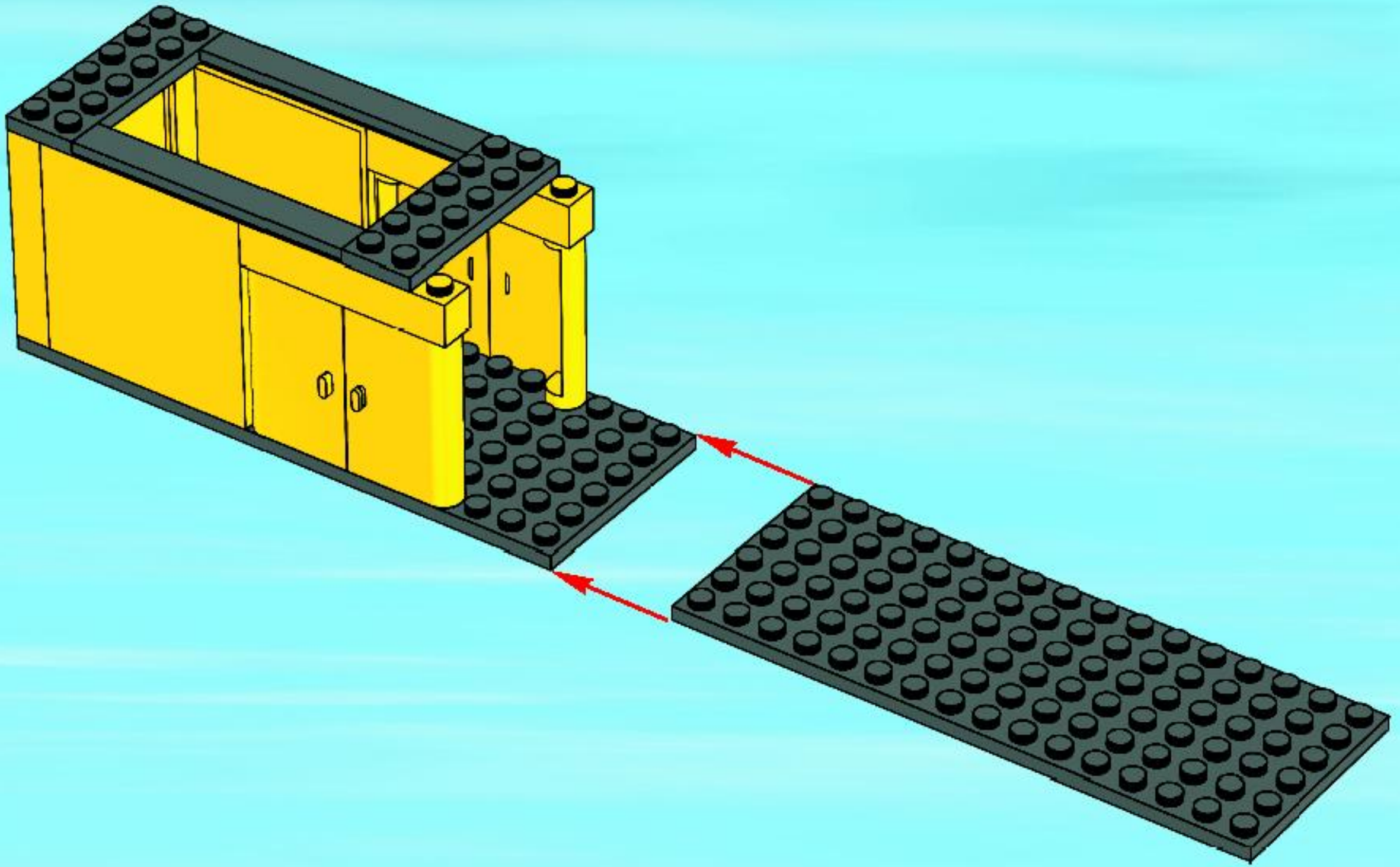

7

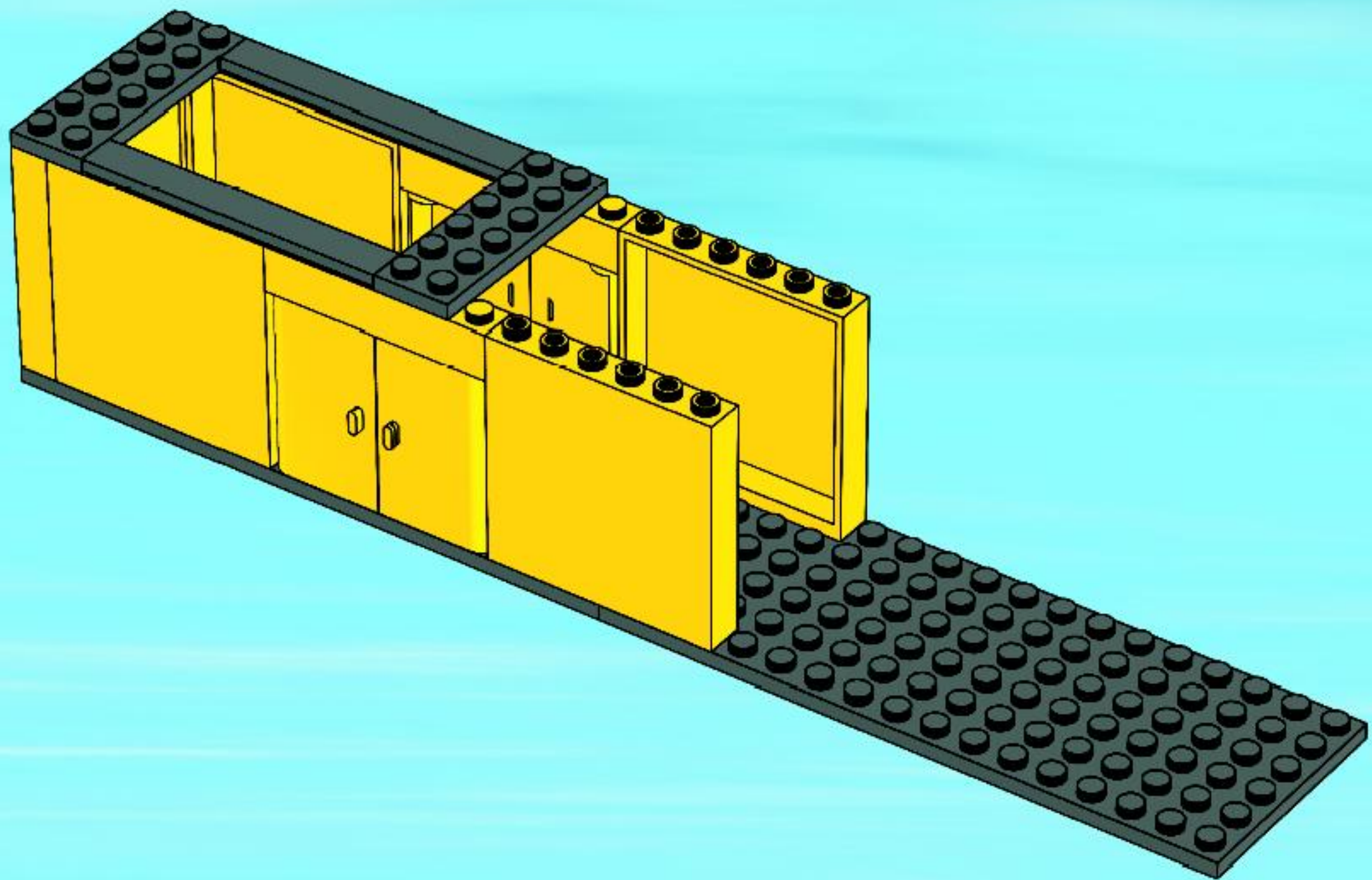

8

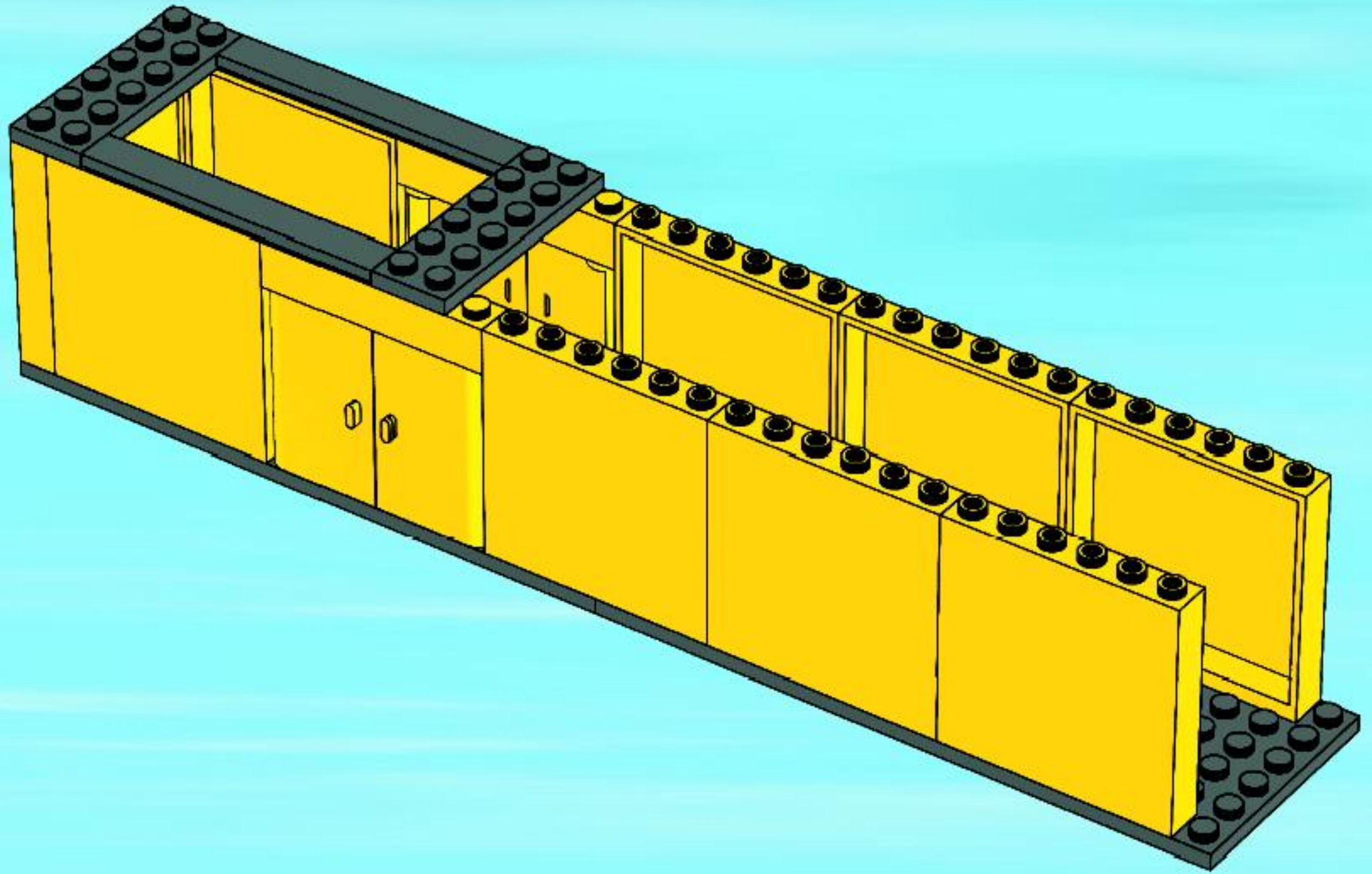

9

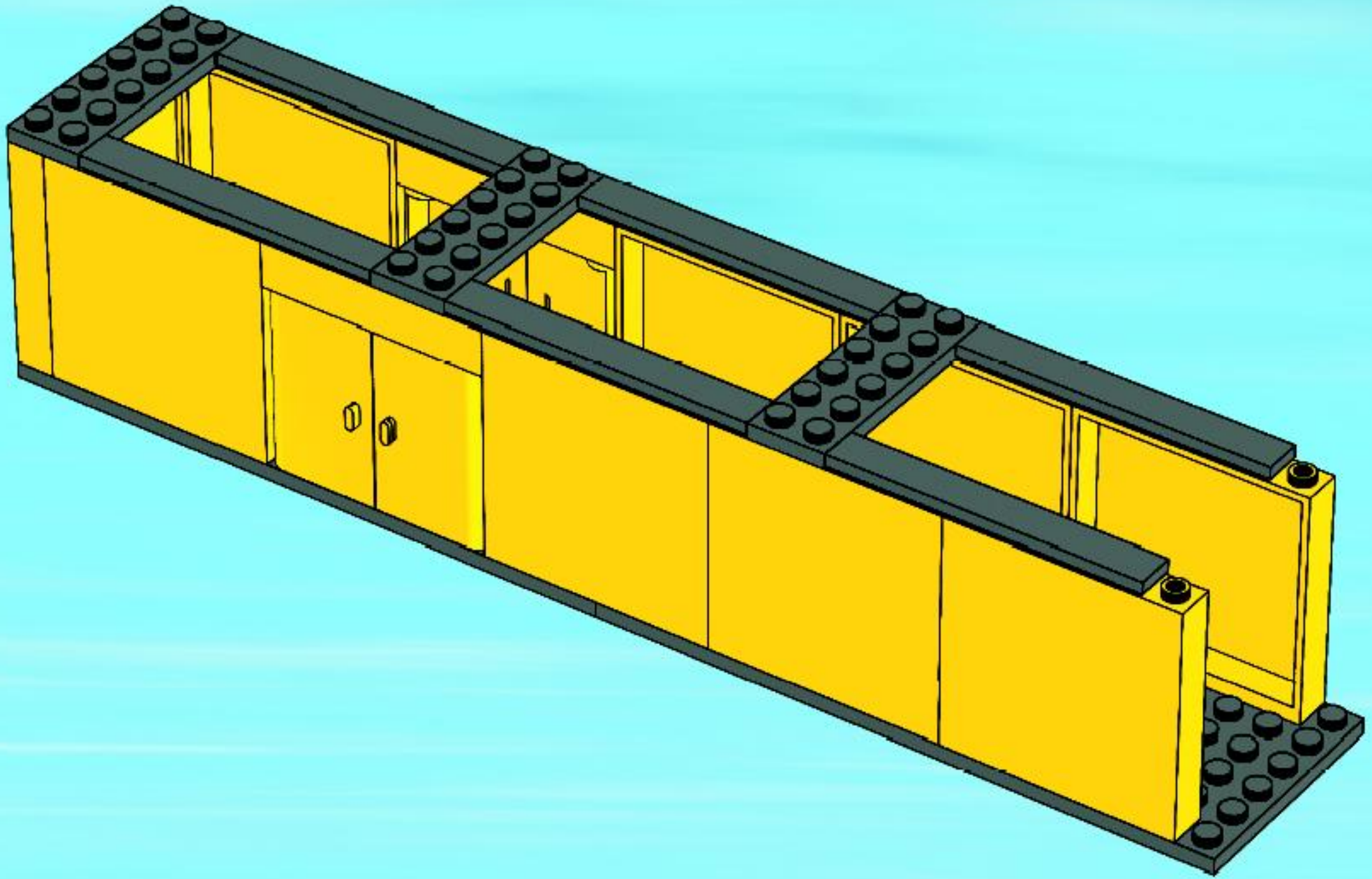

10

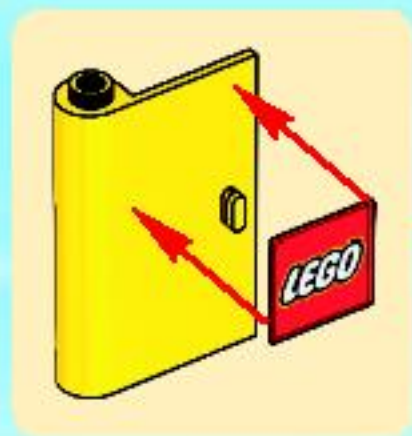
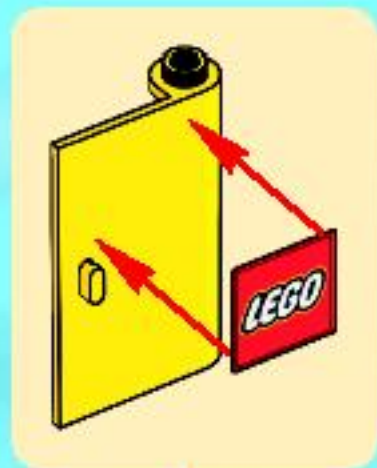
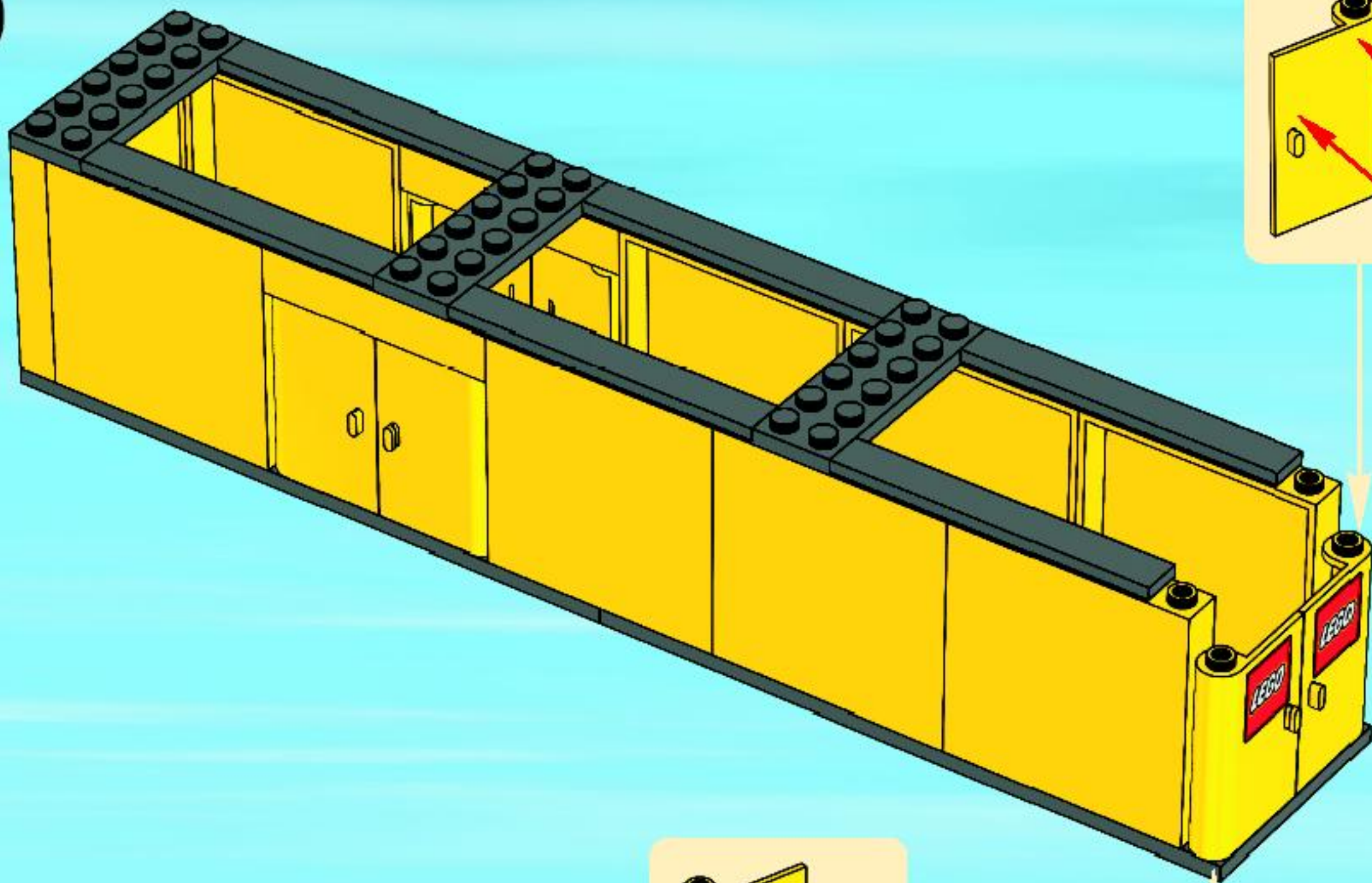

11

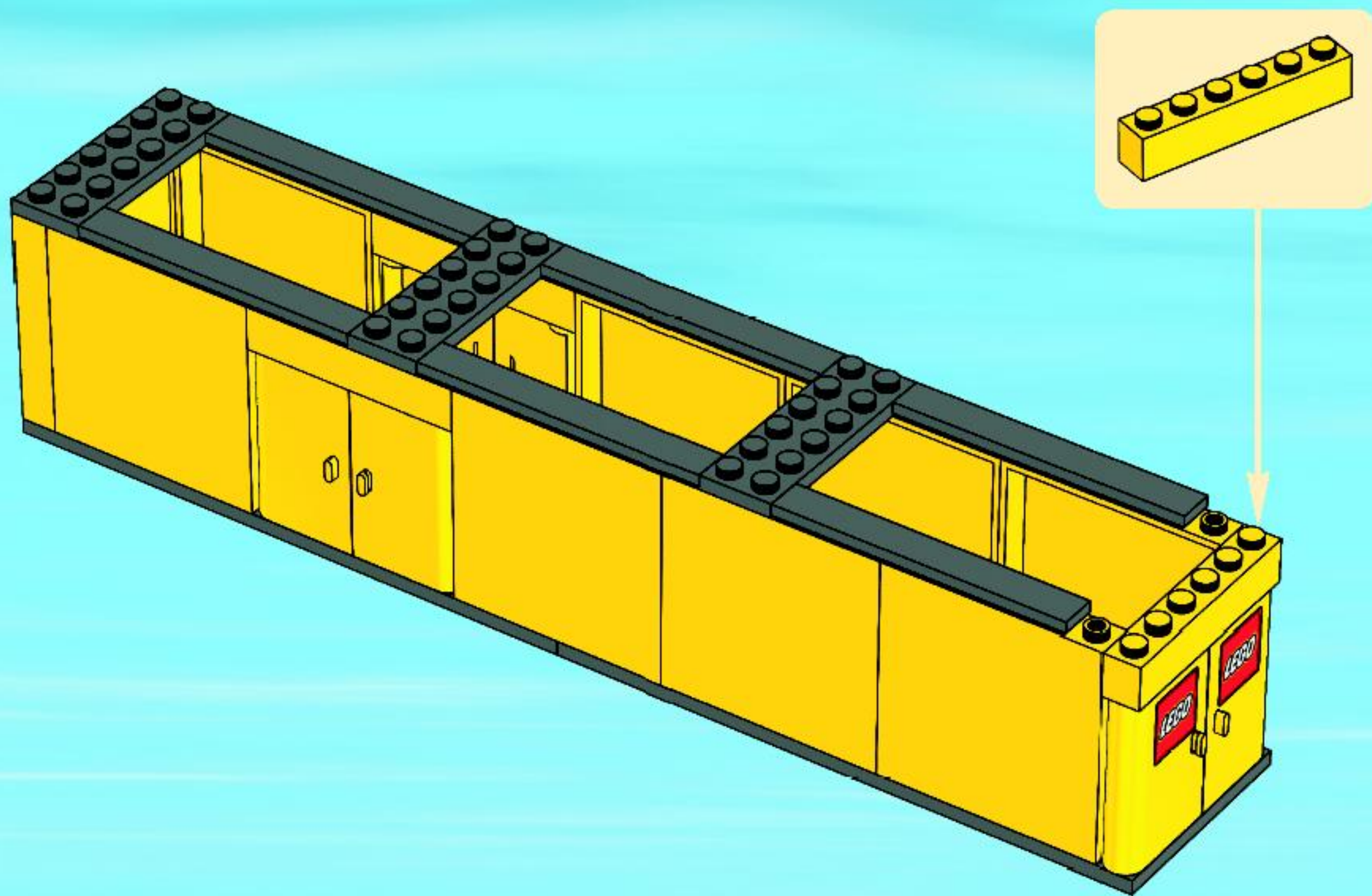

12

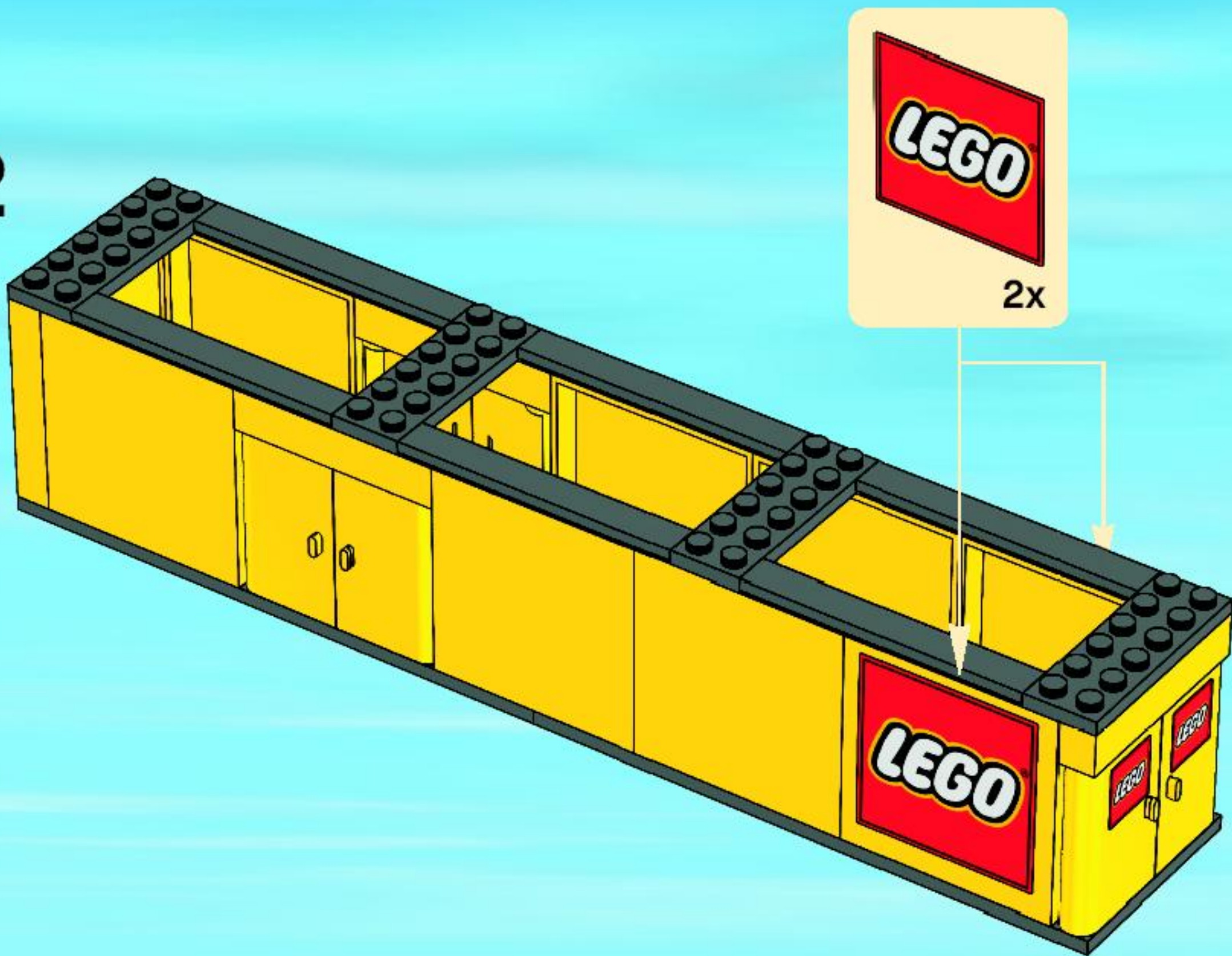

13

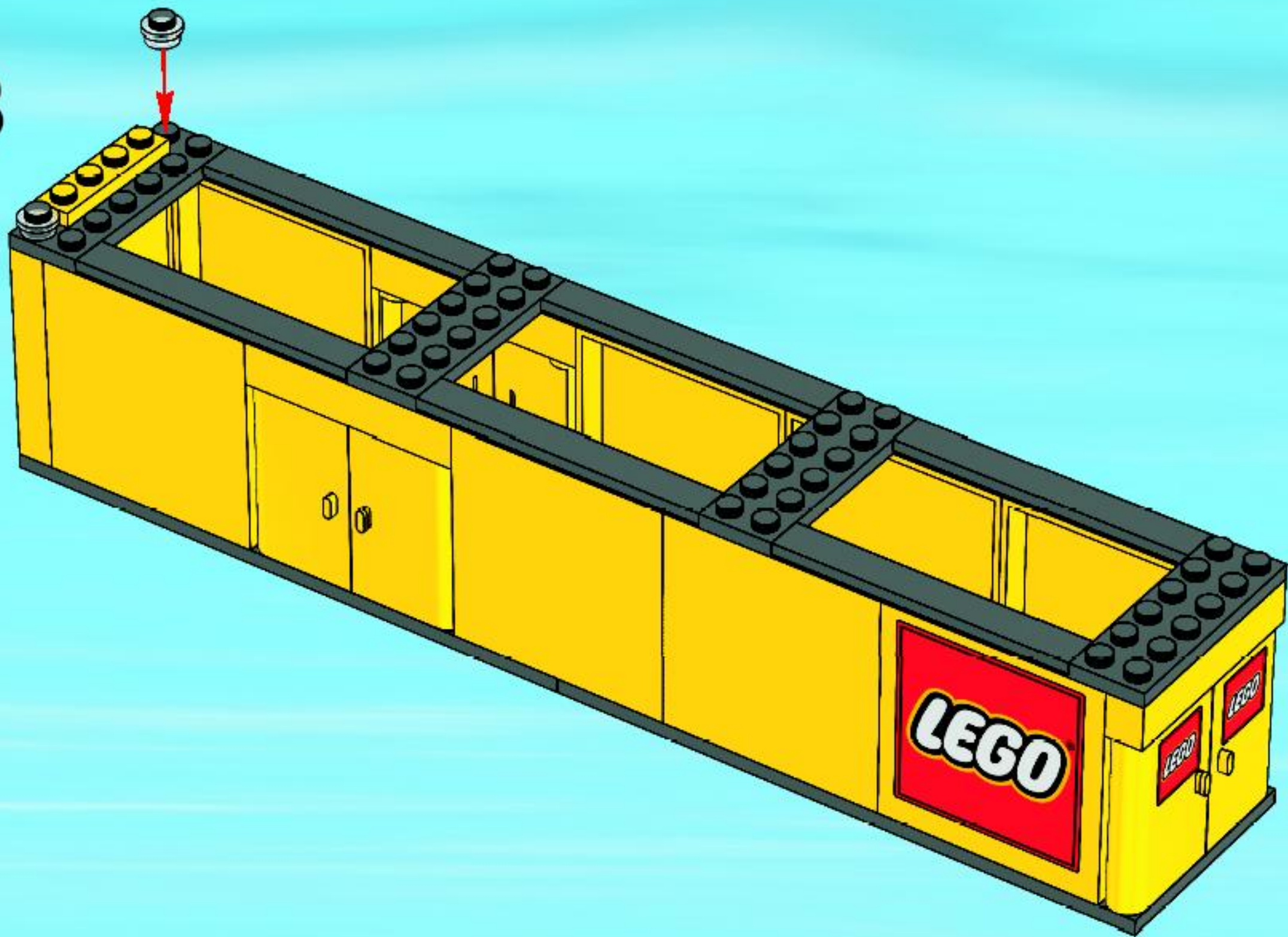

14

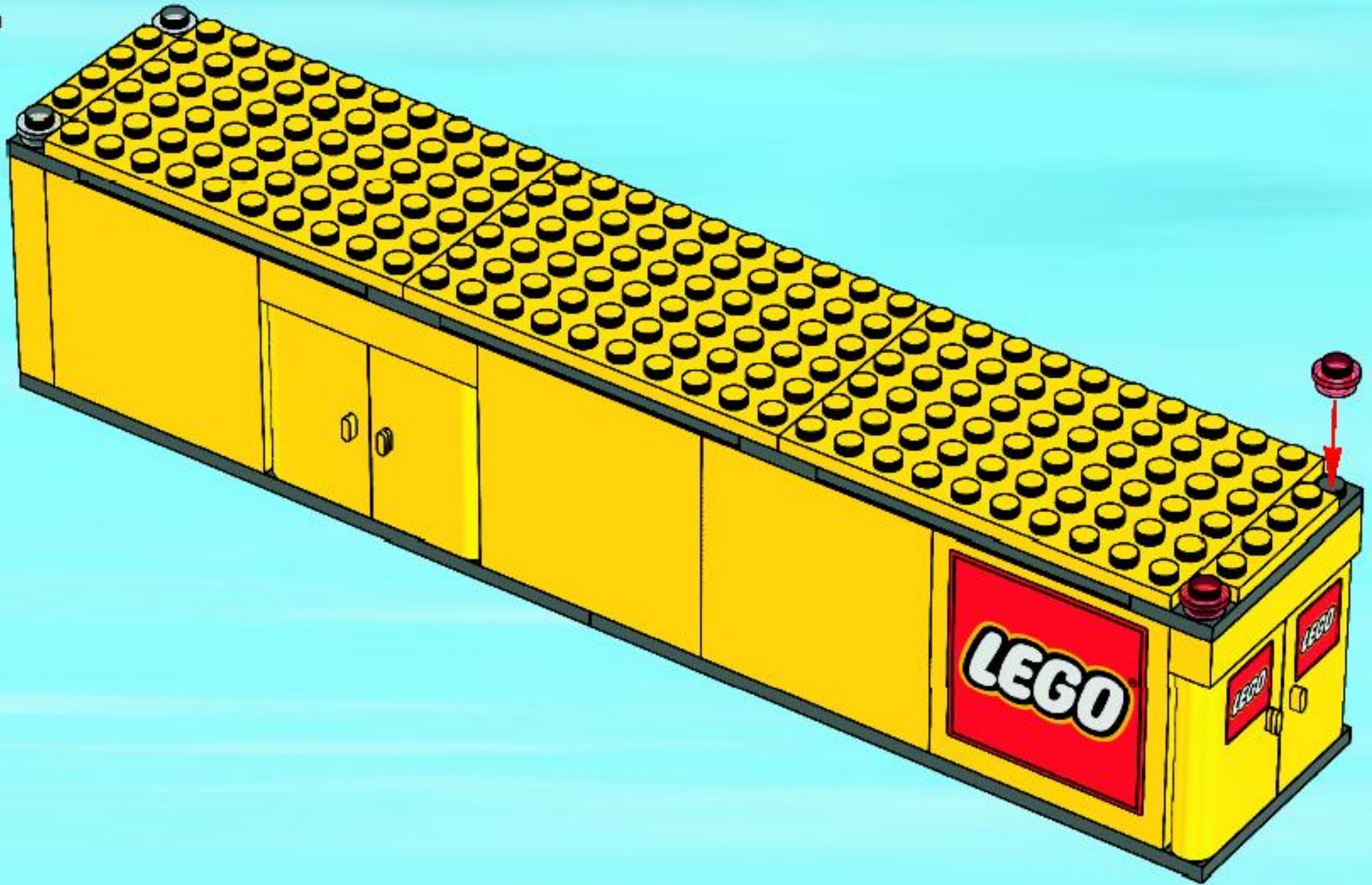

15

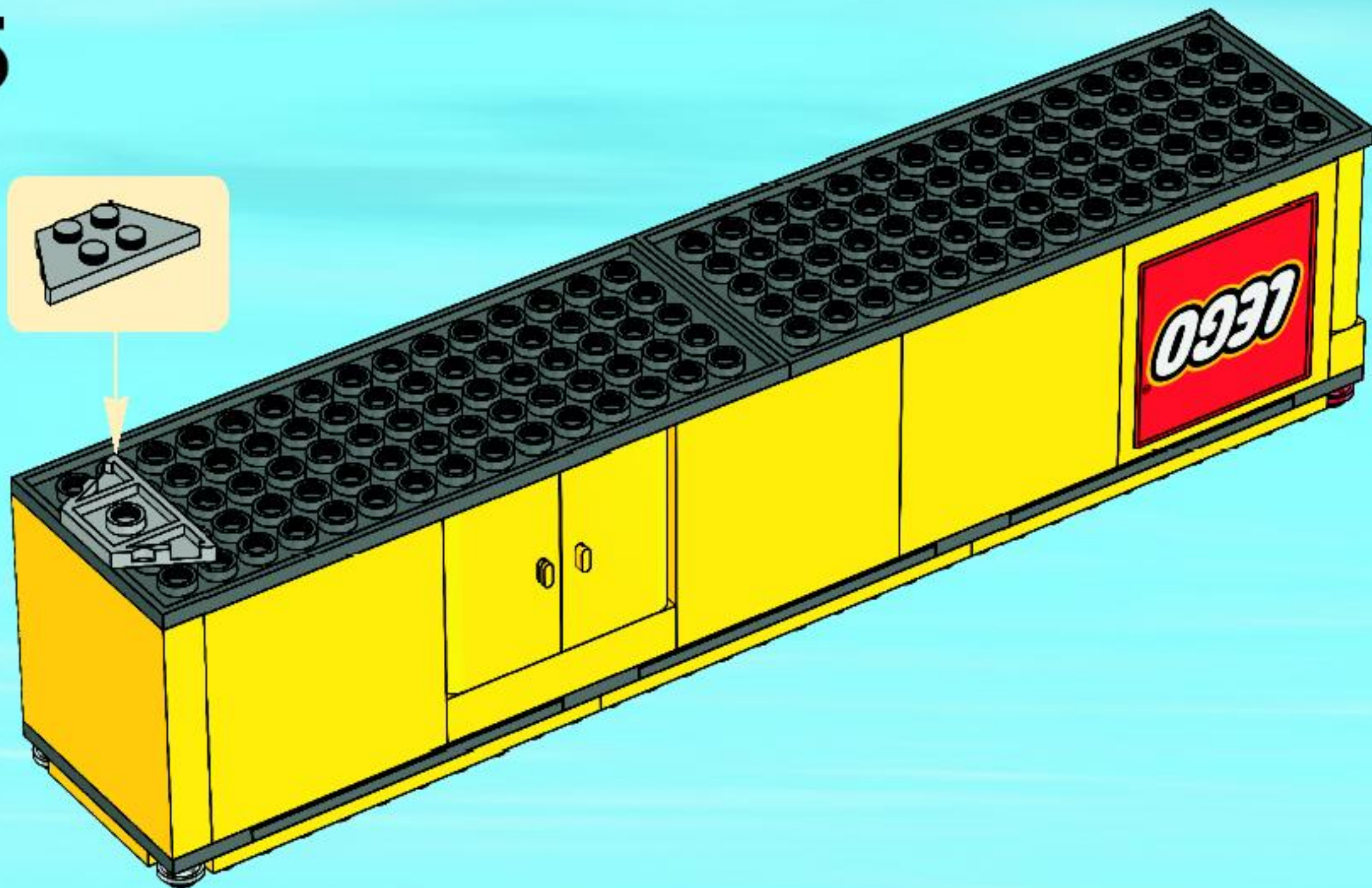

16

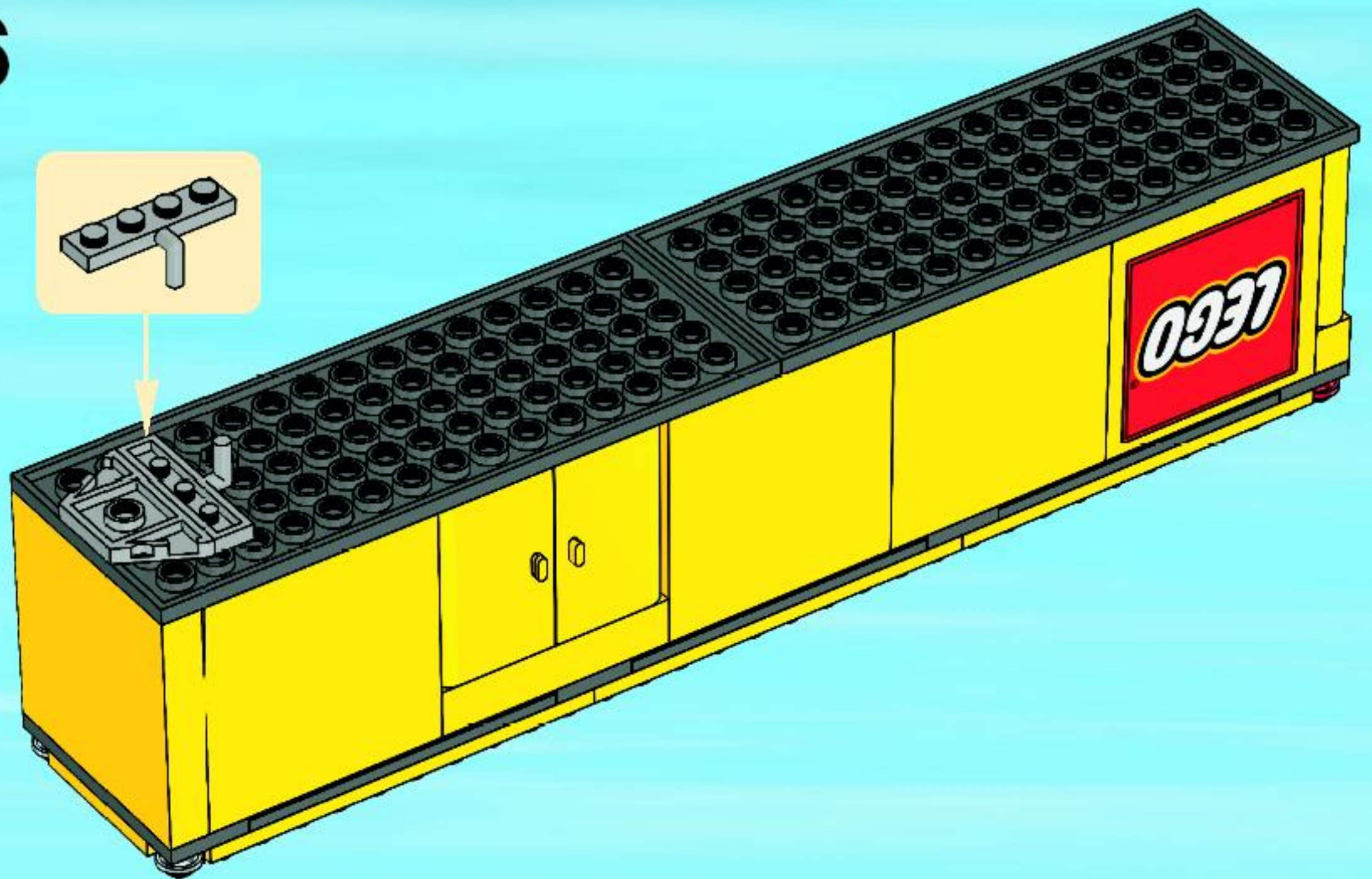

1

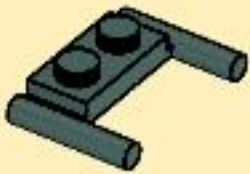

2

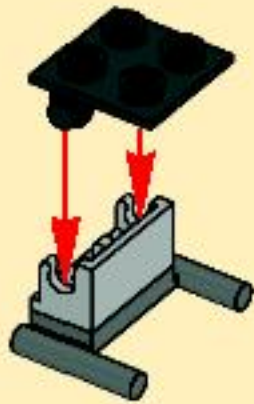

3

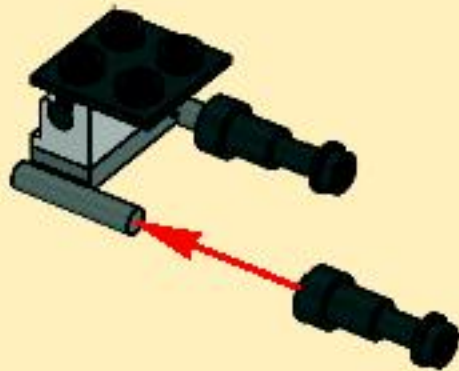

17

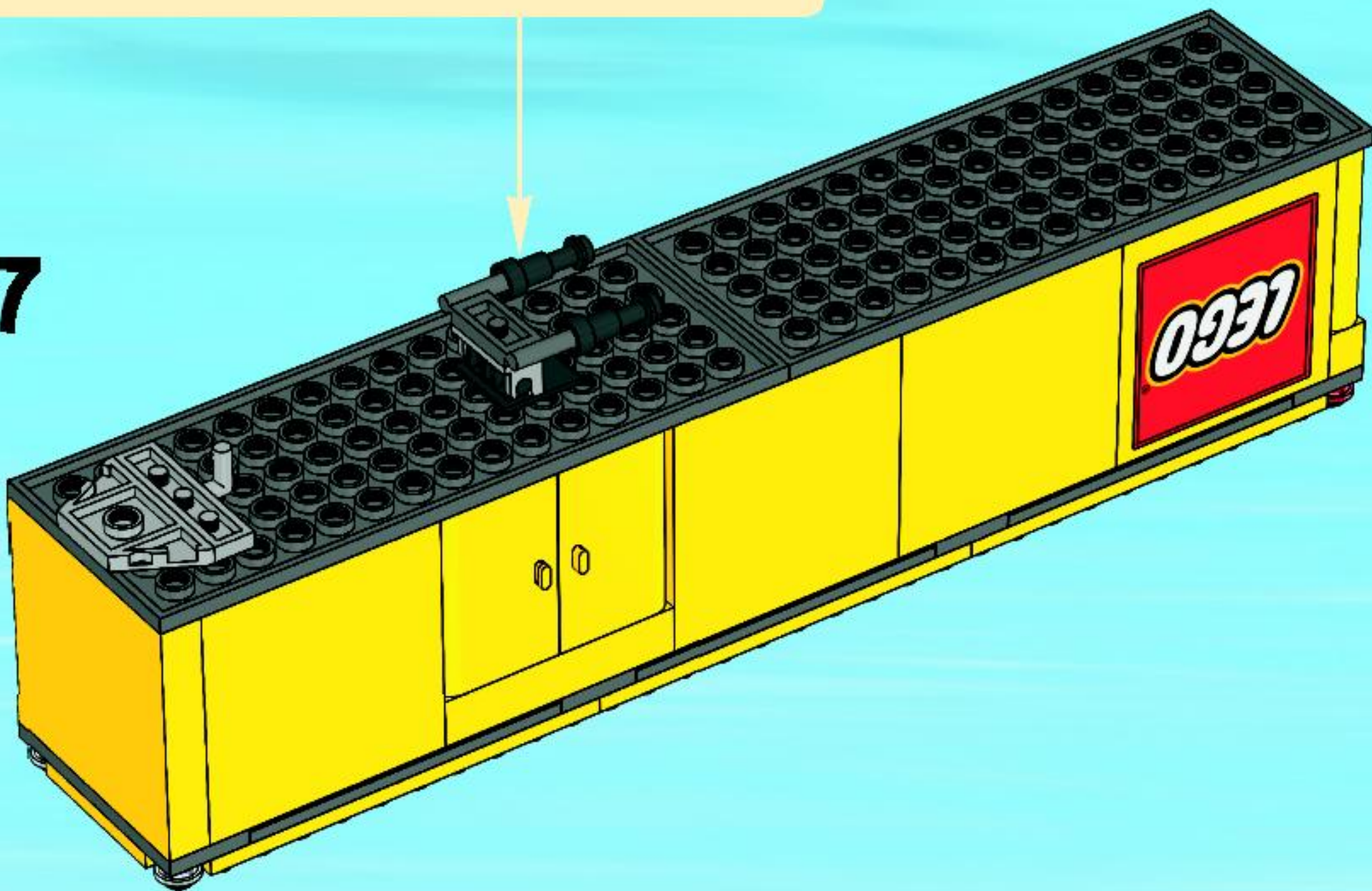

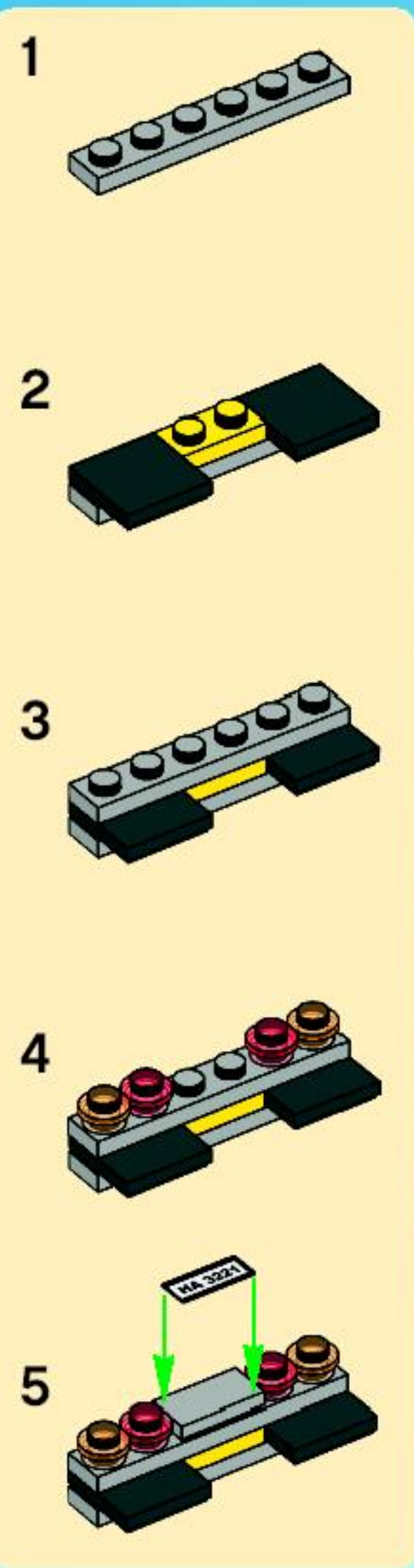
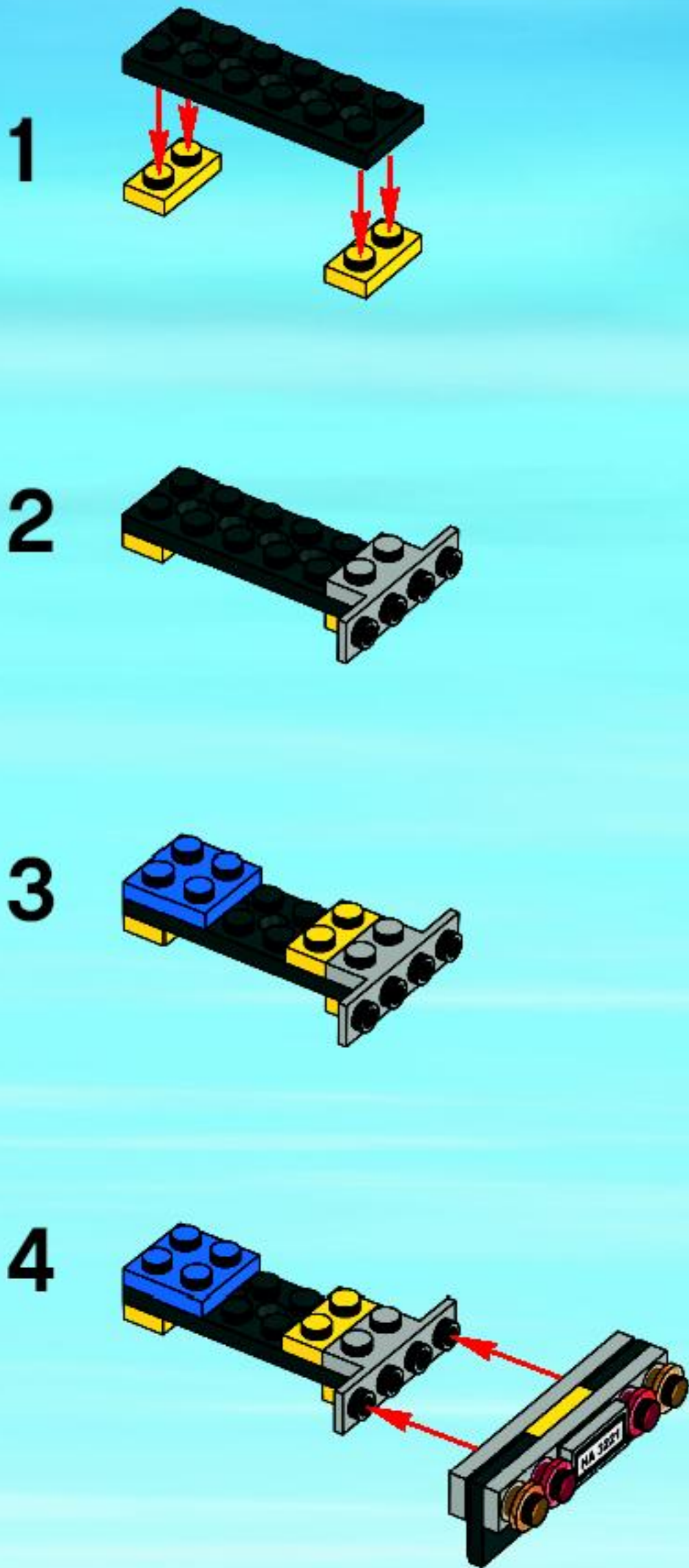

18





1



2



3



4

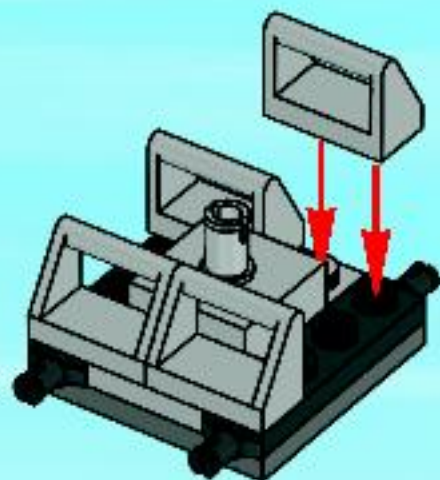

5

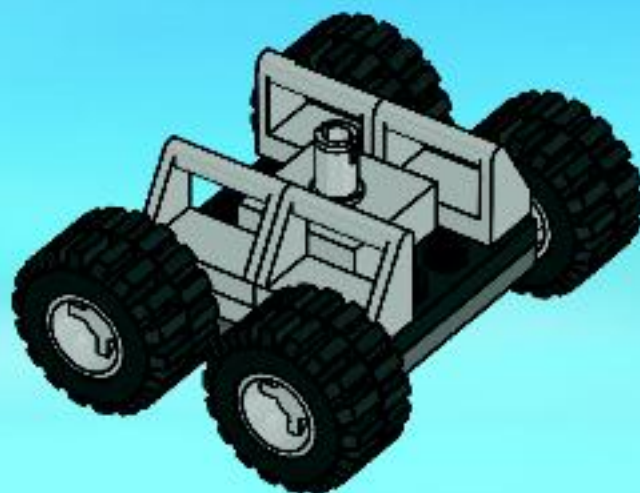

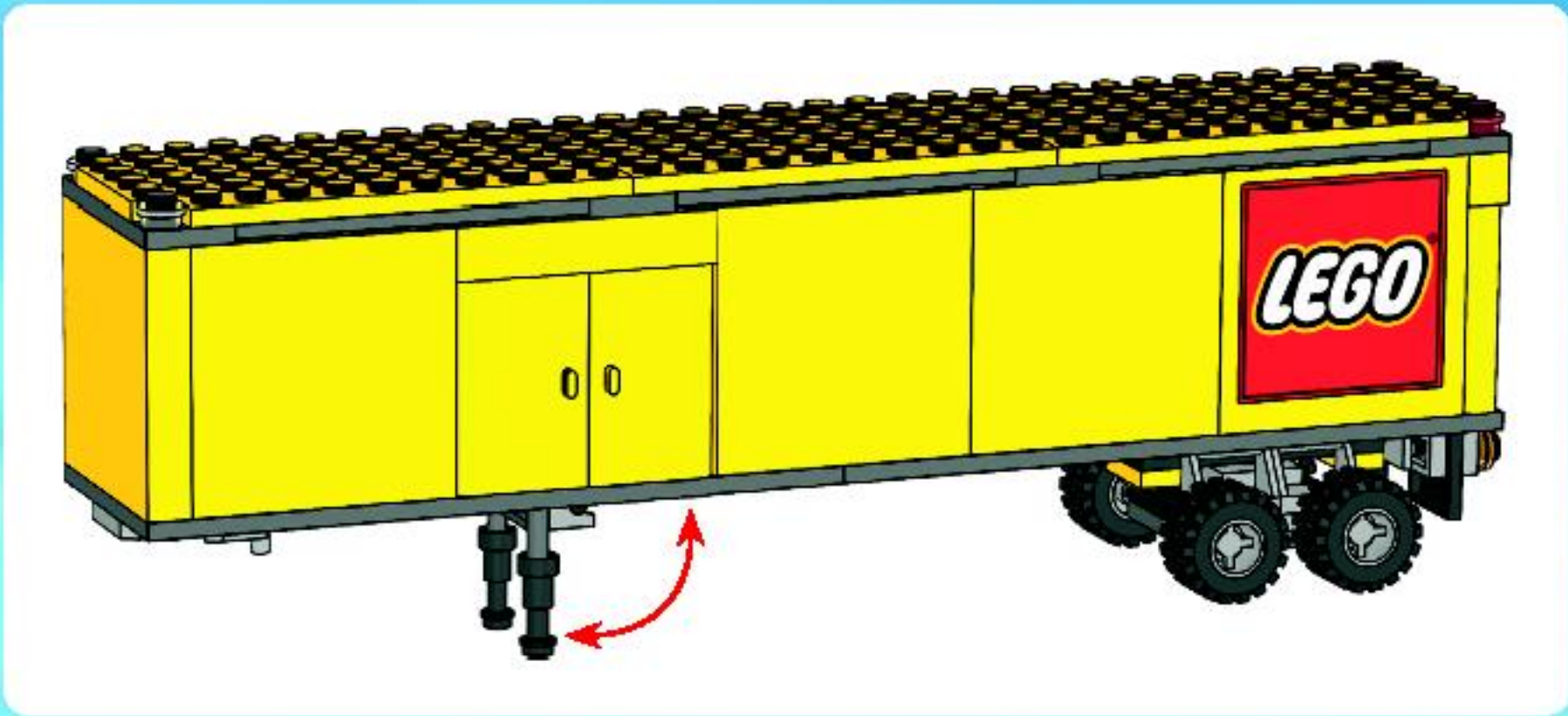

19



LEGO CITY



3177



3178



3179



3180



3181



3182

LEGO CITY



7241



7942



7239



7207



7208

FREE! GRATIS! GRATUIT!



club MAGAZINE™

www.LEGOclub.com



00800 5346 5555*

1-866-534-6258 • 1-877-518-5346
US & Canada only Canada seulement

VISIT THE WORLD'S
BIGGEST LEGO® SHOP!

www.LEGOshop.com

* Free phone. Mobile charges may apply. * Numéro sans frais. Des frais peuvent s'appliquer avec les téléphones cellulaires. * Gebührenfrei, Kosten für Anrufe aus Mobilfunknetzen können anfallen.
* Gratis telefonnummer van vaste lijn. * Doer et gratis nummer, air du ringer fra Posttelefon. * Det är gratis, air du ringer från en Post telefon.



Customer Service
 Kundenservice
 Service Consommateurs
 Servicio Al Consumidor

www.lego.com/service or dial



: 00800 5346 5555

: 1-800-422-5346

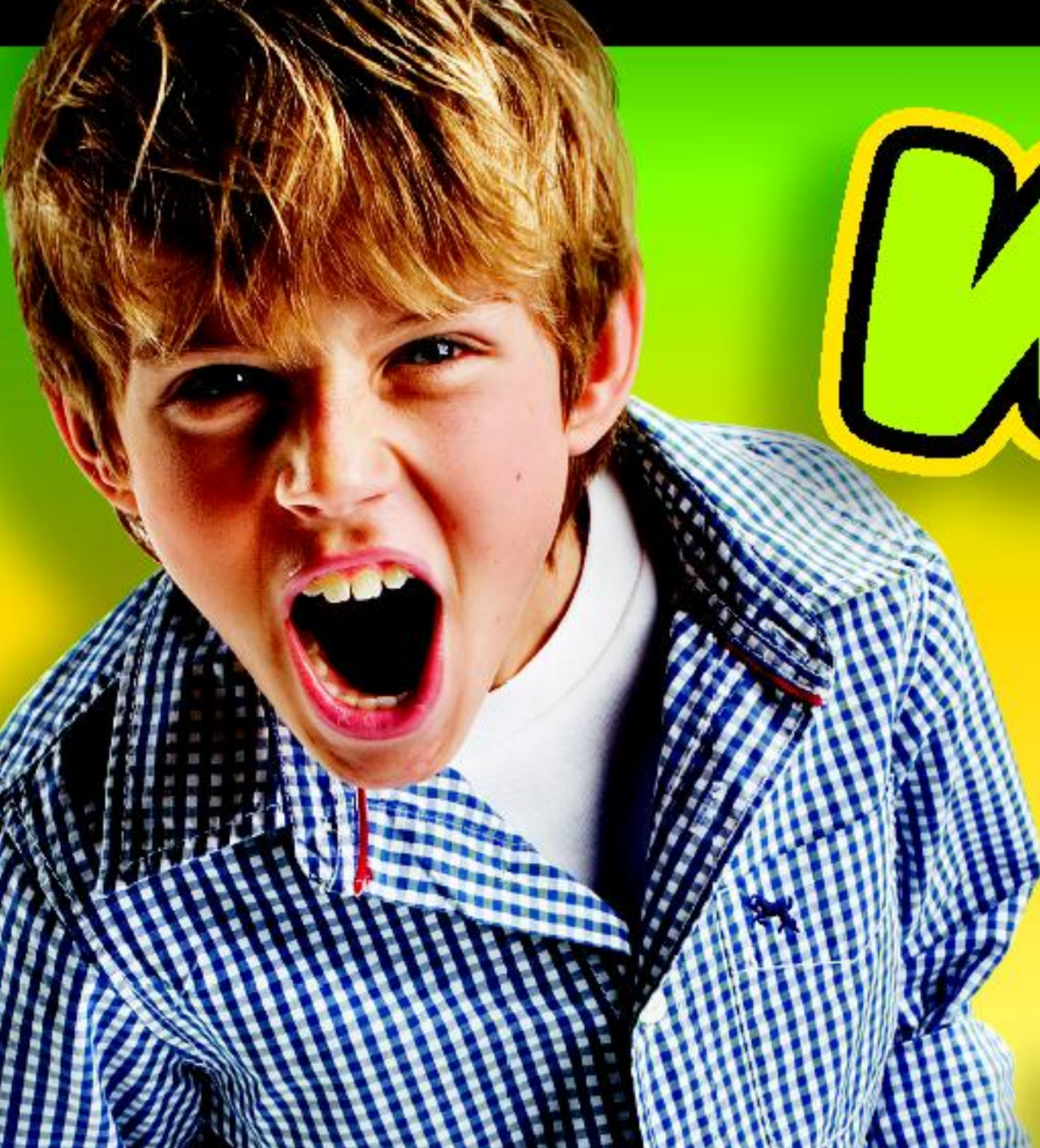

WIN!

Go to www.nielsen.com/LEGO to fill out a survey for a chance to win a cool LEGO® Product.

No purchase necessary.

Open to all residents where not prohibited.



www.nielsen.com/LEGO

GEWINNE! WIN!

Nimm an der Umfrage auf www.nielsen.com/LEGO teil und hab die Chance ein cooles LEGO® Produkt zu gewinnen!

Die Teilnahme am Gewinnspiel führt zu keinerlei Kaufverpflichtungen. Teilnahme in allen nicht ausgeschlossenen Ländern möglich.

Ga naar www.nielsen.com/LEGO, vul een enquêteformulier in en maak kans op een cool LEGO® product.

Geen aankoopverplichting. Iedereen mag deelnemen, uitzonderd ingezetenden van landen waar een enquêteverbod geldt.

GAGNE! 当てよう!

Visite www.nielsen.com/LEGO pour répondre à un questionnaire et avoir une chance de gagner un produit LEGO® très cool!

Aucune obligation d'achat. Ouvert à tous les résidents des pays autorisés.

www.nielsen.com/LEGOにアクセスして、アンケートにご記入ください。当選者にはレゴ製品を差し上げます。

お買い上げの義務はありません。

禁止されていない限り、すべての年齢にご利用いただけます。