



HEROFACTORY



2283

WITCH DOCTOR

1

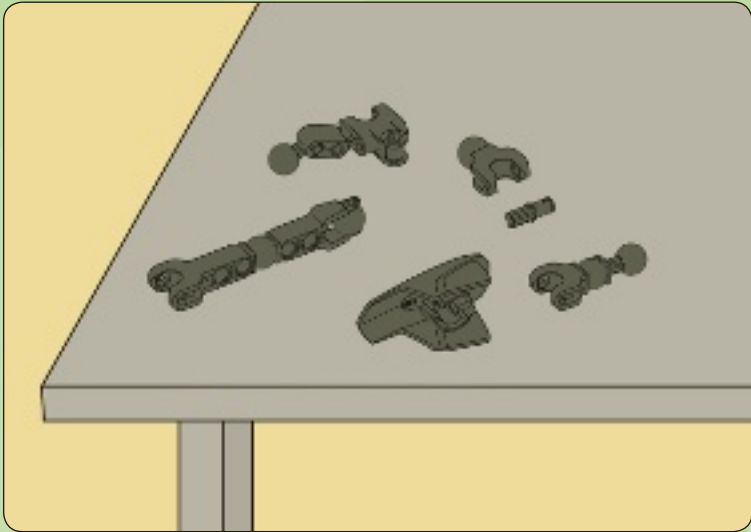
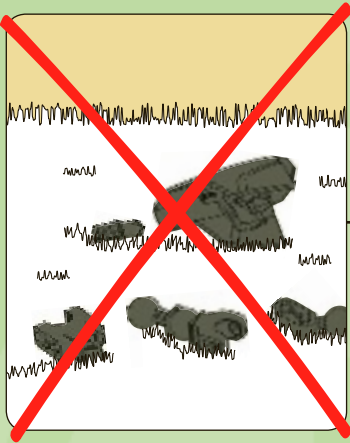

2

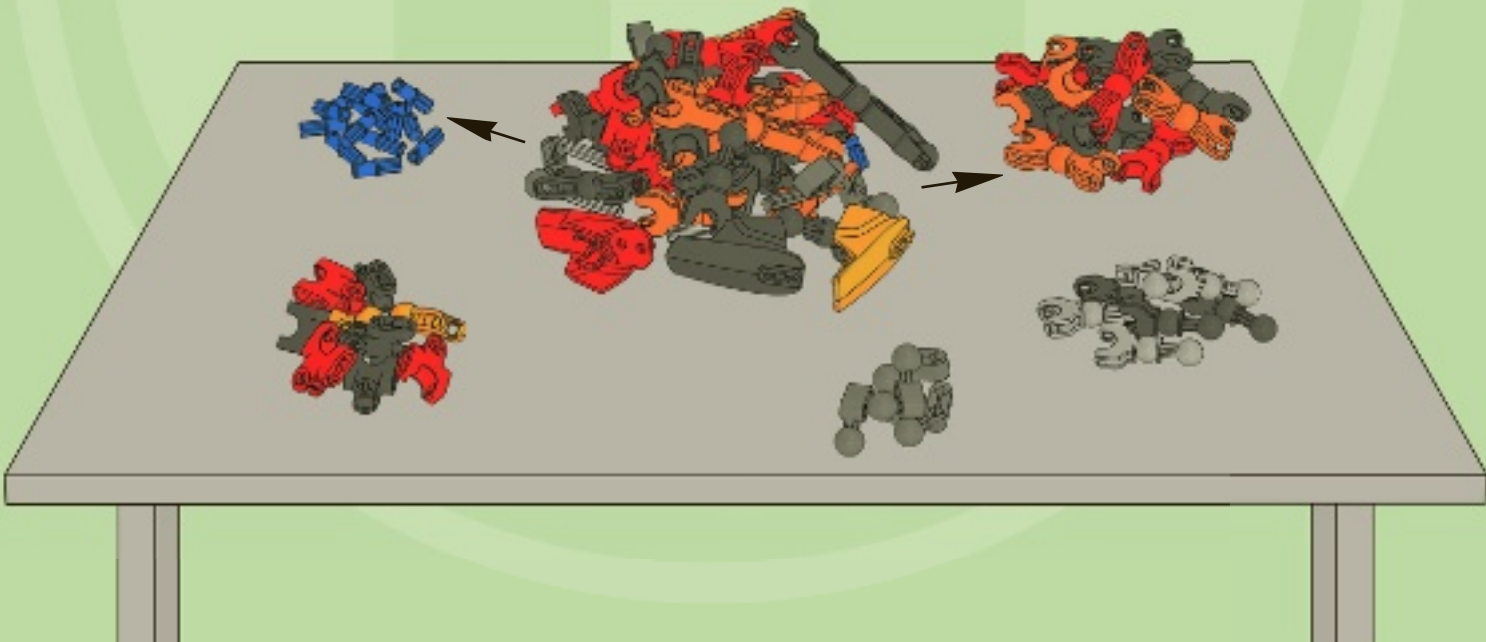



1

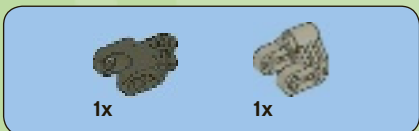
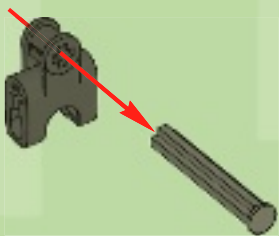

2

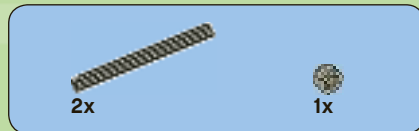
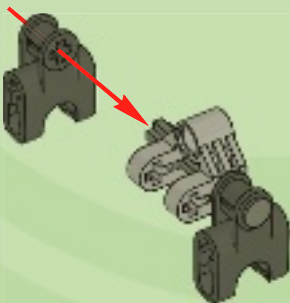

3

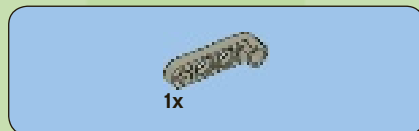
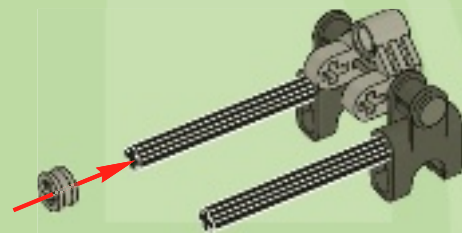

4

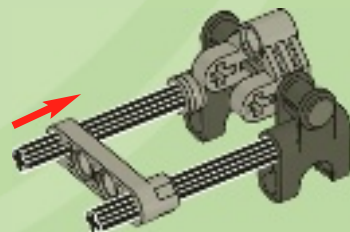

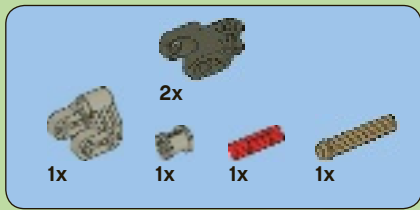

5

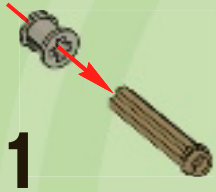

2



3

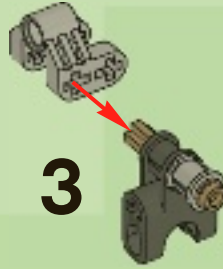

4

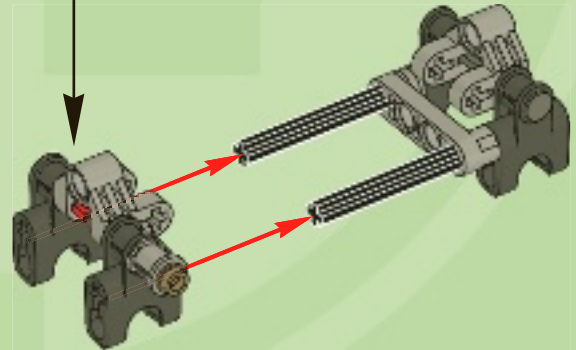



2x



2x

6

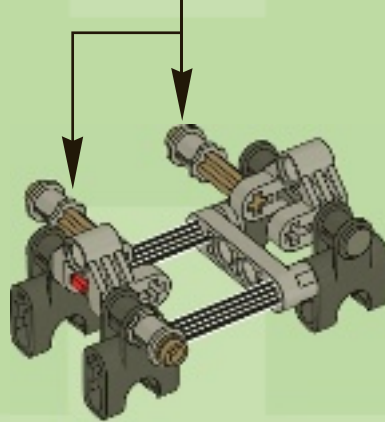
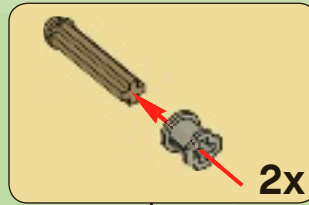

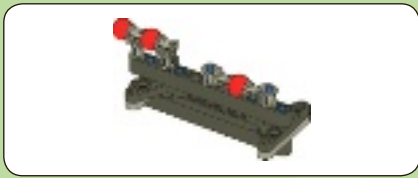

1

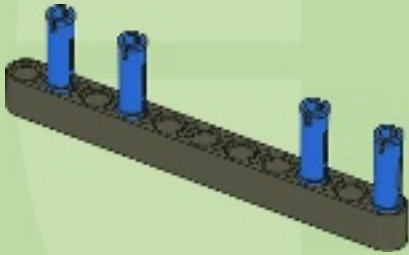

2

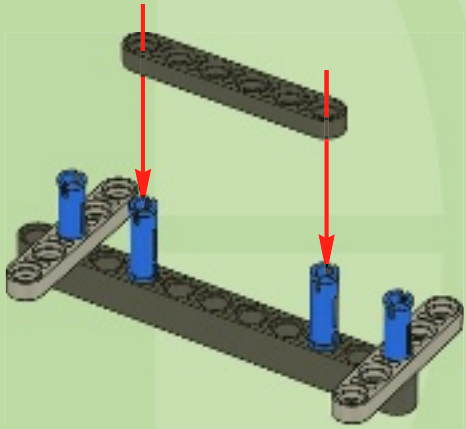

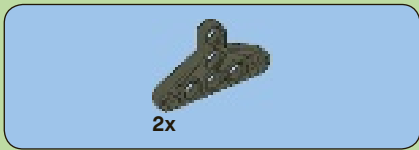

3

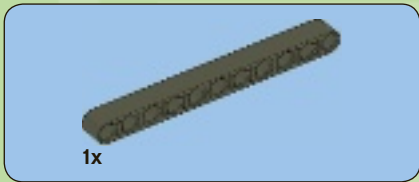
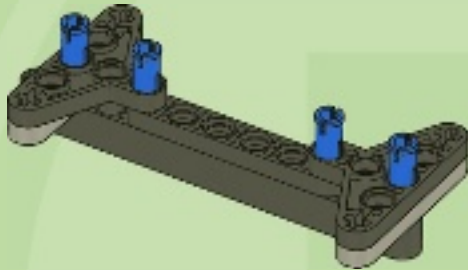

4

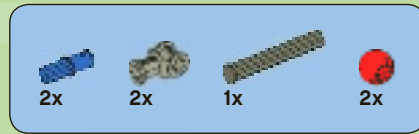
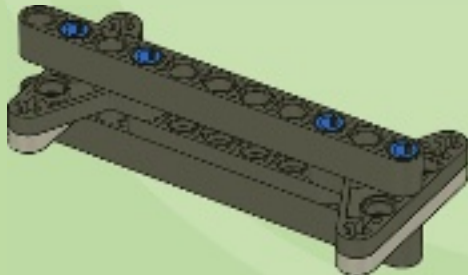

5

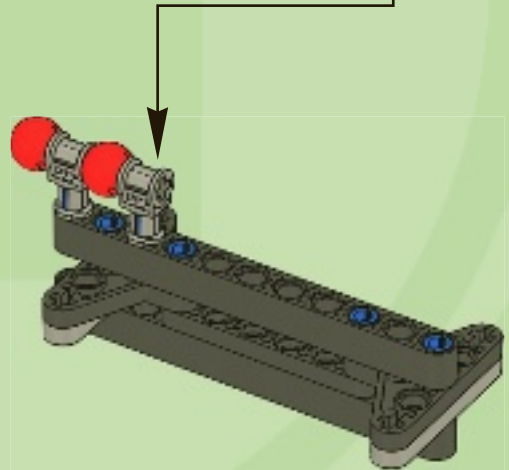
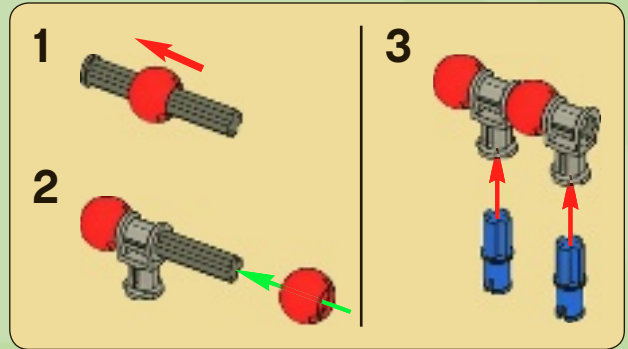

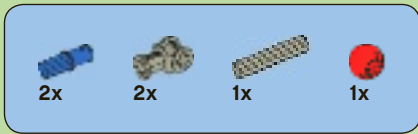

6

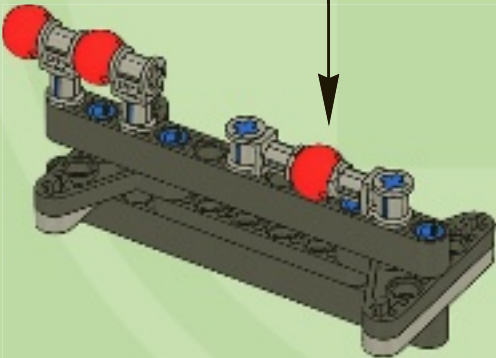
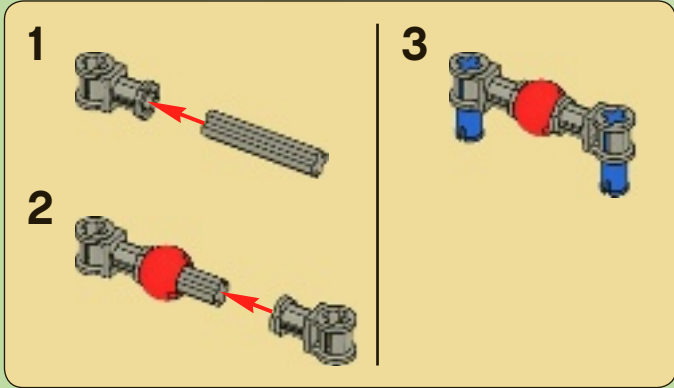

7

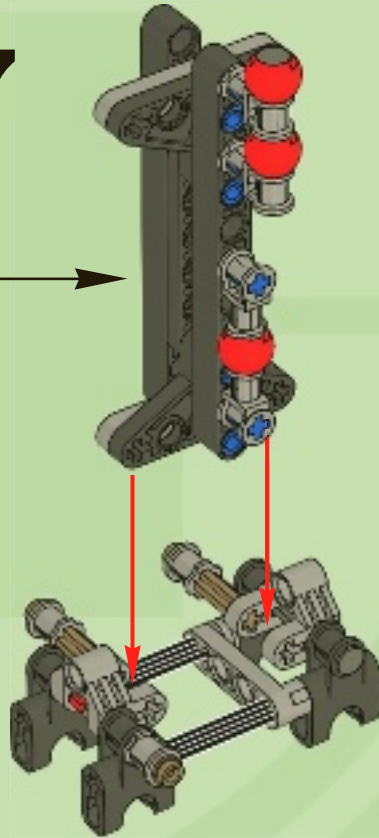

8

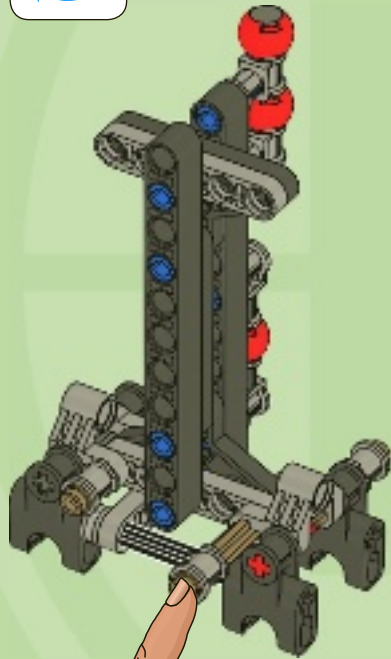

9

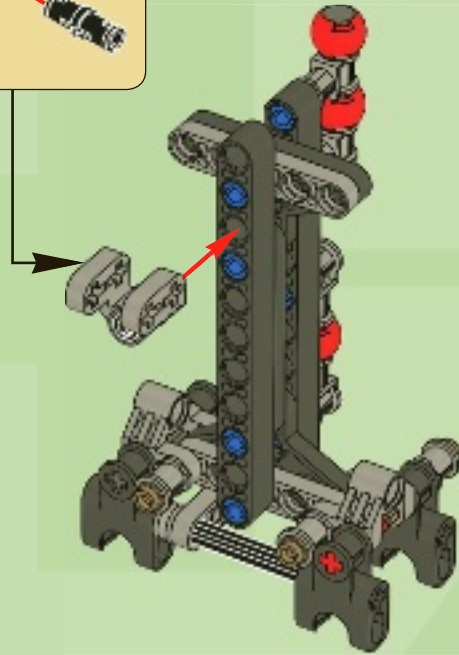
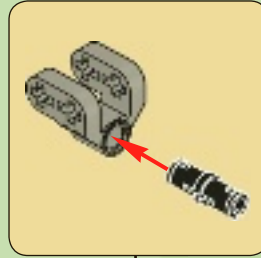

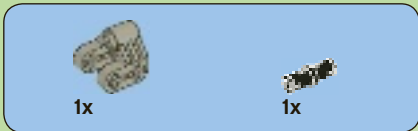

10

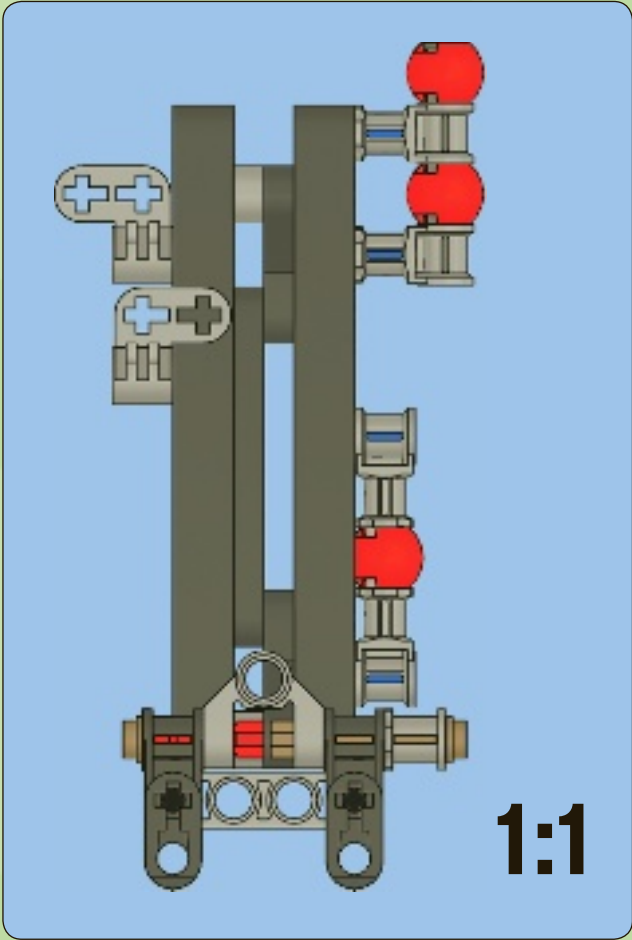
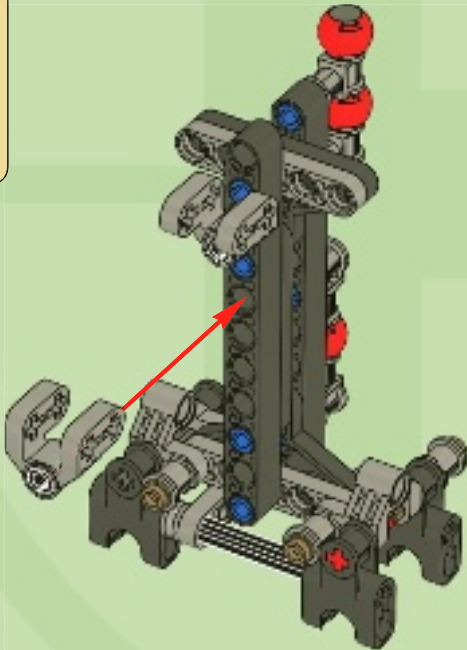
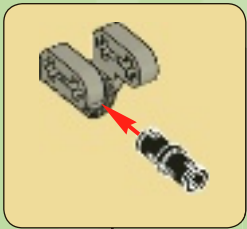

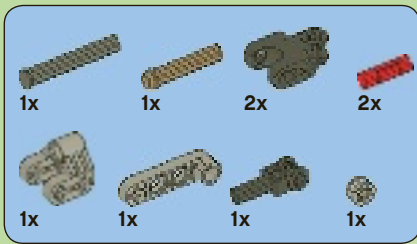

11

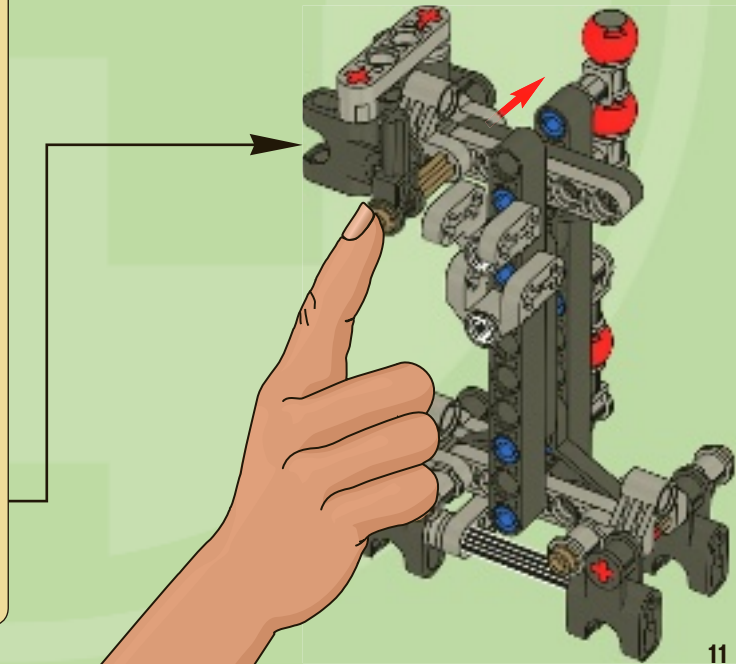
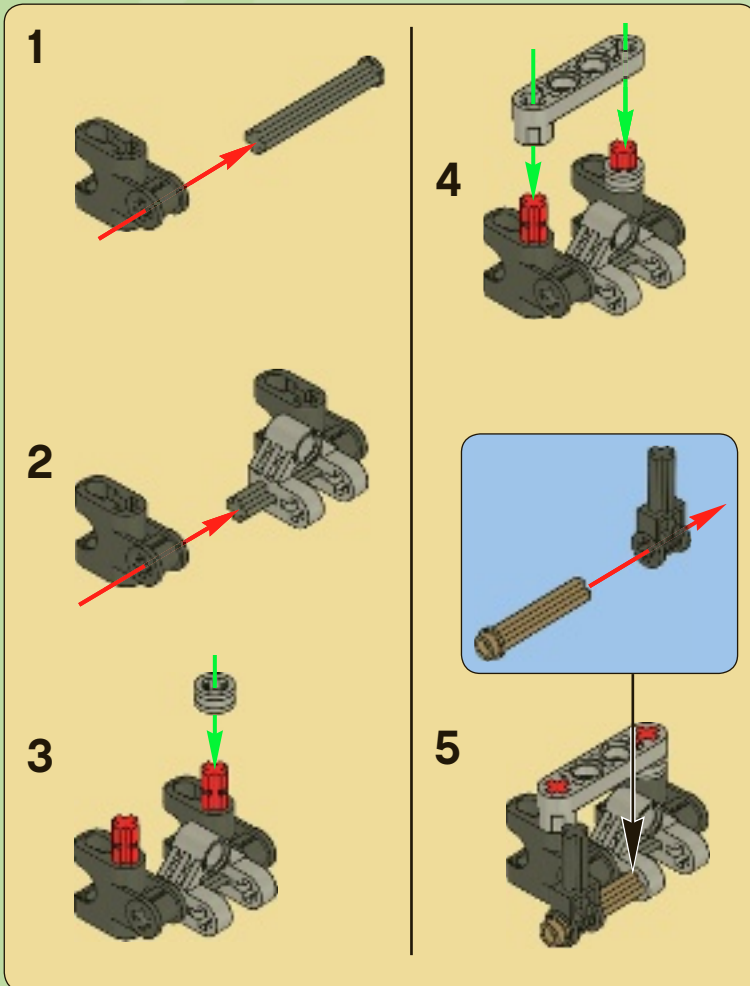

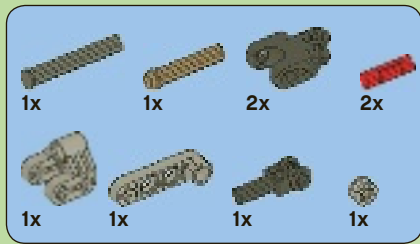

12

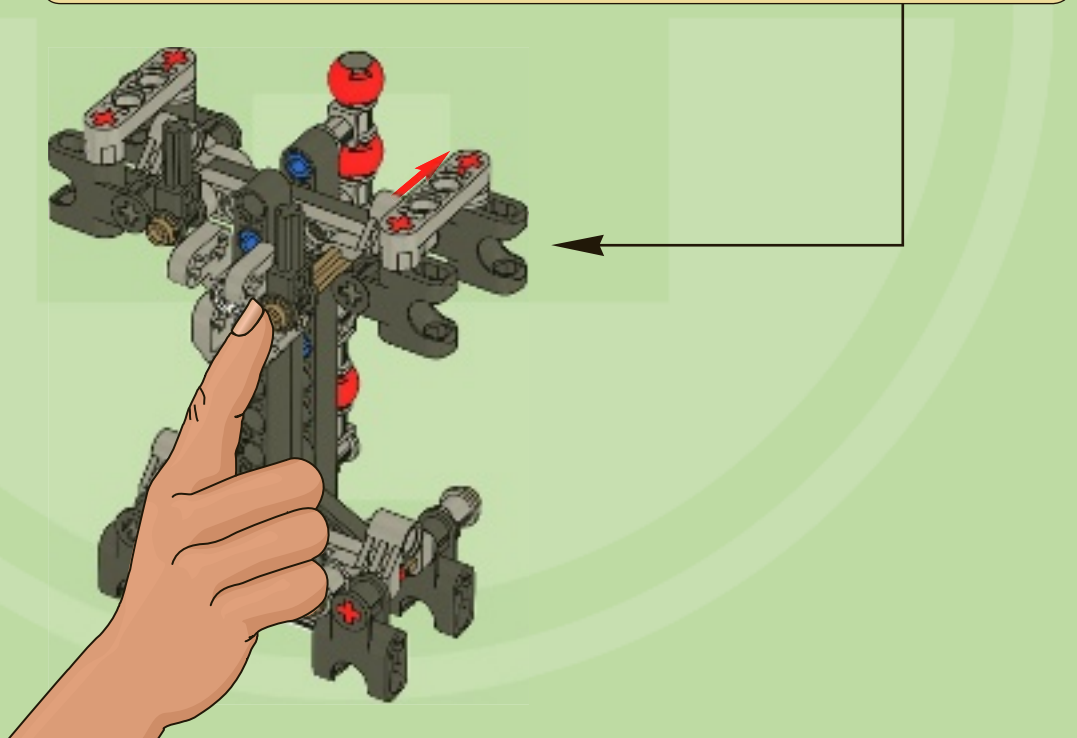
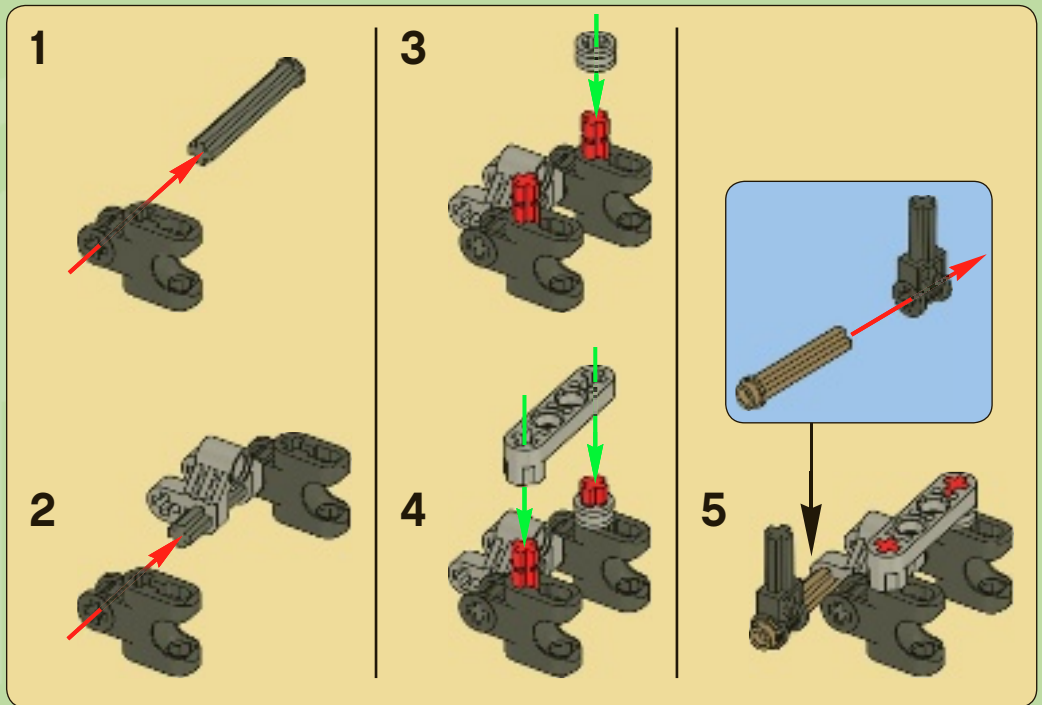

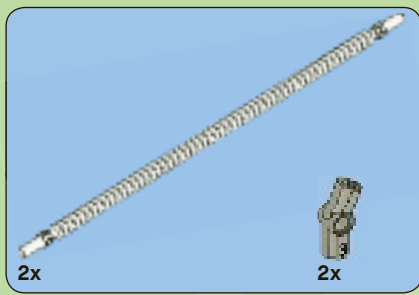

13

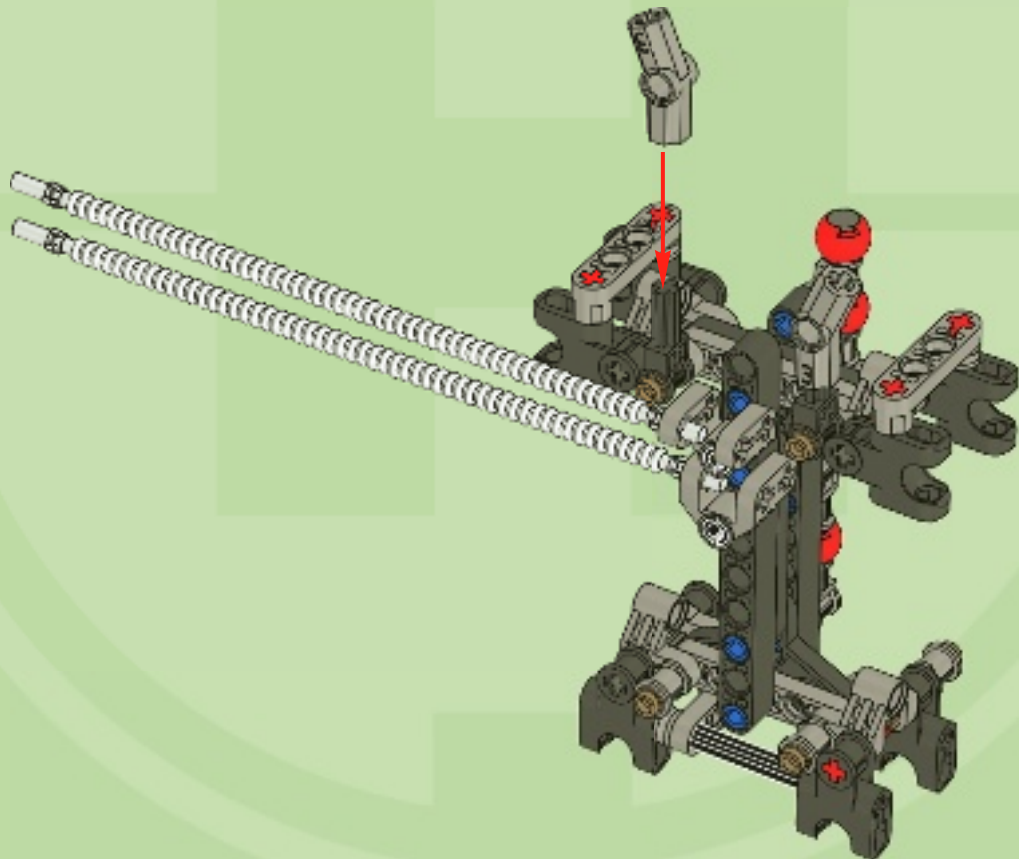

14

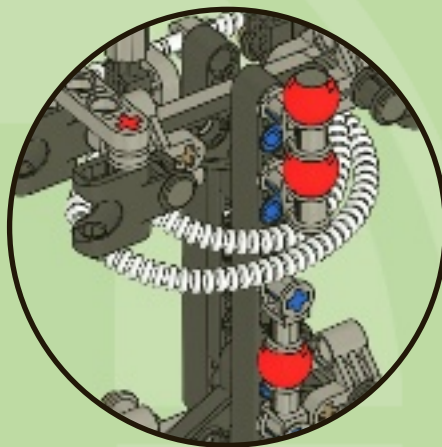
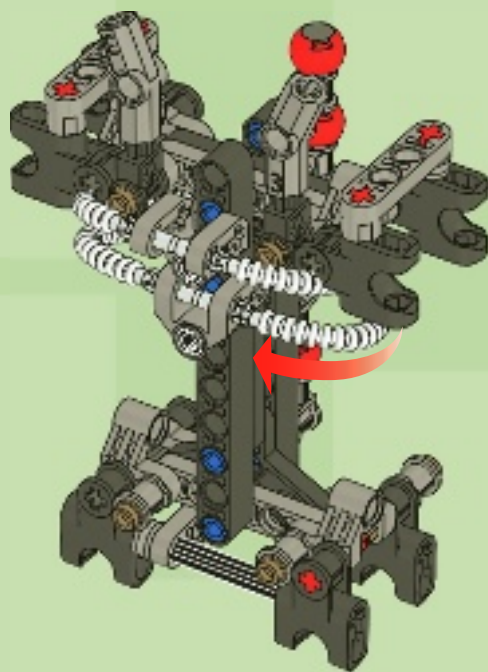

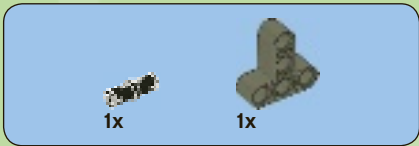
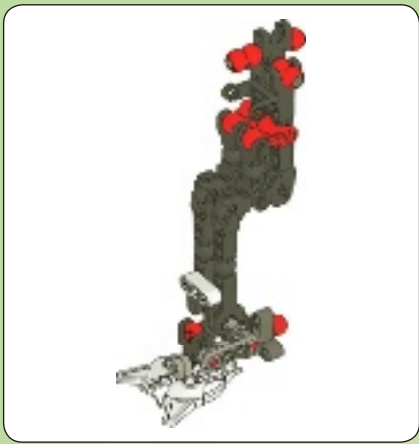

1

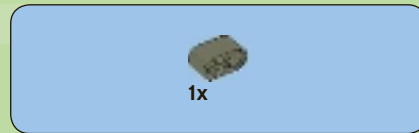

2

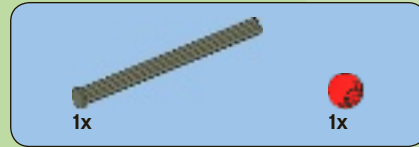
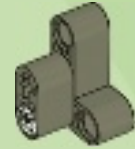

3

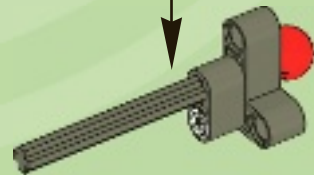
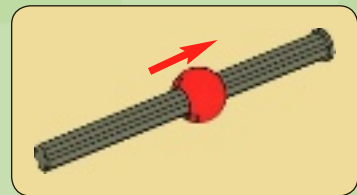

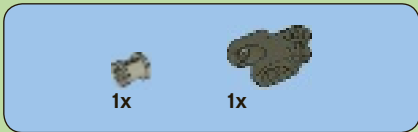

4

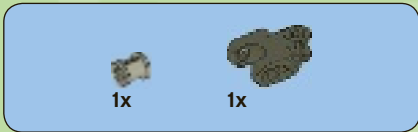
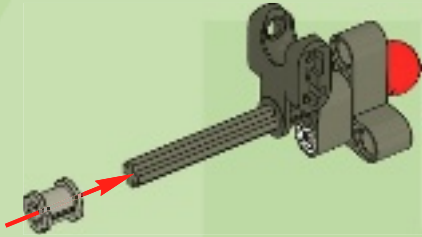

5

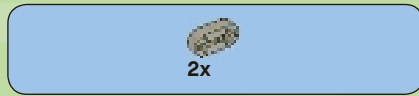
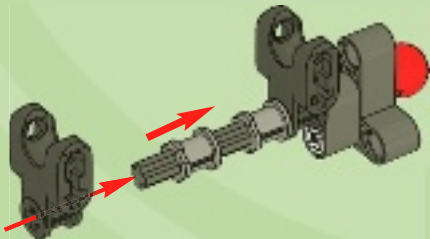

6

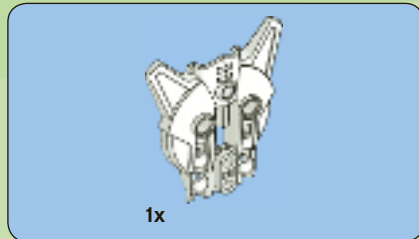
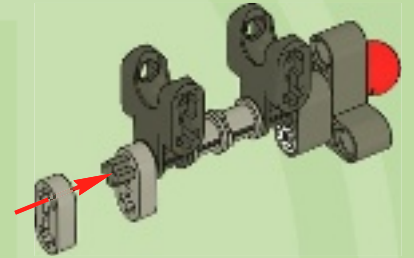

7

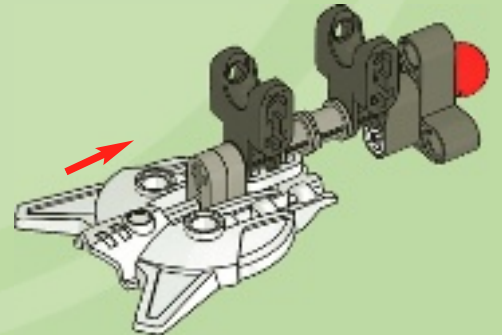

2x

1x

8

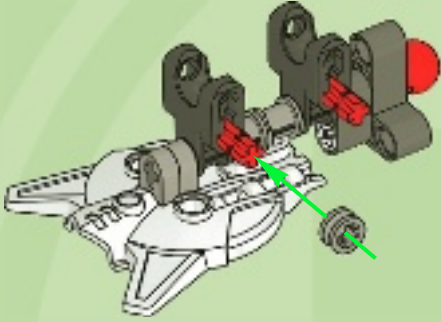

1x

9

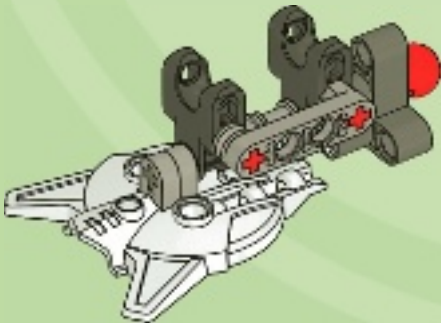

4x

2x

1x

1x

1x

10

1

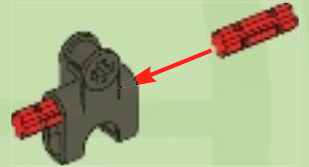

2



3

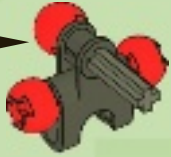
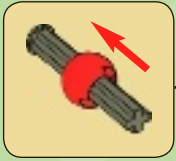

4

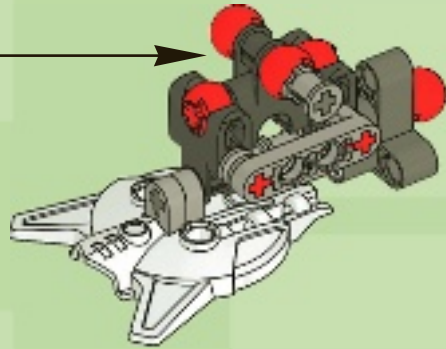
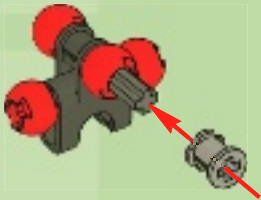

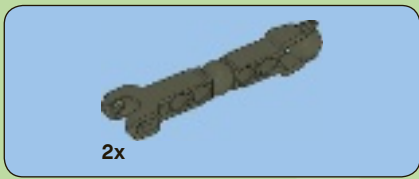

11

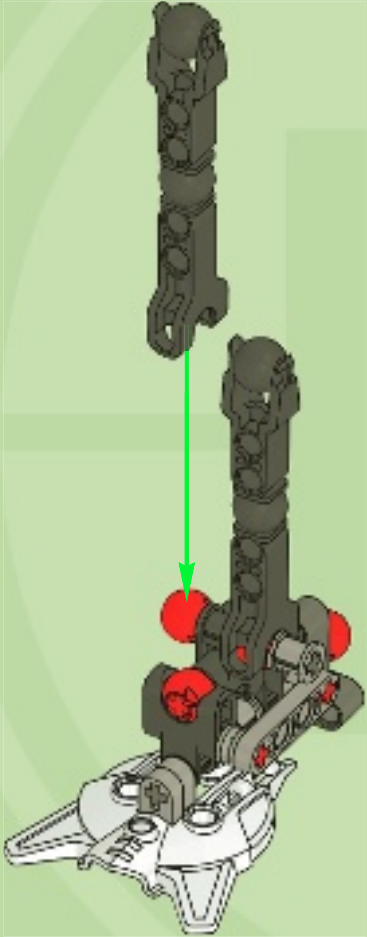

12

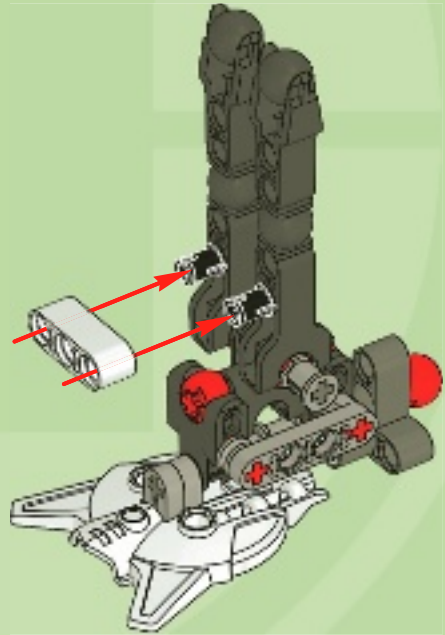

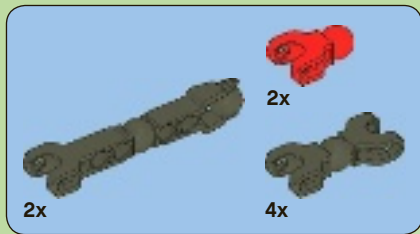

13

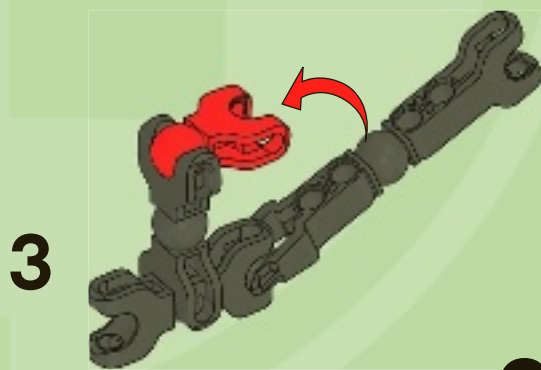
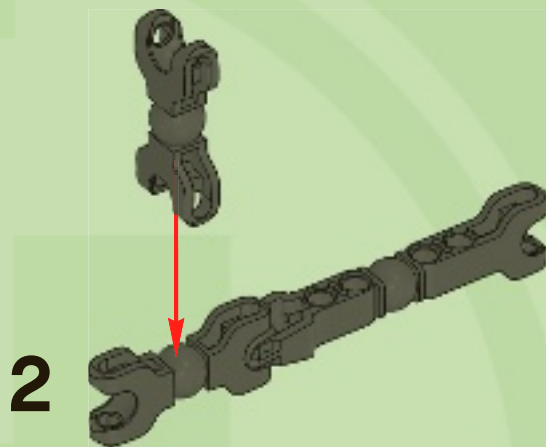
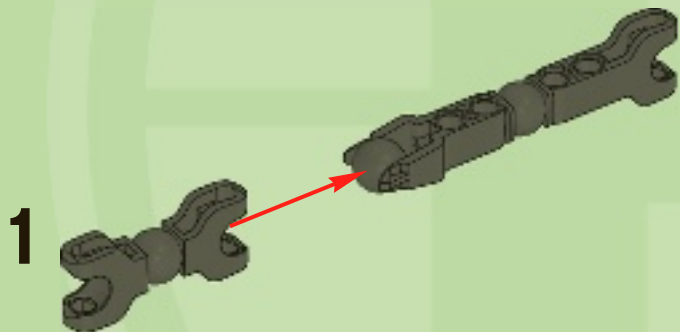

2x

14

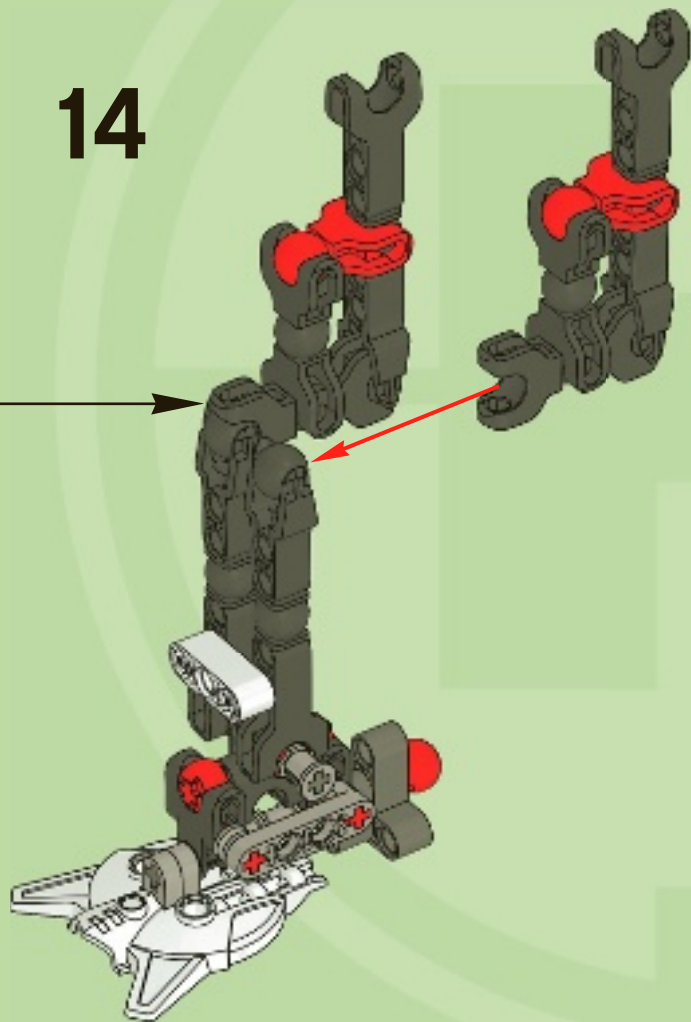

15

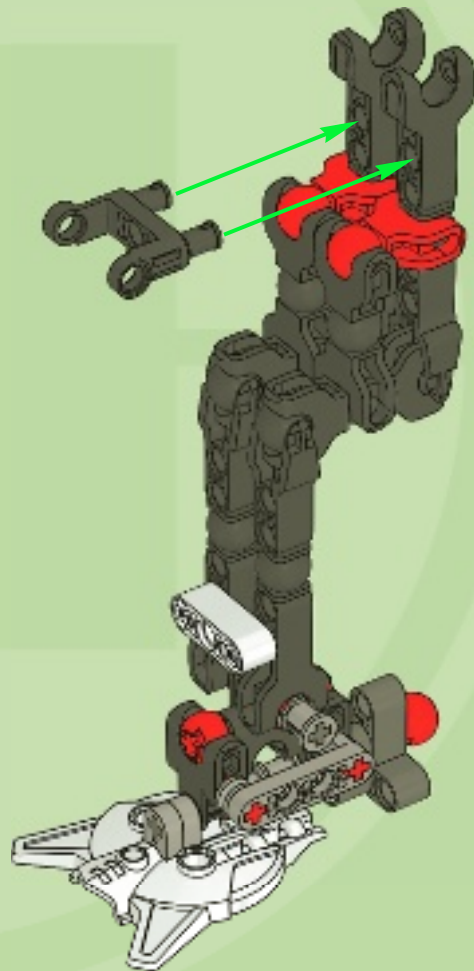

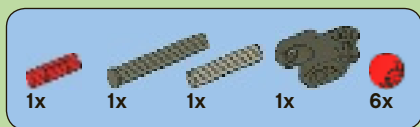

16

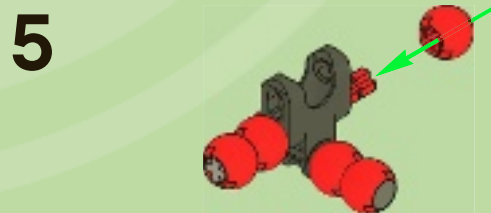
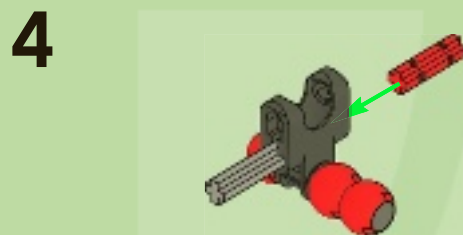
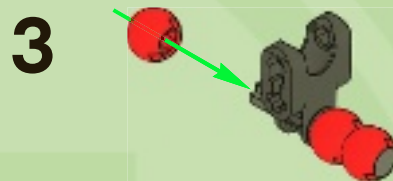
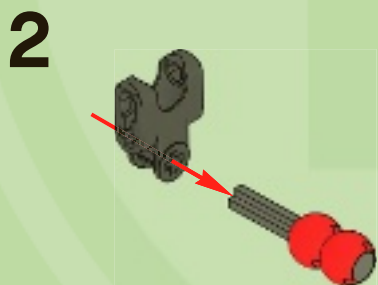
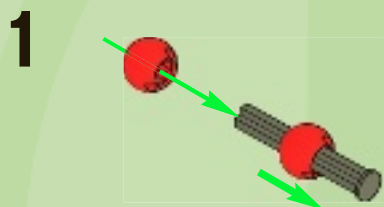

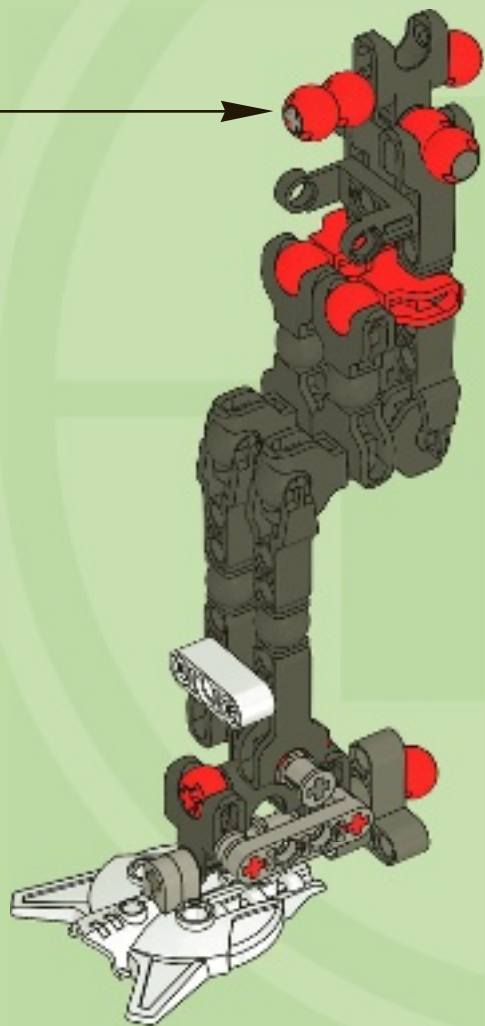

17

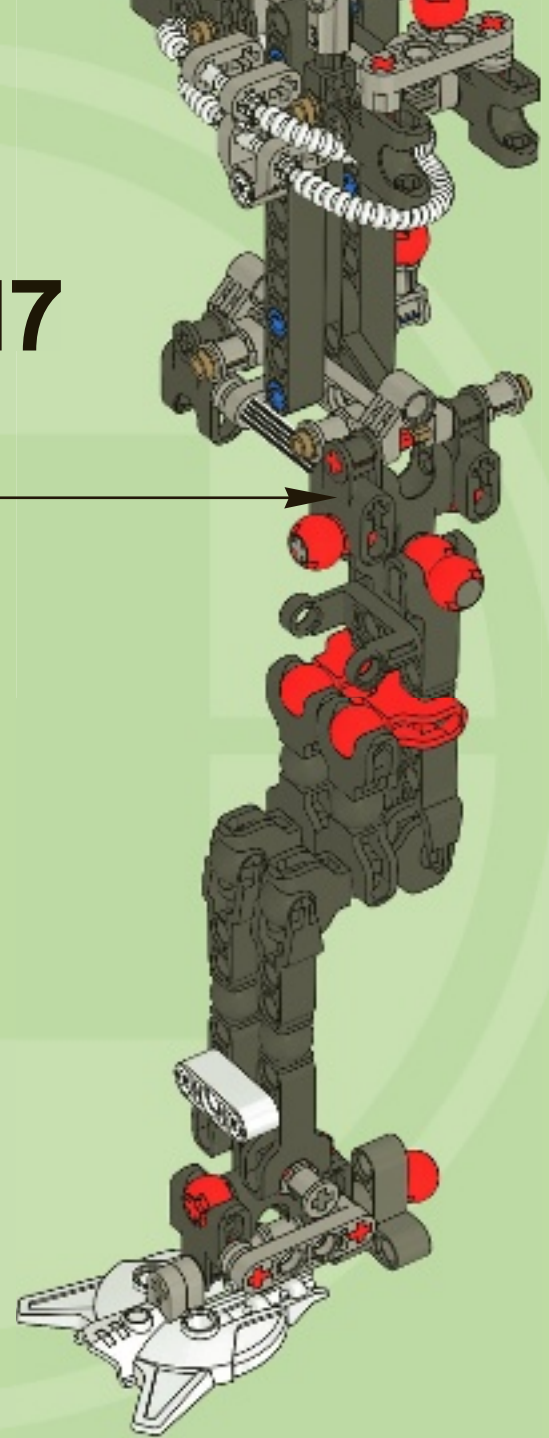

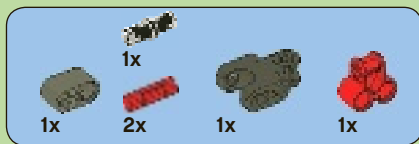

18

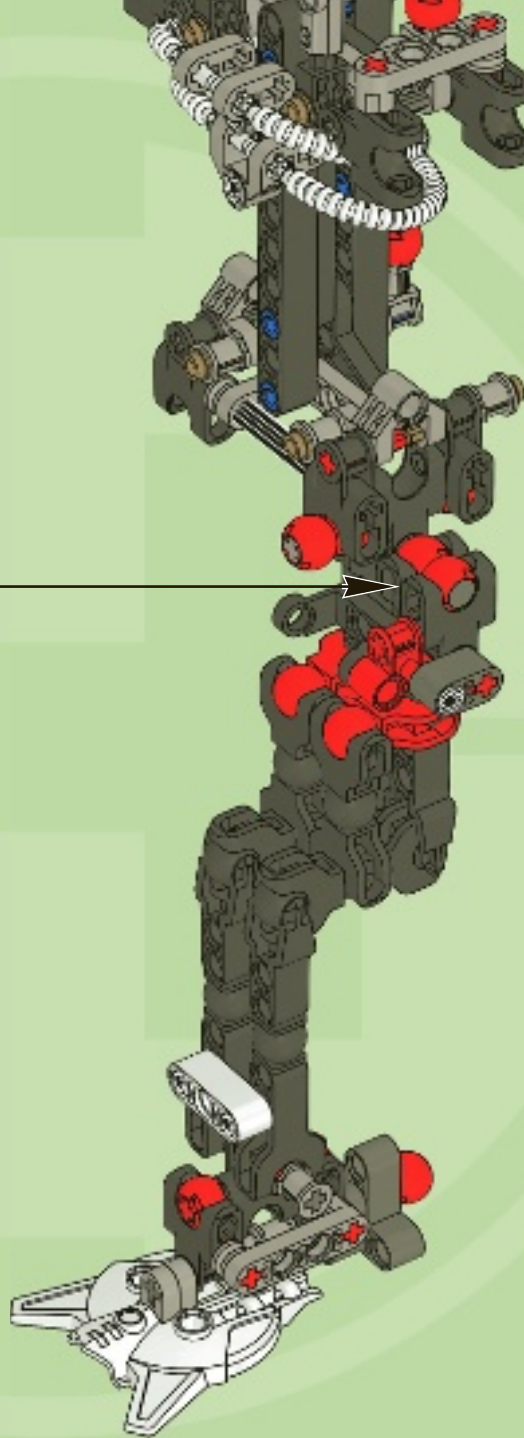

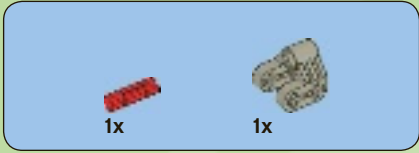

1

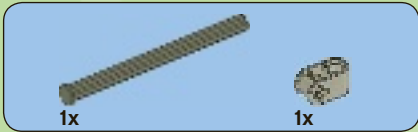

2

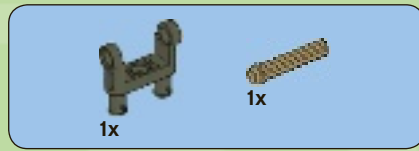
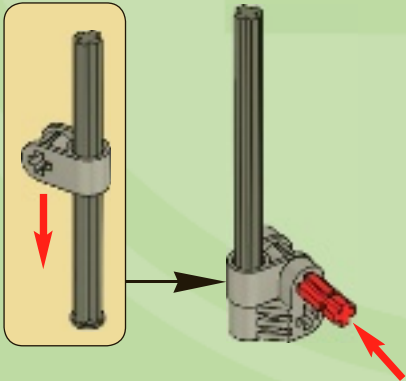

3

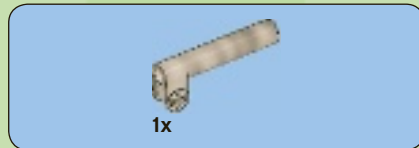
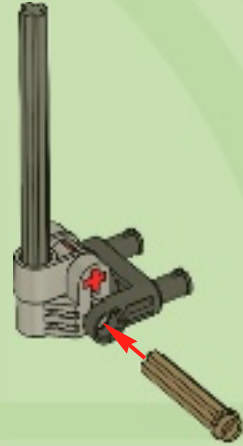

4

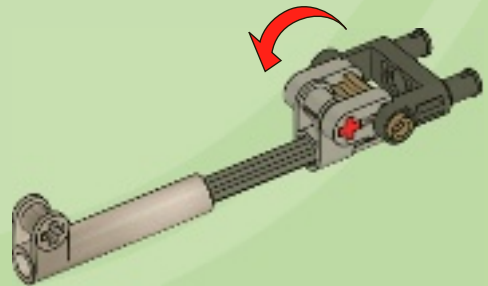

19

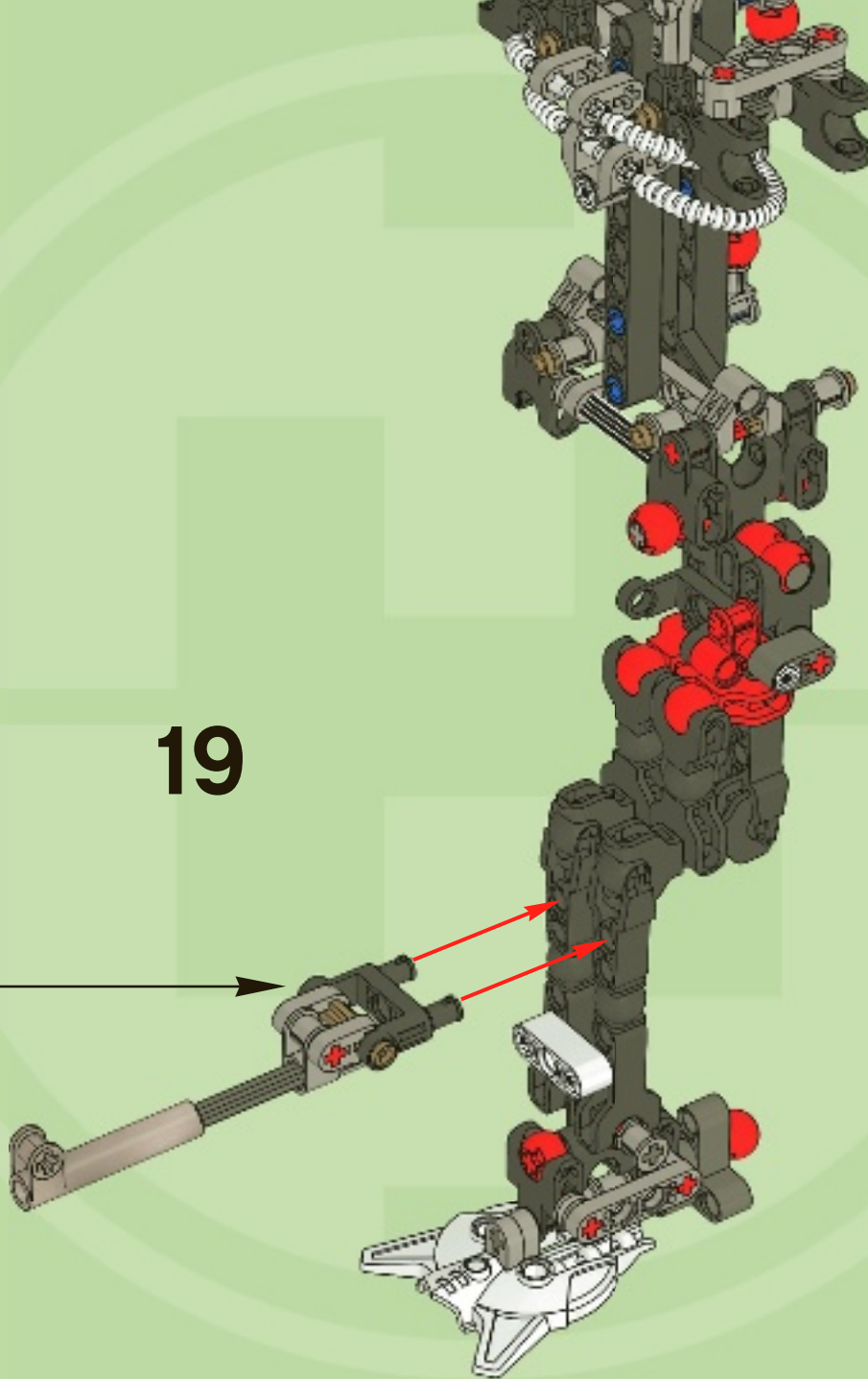

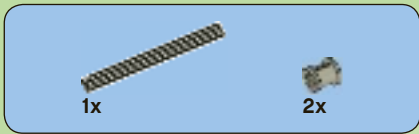

20

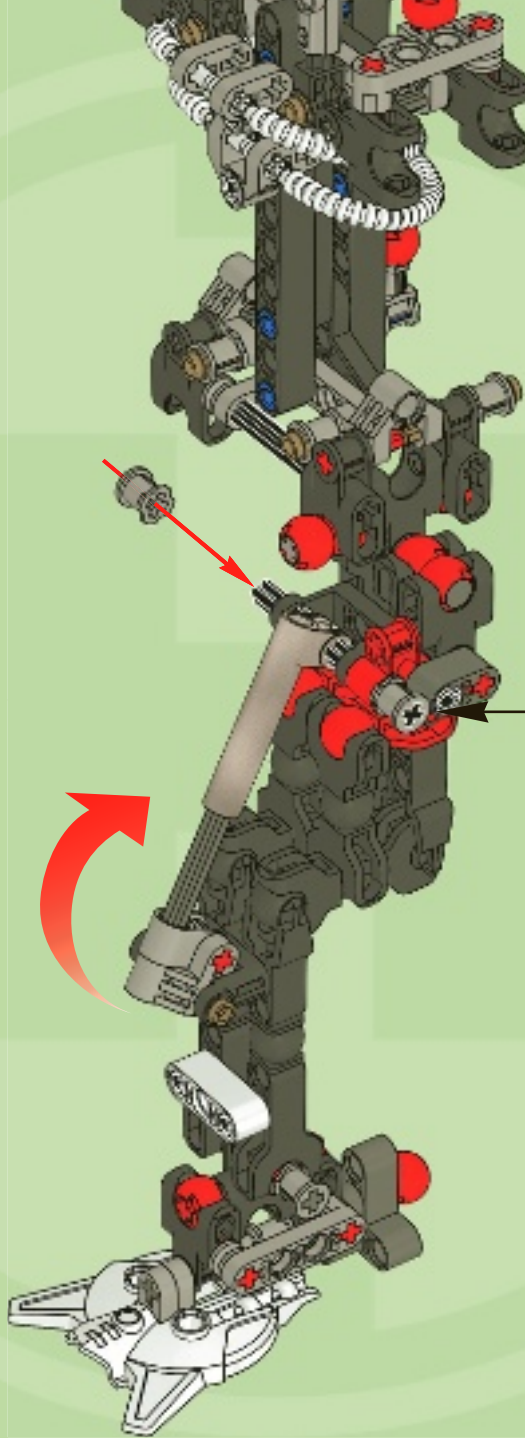



1

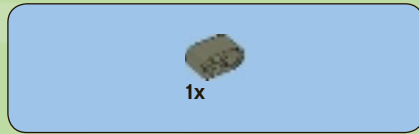

2

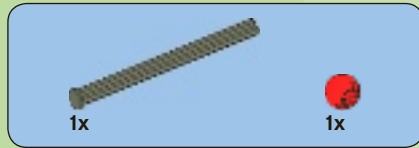
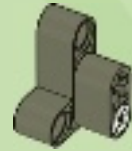

3

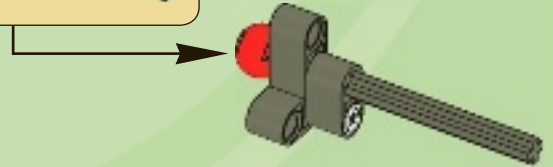
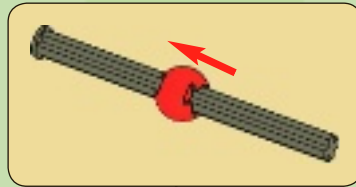

1x



1x

4

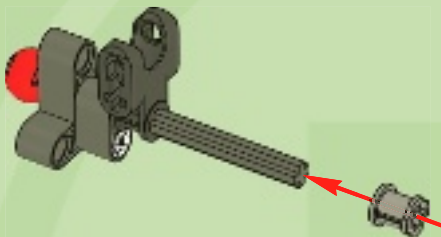

1x



1x

5

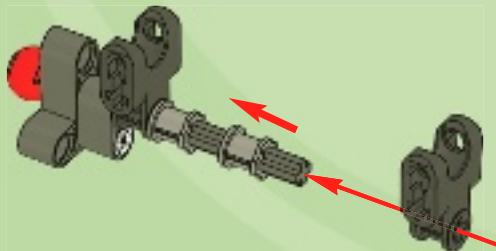

2x

6

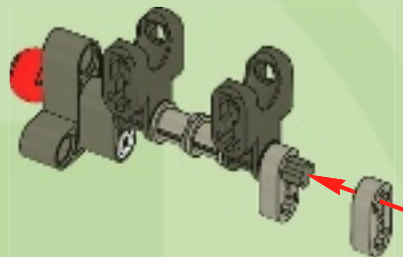

1x

7

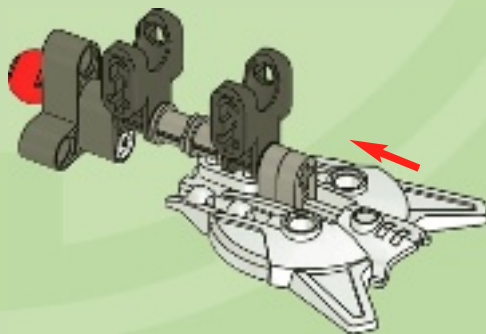



2x



1x

8

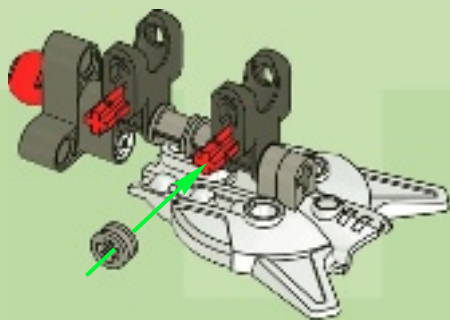

1x

9

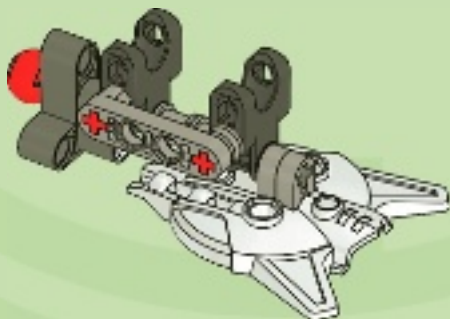

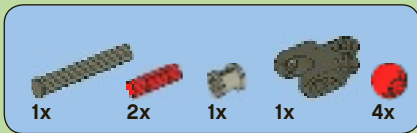

10

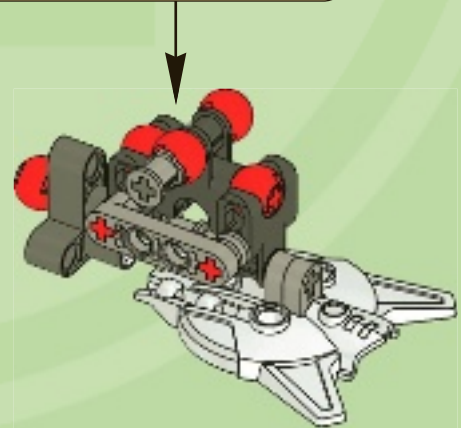
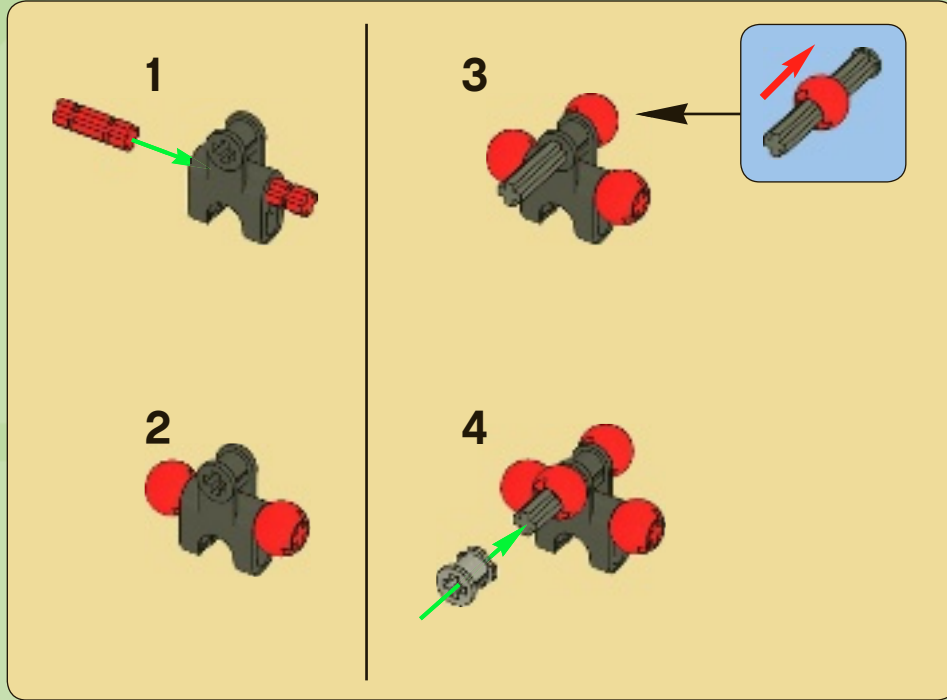

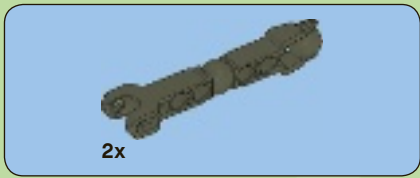

11

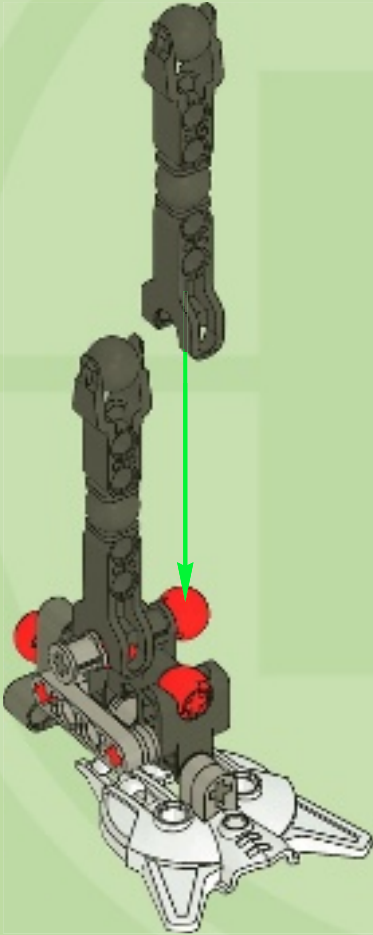

12

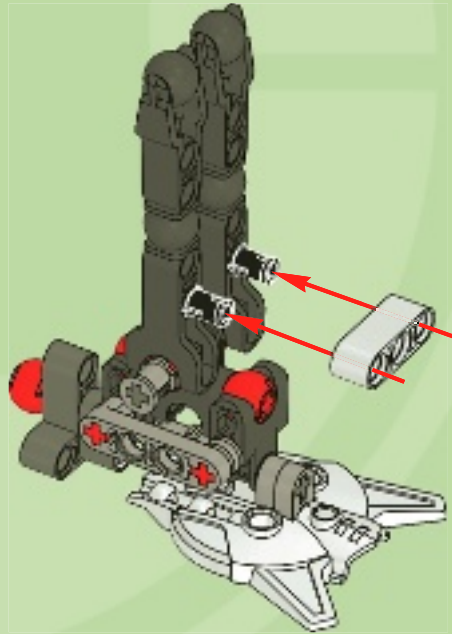

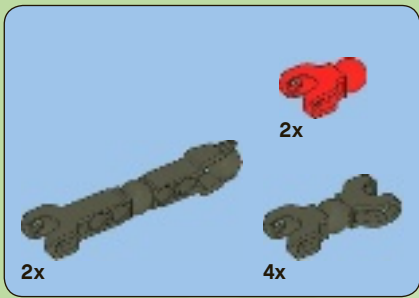

13

1

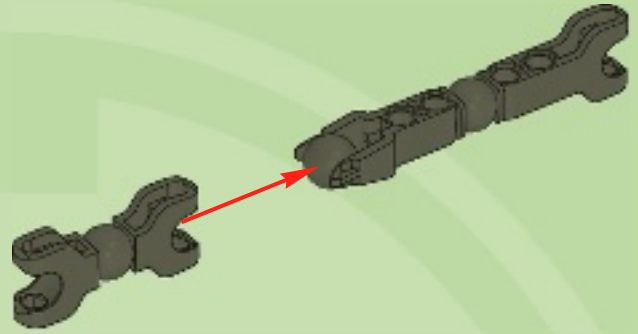

2

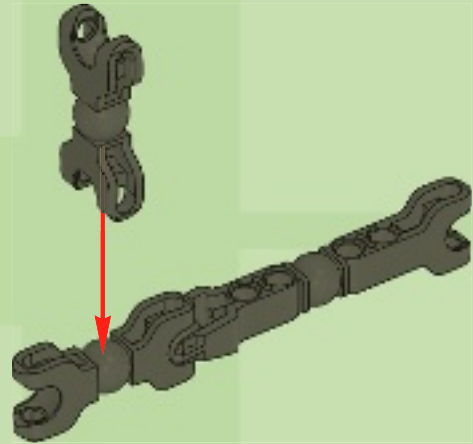

3

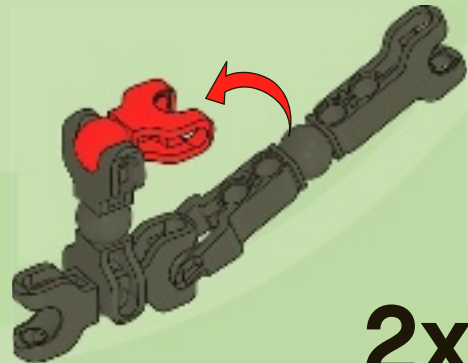

2x



14

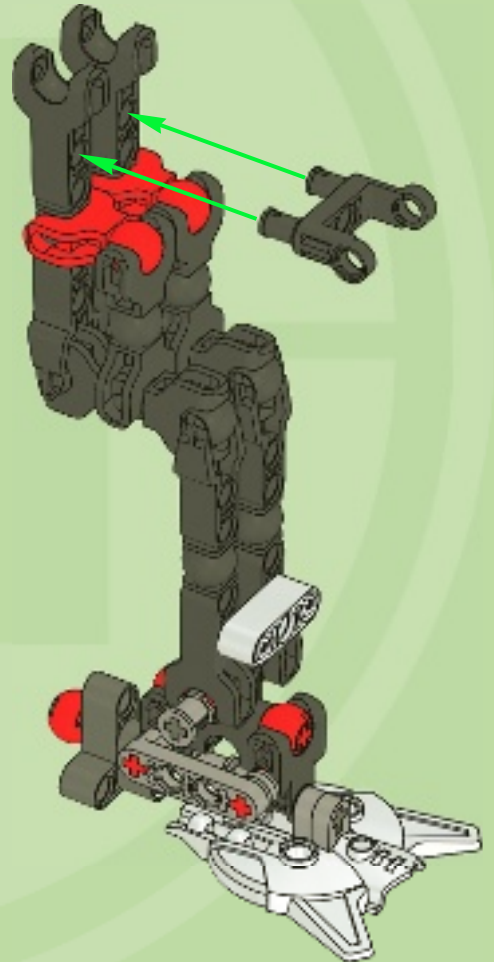
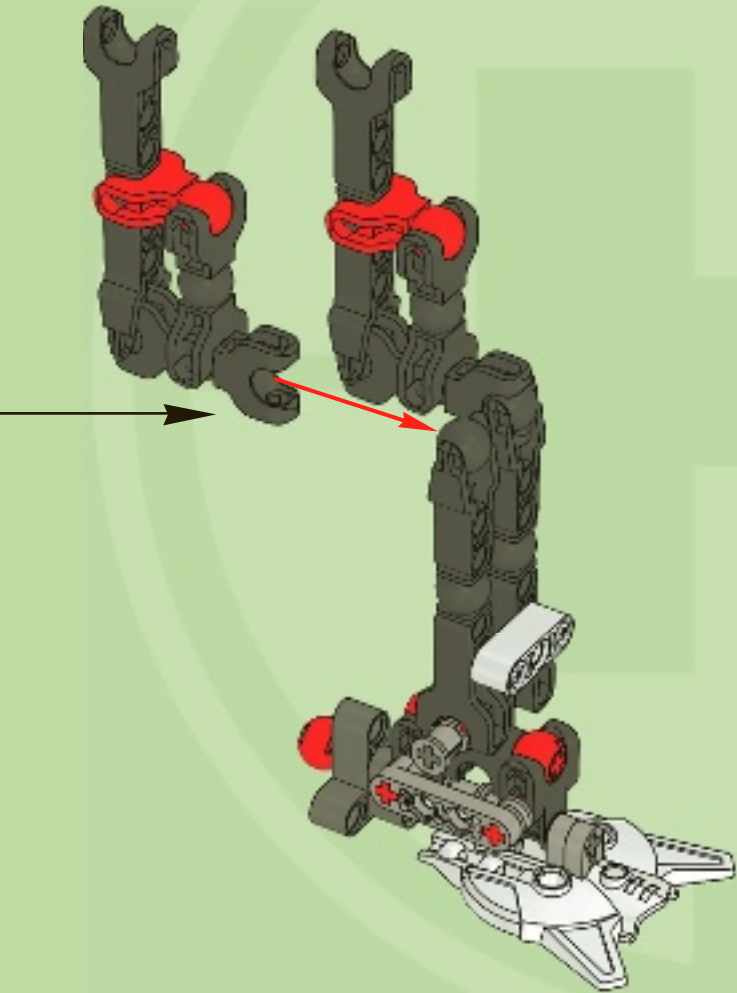

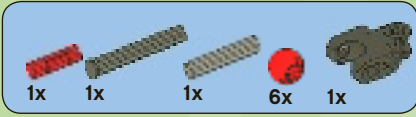

15

1

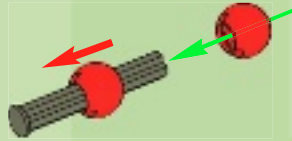

2

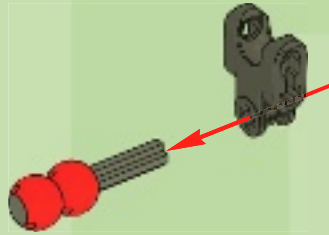

3

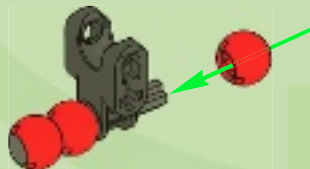

4

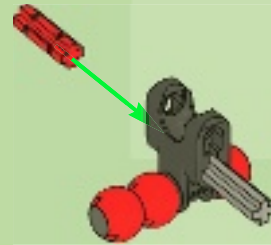

5

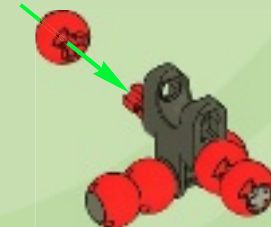

16

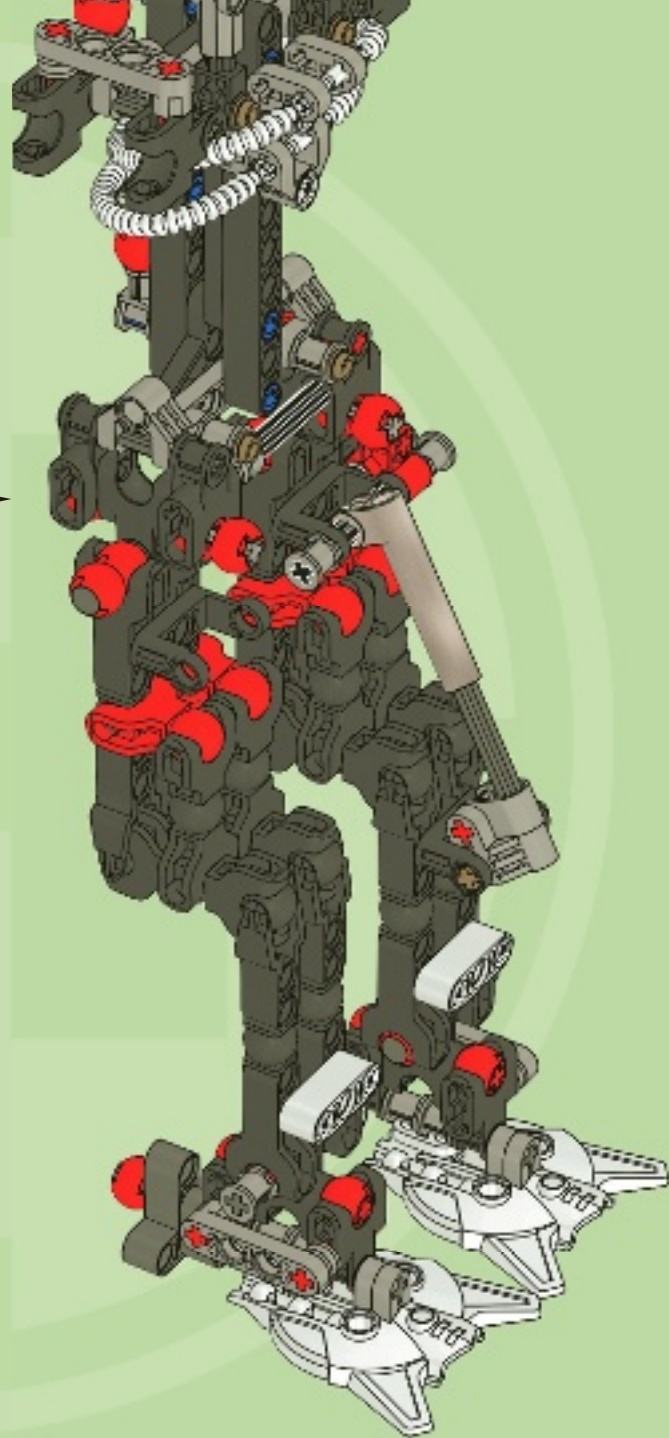
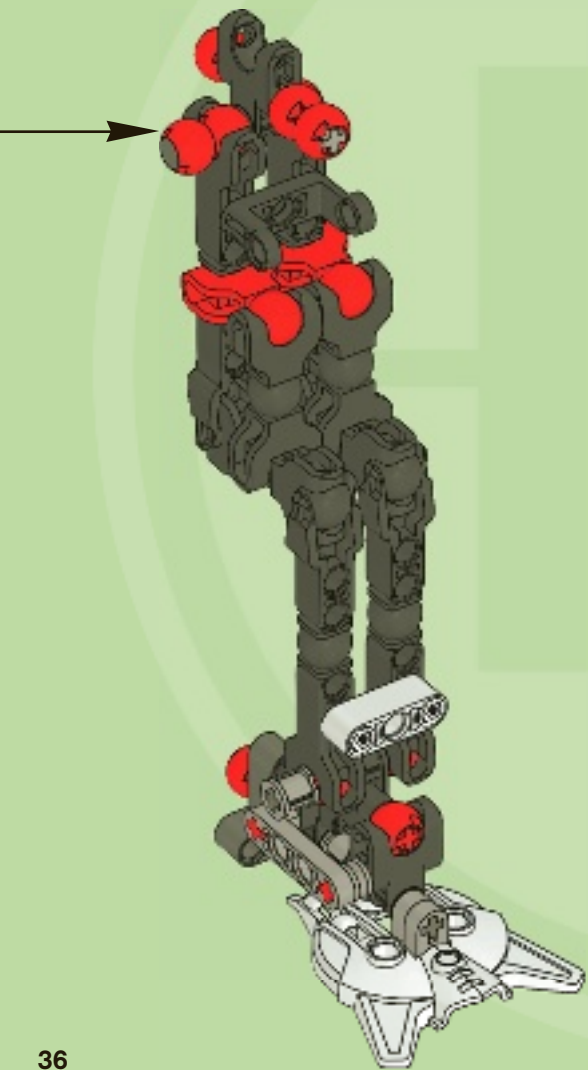

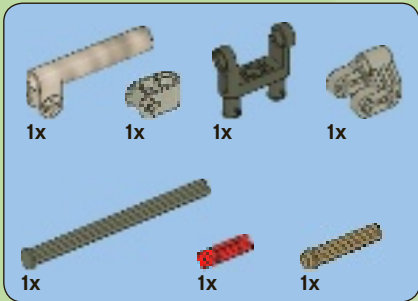

18

1



2

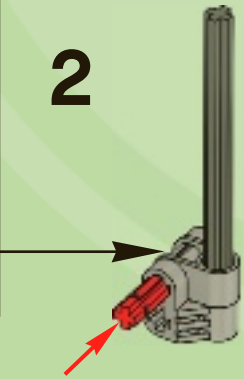
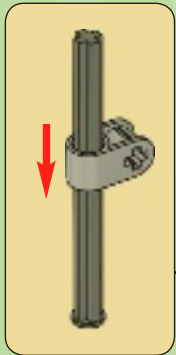

3

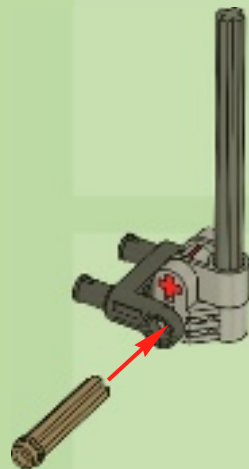

4

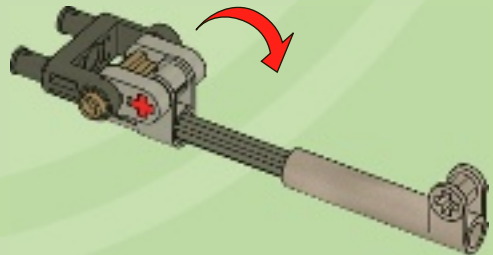

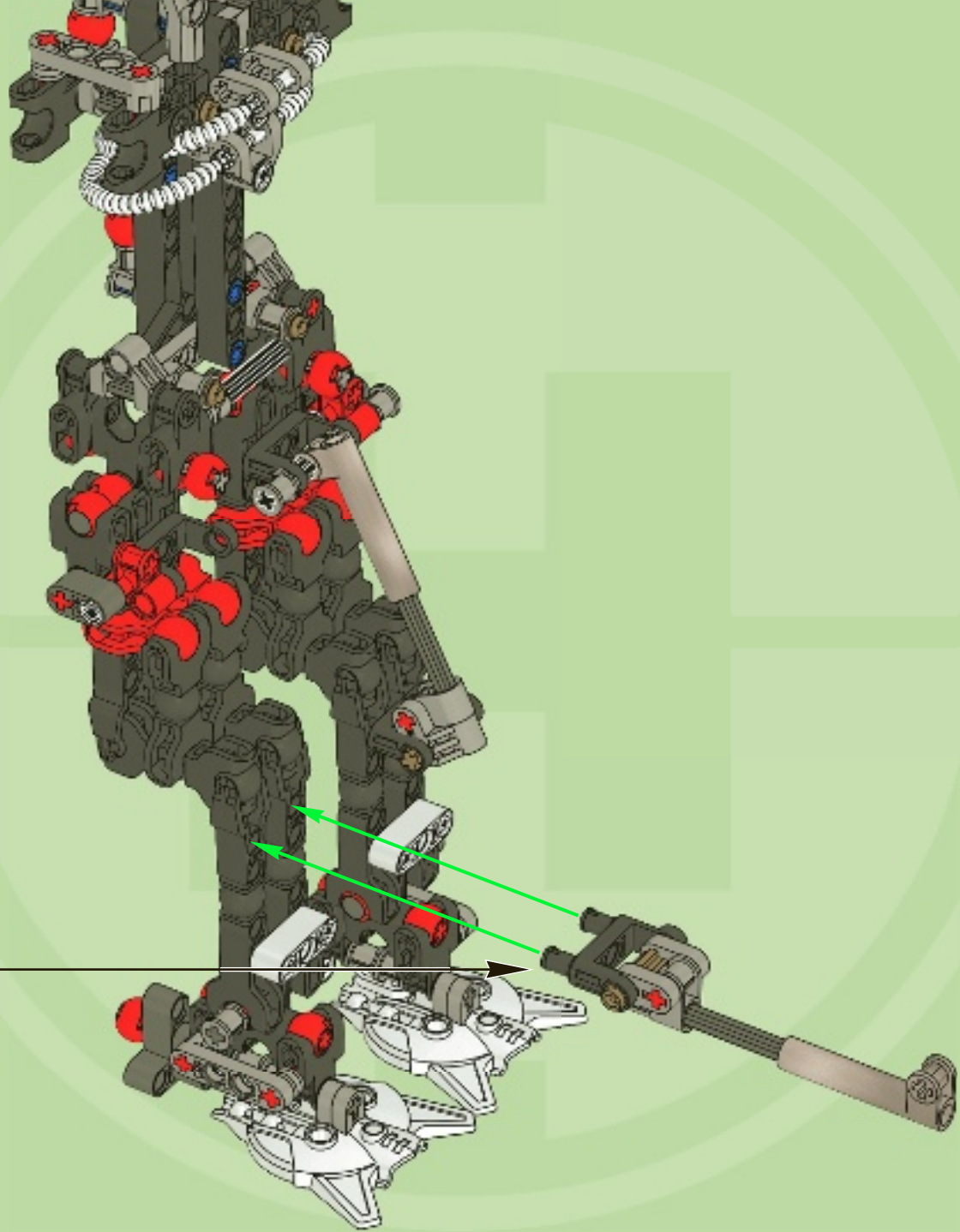



19

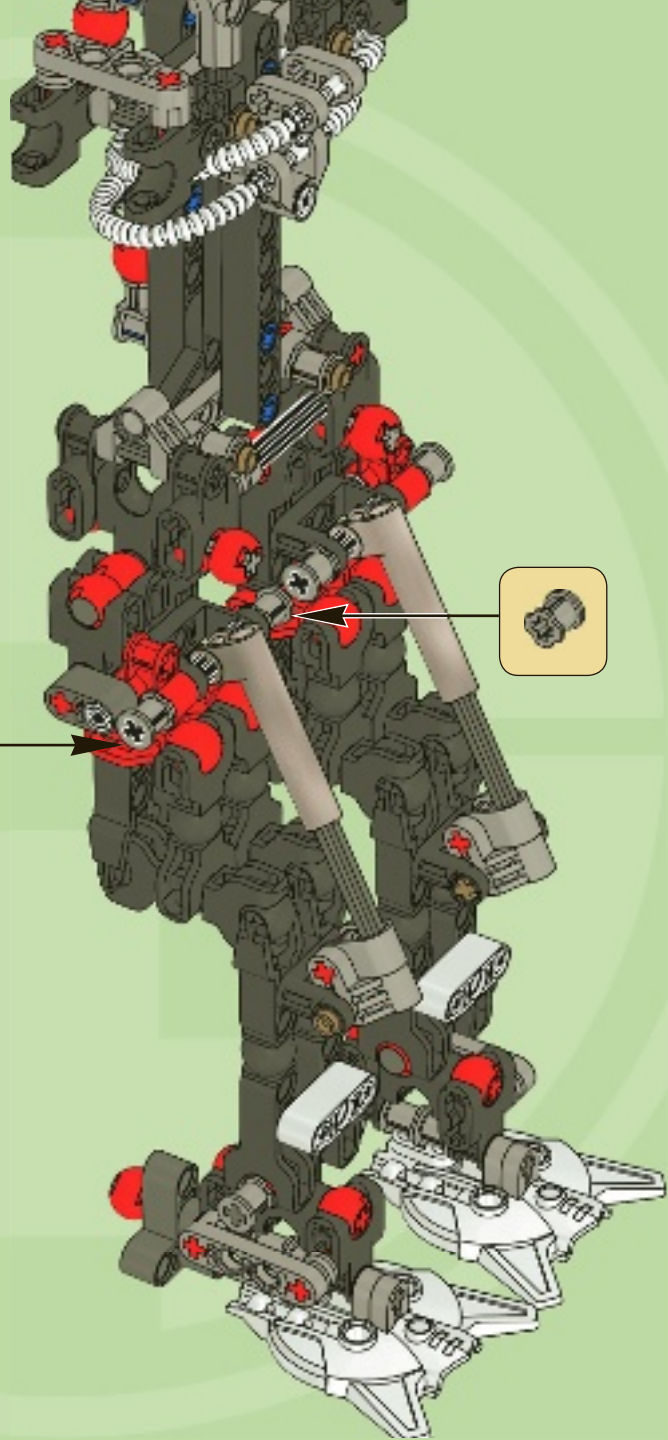



20

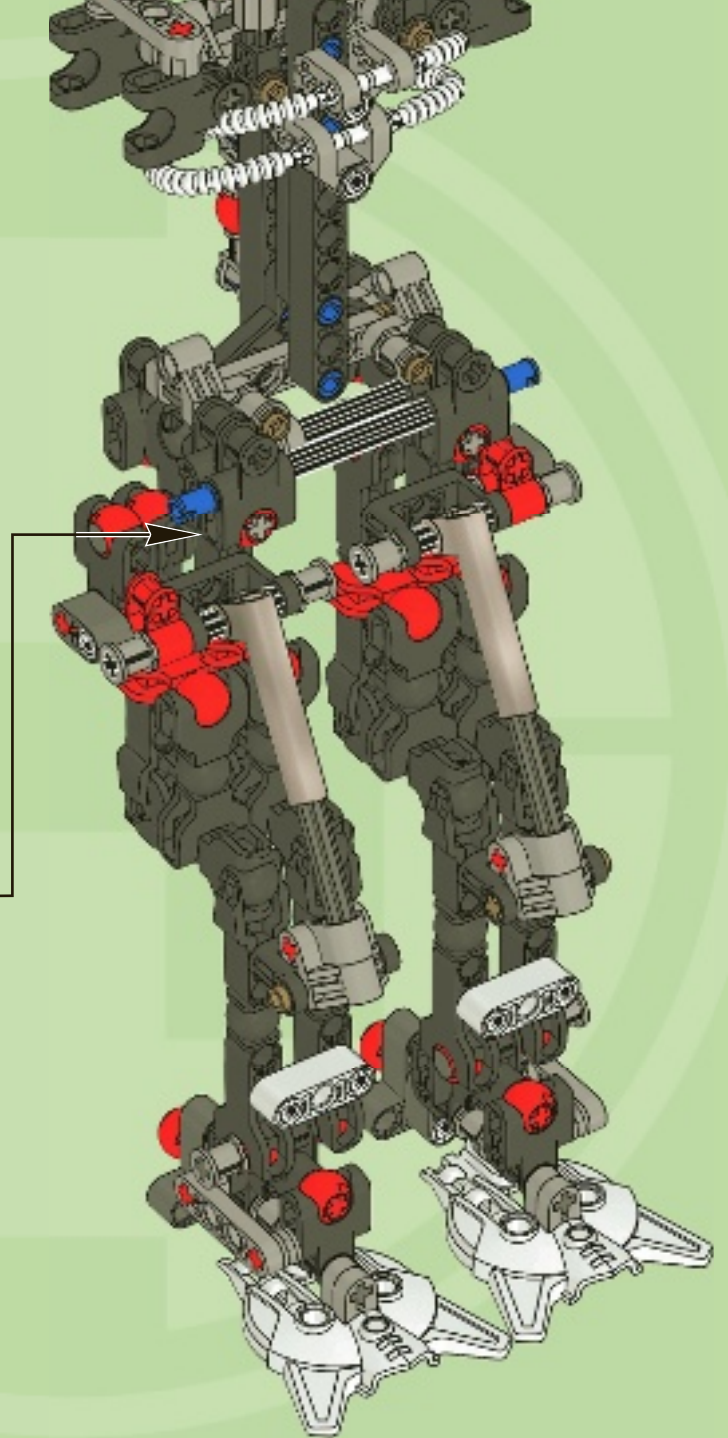
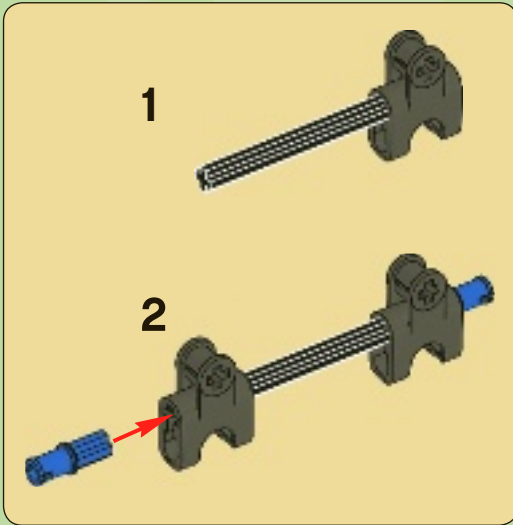



21



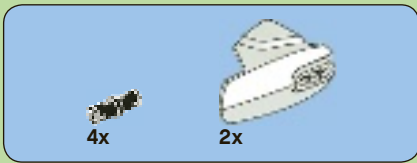

22

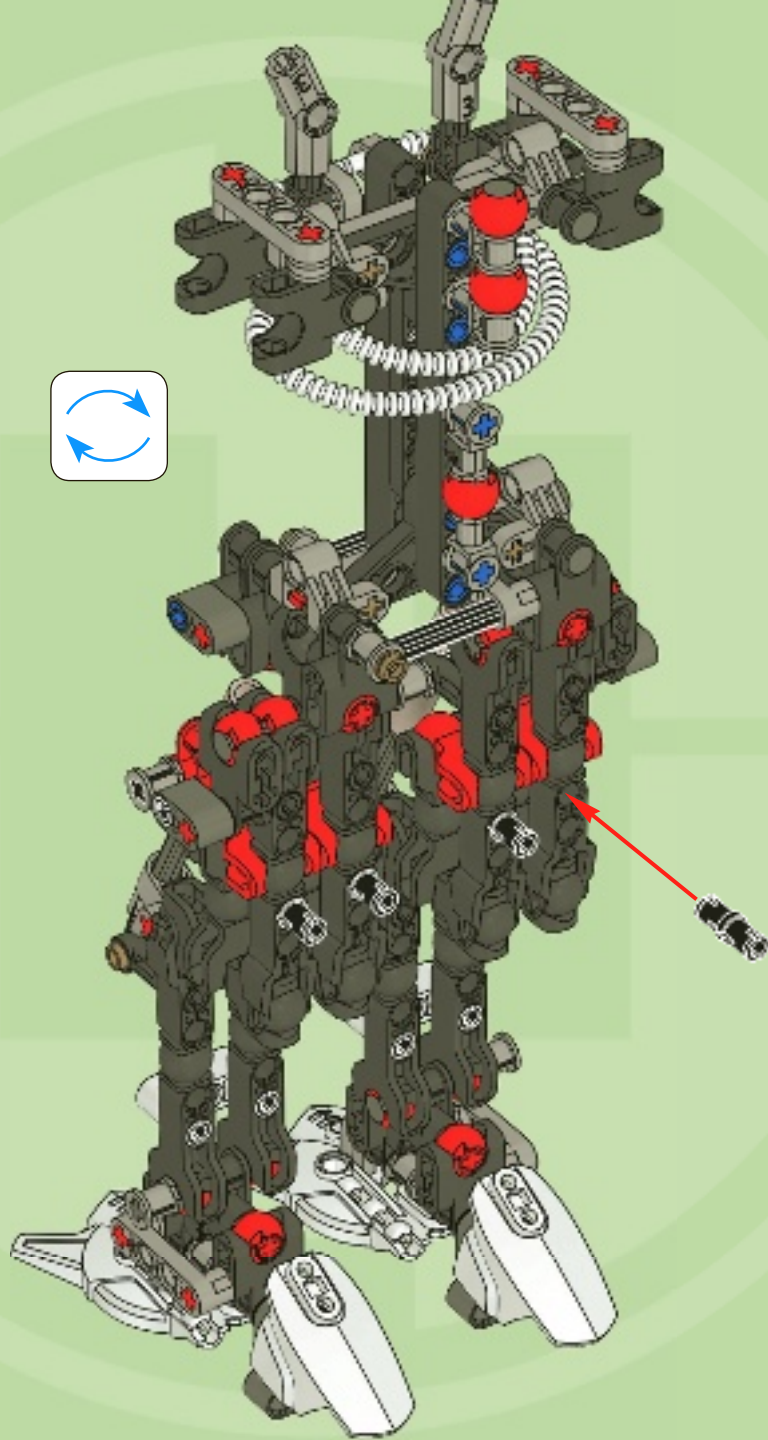

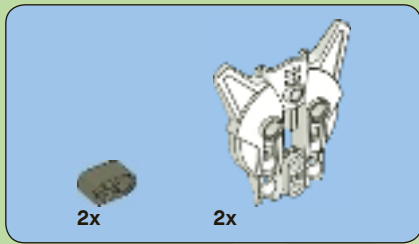

23

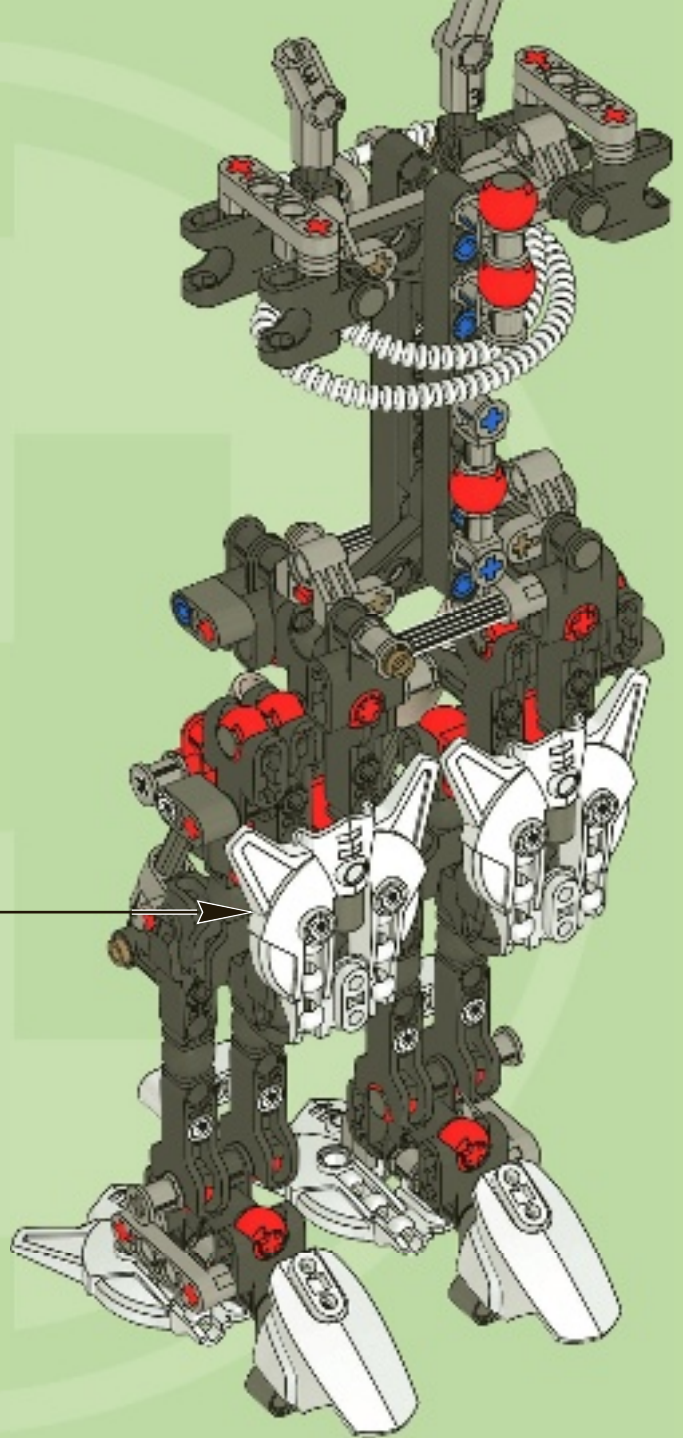
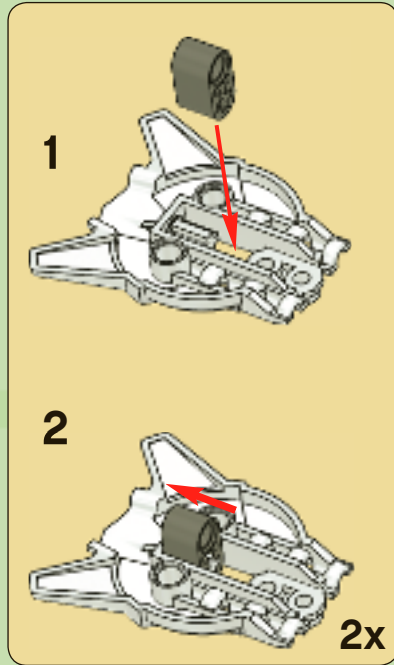

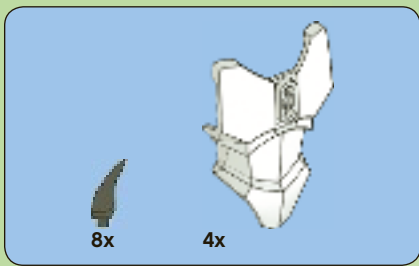

24

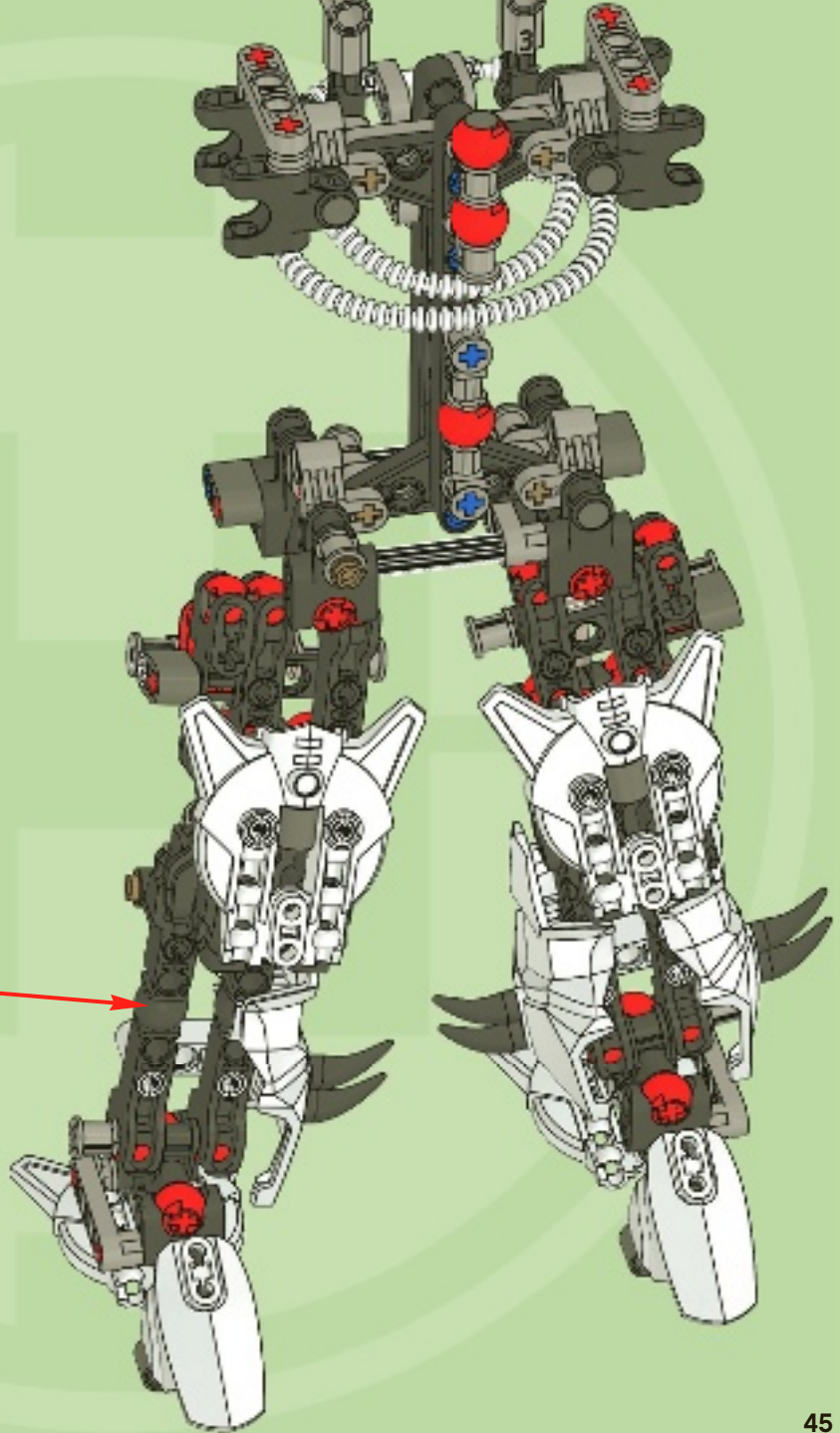
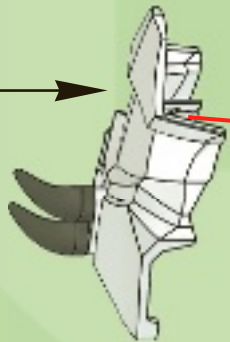
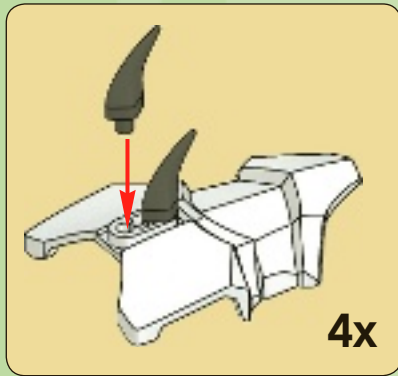



25

1

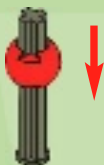

2

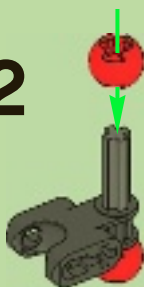

3

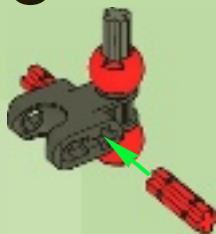

4



2x

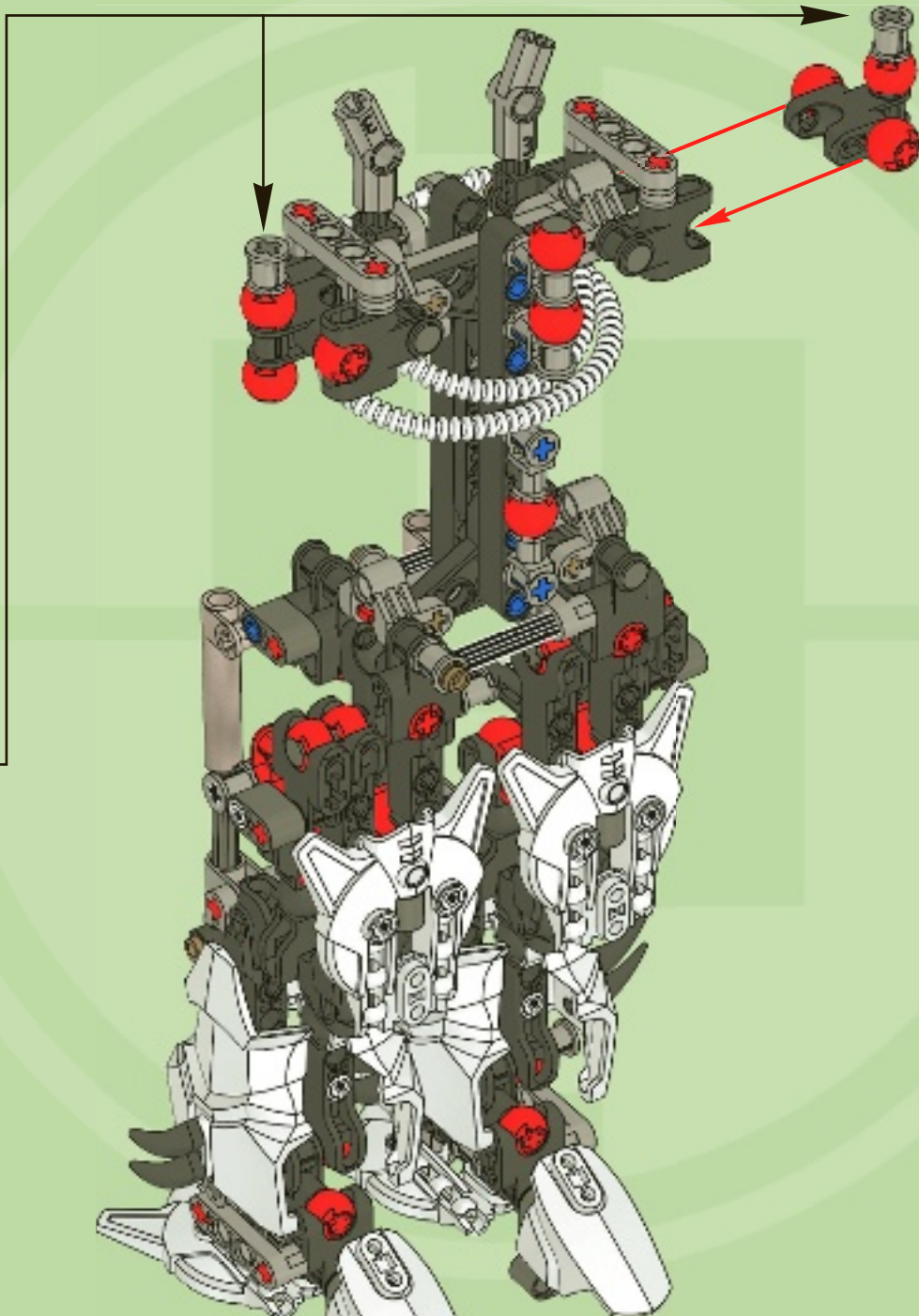

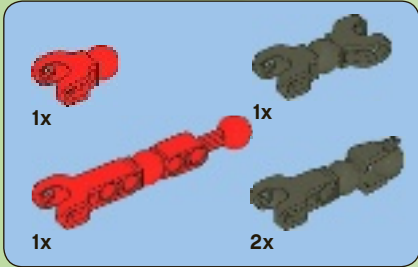
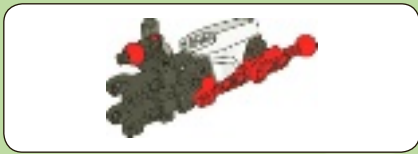

26

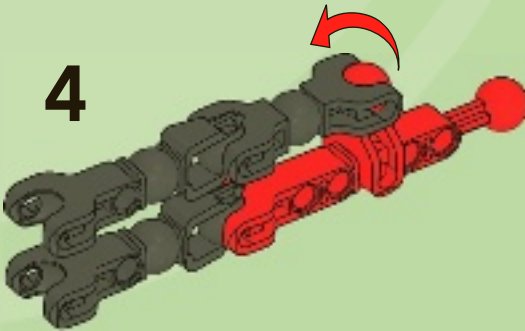
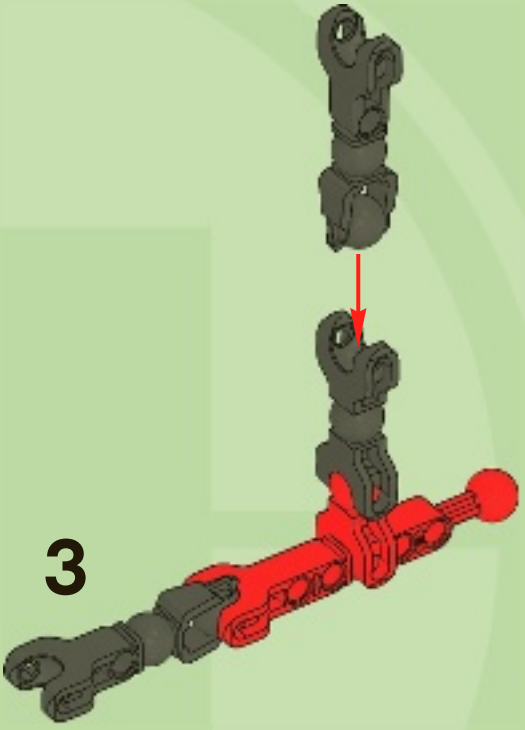
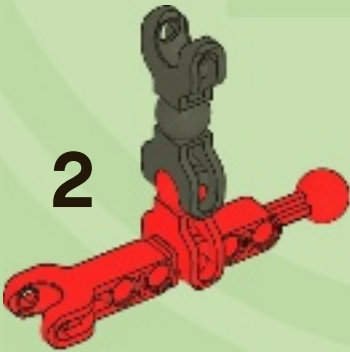
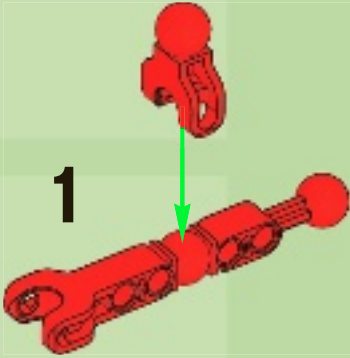

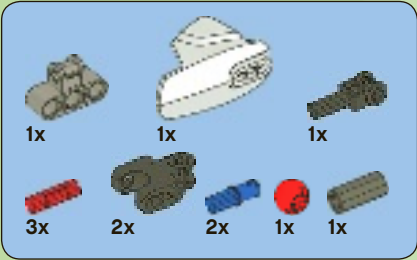

27

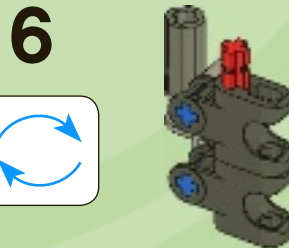
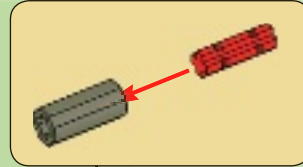
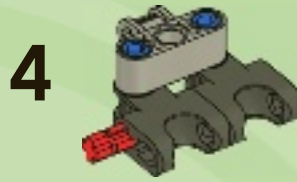
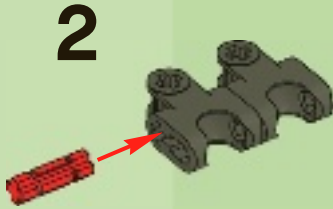
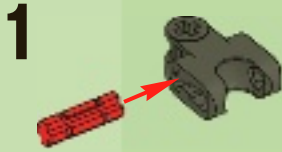

7

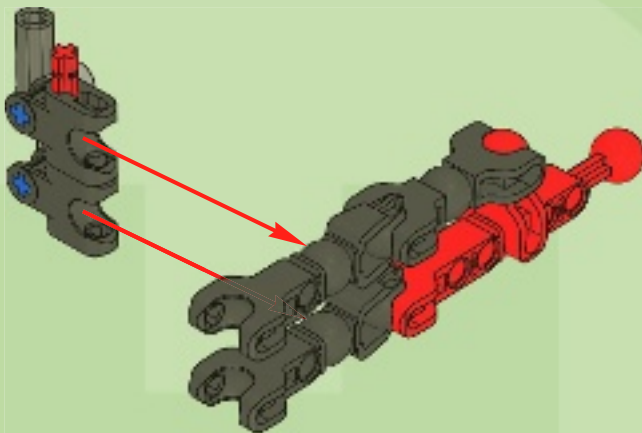

8

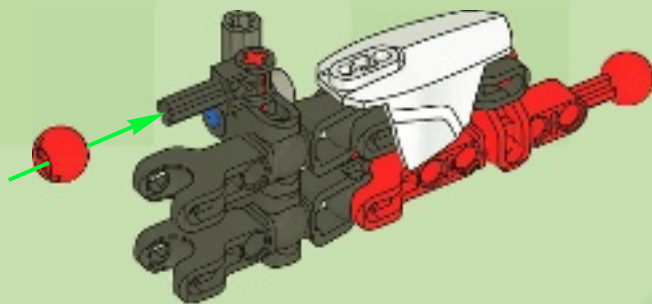

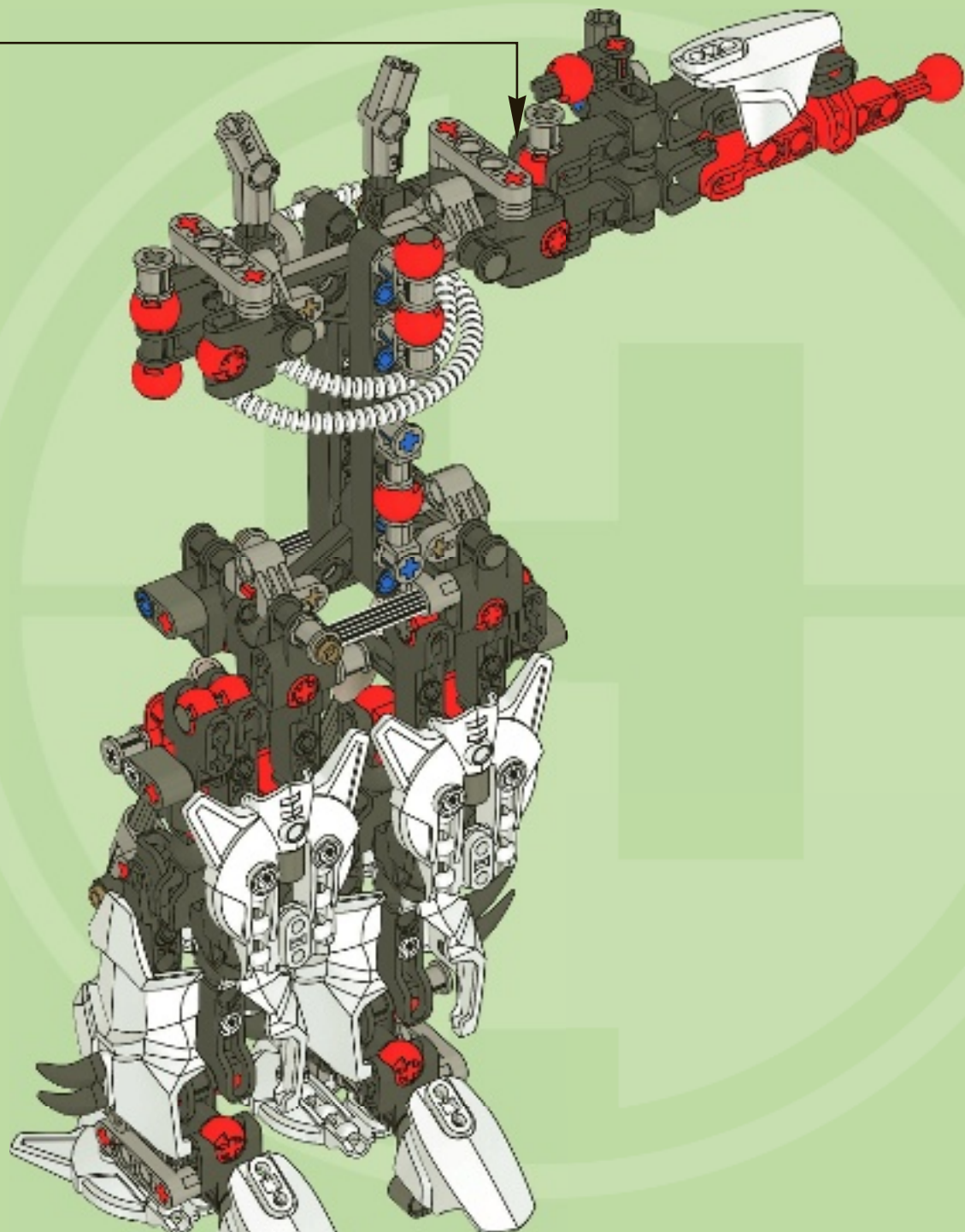

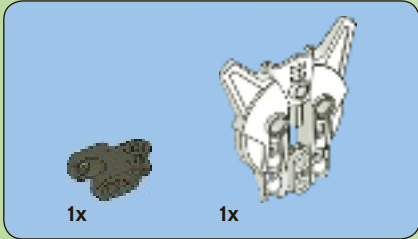

1

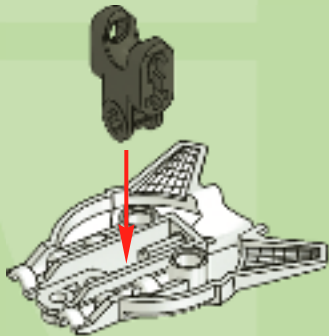

2

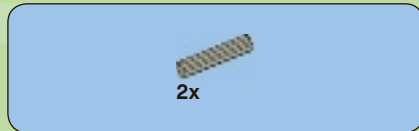

3

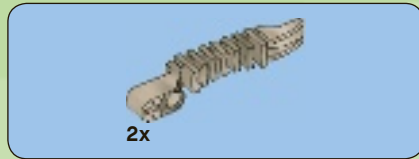
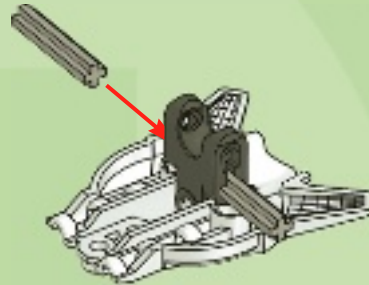

4

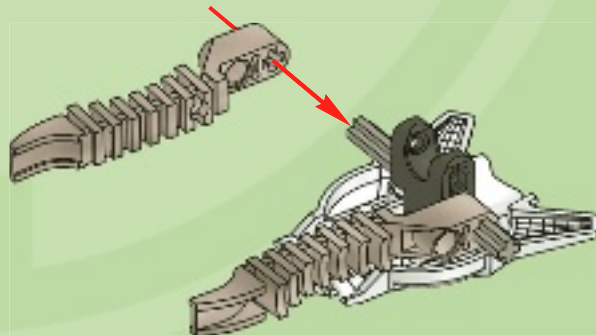



2x

5

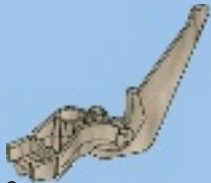
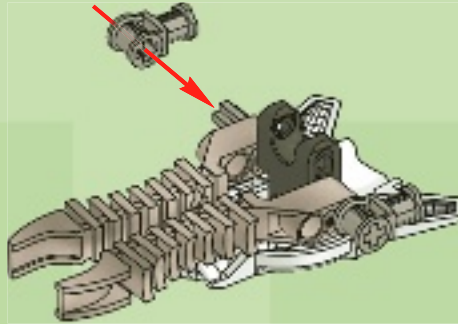

2x

6

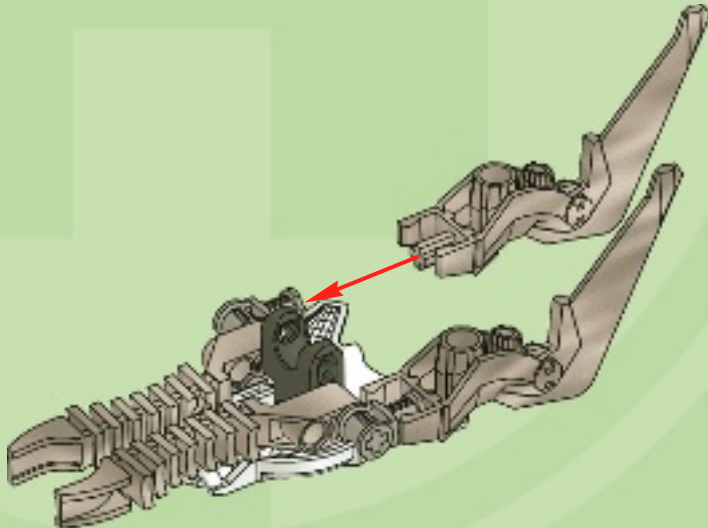

28

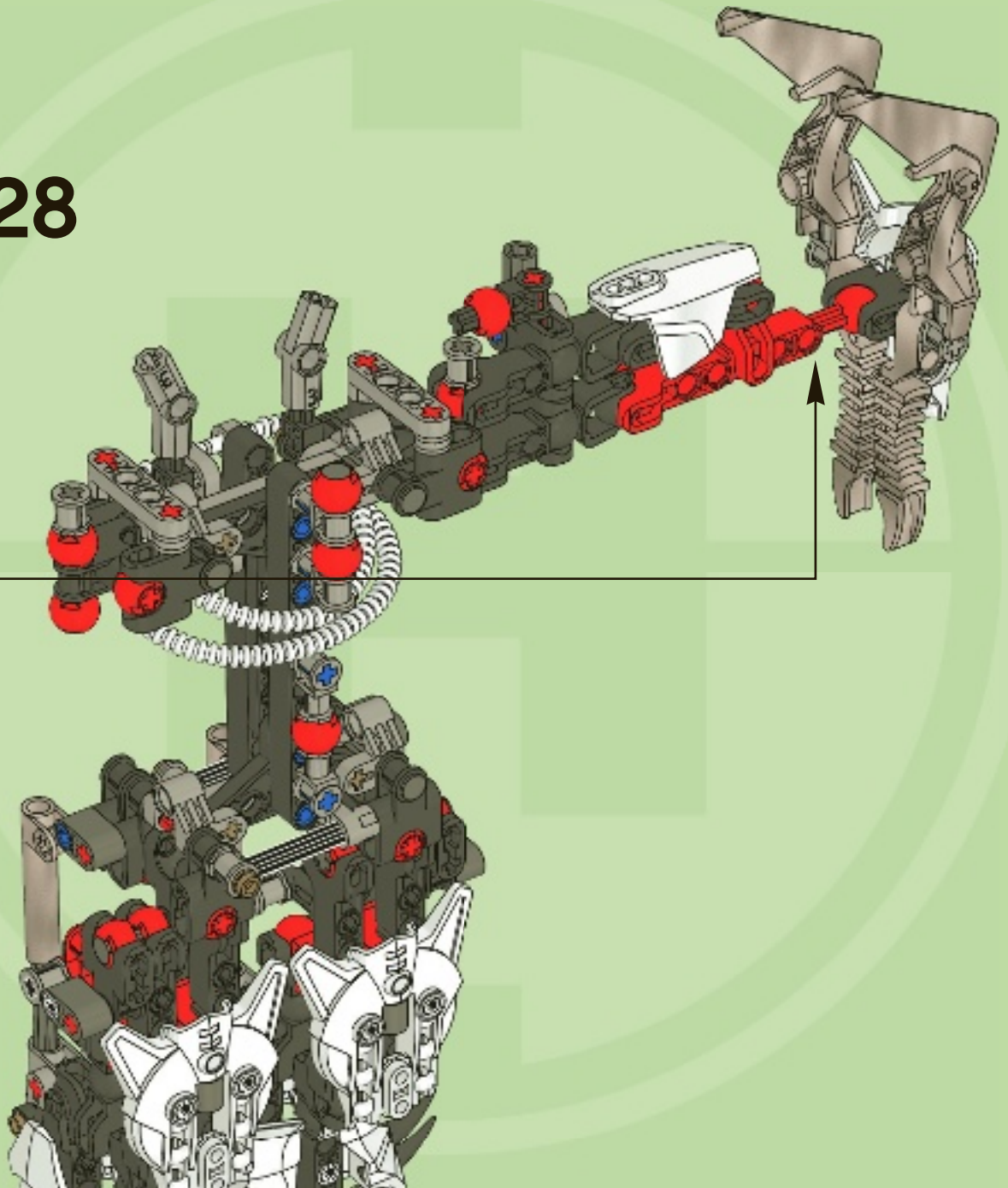

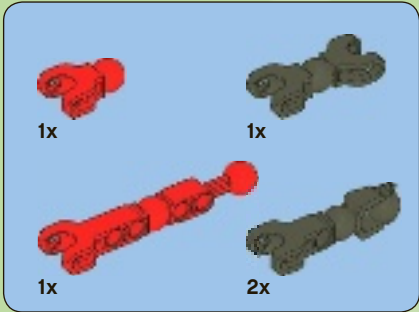
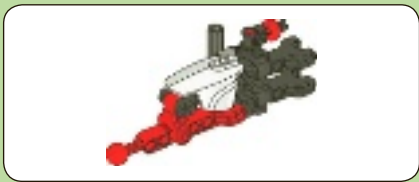

29

1

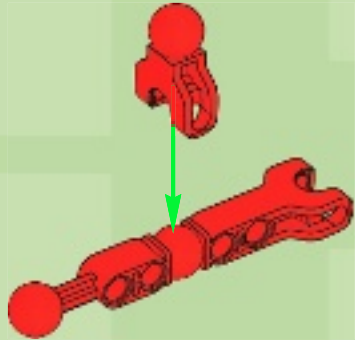

2

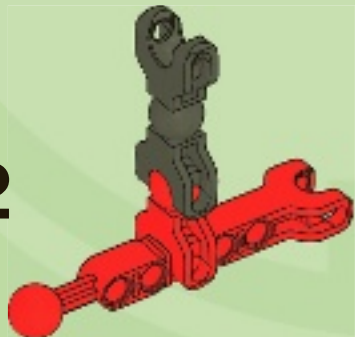

3

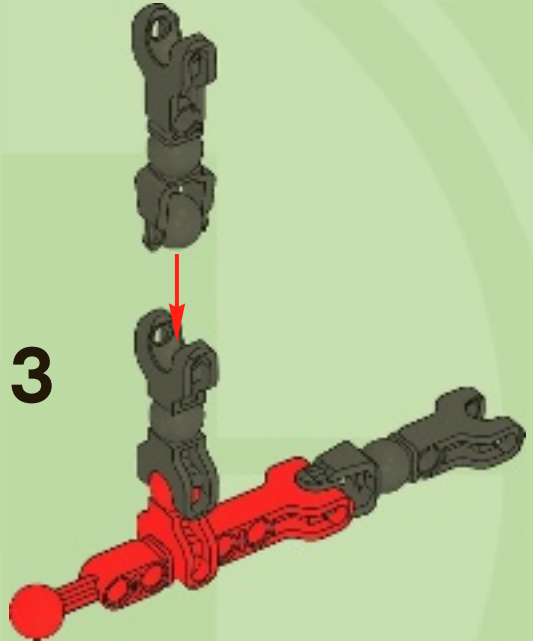

4

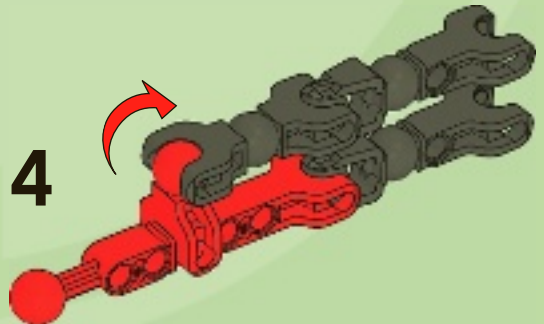

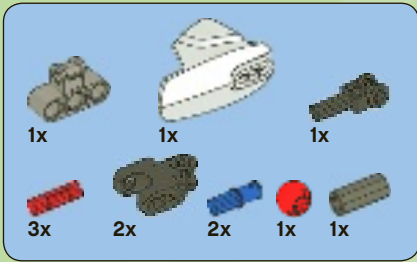

30

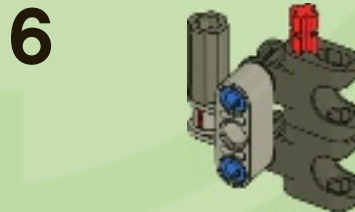
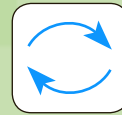
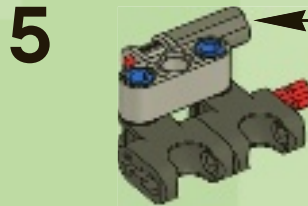
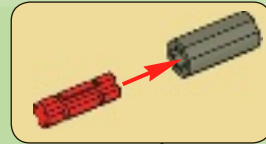
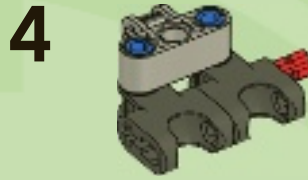
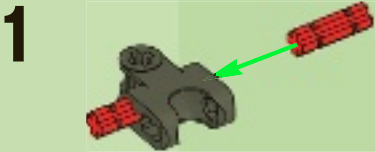

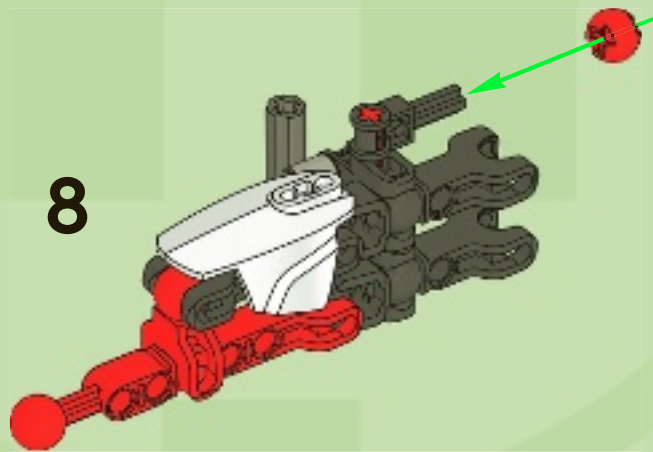
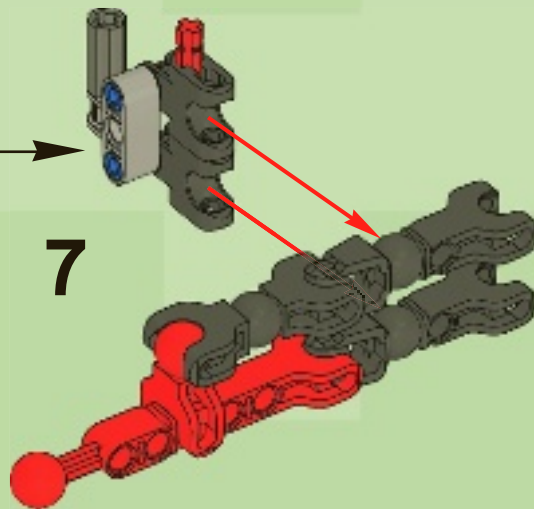

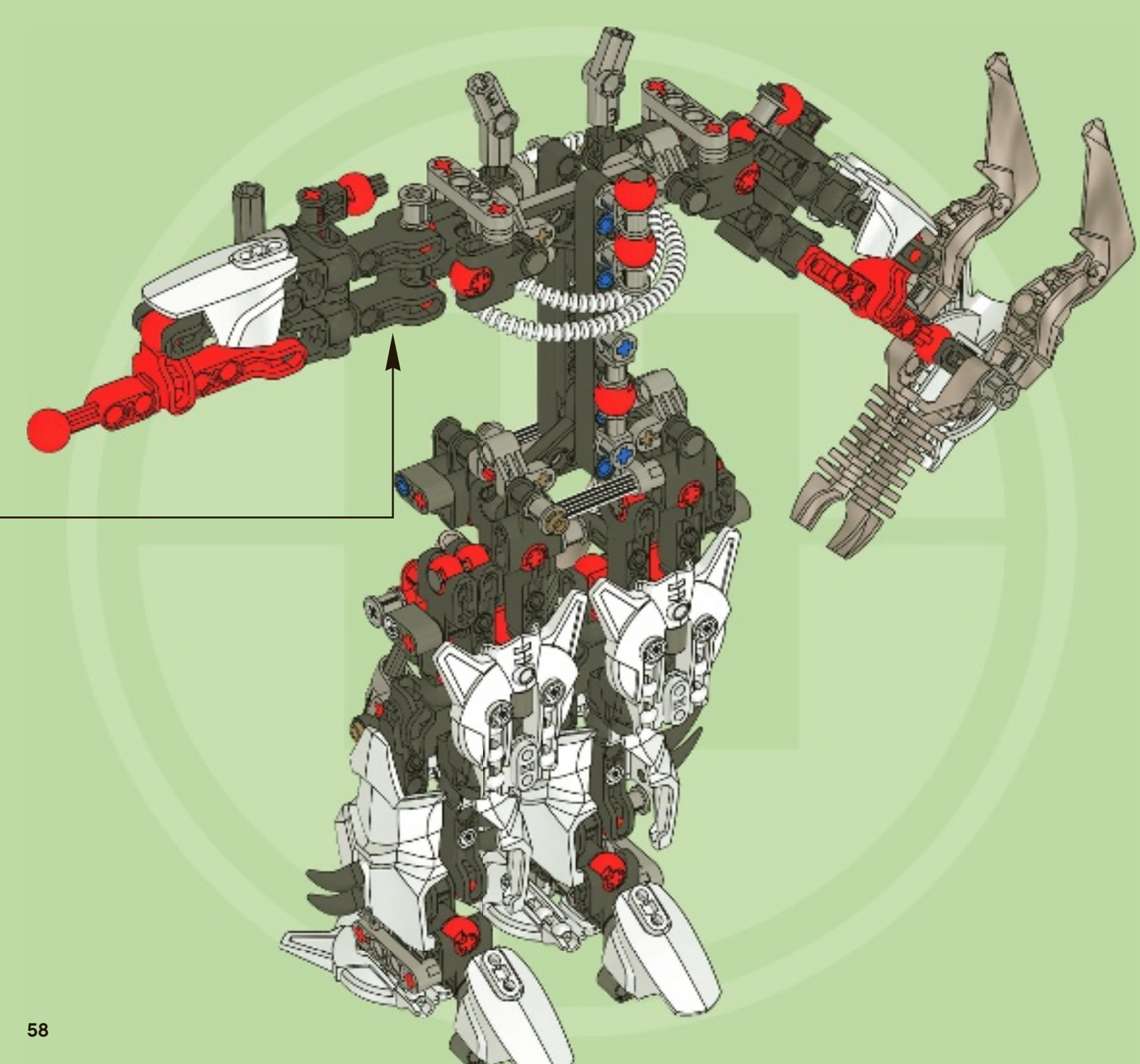

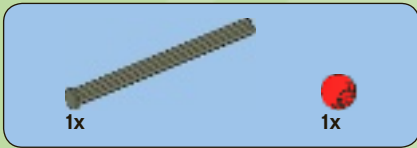

1

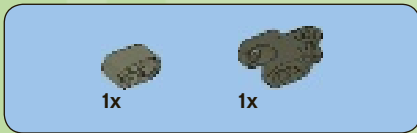
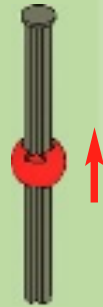

2

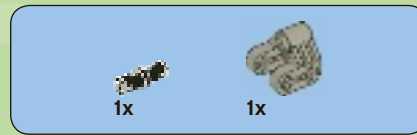

3

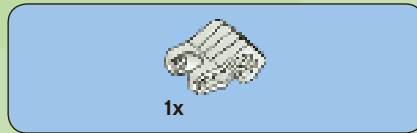

4





2x

5



2x

6



4x

7



1x



1x

8

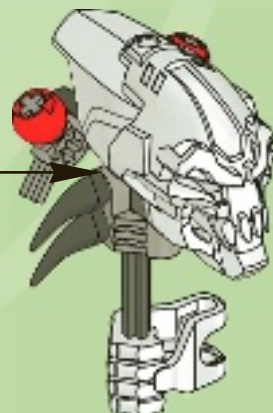
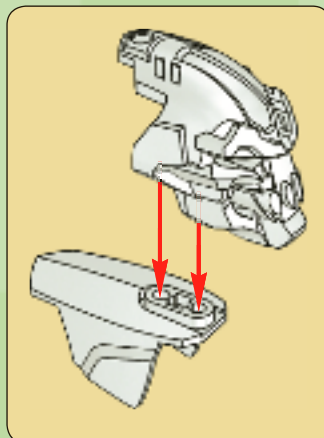

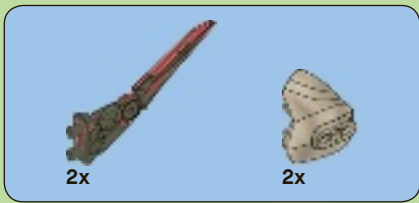

9

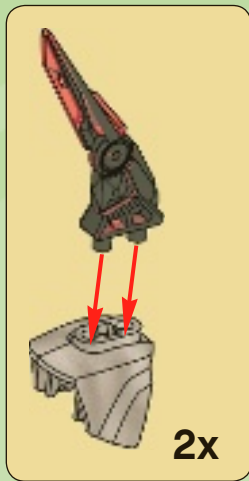

10

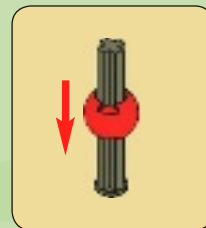

31

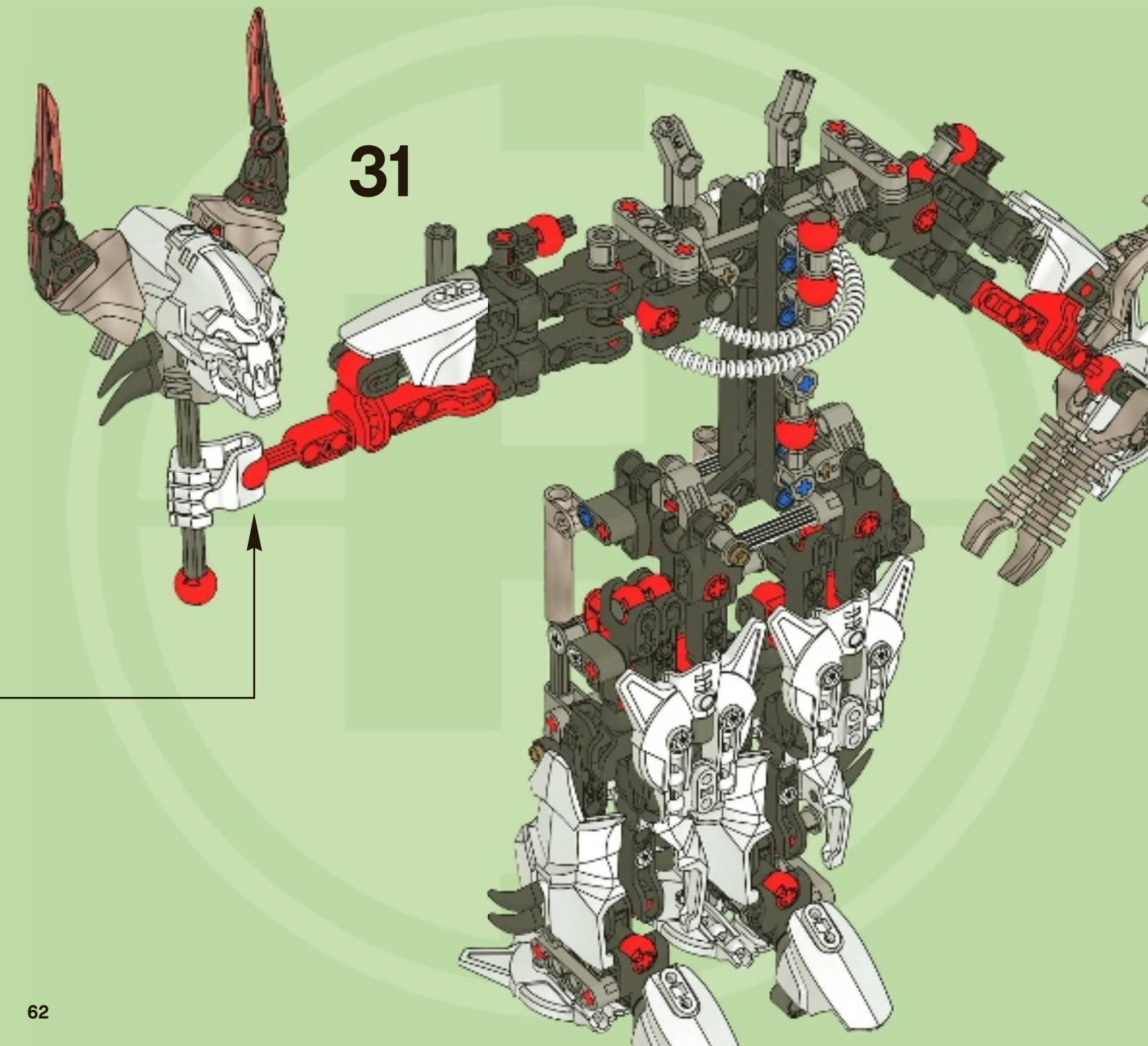

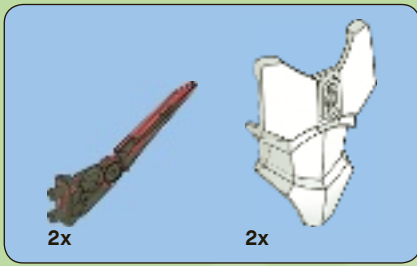

32

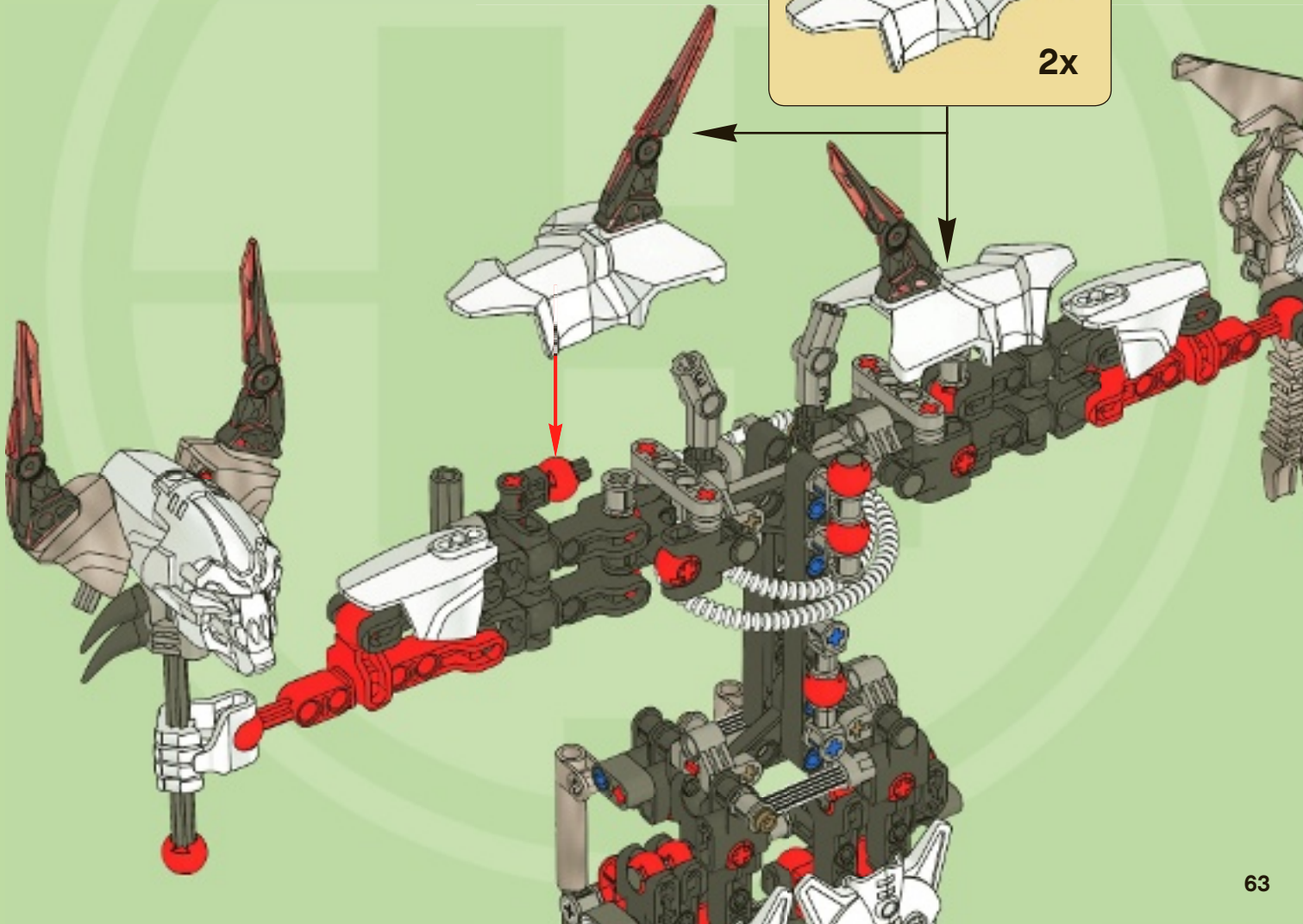

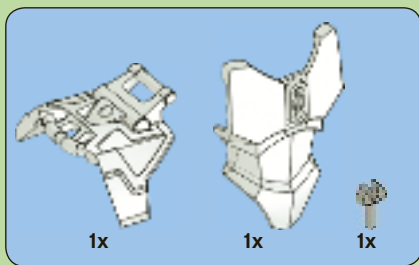

33

1

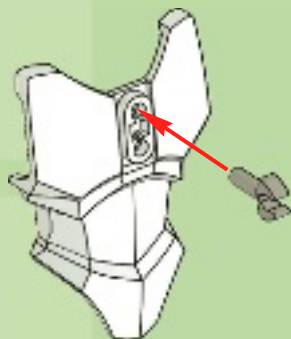

2

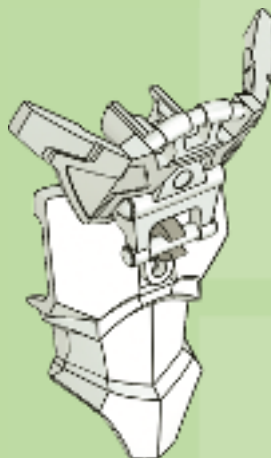

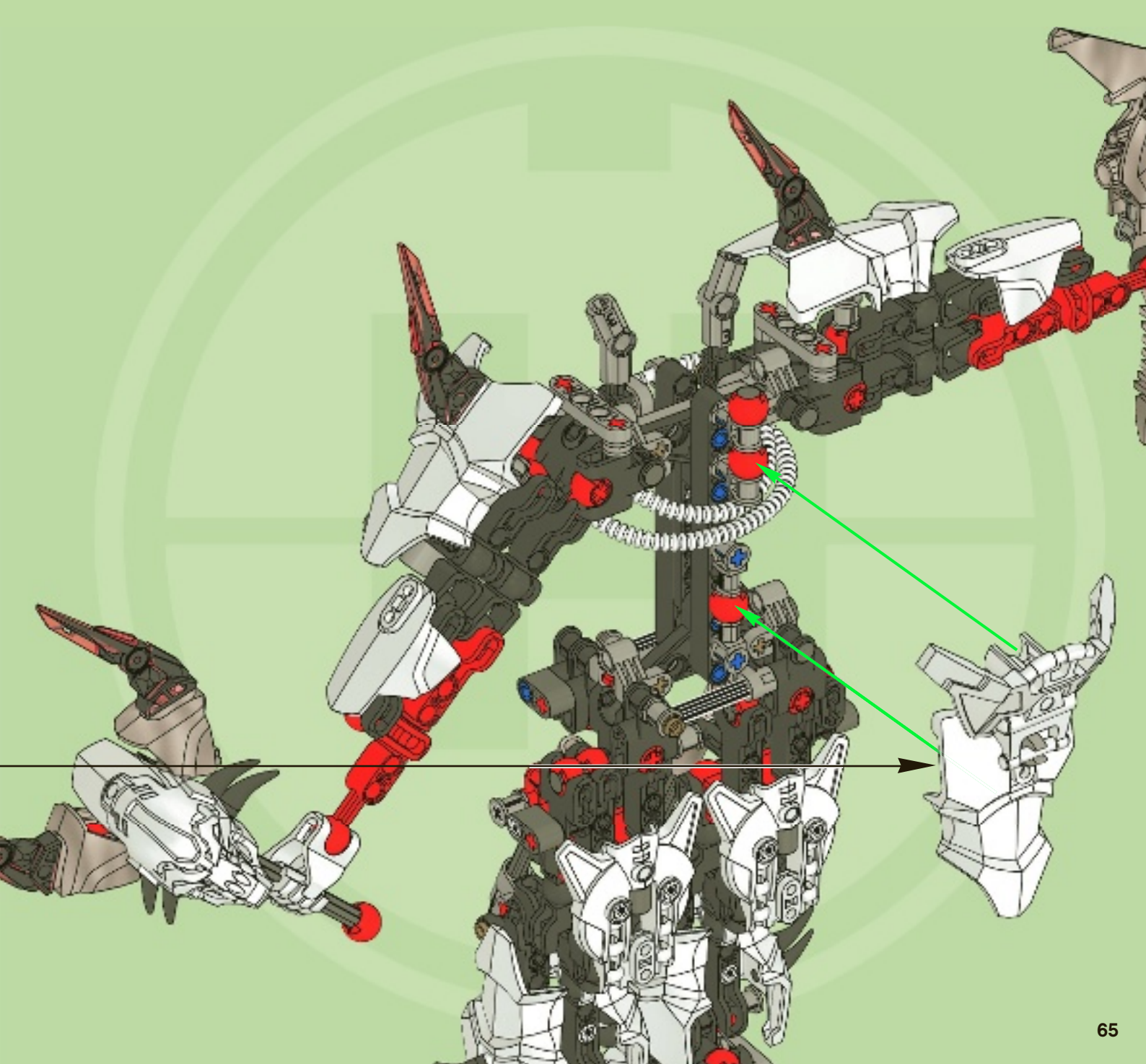



34

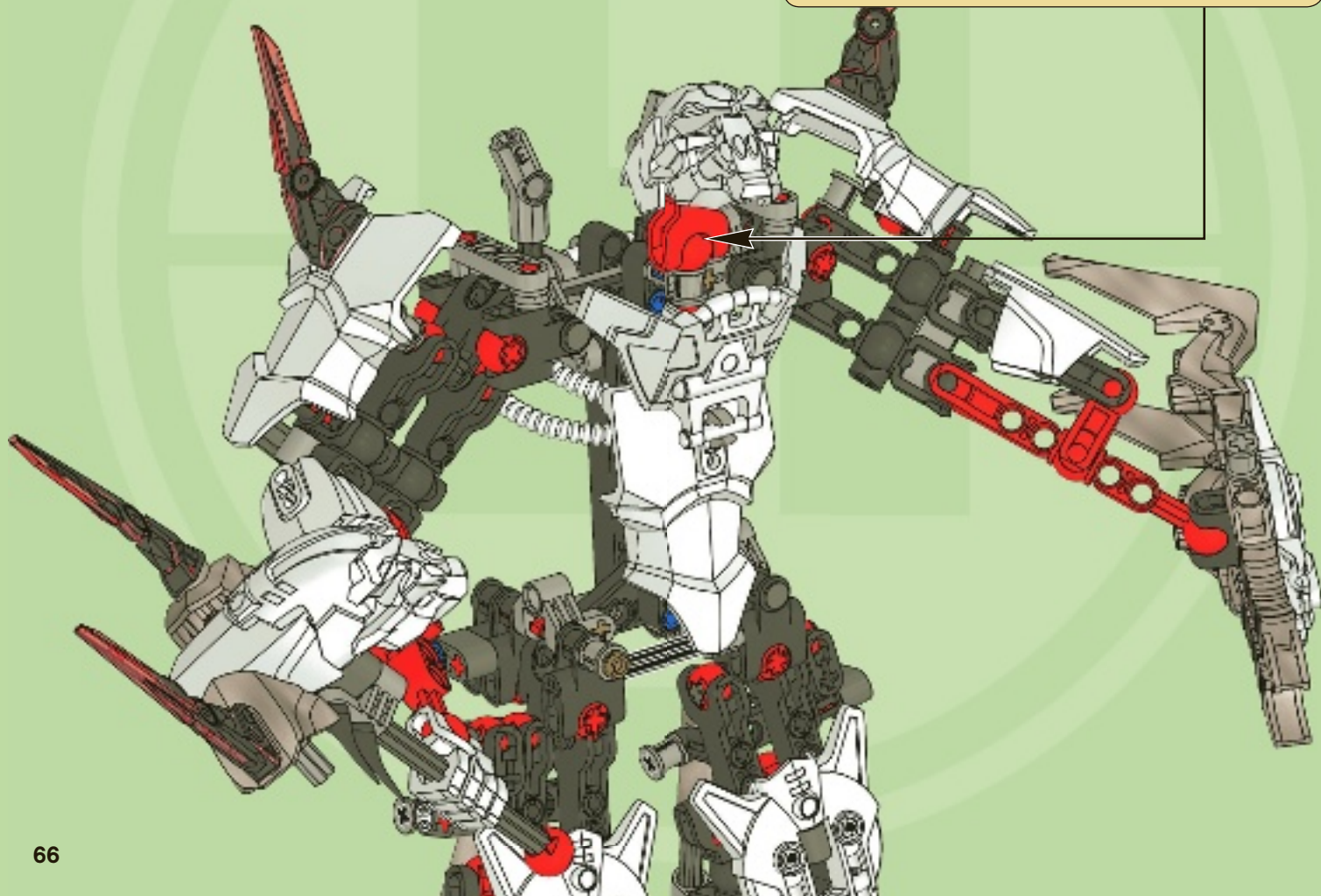
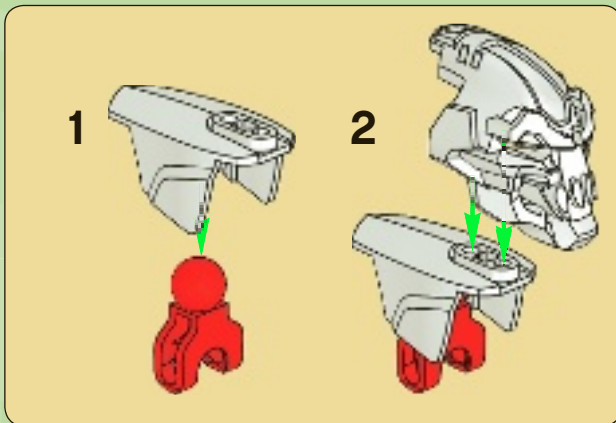

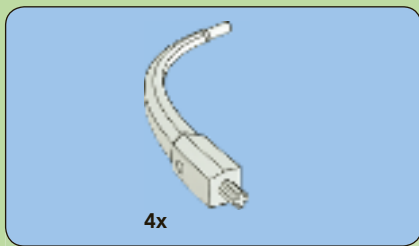

35

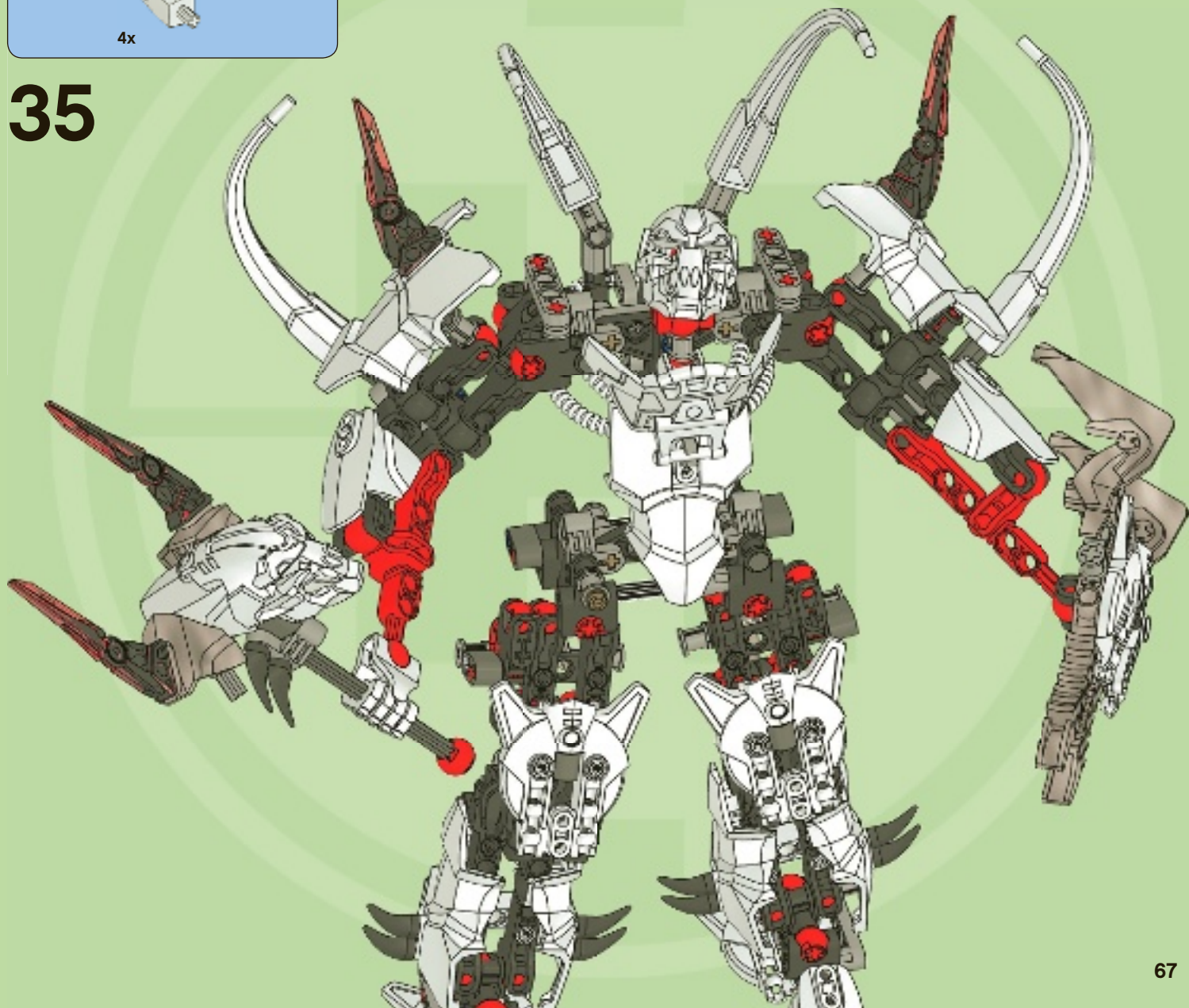



1x

36

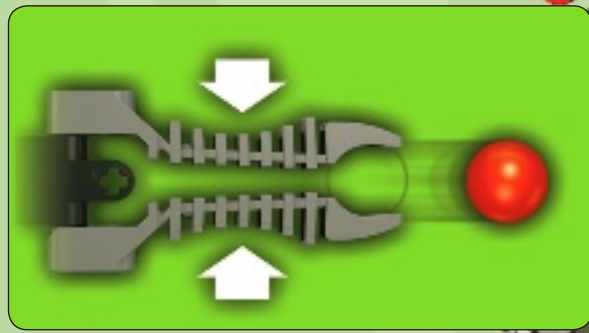
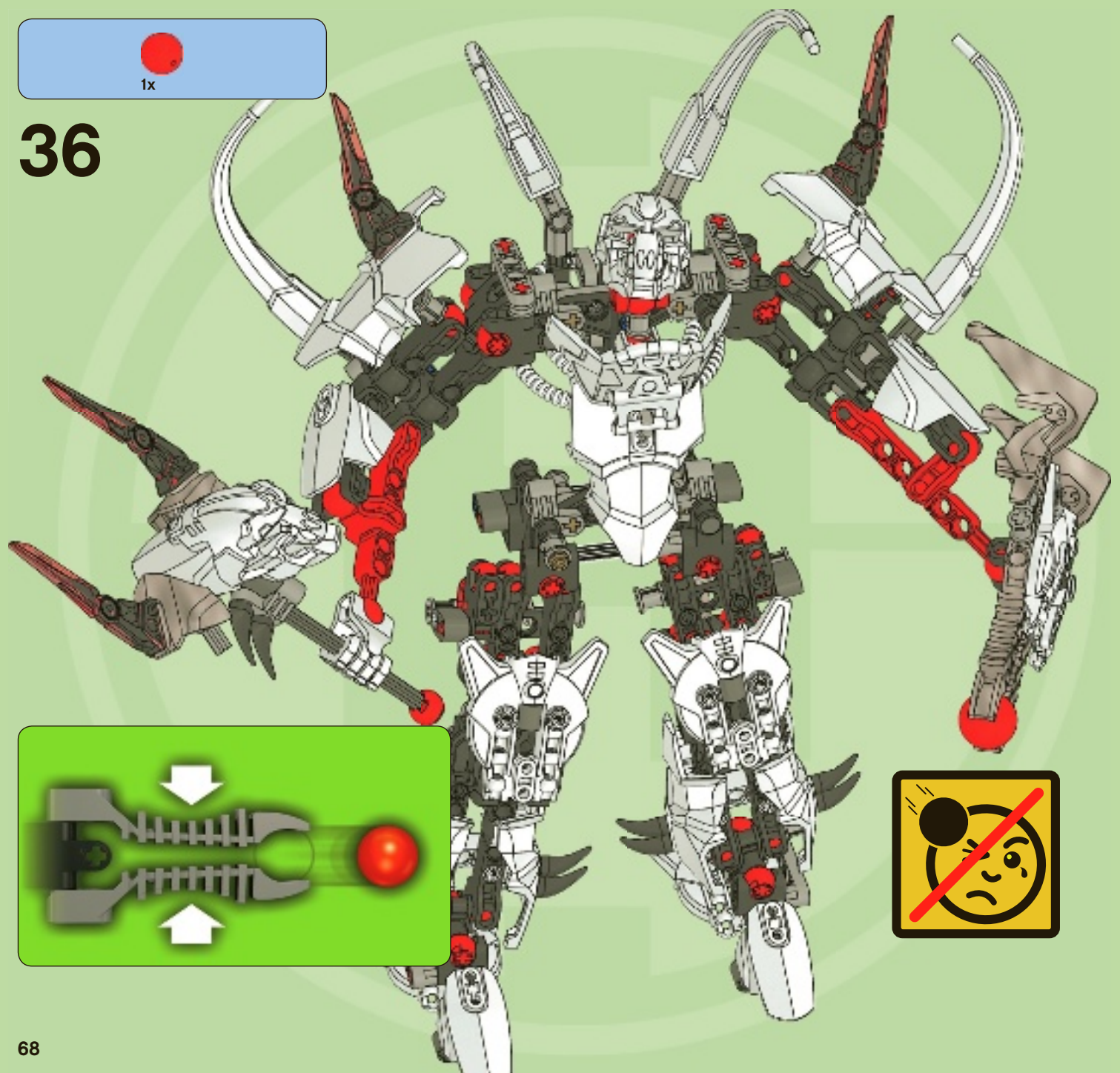

15x
4121715

4x
4107765

4x
4238840

28x
4610948

12x
4563477

5x
370626

4x
4630132

2x
4142543

1x
4114634

10x
4593567

4x
4593562

8x
4593558

2x
4156150

9x
4630114

2x
4538007

4x
4211741

5x
4211561

2x
4503416

5x
4211573

15x
4211622

2x
4211552

6x
4211553

2x
4502595

5x
4211815

1x
4542590

2x
4211775

9x
4515183

2x
4552349

2x
4516546

11x
4560177

5x
4499858

2x
4591620

2x
4609595

2x
4632610

2x
4609612

2x
4128594

39x
4615070

7x
4609813

33x
4142865

1x
4545430

2x
4591538

10x
4206482

4x
4514553

7x
4566927

2x
4208160

1x
4610918

2x
4591641

4x
4603309

5x
4614252

6x
4632643

7x
4632590

1x
4624060

2x
4610846



Customer Service
Kundenservice
Service Consommateurs
Servicio Al Consumidor

www.lego.com/service or dial

: 00800 5346 5555
: 1-800-422-5346

2236



2145



Now on DVD
Jetzt auf DVD
Maintenant en DVD
Ahora en DVD
Agora em DVD
Már kapható DVD-n



HEROFACTORY.LEGO.COM

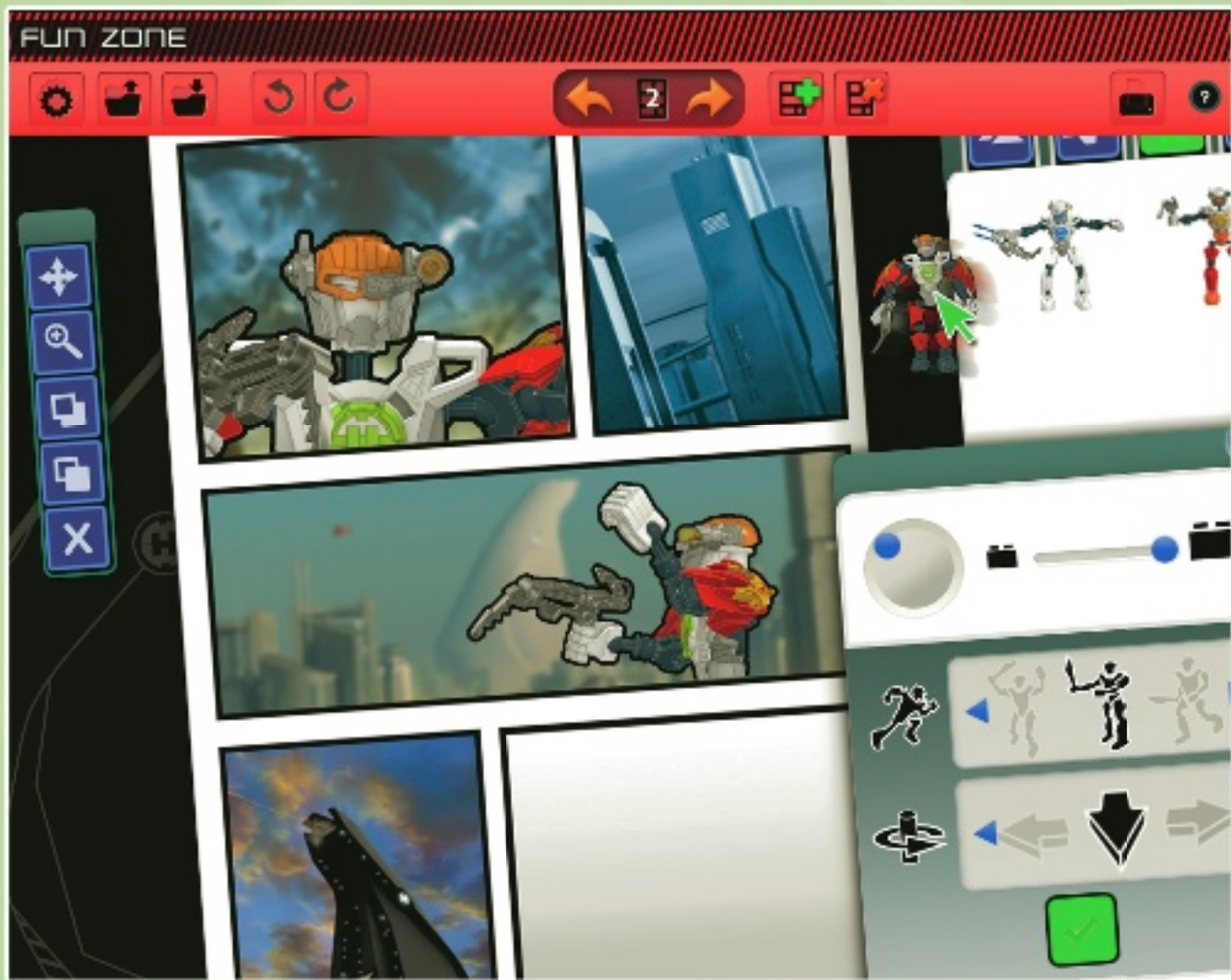

HEROFACORY.LEGO.COM



HERO
RECON
TEAM



herorecon.LEGO.com



DESIGN by ME



www.LEGOclub.com



LEGO® Club Email

LEGO club™

FREE! GRATIS! GRATUIT!



LEGO® Club Magazine

SIGN UP ONLINE!

www.LEGOclub.com



00800 5346 5555*



1-866-534-6258 • 1-877-518-5346

US & Canada only

Canada seulement

* Freephone. Mobile charges may apply.
* Numéro sans frais. Des frais peuvent s'appliquer avec les téléphones cellulaires.
* Gebührenfrei, Kosten für Anrufe aus Mobilfunknetzen können abweichen.
* Gratis telefonnummer vanaf vaste lijn.
* Det er et gratis nummer, når du ringer fra fasttelefon.
* Det är gratis, när du ringer från en fast telefon.
* Numéro sans frais. Des frais peuvent s'appliquer avec les téléphones portables.



WIN!

Go to www.LEGOsurvey.com/product to fill out a survey for a chance to win a cool LEGO® Product. No purchase necessary. Open to all residents where not prohibited.

 www.LEGO.com



www.LEGOsurvey.com/product

GEWINNE! WIN!

Nimm an der Umfrage auf www.LEGOsurvey.com/product teil und hab die Chance ein cooles LEGO® Produkt zu gewinnen!
Die Teilnahme am Gewinnspiel führt zu keinerlei Kaufverpflichtungen. Teilnahme in allen nicht ausgeschlossenen Ländern möglich.

Ga naar www.LEGOsurvey.com/product, vul een enquêteformulier in en maak kans op een cool LEGO® product.
Geen aankoopverplichting. Iedereen mag deelnemen, uitzonderend ingezetenden van landen waar een enquêteverbod geldt.

GAGNE! 当てよう!

Visite www.LEGOsurvey.com/product pour répondre à un questionnaire et avoir une chance de gagner un produit LEGO® très cool!
Aucune obligation d'achat. Ouvert à tous les résidents des pays autorisés.

www.LEGOsurvey.com/product にアクセスして、アンケートにご記入ください。当選者にはレゴ®製品を差し上げます。
お買い上げの必要はありません。
禁止されていない限り、すべての皆様にご利用いただけます。