

**LEGO**

**GH**OST**BUSTERS**



**BUILDING INSTRUCTIONS**

# WHO YOU GONNA CALL?

In the early 1980s an inspired film concept was born — unleash an ultimate supernatural power on the city of New York and call upon the best comedic talent in Hollywood to save the day. Then, throw in great special effects and a talented director. Next comes the blockbuster film that audiences have loved for thirty years *Ghostbusters!*



When strange paranormal incidents began occurring at Columbia University, the Paranormal Studies Department began to investigate. Despite their findings, Dr. Peter Venkman, Dr. Ray Stantz, and Dr. Egon Spengler lost their funding and were thrown out. They regrouped and formed a paranormal detection and elimination service called *Ghostbusters*. Ray purchased an old ambulance that was transformed into their ghost-busting vehicle, the *Ecto-1*. Their first assignment called on them to remove Slimer, a gluttonous apparition from the Sedgwick Hotel. After successfully completing the job, the team continued their work and their business grew, so they hired another team member, Winston Zeddemore.



All four of them were put to the ultimate test when they had to save New York from Zuul, a paranormal powerhouse. Just when their battle seemed lost, the Ghostbusters made a daring decision to cross the particle streams from their proton packs which resulted in a catastrophic explosion that incinerated the giant

Mr. Stay Puft Marshmallow man and destroyed Zuul. Luckily the team survived the blast and the Ghostbusters received praise for saving the city.



*"If there's a steady paycheck in it,  
I'll believe anything you say."*



*"Back off, man, I'm a scientist."*



*"Listen! Do you smell something?"*



*"I collect spores, molds,  
and fungus."*

# MADE FOR GHOSTBUSTERS

The *Ecto-1* was a 1959 professional ambulance converted into the famous *Ecto-1* for the 1984 *Ghostbusters* film. The original design of the *Ecto-1* was an all-black vehicle with flashing purple and white strobe lights. The ghost-busting machine resembled a hearse instead of an ambulance. During production, the filmmakers realized the majority of the scenes took place at night so a dark car would be lost onscreen. For better visibility on the dark streets of New York, they decided the *Ectomobile* should be all white with red trim. The original script for *Ghostbusters* was more

of a fantasy film set in the future so the *Ectomobile* could dematerialize among other things. When the film was set in reality, the fantasy functions of the car were eliminated, and the humor was derived from a team riding in a beat-up old ambulance that barely ran. Today, the *Ecto-1* remains one of the most iconic movie cars of all time.

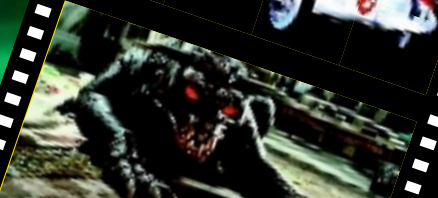



**GH**o**STBUSTERS.**

# QUI C'EST QU'ON APPELLE ?

Au début des années 1980, un concept de film passionnant fut créé : lâchez une puissance surnaturelle sur la ville de New York et appelez les plus grands talents comiques d'Hollywood pour sauver la situation. Ajoutez ensuite quelques effets spéciaux géniaux et un réalisateur de talent. Vous obtenez ainsi un film à succès que le public adore depuis 30 ans : *SOS Fantômes* !

Lorsque d'étranges incidents paranormaux commencèrent à se produire à l'Université de Columbia, le département des Études paranormales lança une enquête. Malgré leurs découvertes, les professeurs Peter Venkman, Ray Stantz et Egon Spengler perdirent leur financement et furent renvoyés. Ils se regroupèrent et formèrent un service de détection et d'élimination paranormale appelé *SOS Fantômes*. Ray acheta une vieille ambulance qui fut transformée en véhicule de destruction de fantôme, l'*Ecto-1*. Leur première mission fut de supprimer Slimer, une apparition gluante dans l'Hôtel Sedgwick. Après le succès de leur intervention, l'équipe continua à travailler et leurs activités se développèrent. Ils engagèrent donc un nouveau membre dans l'équipe, Winston Zeddemore.

Les quatre collaborateurs furent soumis à une épreuve suprême lorsqu'ils durent protéger New York contre Zuul, une puissance paranormale. Alors que leur combat semblait perdu, les chasseurs de fantômes prirent la décision intrépide de croiser les rayons de particules de leurs packs de protons, ce qui produisit une explosion

catastrophique qui incinéra le Bibendum chamallow et détruisit Zuul. L'équipe survécut heureusement à l'explosion et les chasseurs de fantômes furent félicités pour avoir sauvé la ville.



«Hum, contre un chèque avec beaucoup de zéros je peux croire tout ce que vous dites.»



«Toi, tu t'tires. C'est moi l'chercheur.»



«Écoutez ! Vous sentez quelque chose ?»



«Je collectionne spores, moisissures et amanites.»

# CRÉE POUR SOS FANTÔMES

L'*Ecto-1* était une ambulance professionnelle de 1959 transformée en *Ecto-1* pour le film *SOS Fantômes* de 1984. Le design original de l'*Ecto-1* était un véhicule tout noir avec des lumières stroboscopiques violettes et blanches. La machine à détruire les fantômes ressemblait à un corbillard plutôt qu'à une ambulance. Pendant la production, les réalisateurs du film se rendirent compte que la plupart des scènes se passaient la nuit et que par conséquent un véhicule sombre ne se verrait pas bien à l'écran. Pour obtenir une meilleure visibilité dans les rues sombres de New York, ils décidèrent donc que l'*Ectomobile* devait être toute blanche avec une ligne rouge. Selon le scénario original, *SOS Fantômes* était un film fantastique

se déroulant dans le futur, afin que l'*Ectomobile* puisse entre autres se dématérialiser. Lorsque le film est passé à la réalité, les fonctions fantastiques de la voiture ont été éliminées et l'effet comique naissait de voir l'équipe se déplacer dans une vieille ambulance qui fonctionnait à peine. L'*Ecto-1* reste aujourd'hui l'une des voitures les plus célèbres de l'histoire du cinéma.

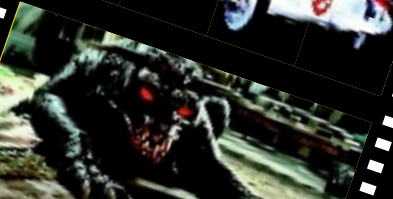





**GH**ST**BUSTERS**

# ¿A QUIÉN VAS A LLAMAR?

A principios de la década de 1980 nació un nuevo concepto cinematográfico que desató un terrorífico poder sobrenatural sobre la ciudad de Nueva York y puso de su lado a los mejores actores cómicos de Hollywood. El talento del director y unos asombrosos efectos especiales dieron como resultado un gran éxito que el público no ha olvidado en treinta años: ¡Cazafantasmas!



Quando unos extraños sucesos paranormales comienzan a ocurrir en la Universidad de Columbia, el Departamento de Estudios Paranormales comienza a investigar. A pesar de sus hallazgos, los doctores Peter Venkman, Ray Stantz y Egon Spengler pierden sus fondos y son expulsados, tras lo que deciden reagruparse y fundar un servicio de detección y eliminación paranormal llamado *Cazafantasmas*. Ray compra una vieja ambulancia que se convierte en el transporte del grupo: el *Ecto-1*. Su primera misión es acabar con Pegajoso, un glotón fantasma que se aparece en el hotel Sedgewick. El negocio crece como resultado de su éxito, por lo que el equipo decide contratar un nuevo miembro: Winston Zeddemore.

Los cuatro se ponen a prueba cuando deben salvar Nueva York de Zuul, una fuente de energía paranormal. Cuando su batalla parece perdida, los *Cazafantasmas* toman la arriesgada decisión de cruzar los flujos de partículas de sus mochilas de protones para generar una catastrófica explosión que incinera al Hombre de

Malvisco y destruye a Zuul. Por suerte, el equipo sobrevive al estallido y los *Cazafantasmas* son aclamados por salvar la ciudad.



«Si pagan bien, creeré en todo»



«No se meta, soy un científico»



«¡Escuchen! ¿Huelen algo?»



«Colecciono esporas, musgos y hongos»

# SÓLO PARA CAZAFANTASMAS

El *Ecto-1* era una ambulancia profesional de 1959 que se convirtió en el famoso auto de los *Cazafantasmas* para el éxito de 1984. Originalmente, el *Ecto-1* era un vehículo negro con luces giratorias e intermitentes moradas y blancas. El objetivo era que se viese más como un auto fúnebre que como una ambulancia. Durante la producción, los responsables se dieron cuenta de que la mayoría de las escenas tenía lugar durante la noche, así que un auto oscuro se perdería en la pantalla. Para que fuese más fácil ver al *Ectomóvil* en las oscuras calles de Nueva York, decidieron que debía ser todo blanco, con una franja roja. El guion original de los *Cazafantasmas* era más una fantasía futurista en la que el *Ectomóvil* podía desmaterializarse,

entre otras cosas. Cuando se optó por situar la película en la actualidad, las funciones fantásticas del auto se eliminaron, y se aprovechó la simpatía que desprendía el hecho de que el equipo viajase en una antigua ambulancia que apenas podía correr. Hoy, el *Ecto-1* sigue siendo uno de los autos cinematográficos más populares de todos los tiempos.

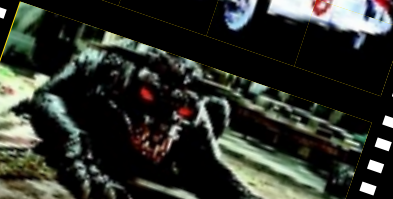



**GH**OS**TBUSTERS**



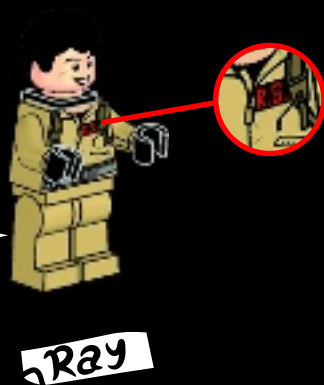

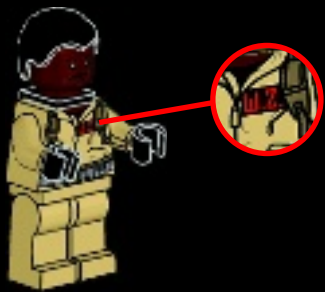

Winston

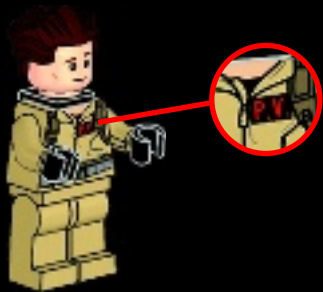

PETER



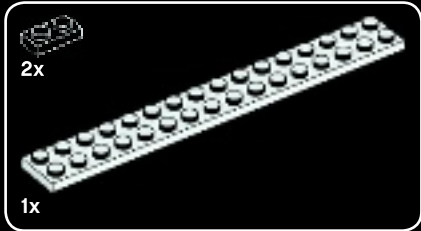

1

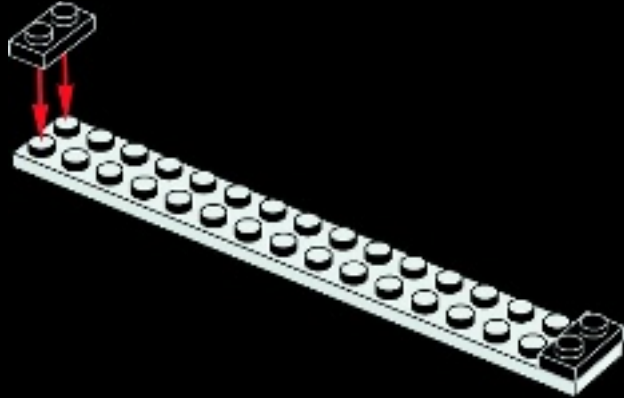

"Somebody blows their nose and you want to keep it?"

«C'est plus fort que toi hein dès qu'un mec se mouche faut que tu gardes la morve?»

«¿Alguien se sopla la nariz aquí y tu quieres guardarlo?»

VENKMAN





1x



6x



6x

# 2

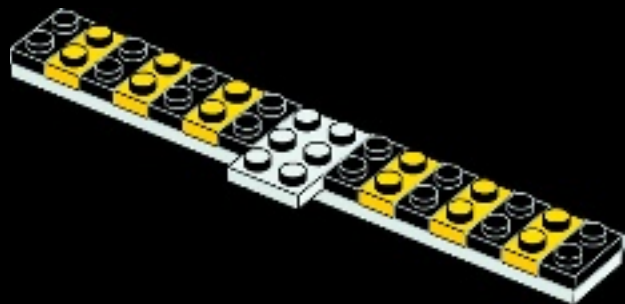

2x



8x



3x

# 3

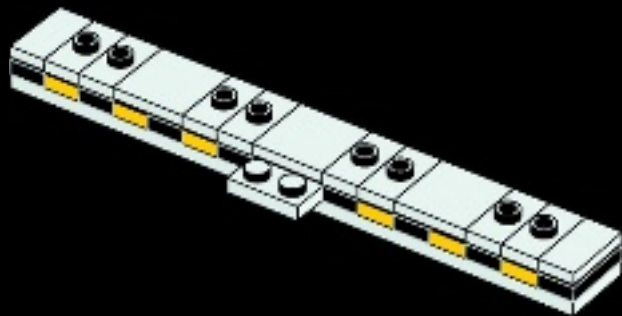



2x



1x

4

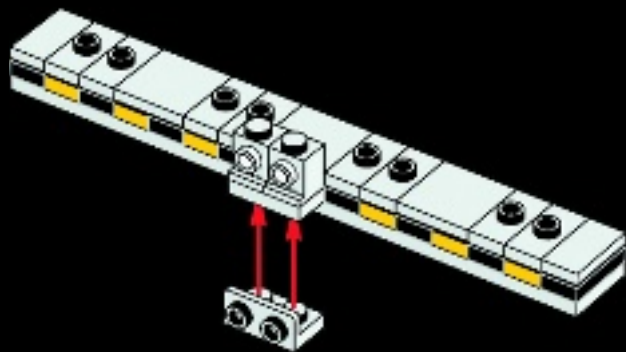

1x

5

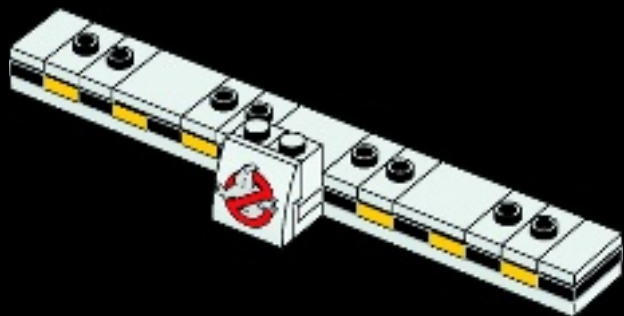

6

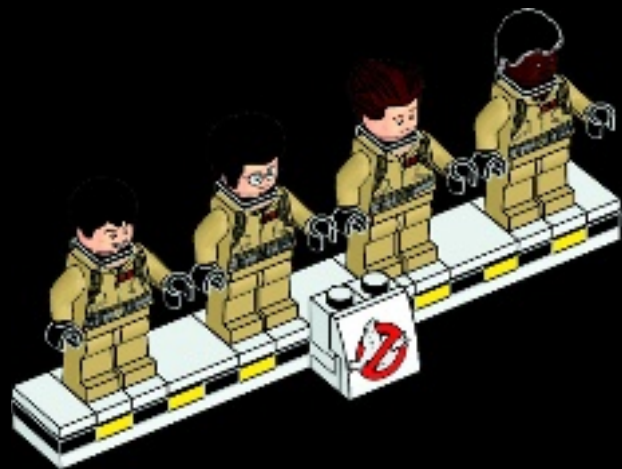



4x



2x

1

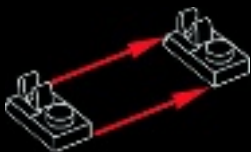

1x

2



SPENGLER

"I collect spores, molds, and fungus"

«Je collectionne spores, moisissures et amanites.»

«Colecciono esporas, musgos y hongos».

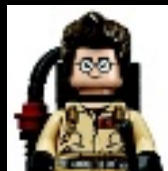

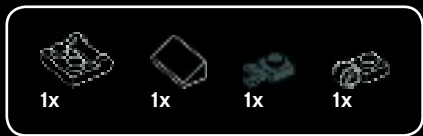

3

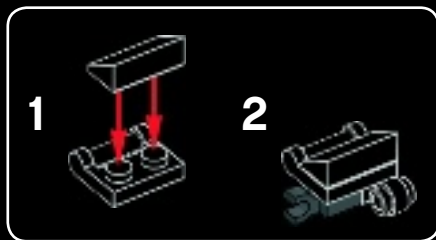



1x

4



1x

5





6

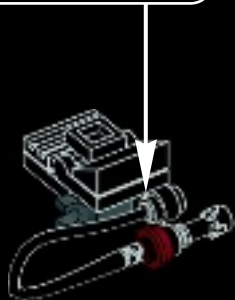
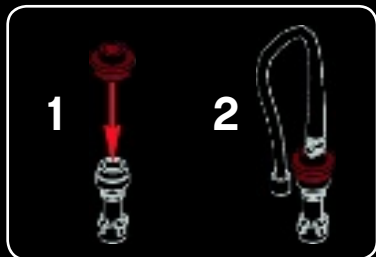

7



4x



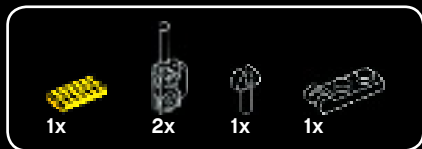

8

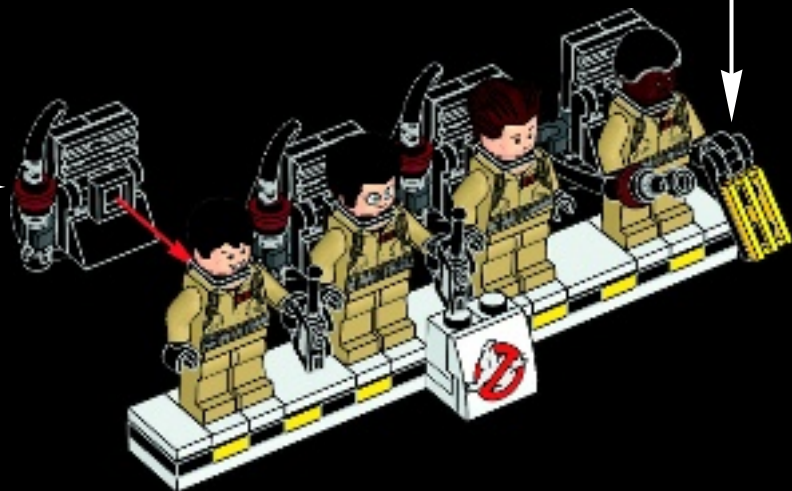
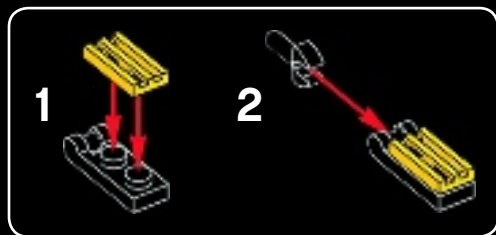

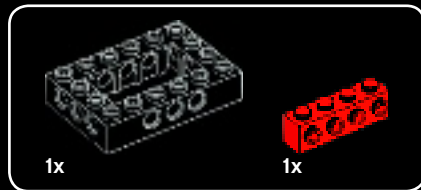
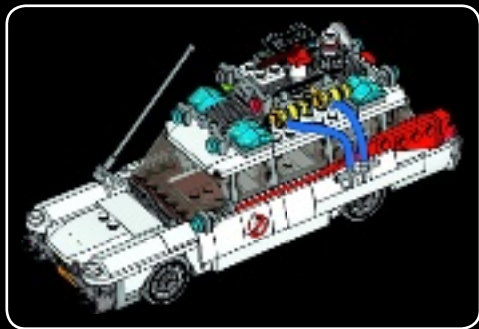

2

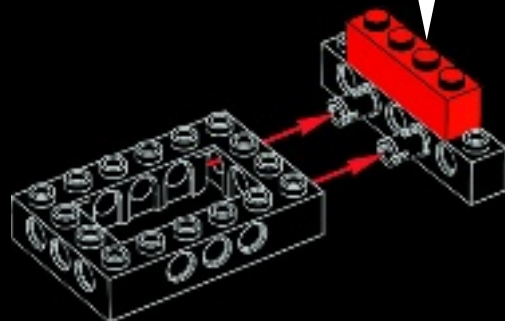



4x

3

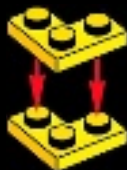

2x

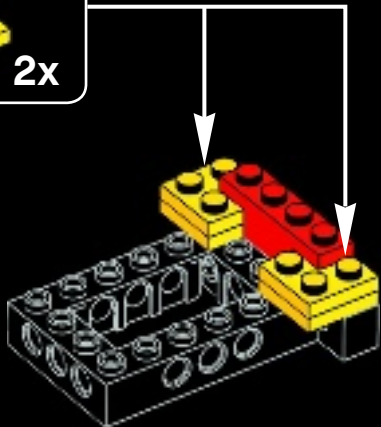

VENKMAN

"Twenty-four hours a day, seven days a week,  
no job is too big, no fee is too big!"

«Vingt-quatre heures sur vingt-quatre, sept  
jours sur sept, nous sommes des champions,  
nos prix sont champions!»

«Veinticuatro horas, siete días de la semana.  
Trabajos difíciles, precios bajos».

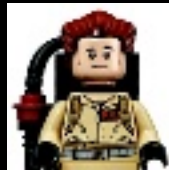

2x

4

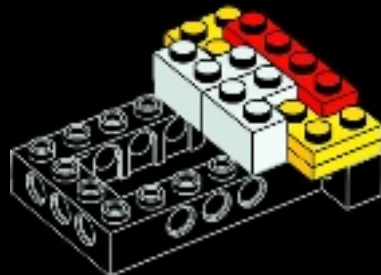



5

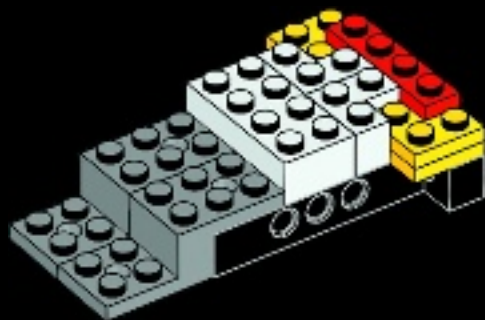

6

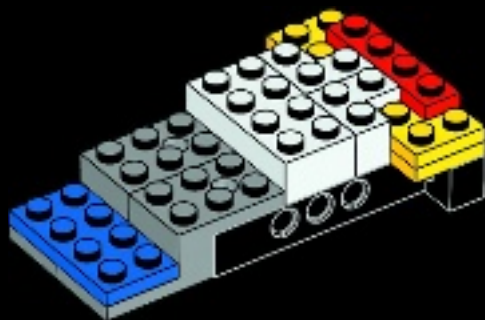

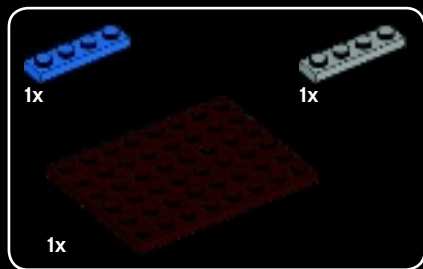

7

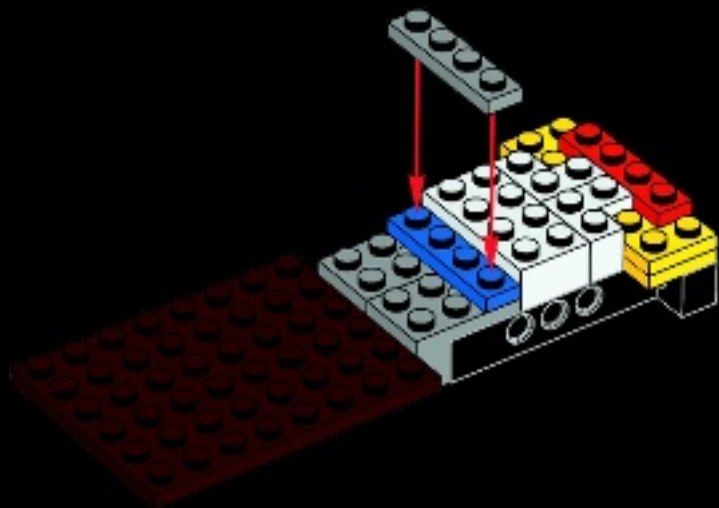

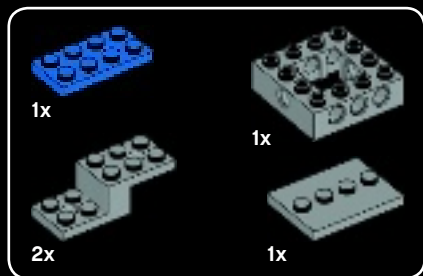

8

1



2



3

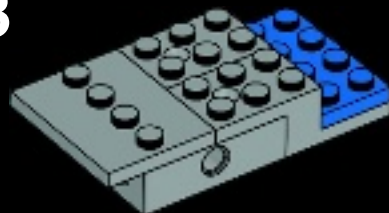

STANTZ

"Are you troubled by strange noises in the middle of the night?"

«Êtes-vous dérangé par des bruits étranges au milieu de la nuit?»

«¿Lo preocupan extraños sonidos en medio de la noche?»

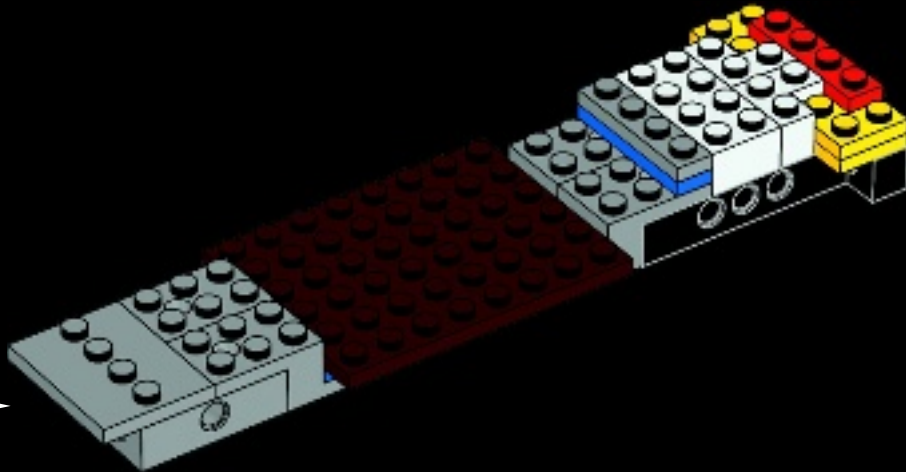

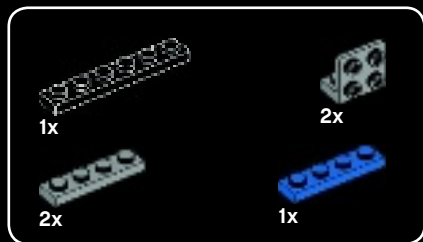

9

1

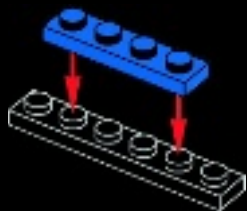

2

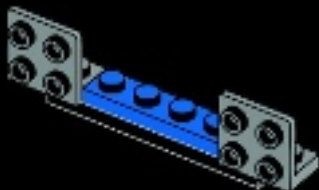

3

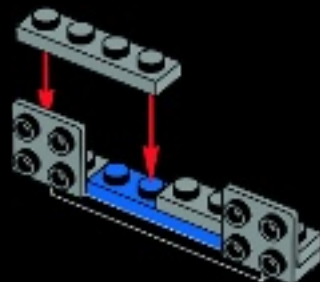



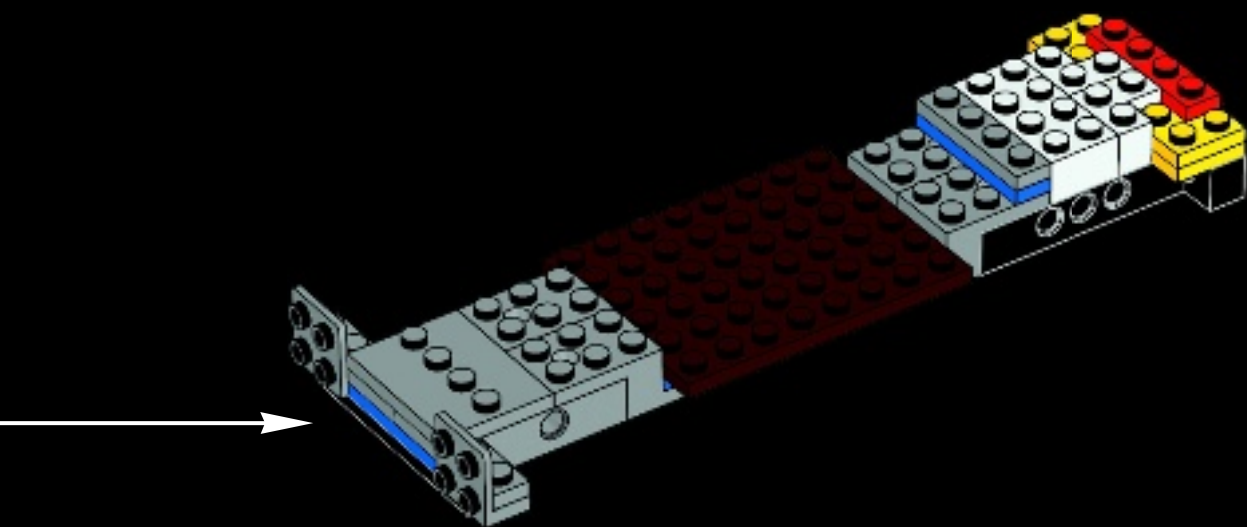



2x



2x

# 10

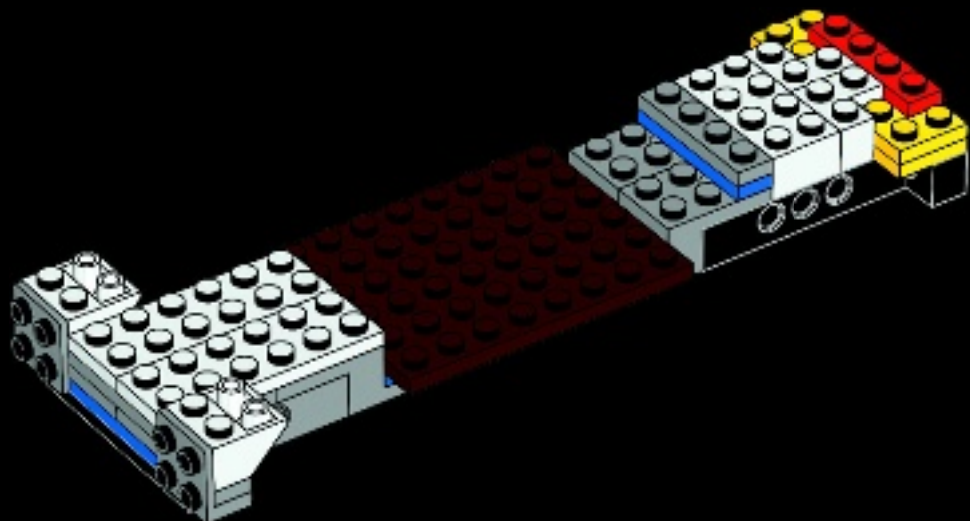



2x



1x

# 11

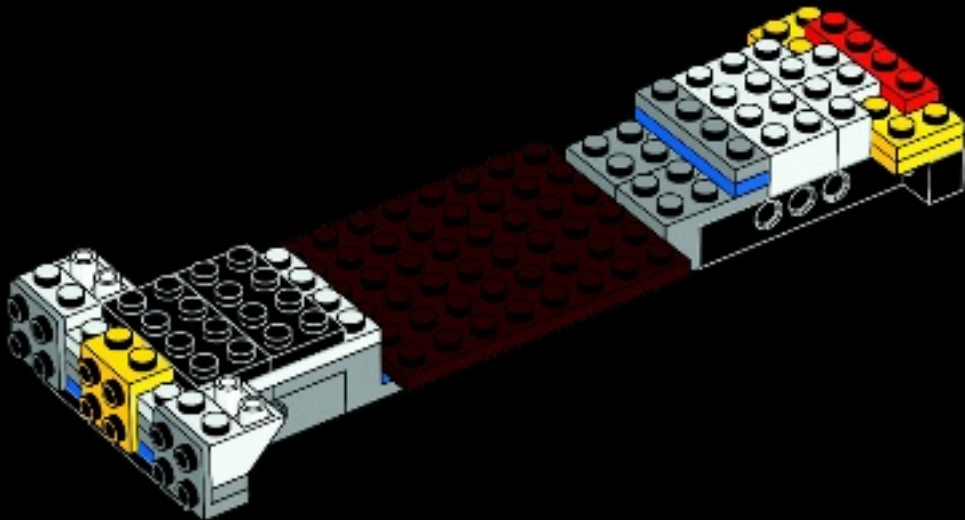

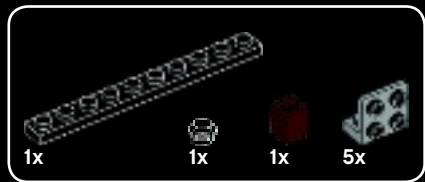

12

1



2

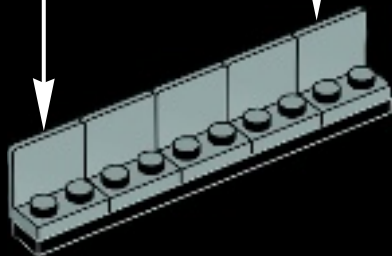

3

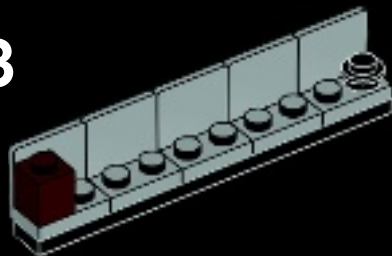

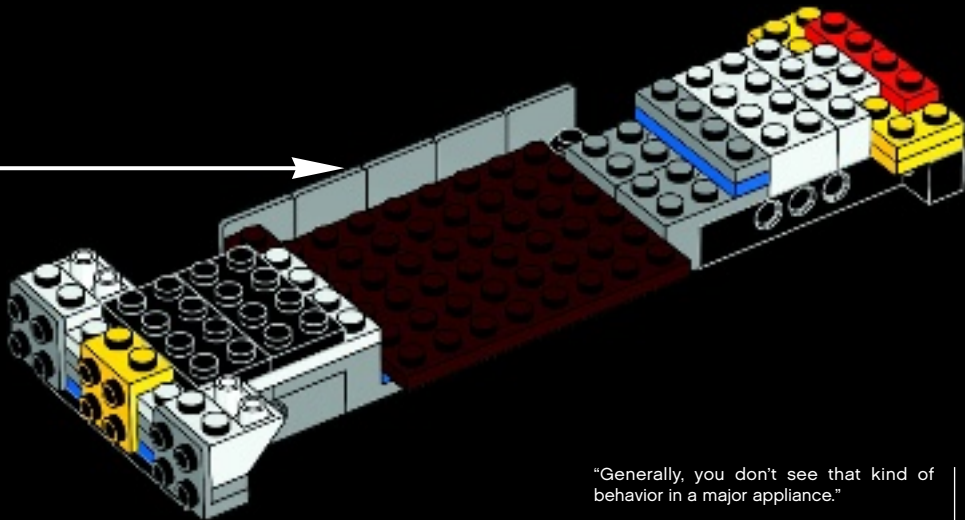

## VENKMAN

“Generally, you don’t see that kind of behavior in a major appliance.”

«C’est assez rare de voir ce type de comportement dans les grandes marques de l’électroménager.»

«Generalmente los artefactos no tienen ese comportamiento.»



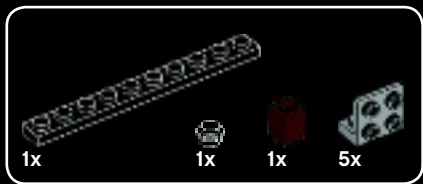

13

1



2

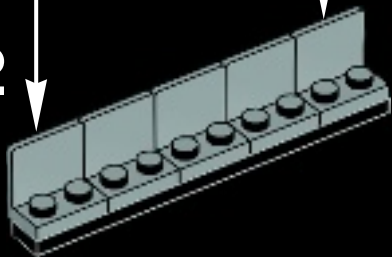

3

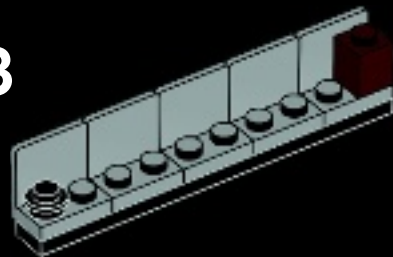

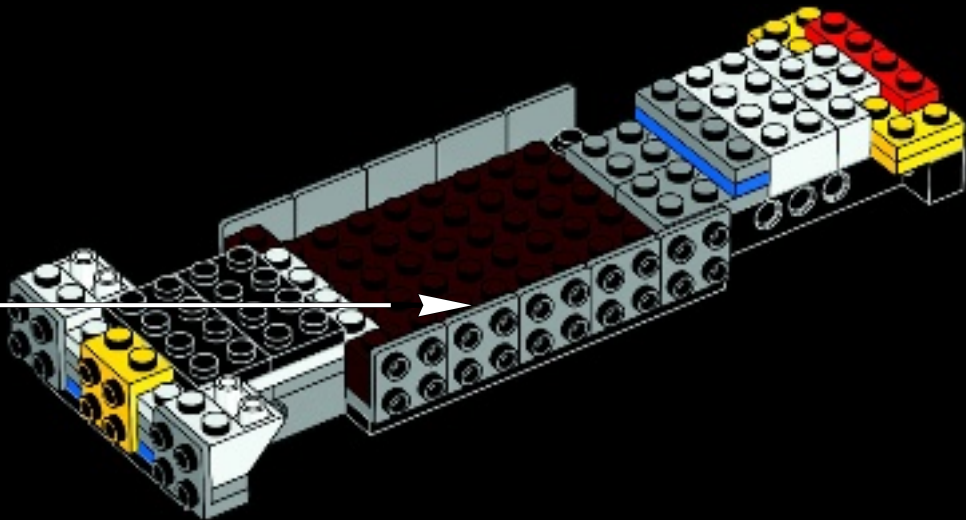



14

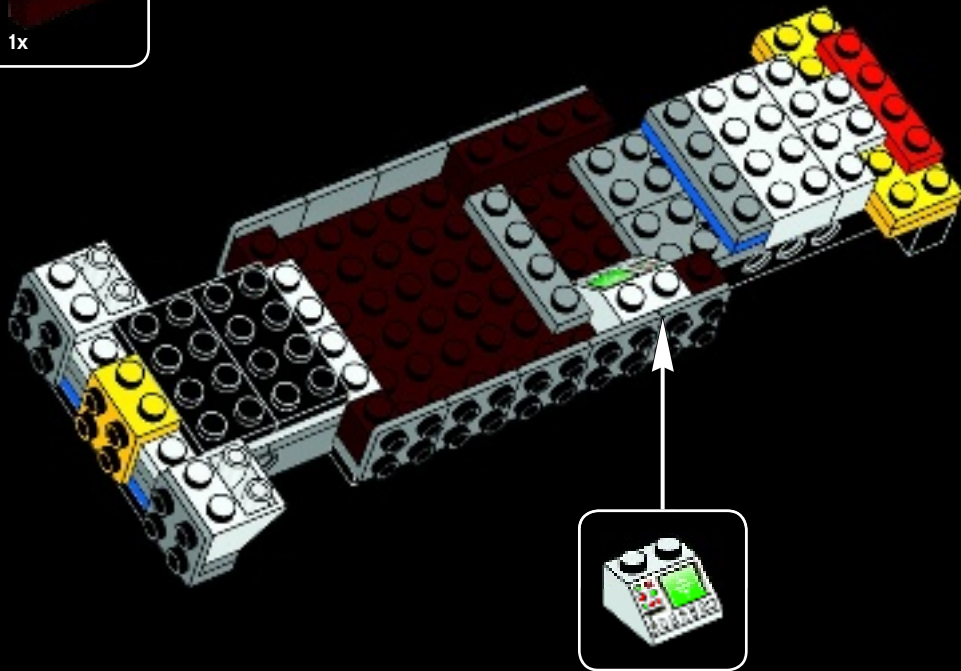



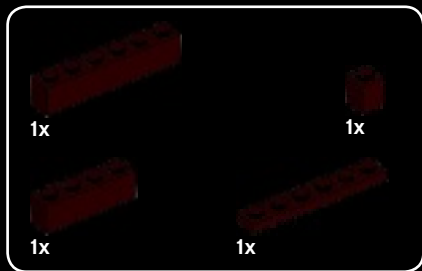

# 15

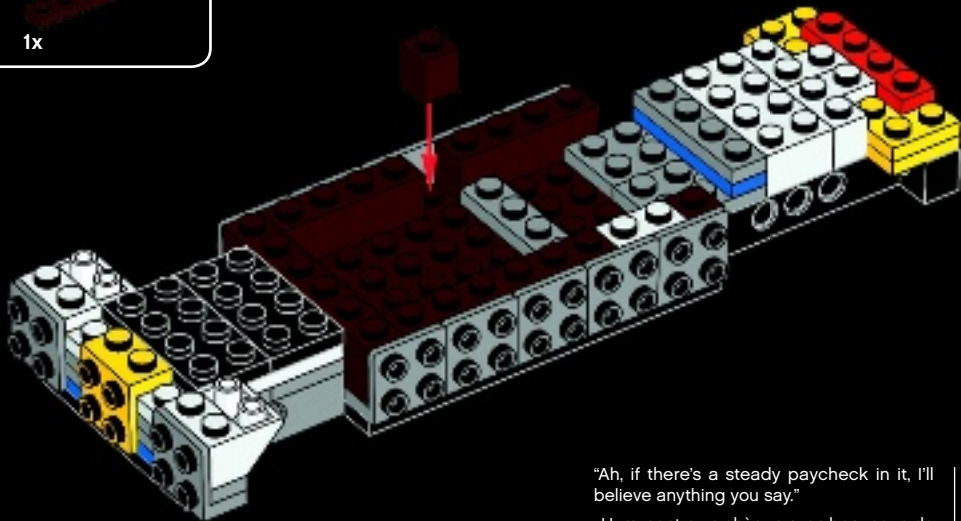

ZEDDEMORE

"Ah, if there's a steady paycheck in it, I'll believe anything you say."

«Hum, contre un chèque avec beaucoup de zéros je peux croire tout ce que vous dites.»

«Ah, si pagan bien, creéré en todo».

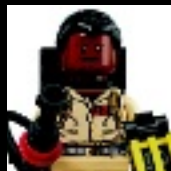



2x

# 16

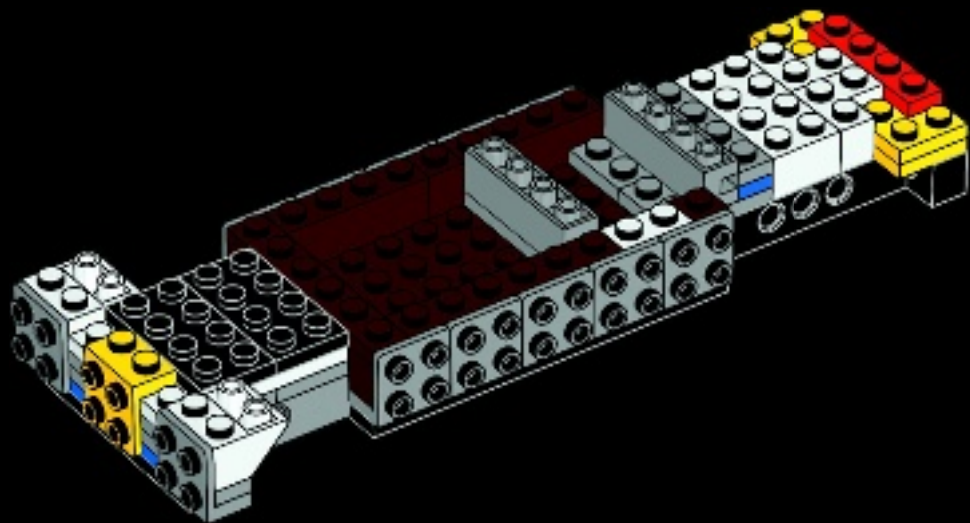

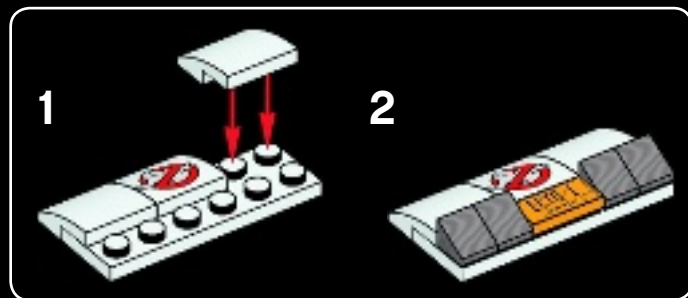
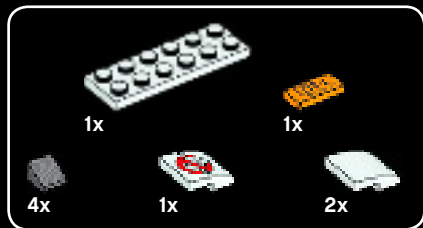

17

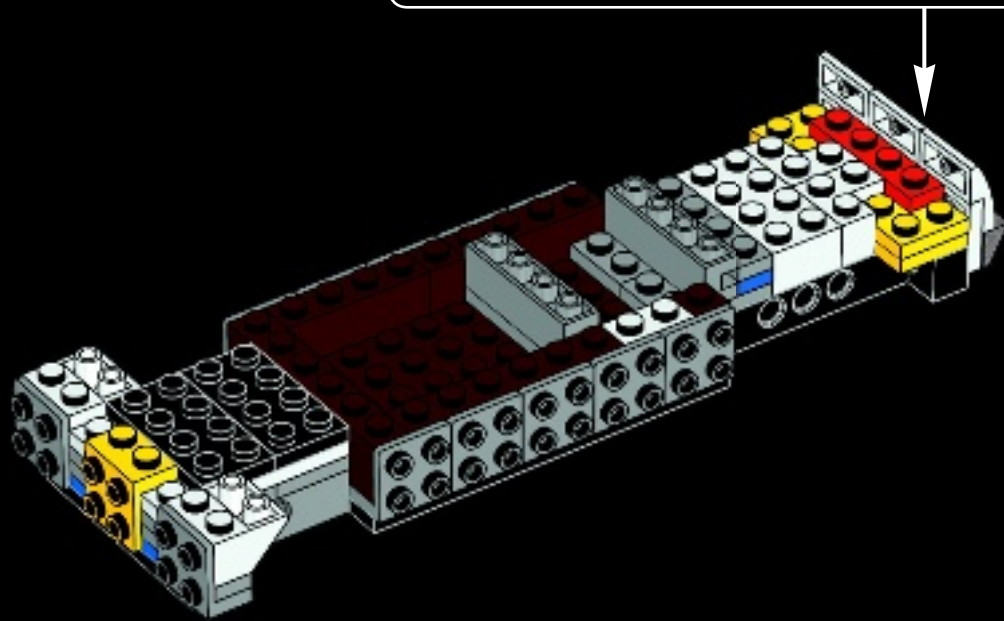



2x

18

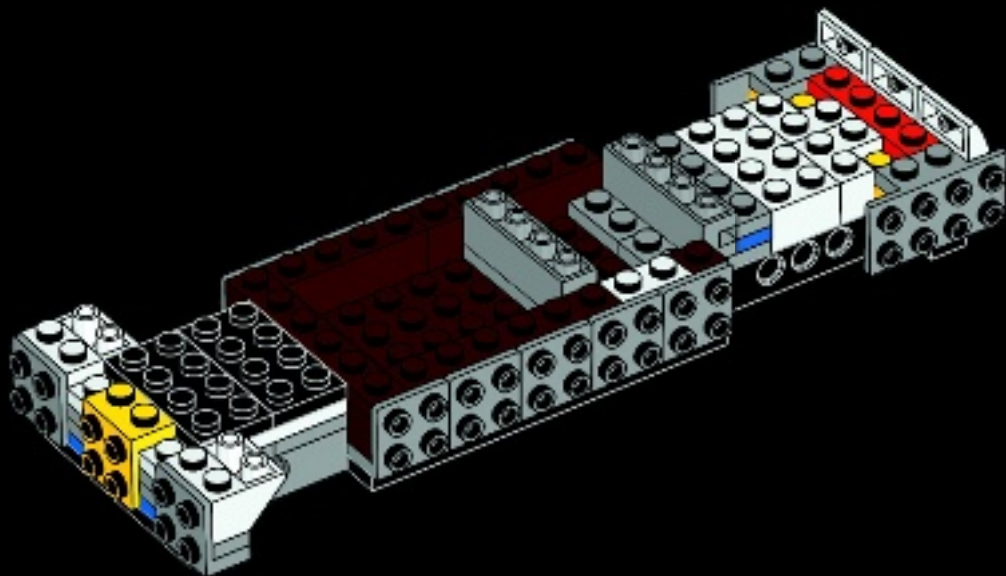



1x



2x

# 19

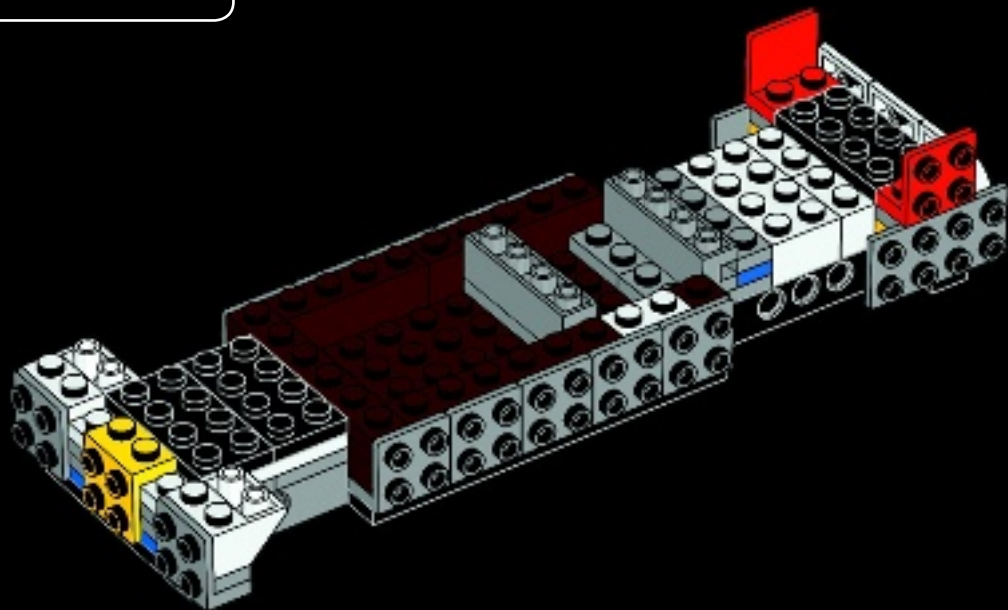



4x

20

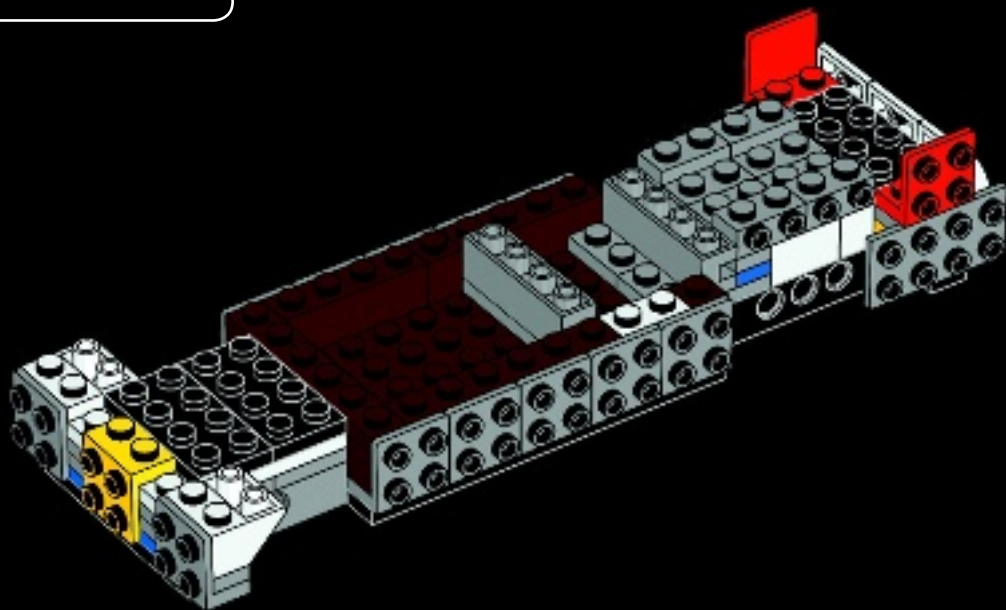



21

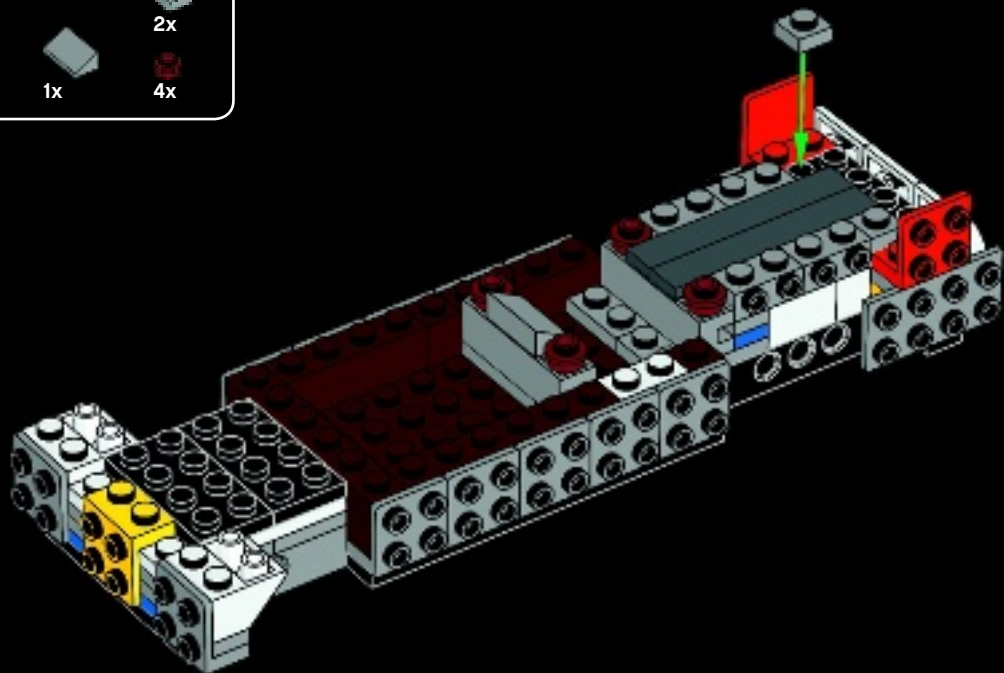

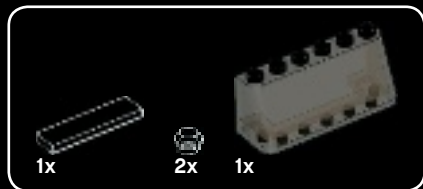

22

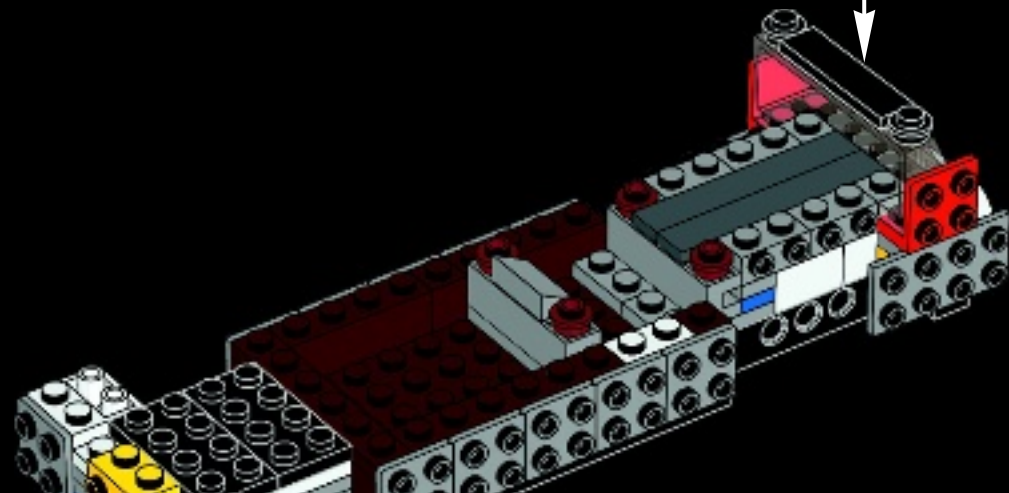
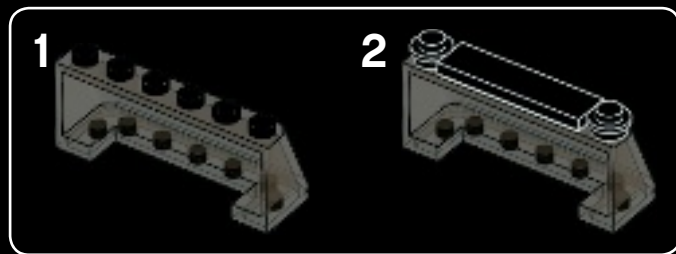





2x



2x

# 23

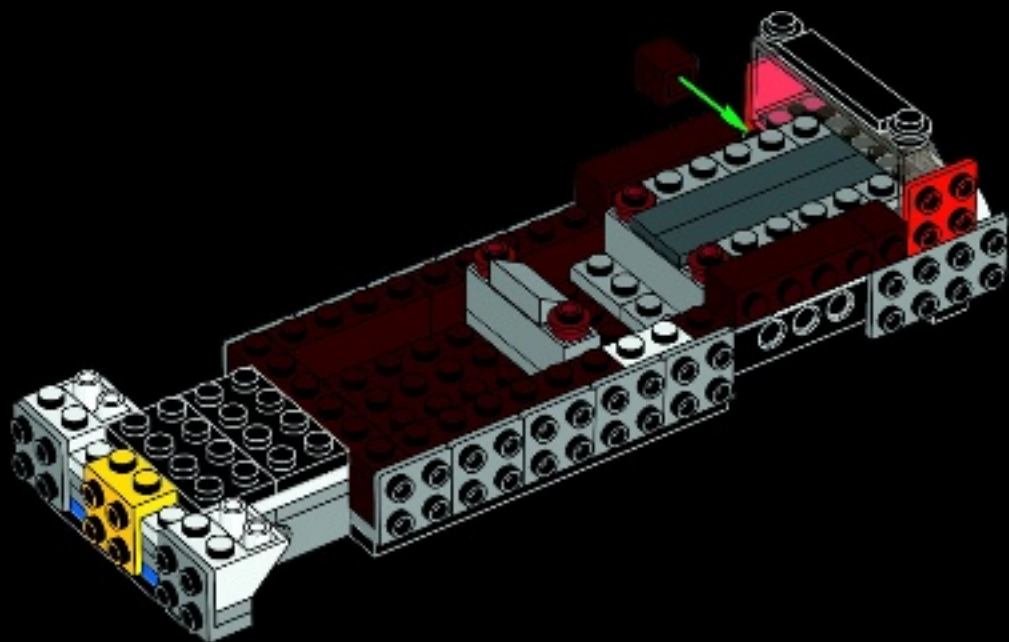



10x

24

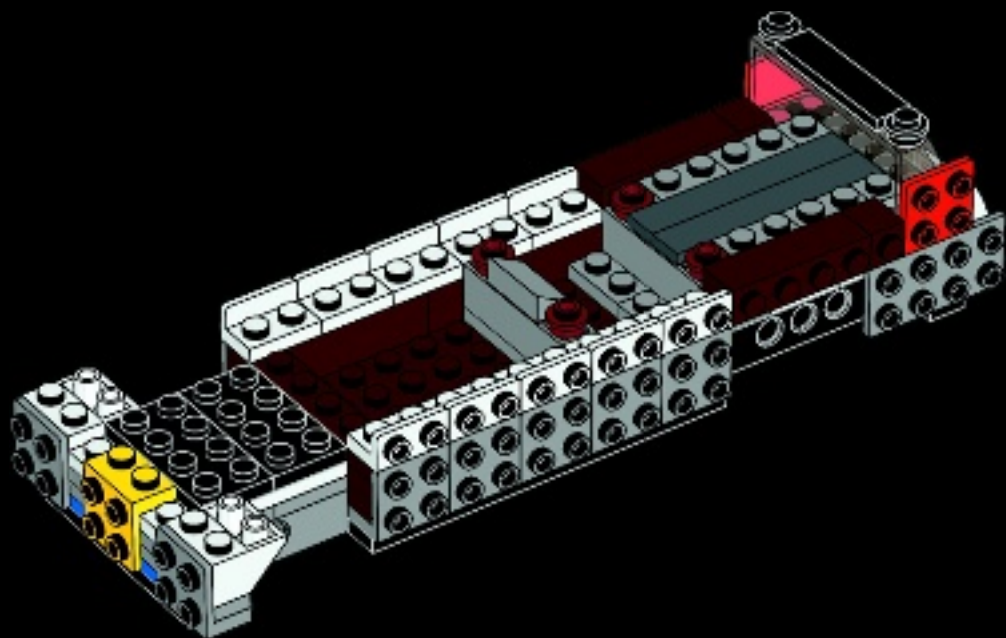



25

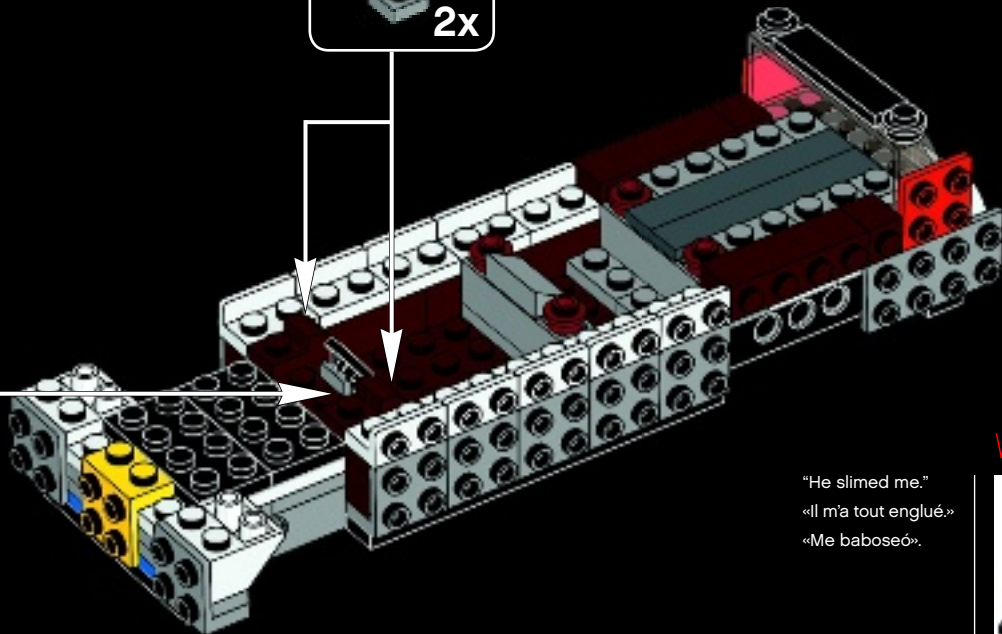

VENKMAN

"He slimed me."  
«Il m'a tout englué.»  
«Me baboseó.»





1x



2x

# 26

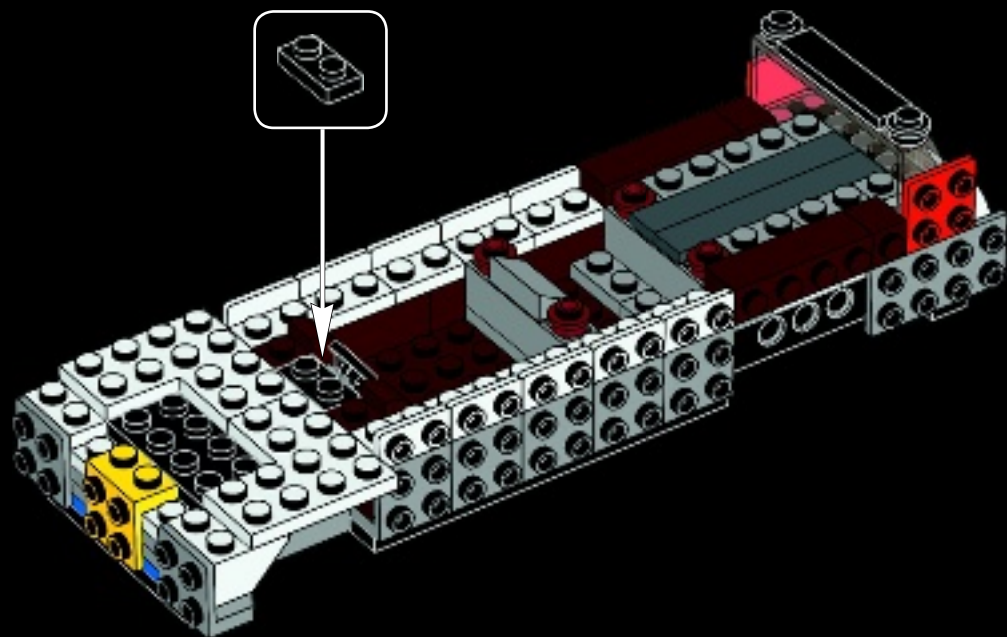



2x



1

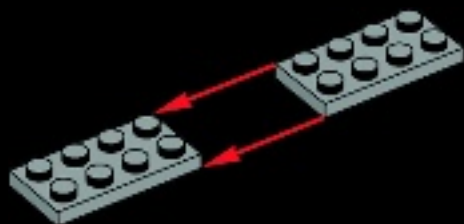

1x

2





3

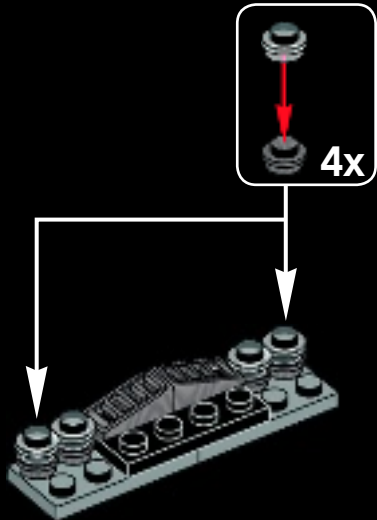

4



# 27

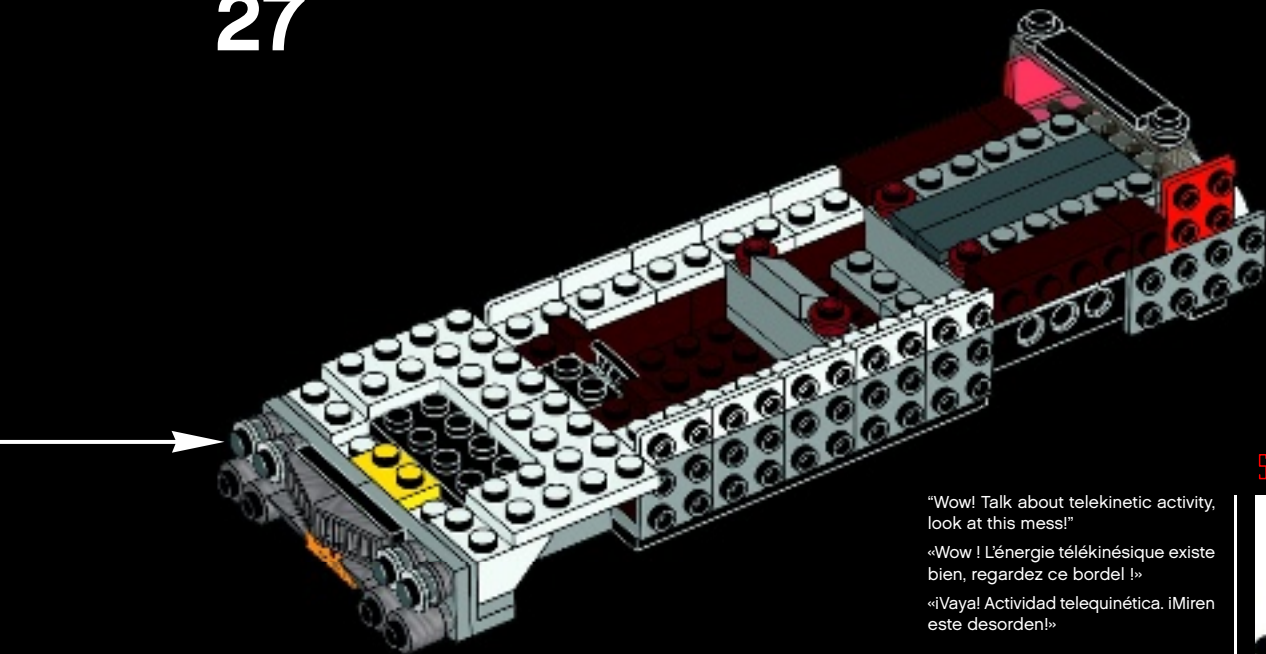

STANTZ

“Wow! Talk about telekinetic activity, look at this mess!”

«Wow ! L'énergie télékinésique existe bien, regardez ce bordel !»

«¡Vaya! Actividad telequinética. ¡Miren este desorden!»

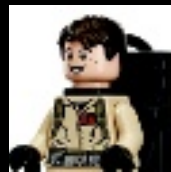



28

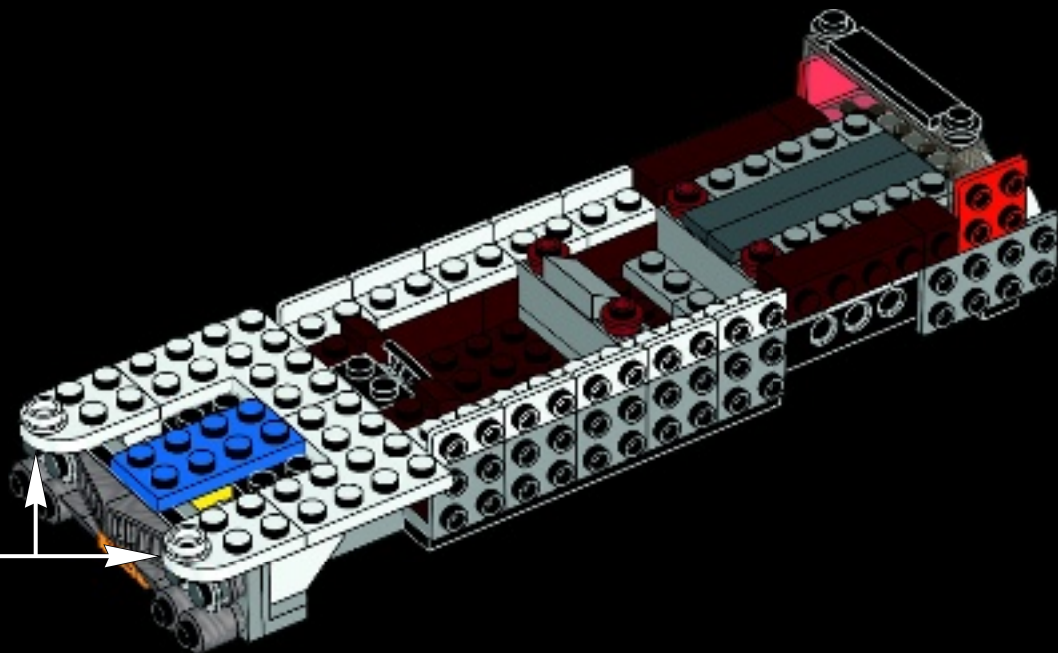





29

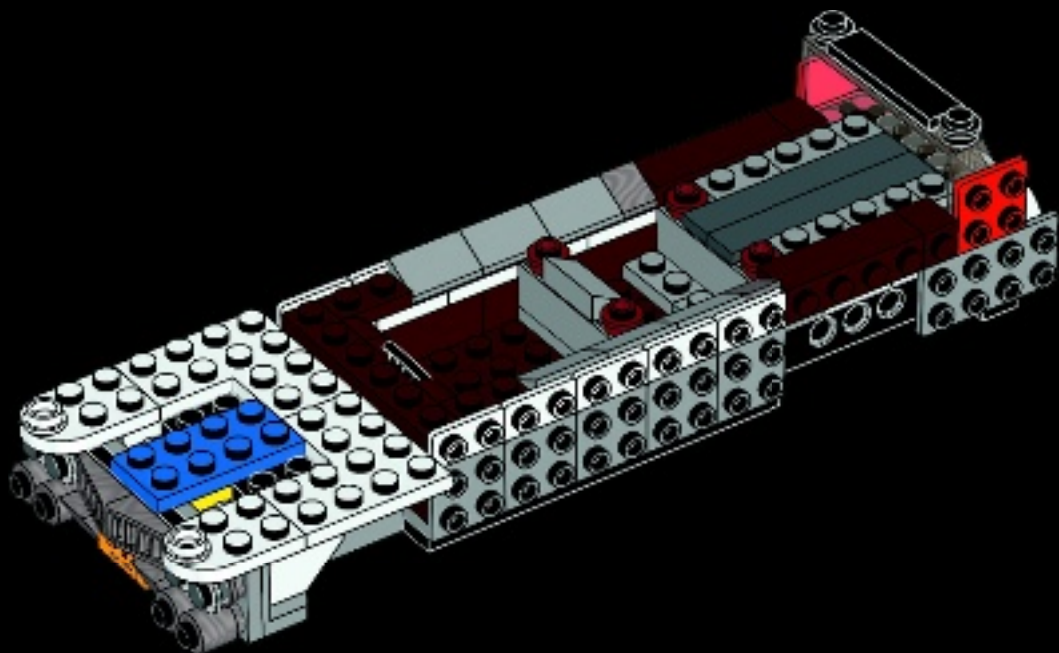



30

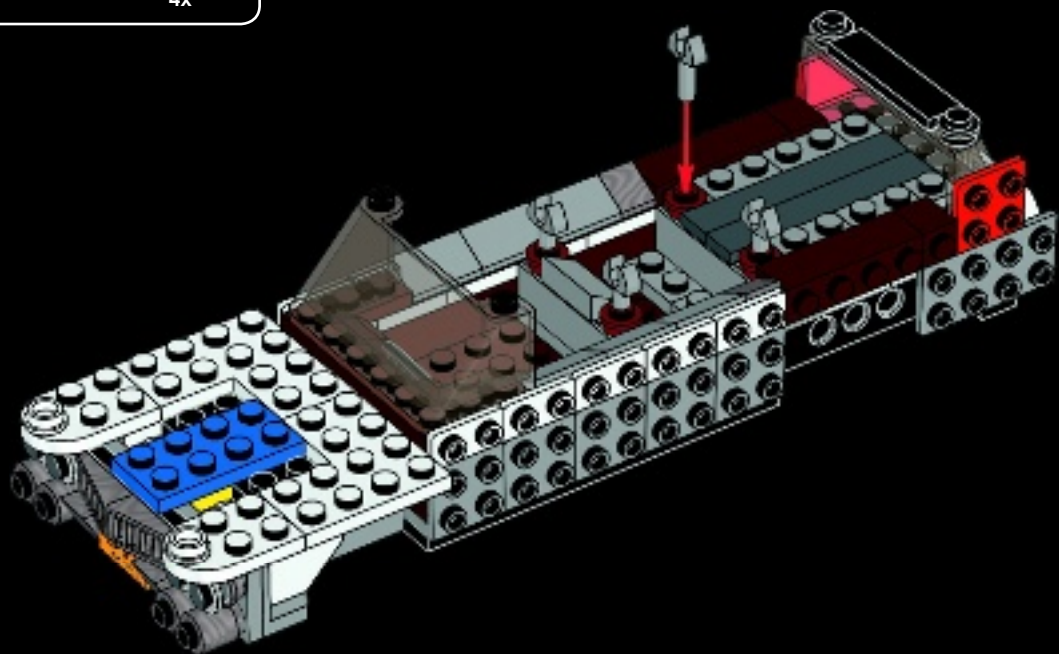

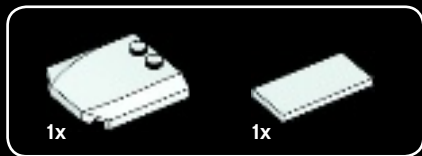

31

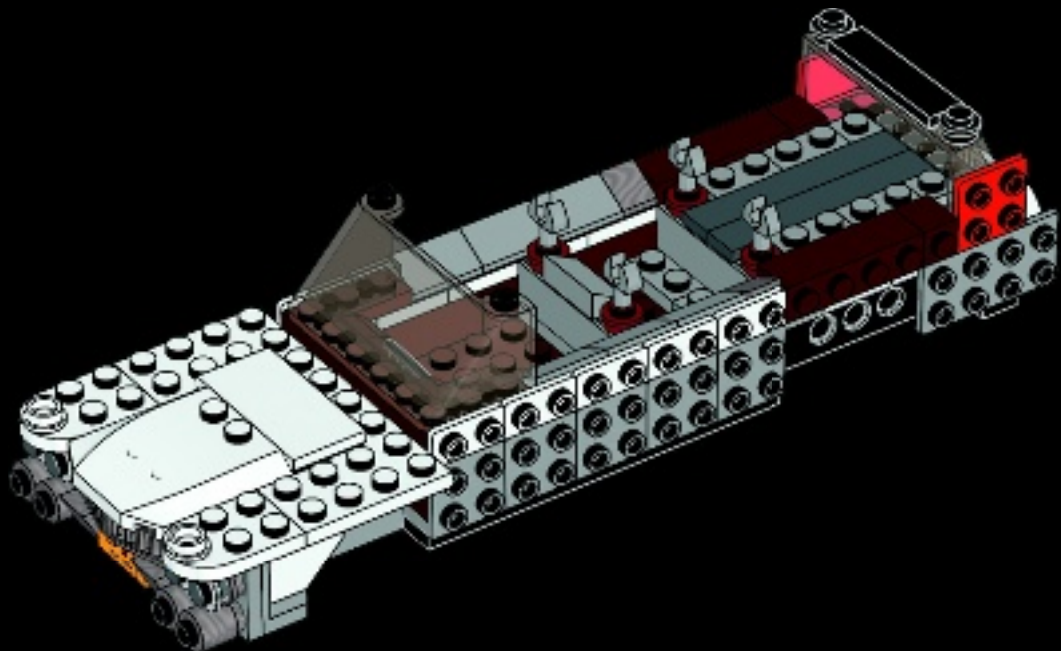



1x

2x

2x

2x

# 32

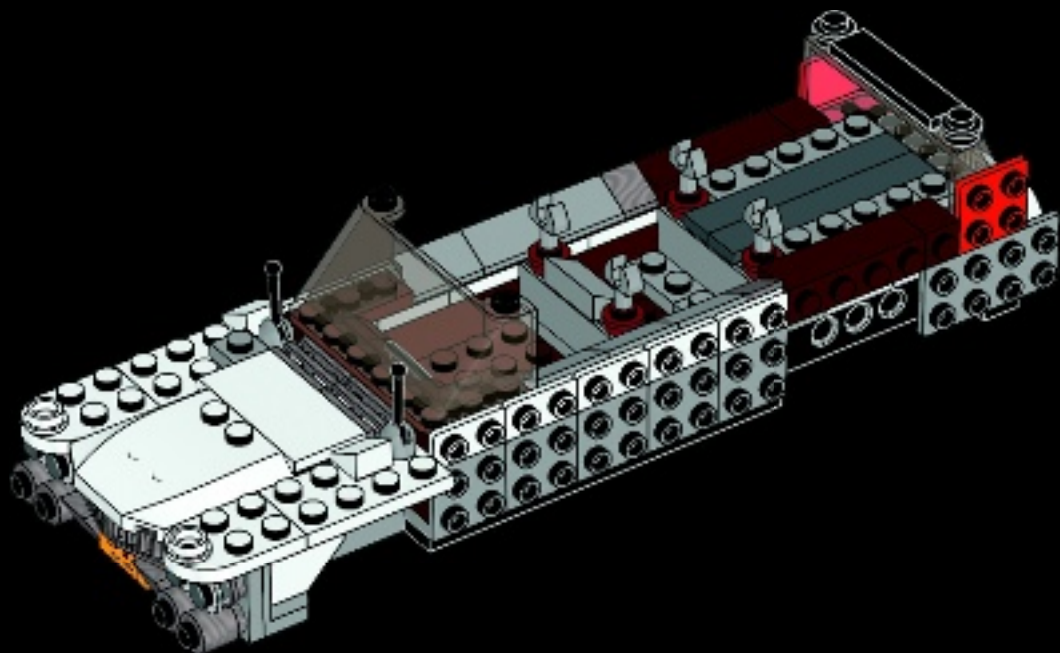



1x



2x

# 33

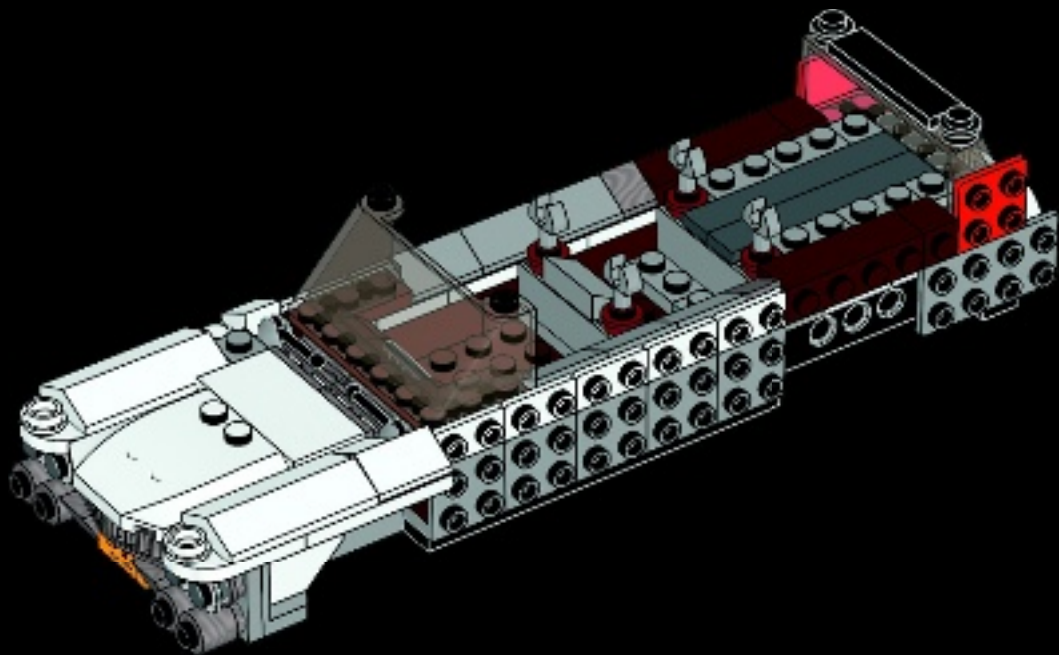



34

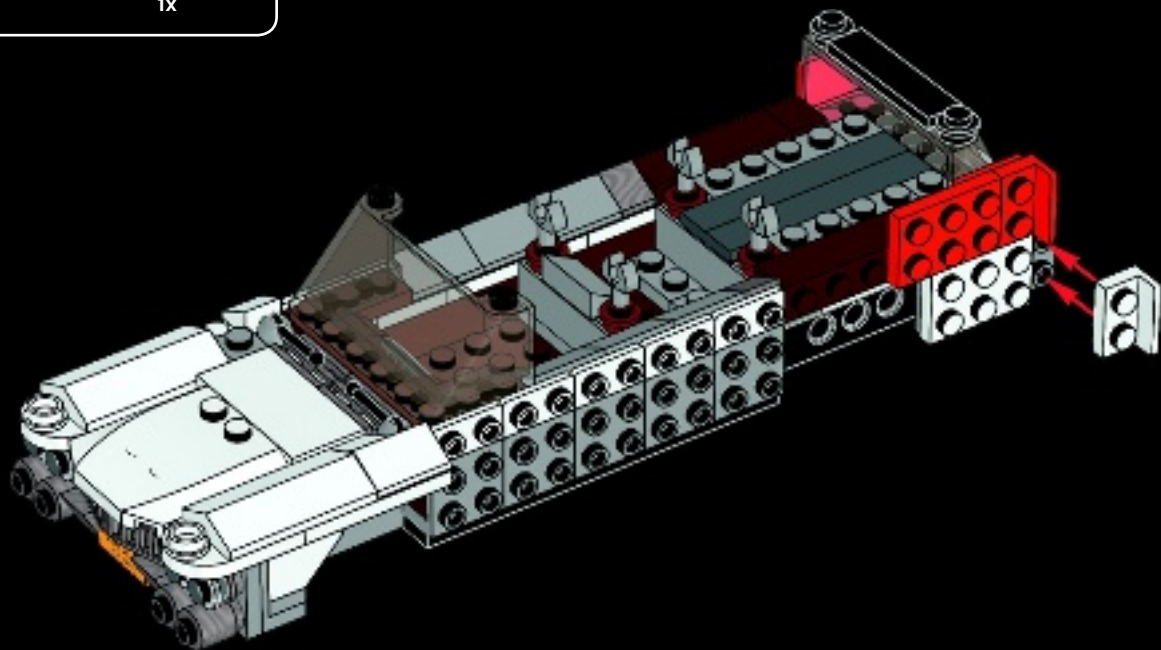

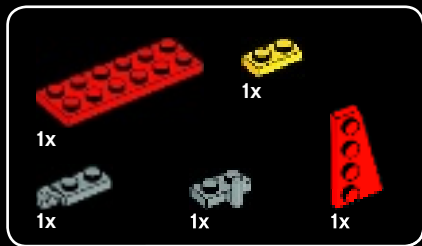

# 35

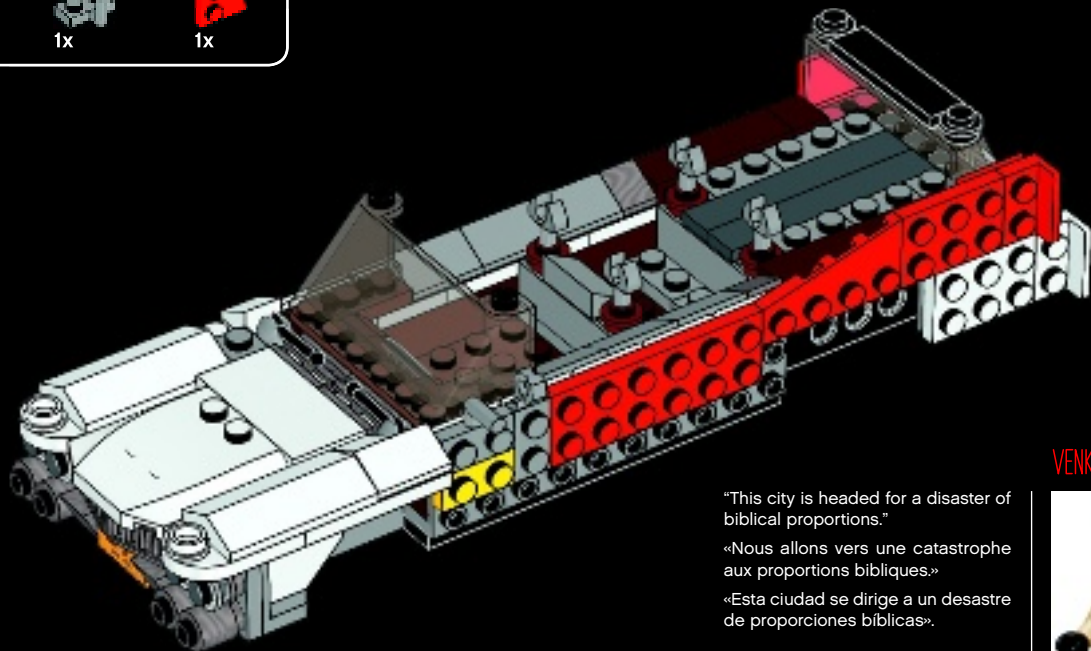

VENKMAN

"This city is headed for a disaster of biblical proportions."

«Nous allons vers une catastrophe aux proportions bibliques.»

«Esta ciudad se dirige a un desastre de proporciones bíblicas.»









37

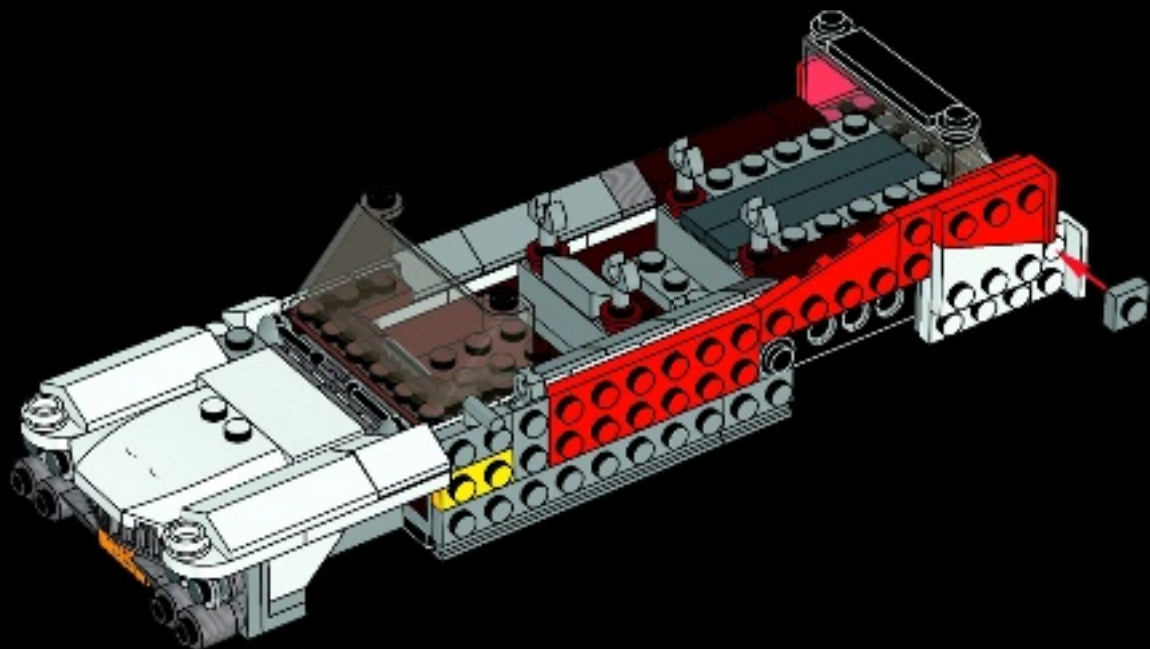



1x



1x

# 38

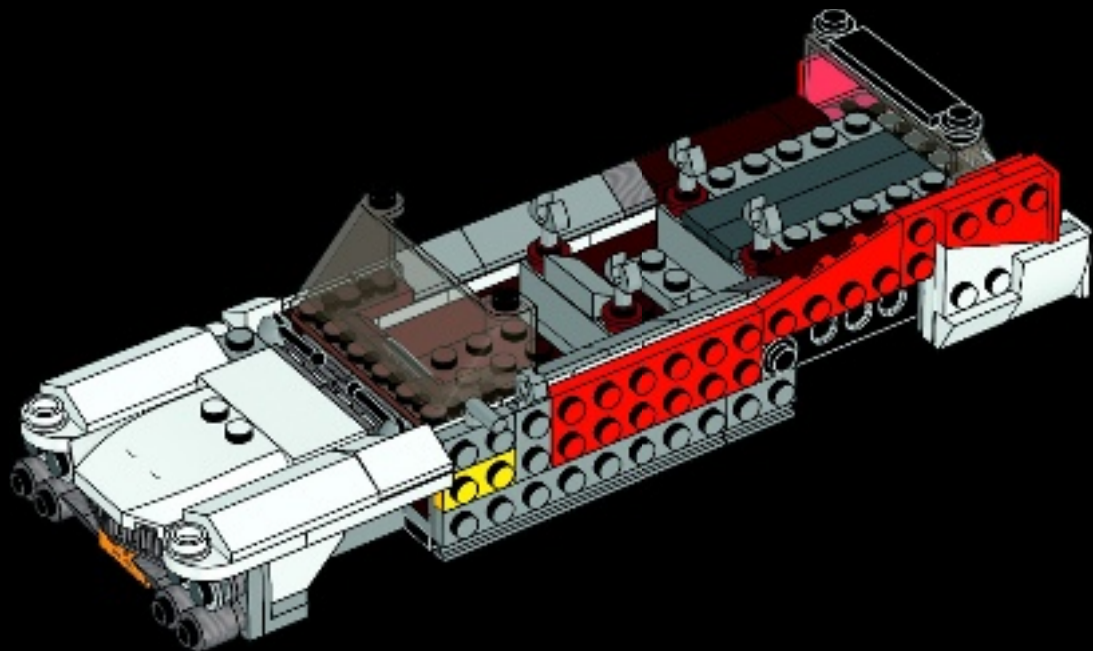



1x



2x

# 39

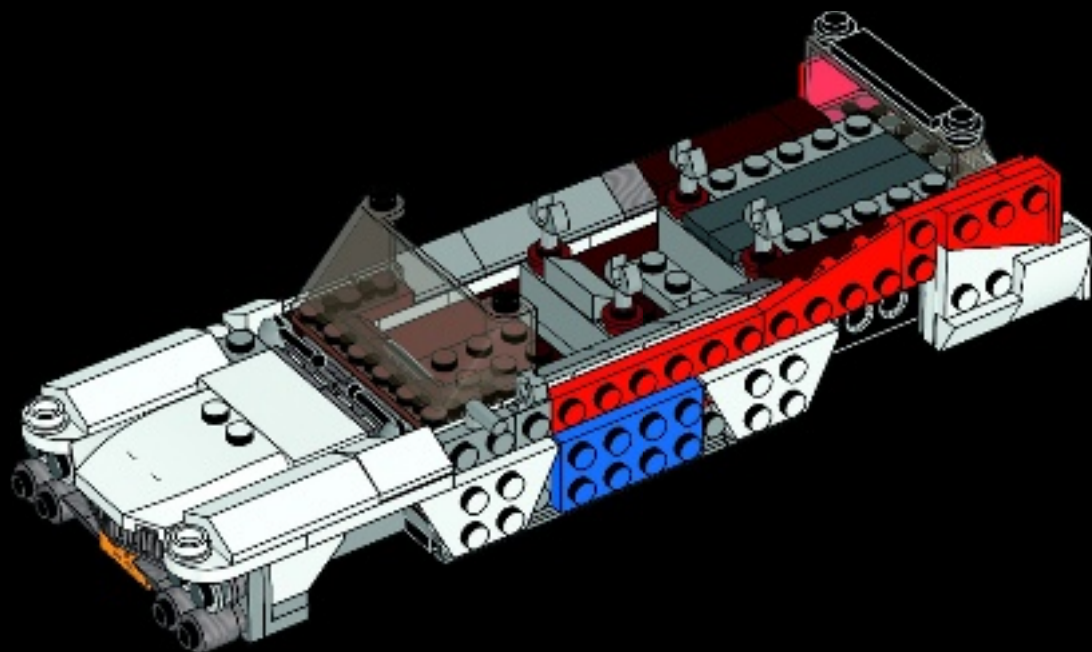



2x



2x

40

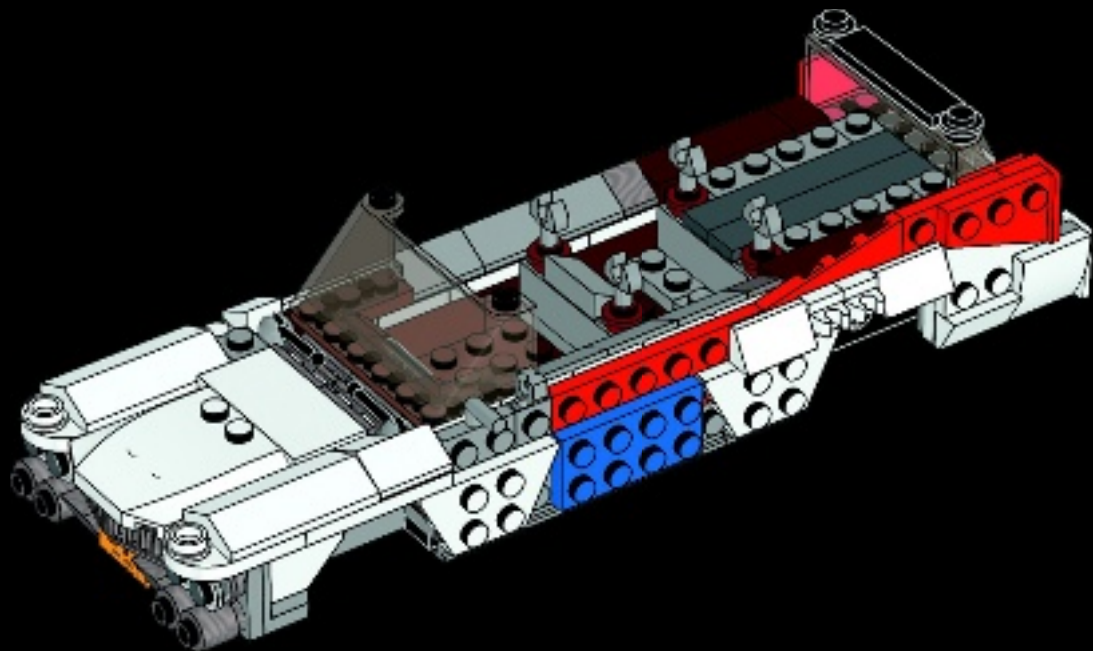

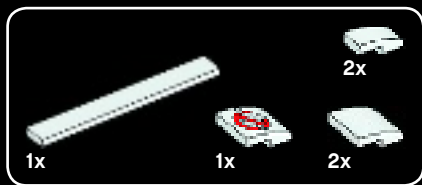

# 41

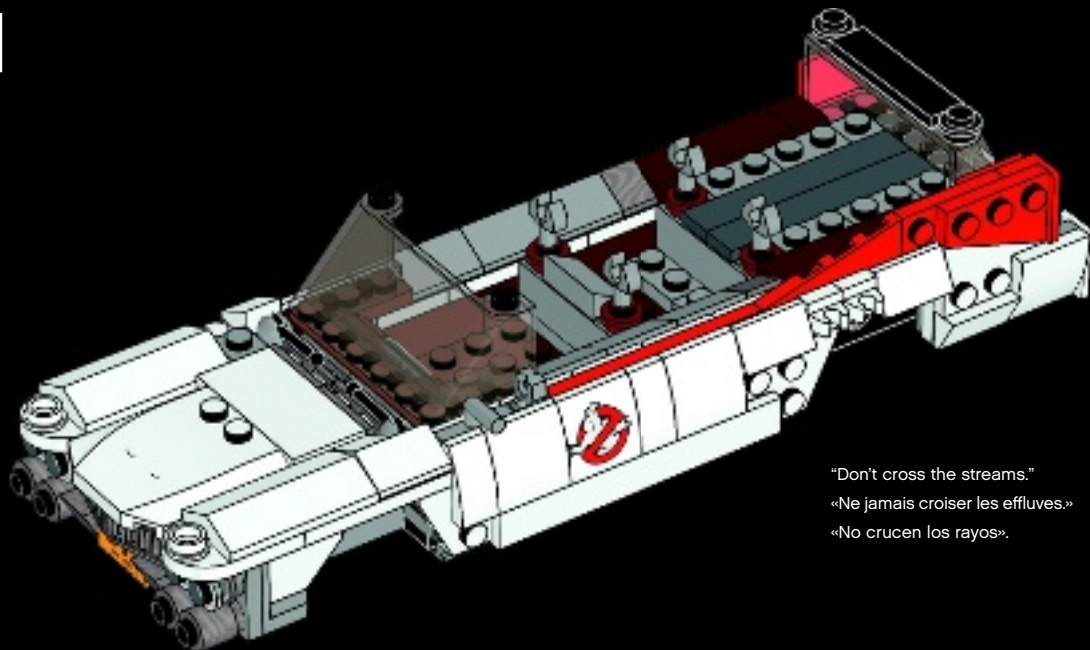

SPENGLER

"Don't cross the streams."  
 «Ne jamais croiser les effluves.»  
 «No crucen los rayos.»





42

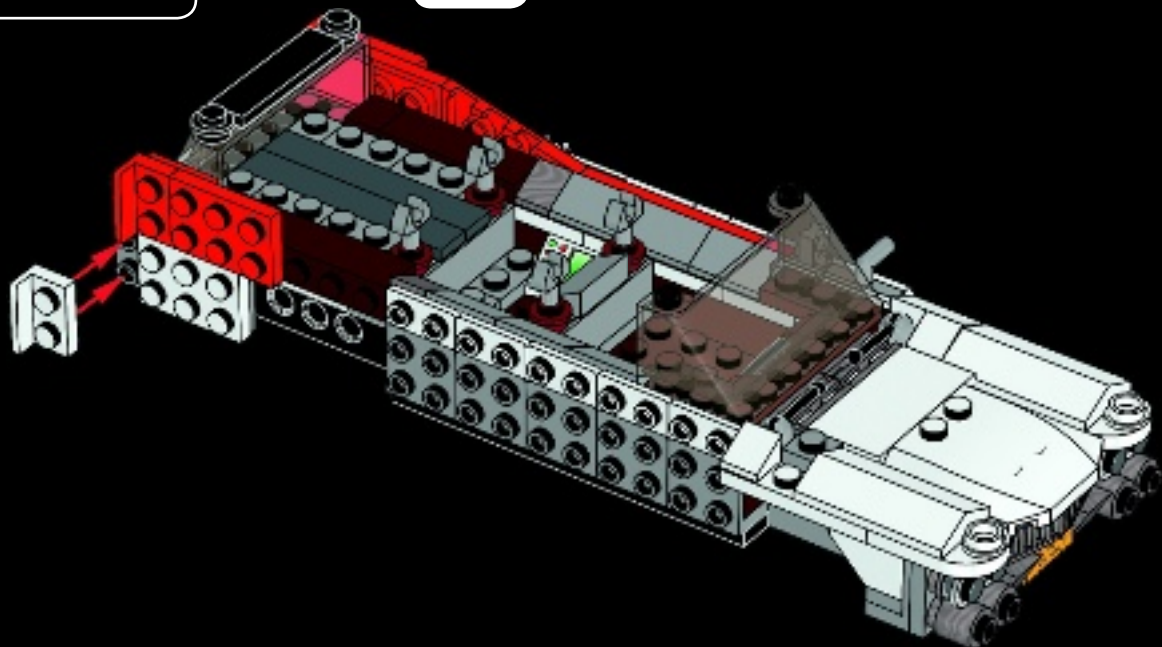

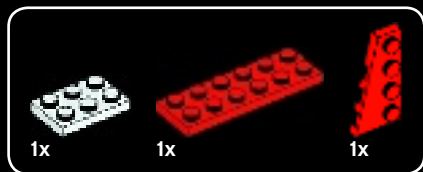

43

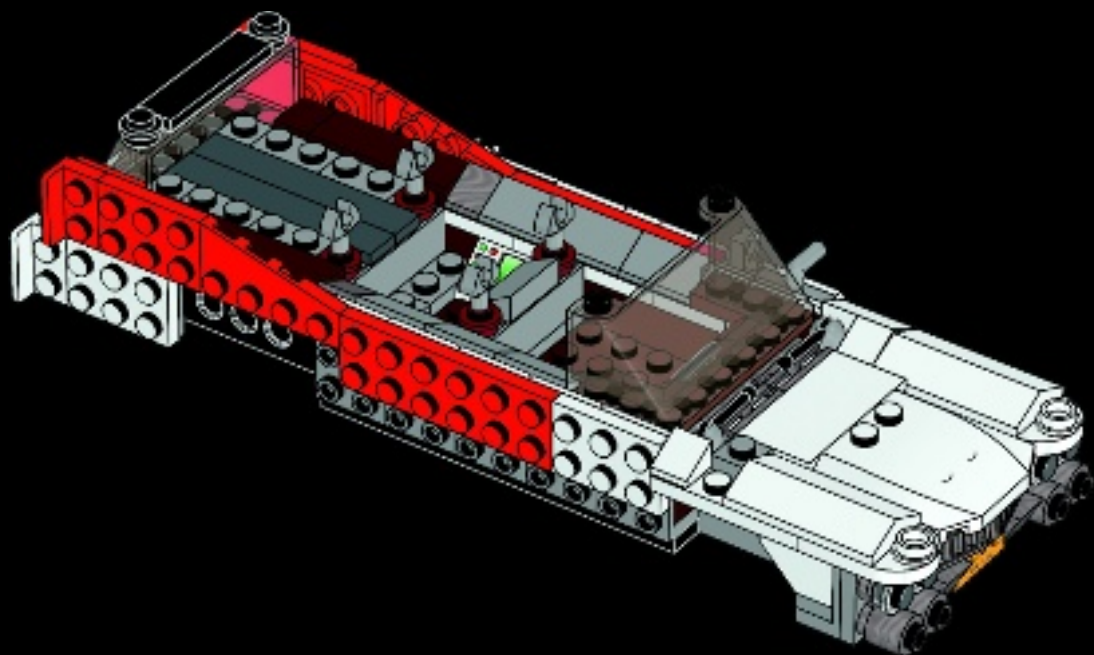

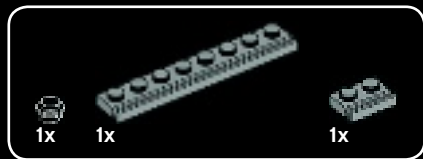

44

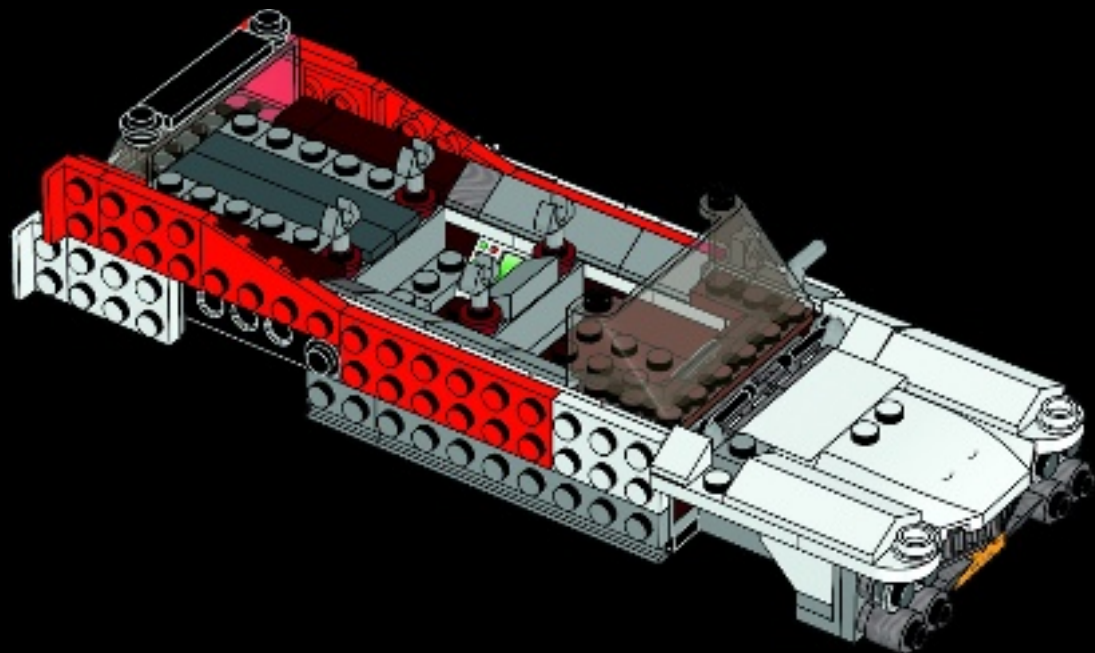





45

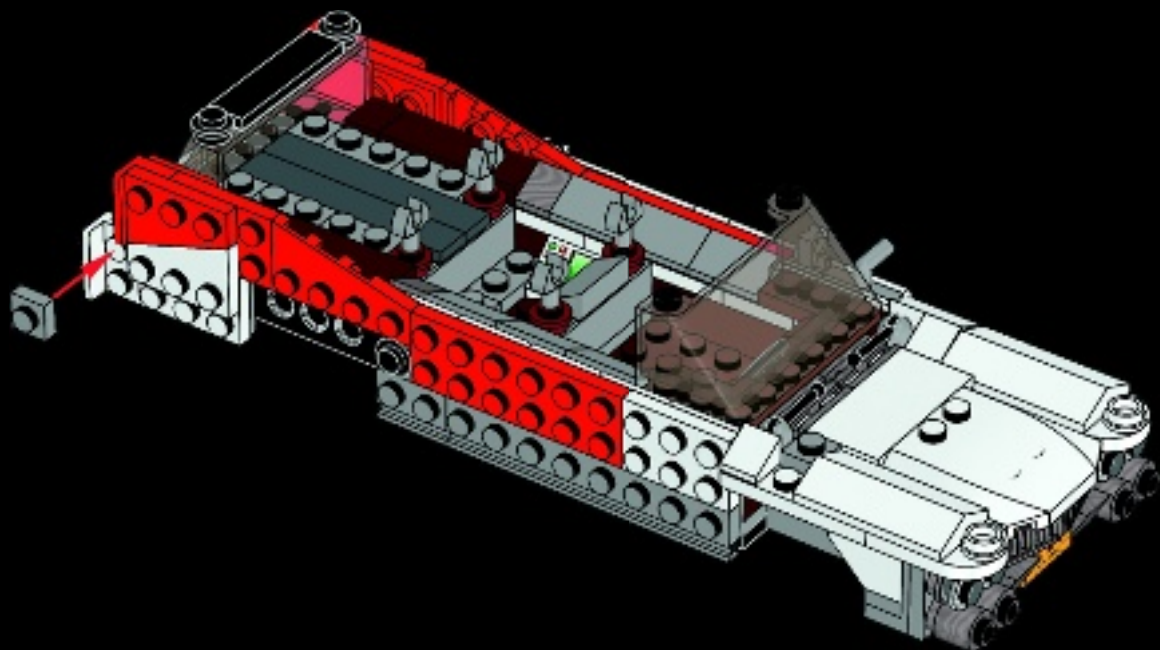



1x



1x

# 46

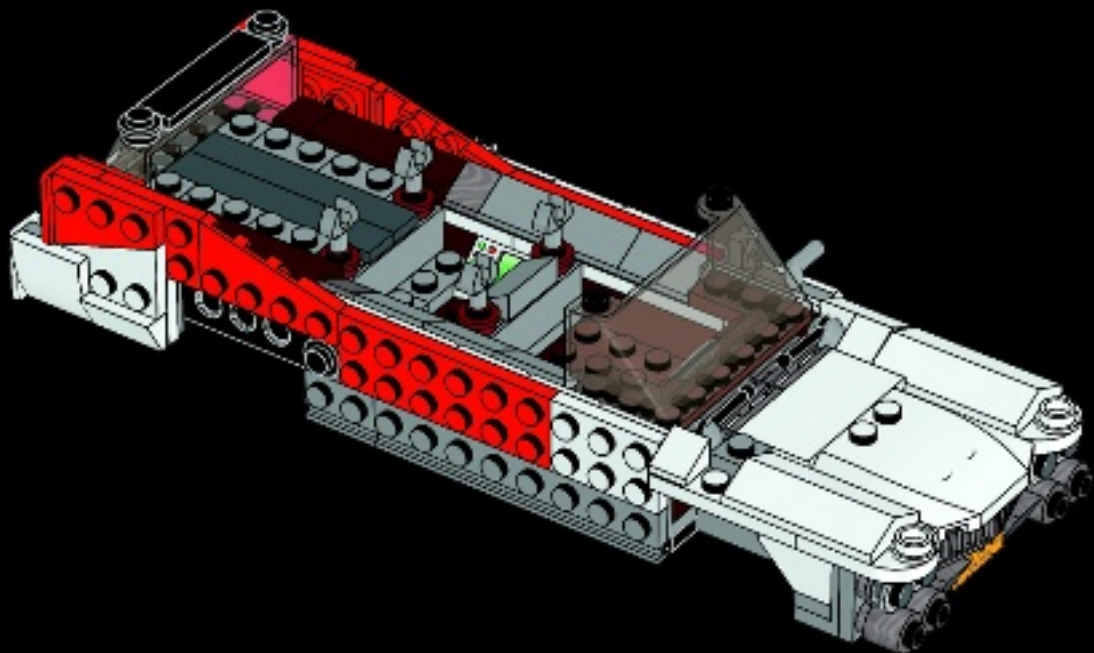



3x

47

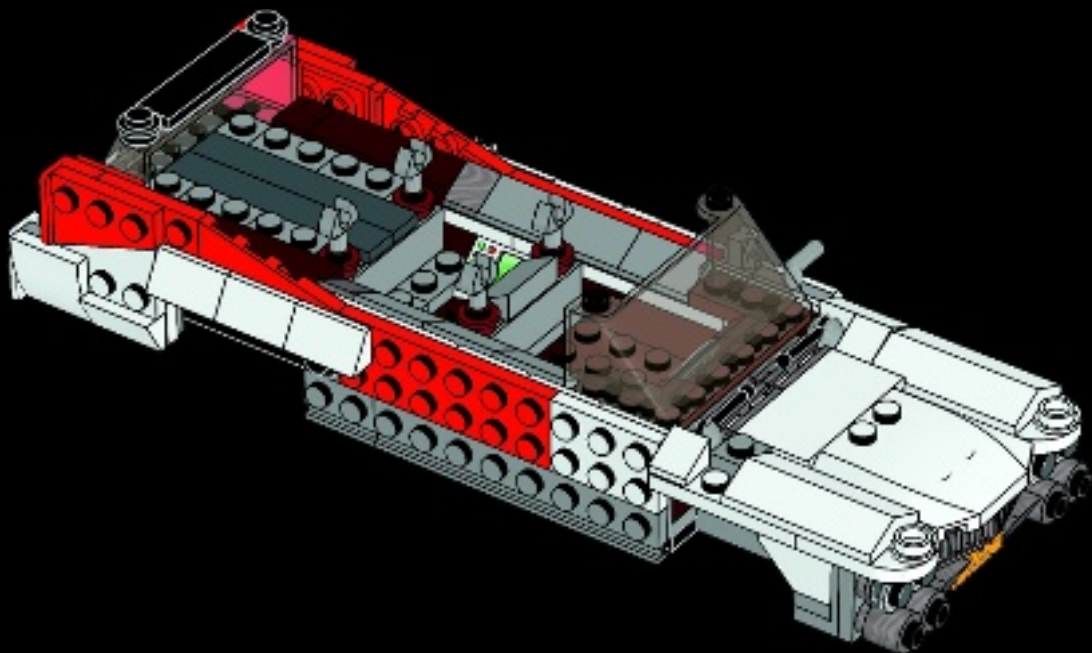



1x



2x

# 48

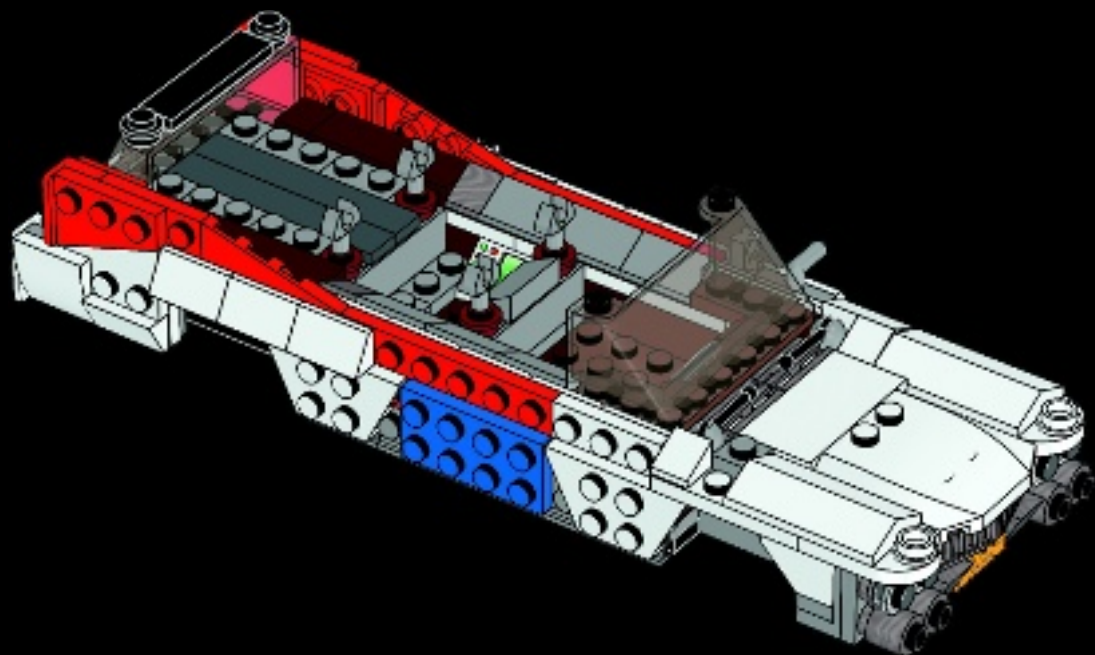

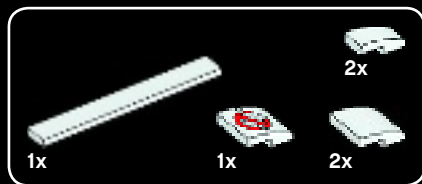

49

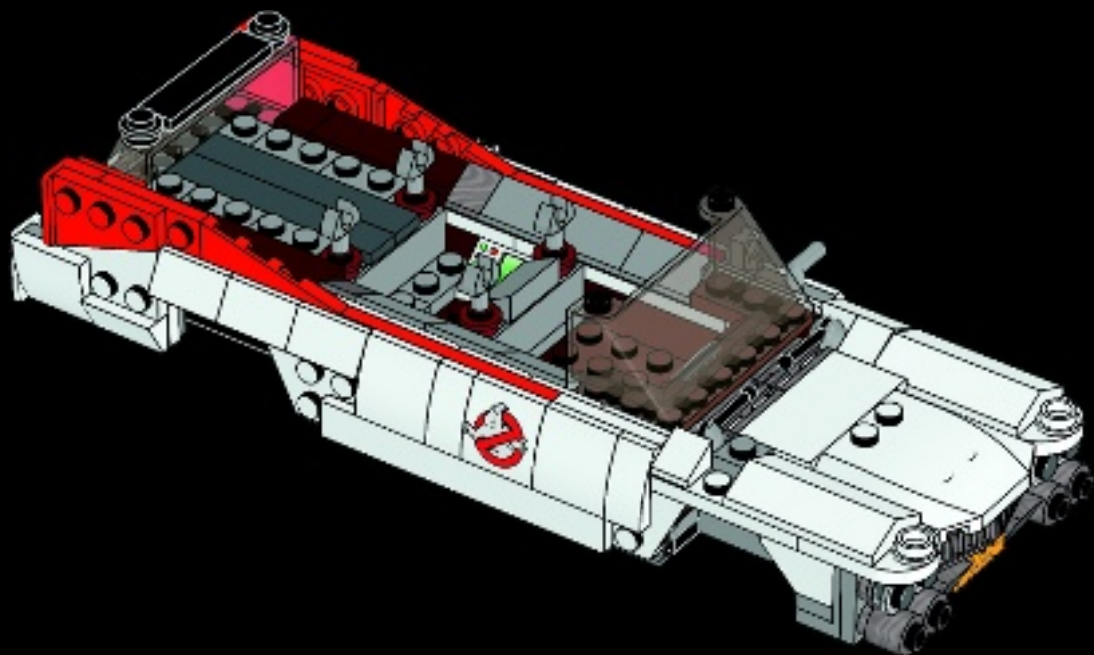



2x



2x

50

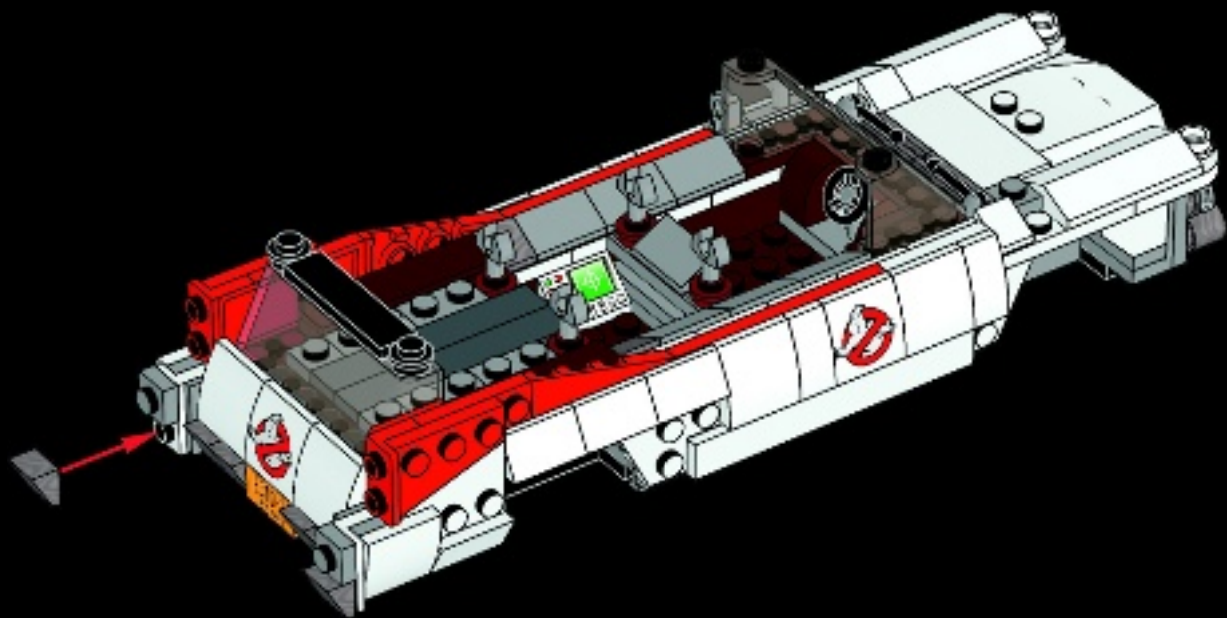



2x



2x



2x

# 51

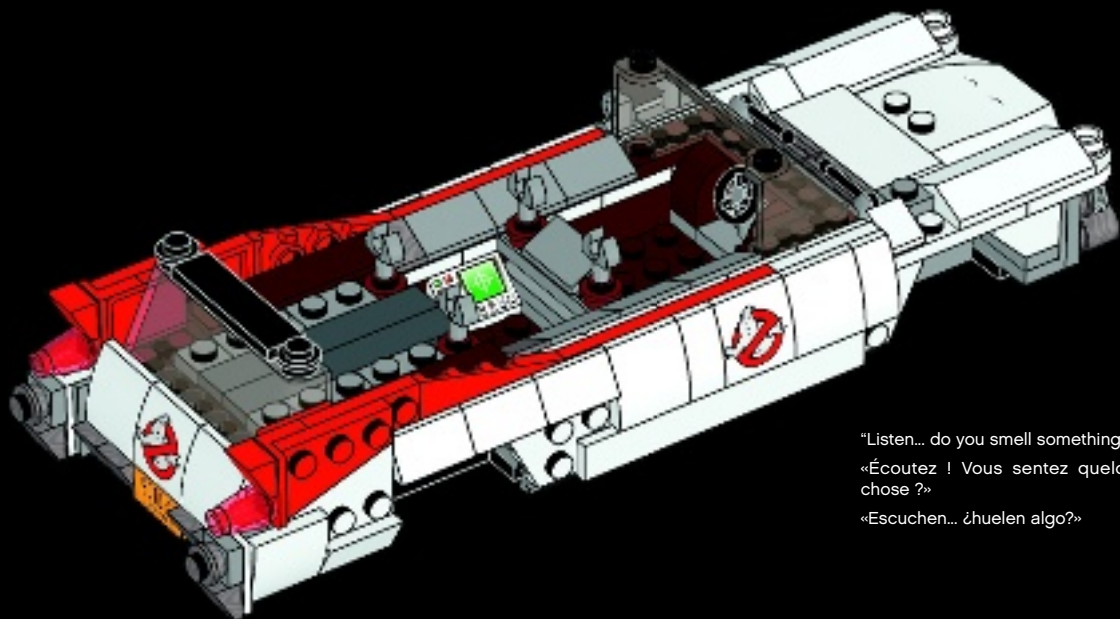

"Listen... do you smell something?"  
«Écoutez ! Vous sentez quelque chose ?»  
«Escuchen... ¿huelen algo?»

STANTZ

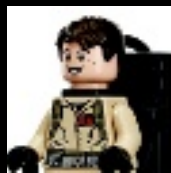



10x

52

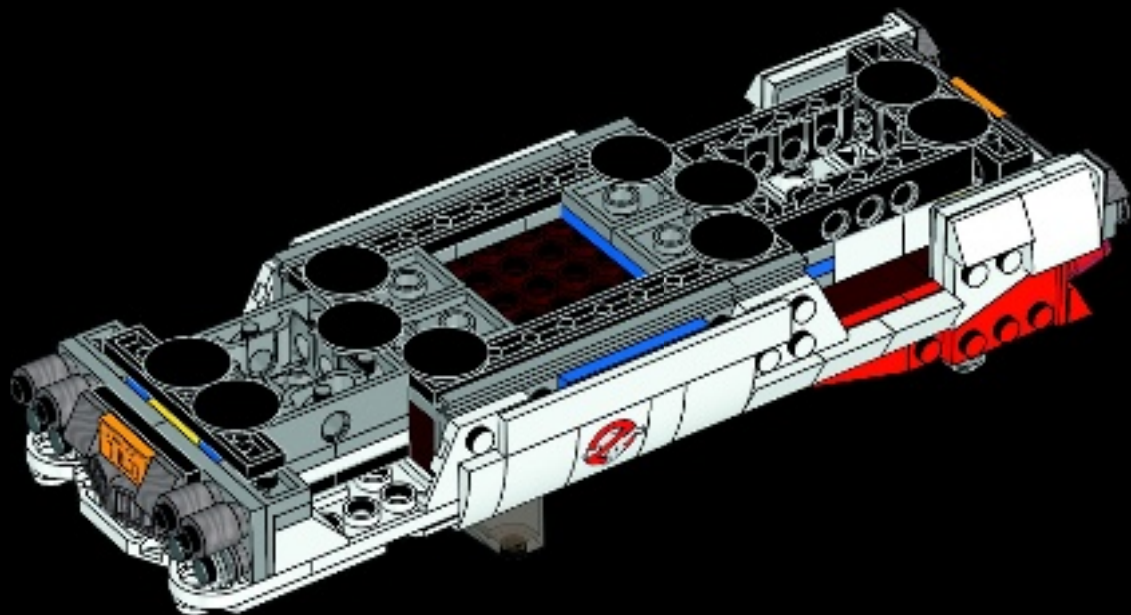





53

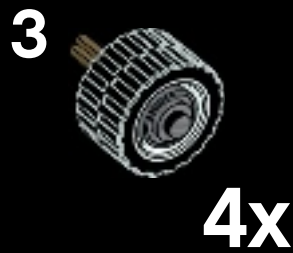
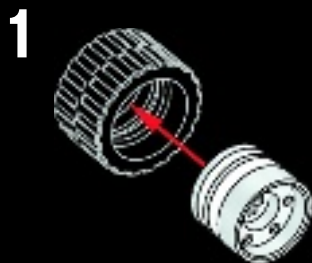

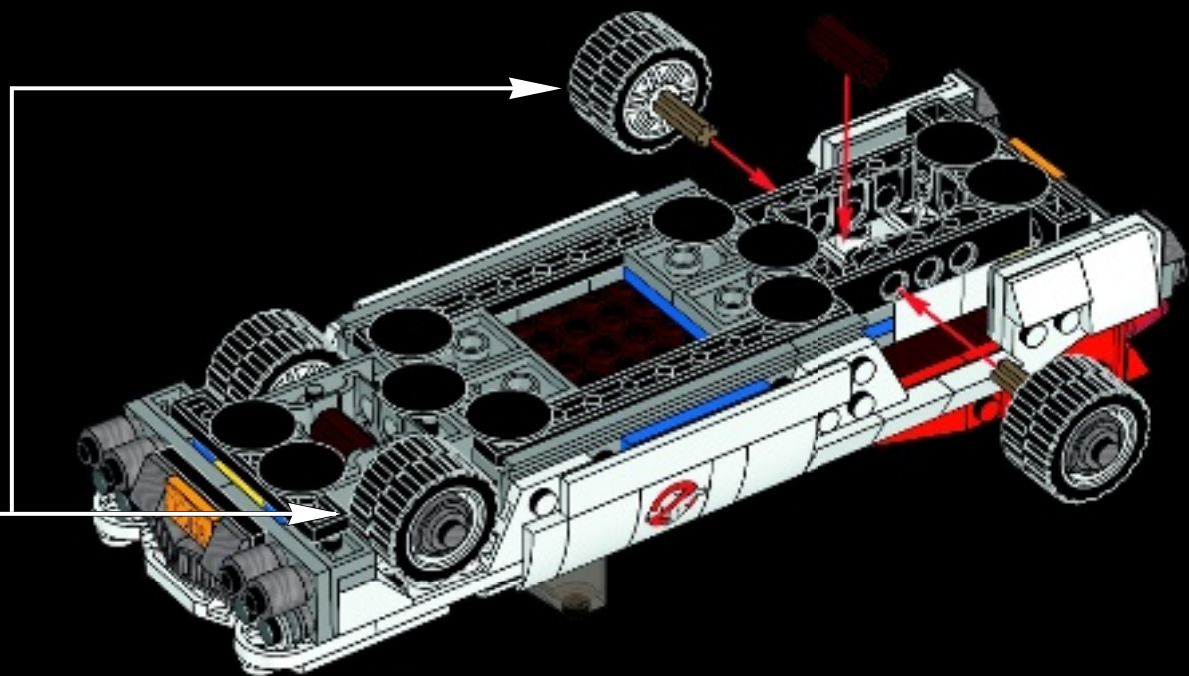



54

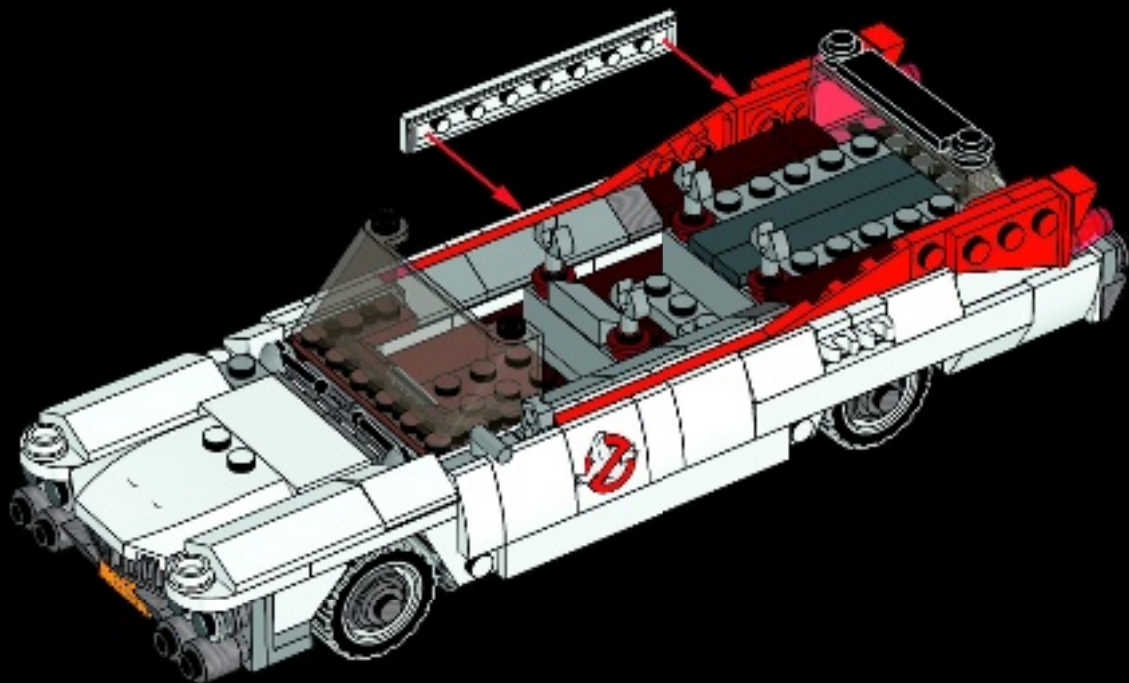

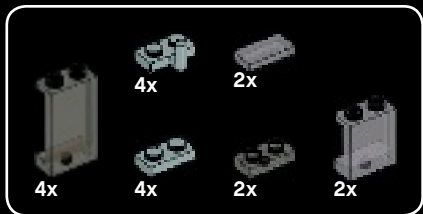
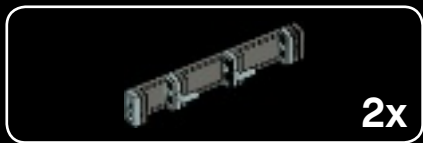

55

1

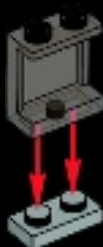

2



3



4



5



2x

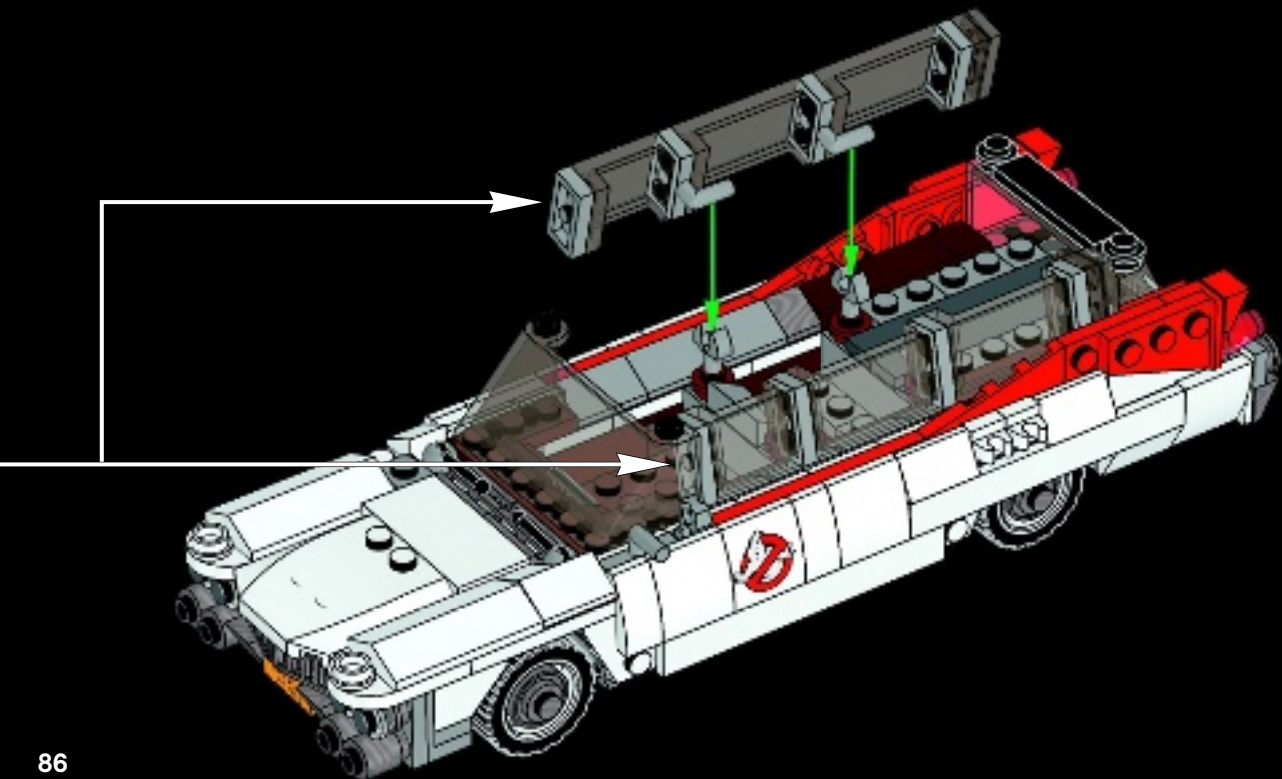



56

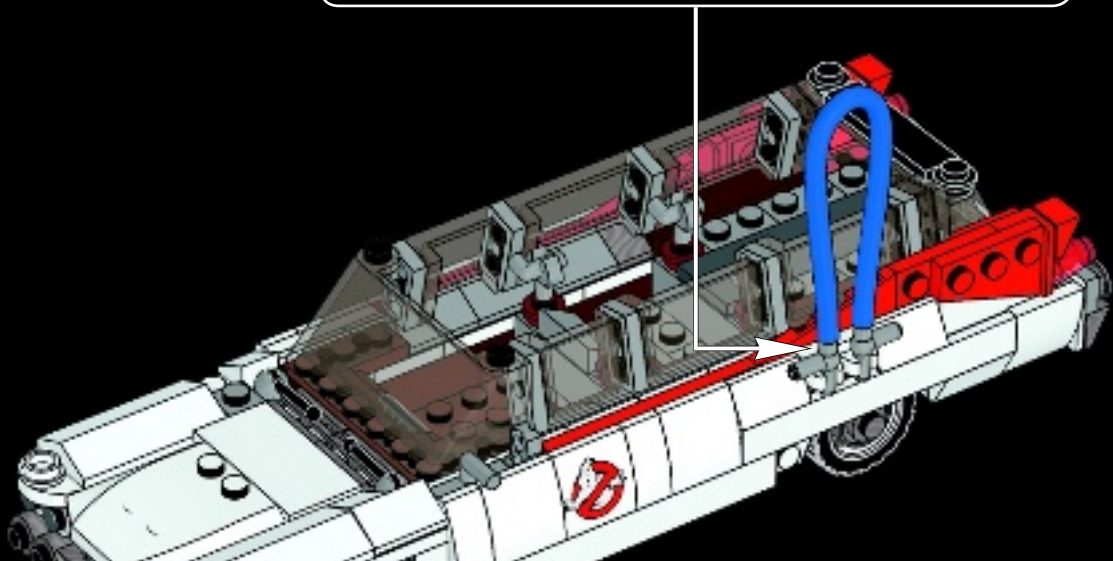

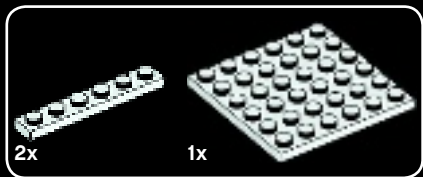

1

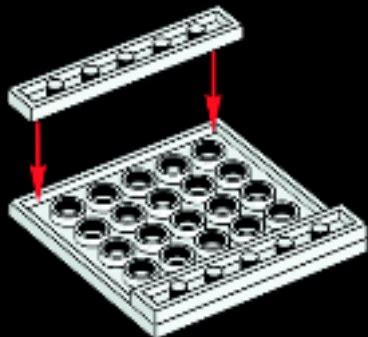

2







3



4

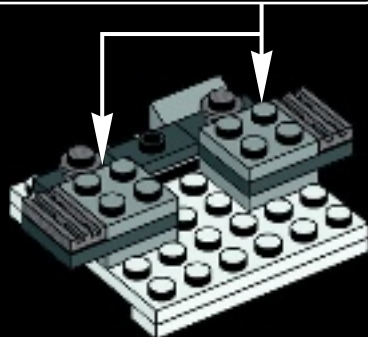
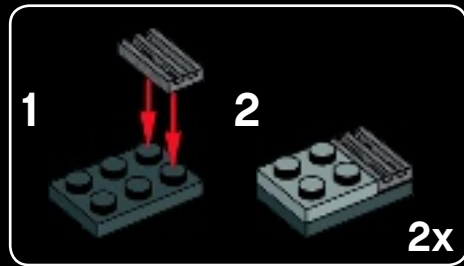



2x



1x



1x

1

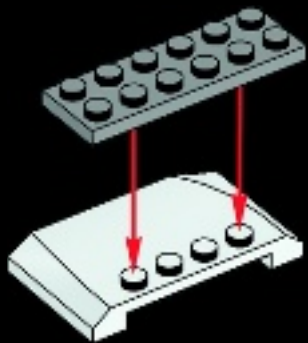

8x

2





1x



1x

3

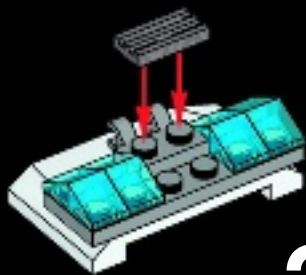

2x

5

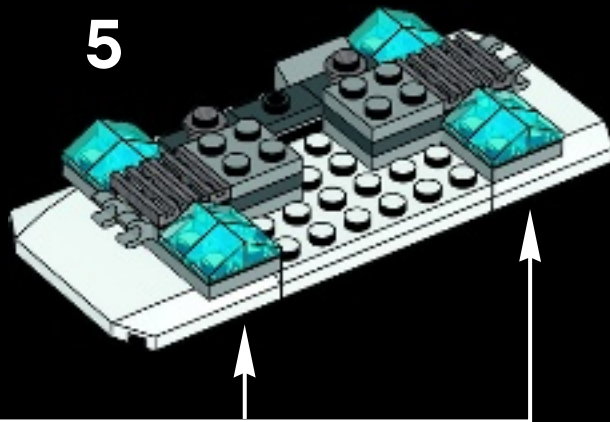

SPENGLER

"I'm terrified beyond the capacity for rational thought."

«La terreur annihile toutes mes facultés conceptuelles.»

«Estoy aterrizado y perdí la capacidad de tener pensamientos racionales».



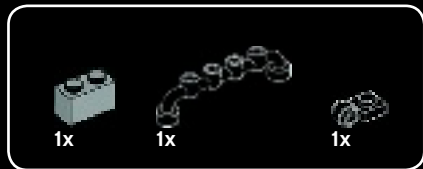

6

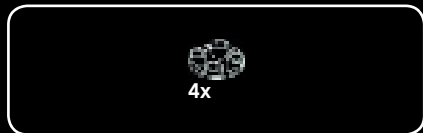
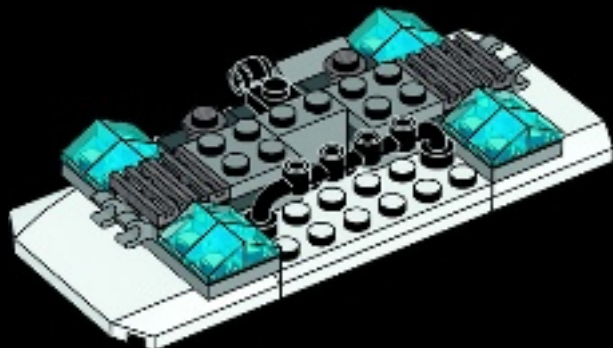

7

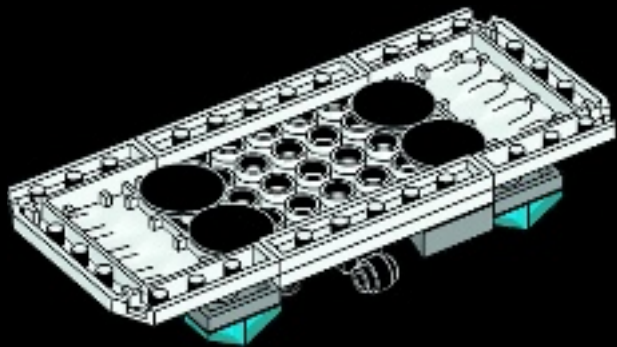



8

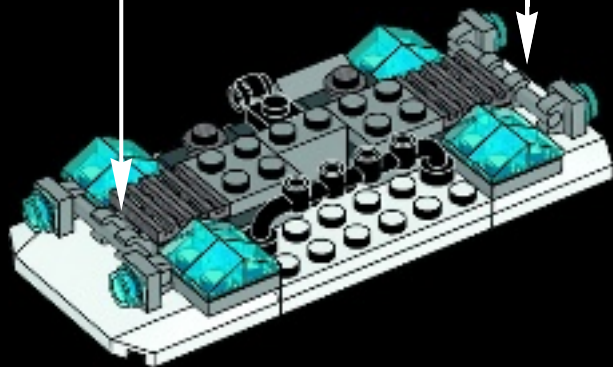



2x



2x



2x



2x

9

1



2



2x

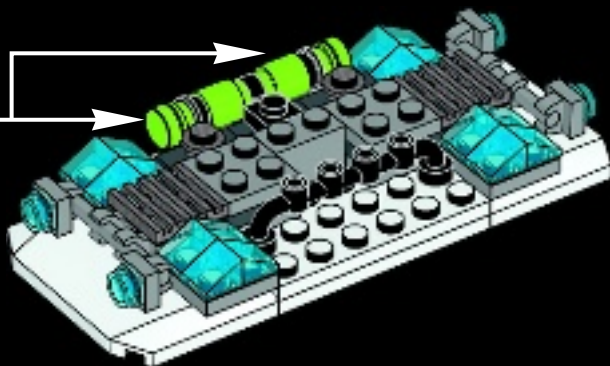

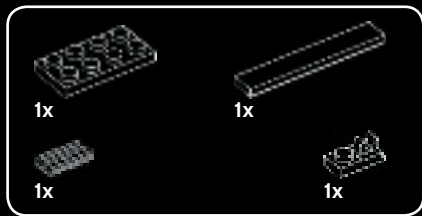

10

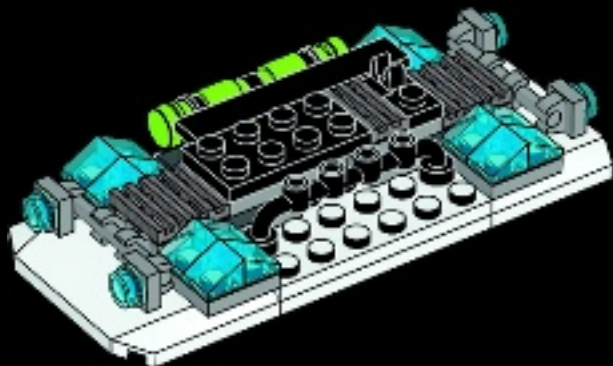

11

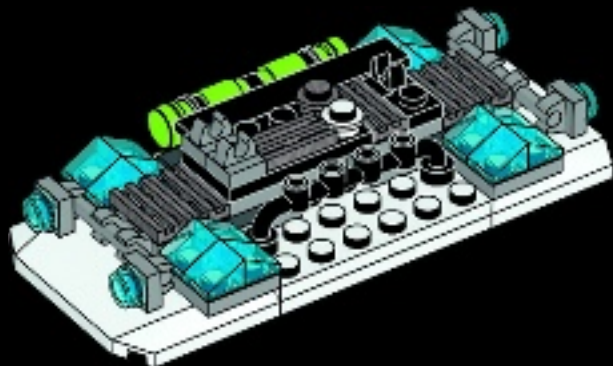

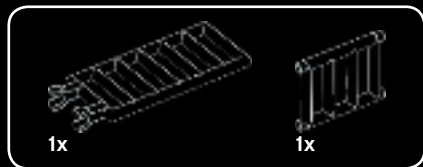

12

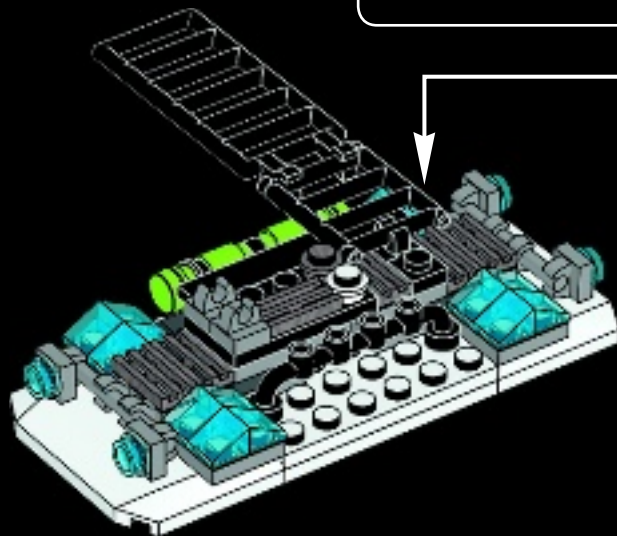
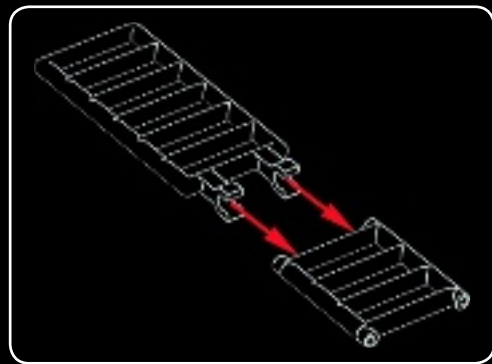





2x

13

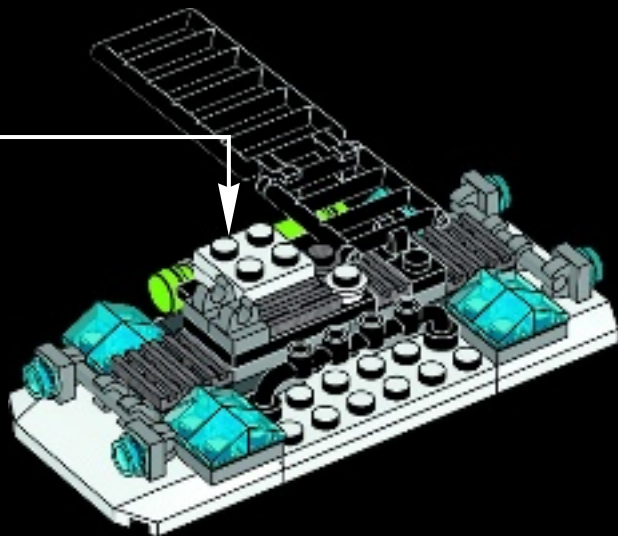
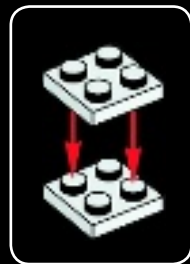



4x



4x



2x



2x

# 14

1



2



3



2x

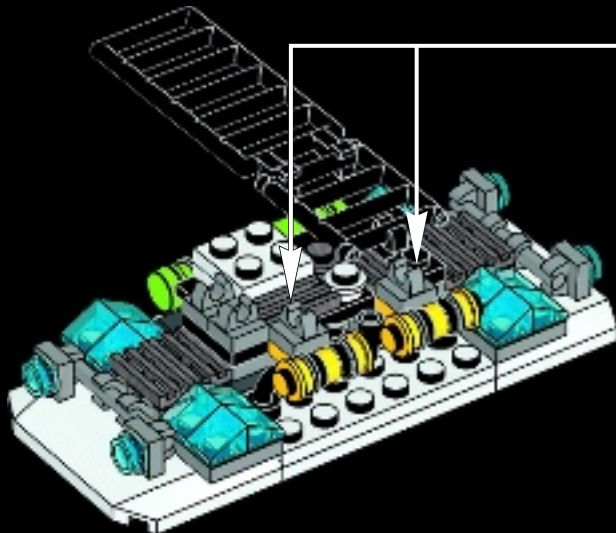

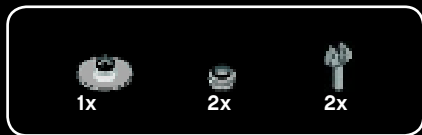

15

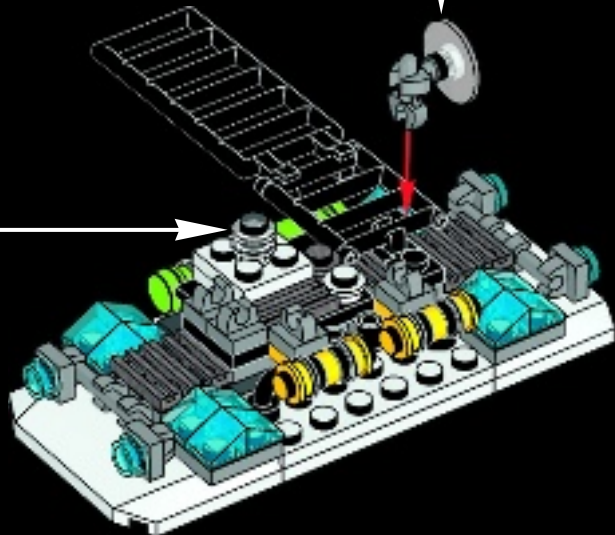
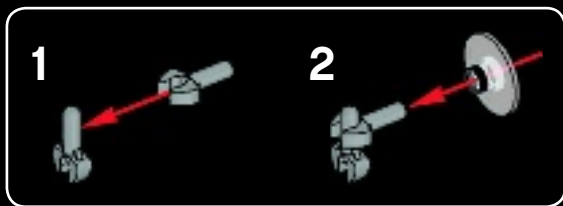



16

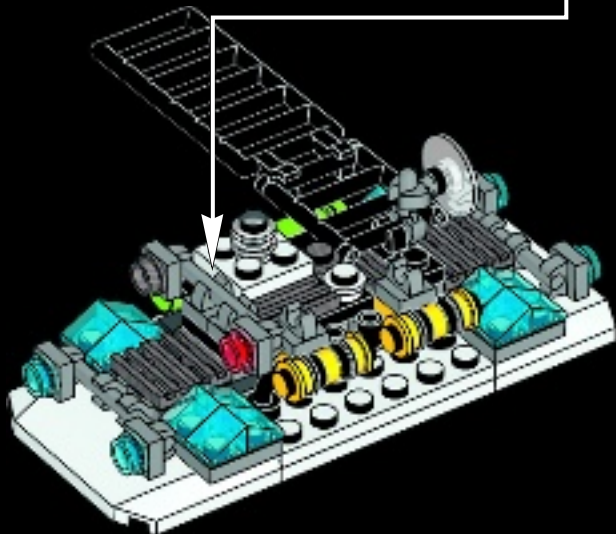
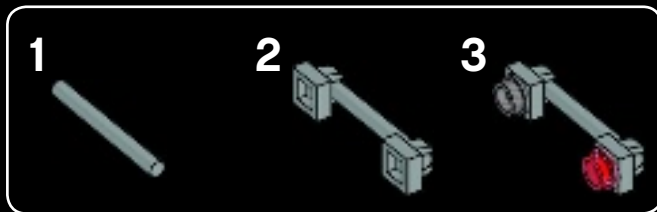



1x



1x

17

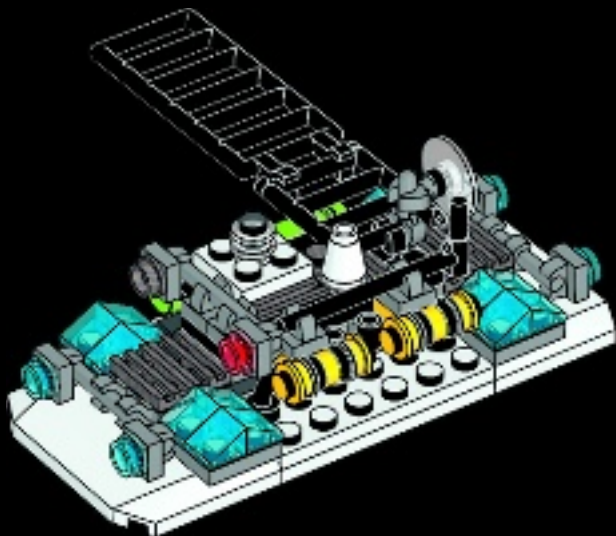



2x



1x



1x



1x



1x

# 18

1



2

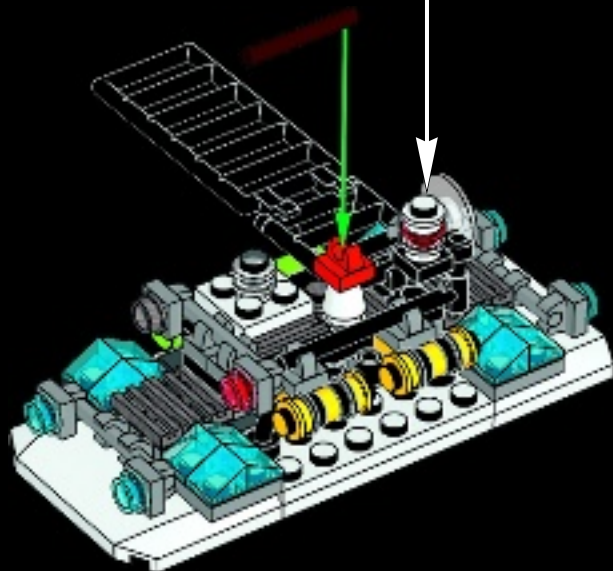

57

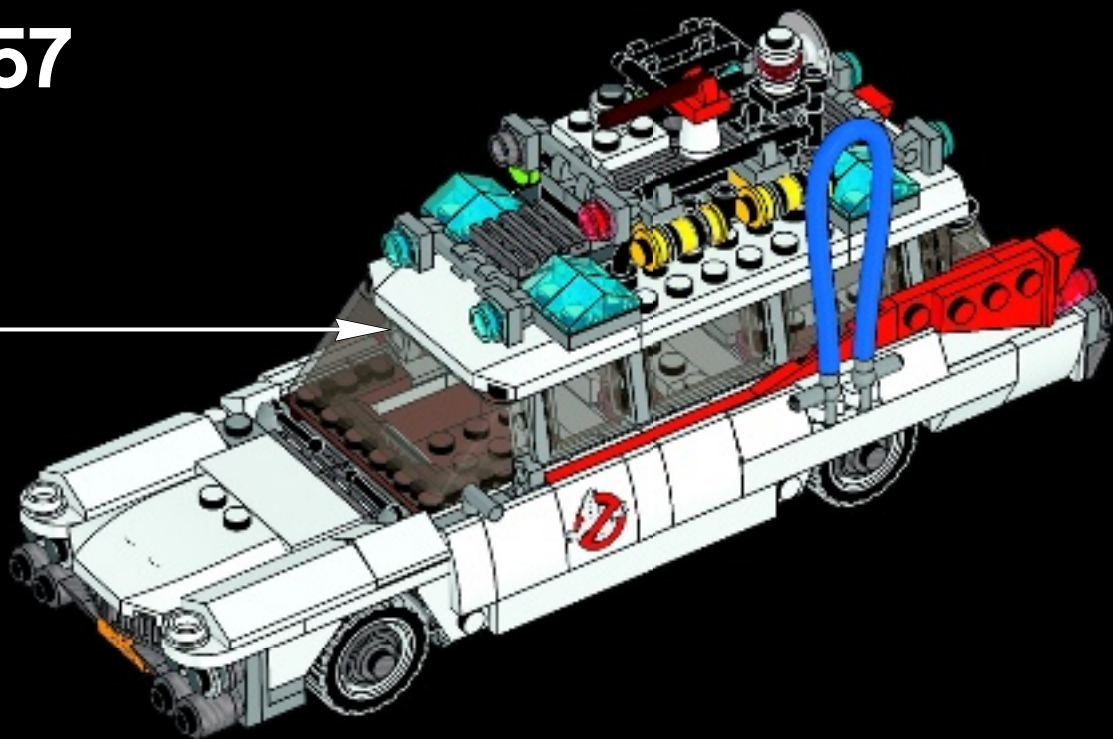

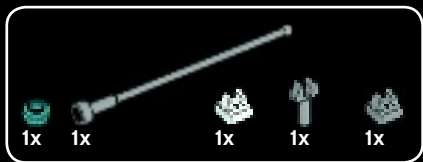

58

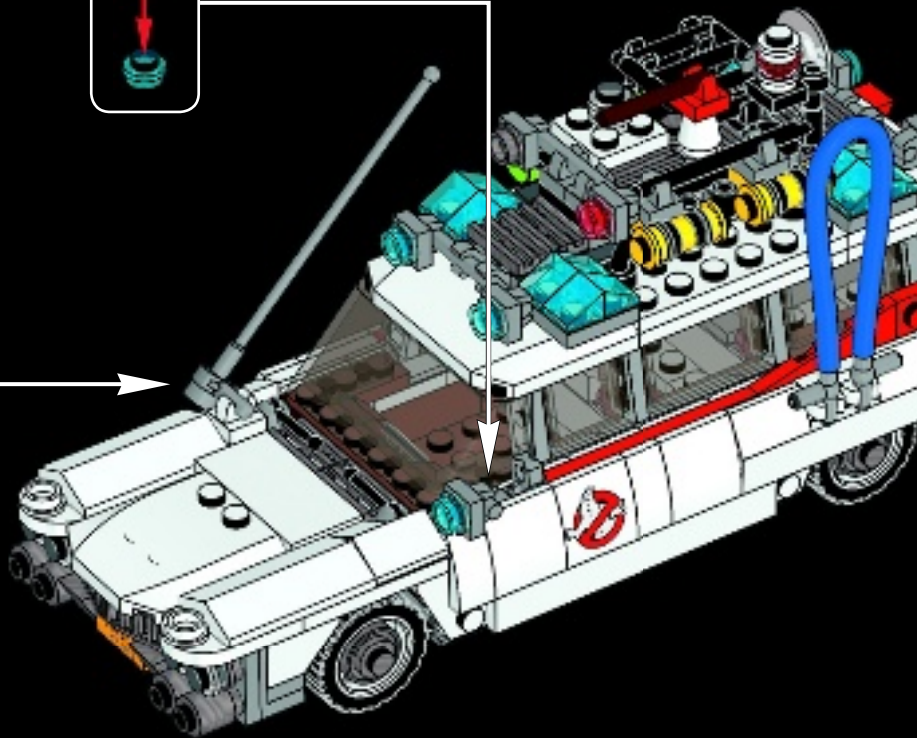
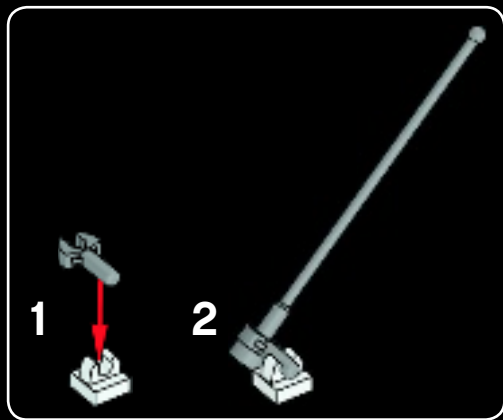



59

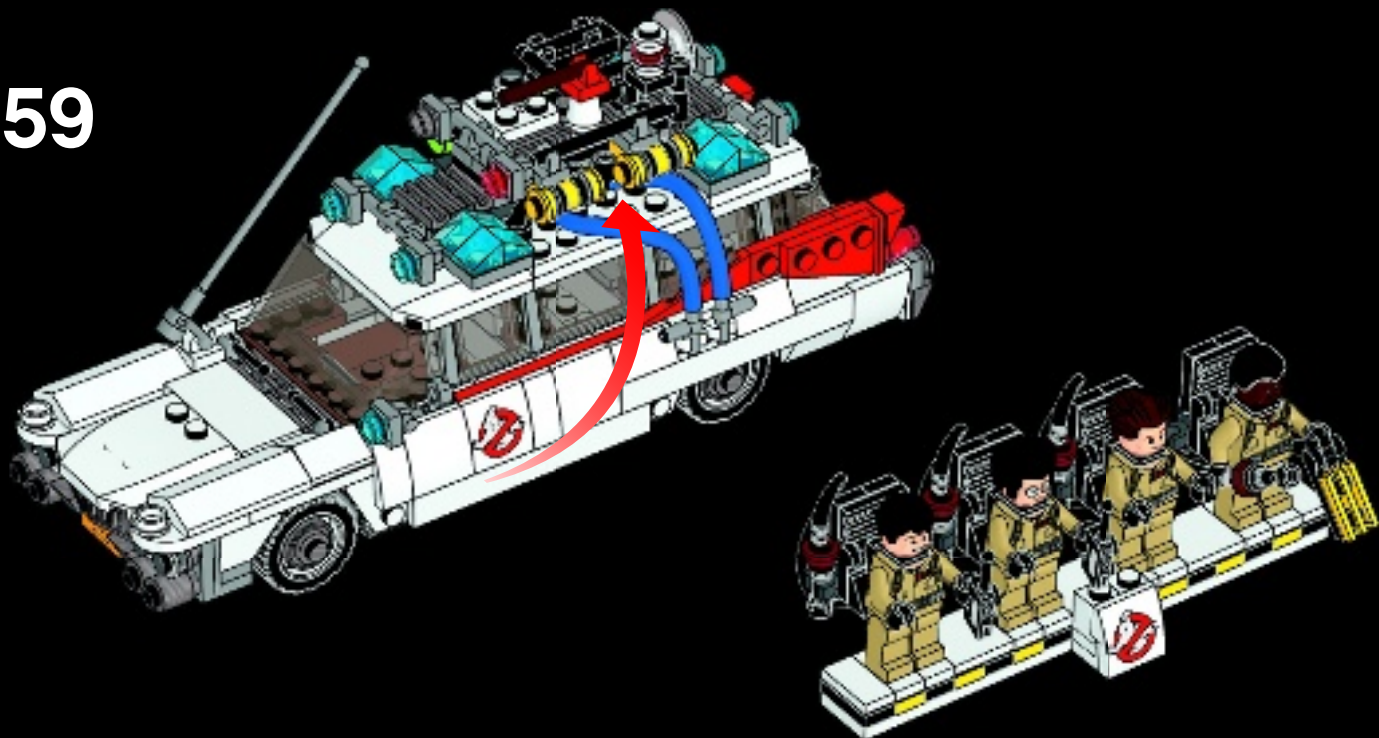

# A WORD FROM THE MODEL DESIGNERS

With the thirtieth anniversary of the blockbuster film approaching, Brent Waller, a 3D Environment Artist working in the video game industry, decided to celebrate the event by designing and building his rendition of the film's four ghost-busting characters and their iconic vehicle. Posted on the LEGO® Ideas website (then known as LEGO Cuusoo) in March 2013, it quickly gathered the 10,000 votes needed to qualify for the review process, and was declared a winning model at the start of 2014.

"The *Ectomobile* or *Ecto-1* is one of the most famous movie cars in the world, instantly recognizable even to those not familiar with the films. Decked out in all manner of ghost-catching equipment and an overabundance of sirens, I was sure it would catch the attention of any person, ghost, or demi-god in the vicinity!"



*Brent Waller*  
3D Artist

Once the model was chosen as the latest LEGO Ideas product, Marcos Bessa, a senior LEGO model designer, was given the task of transforming Brent's design into a true LEGO construction set. It was Marcos' first involvement with a LEGO Ideas project and with a background in the LEGO Fan Community himself, he enjoyed the challenge.

"Brent did a very good job with his model, but I had to ensure it had the proper stability and offered a good LEGO building experience. I kept the scale and used many of the same elements visible on the outside, which granted a similar overall look between Brent's model and the final product."



*Marcos Bessa Adam Corbally*

"It was great being a part of such an iconic LEGO product release. The first movie came out five years before I was even born, but I still watched it many times growing up and always loved it!"

For LEGO graphic designer, Adam Corbally, the biggest challenge was making each LEGO minifigure as individual as possible, while keeping it close to the reference from the films. "This was a rather challenging task due to such a small scale, but I think the final result works well."

# UN MOT DES CRÉATEURS DU MODÈLE

Le trentième anniversaire de ce film culte approchant, Brent Waller, un infographiste 3D travaillant dans le secteur du jeu vidéo, a décidé de fêter l'événement en créant et en construisant sa propre version des quatre chasseurs de fantômes du film et de leur célèbre véhicule. Publiée sur le site Web LEGO® Ideas (également appelé LEGO Cusoo) en mars 2013, son idée a rapidement obtenu les 10 000 votes nécessaires pour passer au processus de révision et fut déclaré modèle gagnant au début de 2014.

«L'Ectomobile ou Ecto-1 est l'une des plus célèbres voitures de l'histoire du cinéma, immédiatement reconnaissable même pour ceux qui ne sont pas familiers avec les films. Dotée de toutes sortes d'équipements de chasse aux fantômes et d'une surabondance de sirènes, j'étais certain qu'elle attirerait l'attention de tout individu, fantôme ou demi-dieu dans les environs !»



Brent Waller  
Artiste 3D

Une fois le modèle choisi comme produit LEGO Ideas, Marcos Bessa, un designer principal de modèles LEGO, fut chargé de transformer le concept de Brent en véritable ensemble de construction LEGO. Ceci fut la première participation de Marcos à un projet LEGO Ideas et avec son expérience de membre de la communauté de fans LEGO, il a apprécié le défi.

«Brent a fait un très bon travail avec son modèle, mais j'ai dû m'assurer qu'il avait la stabilité nécessaire et offrait une bonne expérience de construction LEGO. J'ai gardé la même échelle et utilisé de nombreux éléments similaires visibles à l'extérieur, ce qui a créé un aspect semblable entre le modèle de Brent et le produit final.»



*Marcos Bessa Adam Corbally*

«Ce fut fantastique de faire partie du lancement d'un produit LEGO aussi célèbre. Le premier film est sorti cinq ans avant ma naissance, mais je l'ai vu de nombreuses fois et je l'ai toujours adoré !»

Pour le graphiste LEGO Adam Corbally, le plus grand défi a été de rendre chaque figurine LEGO aussi individuelle et fidèle à la référence du film que possible. «C'était une tâche assez difficile en raison de la petite échelle, mais je pense que le résultat final est réussi.»

# EN PALABRAS DE LOS DISEÑADORES

Con el trigésimo aniversario de la exitosa película a la vuelta de la esquina, Brent Waller, un artista de entornos 3D perteneciente al sector de los videojuegos, decidió celebrar el evento diseñando y construyendo su propia interpretación de los cuatro *Cazafantasmas* y su popular vehículo. Tras publicarlo en el sitio web LEGO® Ideas (por aquel entonces conocido como LEGO Cusoo) en marzo de 2013, no tardó en acumular los 10.000 votos necesarios para pasar al proceso de revisión y fue declarado modelo ganador a principios de 2014.

«El *Ectomóvil*, o *Ecto-1*, es uno de los autos cinematográficos más populares del mundo e incluso las personas que no han visto las películas lo reconocen. Estaba seguro de que tantos equipos para atrapar fantasmas y tantas sirenas llamarían la atención de cualquier persona, fantasma o semidiós cercano».



*Brent Waller*  
Artista 3D

Una vez elegido el modelo para la línea LEGO Ideas, Marcos Bessa, diseñador sénior de modelos LEGO, recibió la misión de transformar el diseño de Brent en un auténtico set de construcción LEGO. Era la primera vez que Marcos participaba en un proyecto LEGO Ideas y, gracias a su gran experiencia con la comunidad de fans de LEGO, disfrutó mucho del desafío.

«Brent hizo un estupendo trabajo con su modelo, pero tenía que asegurarme de que era lo suficientemente estable y ofrecía una experiencia de construcción a la altura de LEGO. Mantuve la escala y usé muchos de los elementos que ya eran visibles por fuera para conservar el aspecto general del modelo que construyó Brent».



Marcos Bessa Adam Corbally

«Fue fantástico formar parte del lanzamiento de un producto LEGO tan popular. La primera película se estrenó cinco años antes de que yo naciera, ¡pero la vi muchas veces mientras crecía y siempre me encantó!»

Para Adam Corbally, diseñador gráfico de LEGO, el desafío más complicado fue lograr la máxima distinción entre las minifiguras LEGO, manteniendo las referencias a las películas. «Fue una tarea bastante difícil debido a la pequeña escala, pero creo que el resultado final funciona muy bien».

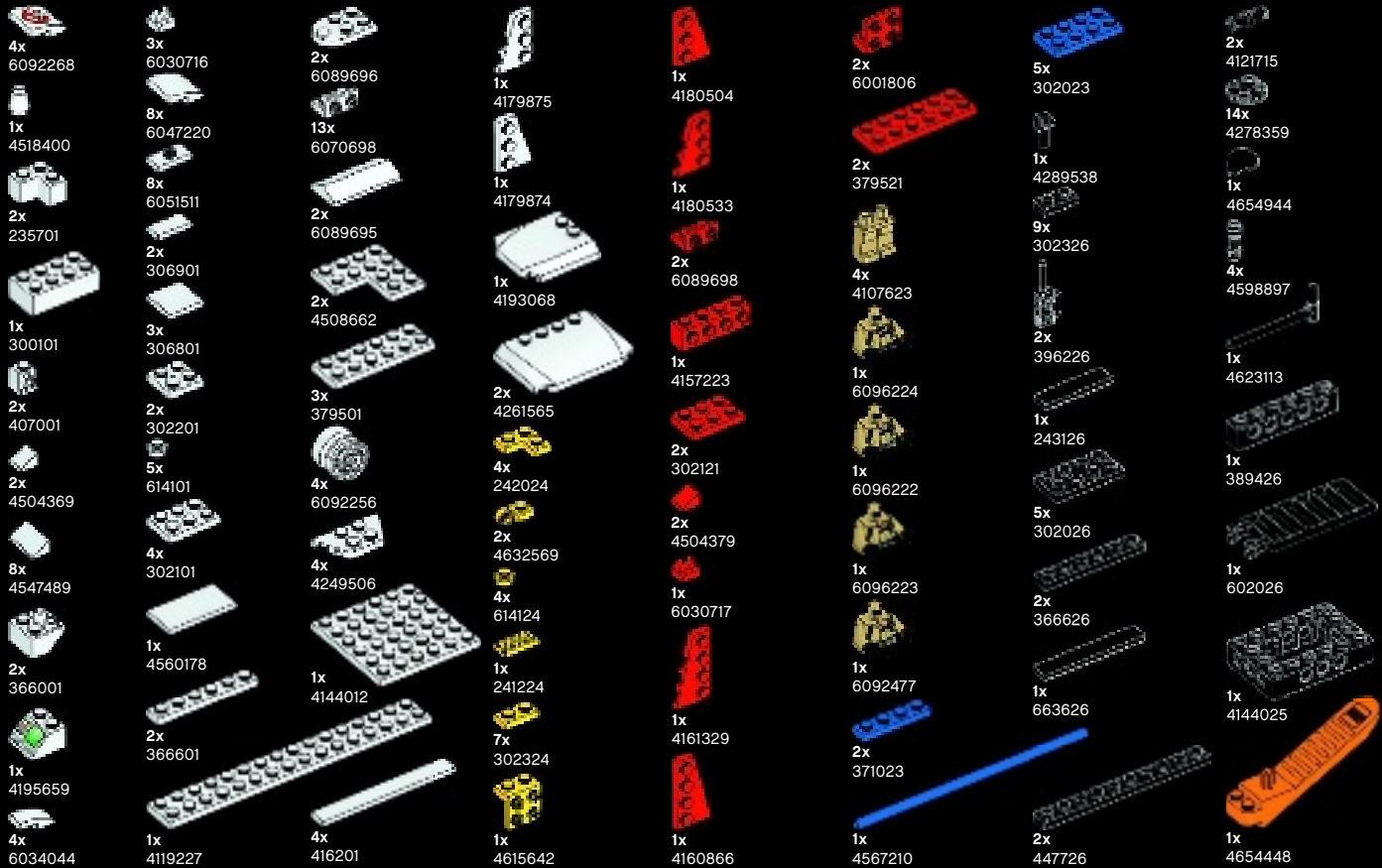

4x  
6092268

1x  
4518400

2x  
235701

1x  
300101

2x  
407001

2x  
4504369

8x  
4547489

2x  
366001

1x  
4195659

4x  
6034044

3x  
6030716

8x  
6047220

8x  
6051511

2x  
306901

3x  
306801

2x  
302201

5x  
614101

4x  
302101

1x  
4560178

2x  
366601

1x  
4119227

2x  
6089696

13x  
6070698

2x  
6089695

2x  
4508662

3x  
379501

4x  
6092256

4x  
4249506

1x  
4144012

4x  
416201

1x  
4179875

1x  
4179874

1x  
4193068

2x  
4261565

4x  
242024

2x  
4632569

4x  
614124

1x  
241224

7x  
302324

1x  
4615642

1x  
4180504

1x  
4180533

2x  
6089698

1x  
4157223

2x  
302121

2x  
4504379

1x  
6030717

1x  
4161329

1x  
4160866

2x  
6001806

2x  
379521

4x  
4107623

1x  
6096224

1x  
6096222

1x  
6096223

1x  
6092477

2x  
371023

1x  
4567210

5x  
302023

1x  
4289538

9x  
302326

2x  
396226

1x  
243126

5x  
302026

2x  
366626

1x  
663626

2x  
447726

2x  
4121715

14x  
4278359

1x  
4654944

4x  
4598897

1x  
4623113

1x  
389426

1x  
602026

1x  
4144025

1x  
4654448



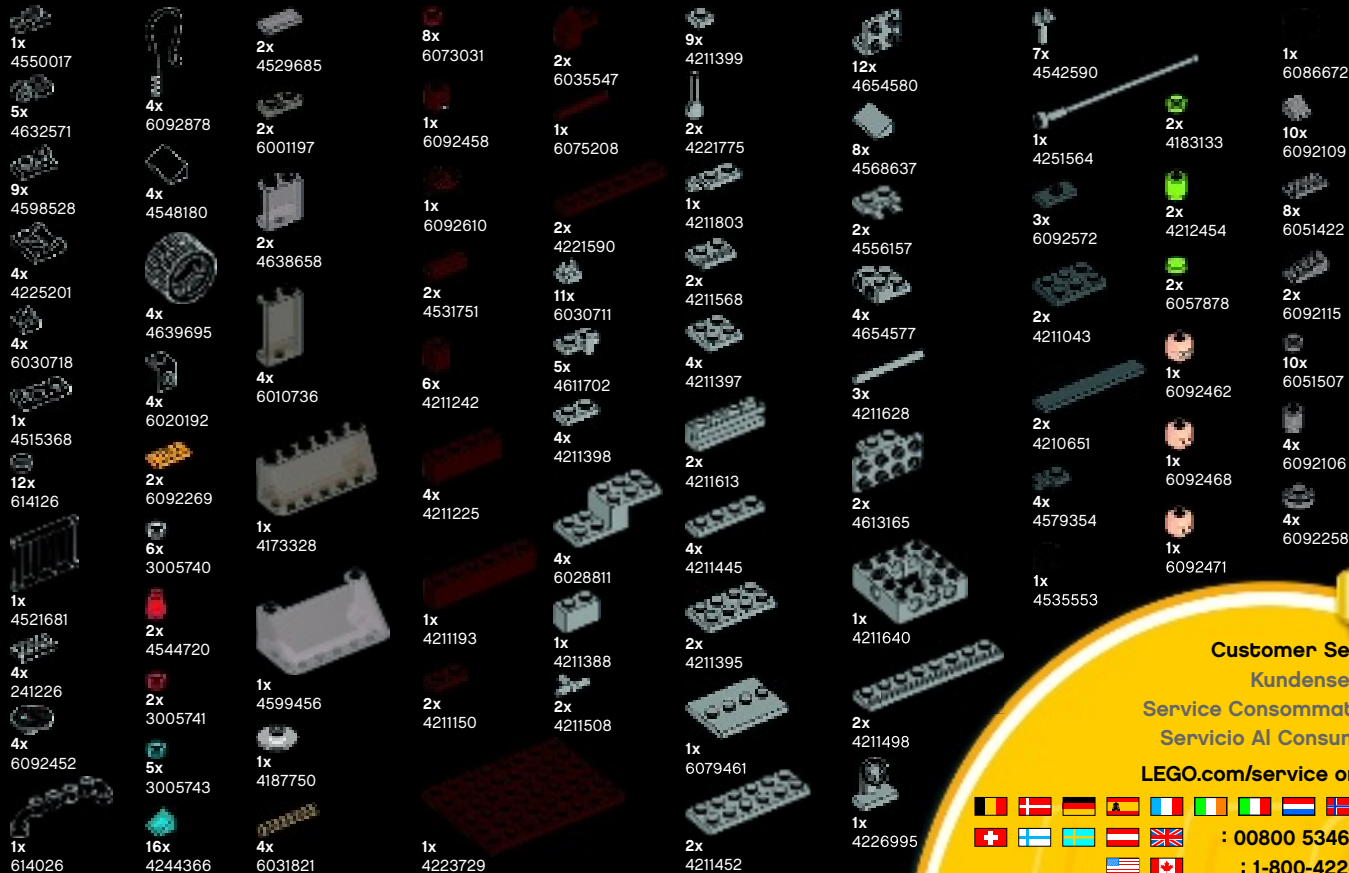

**Customer Service**  
**Kundenservice**  
**Service Consommateurs**  
**Servicio Al Consumidor**

**LEGO.com/service or dial**



**: 00800 5346 5555**

**: 1-800-422-5346**

# LEGO IDEAS: A PLAYGROUND FOR INNOVATIVE LEGO® IDEAS

Do you have an exciting idea for a LEGO® model? Then why not make it into a LEGO Ideas project? You can share your product concept on ideas.LEGO.com and see what other people think about it.

If your project gains 10,000 supporters, it will automatically qualify for the LEGO Review. This is where we take an in-depth look at the most popular projects and carefully evaluate them to discover the idea with the most potential. If your project makes it through the review, it will become an official LEGO product.

There are already over 250,000 active users and over 7000 projects on the LEGO Ideas website, and 6 products have already been launched. So take a look, sign up, and support your favorite ideas, or even better: upload your own project!



# LEGO IDEAS UN ESPACE POUR LES IDEES LEGO® NOVATRICES

As-tu une idée de modèle LEGO® passionnante ? Alors pourquoi ne pas en faire un projet LEGO Ideas ? Tu peux partager ton concept de produit sur ideas.LEGO.com et voir ce que les autres en pensent.

Si ton projet obtient l'appui de 10 000 personnes, il sera automatiquement qualifié pour un examen LEGO. Cet examen nous permet d'étudier en profondeur les projets les plus populaires et de les évaluer attentivement pour découvrir les idées ayant le plus grand potentiel. Si ton projet passe l'examen, il deviendra alors un produit LEGO officiel.

Il y a déjà 250 000 utilisateurs actifs et plus de 7000 projets sur le site Web LEGO Ideas et six produits ont déjà été lancés. Alors va regarder, inscris-toi et soutiens tes idées préférées. Ou mieux encore : télécharge ton propre projet !



[LEGO.com/ideas](https://ideas.lego.com)



**GH**OS**TBUSTERS**

# LEGO IDEAS: EL LUGAR EN EL QUE SE REUNEN LAS IDEAS LEGO®

¿Tienes una buena idea para un modelo LEGO®? ¿Por qué no convertirla en un proyecto LEGO Ideas? Puedes compartir tu idea en ideas.LEGO.com y ver lo que los demás piensan de ella.

Si tu proyecto consigue 10.000 votos, se clasificará automáticamente para la revisión de LEGO. Es entonces cuando daremos un vistazo a los proyectos más populares y los evaluaremos detenidamente para determinar qué idea tiene más potencial. Si tu proyecto supera la revisión, se convertirá en un producto LEGO oficial.

Ya hay más de 250.000 usuarios activos y más de 7.000 proyectos en el sitio web de LEGO Ideas. Además, ya se han lanzado 6 productos. Ven a dar un vistazo, regístrate y apoya tus ideas favoritas. O aún mejor: ¡envía tu propio proyecto!



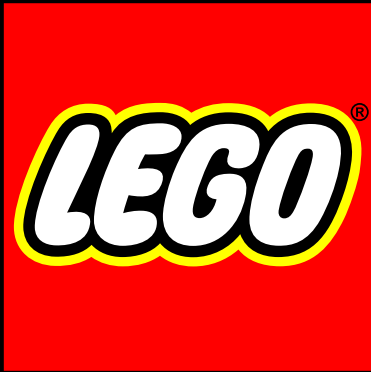

IDEAS 

The word "IDEAS" is written in a clean, white, sans-serif font. To the right of the word is the LEGO Ideas icon, which consists of a white, stylized brick shape with a small notch on its top surface.



21109



21110





# WIN!

Go to [LEGO.com/productfeedback](http://LEGO.com/productfeedback) to fill out a survey for a chance to win a cool LEGO® Product.

No purchase necessary.  
Open to all residents where not prohibited.



## LEGO.com/productfeedback

### GEWINNE!

Nimm an der Umfrage auf [LEGO.com/productfeedback](http://LEGO.com/productfeedback) teil und hab die Chance ein cooles LEGO® Produkt zu gewinnen!

Die Teilnahme am Gewinnspiel führt zu keinerlei Kaufverpflichtungen. Teilnahme in allen nicht ausgeschlossenen Ländern möglich.

 [LEGO.com](http://LEGO.com)

6115700

### WIN!

Ga naar [LEGO.com/productfeedback](http://LEGO.com/productfeedback), vul een enquêteformulier in en maak kans op een cool LEGO® product.

Geen aankoopverplichting.  
Ledereen mag deelnemen, uitgezonderd ingezetenden van landen waar een enquêteverbod geldt.

### GAGNE!

Visite [LEGO.com/productfeedback](http://LEGO.com/productfeedback) pour répondre à un questionnaire et avoir une chance de gagner un produit LEGO® très cool!

Aucune obligation d'achat.  
Ouvert à tous les résidents des pays autorisés.

### 当てよう!

[LEGO.com/productfeedback](http://LEGO.com/productfeedback) にアクセスして、アンケートにご記入ください。当選者にはレゴ®製品を差し上げます。

お買い上げの必要はありません。  
禁止されていない限り、すべての皆様にご利用いただけます。

LEGO and the LEGO logo are trademarks of the/son des marques de commerce du/son marcas registradas de LEGO Group. ©2014 The LEGO Group.

© 2014 Columbia Pictures Industries, Inc. All rights reserved/Tous droits réservés/Todos los derechos reservados.