

---

# TITANIC

BUCH 2

---

# DAS LUXURIÖSESTE PASSAGIERSCHIFF DER WELT

Als Inbegriff von Eleganz, Komfort und Luxus war die *Titanic* in erster Linie als schwimmendes Hotel gedacht, das quasi nebenbei auch noch als Passagierschiff fungierte. Die 833 Passagiere in den prachtvollen Kabinen der ersten Klasse kamen in den Genuss diverser Annehmlichkeiten. Neben exquisiten Restaurants lockten auch ein Gymnastikraum, eine Squashanlage, ein Schwimmbecken und Bibliotheken. Eine der aufwendigsten Räumlichkeiten war das geschwungene *große Treppenhaus* mit Wandtäfelungen aus Eichenholz, das sieben Schiffdecks hinunterreichte.



↑ Das Achtertreppehaus der Ersten Klasse führte zum À-la-Carte-Restaurant.

→ Speisekarte der 2. Klasse vom 14. April 1912, dem Tag, an dem die Titanic mit dem Eisberg kollidierte, der sie untergehen ließ.

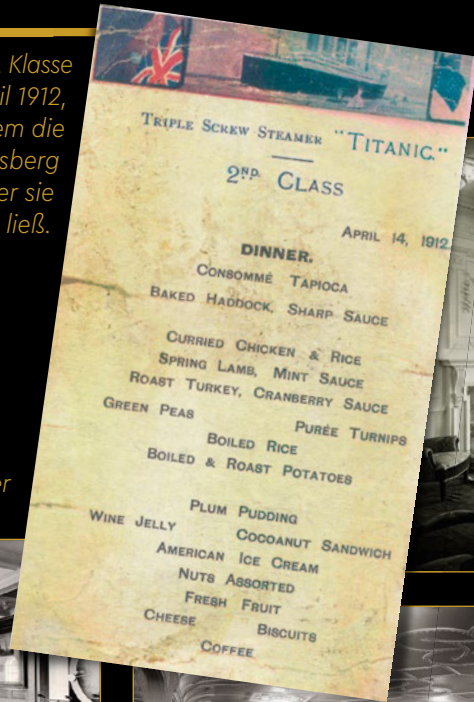

↓ Lesesalon auf dem oberen Promenadendeck.



↓ Die Erste-Klasse-Lounge.



↓ Gymnastikraum der 1. Klasse.



↑ Hauptspeisesaal.



↑ Café Parisien, ein Nebenraum des Erste-Klasse-Restaurants.



↑ Die prachtvolle Eleganz der Erste-Klasse-Suite B57.

# BAU DER TITANIC

Was ursprünglich als Konzeptmodell im Rahmen einer freien „Kreativsession“ für LEGO® Designer begann, sollte sich zum bisher größten LEGO Set entwickeln.

Die imposante Größe war dabei nicht das eigentliche Ziel. Der Maßstab wuchs einfach mit den vielen aufwendigen Details, die das Designteam unbedingt in dem Modell unterbringen wollte. Der erfahrene LEGO Designer Mike Psiaki musste unter anderem Dampfmaschinen mit beweglichen Kolben mithilfe von LEGO Technic Elementen nachbilden. Nachdem der erste Entwurf fertig war, verbrachte das Team eine ganze Woche damit, unterschiedliche Versionen des Modells zu bauen. So ließ sich feststellen, was verstärkt oder vereinfacht werden musste.



↑ Einige Mitglieder des LEGO® Modellteams (von links nach rechts): Senior Model Coach Torben Kidde Skov, Design Master Mike Psiaki und Senior Building Instruction Specialist Martin Højen Holm Buk



[LEGO.com/brickseparator](https://www.lego.com/brickseparator)

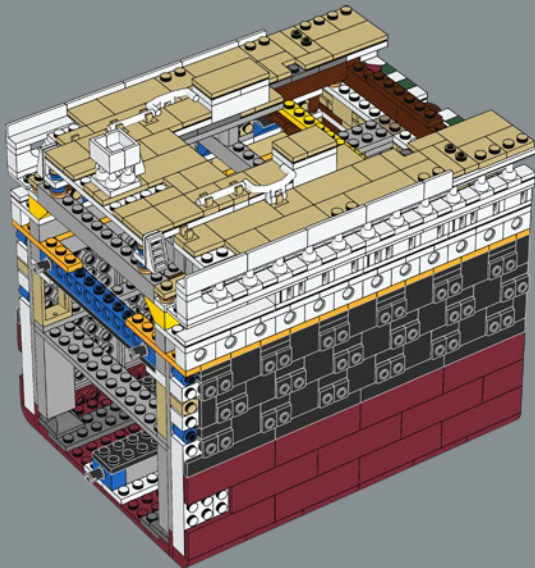
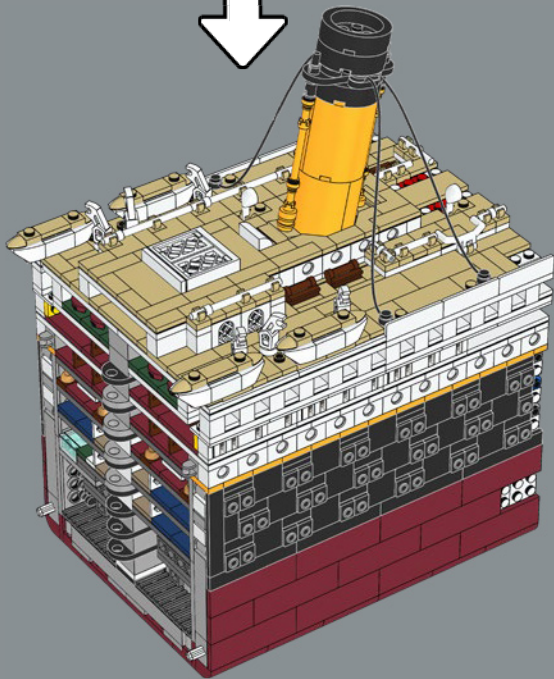

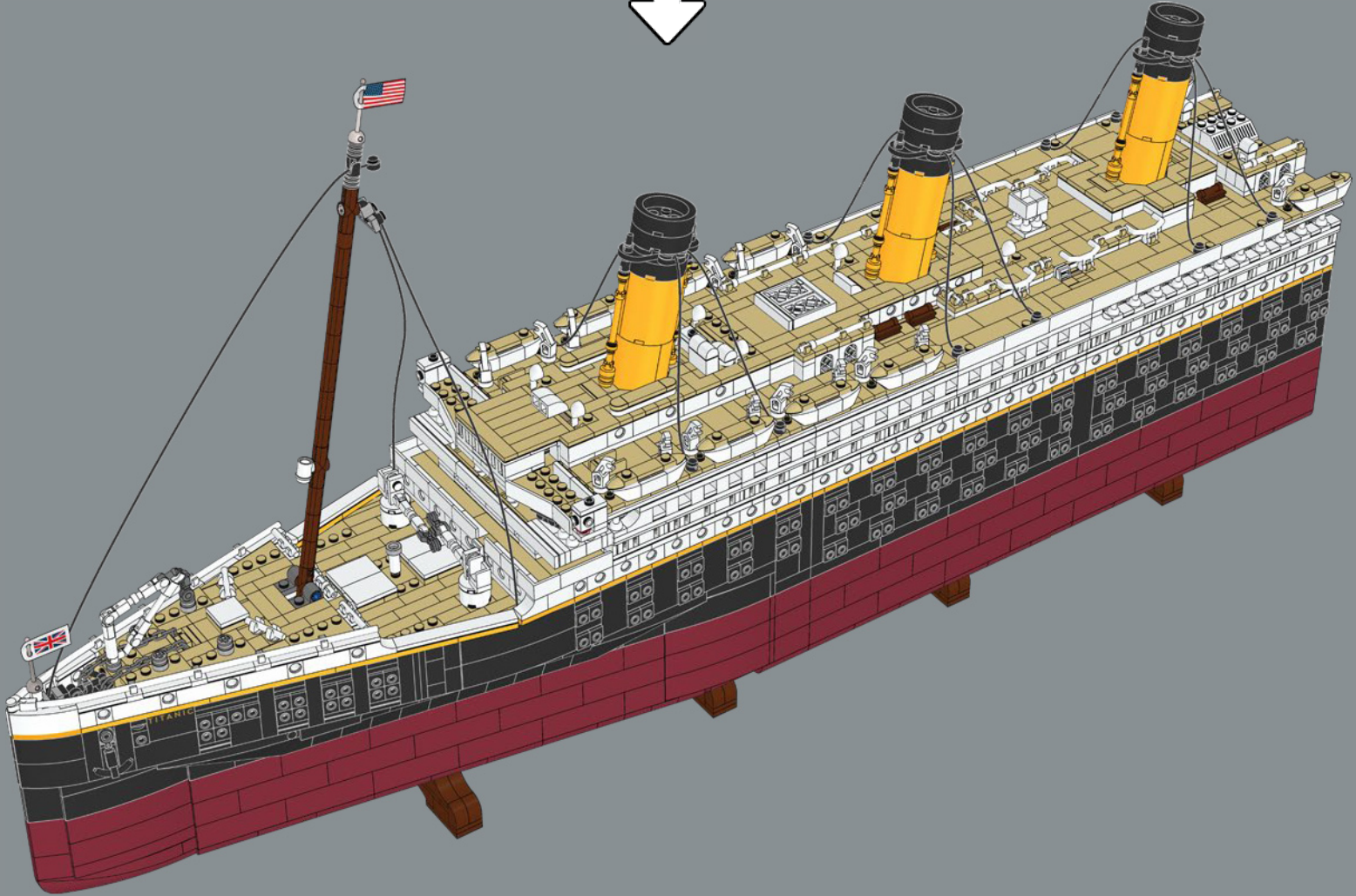
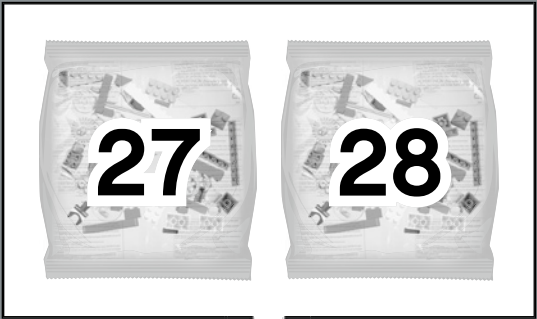

↓ Hier wird auch die zweite Hälfte des Verriegelungsmechanismus gebaut, der die 3 Hauptabschnitte des Schiffs zusammenhält.

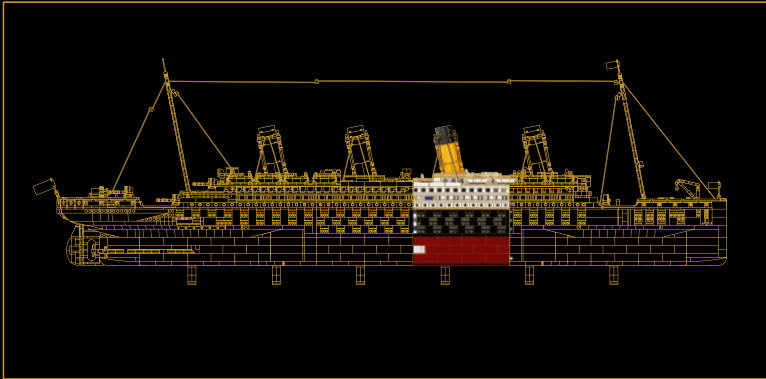

### ABSCHNITT 3:

# SCHORNSTEIN & HAUPTKABINEN

In diesem Abschnitt baust du einen weiteren Querschnitt des Schiffs, der unter anderem die Kohlebunker in den untersten Decks sowie zahlreiche Kabinen der diversen Klassen umfasst. Der Aufbau in diesem Abschnitt beinhaltet die Anfänge der Promenadendecks, das Oberlicht für das große Treppenhaus und den zweiten Schornstein.





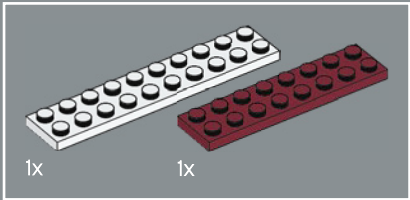
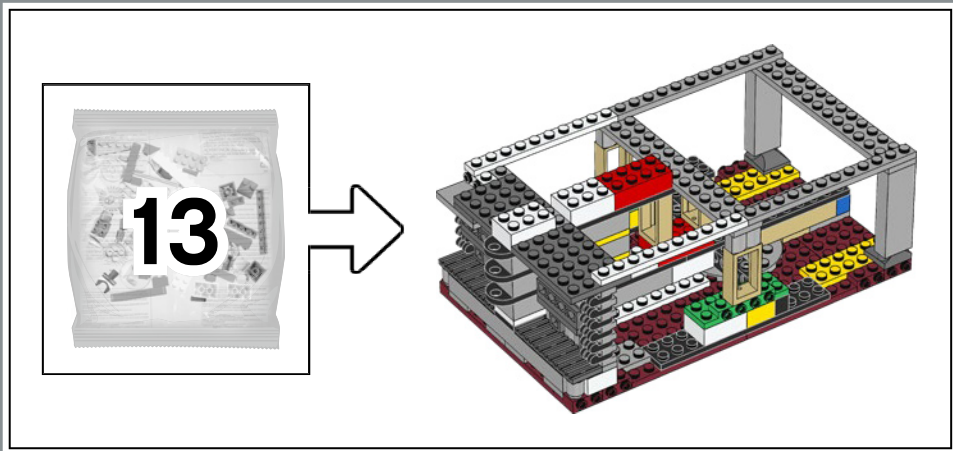

1

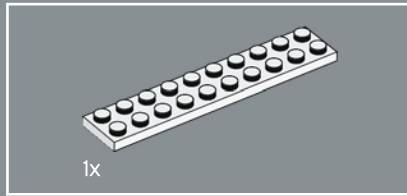
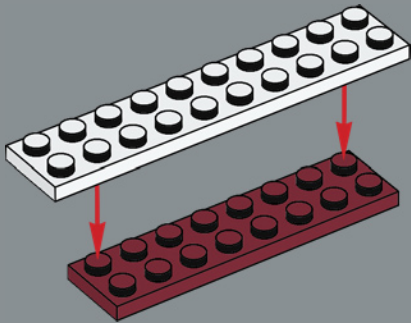

2

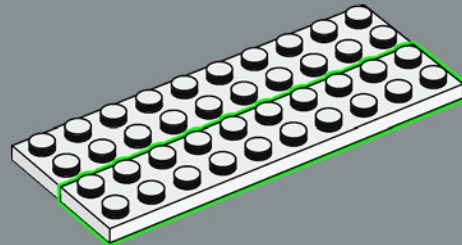

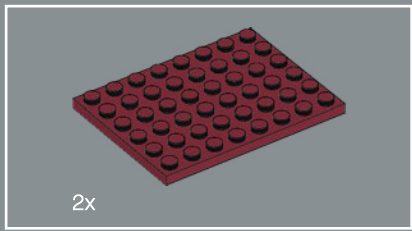

3

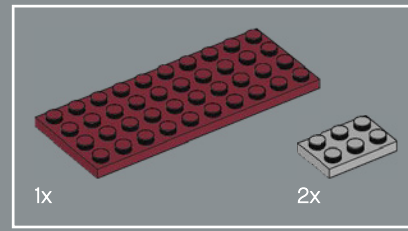
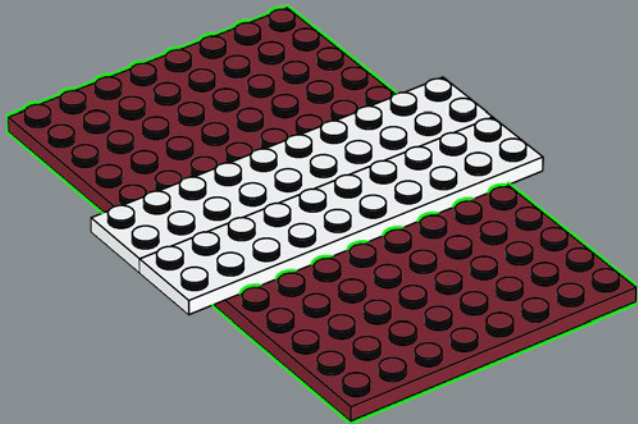

4

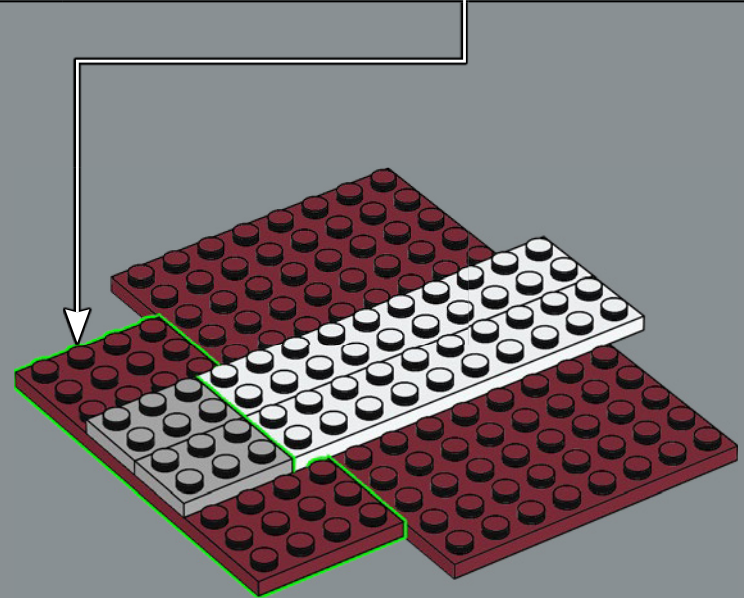
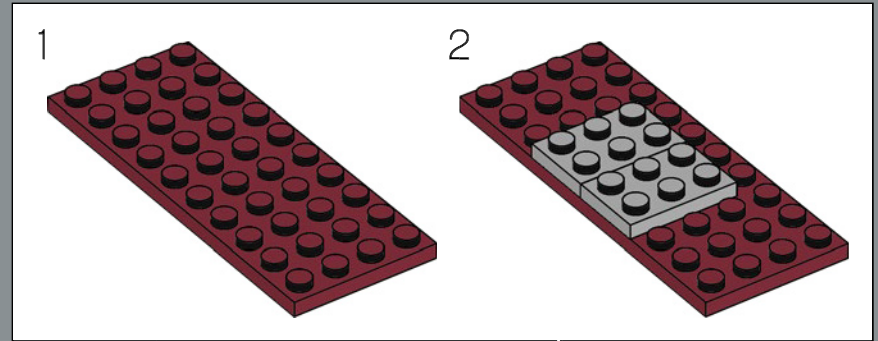

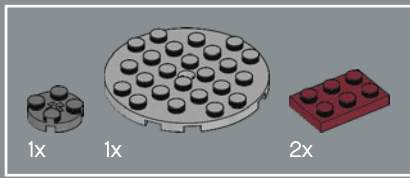

5

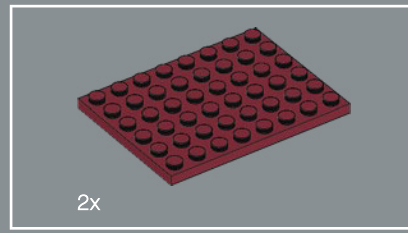
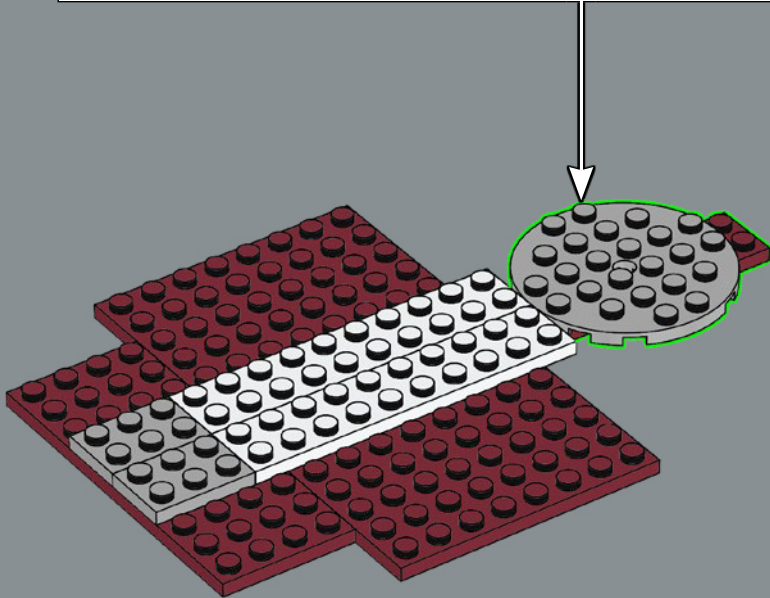
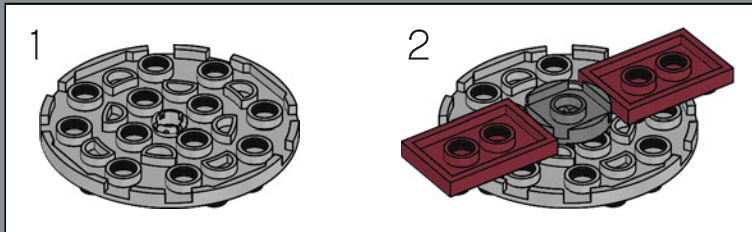

6

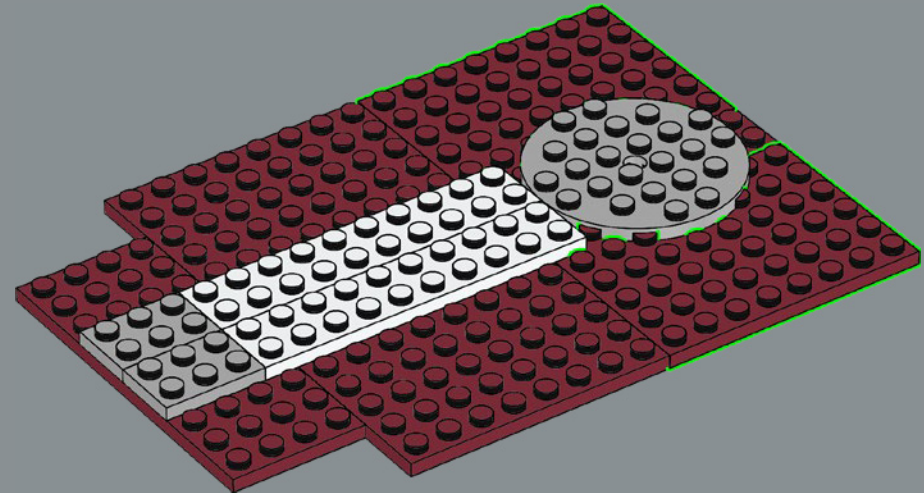

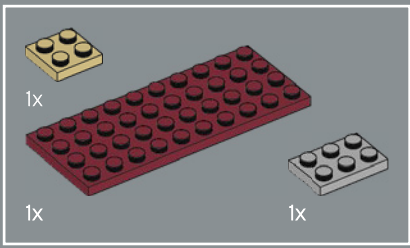

7

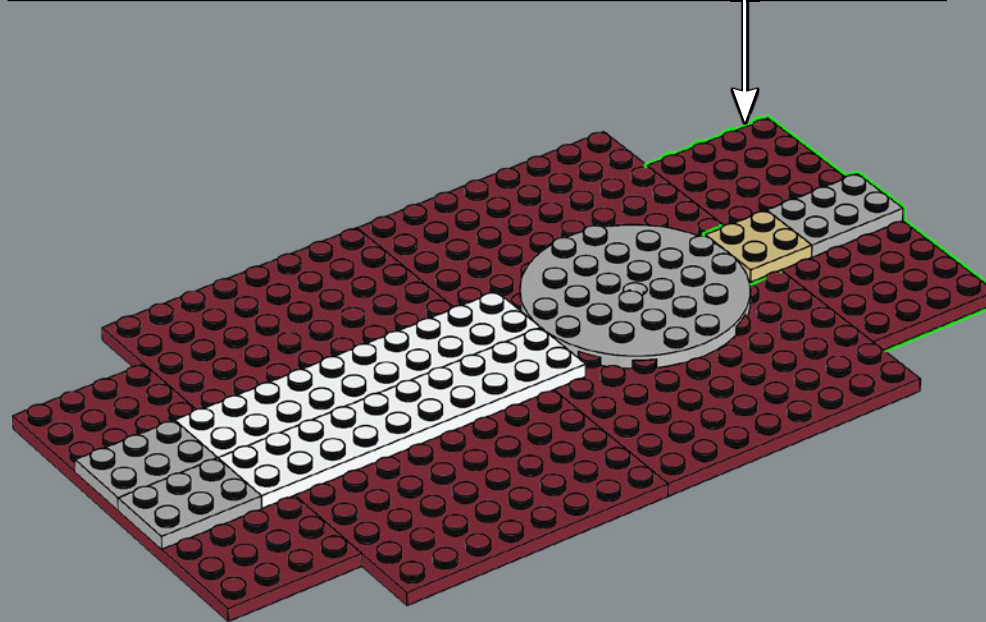
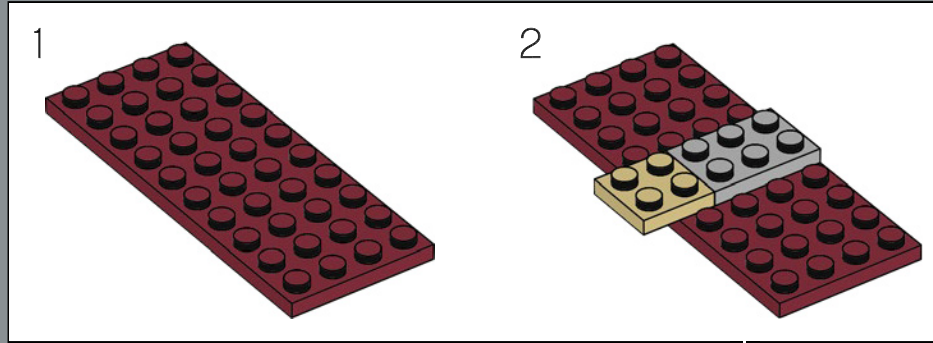

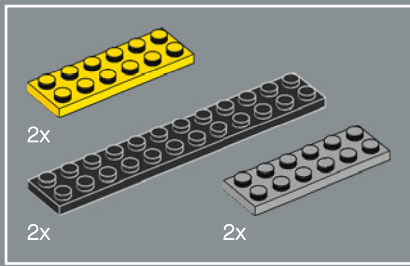

8

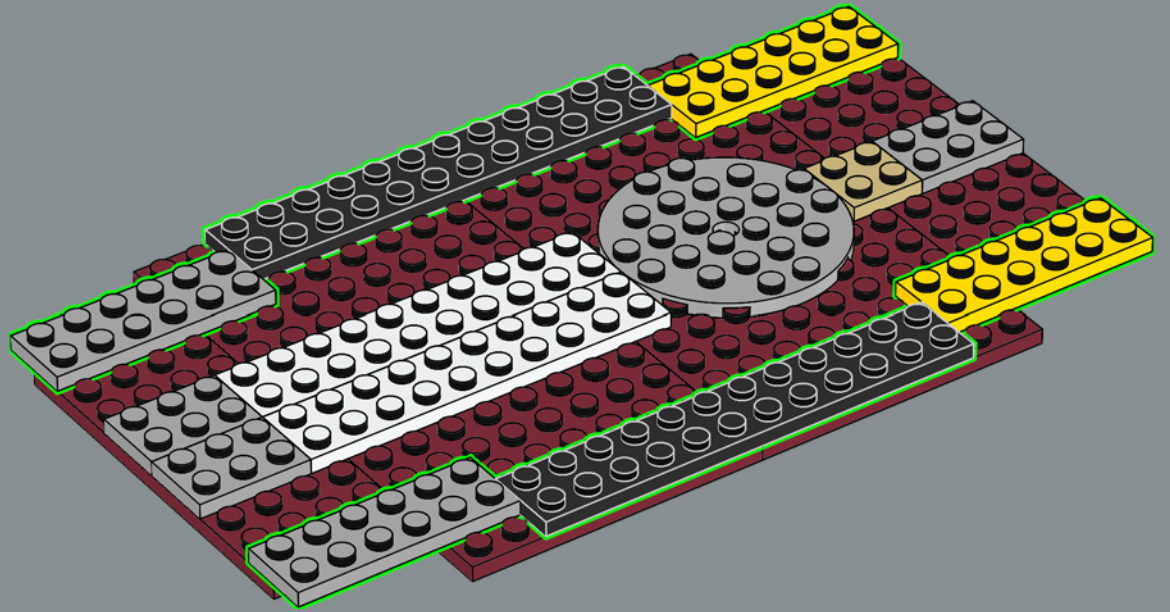

9

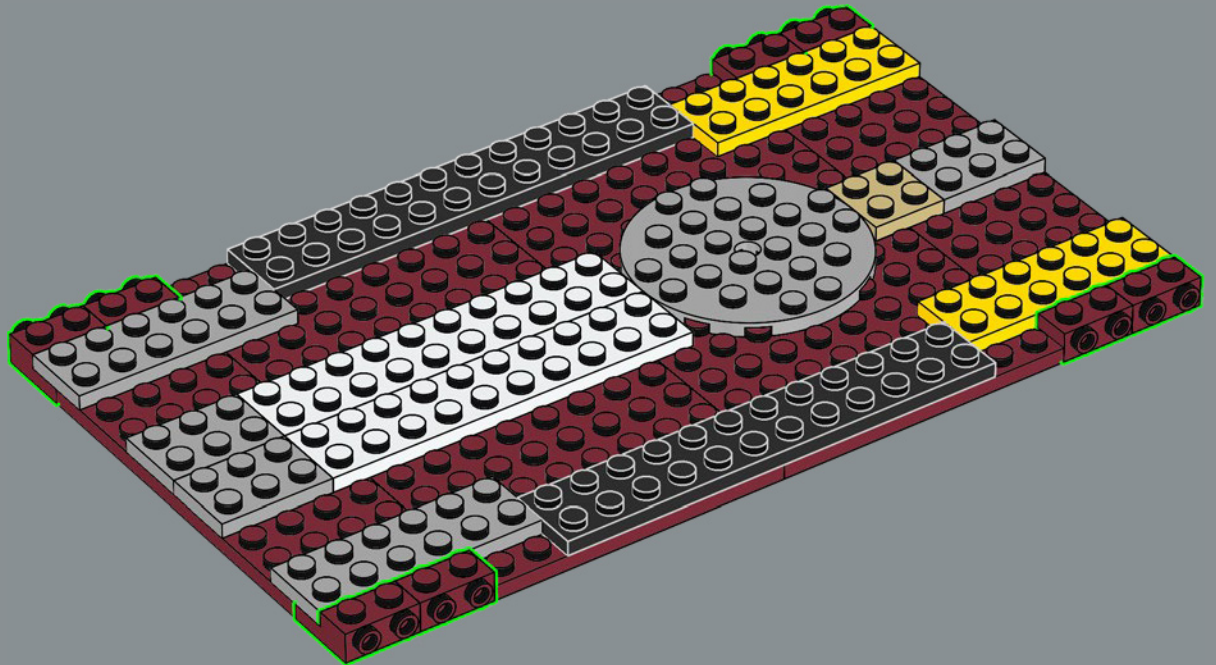

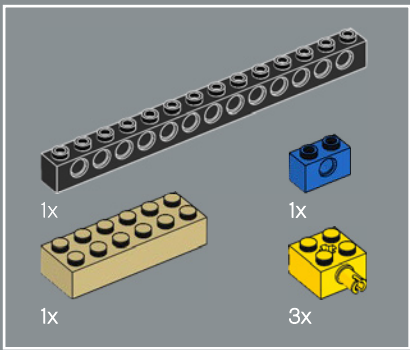

10

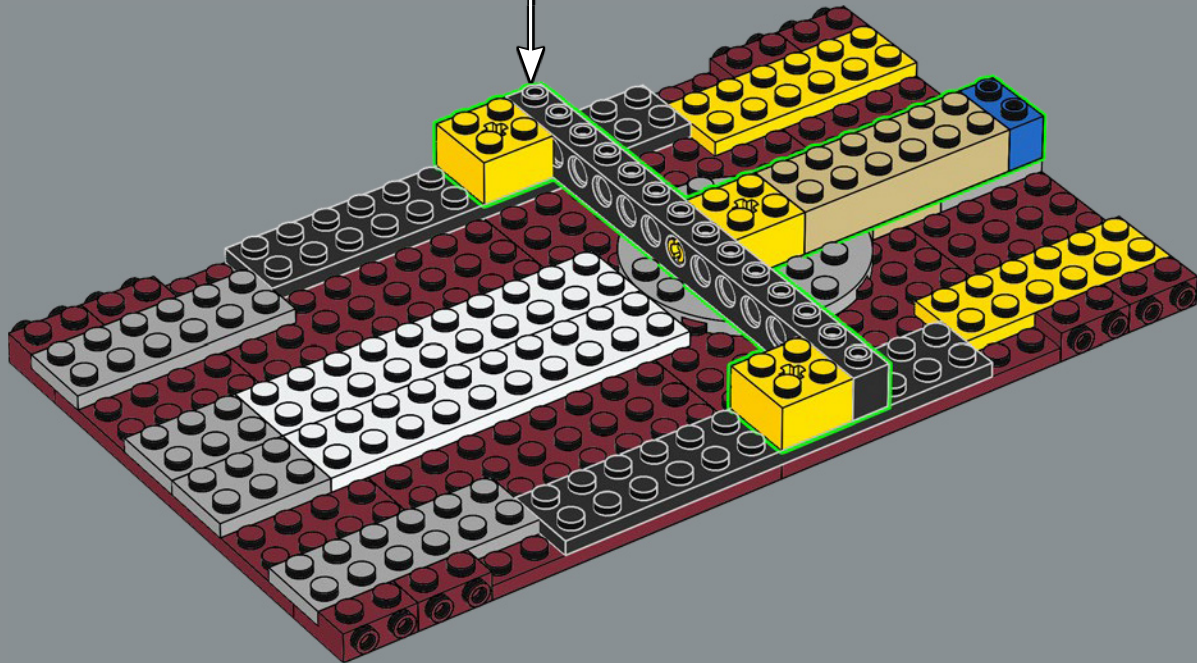
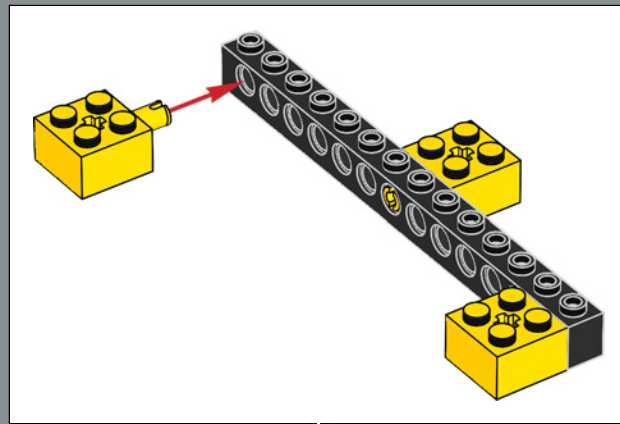

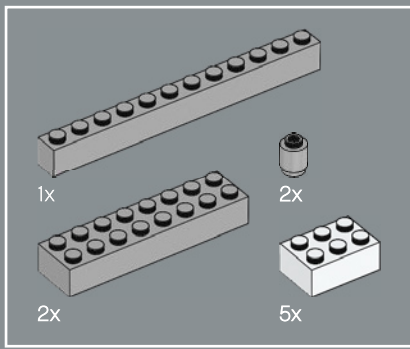

11

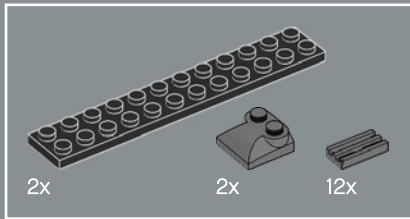
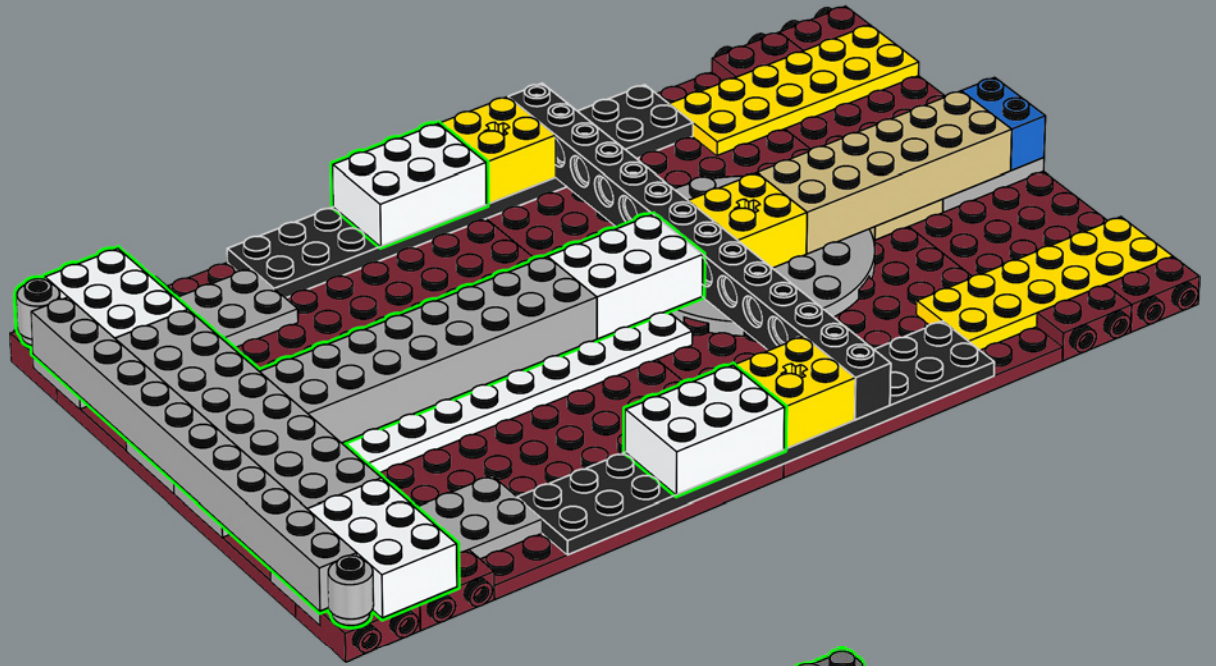

12

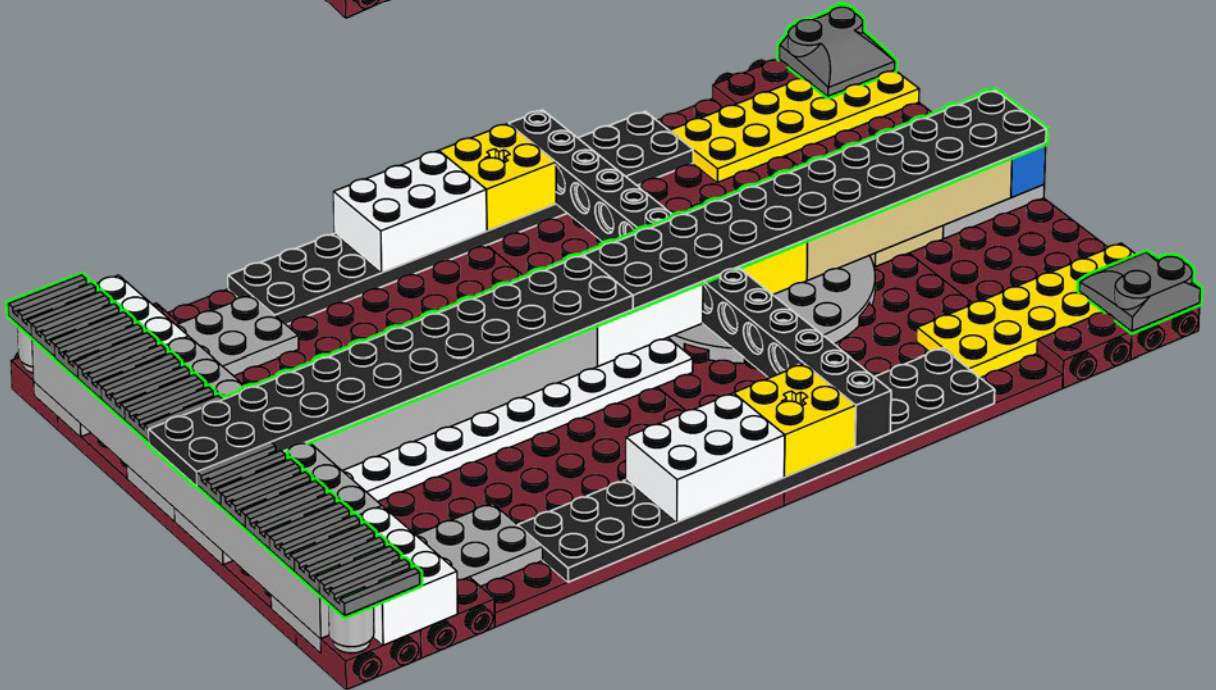

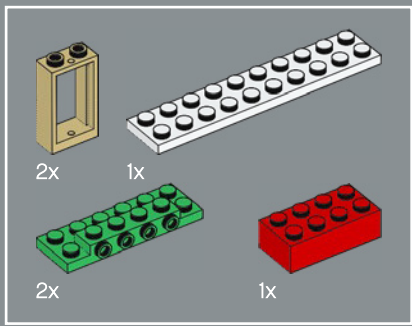

13

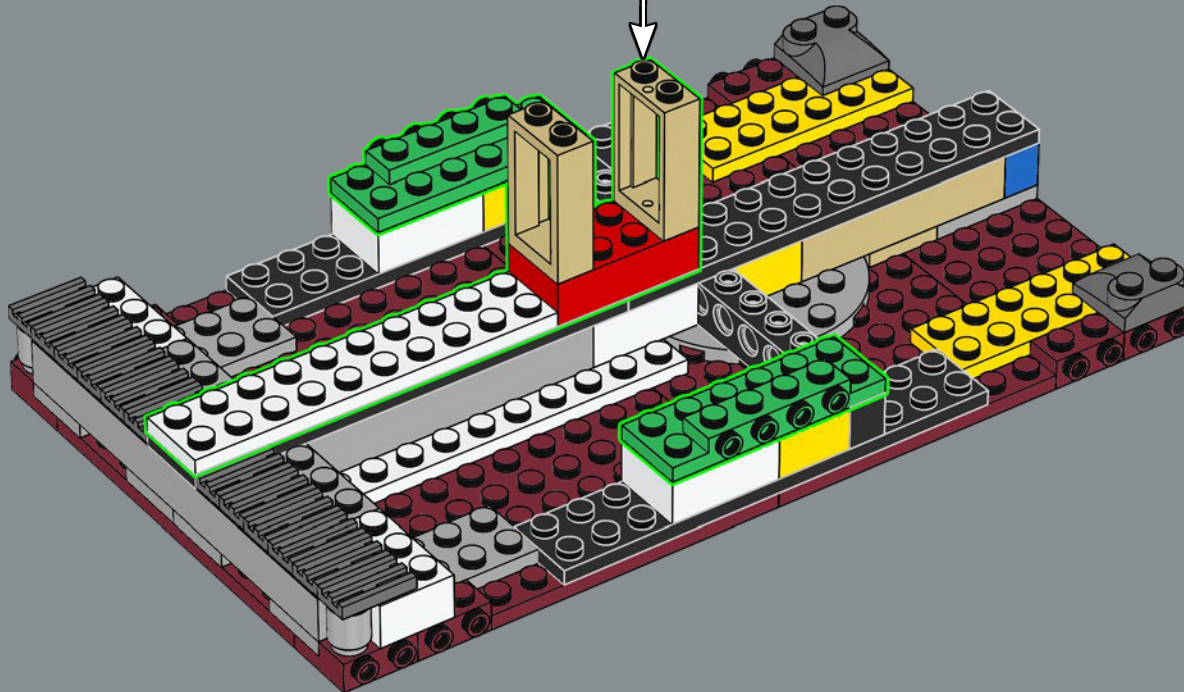
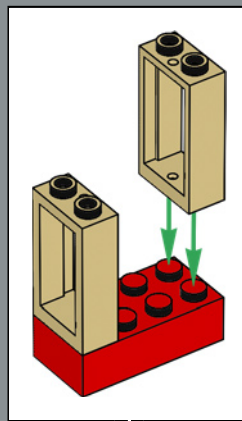



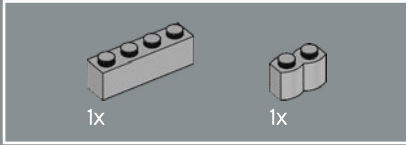
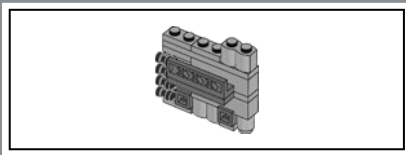

14

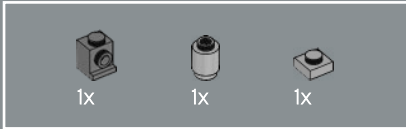
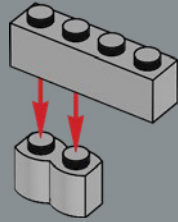

15

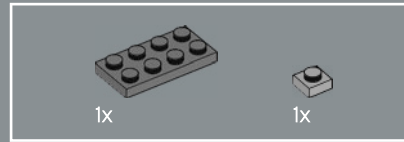
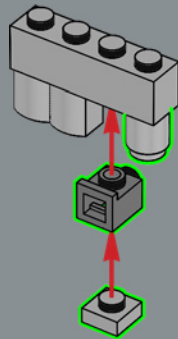

16

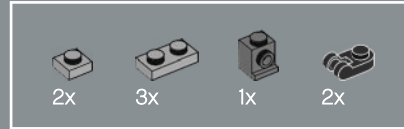
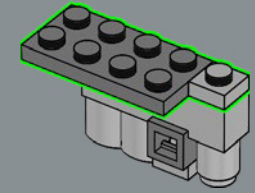

17

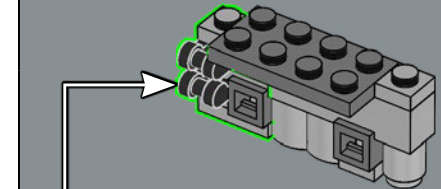
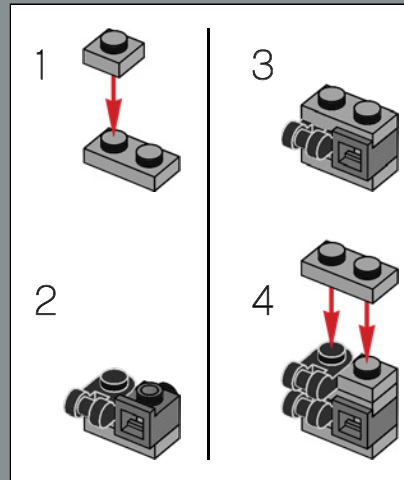

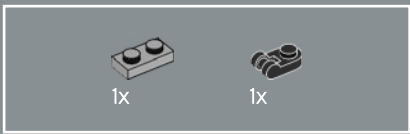

18

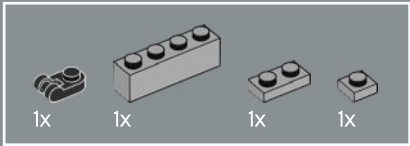
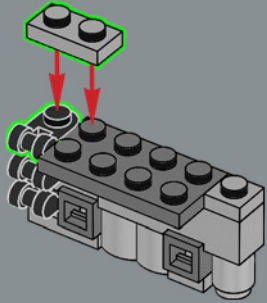

19

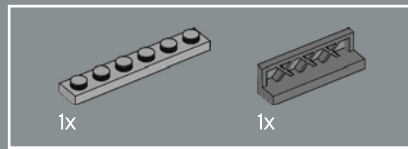
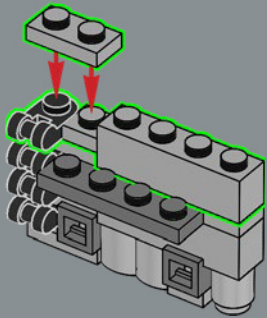

20

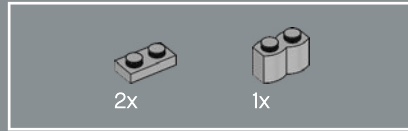
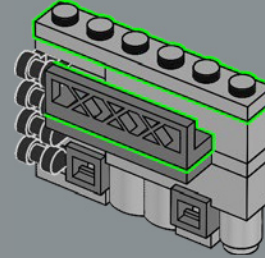

21

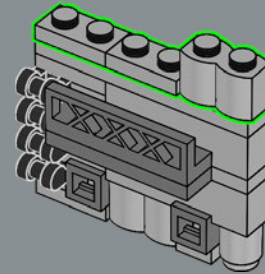

22

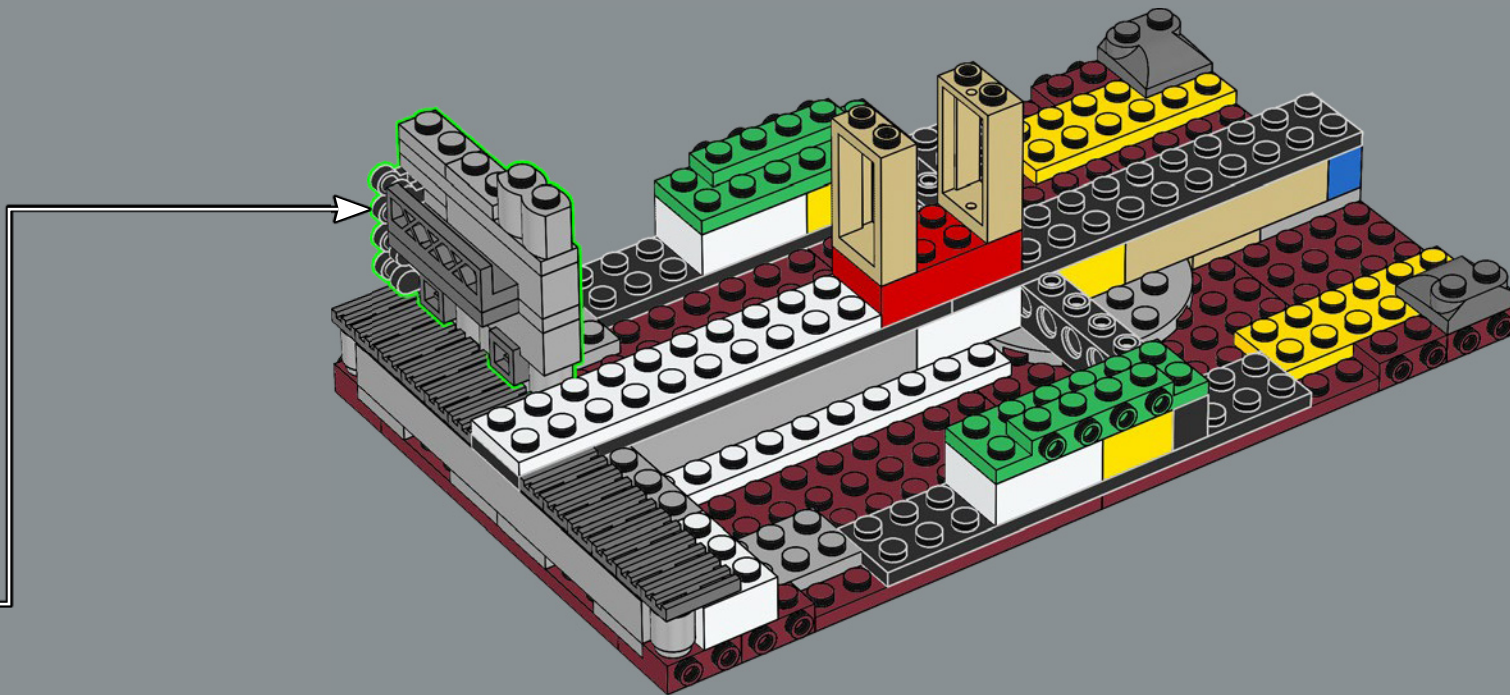

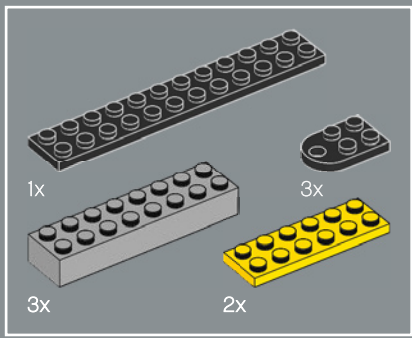

23

1

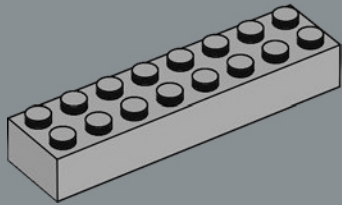

2

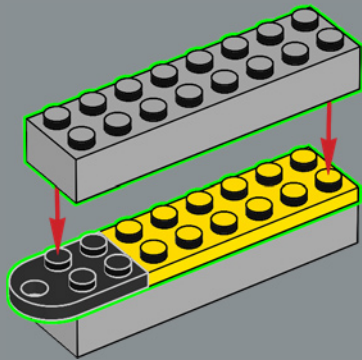

3

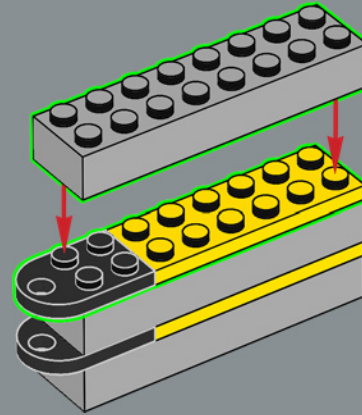

4

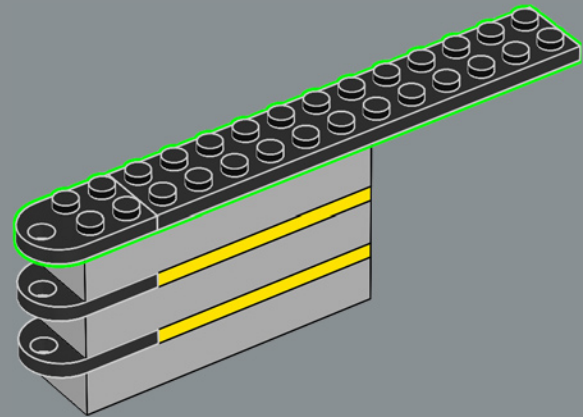

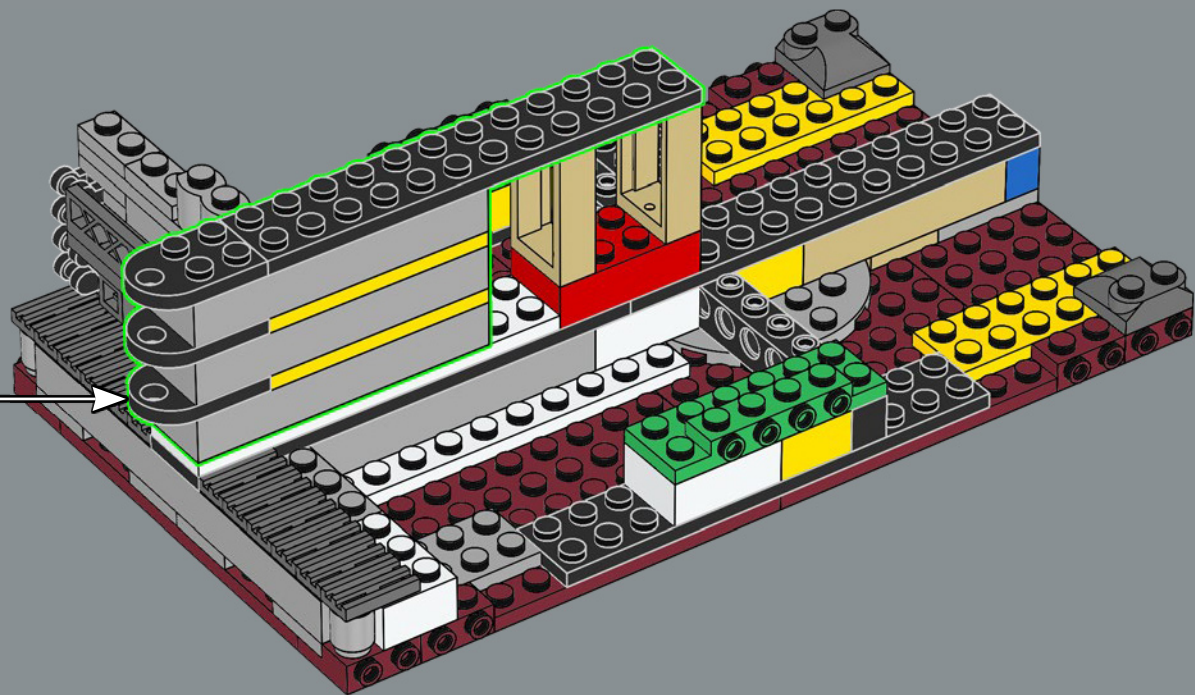

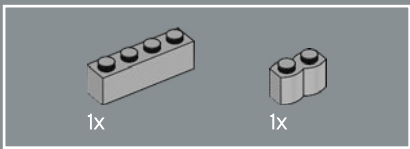

24

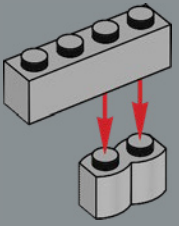

25

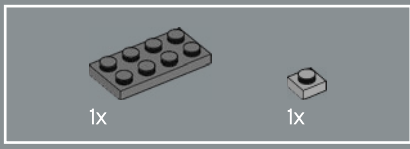
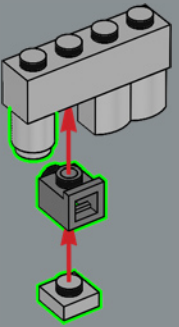

26

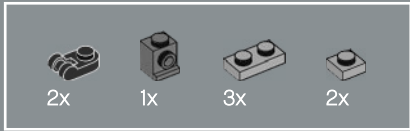
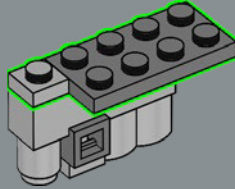

27

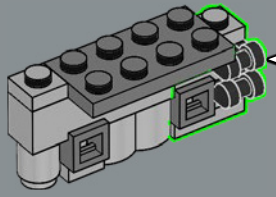
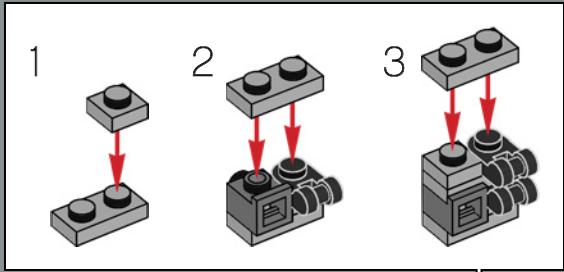

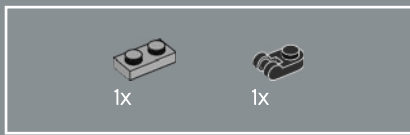

28

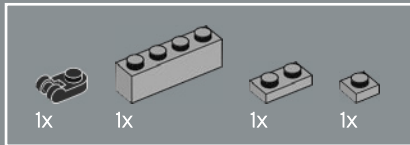
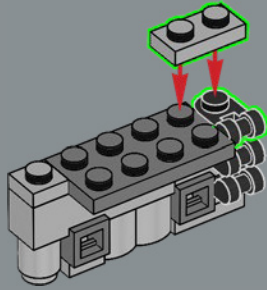

29

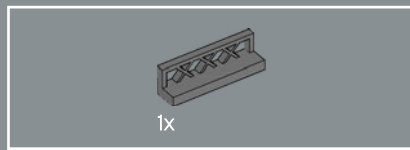
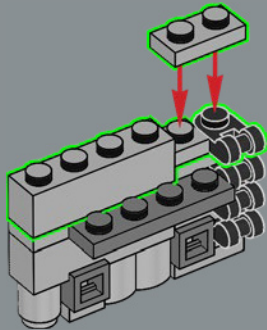

30

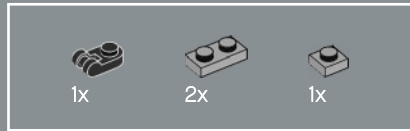
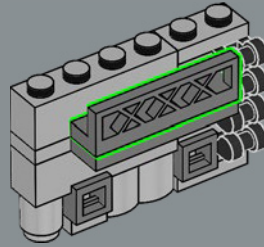

31

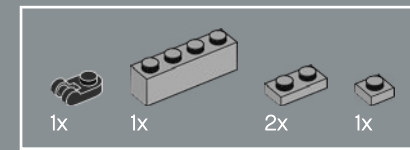
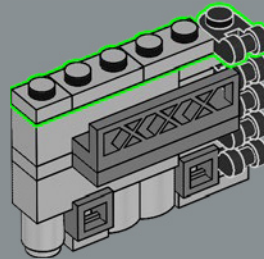

32

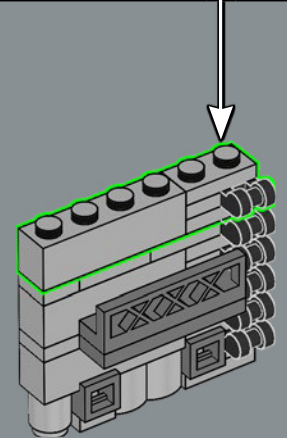
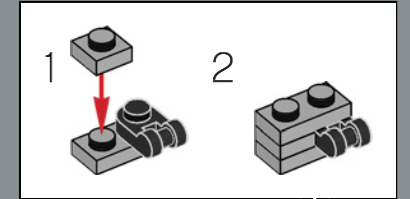

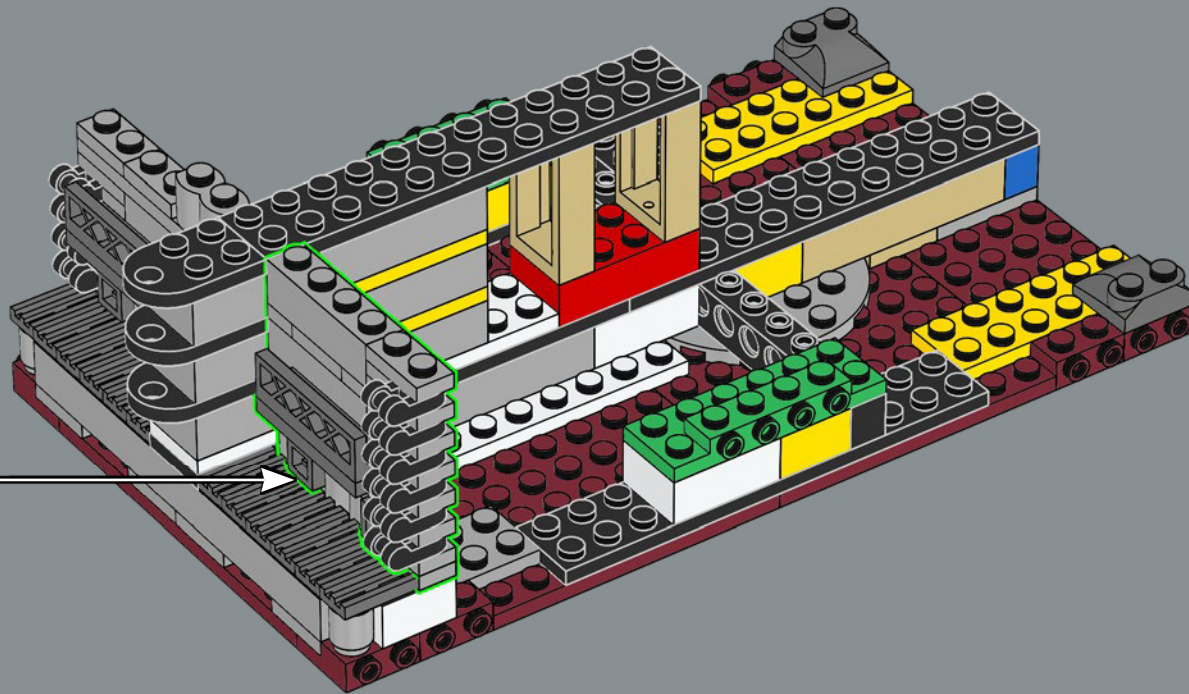



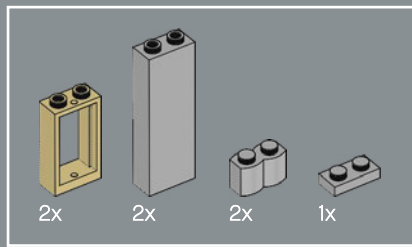

34

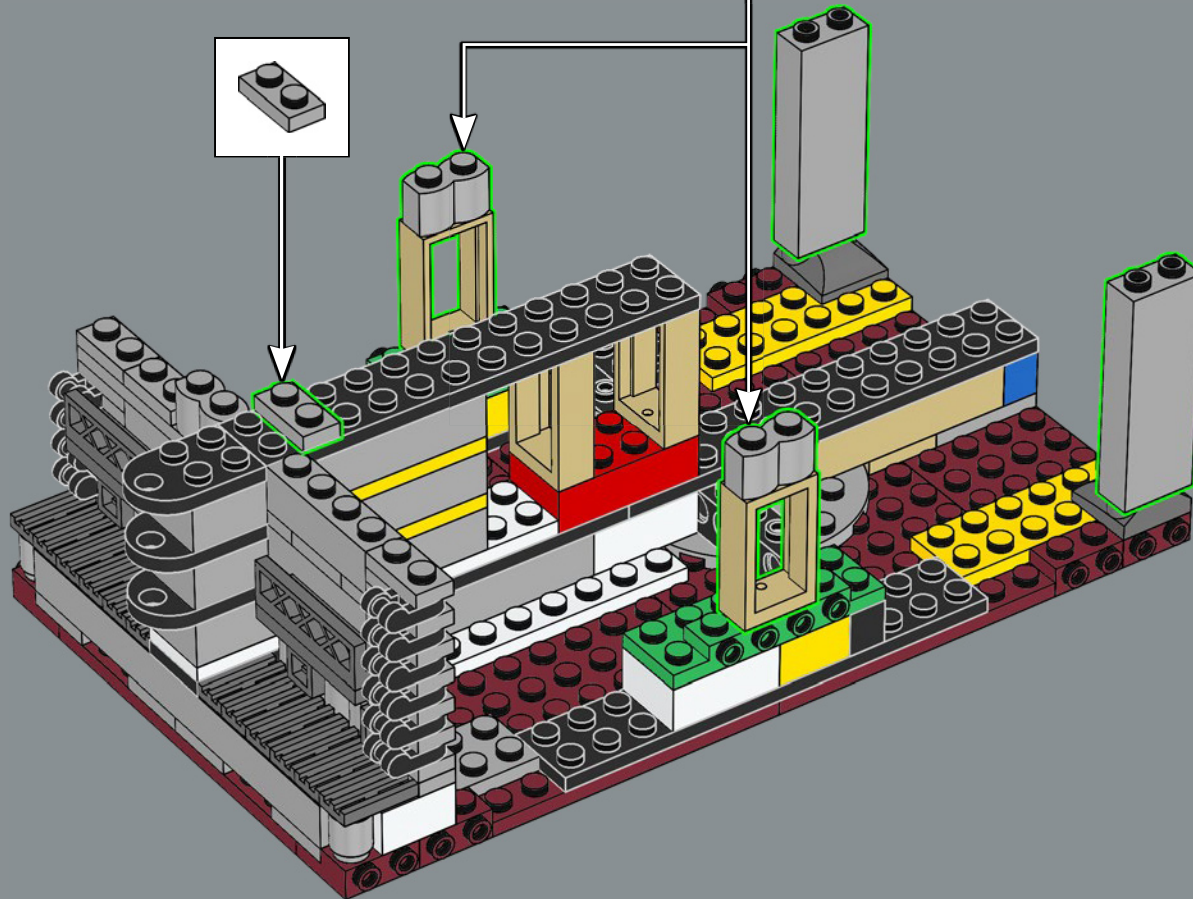
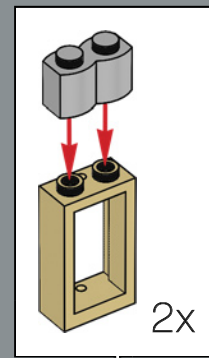

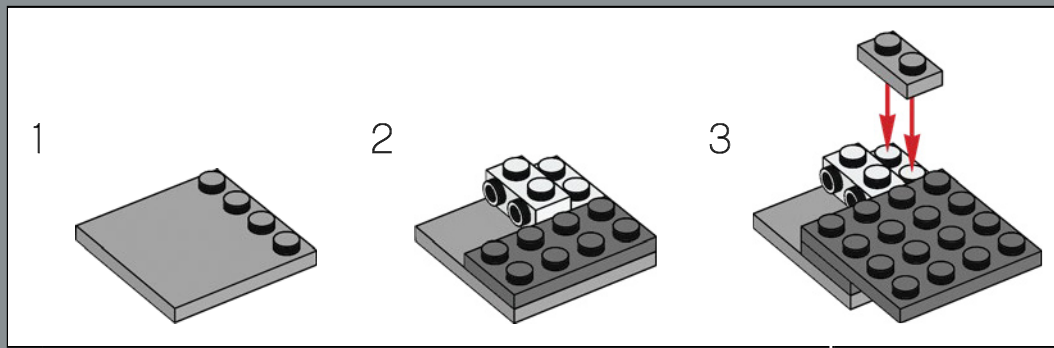
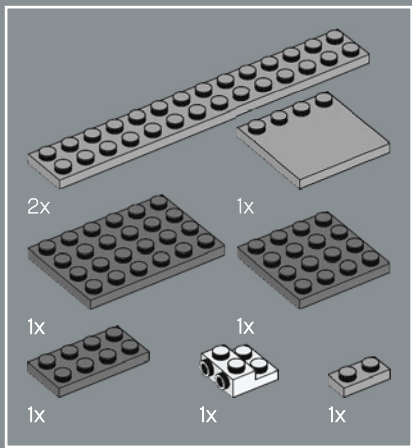

35

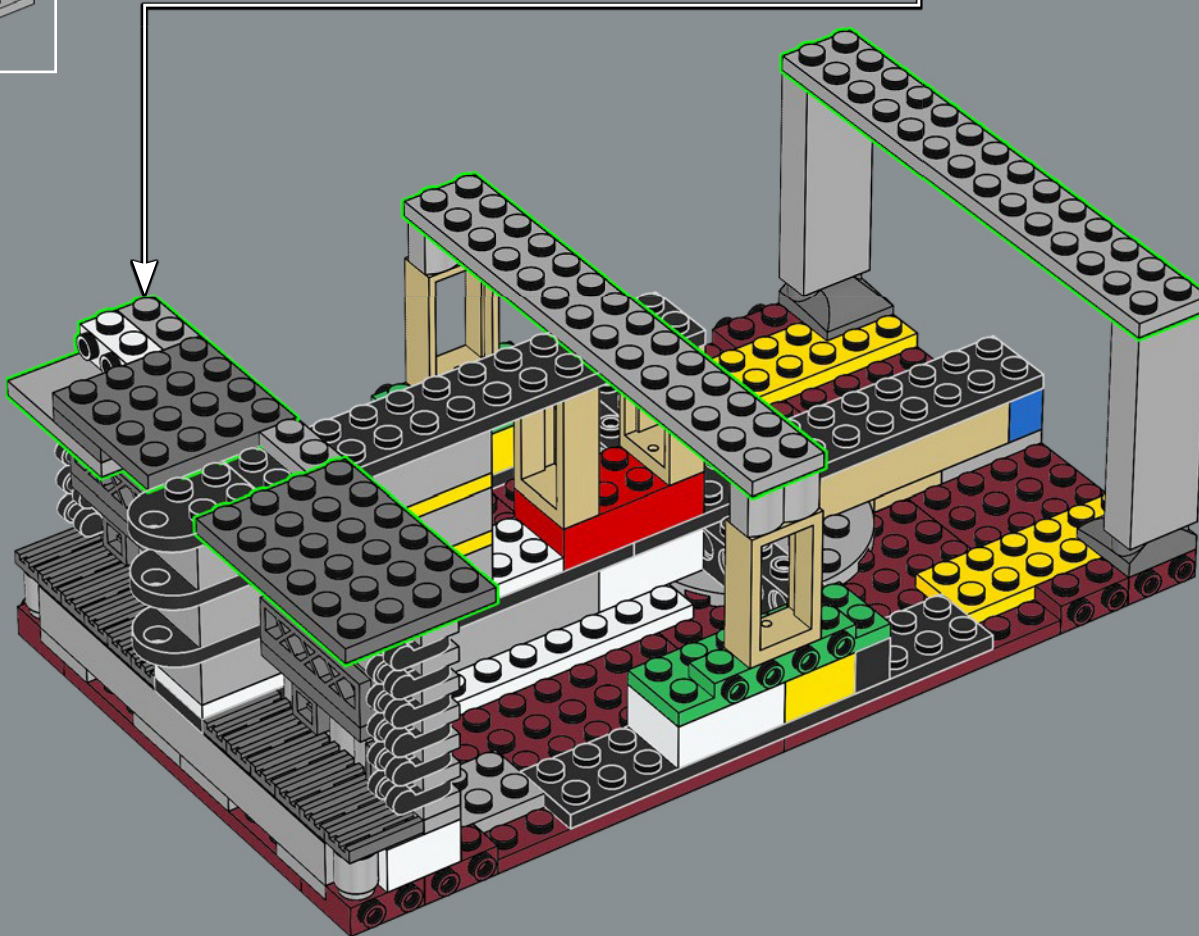

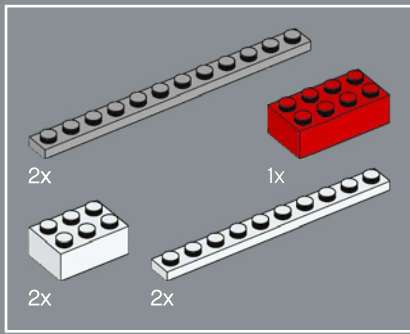

36

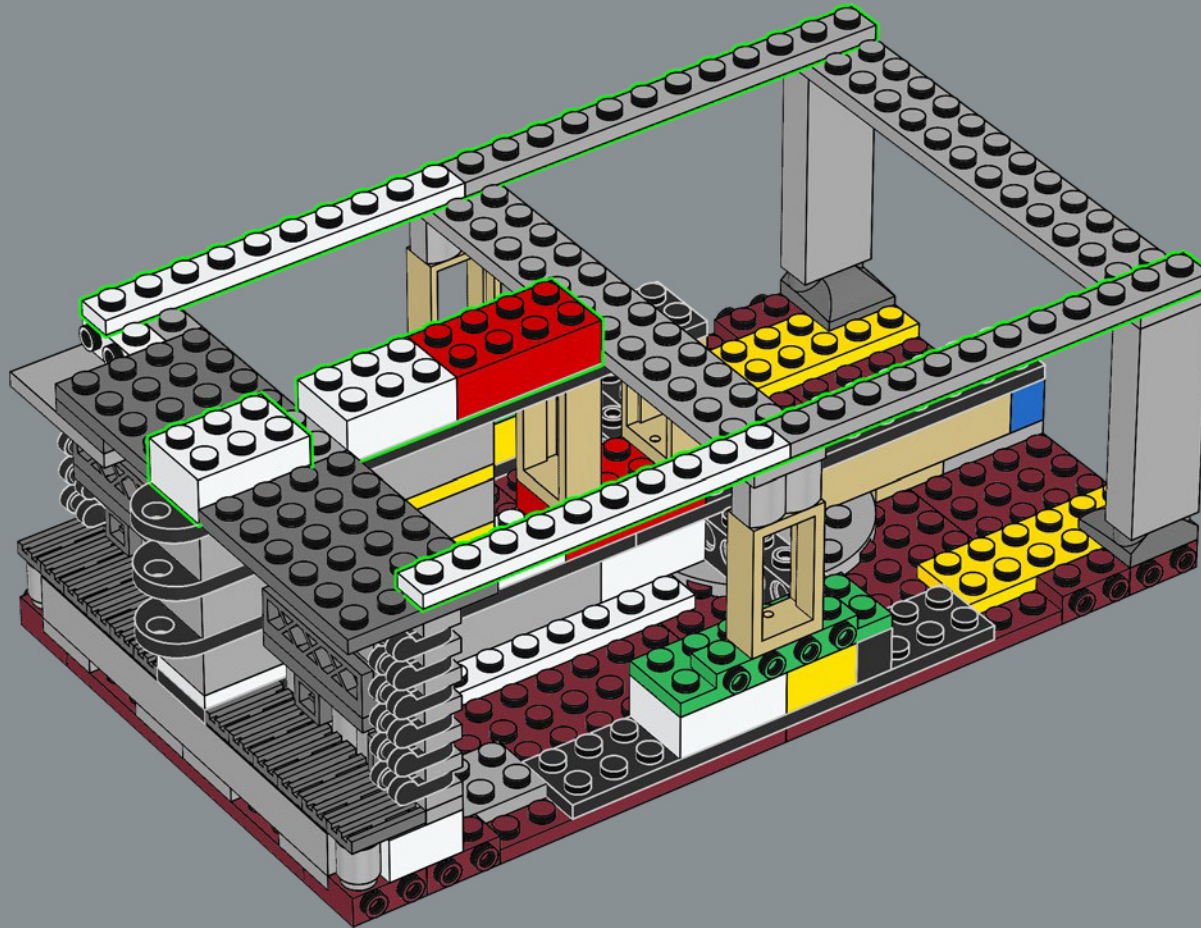

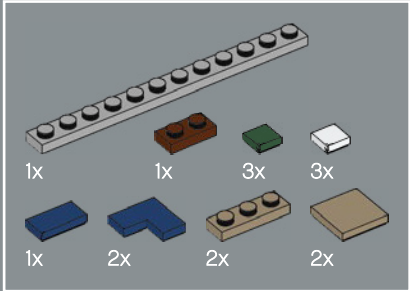
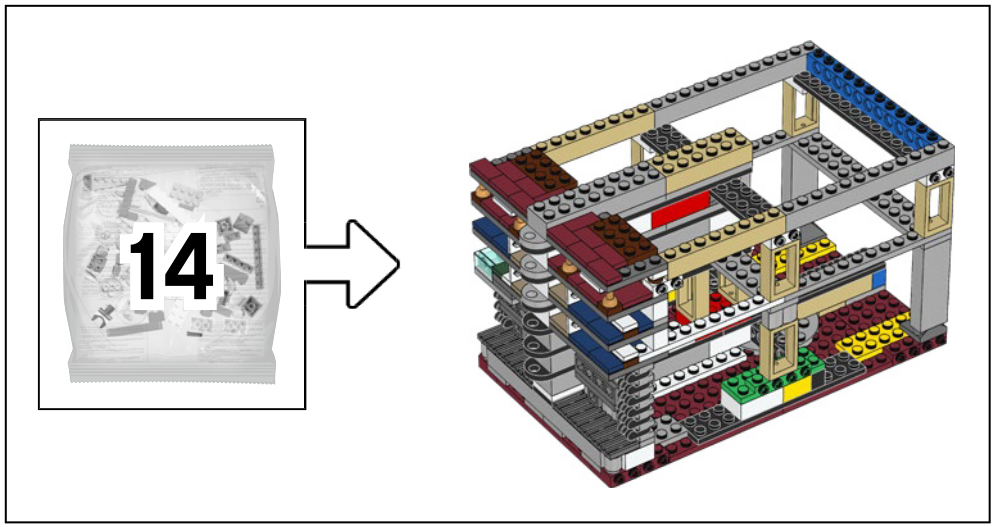

37

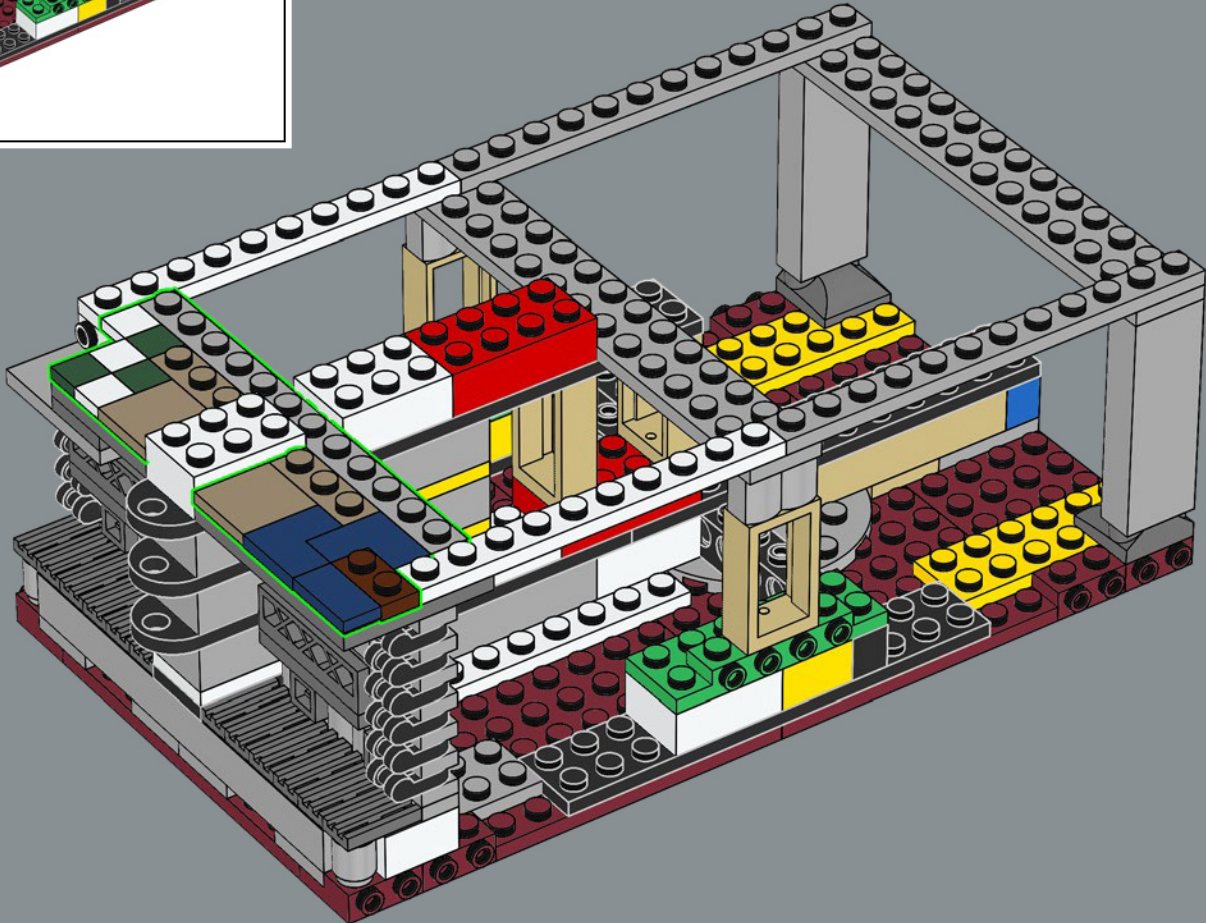

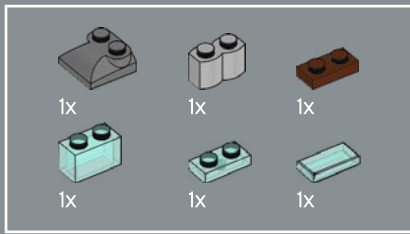

38

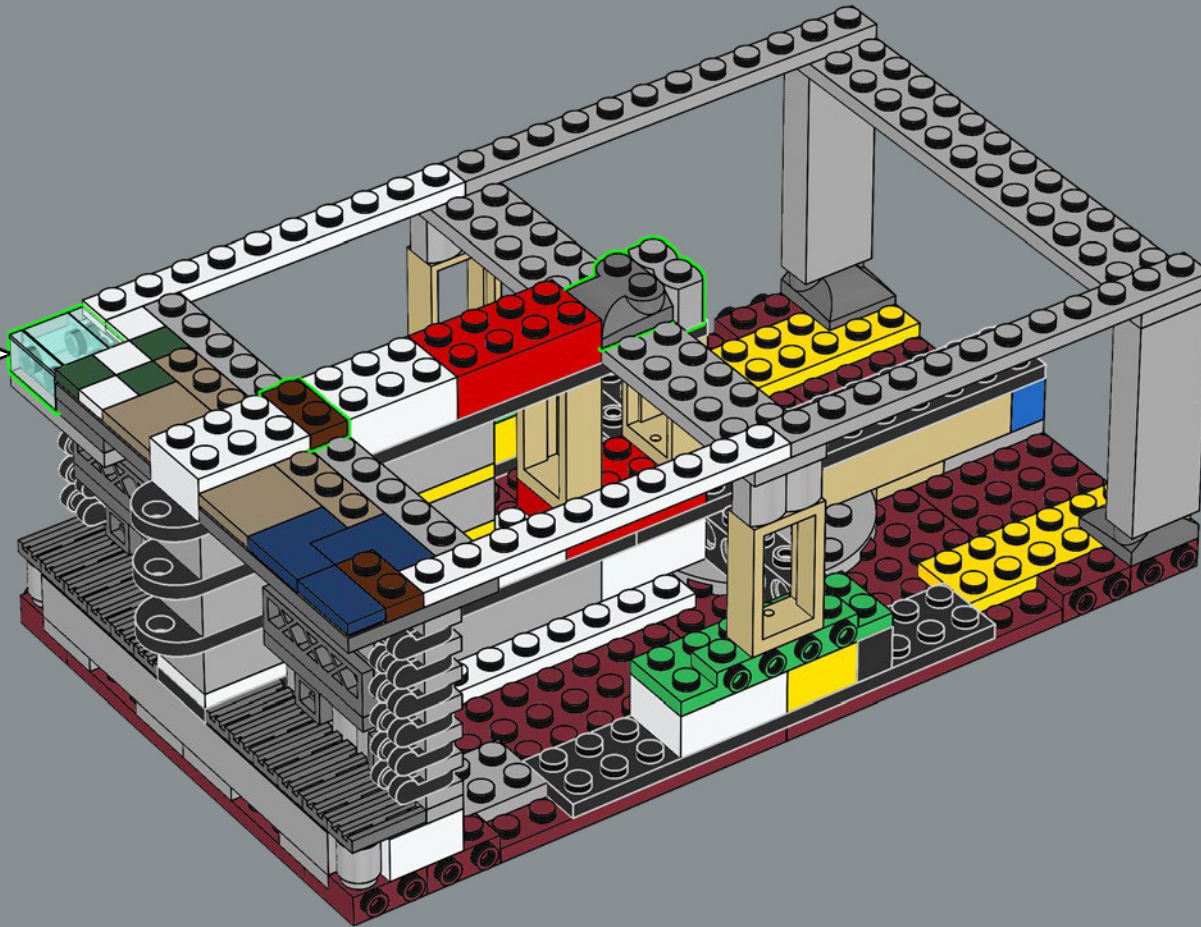
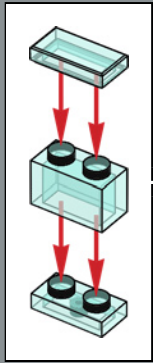

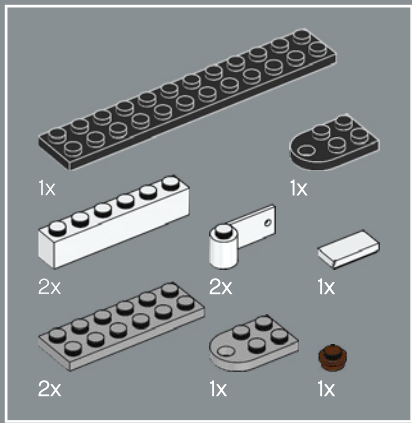

39

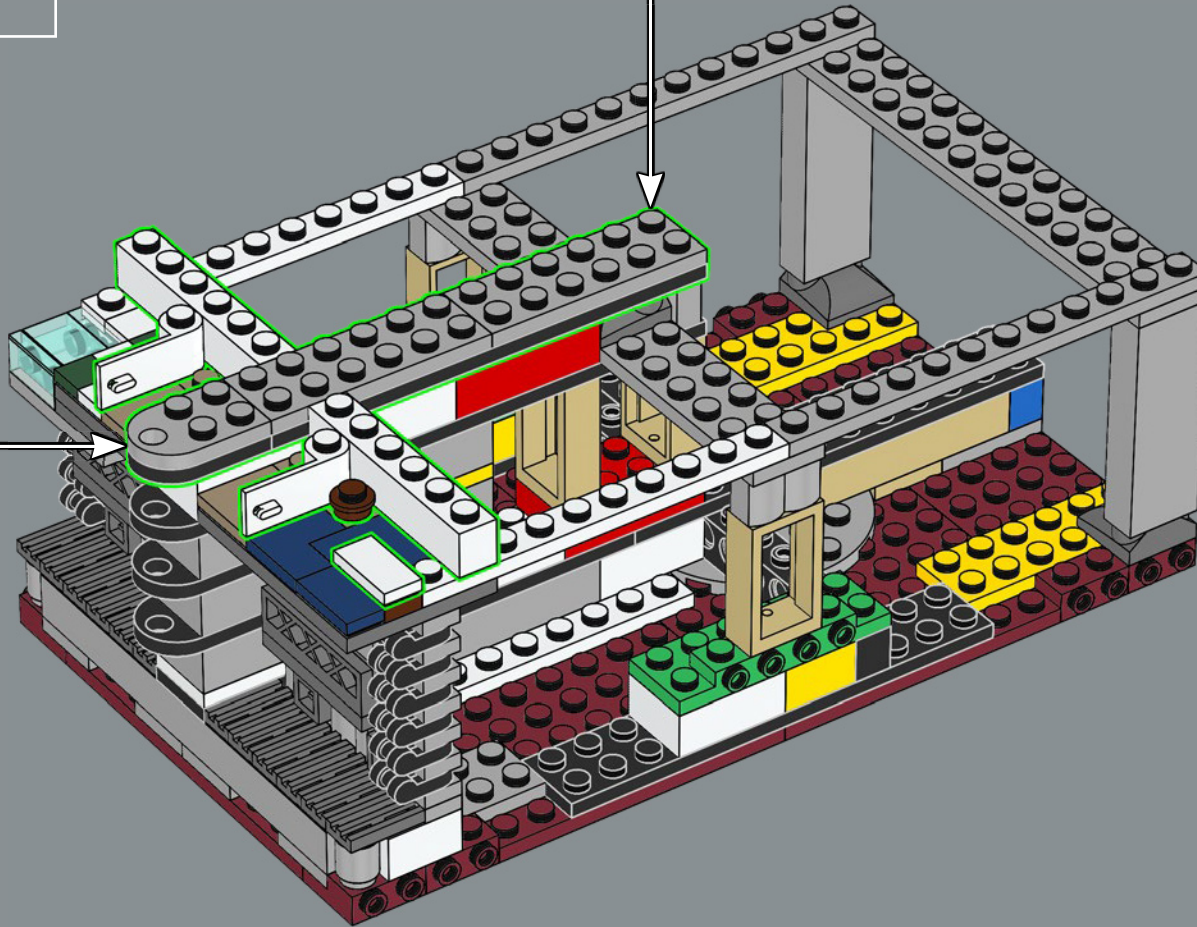
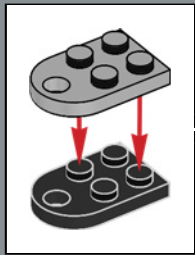
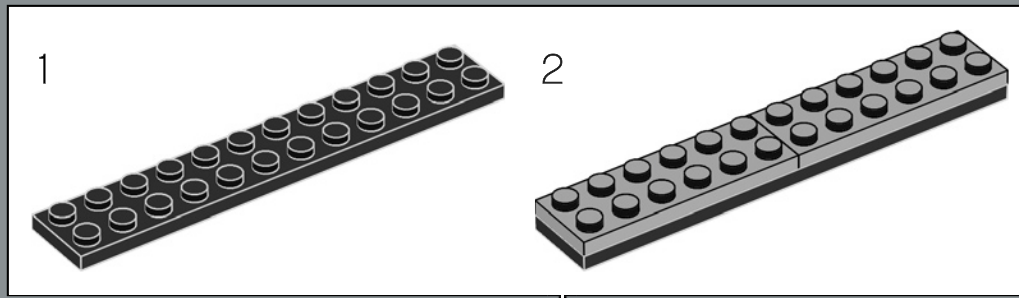

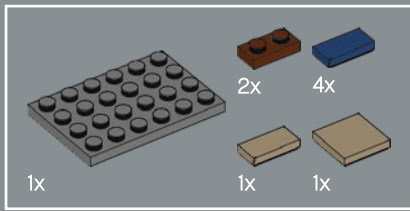

40

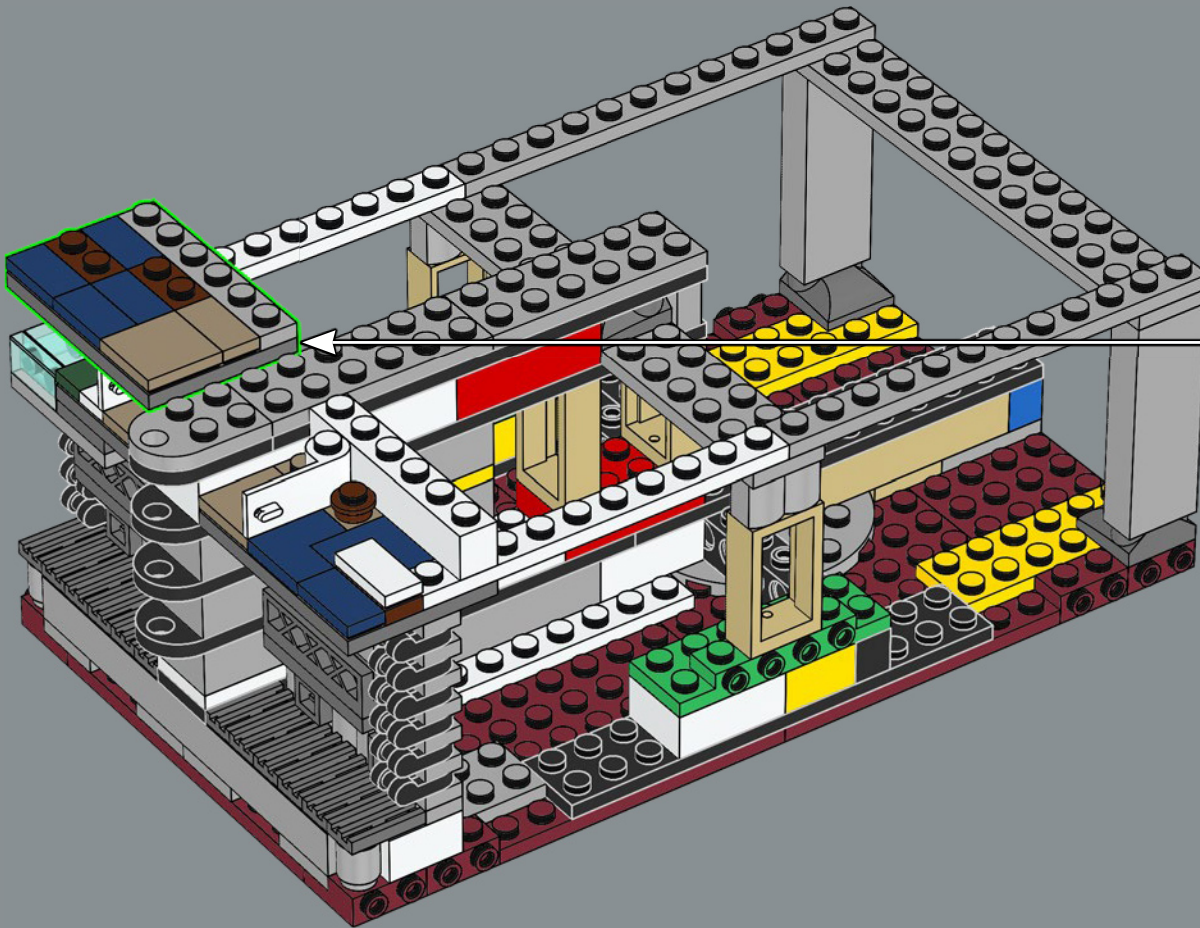
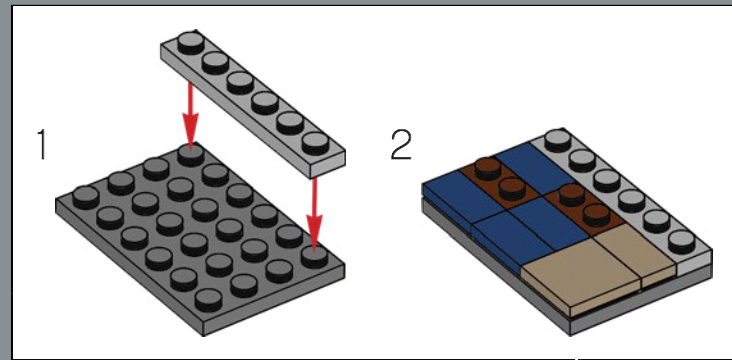

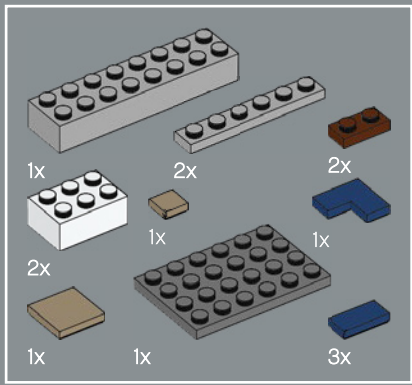

41

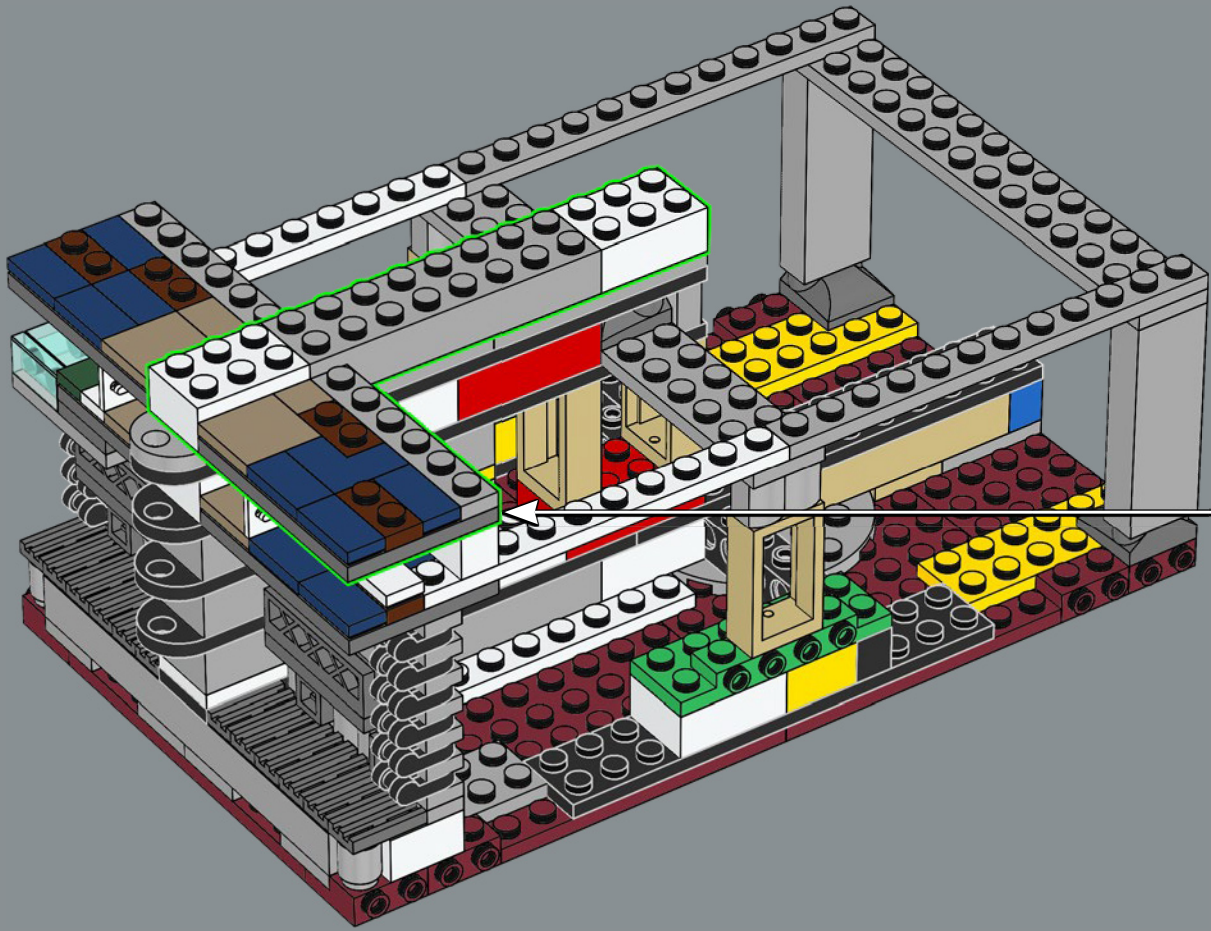
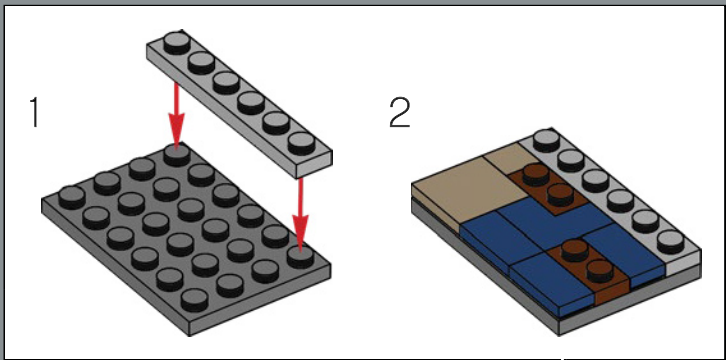



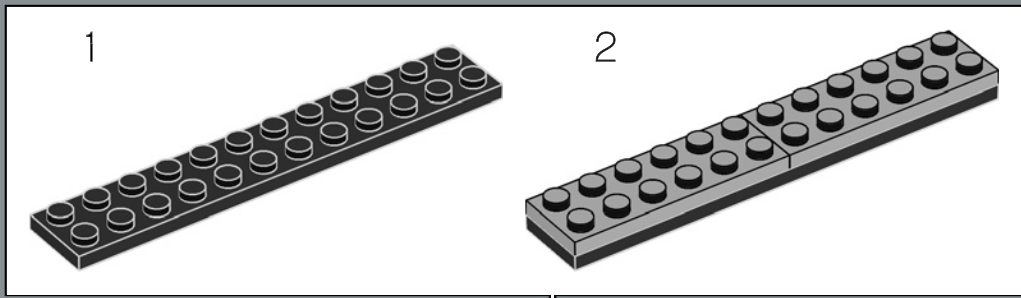
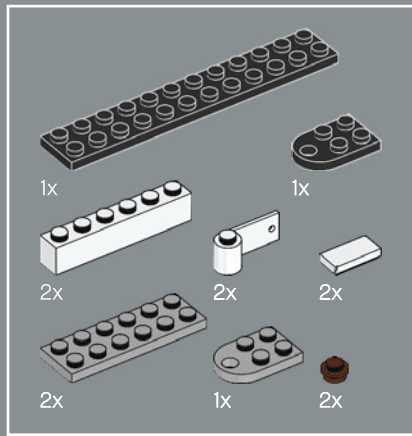

42

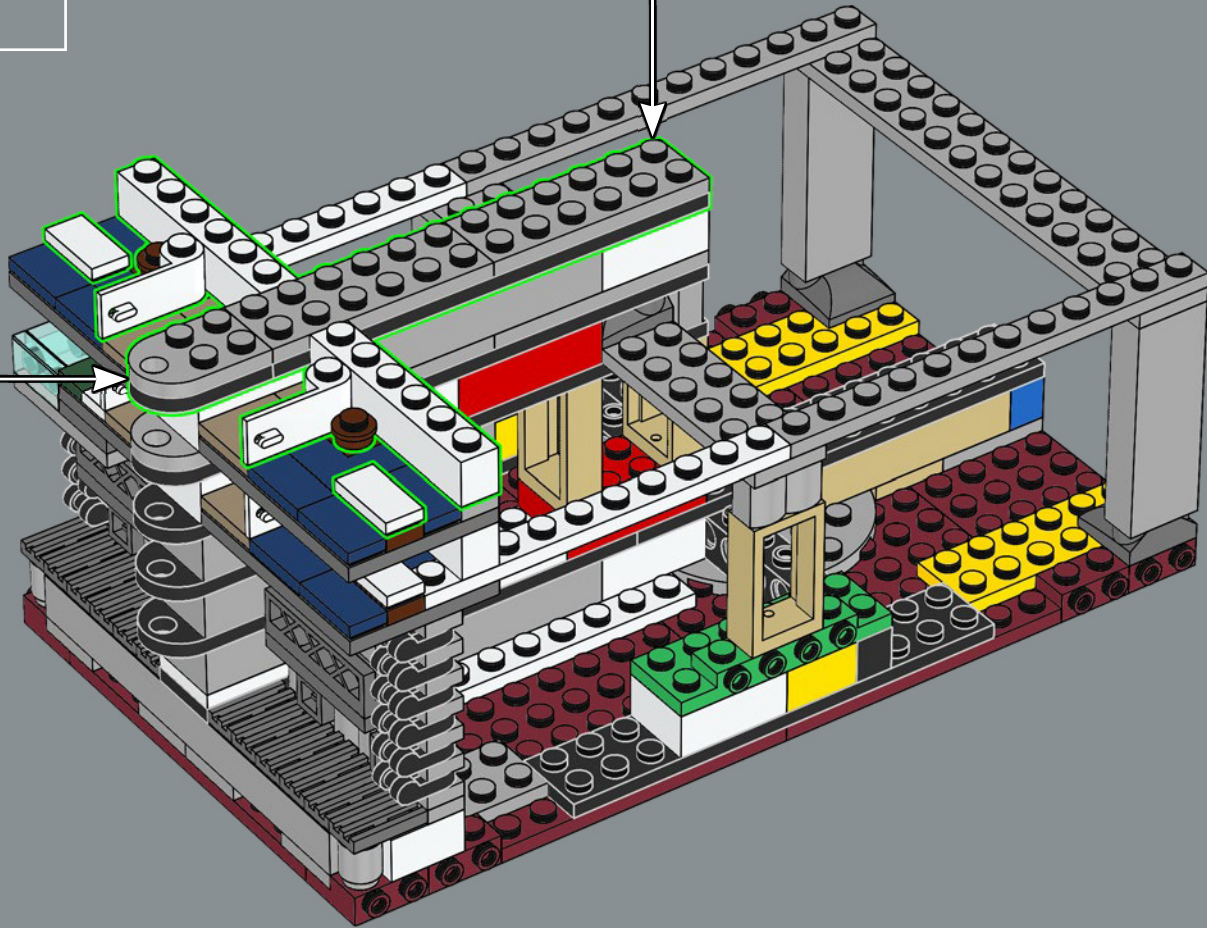
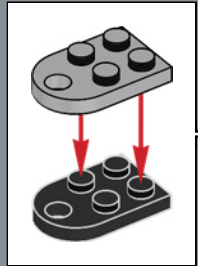

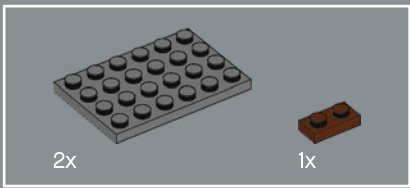

43

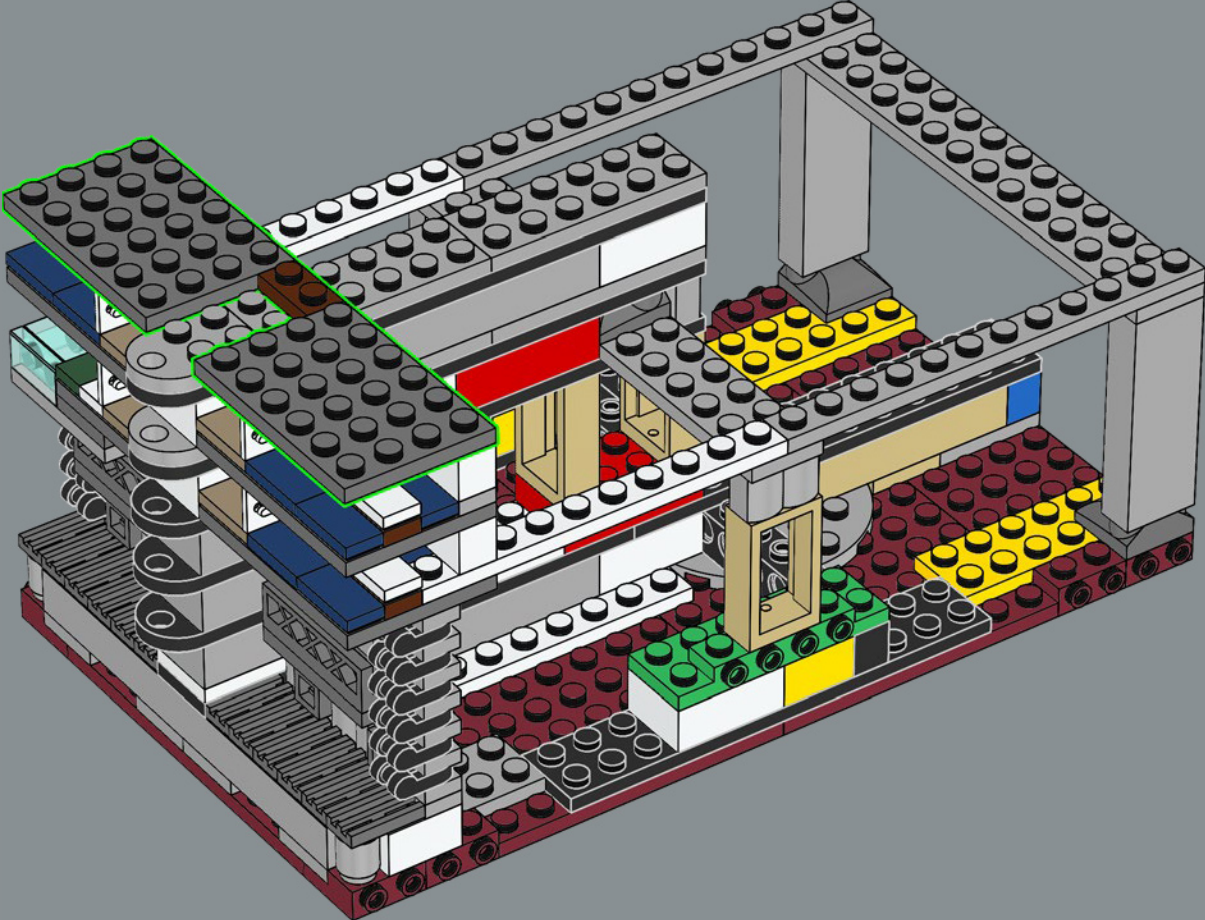

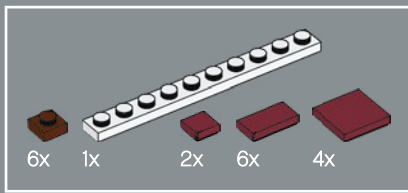

44

Das Wasserwerk war in der Lage, alle Kabinen und Räume zu heizen und Wasser in jeden Teil des Schiffs zu pumpen.

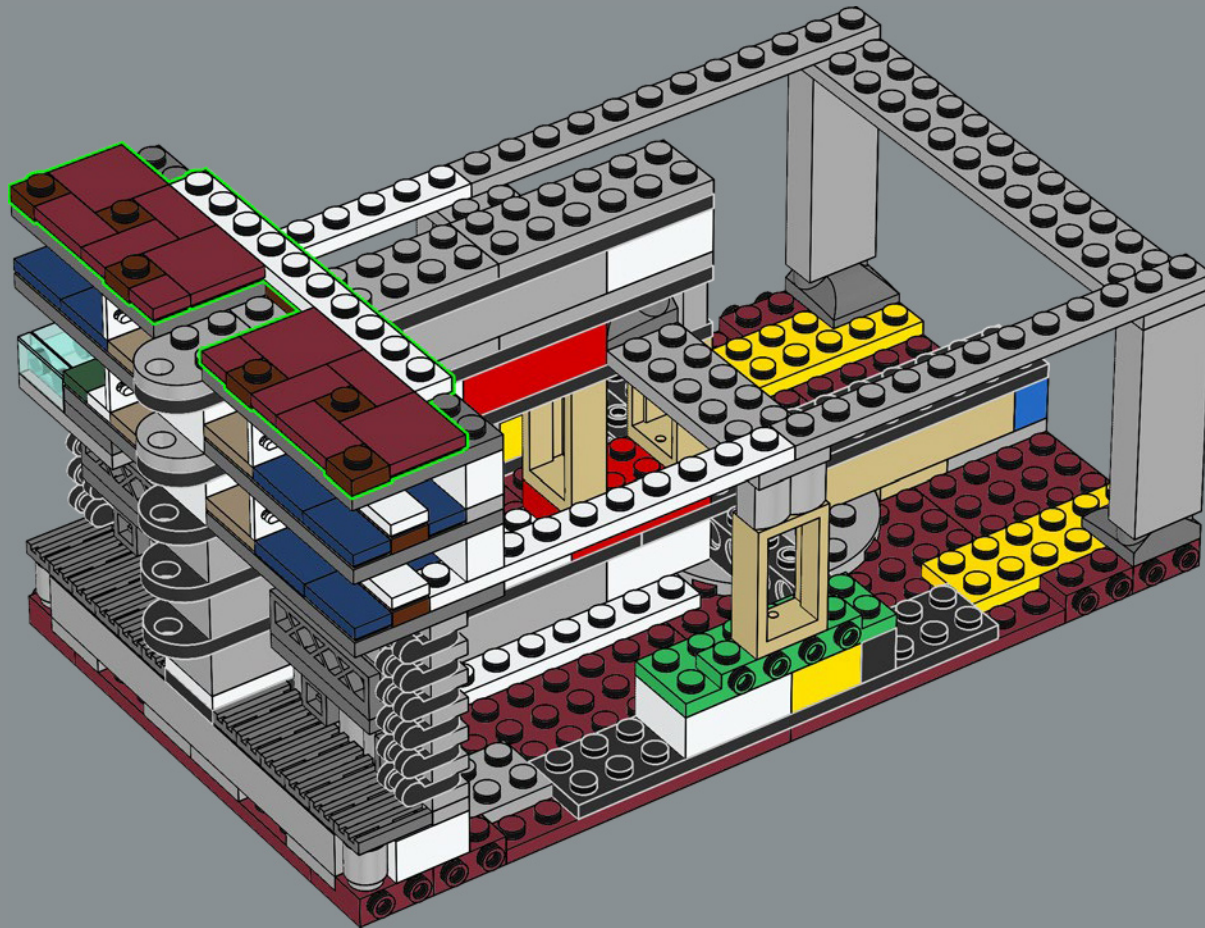

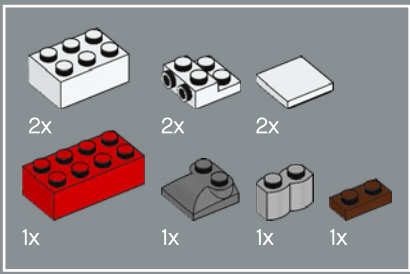

45

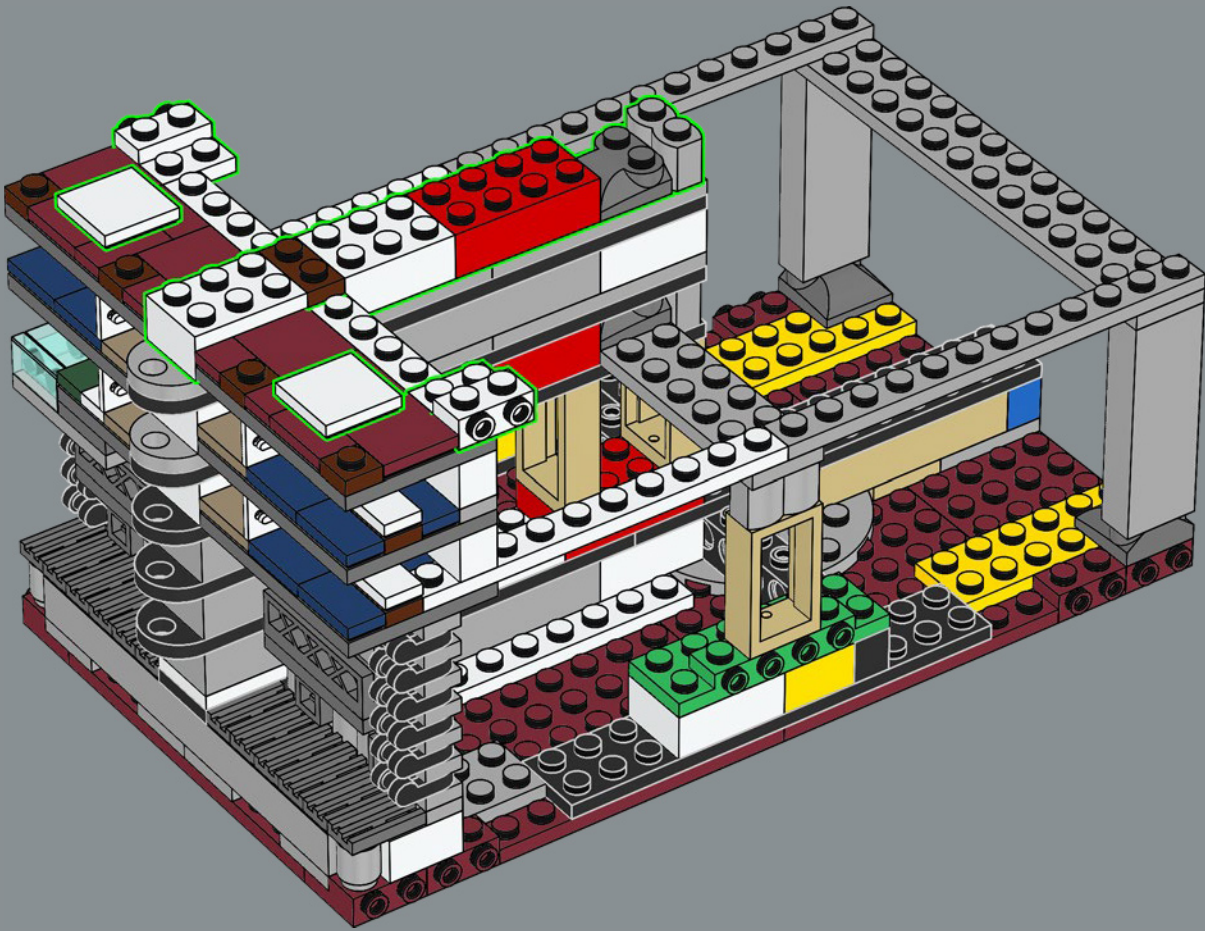

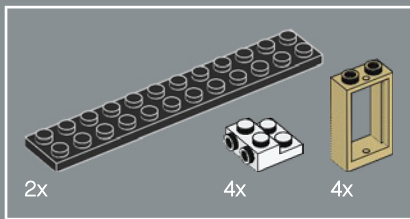

46

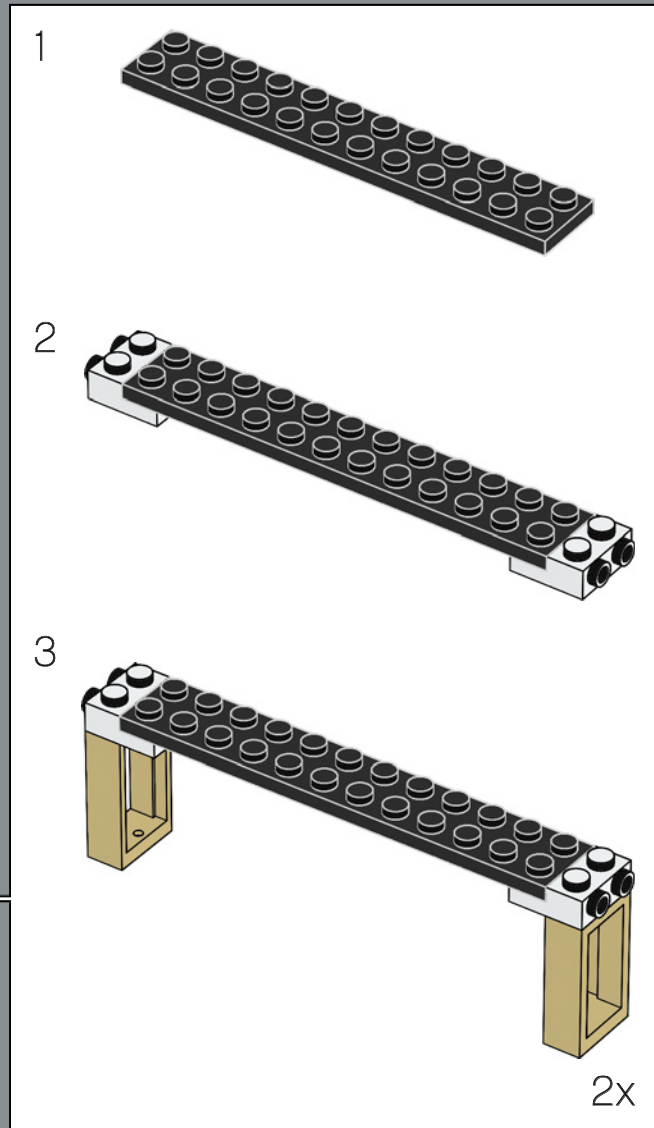
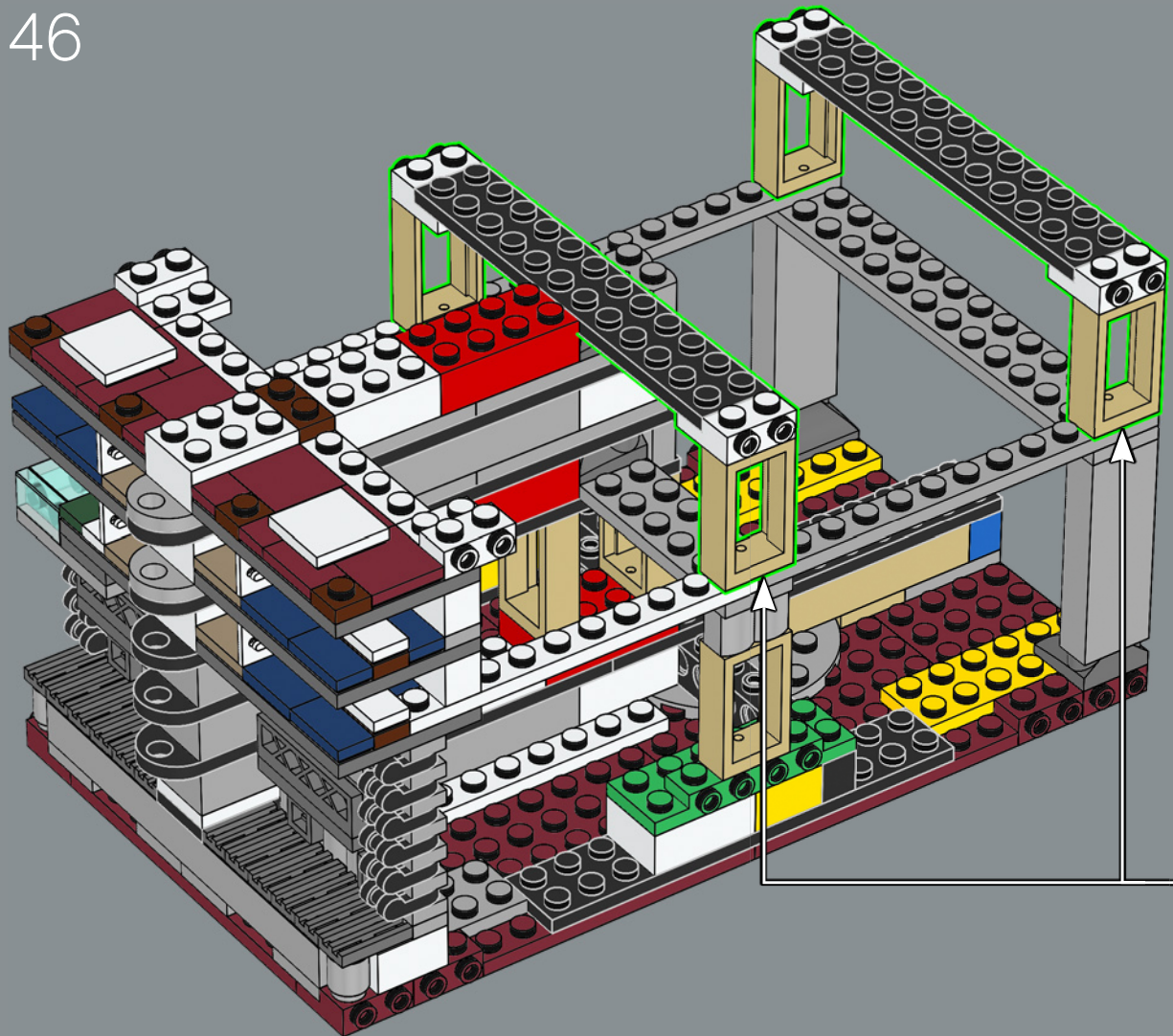

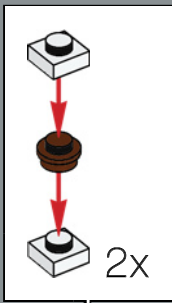
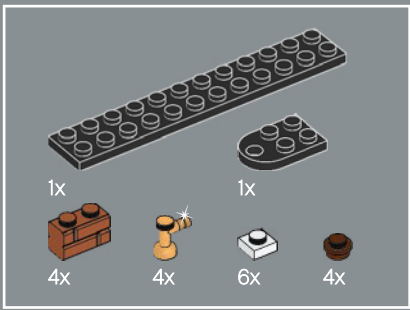

47

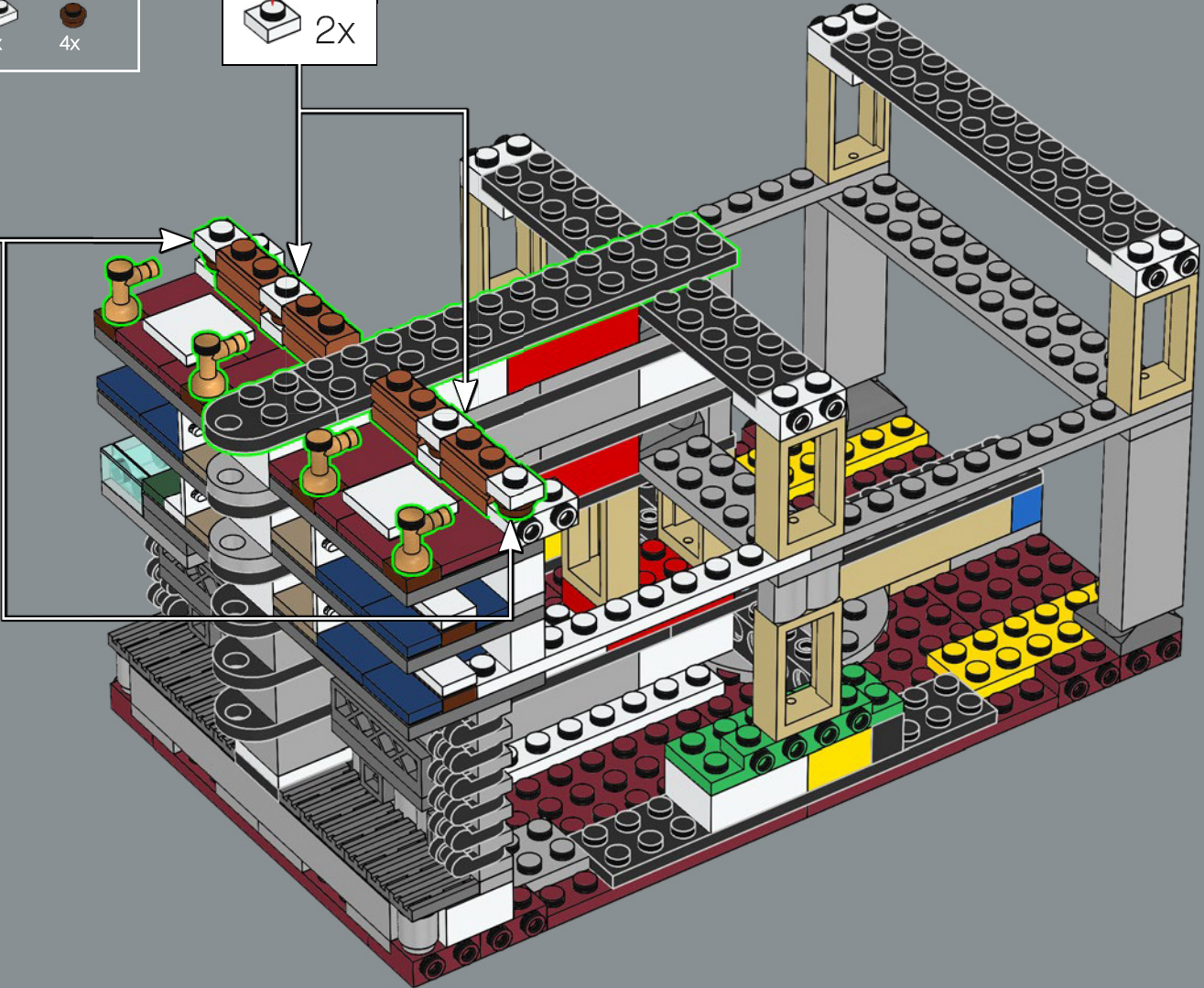
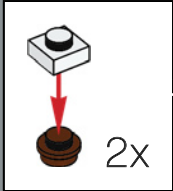

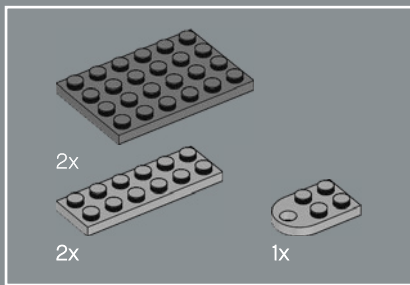

48

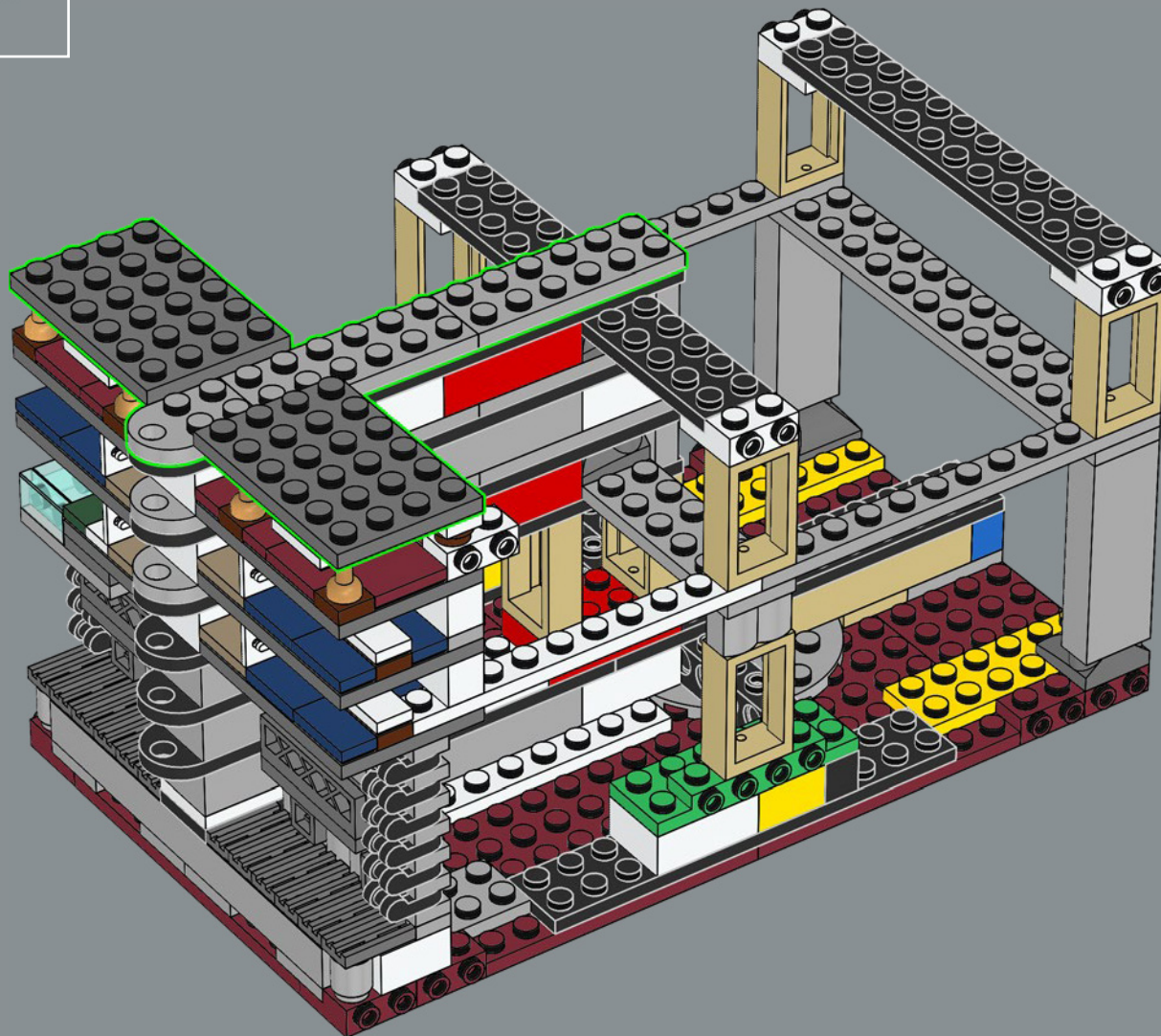



49

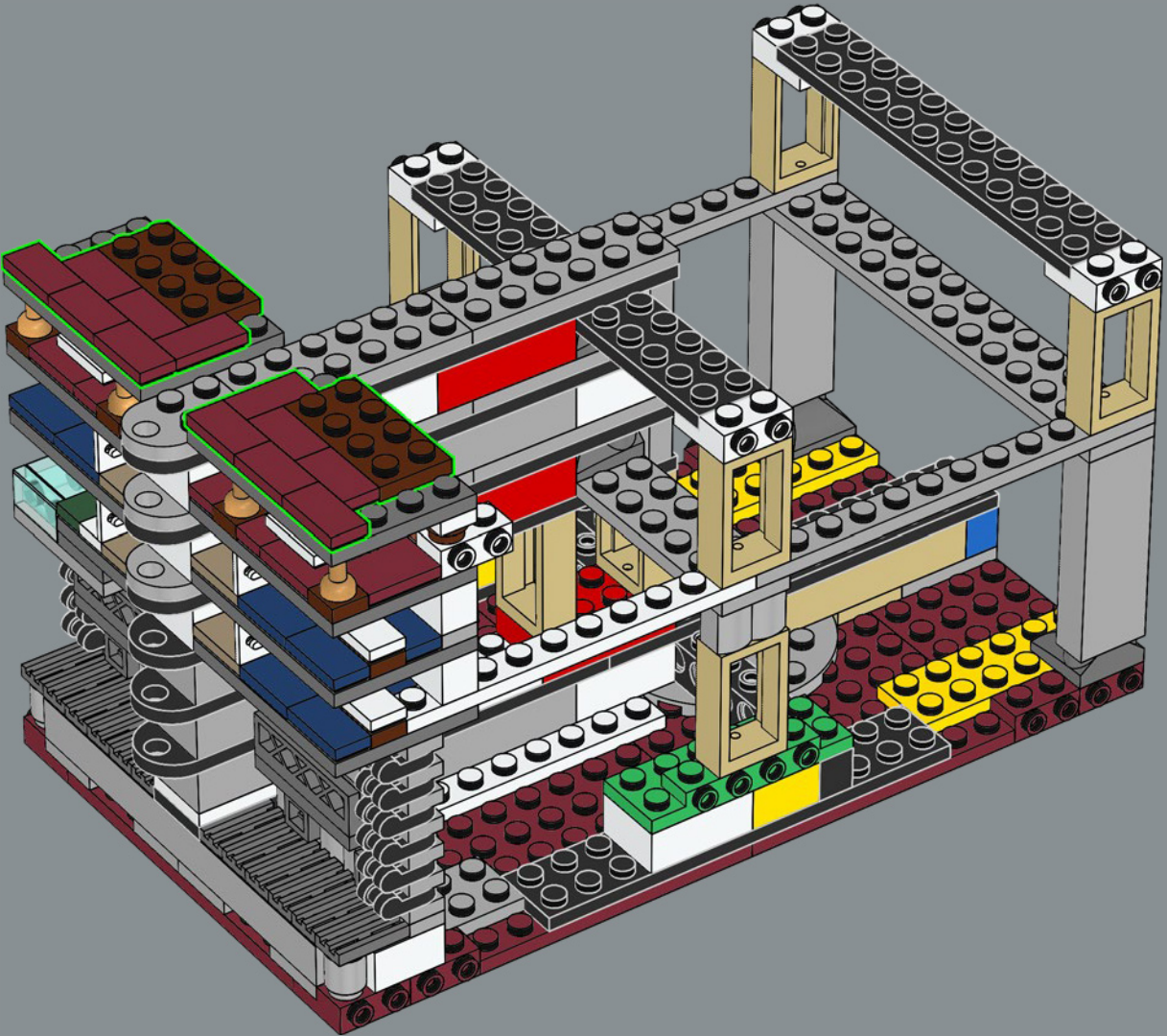



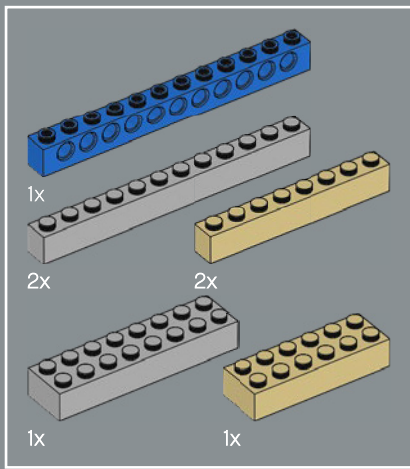

50

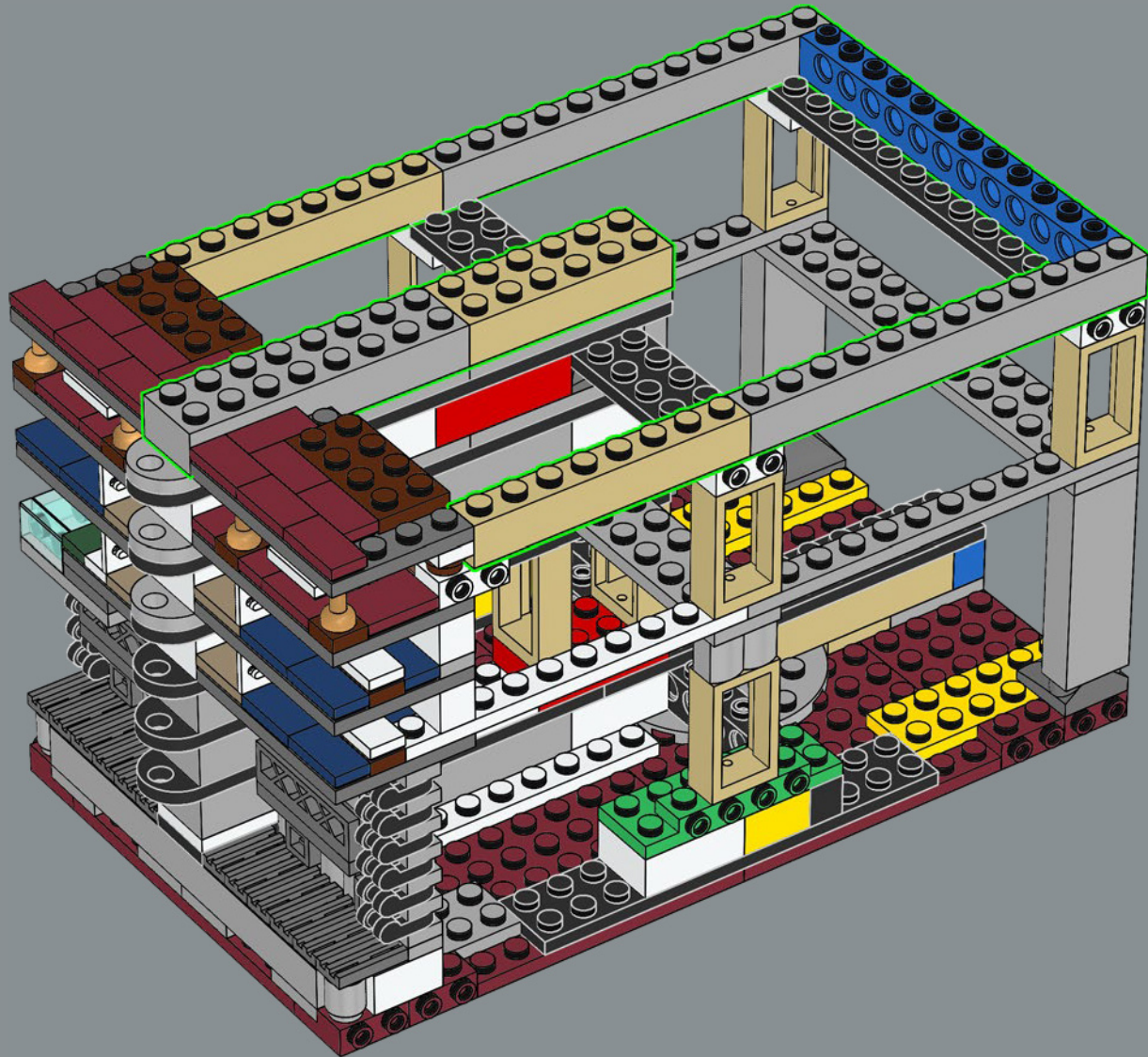

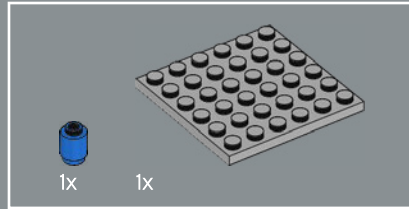
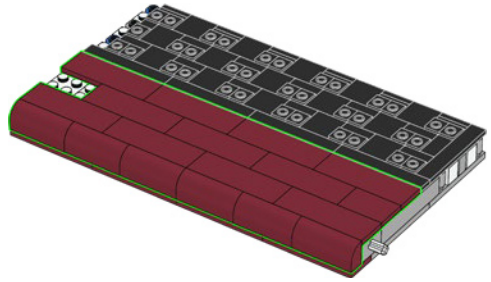
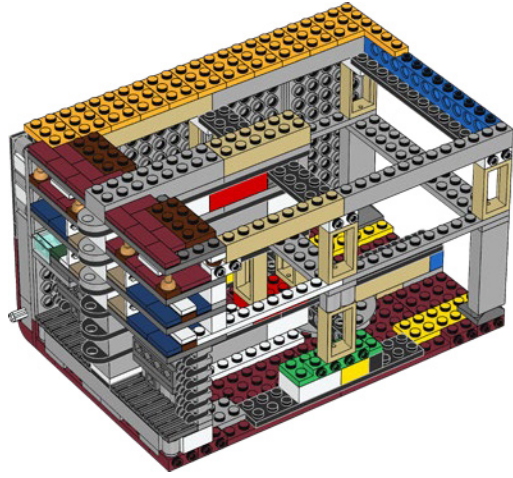
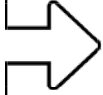

51

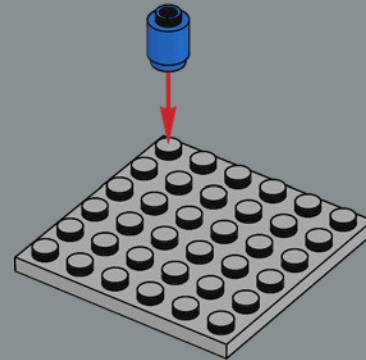

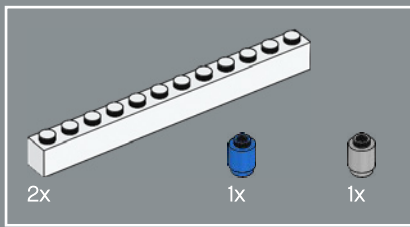

52

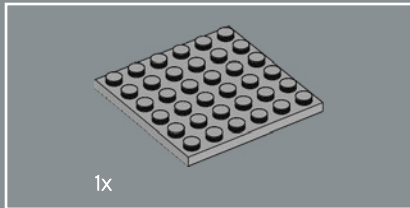
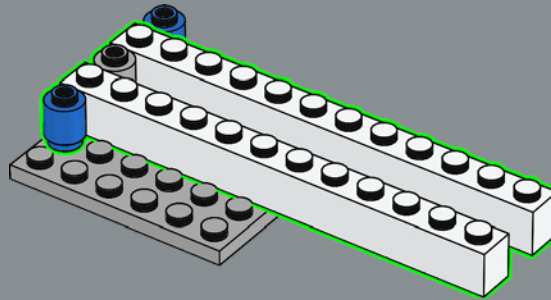

53

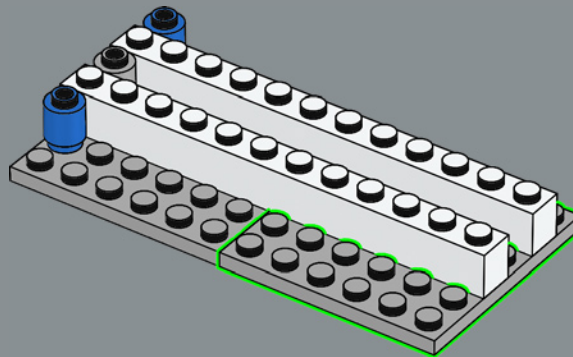

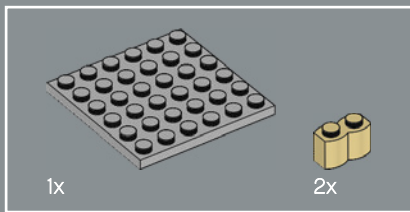

54

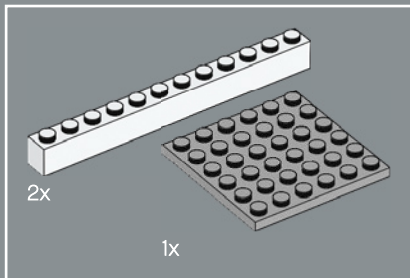
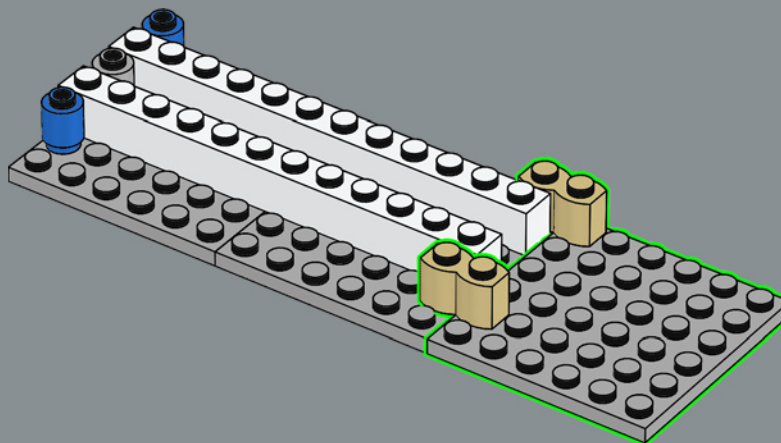

55

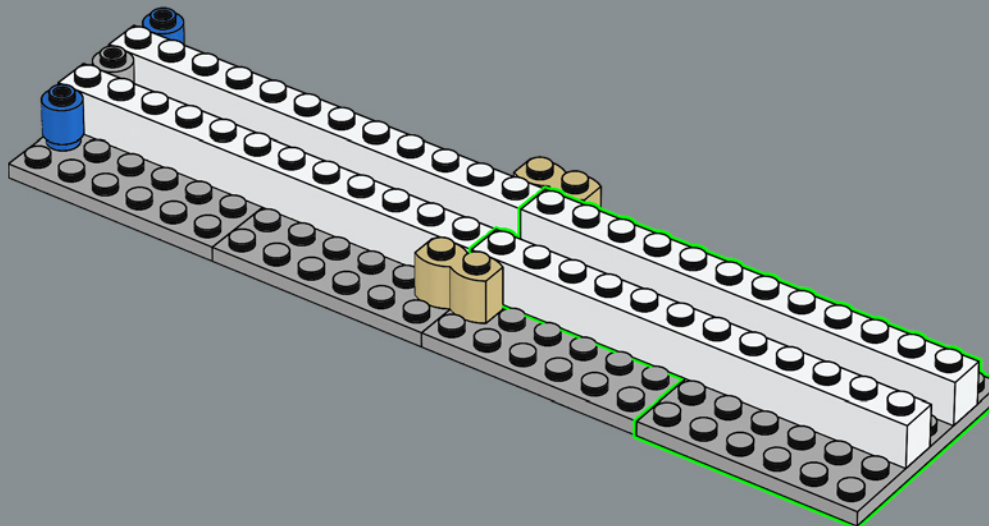

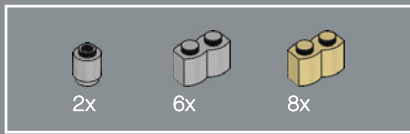

56

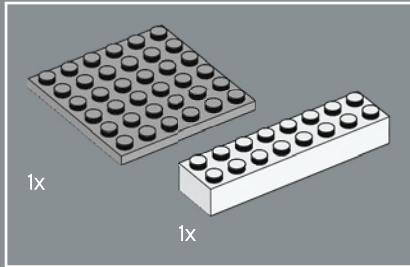
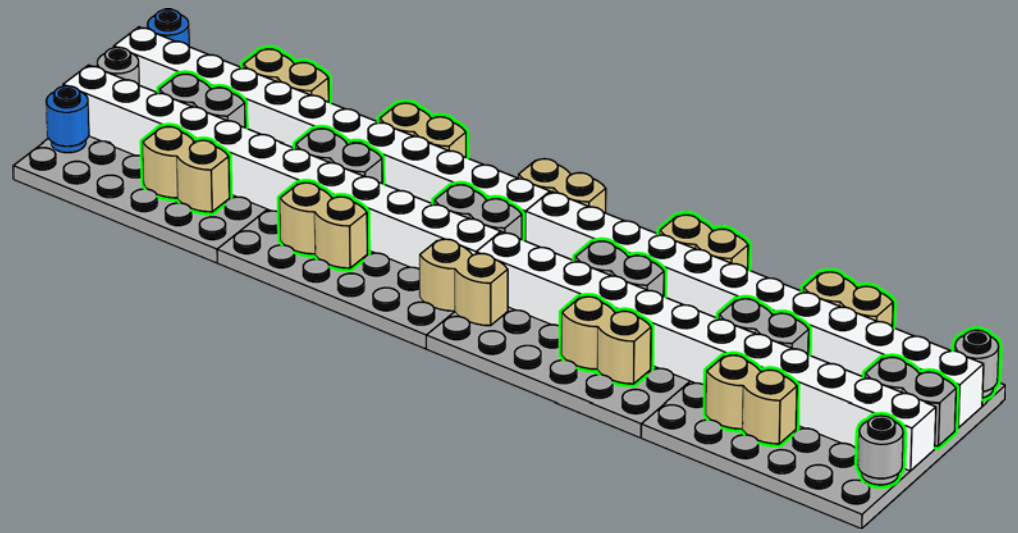

57

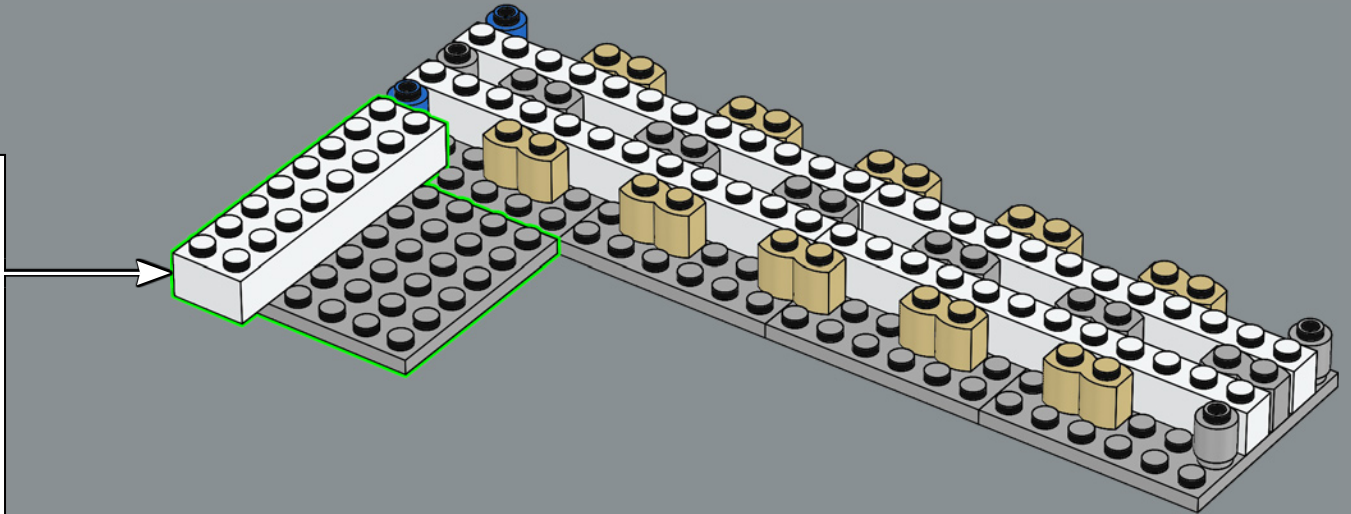
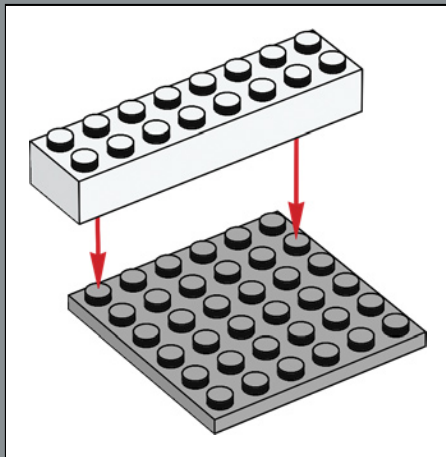

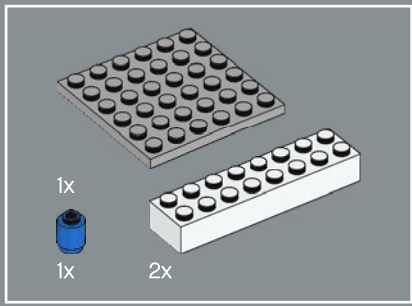

58

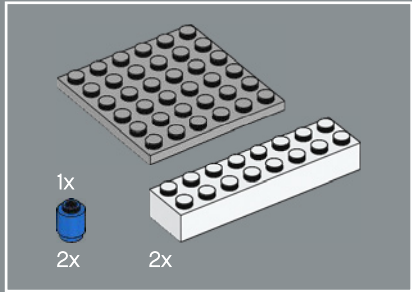
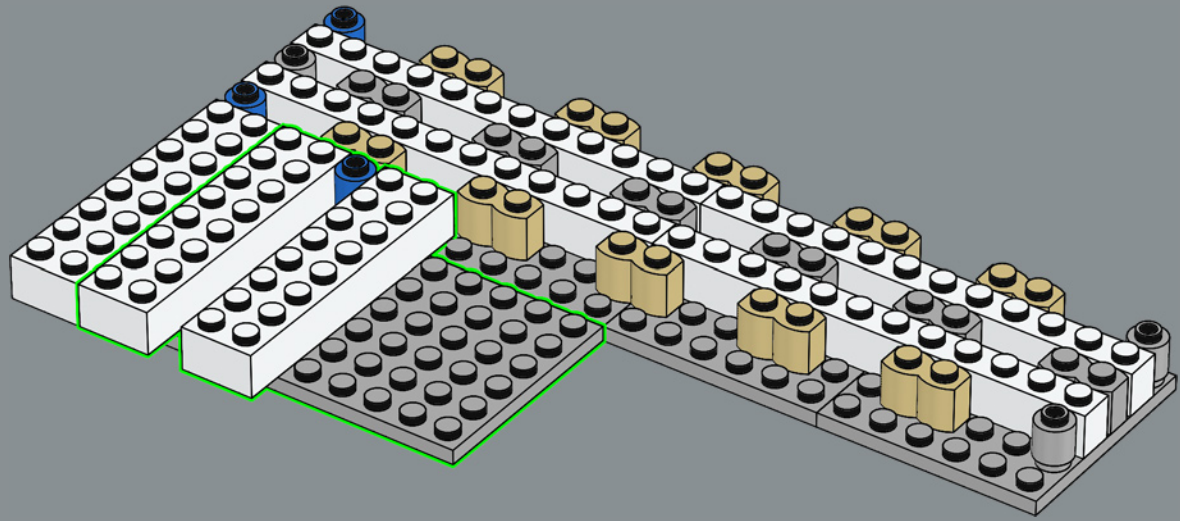

59

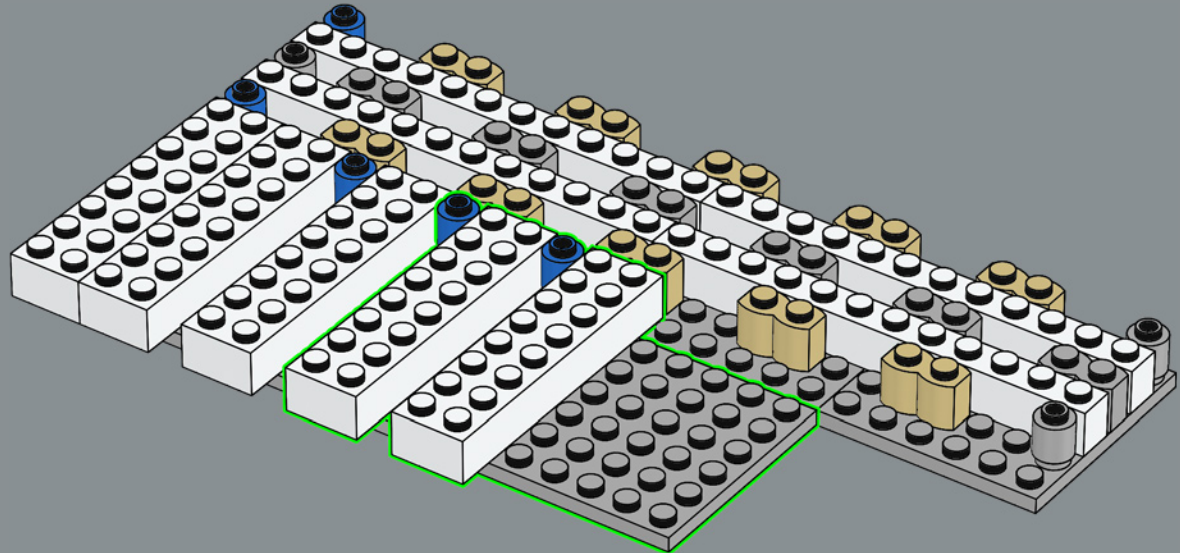

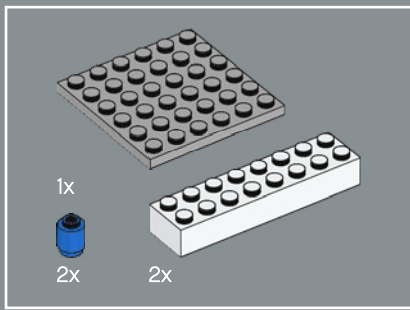

60

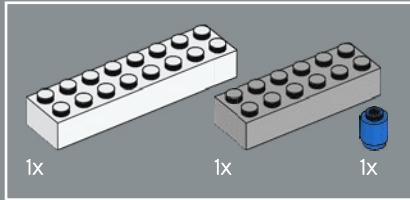
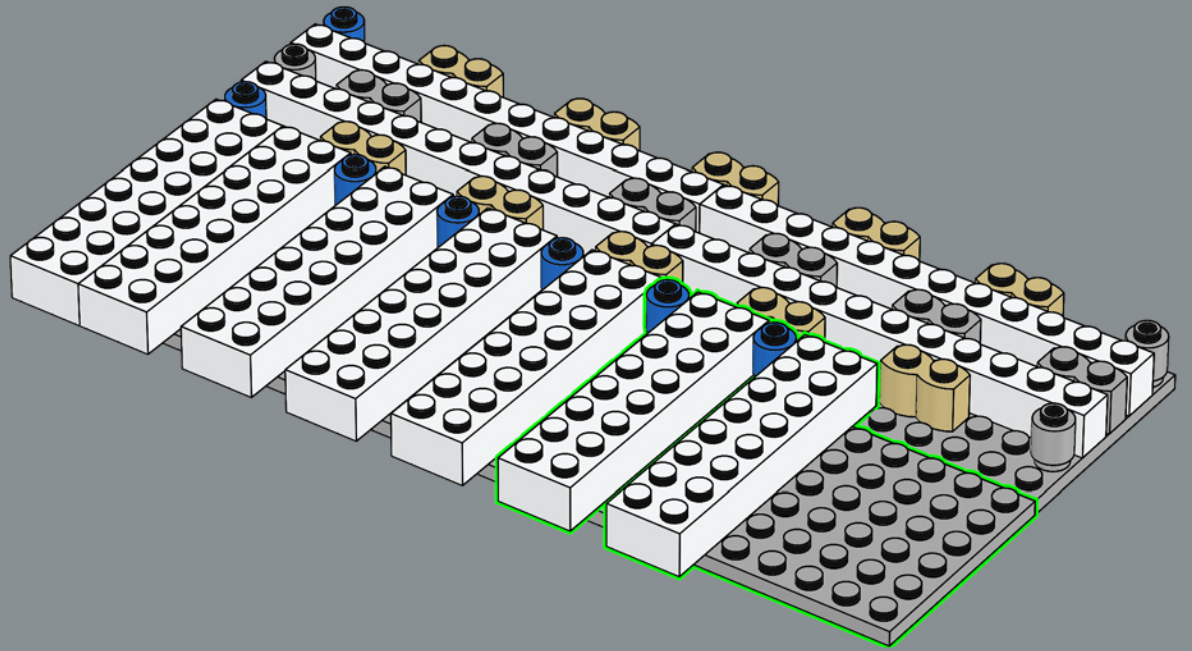

61

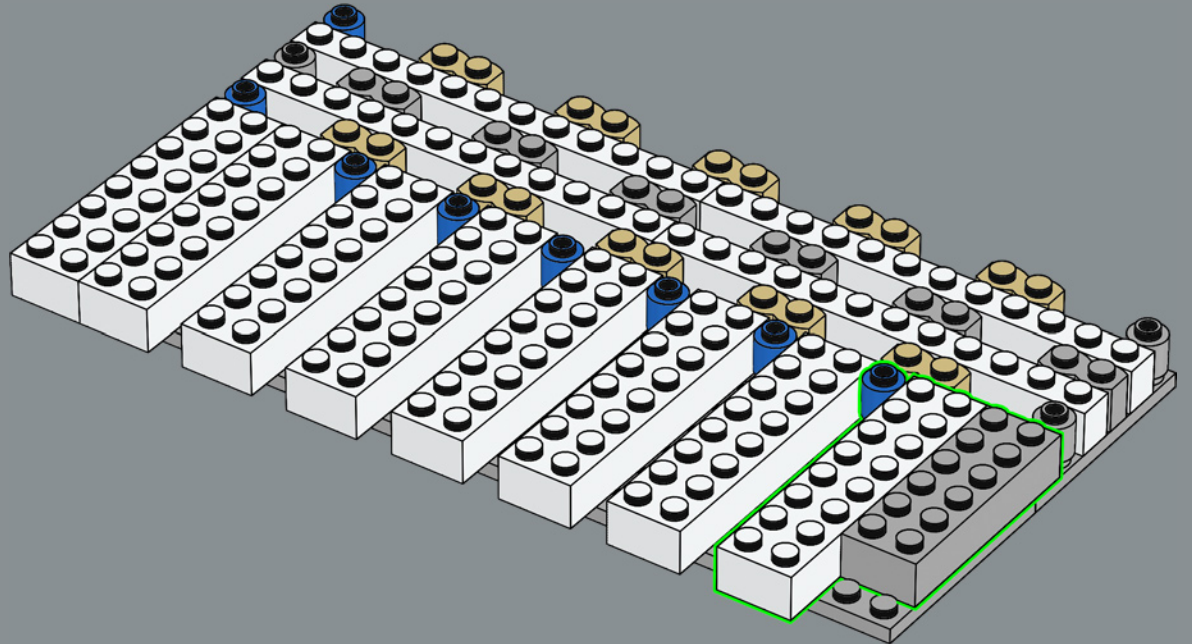

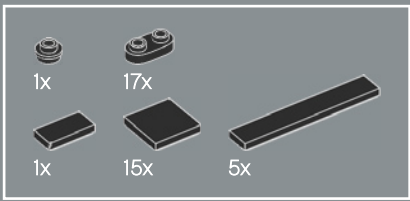

62

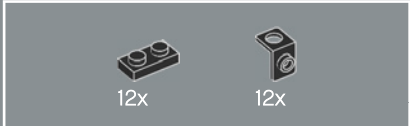
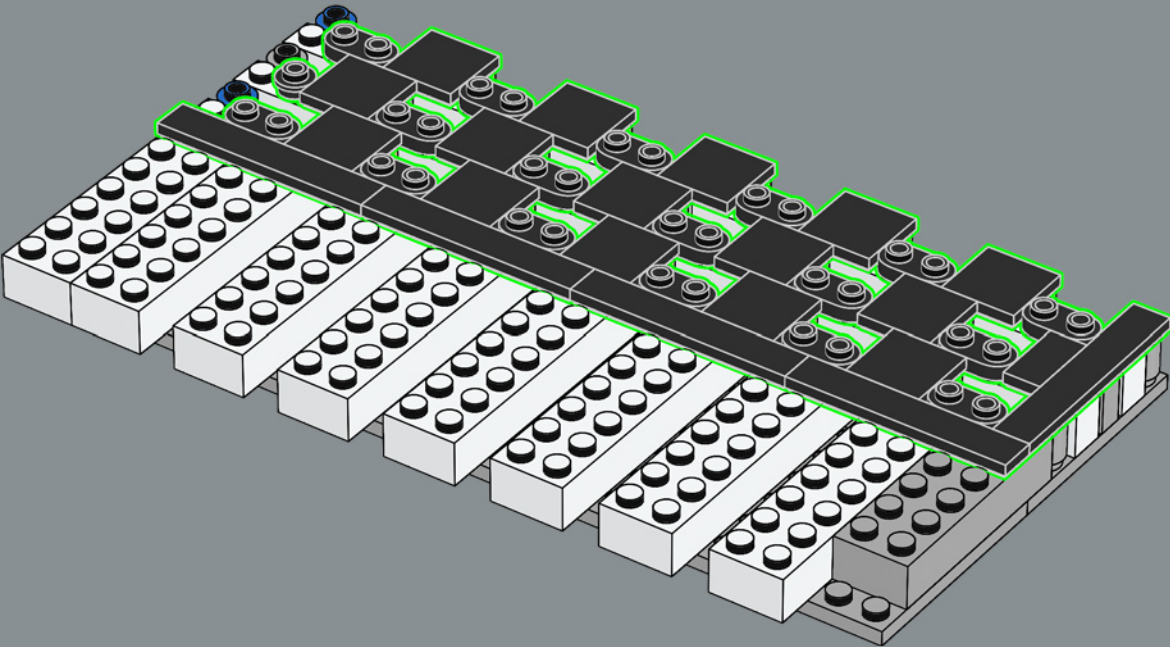

63

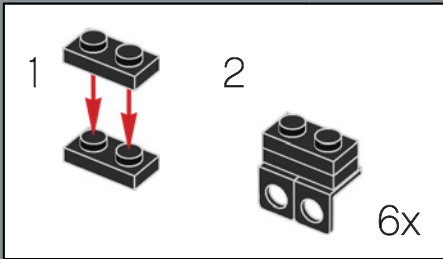
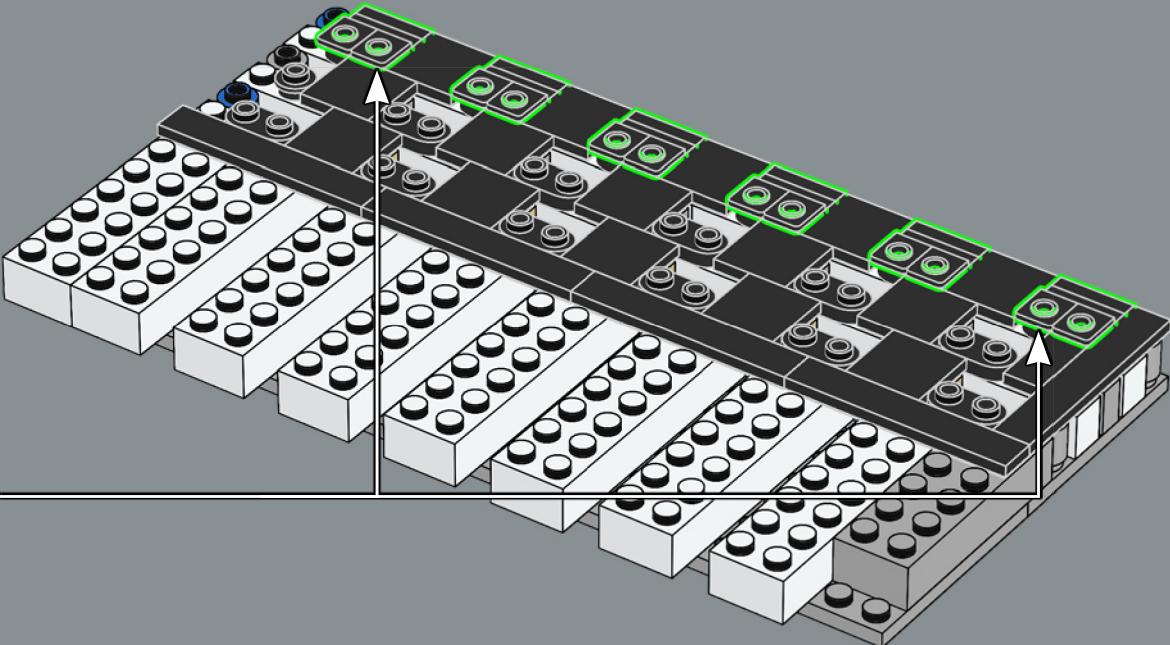



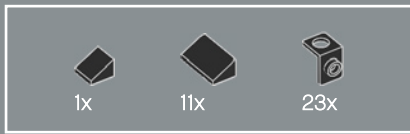

64

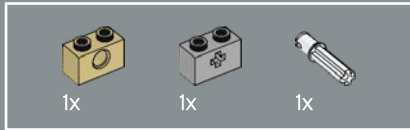
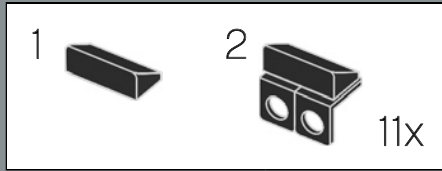
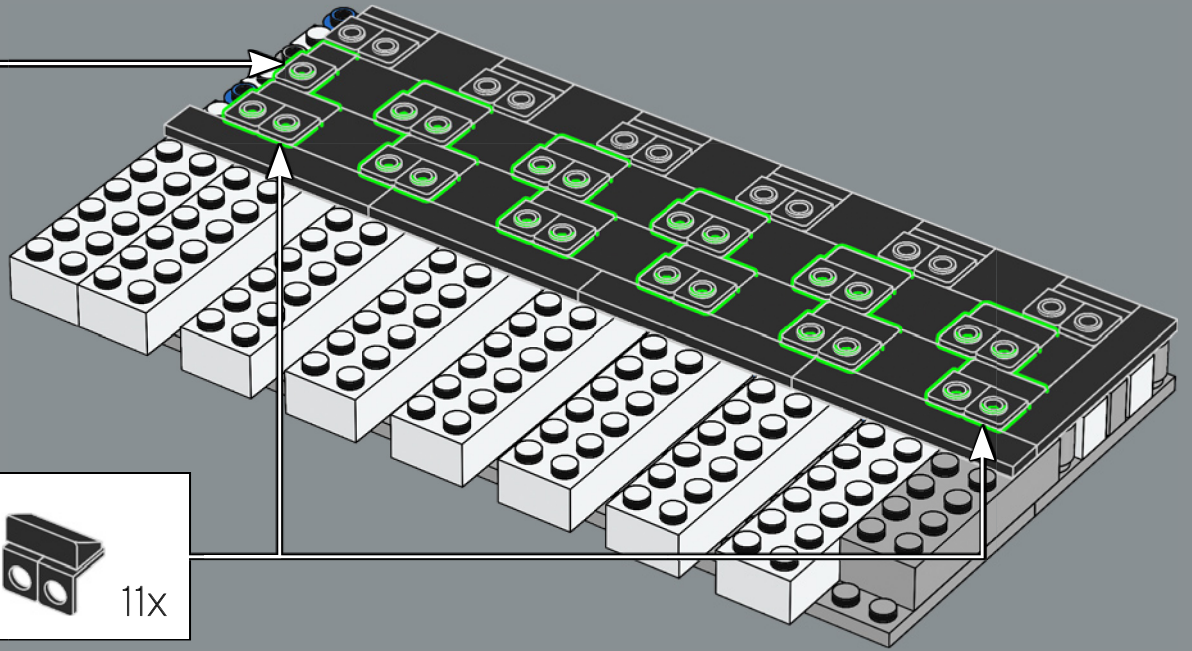
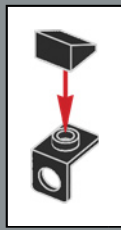

65

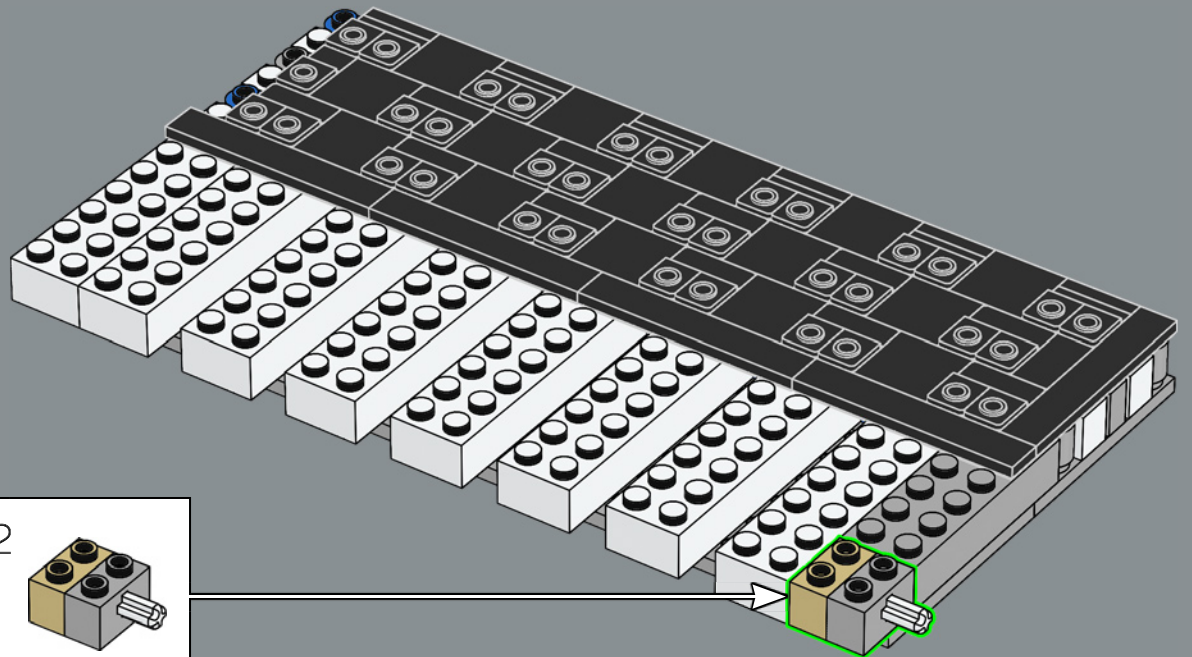
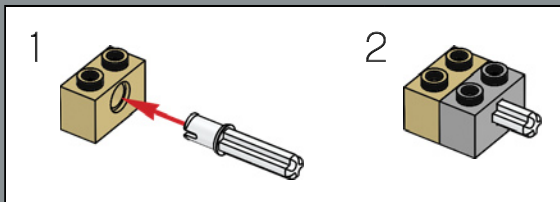

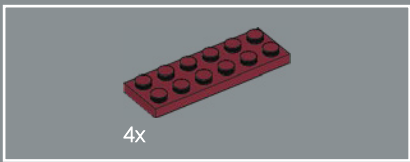

66

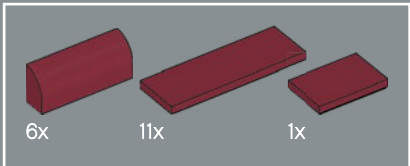
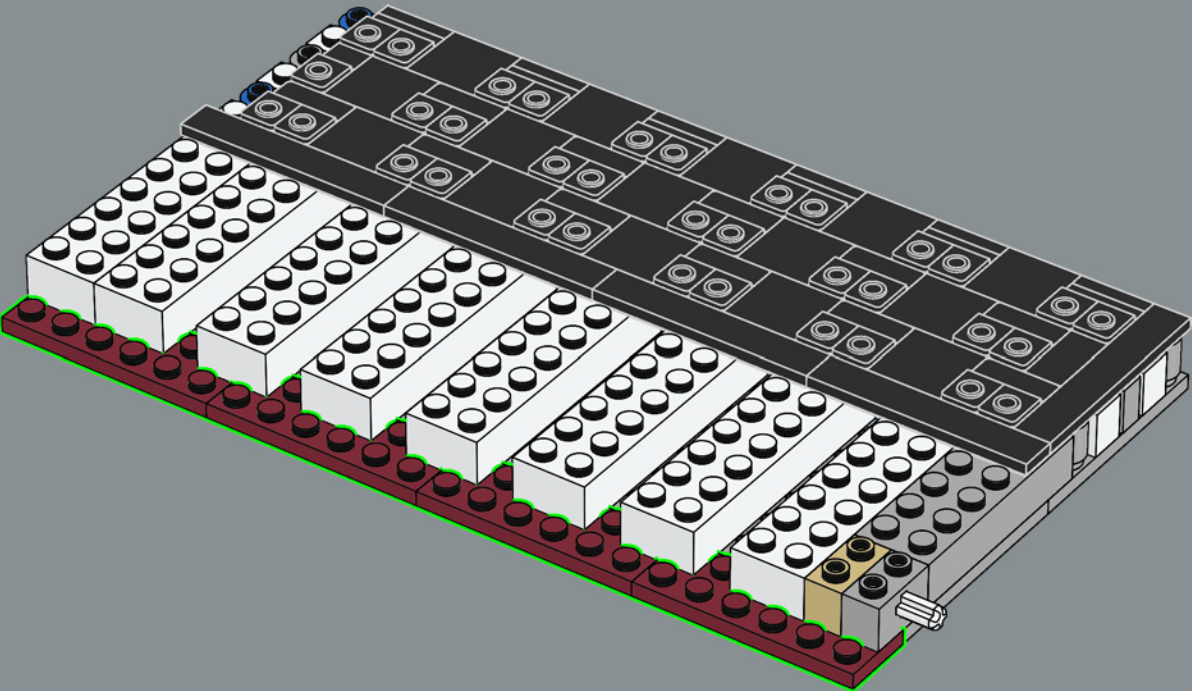

67

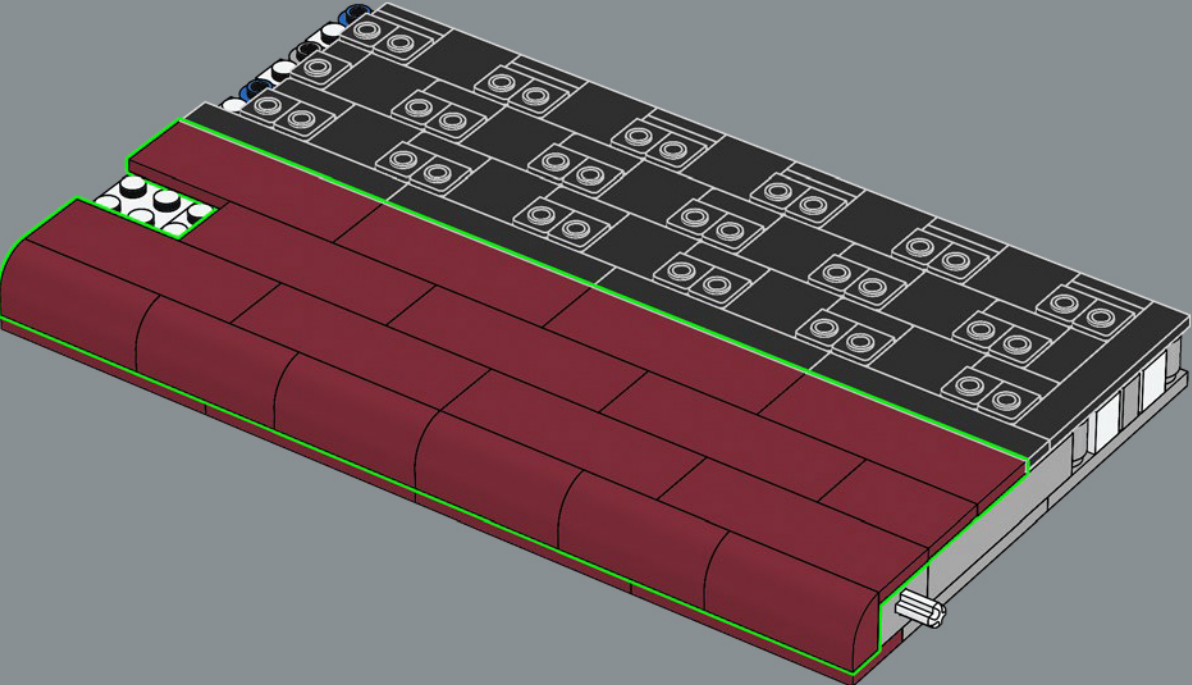

68

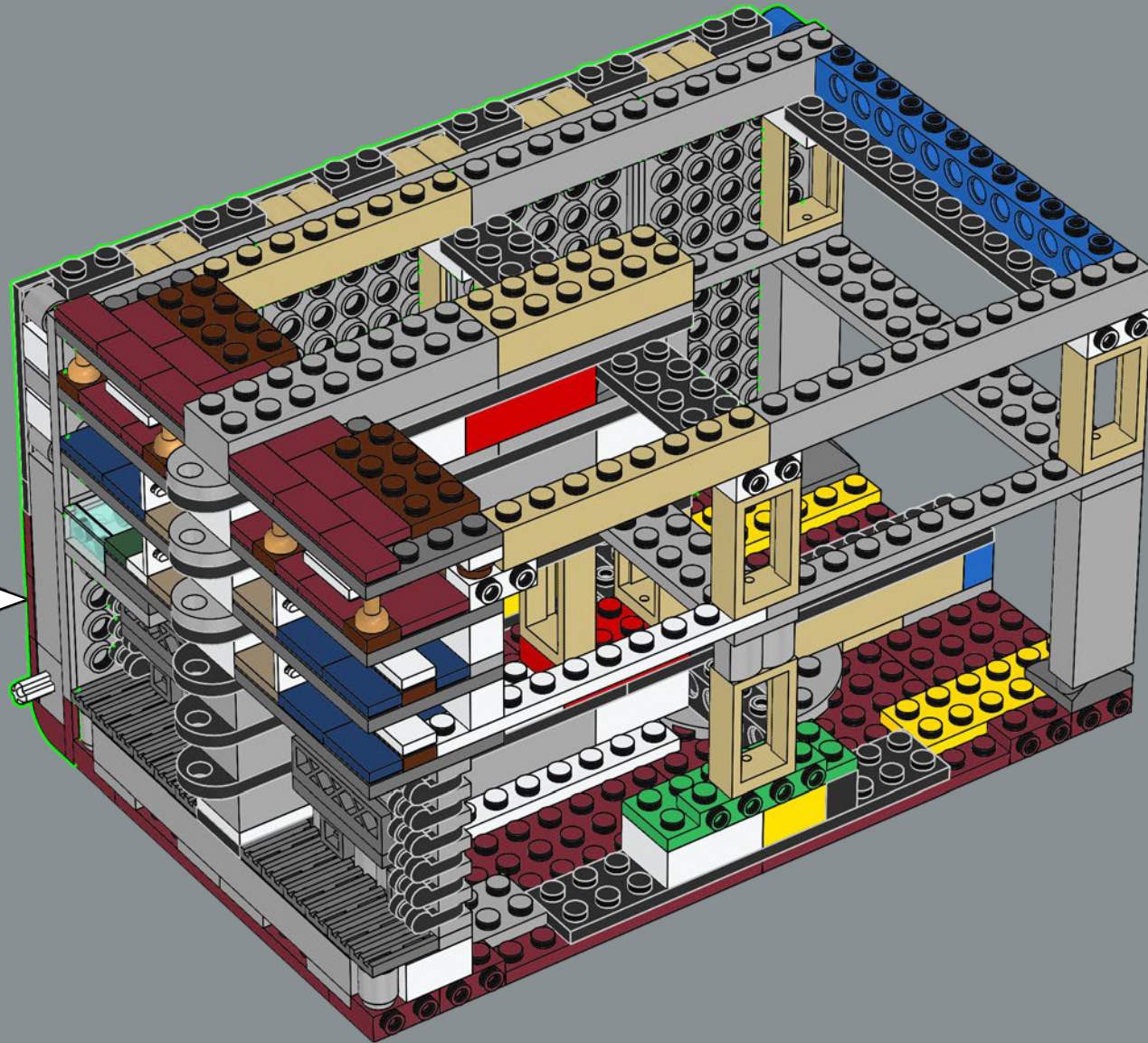

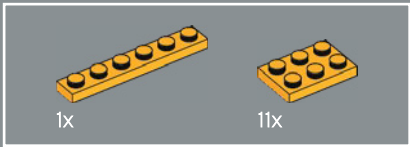

69

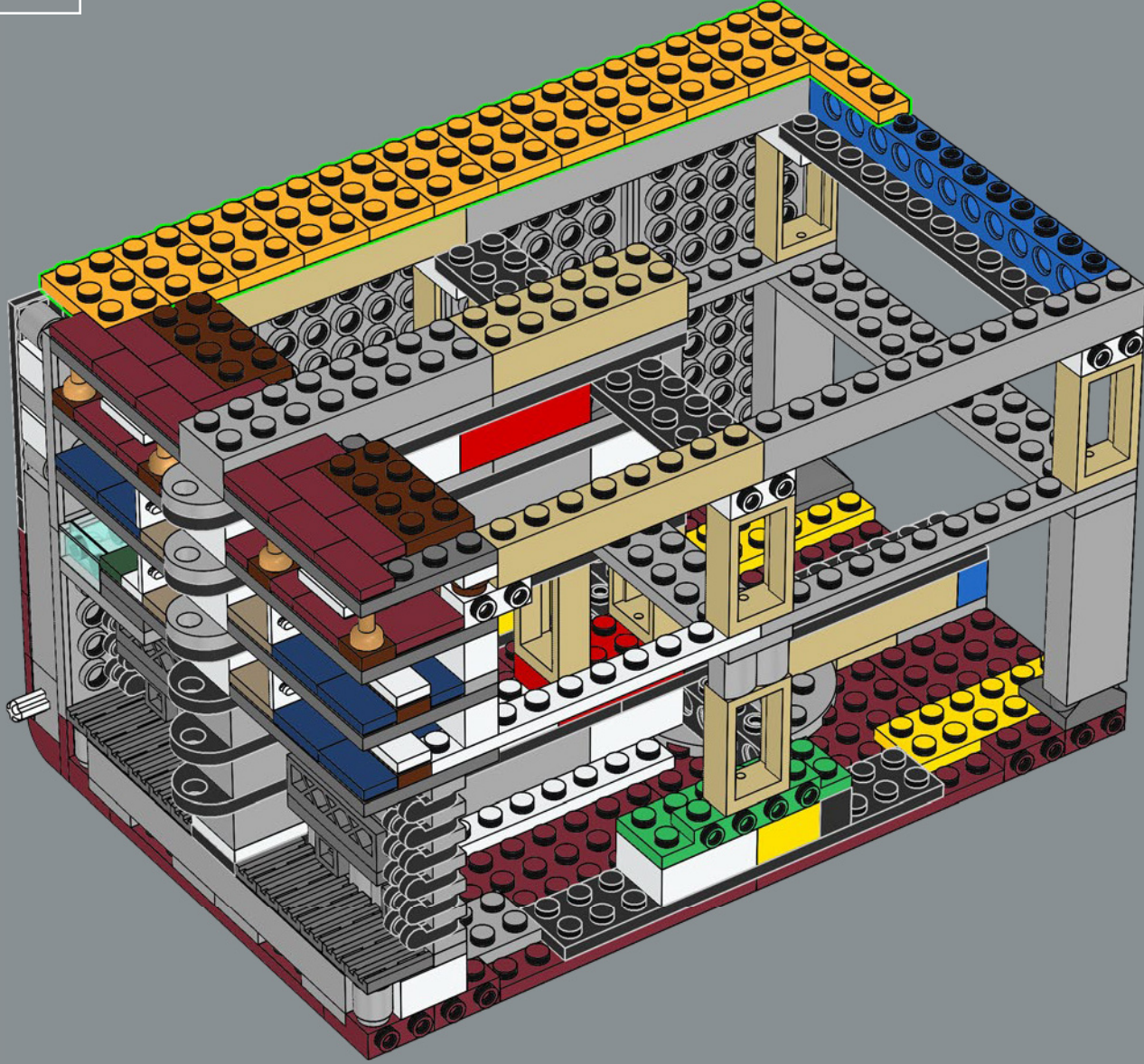

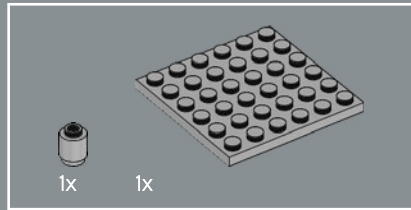
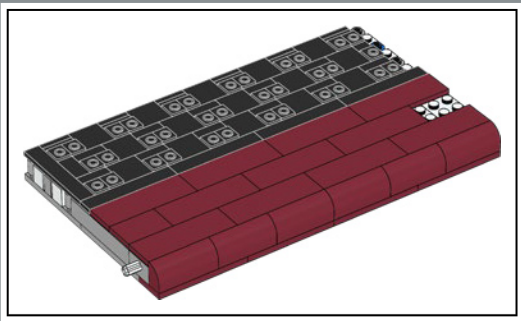
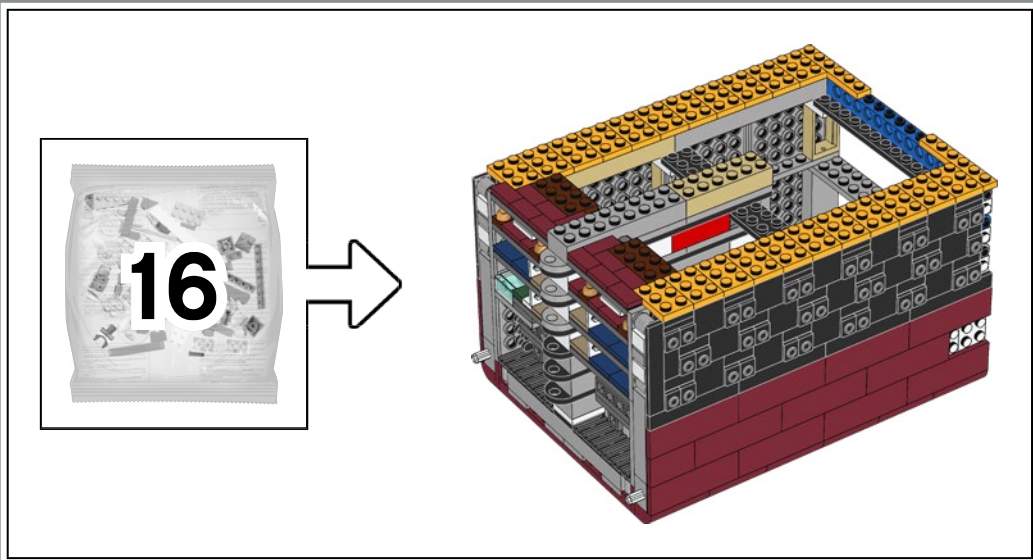

70

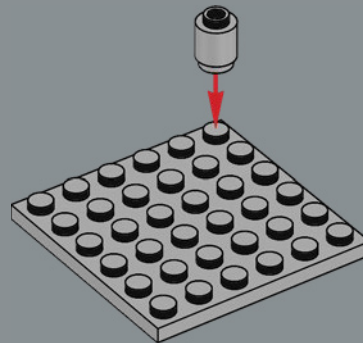

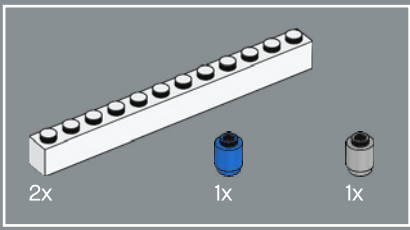

71

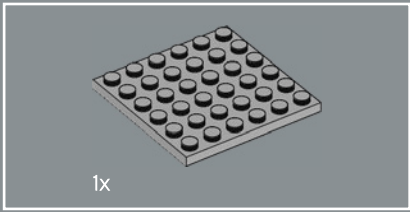
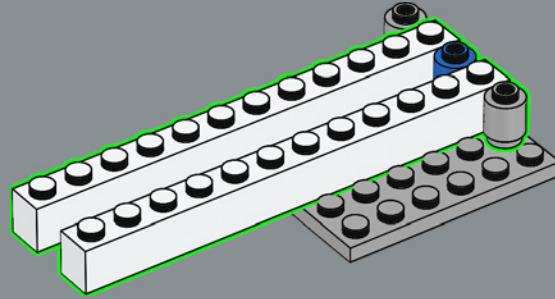

72

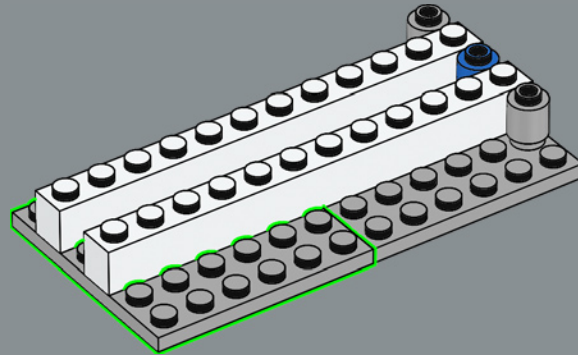

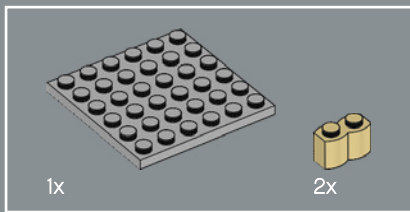

73

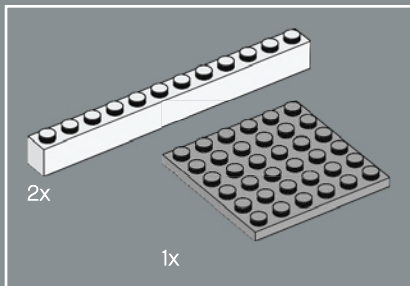
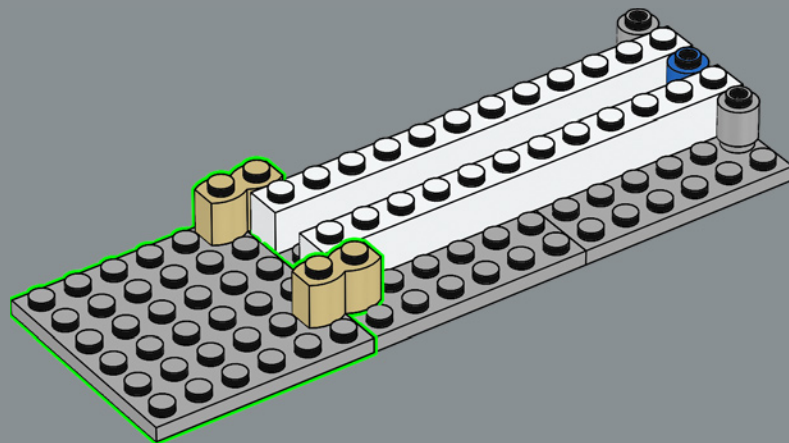

74

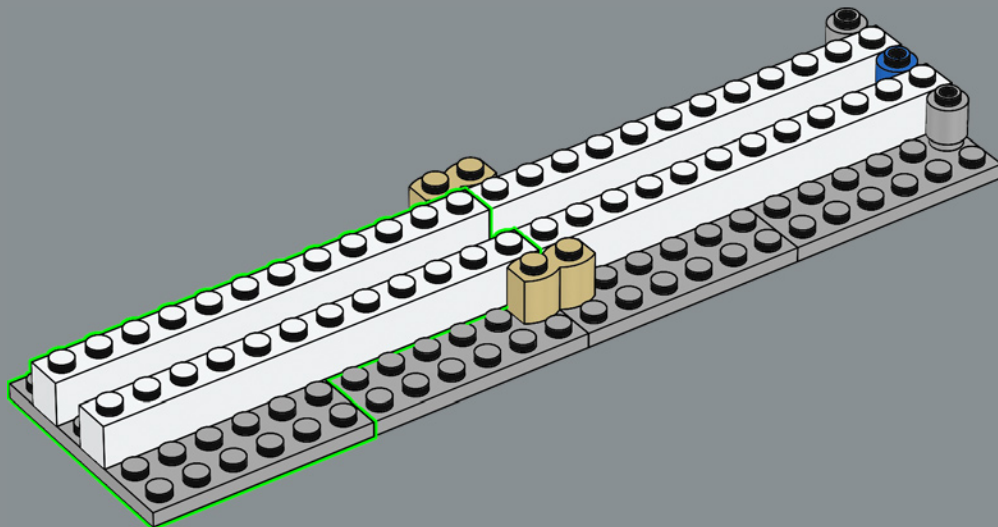

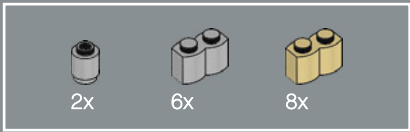

75

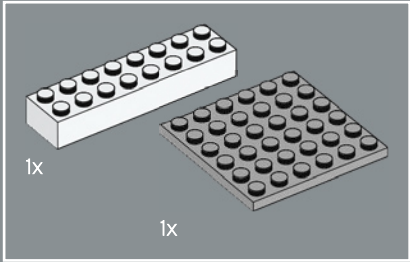
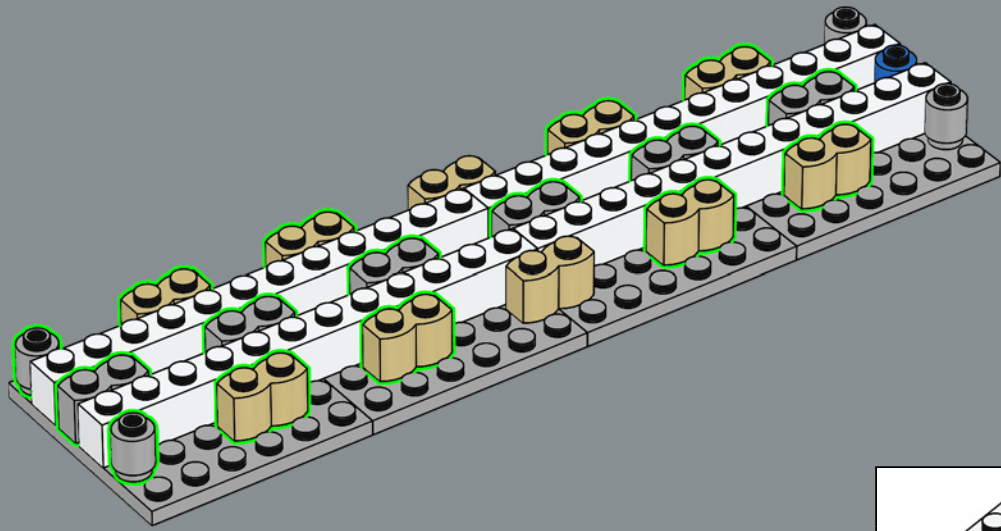

76

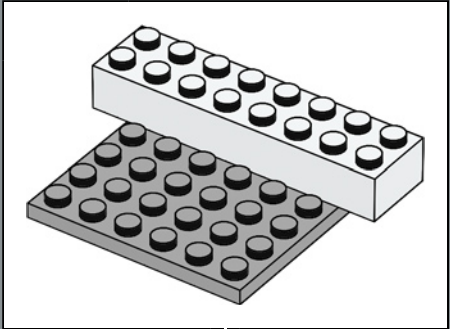
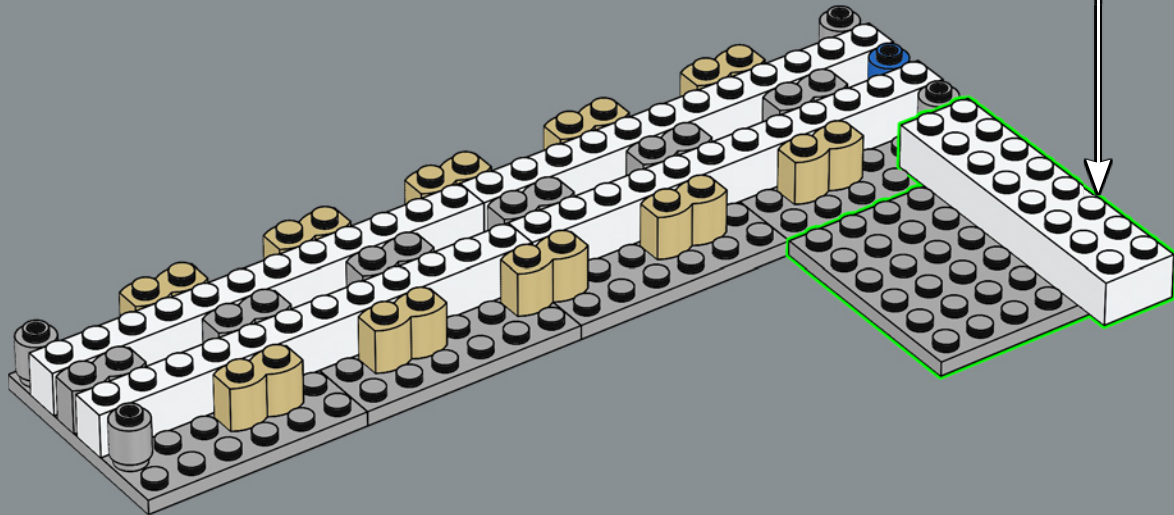



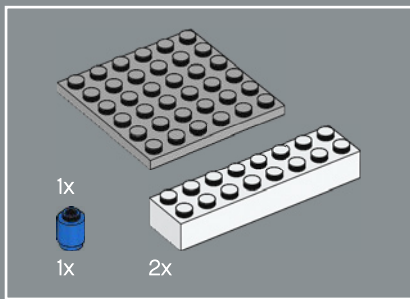

77

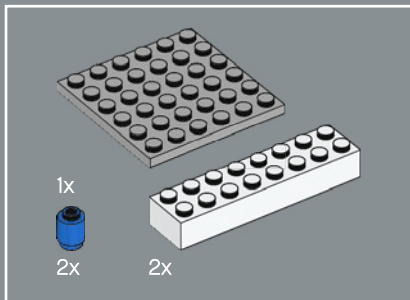
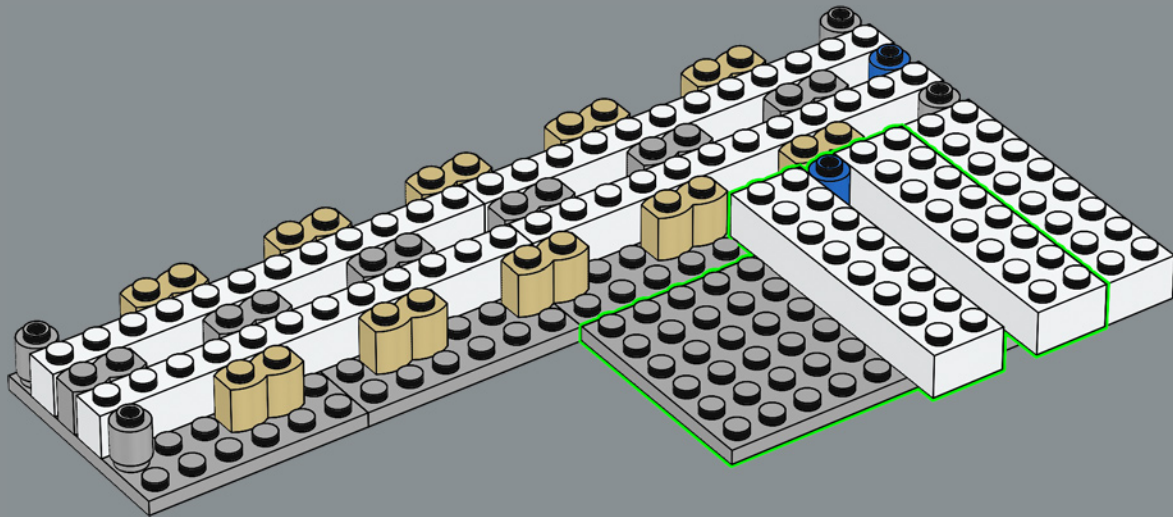

78

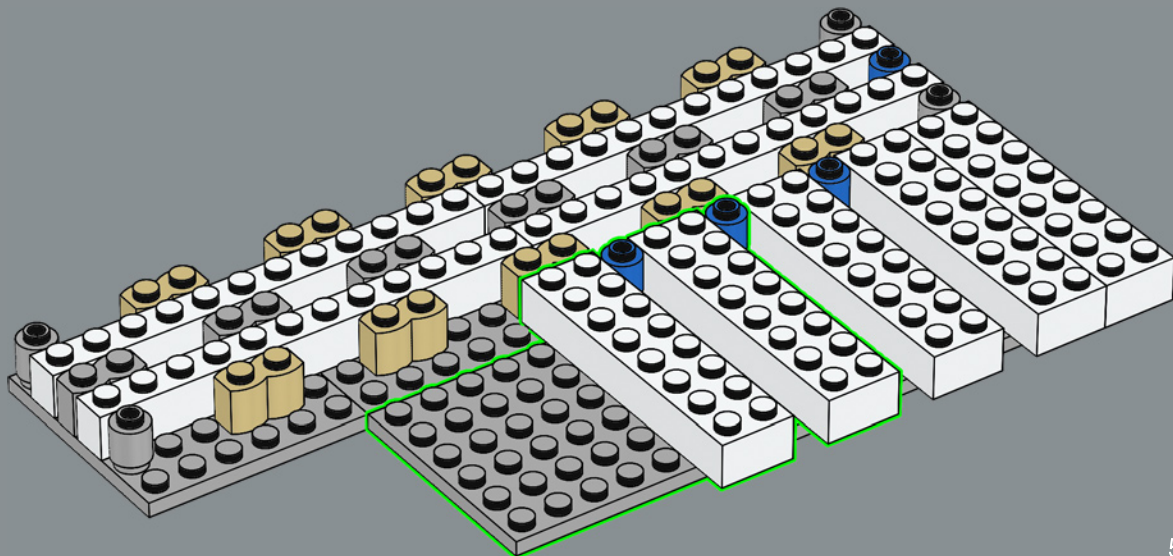

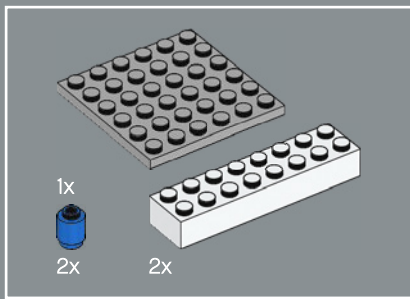

79

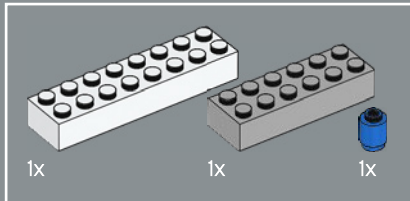
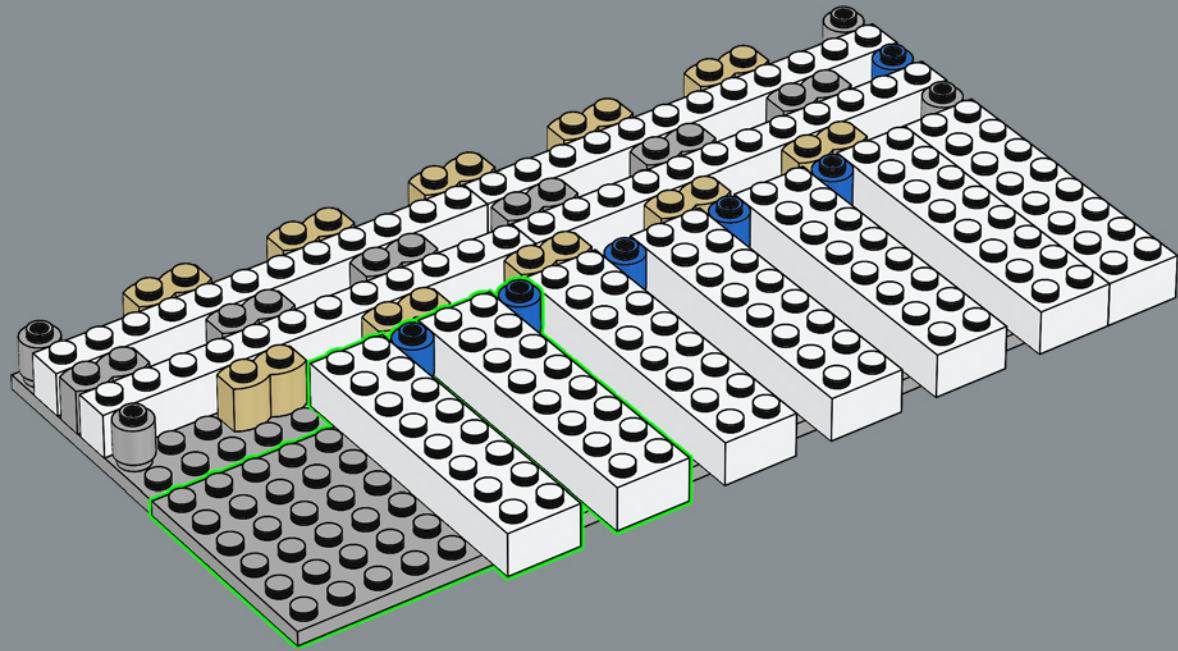

80

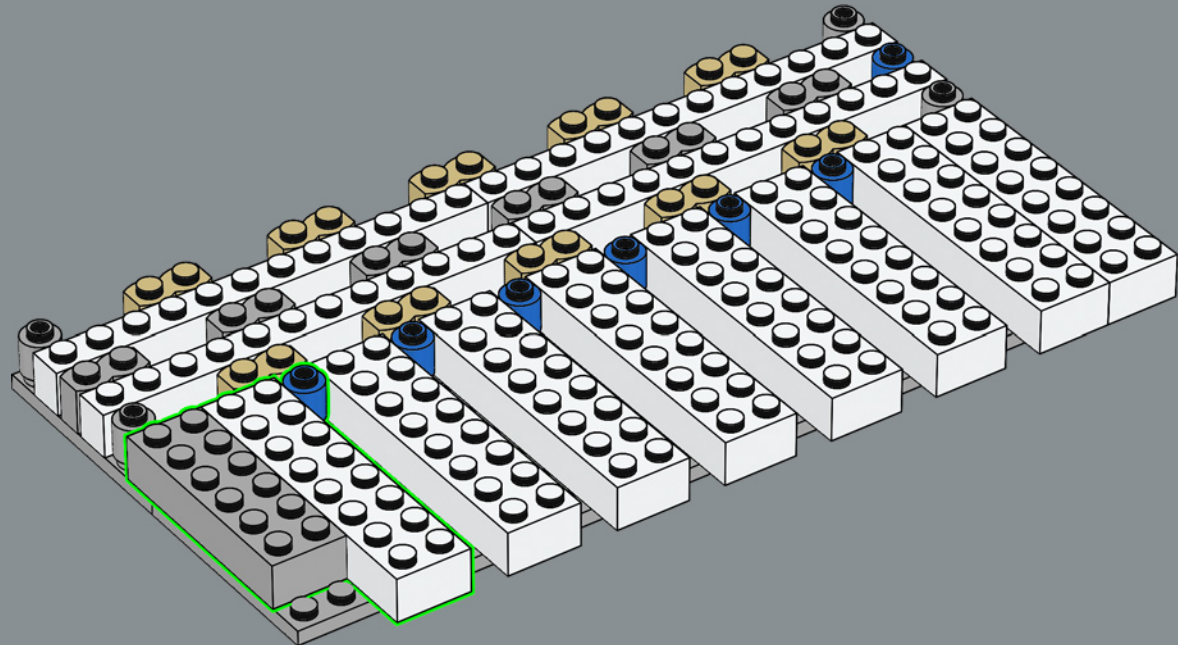

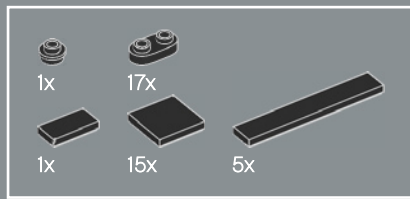

81

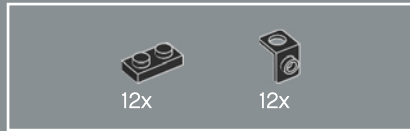
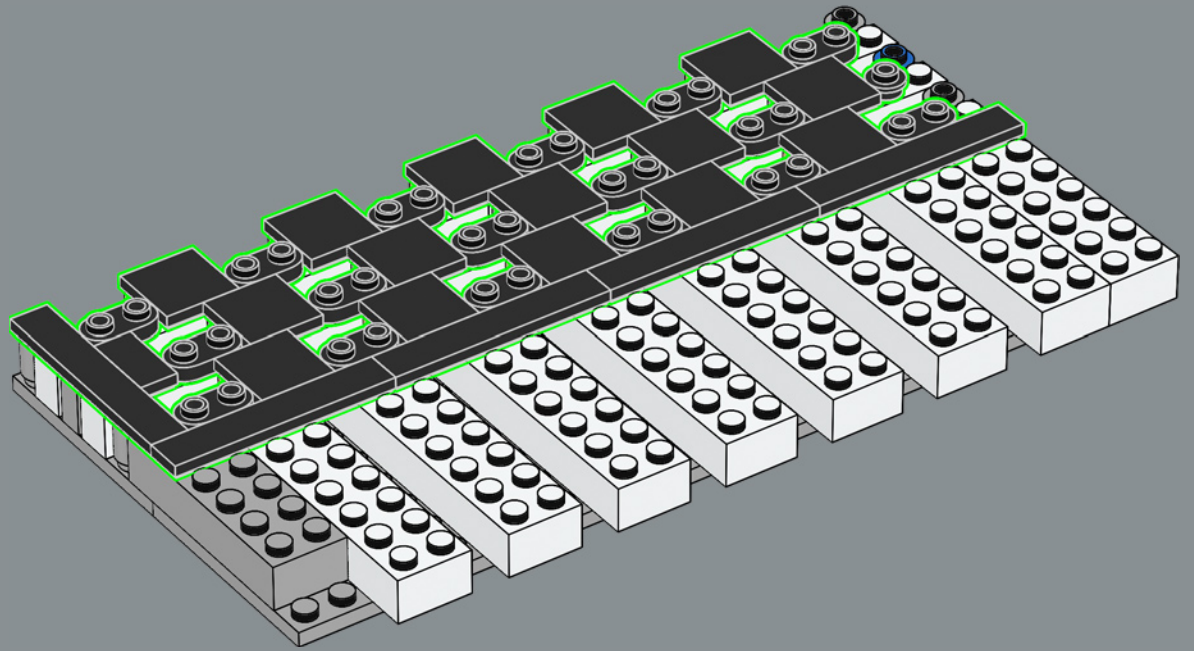

82

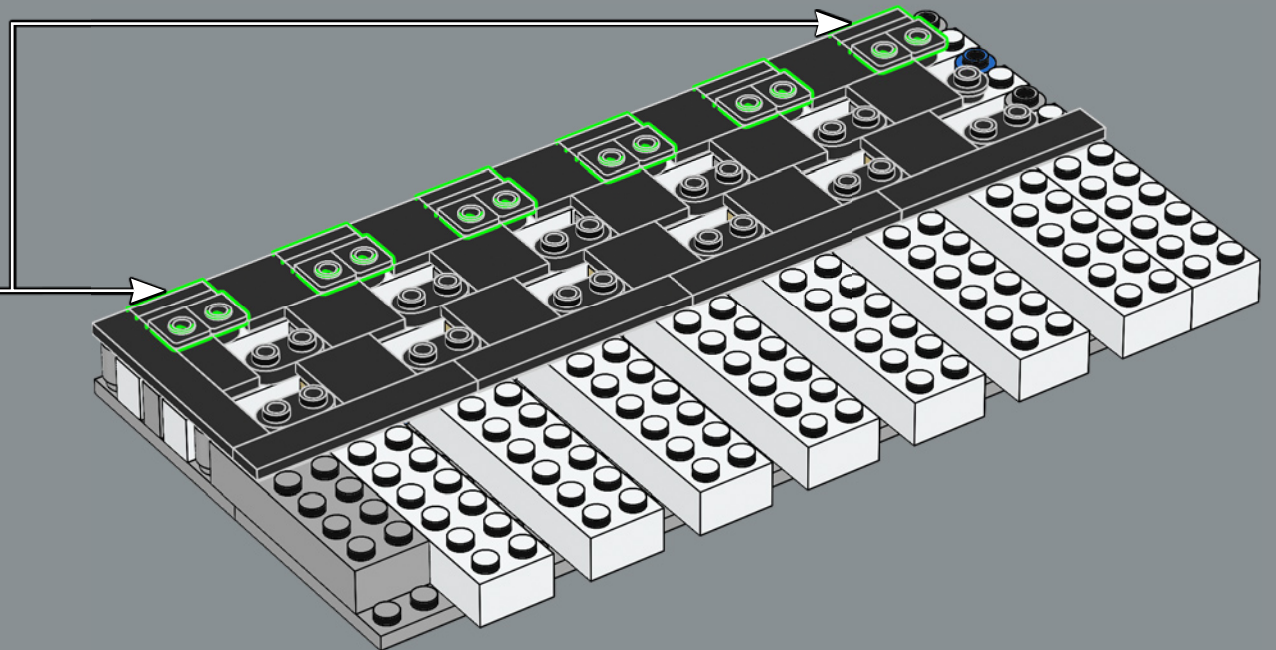
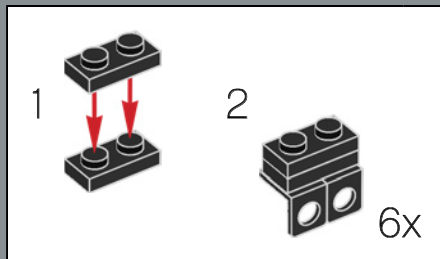



83

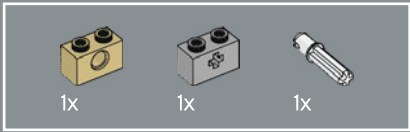
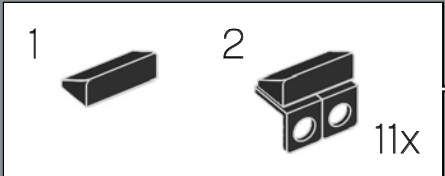
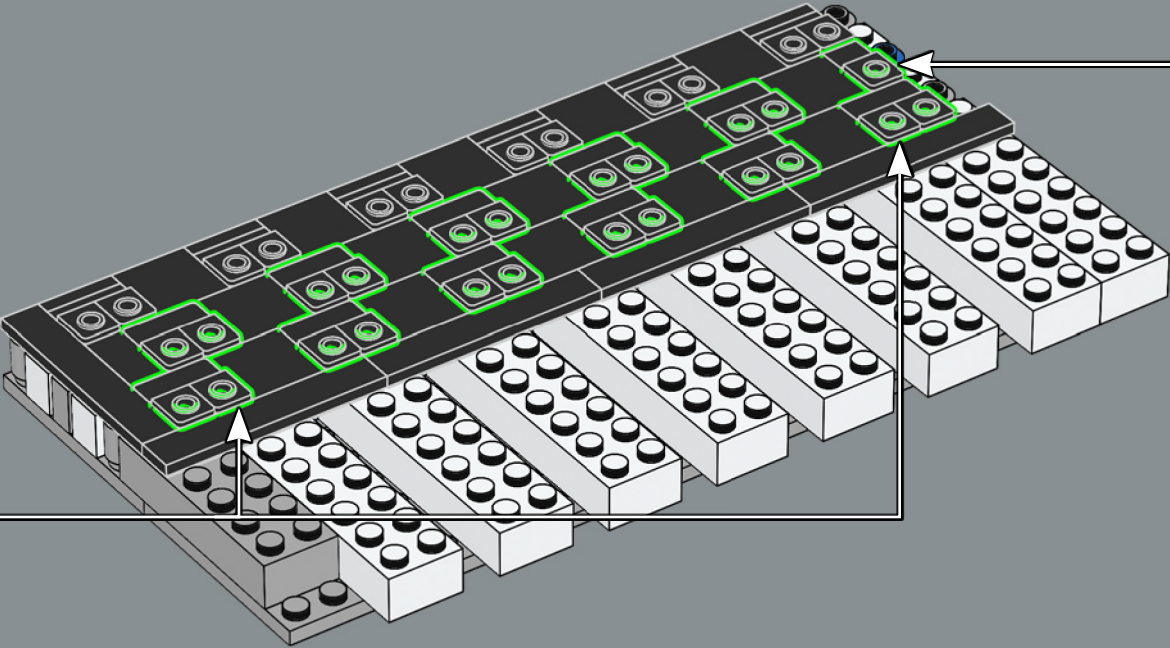
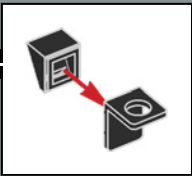

84

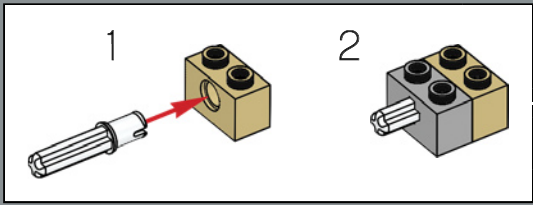
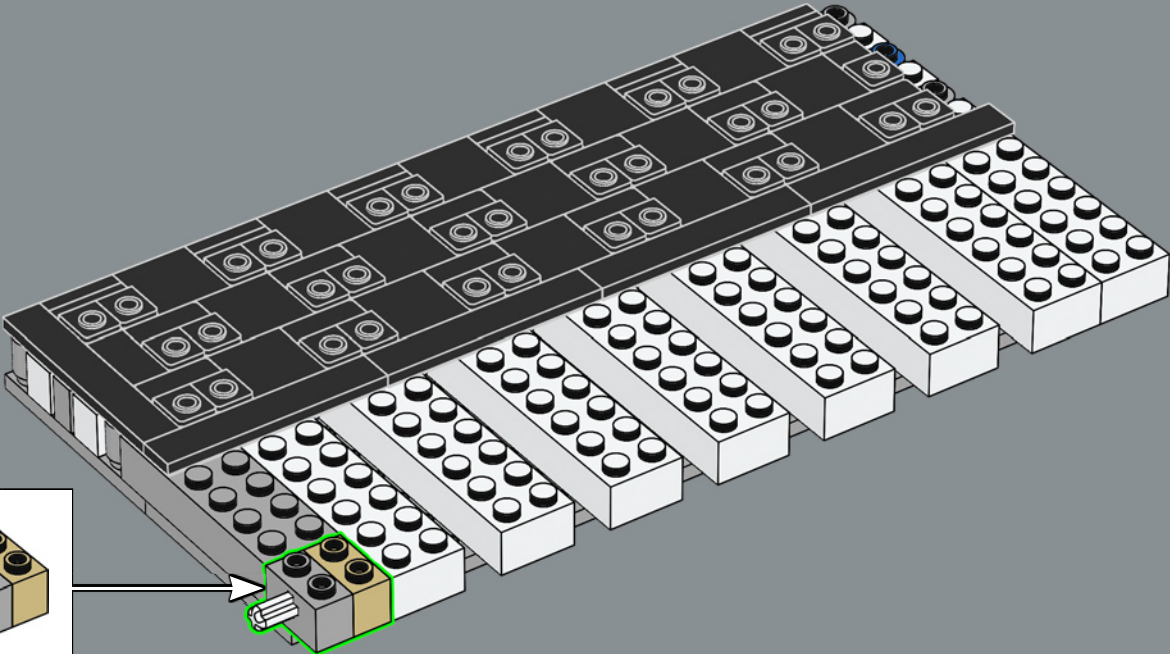

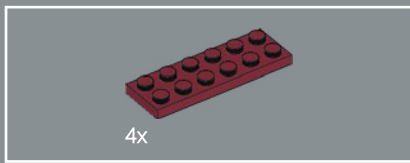

85

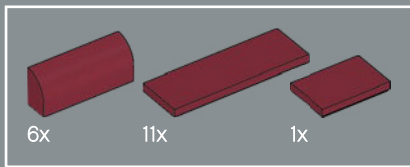
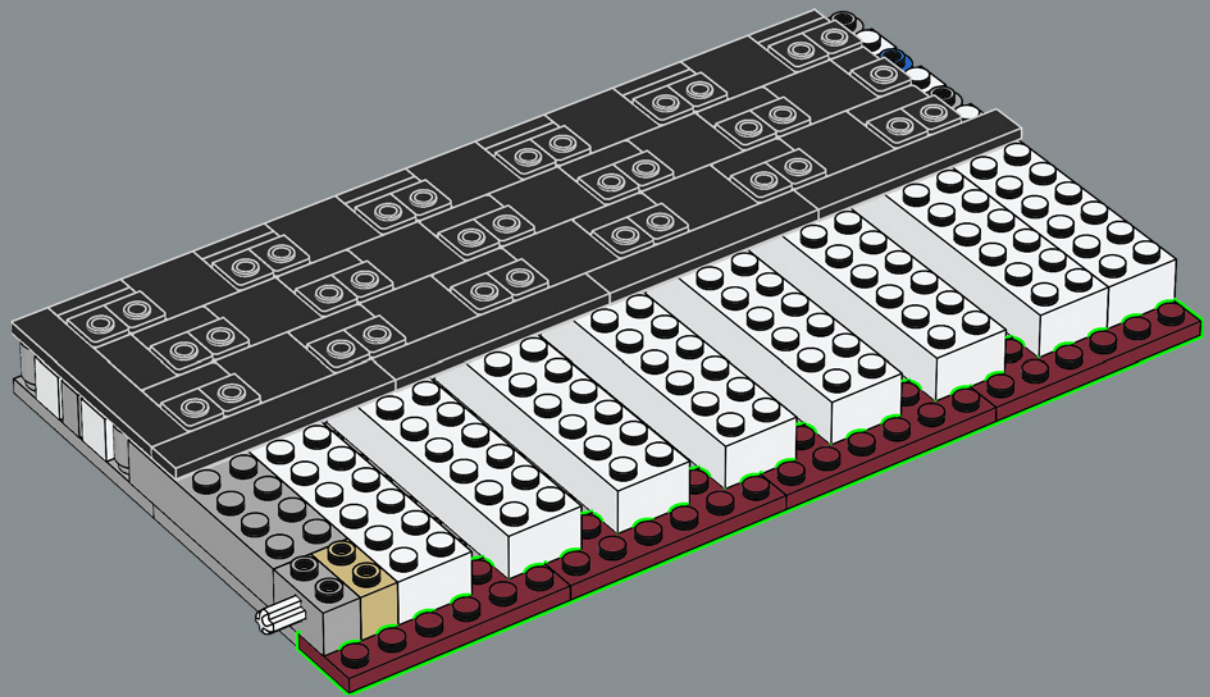

86

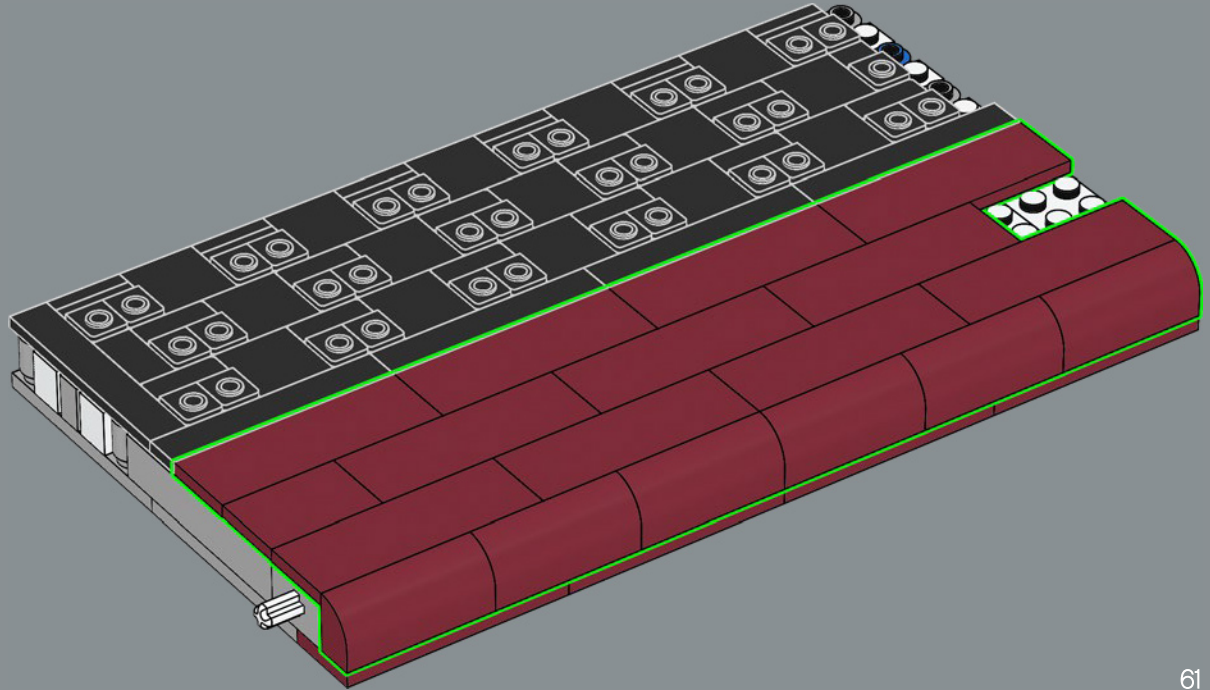

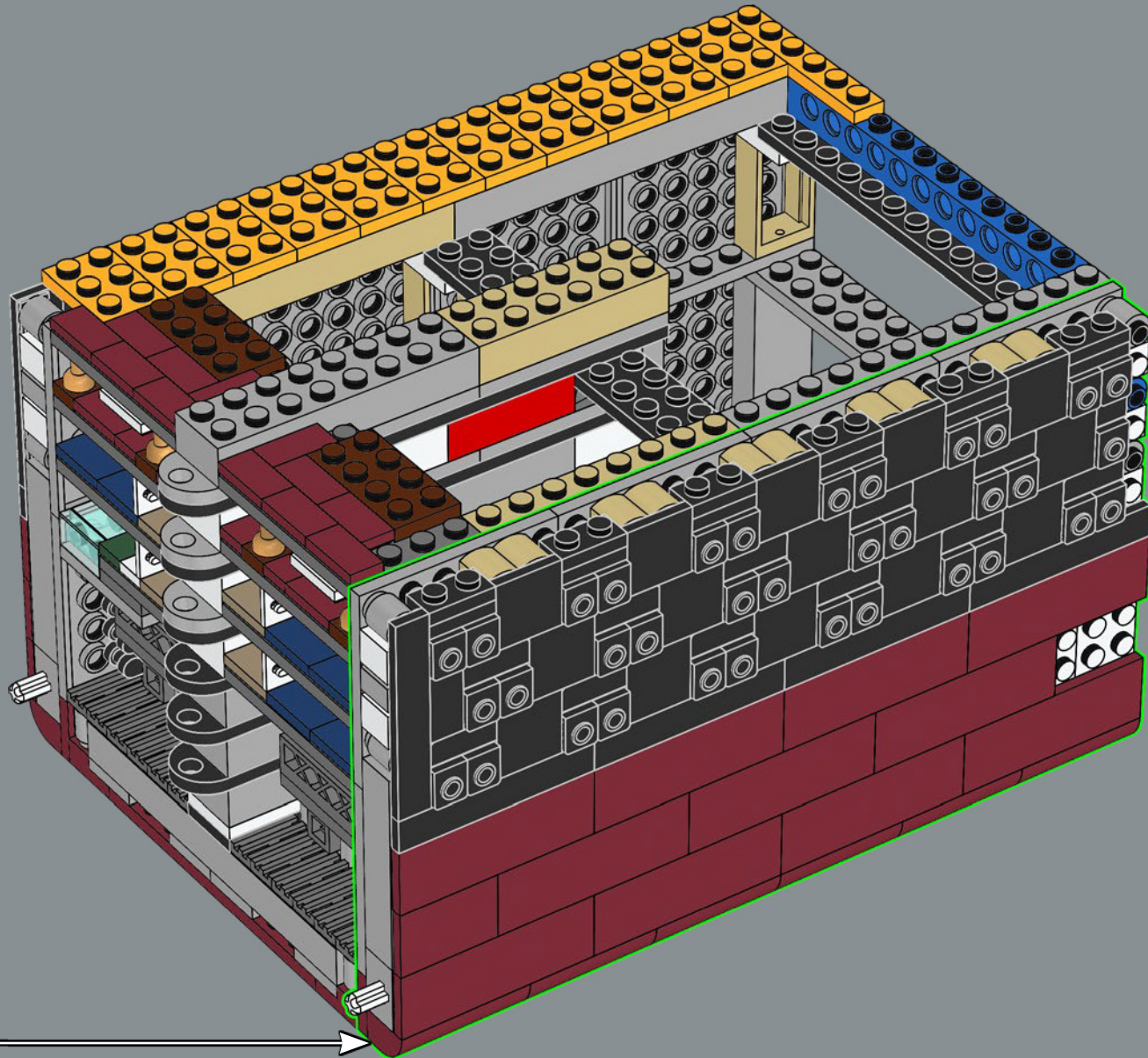

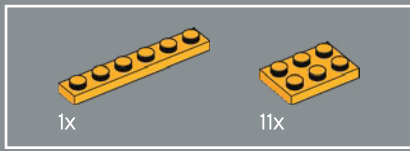

88

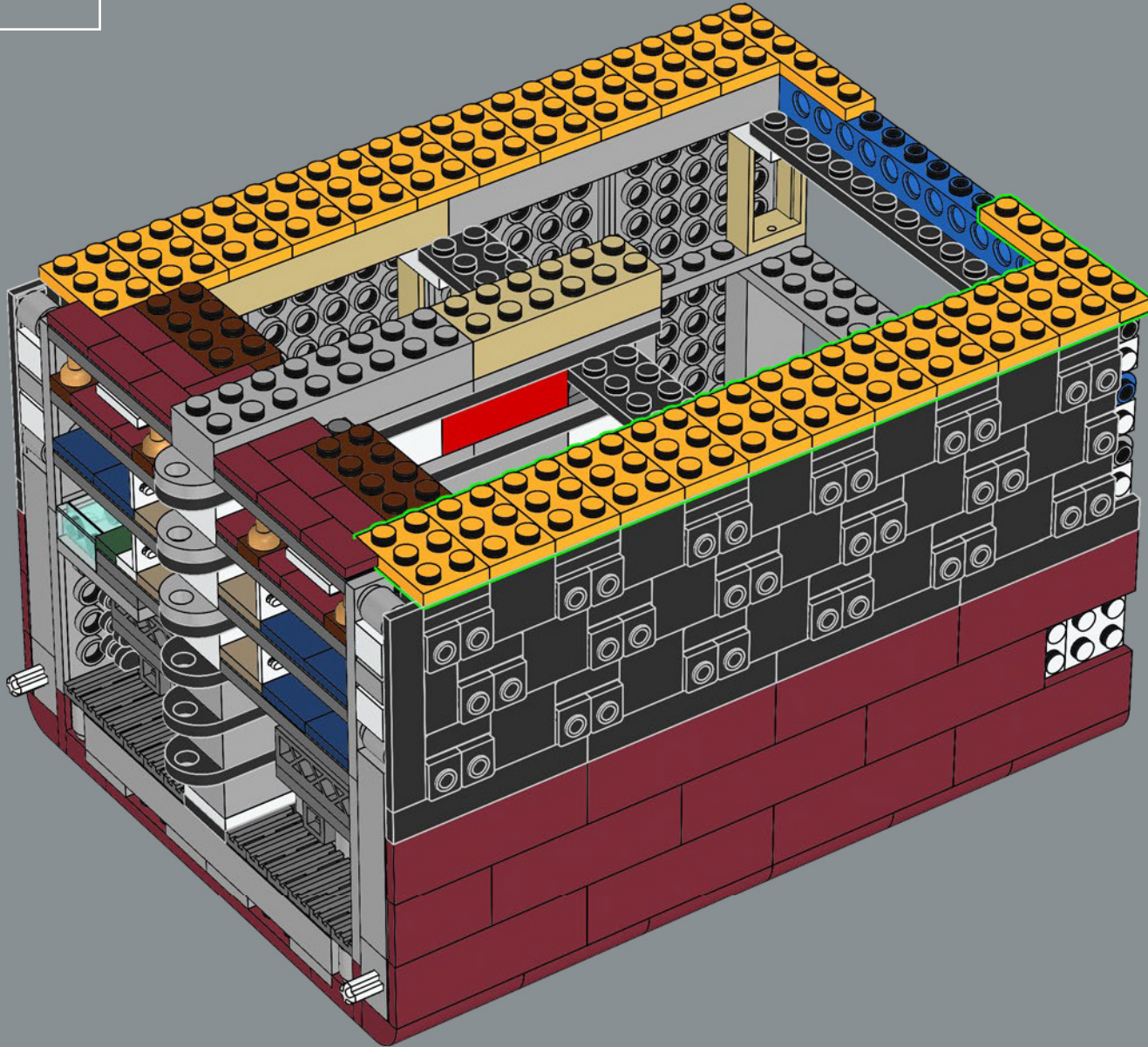

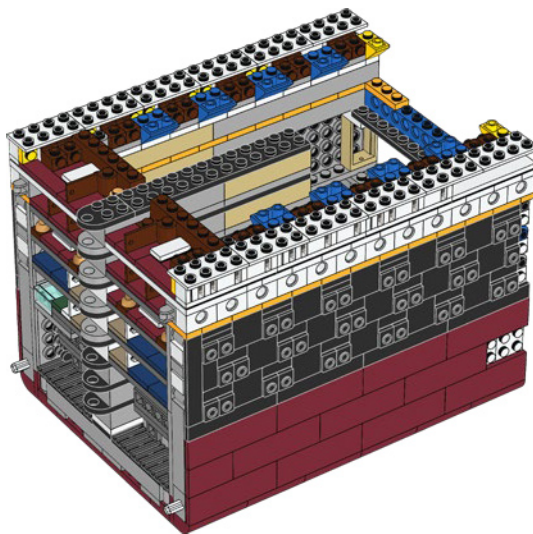
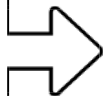



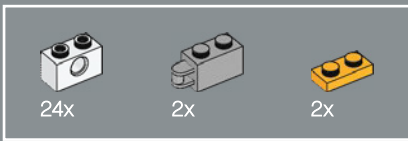

89

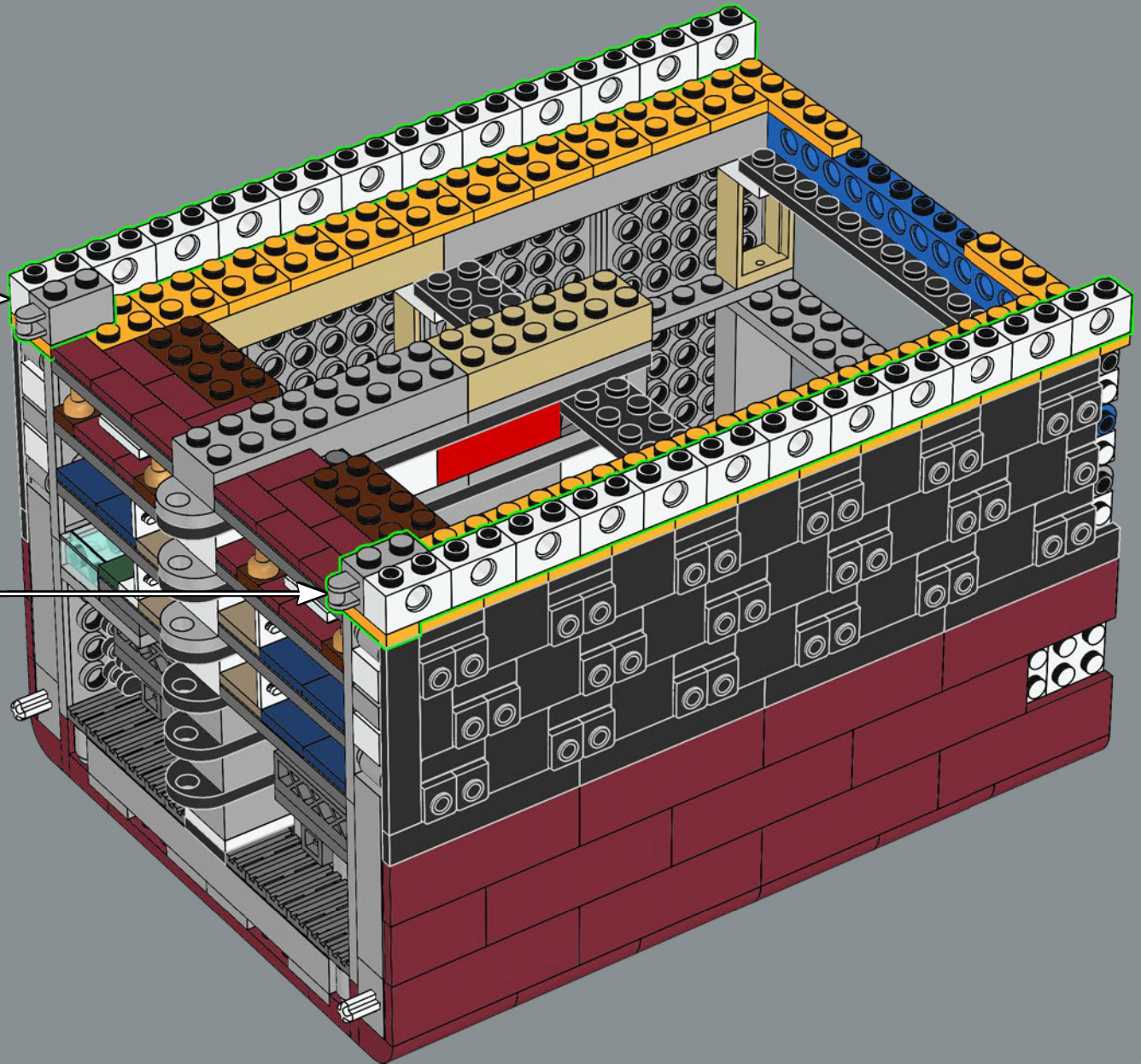
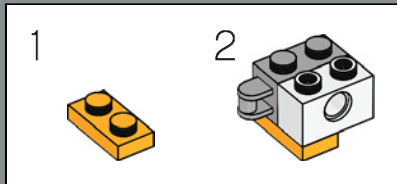
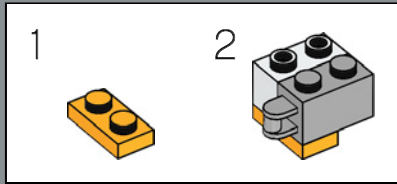

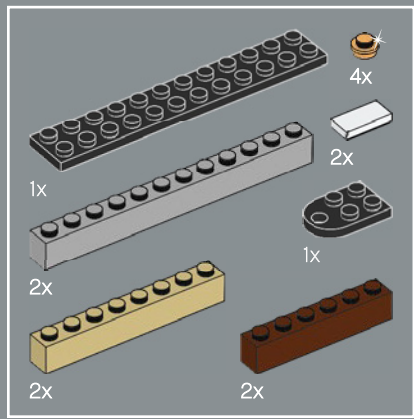

90

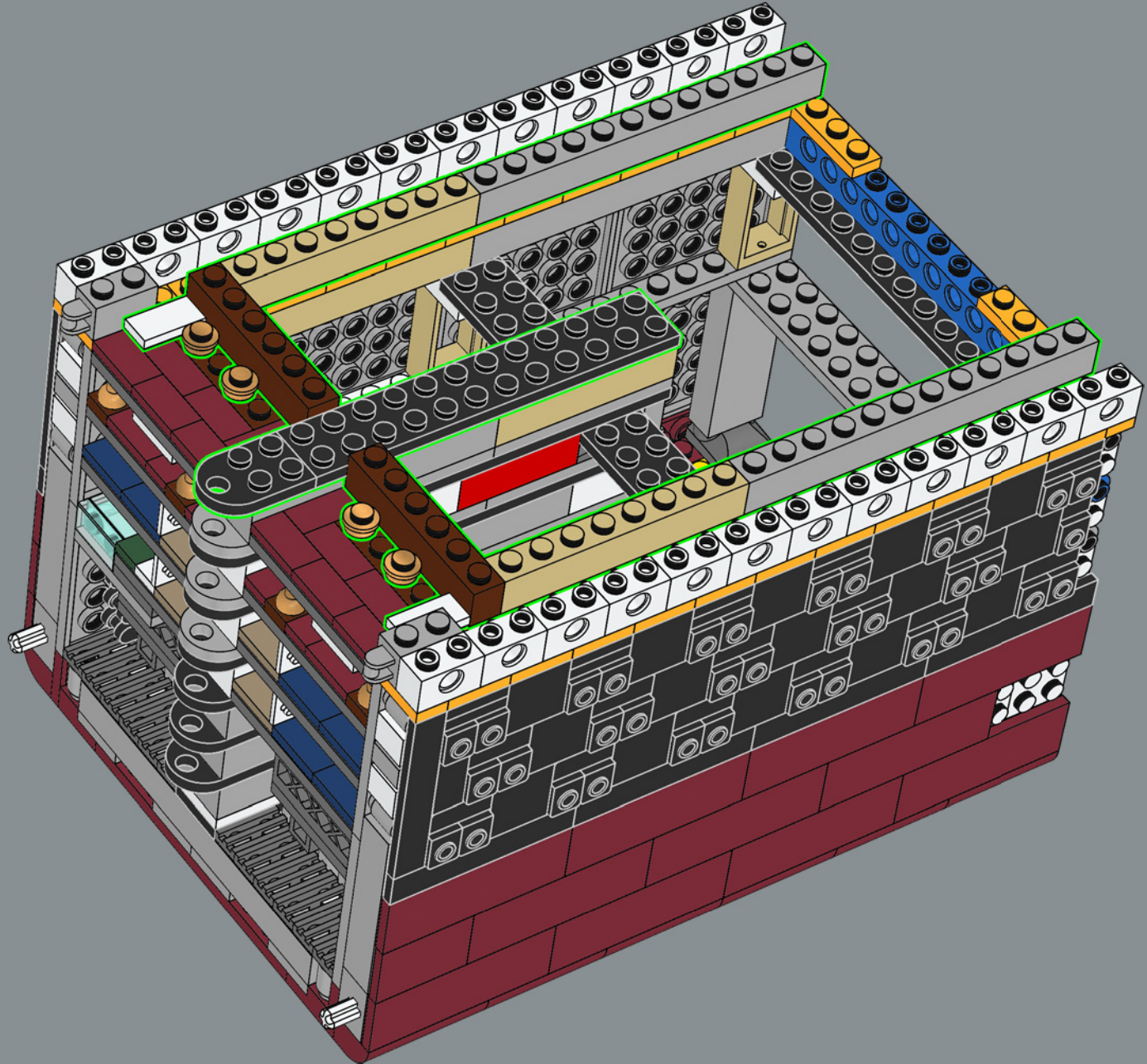

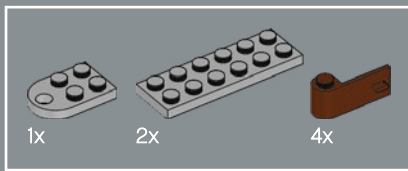

91

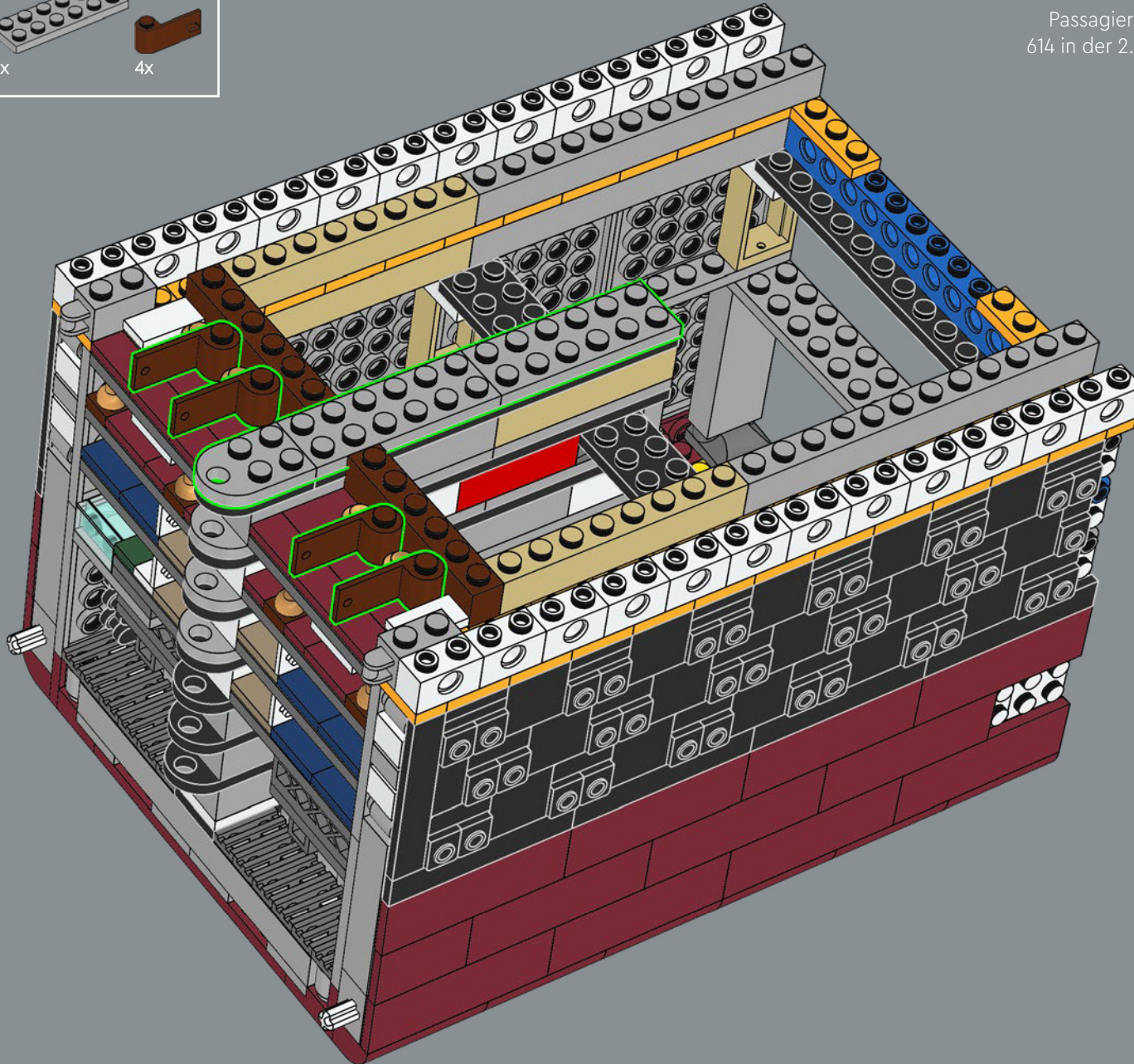

Die *Titanic* konnte insgesamt 2.453  
Passagiere befördern – 833 in der 1. Klasse,  
614 in der 2. Klasse und 1.006 in der 3. Klasse.

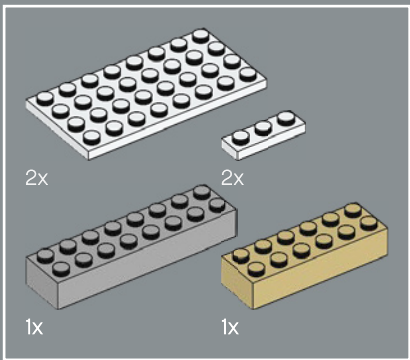

92

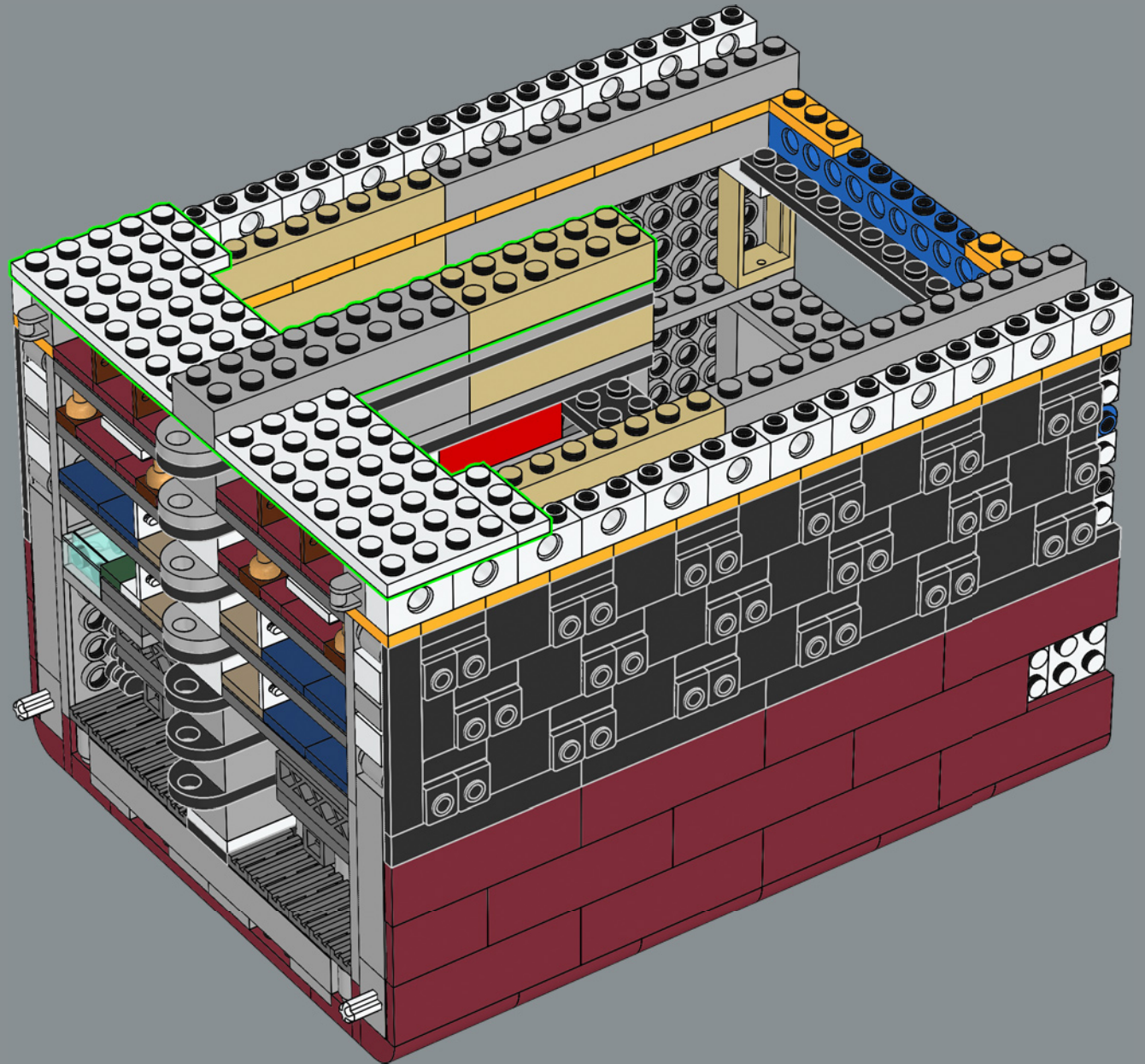

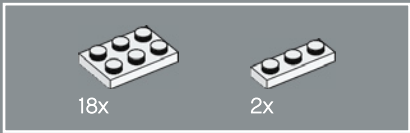

93

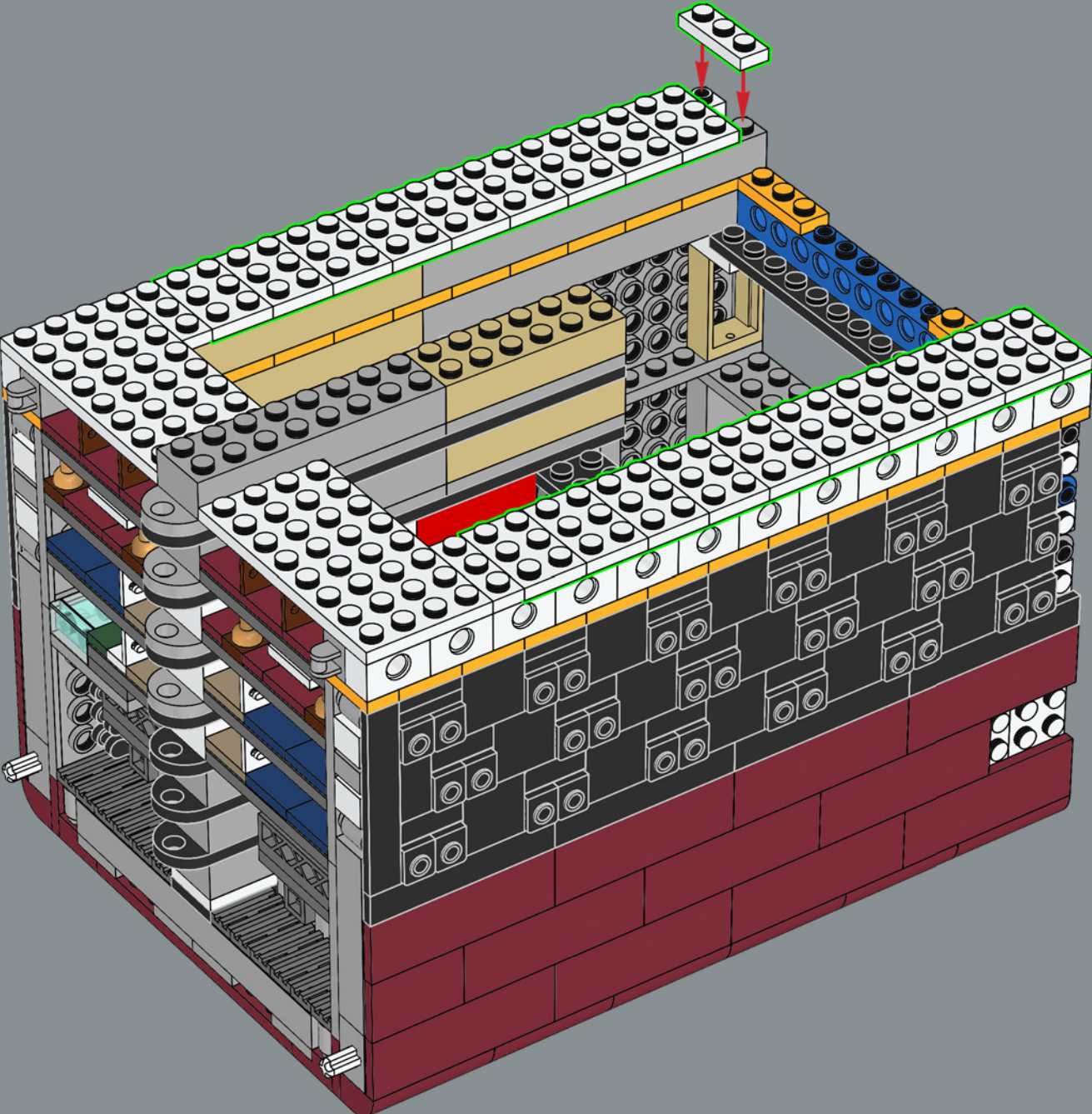

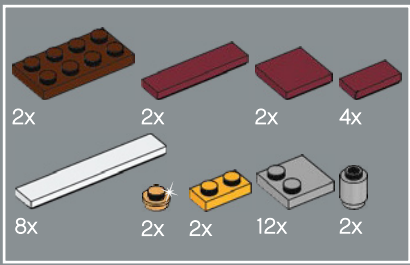

94

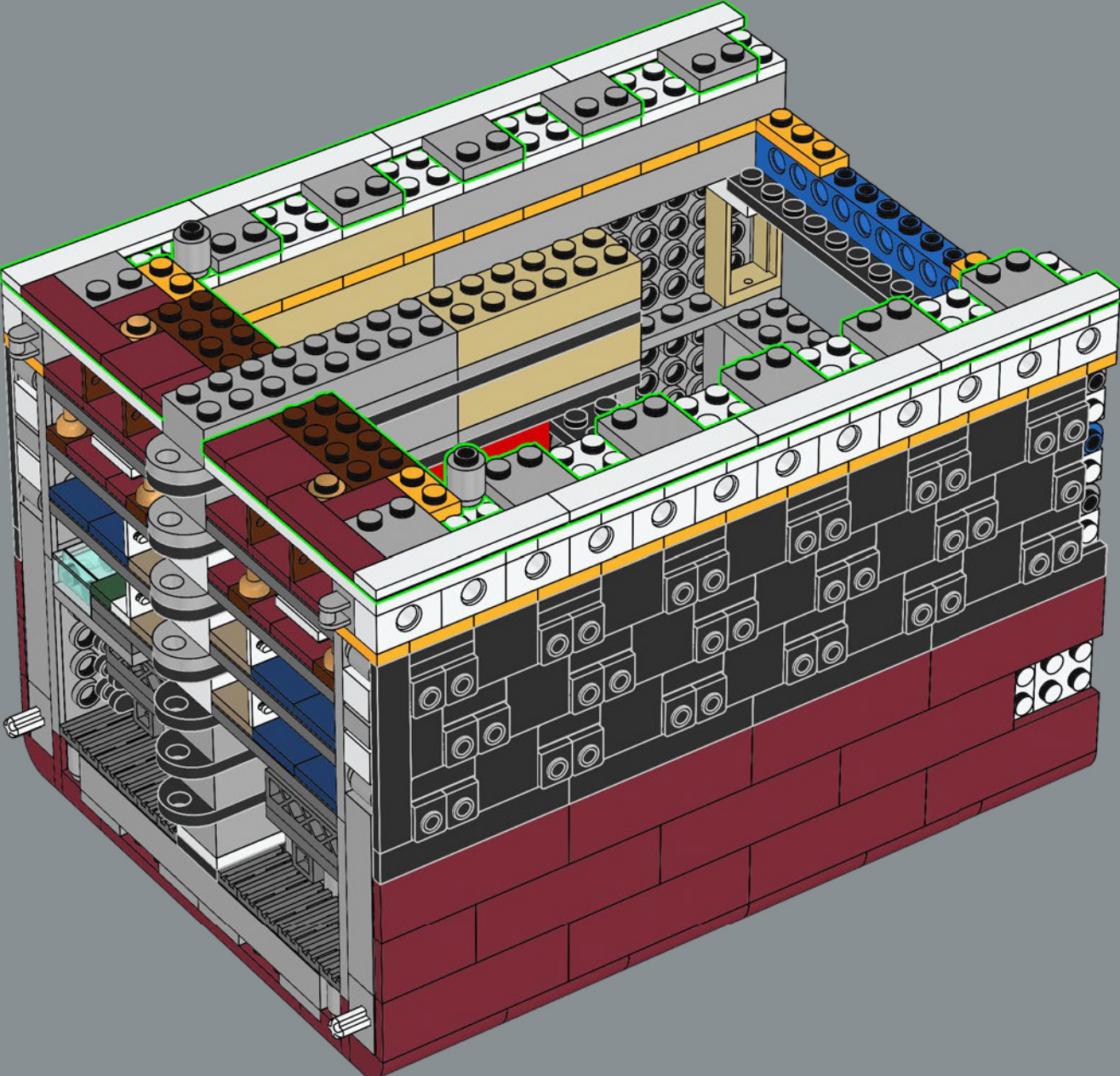

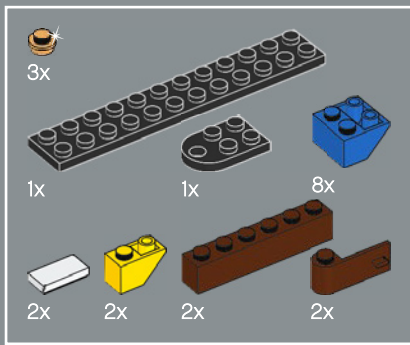

95

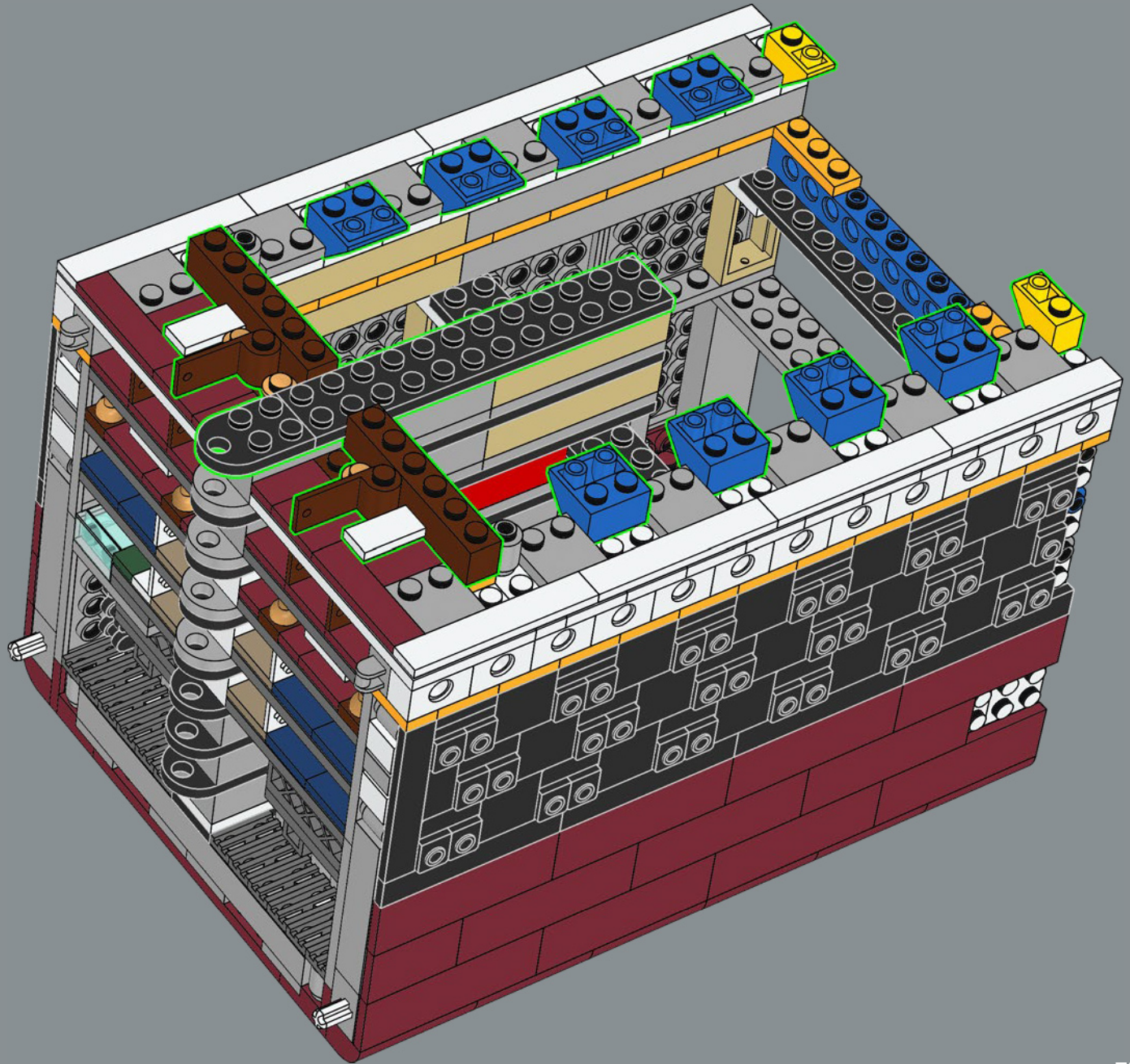

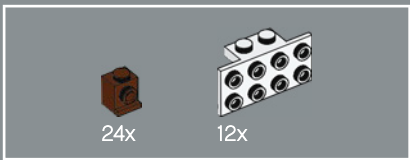

96

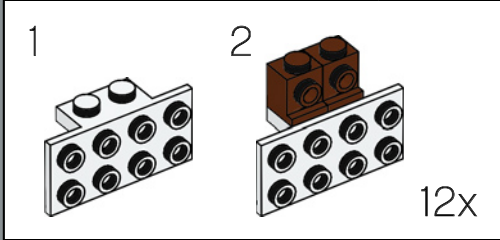
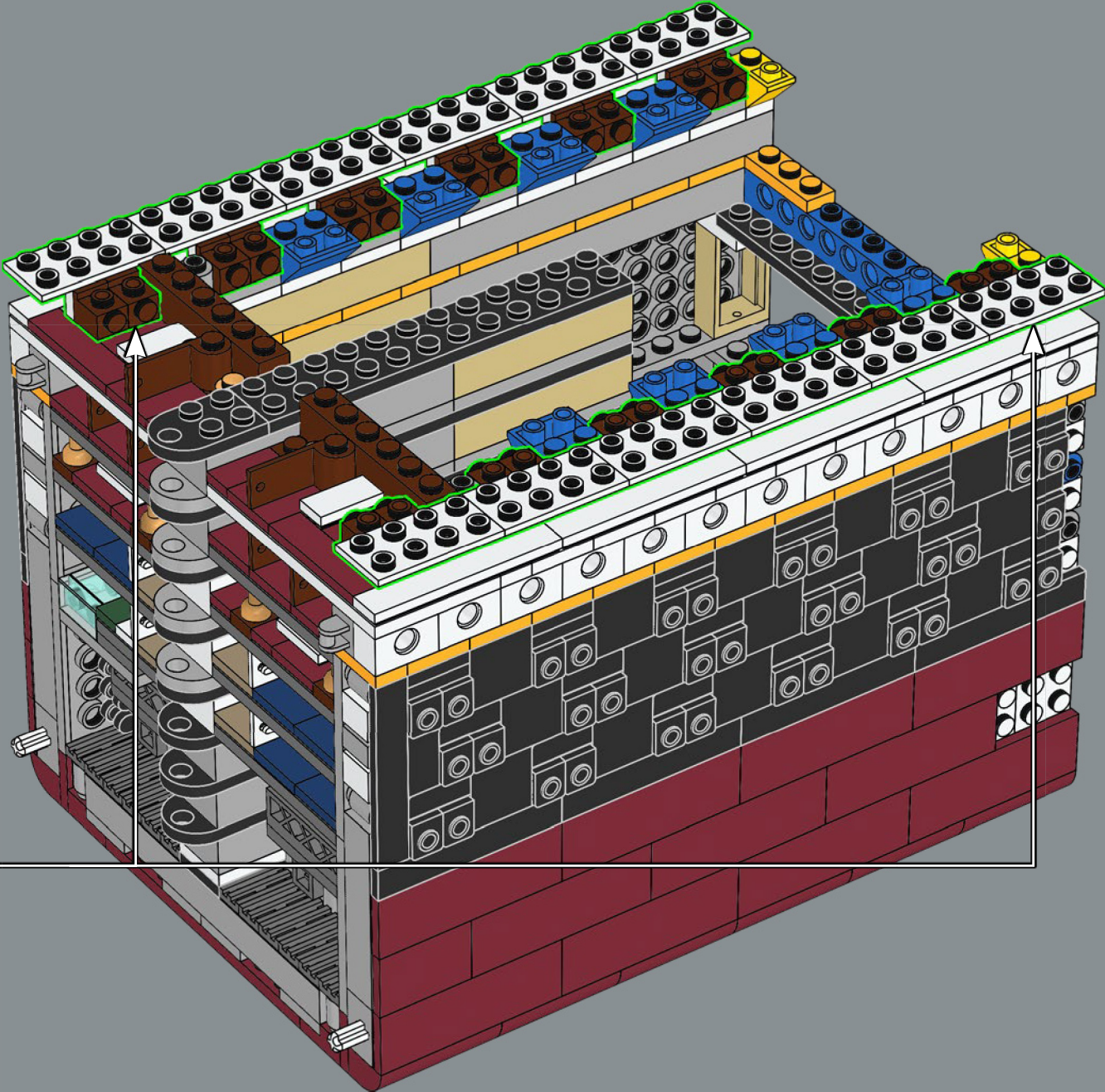



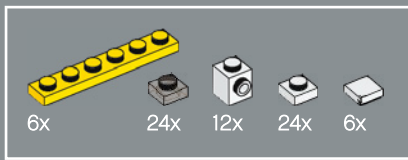

97

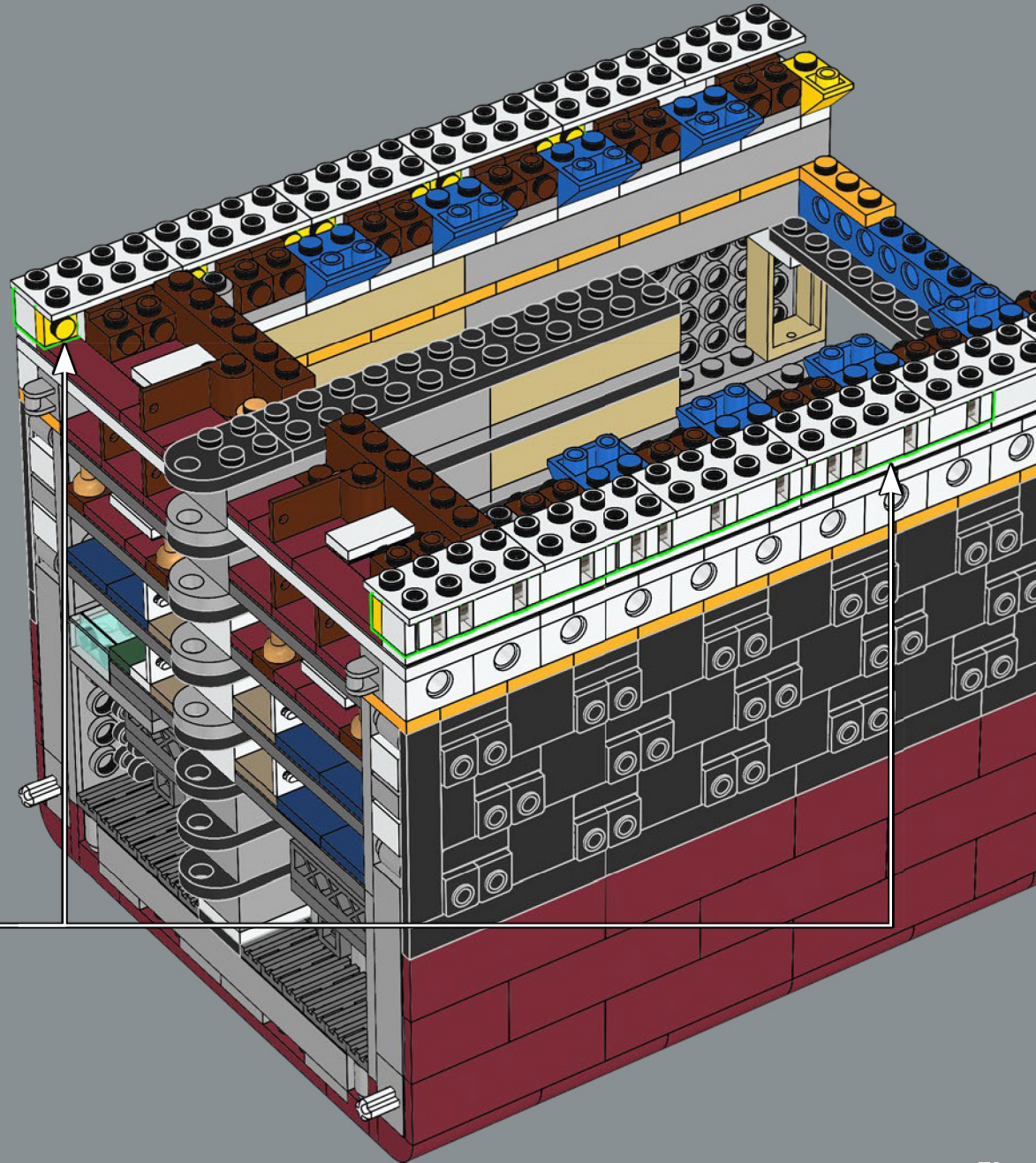
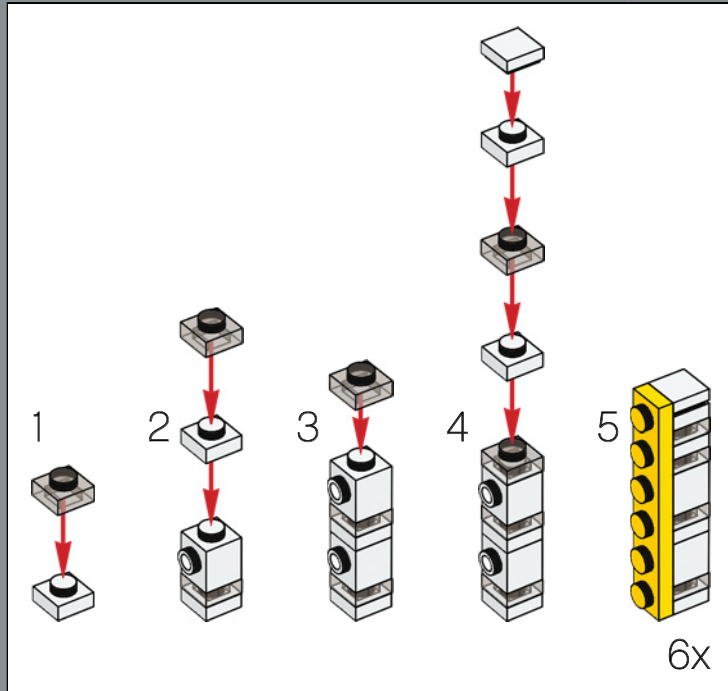

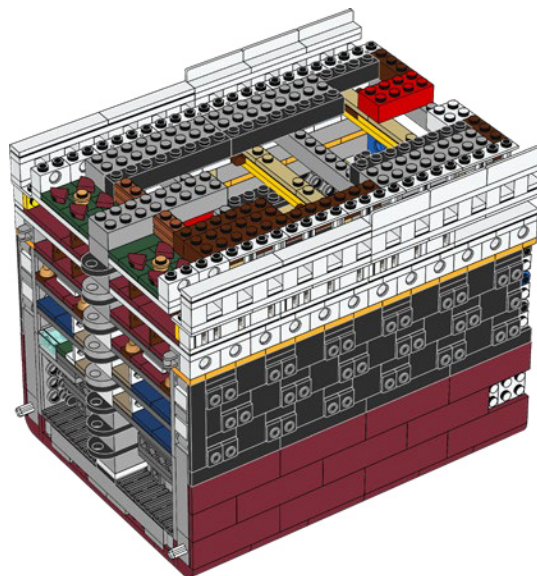
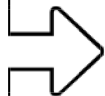

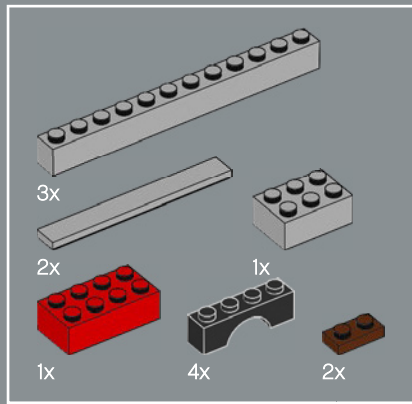

98

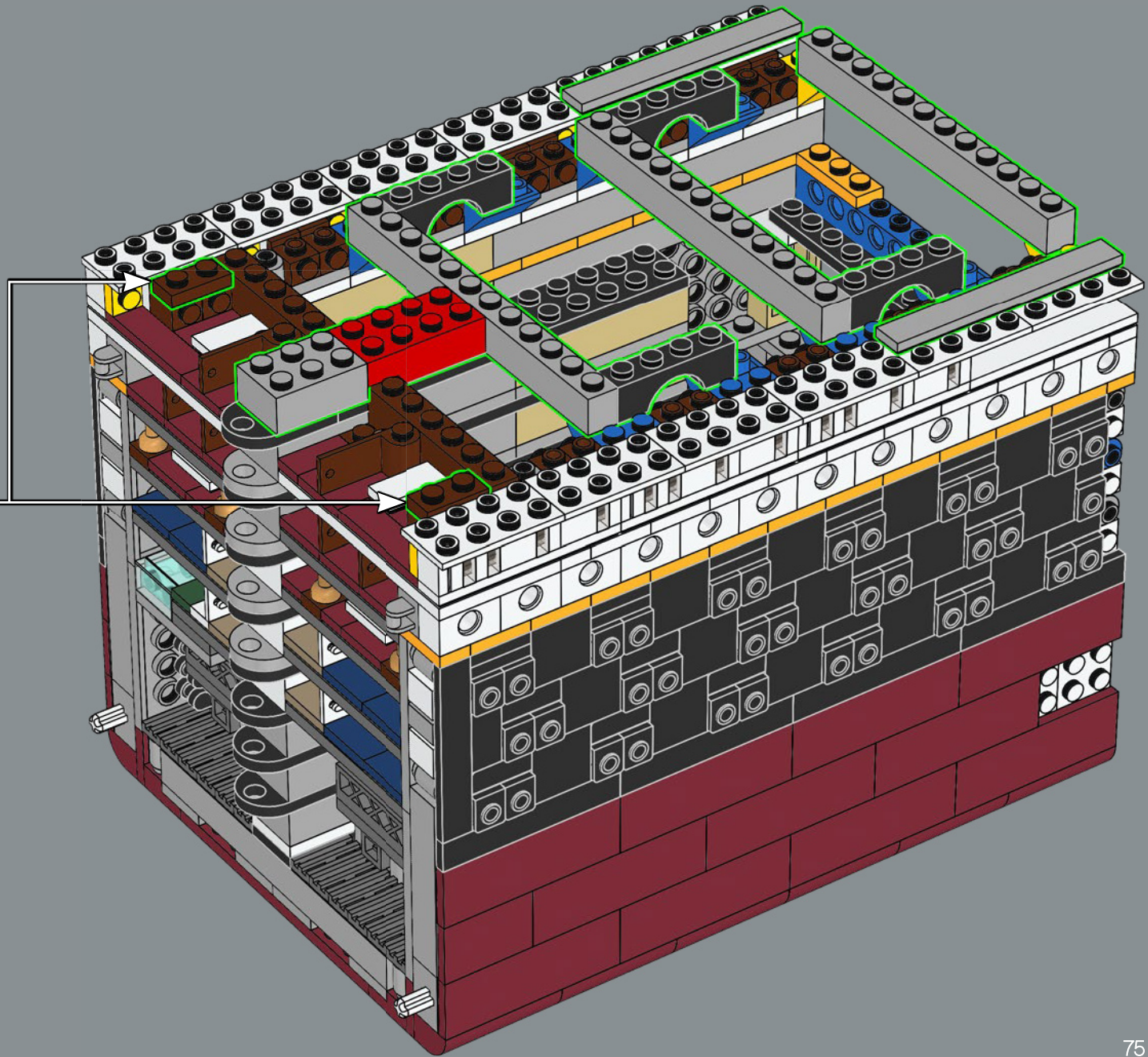
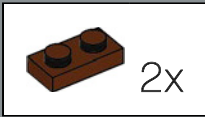

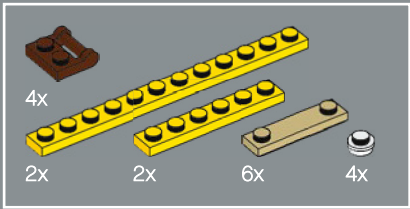

99

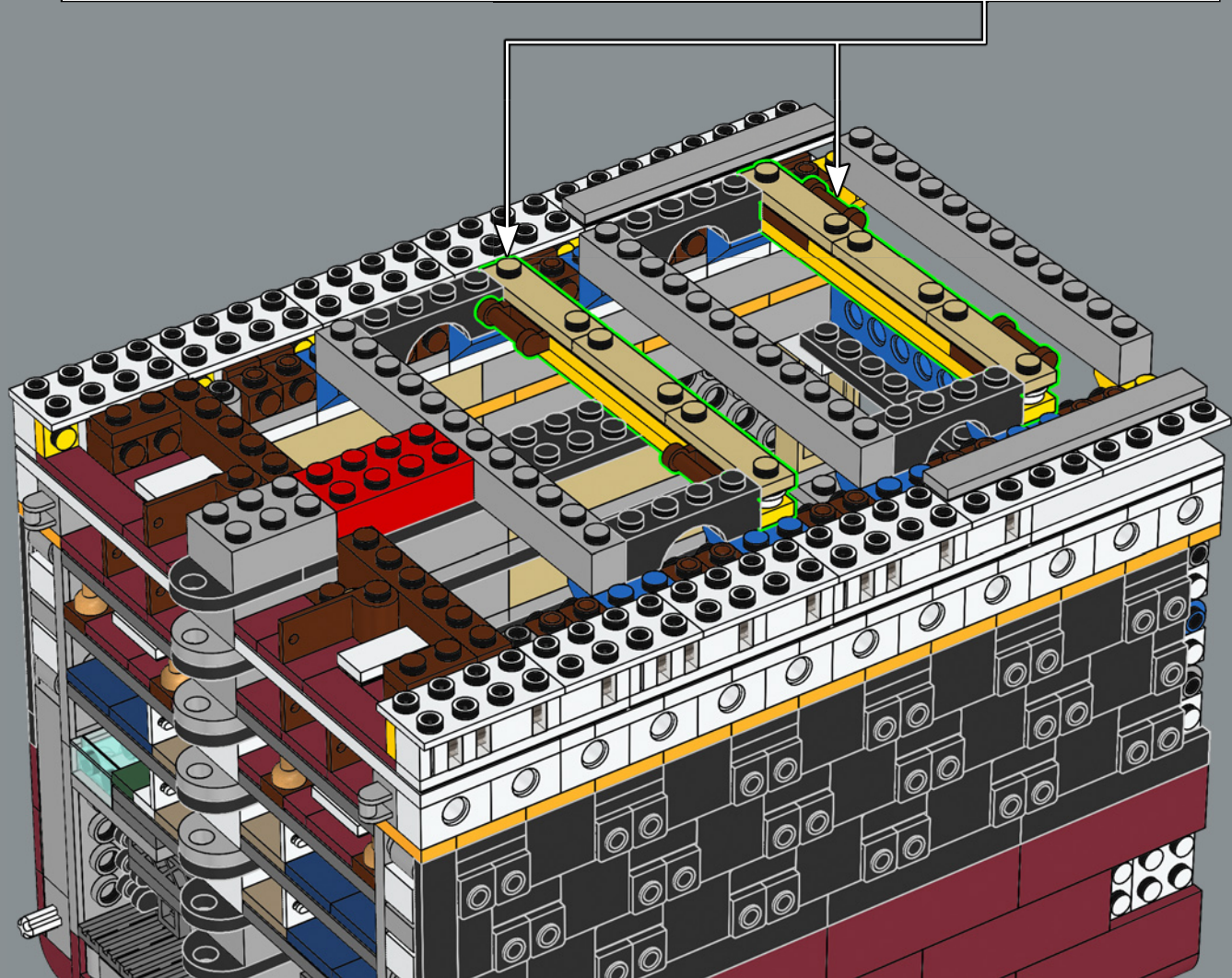
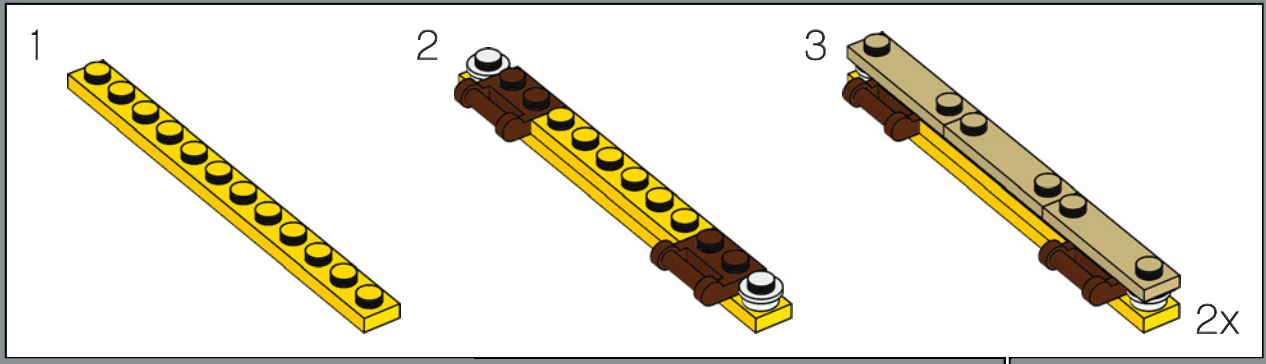

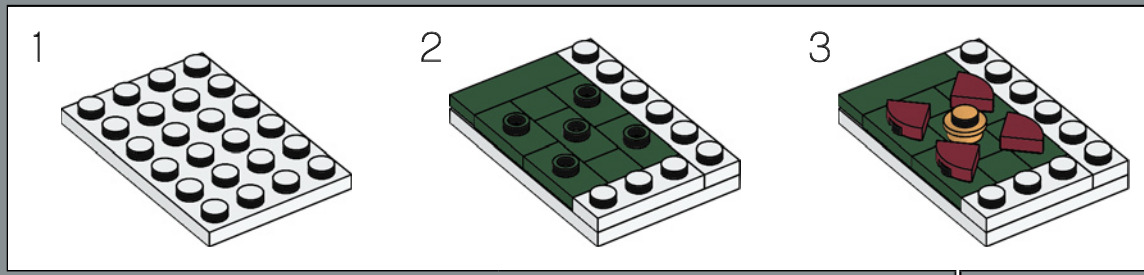
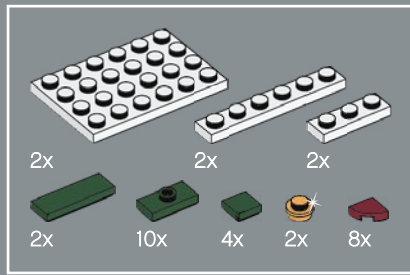

100

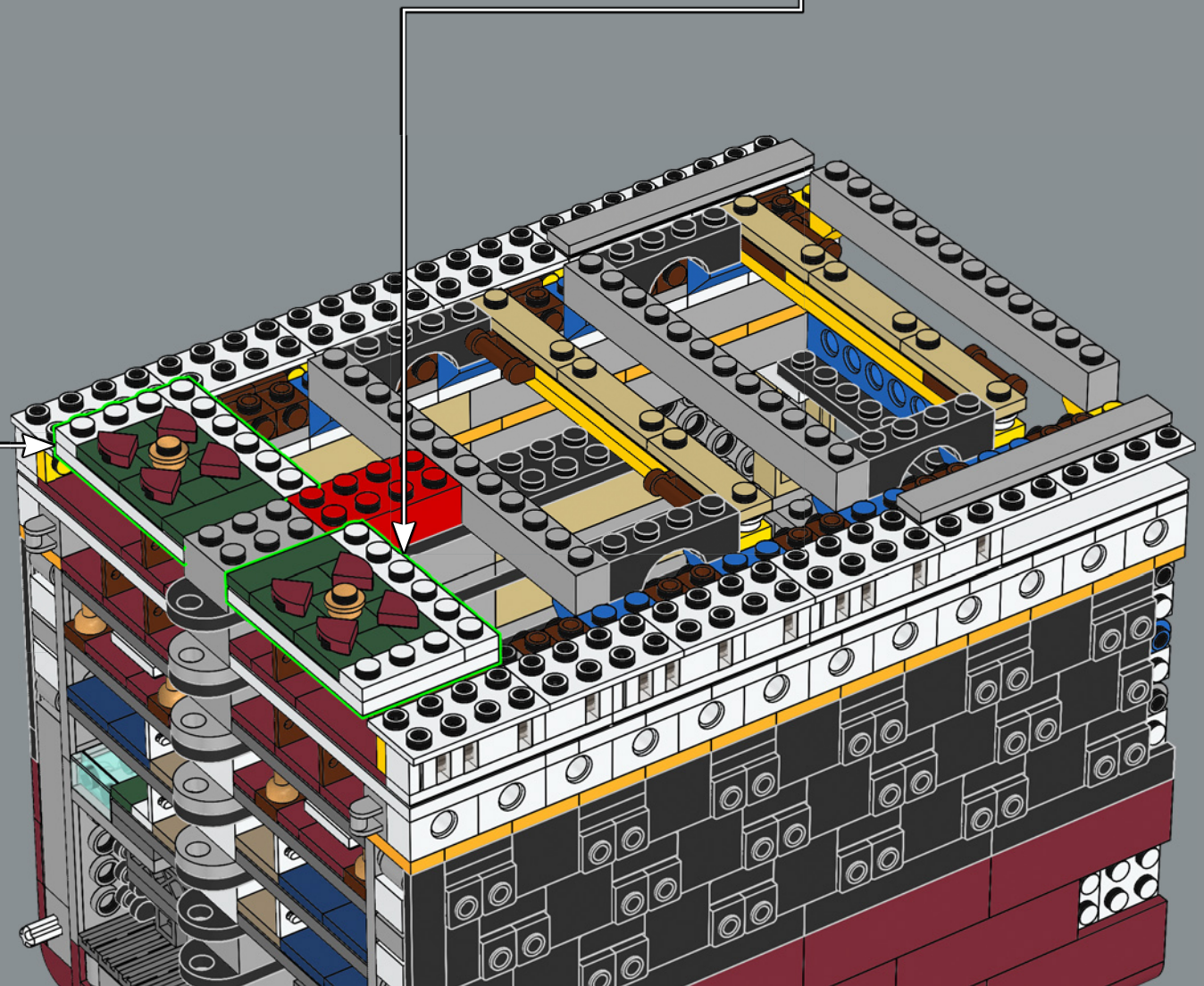
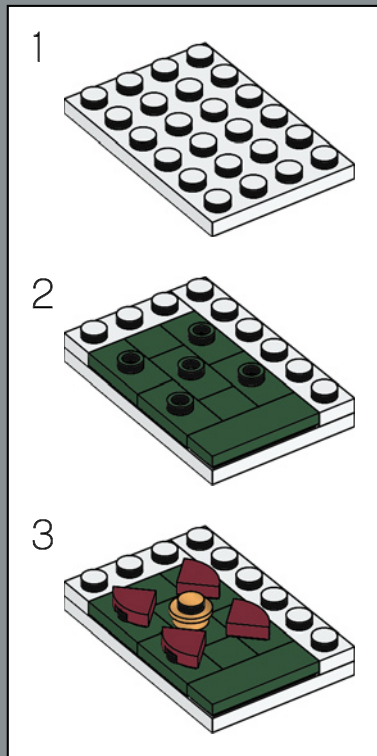

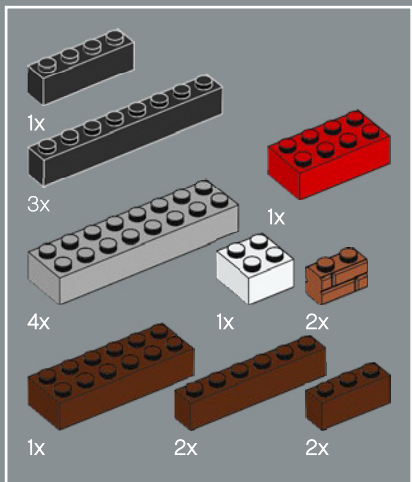

101

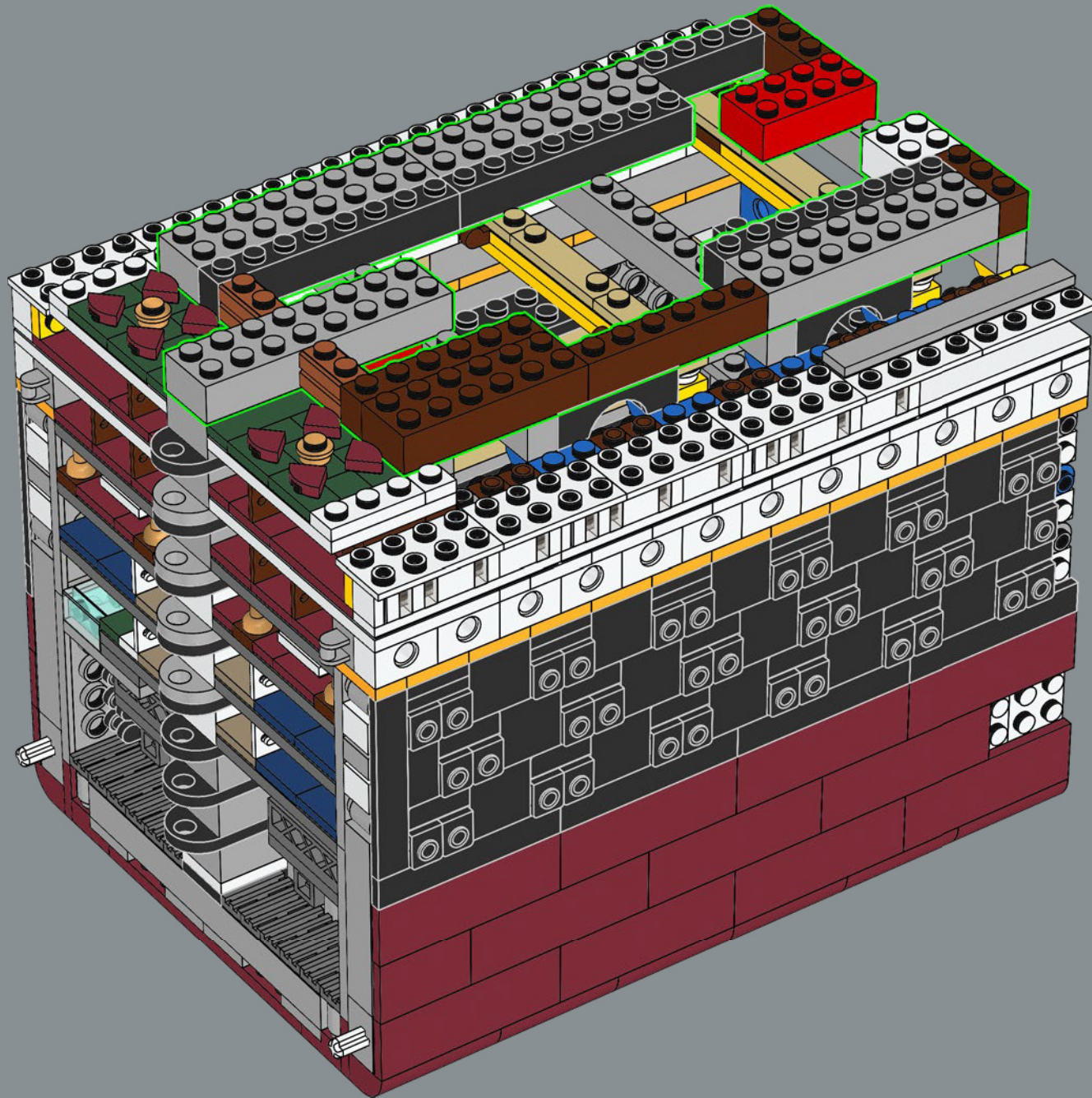

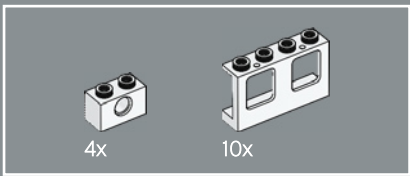

102

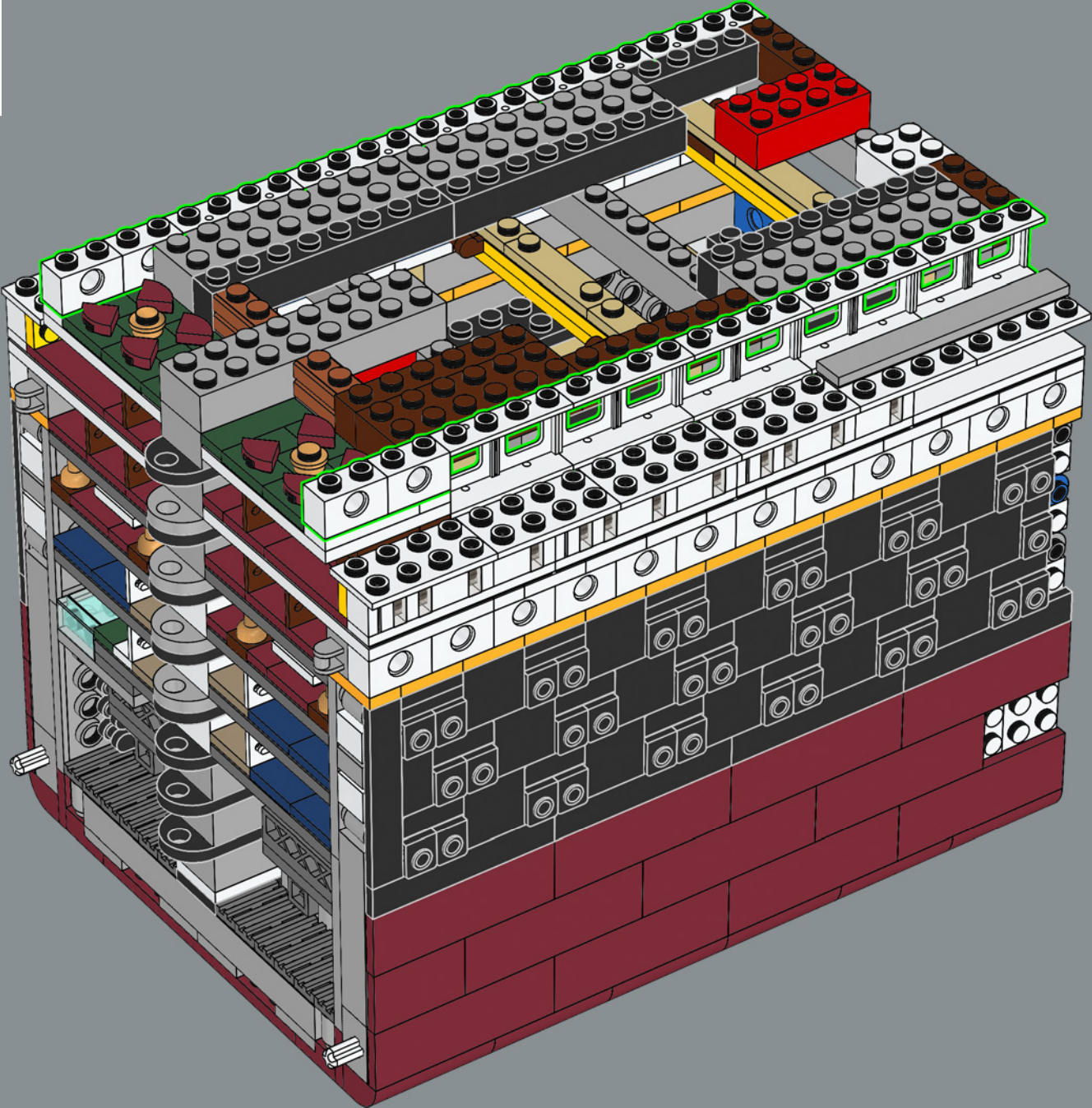

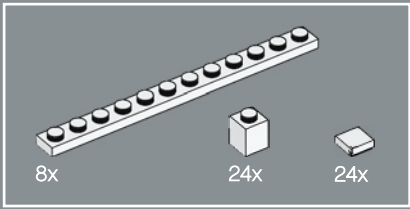

103

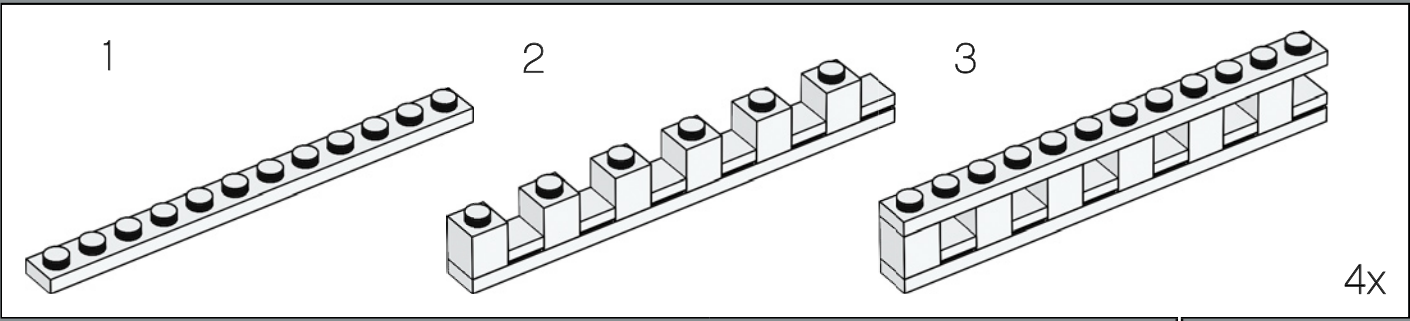

4x

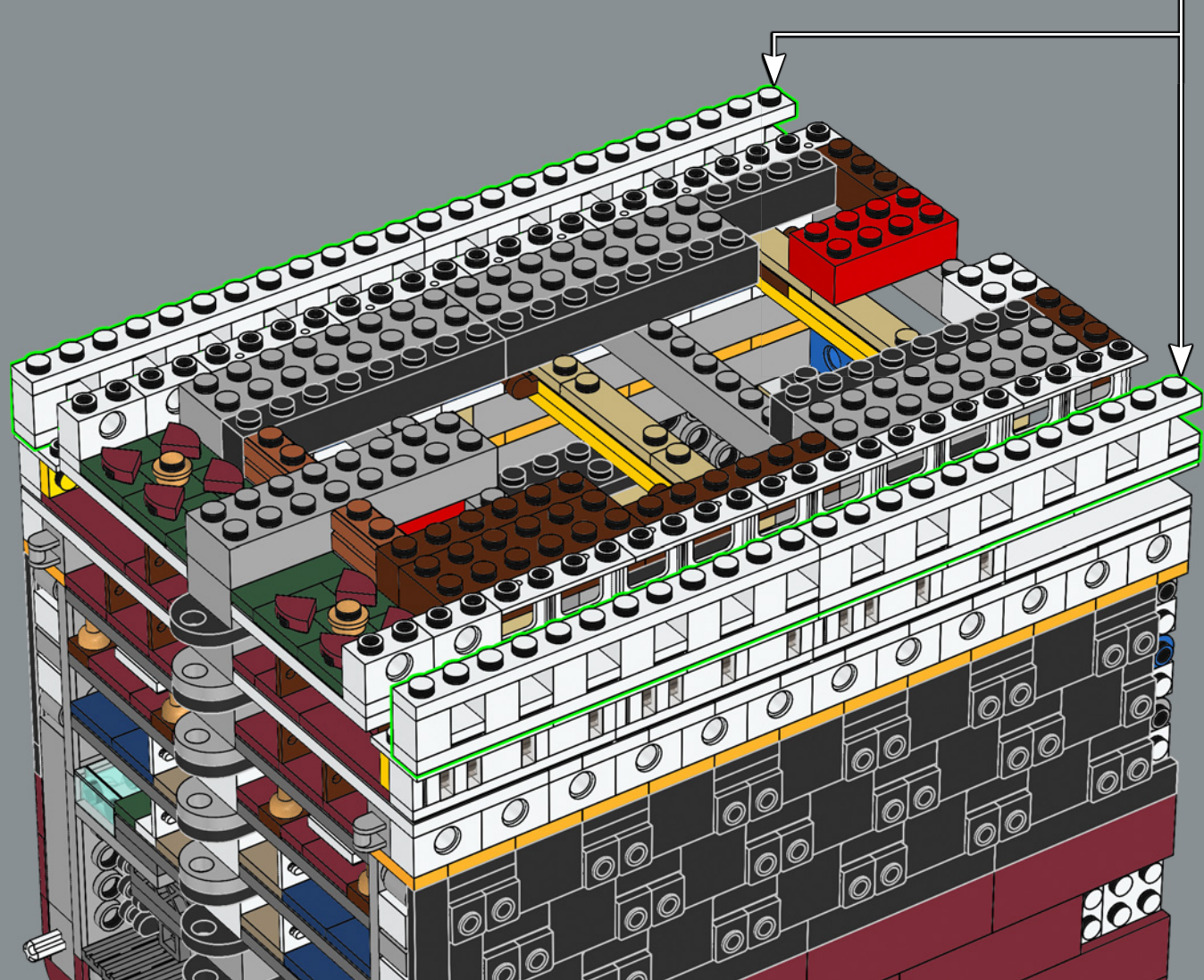



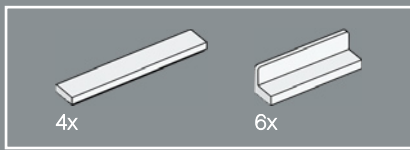

104

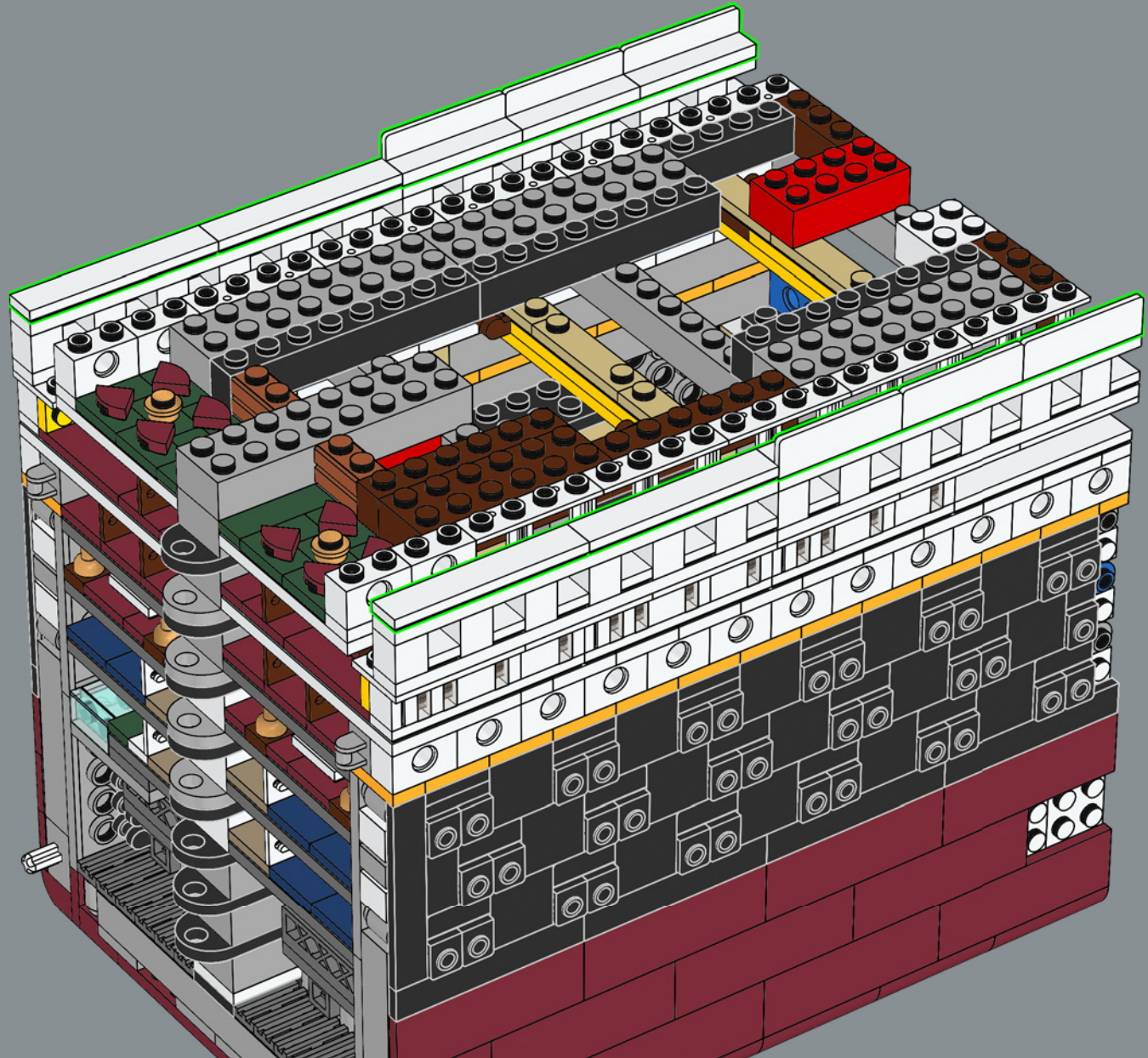

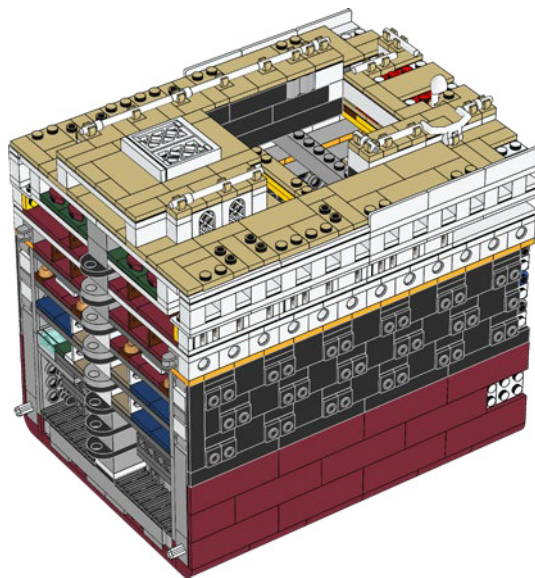
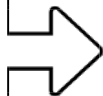

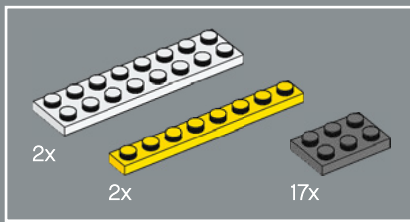

105

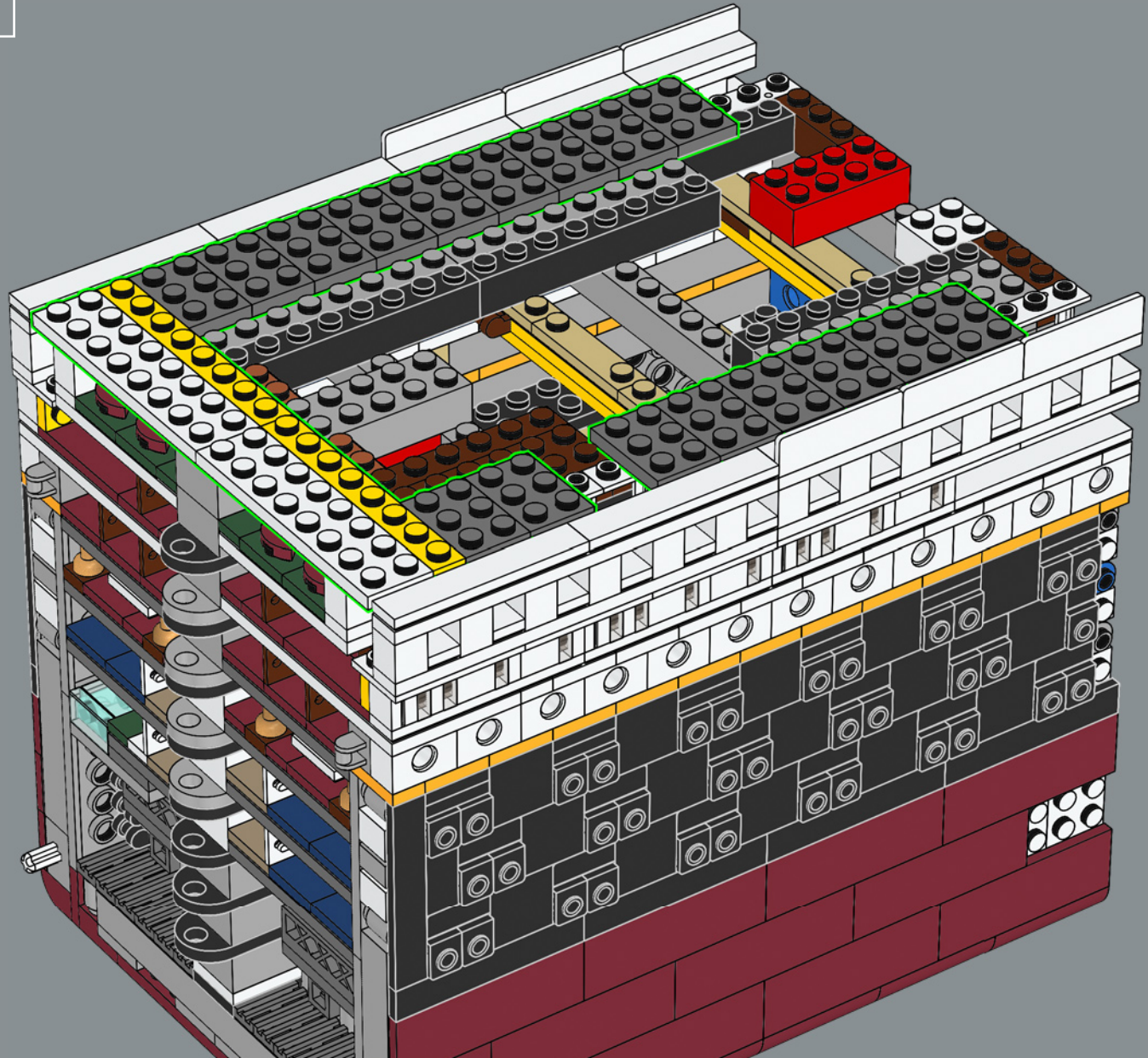

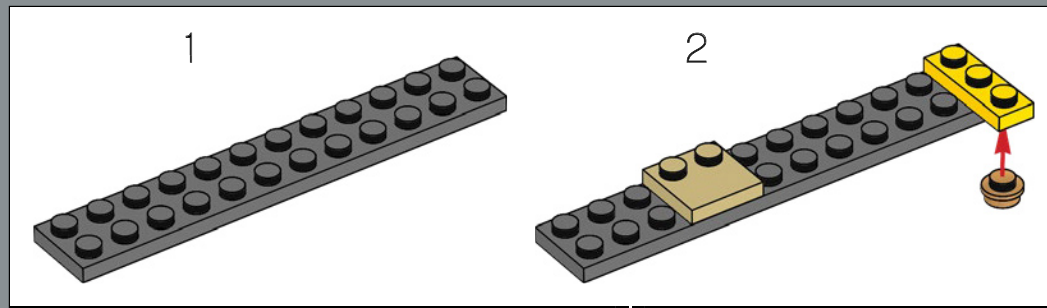
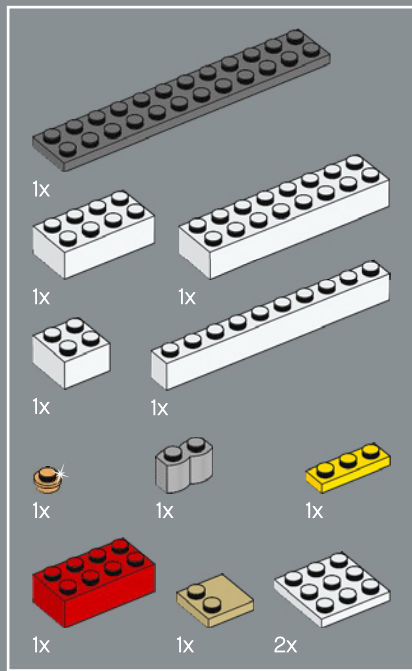

106

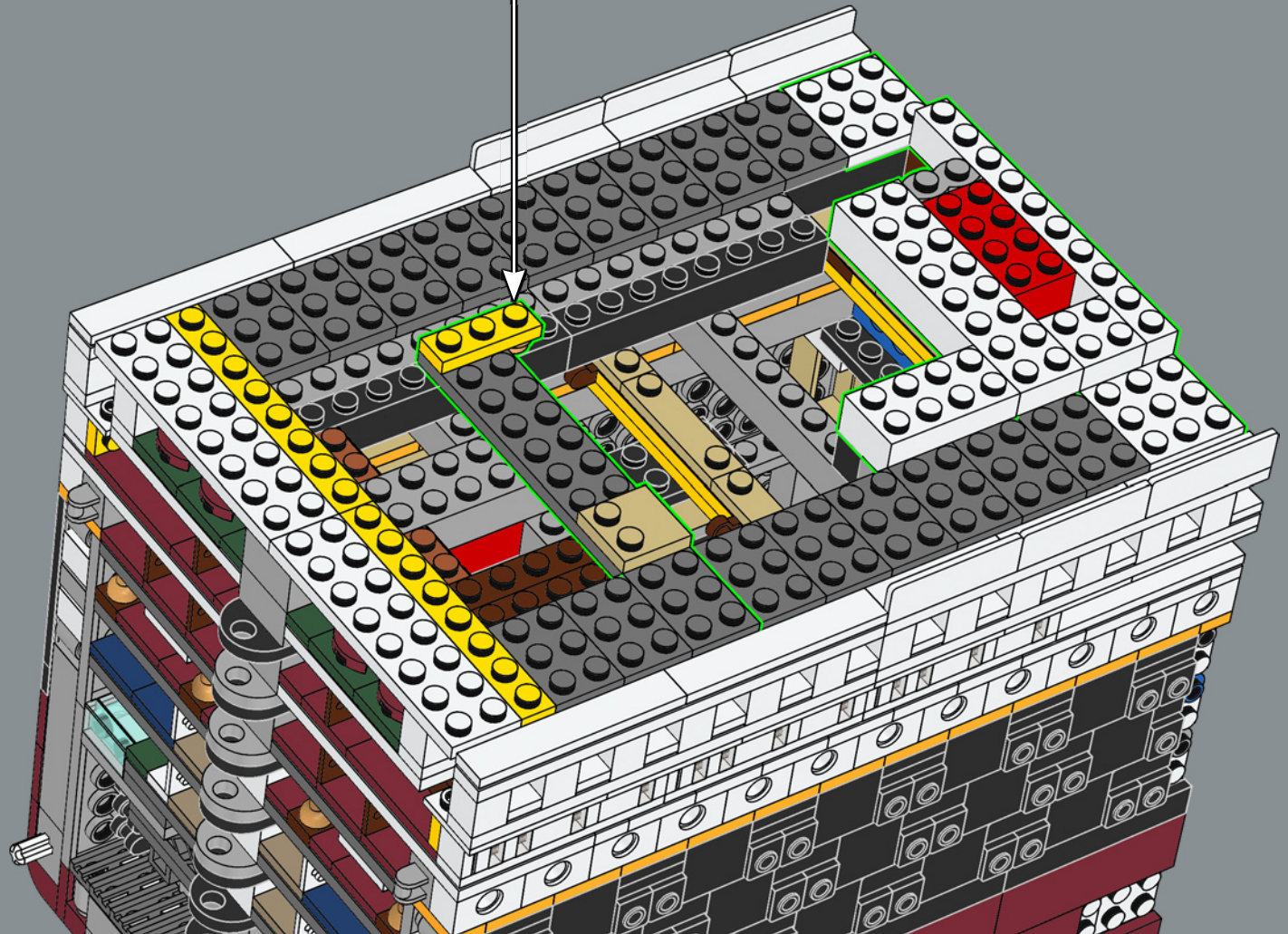

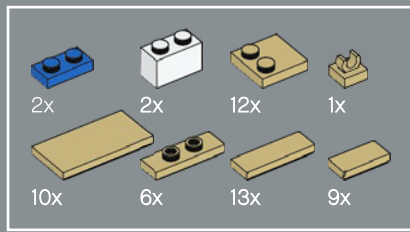

107

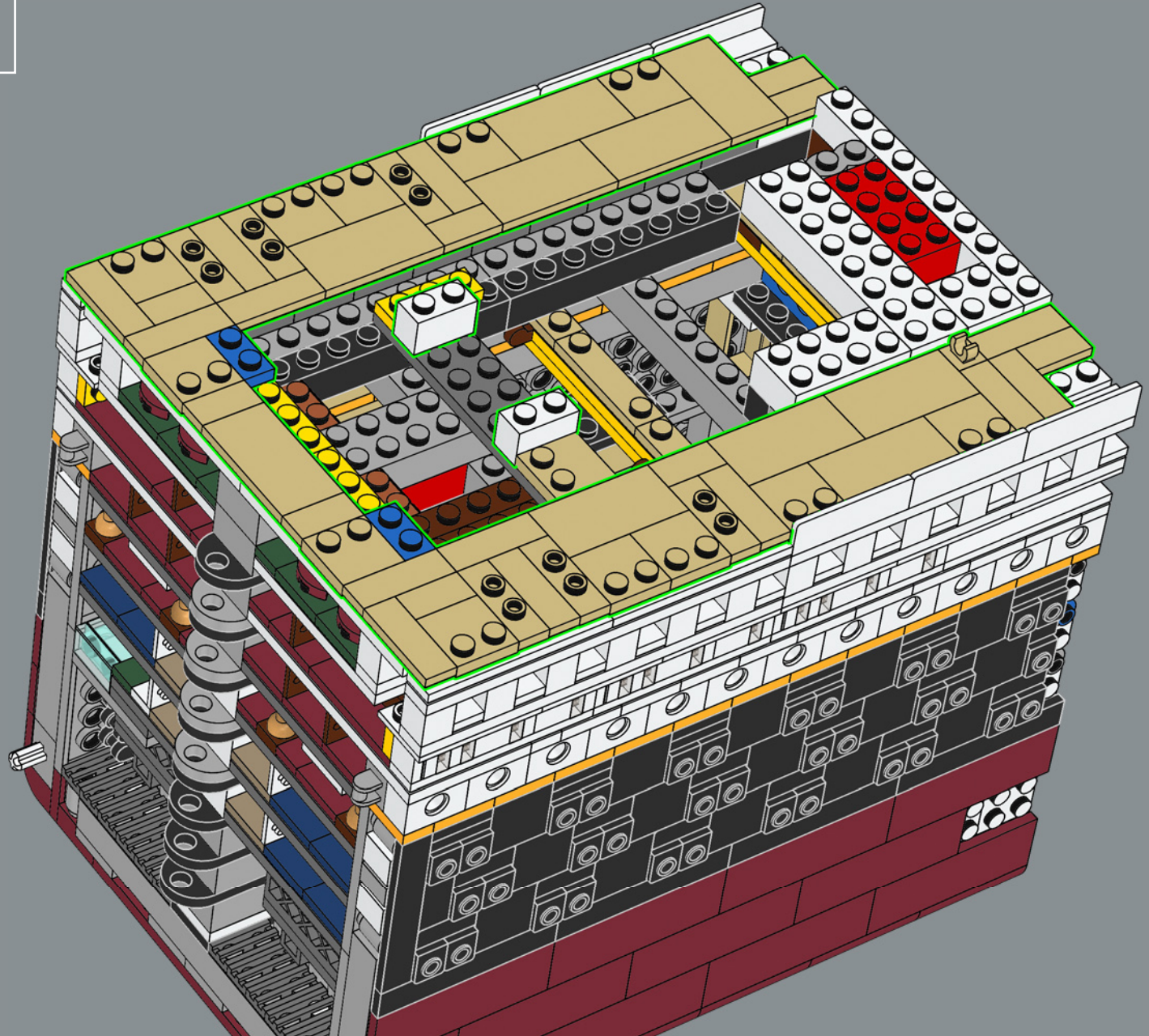

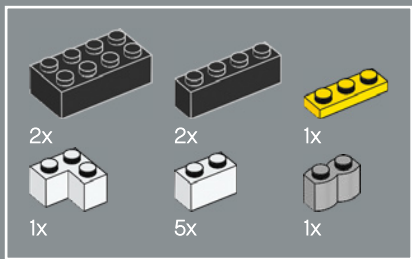

108

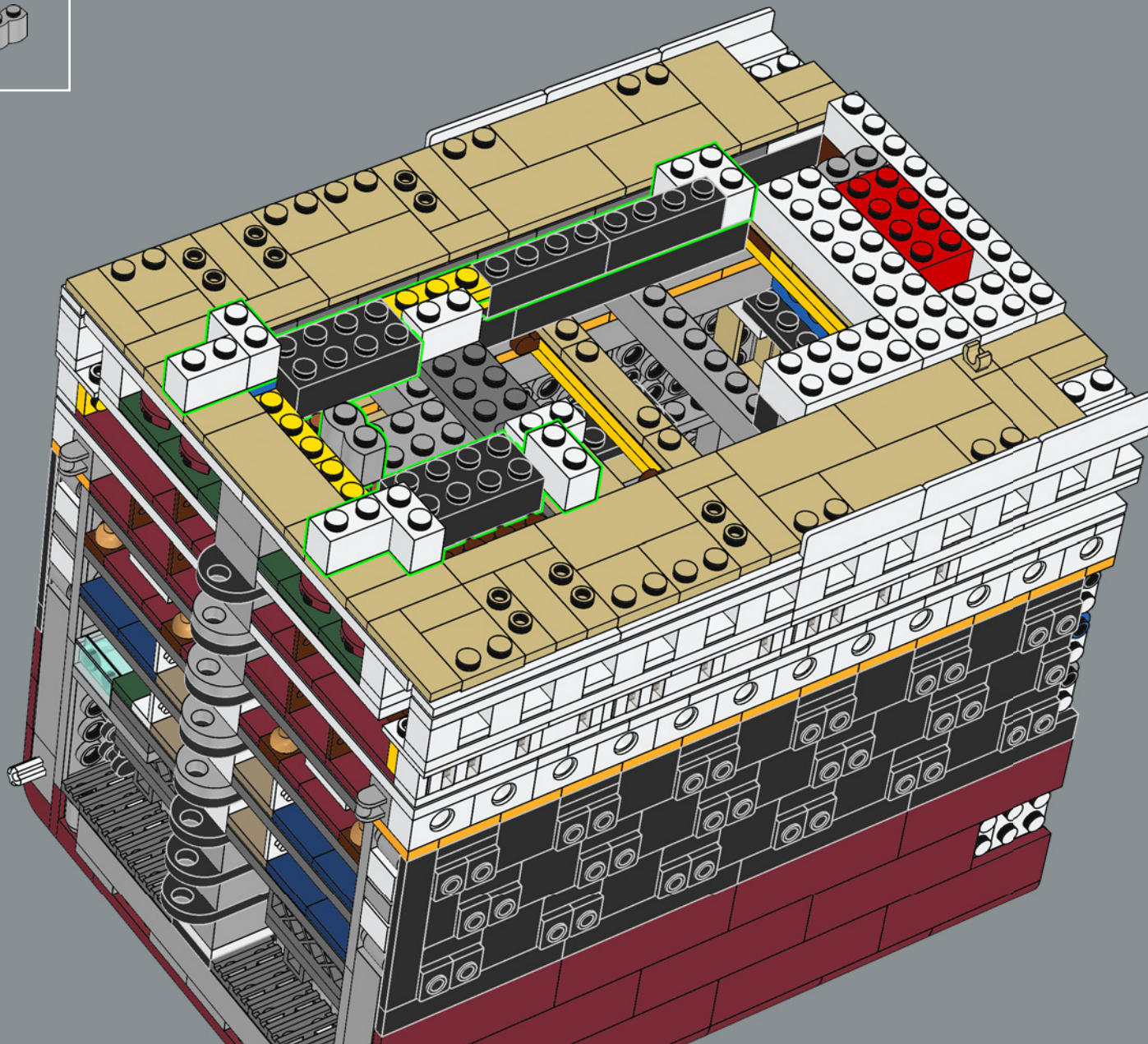

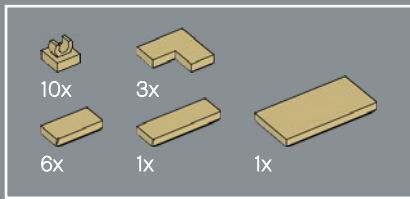

109

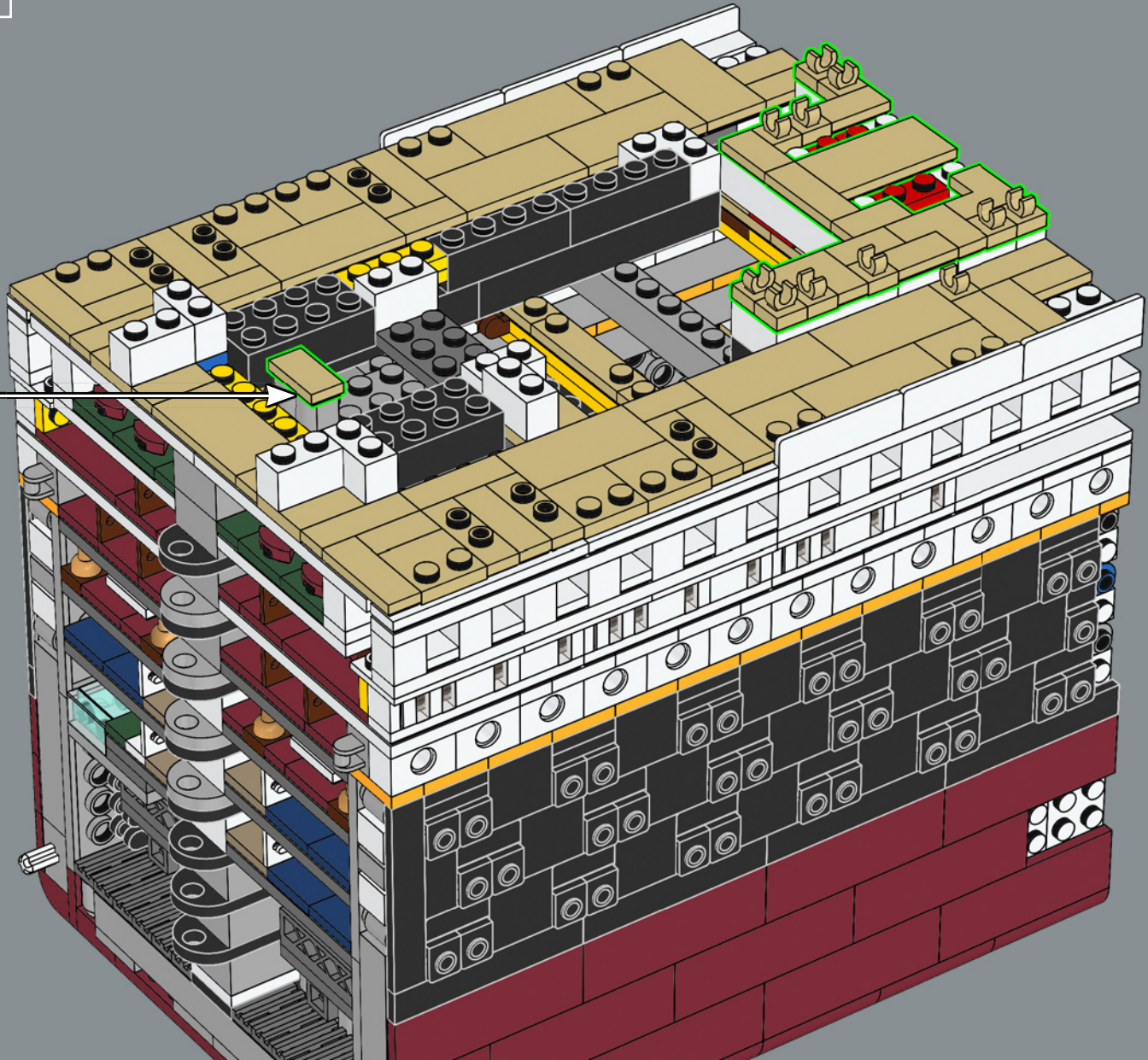

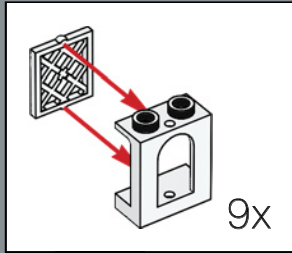
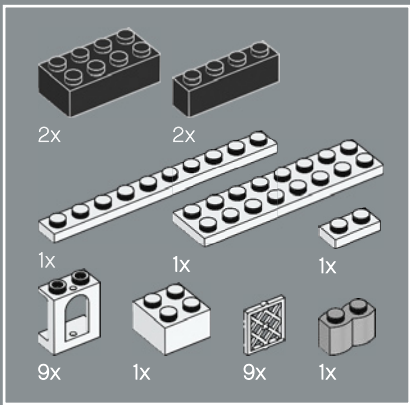

110

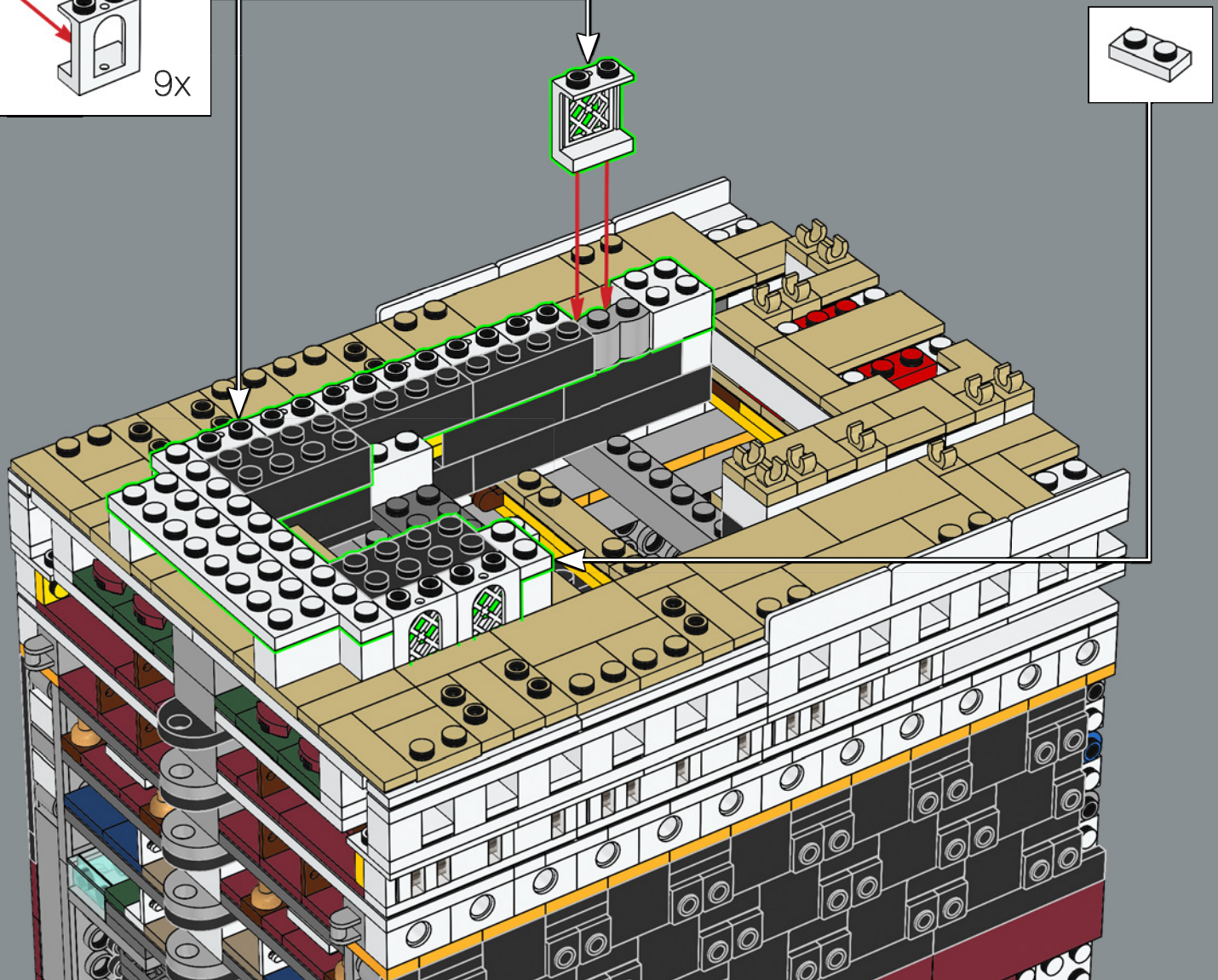



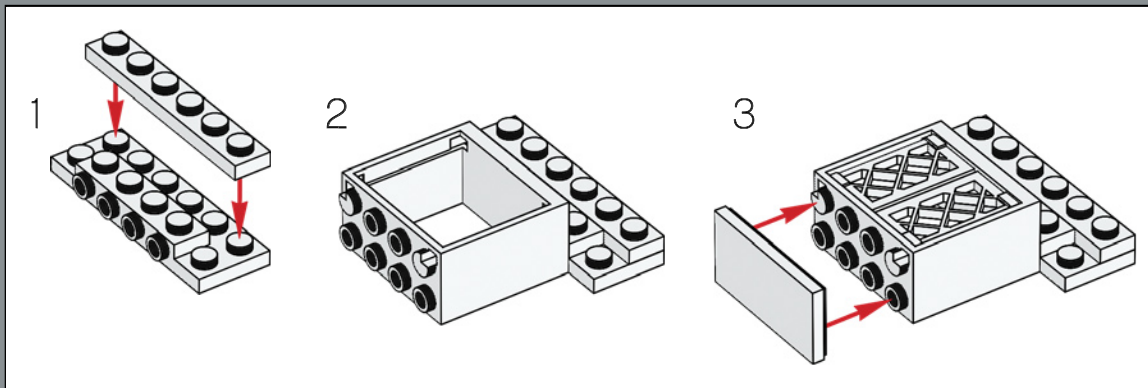
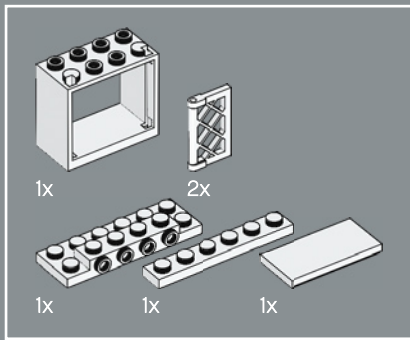

111

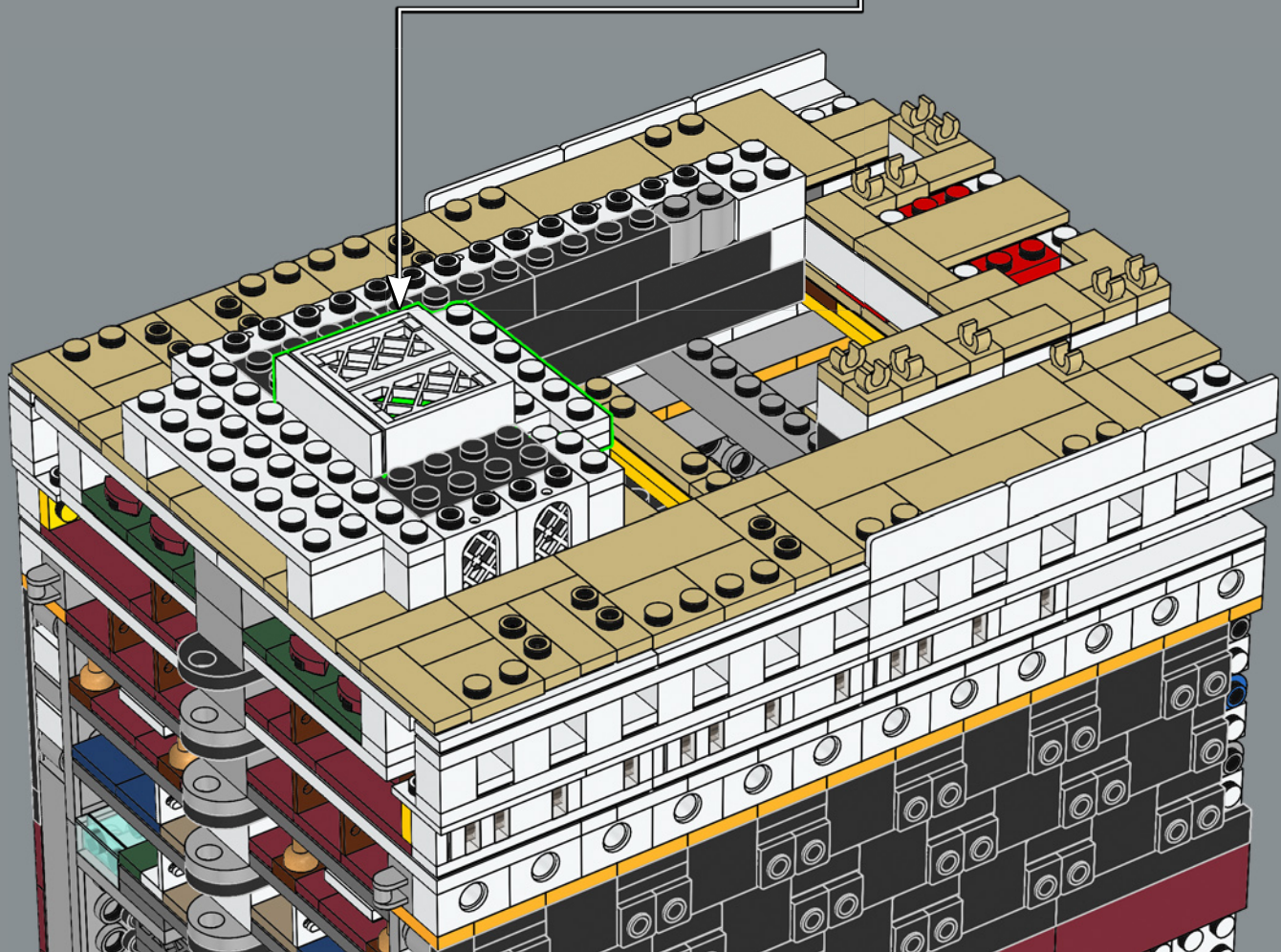

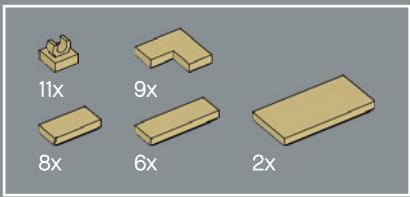

112

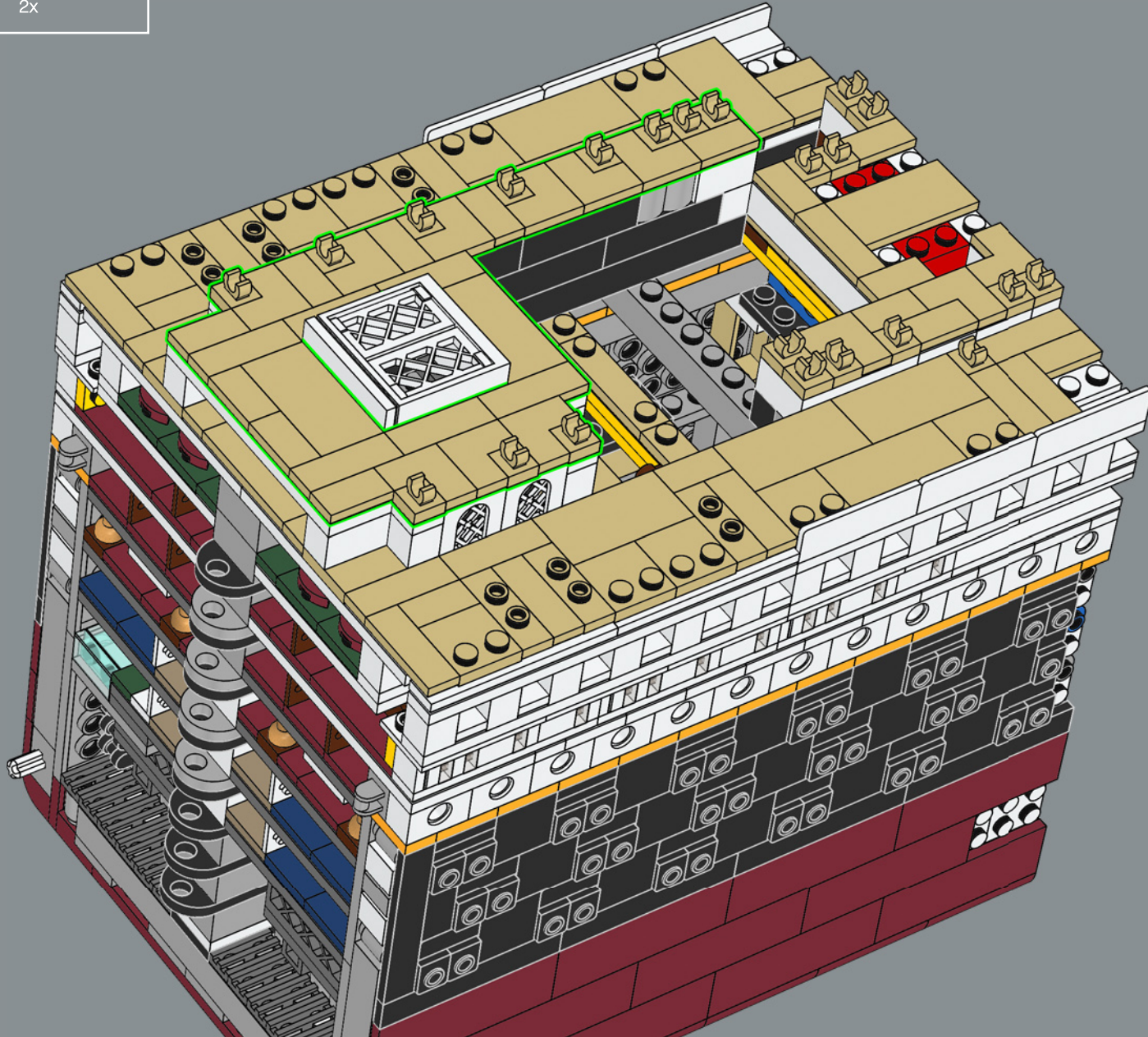

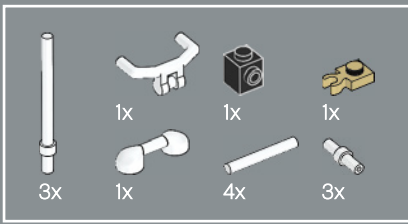

113

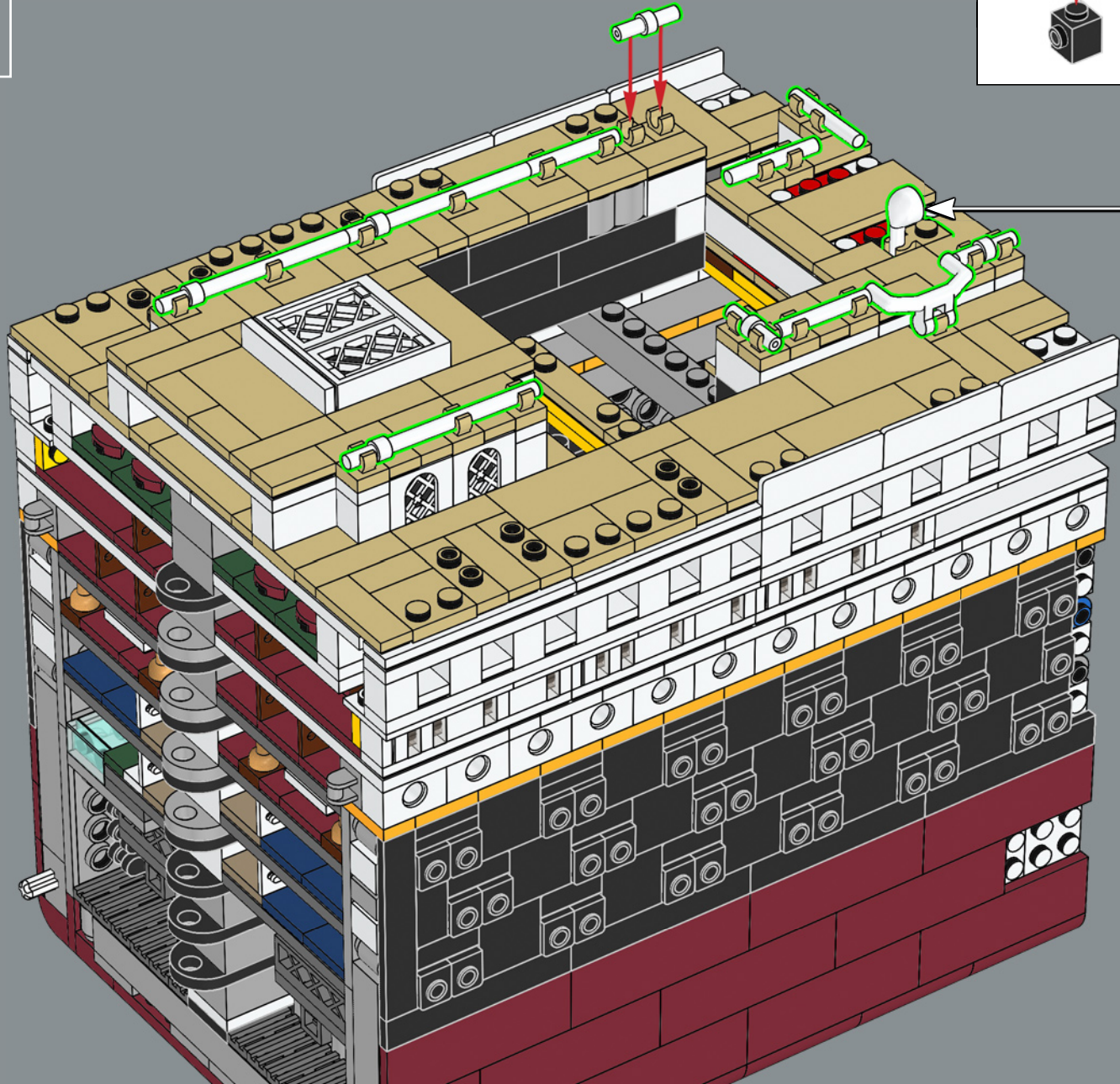
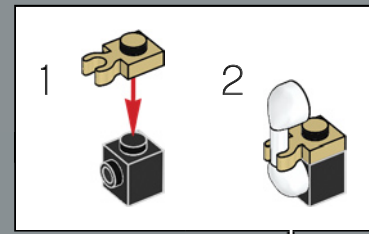

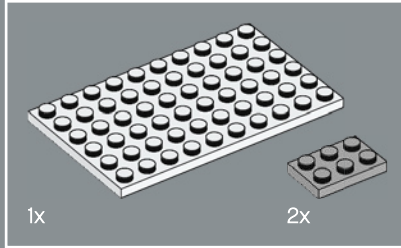
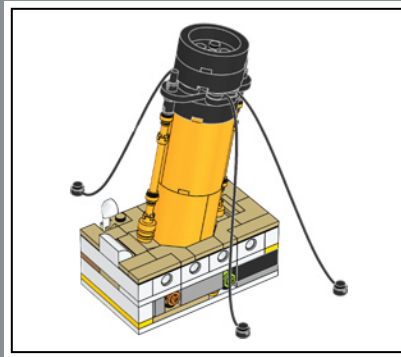
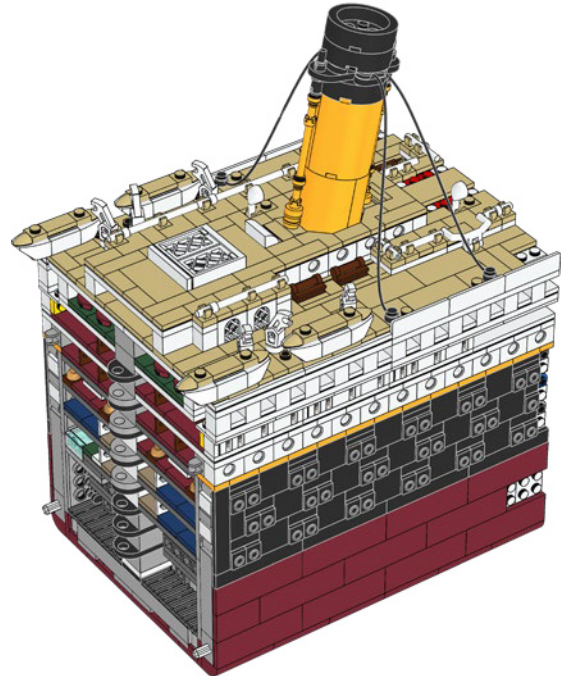
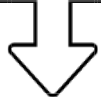

114

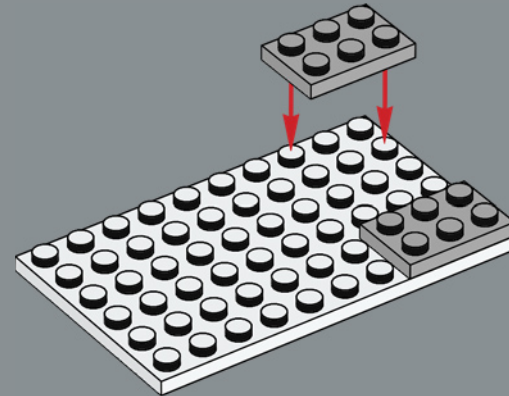

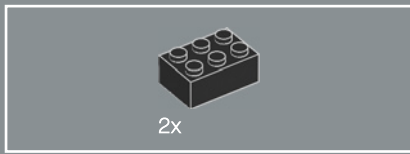

115

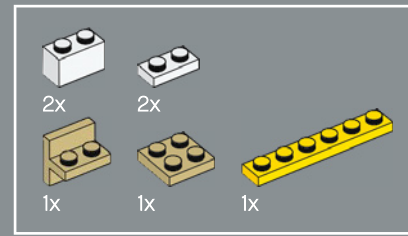
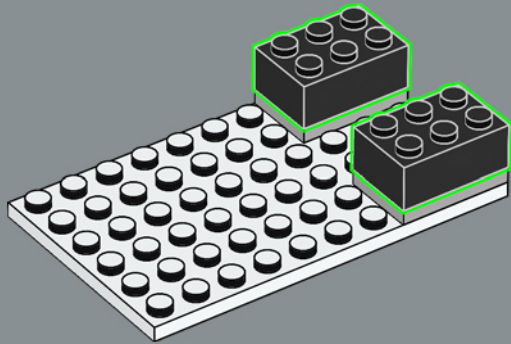

116

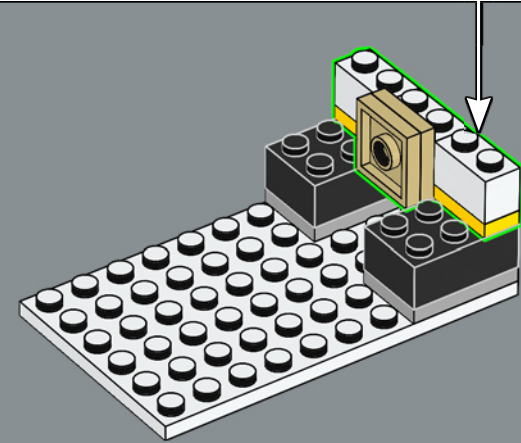
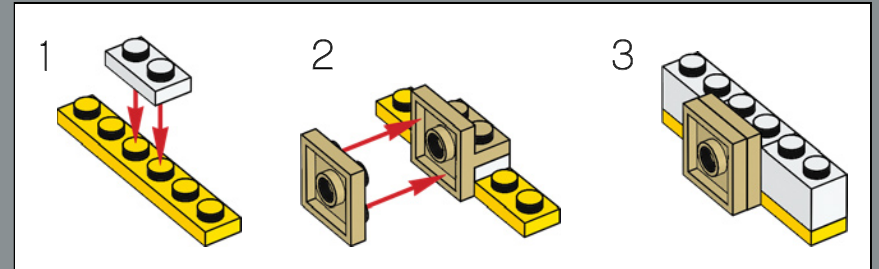

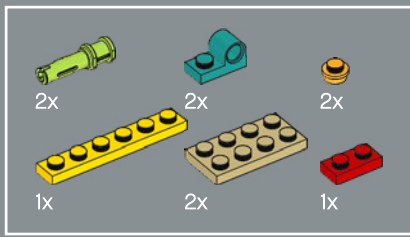

117

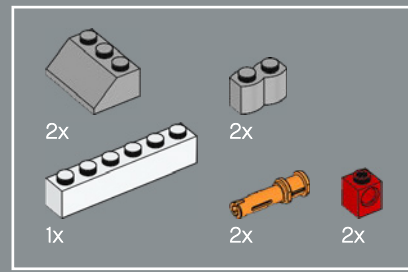
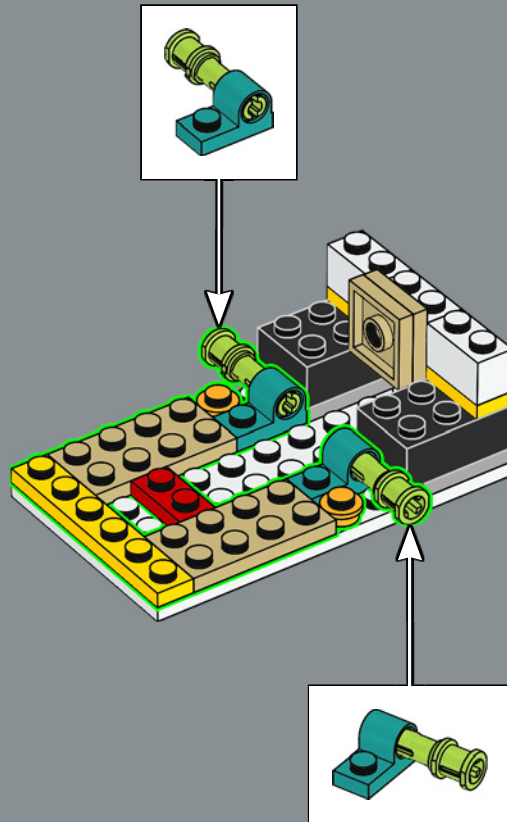

118

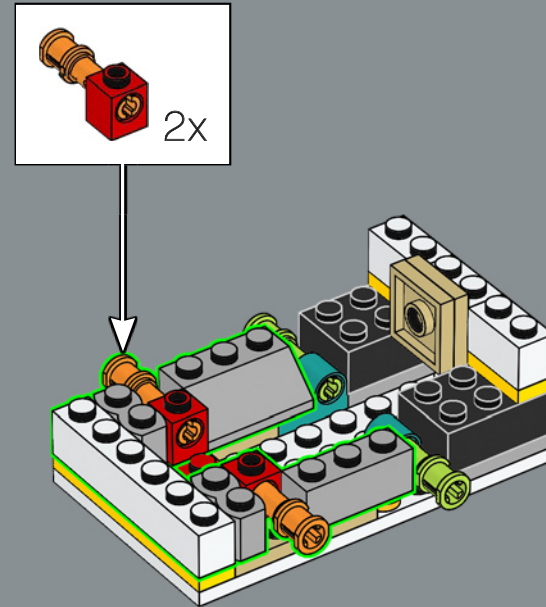

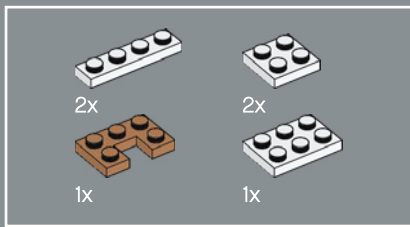

119

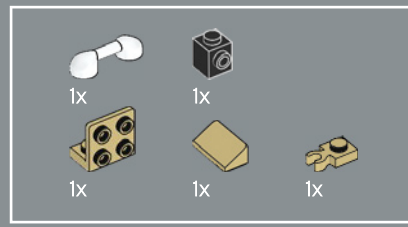
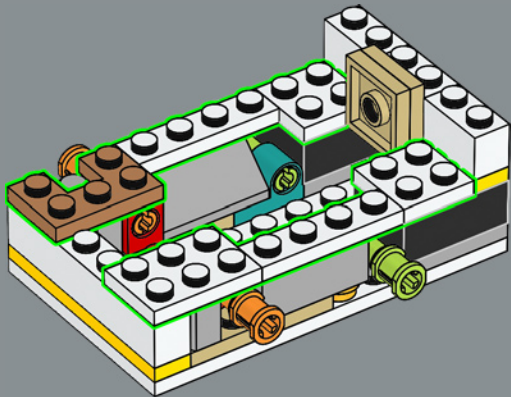

120

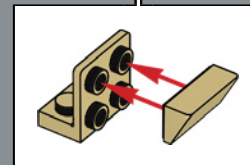
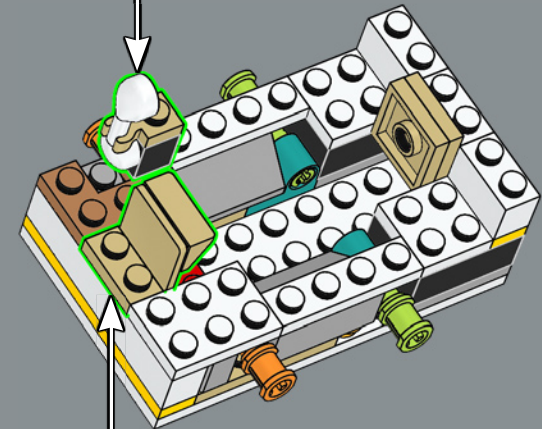
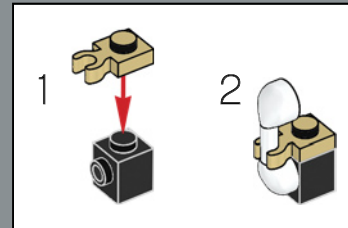

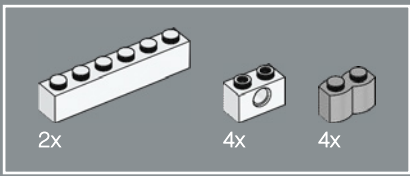

121

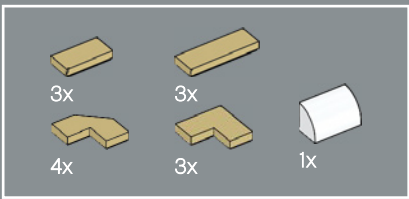
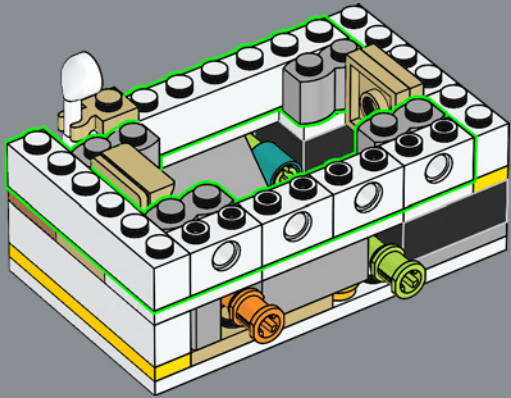

122

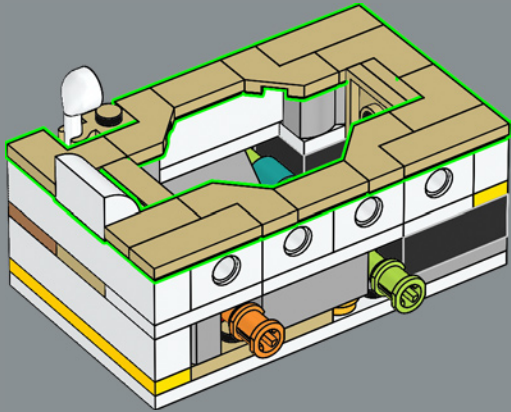



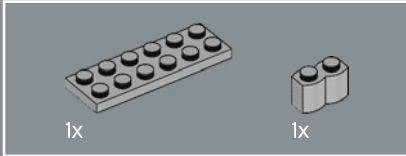
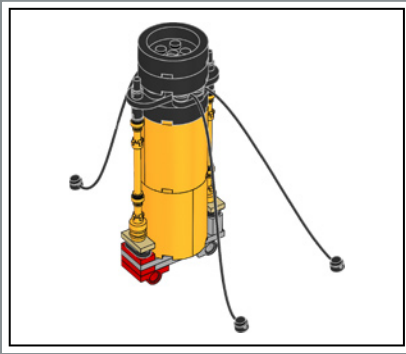

123

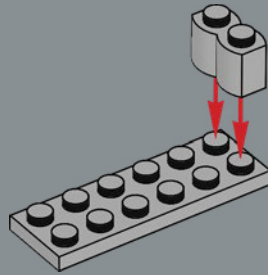

124

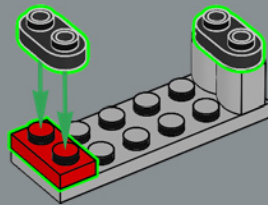

125

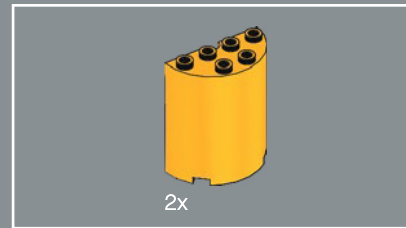
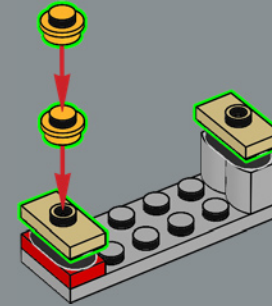

126

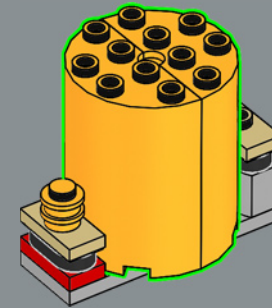

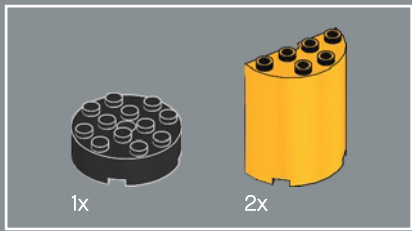

127

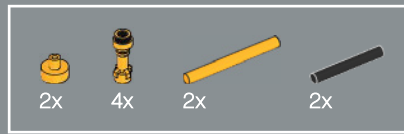
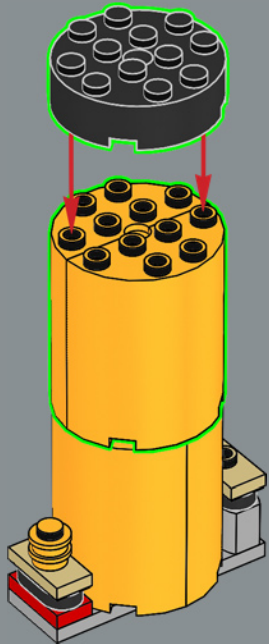

128

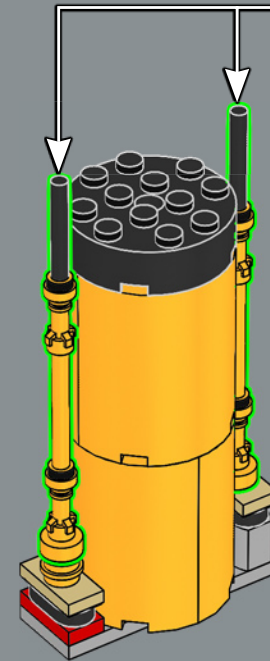
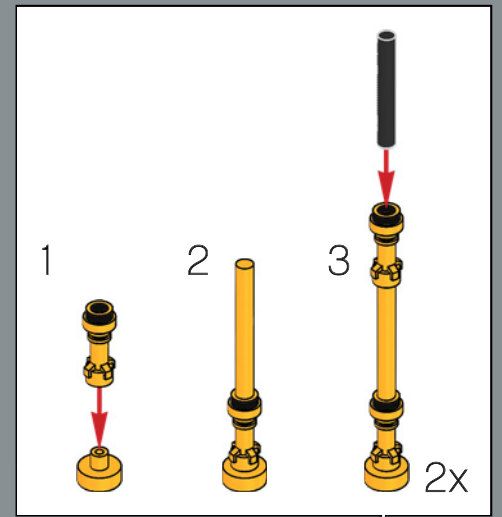

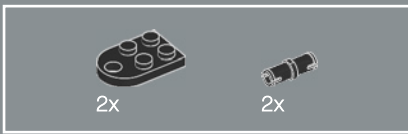

129

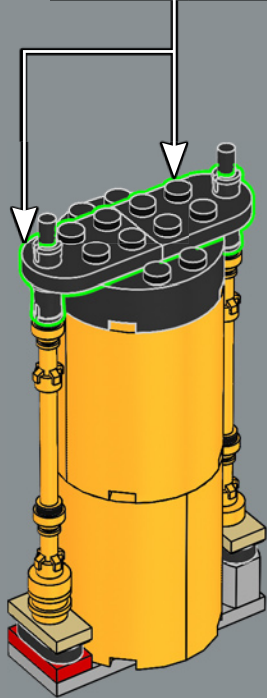
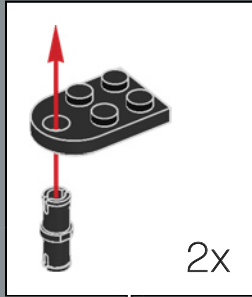

130

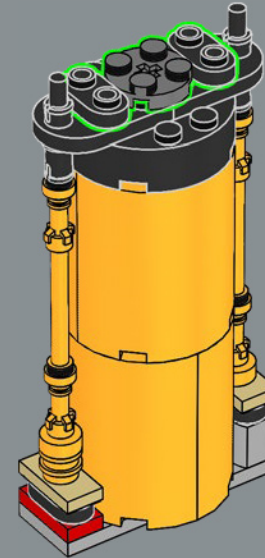



131

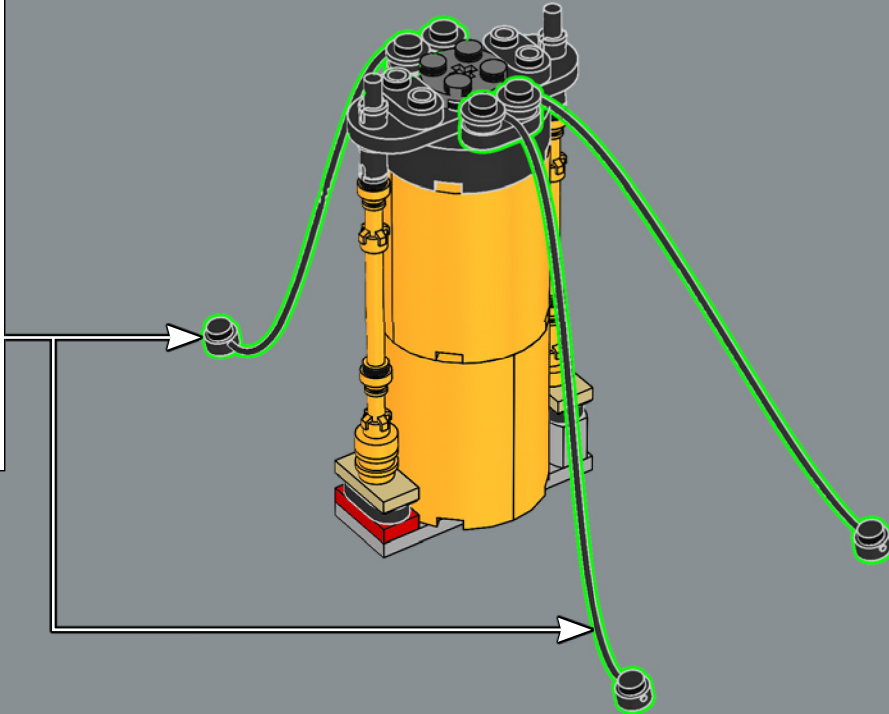
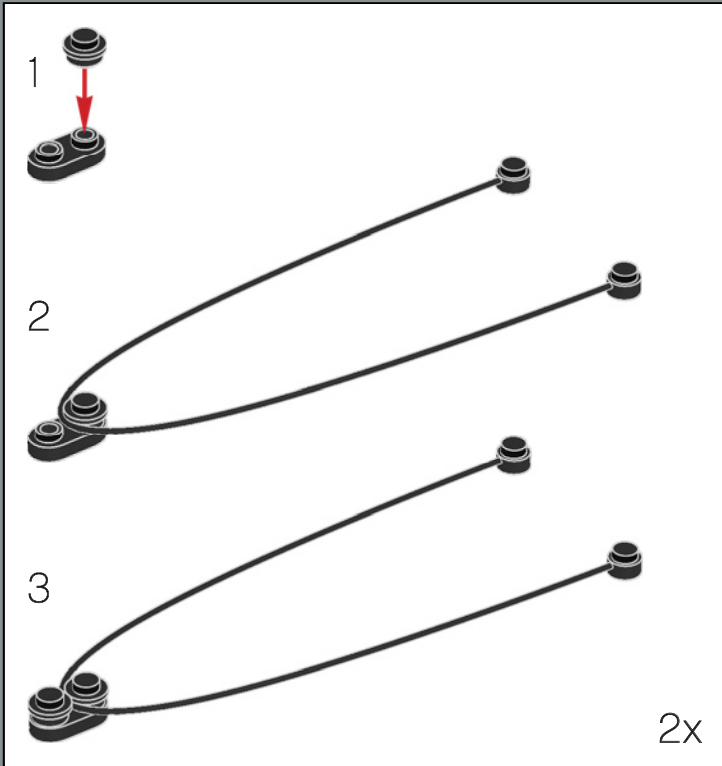

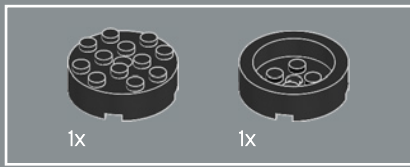

132

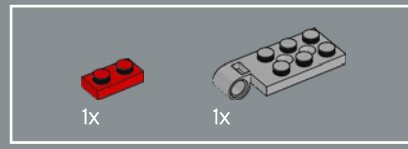
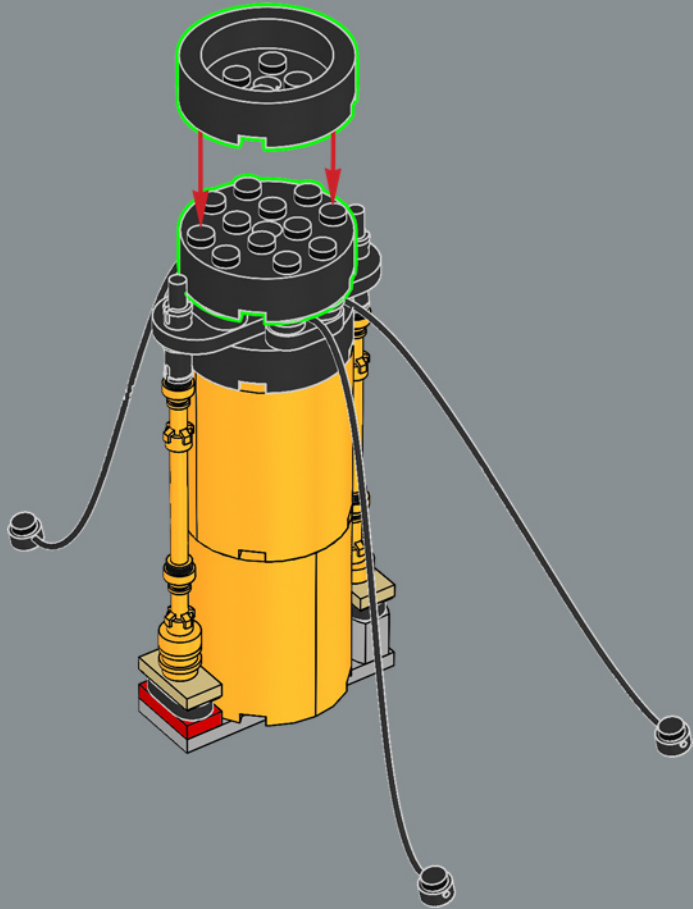

133

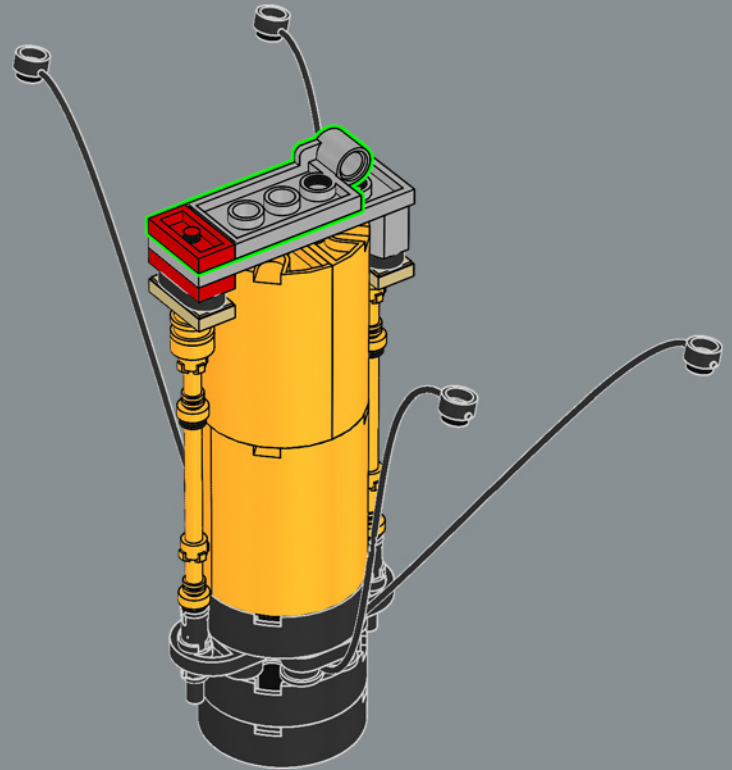

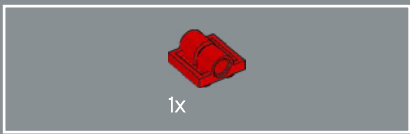

134

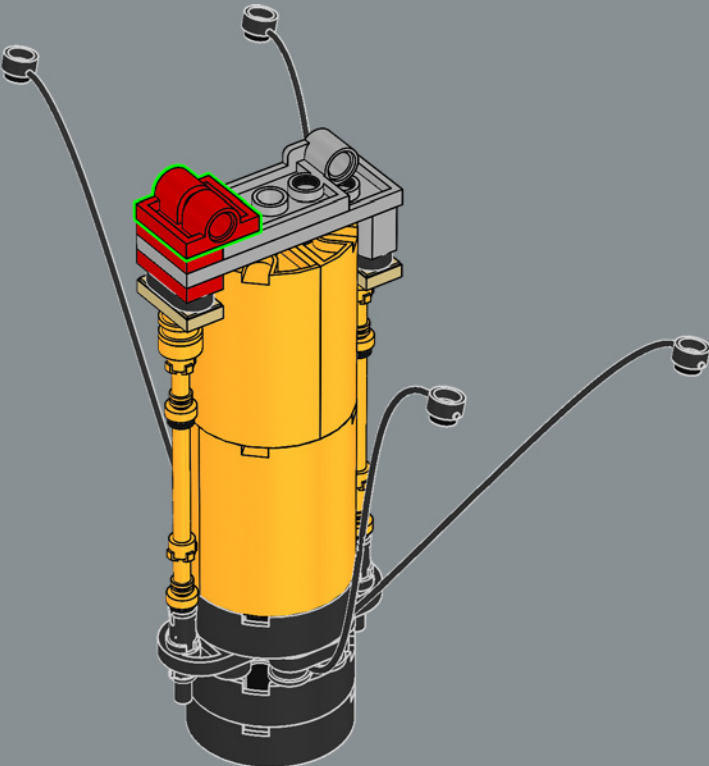

135

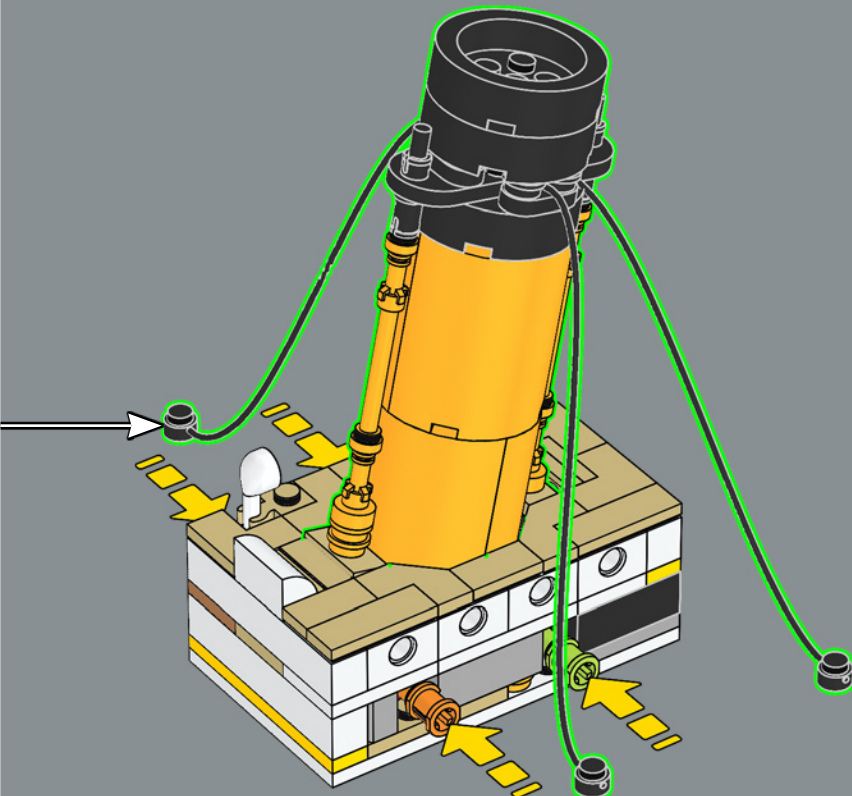

136

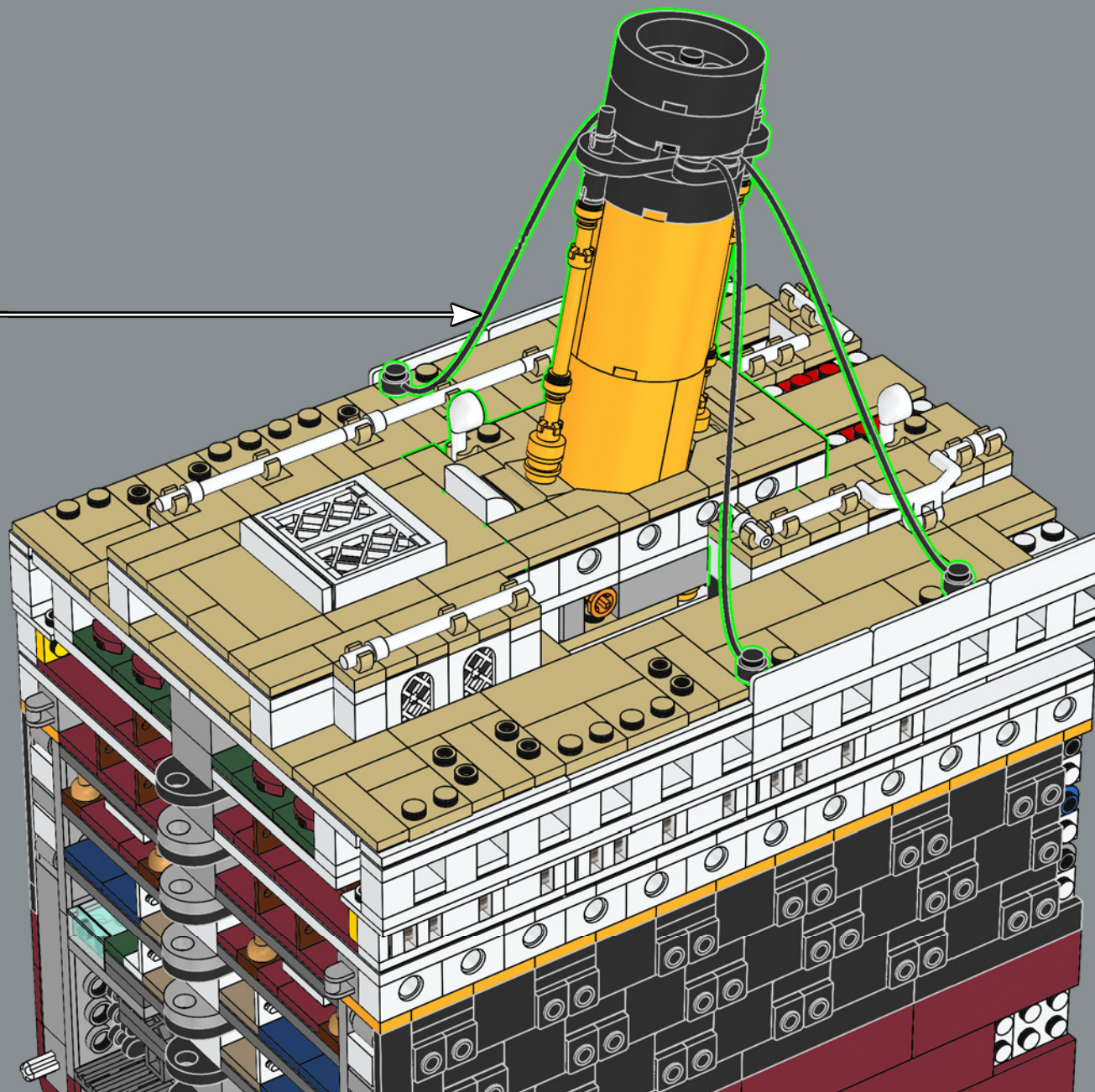

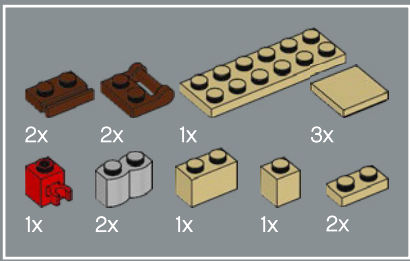

137

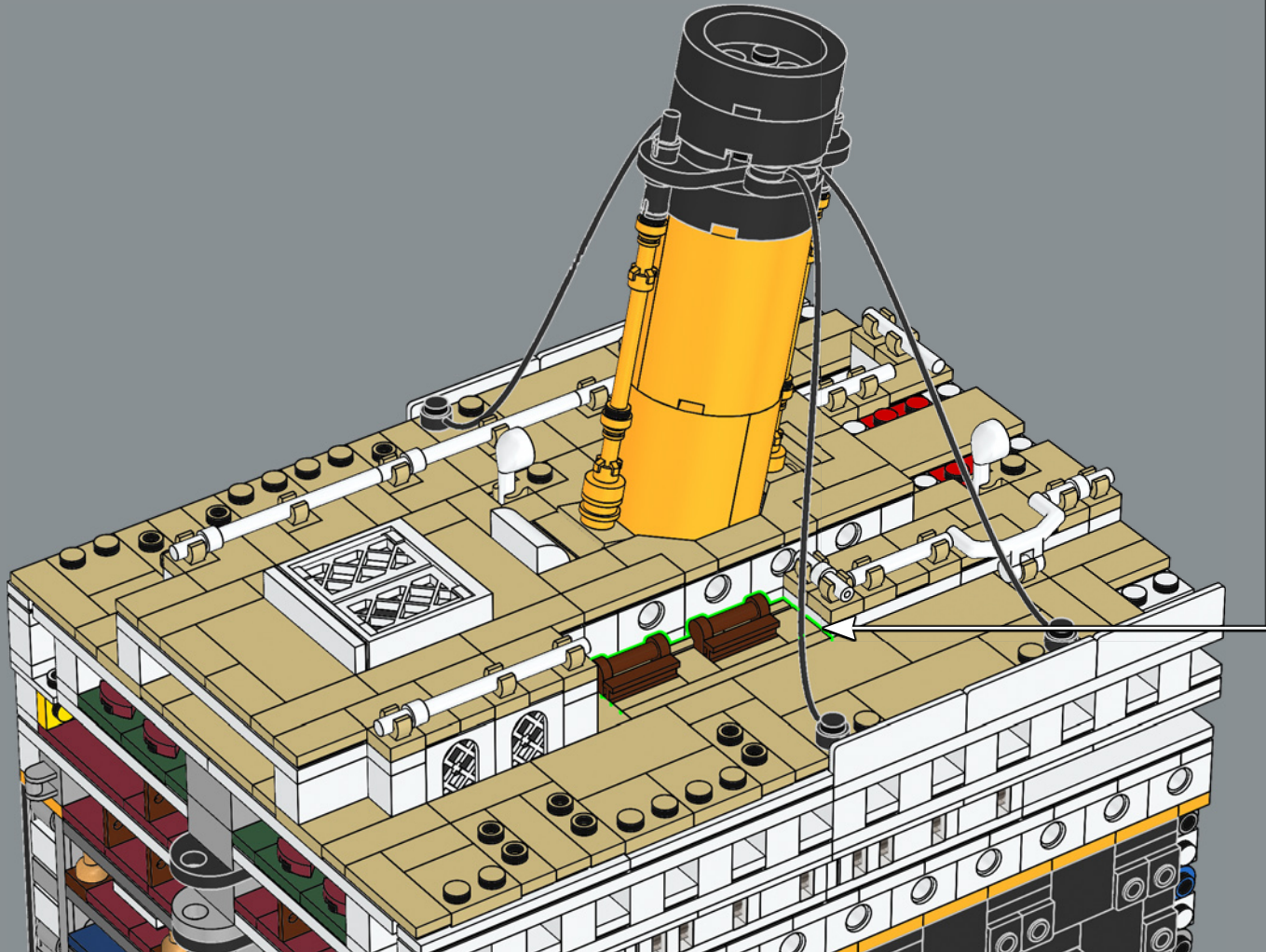
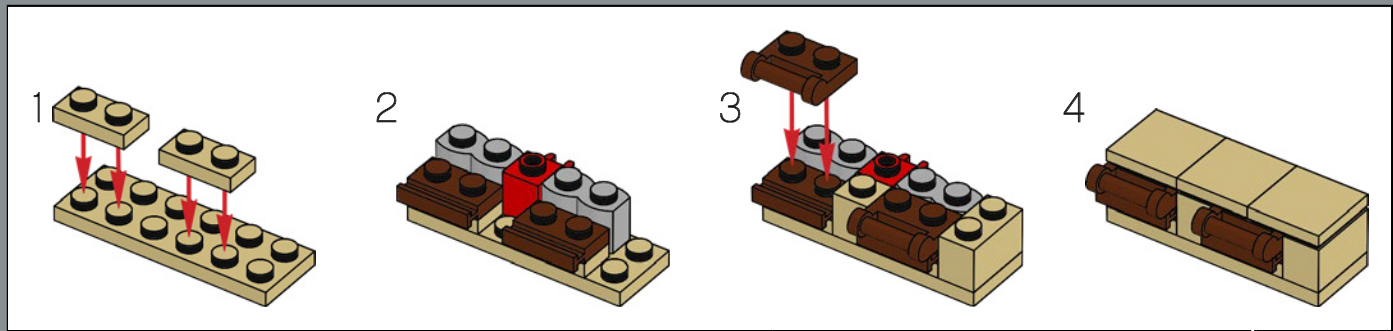



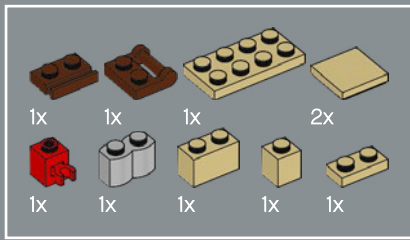

138

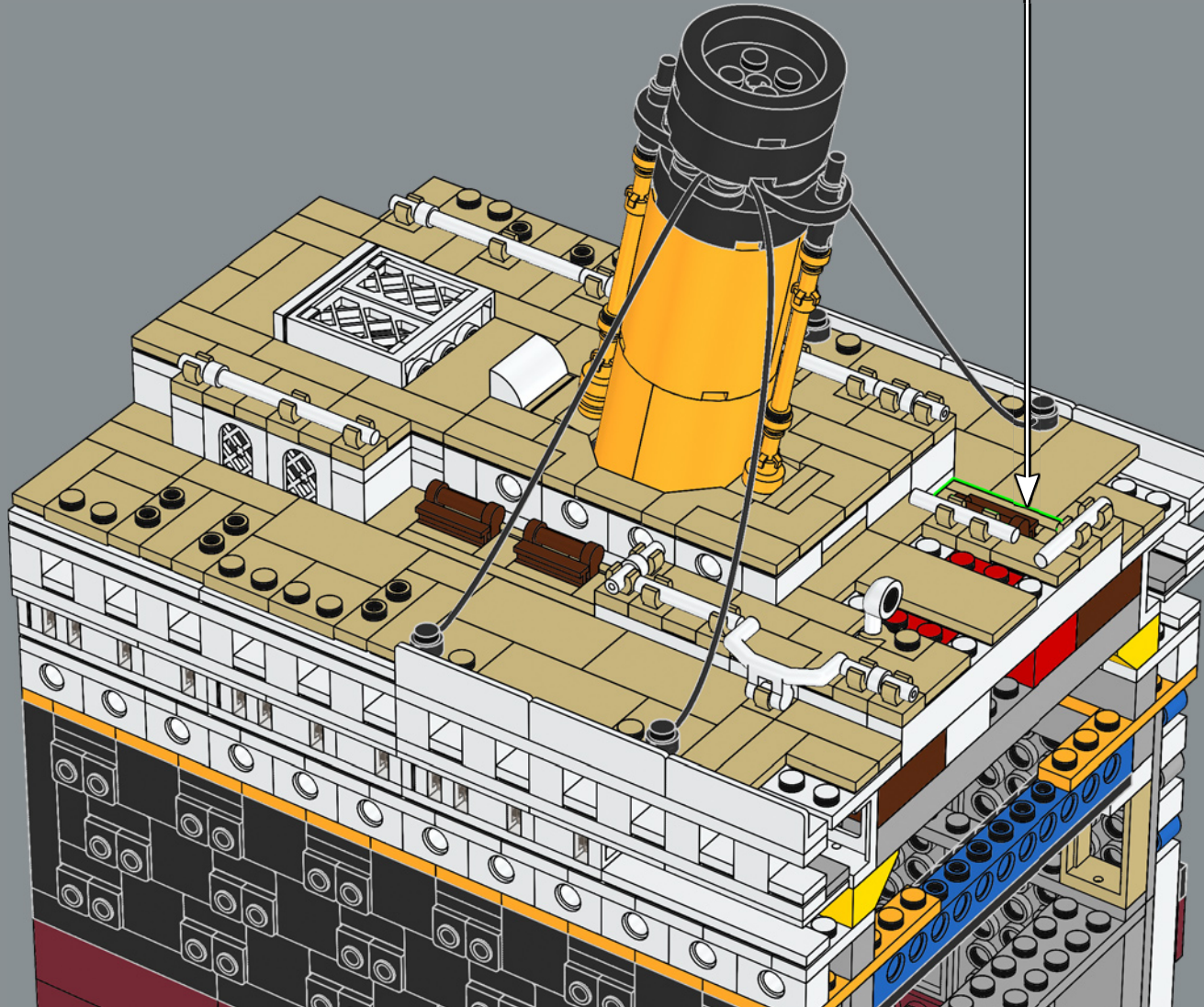
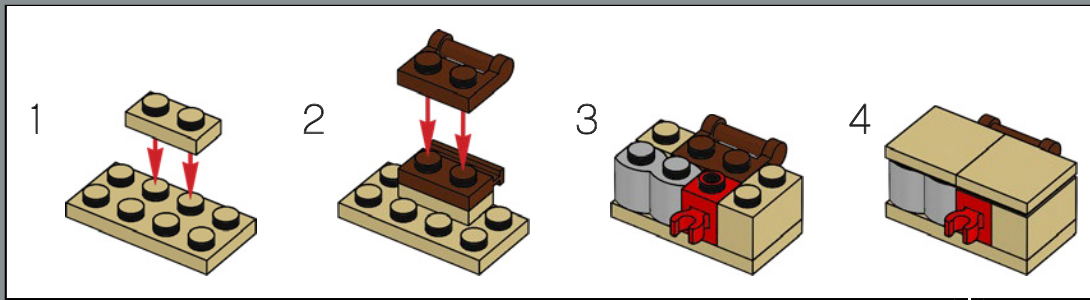

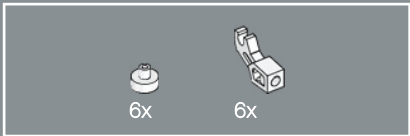

139

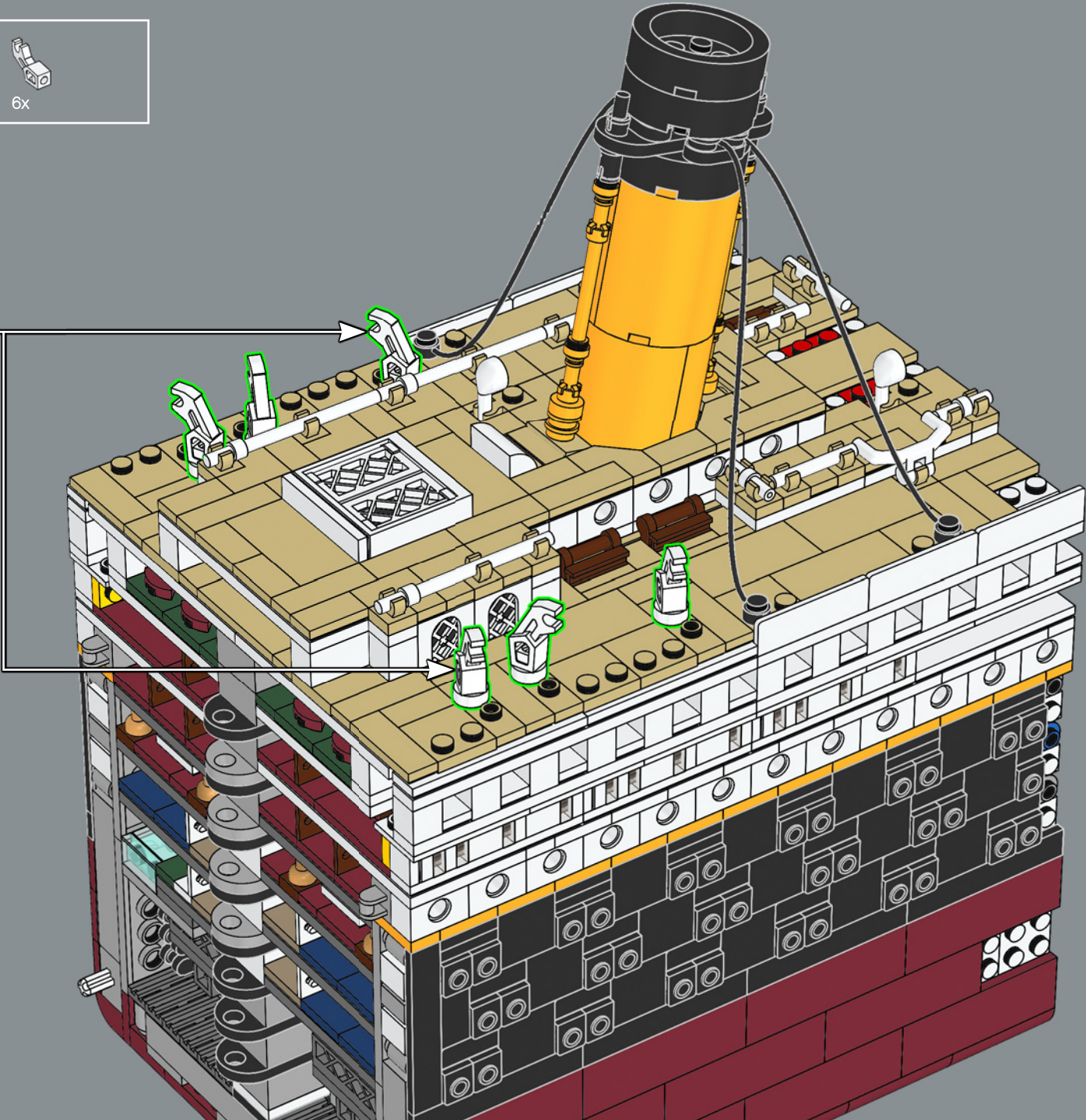
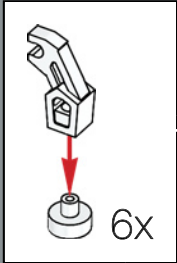

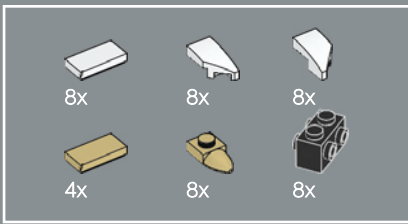

140

An Bord befanden sich 20 Rettungsboote.  
14 davon waren Holzboote mit einem  
Fassungsvermögen von jeweils 65  
Personen. Auf den vier faltbooten fanden  
jeweils 47 Personen Platz.

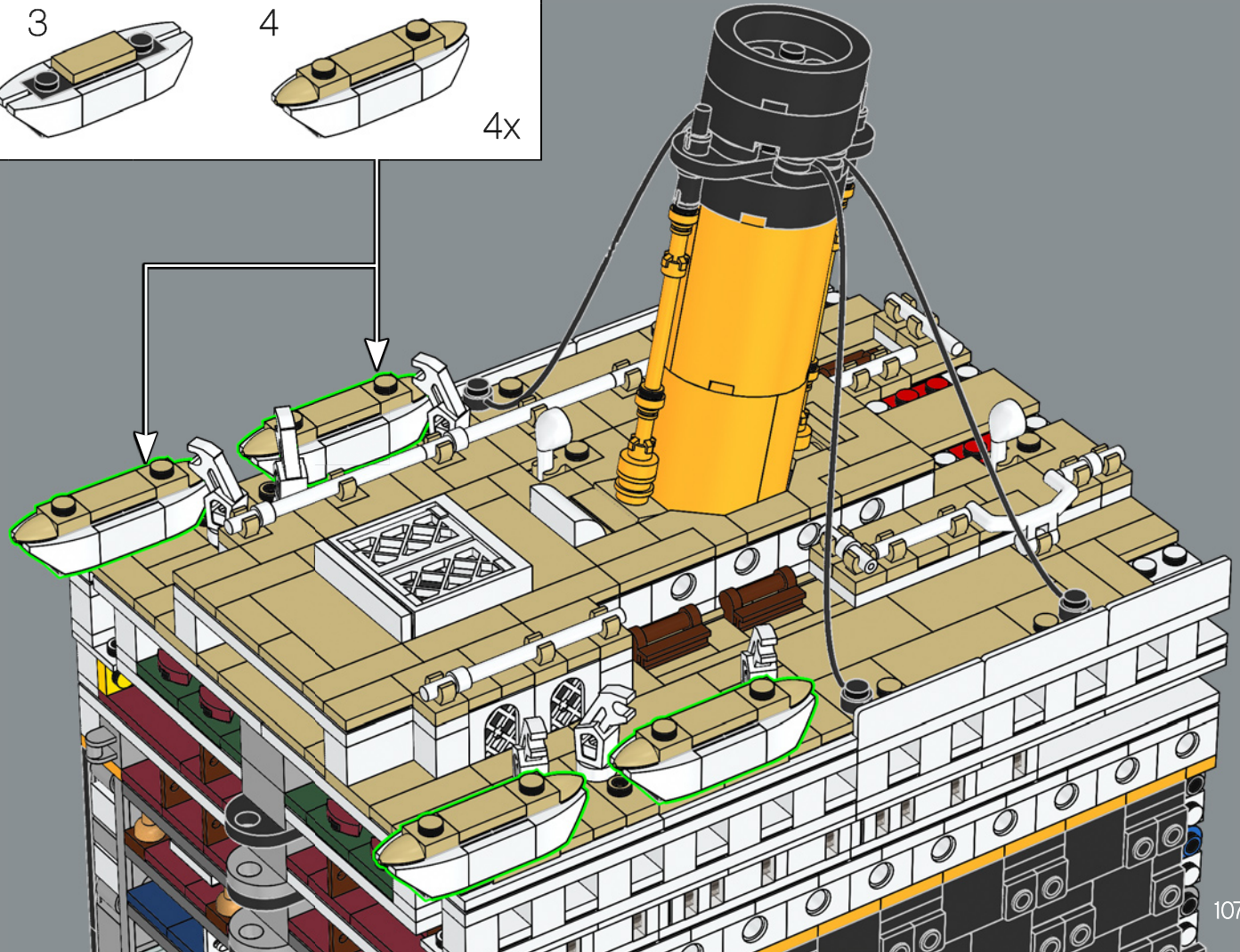
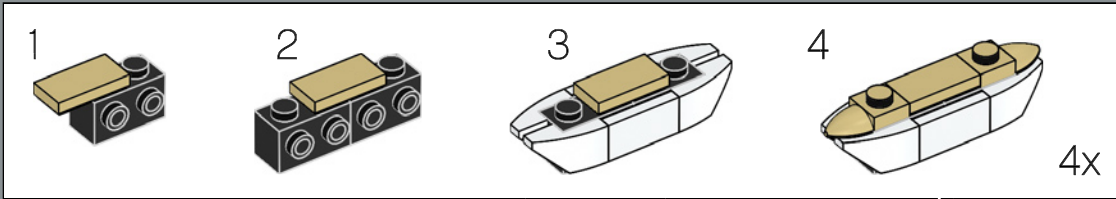

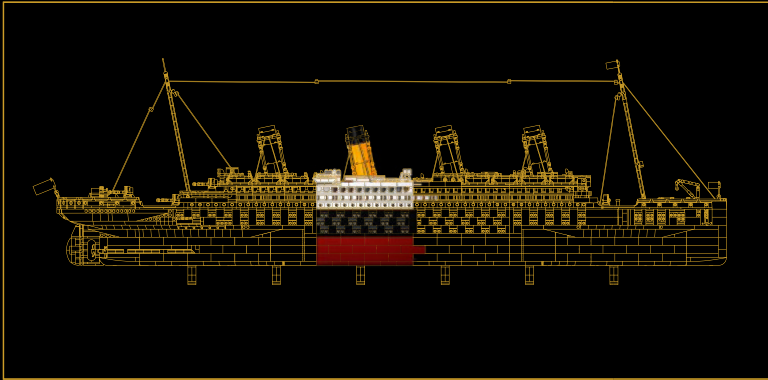

ABSCHNITT 4:

## SCHORNSTEIN & KOMPASS

Dieser Abschnitt beinhaltet einen Teil der gewaltigen Maschinenräume auf der *Titanic* sowie den erhöhten Bereich in der Mitte des Aufbaus, der den Hauptkompass beherbergte. Diese höhere Position sollte sicherstellen, dass der Kompass möglichst wenig von der gewaltigen Eisenmasse des Rumpfes beeinträchtigt wurde. Eine kleinere Baugruppe stellt eine Bank dar, auf der die Passagiere den Blick auf die Oberdecks genossen.



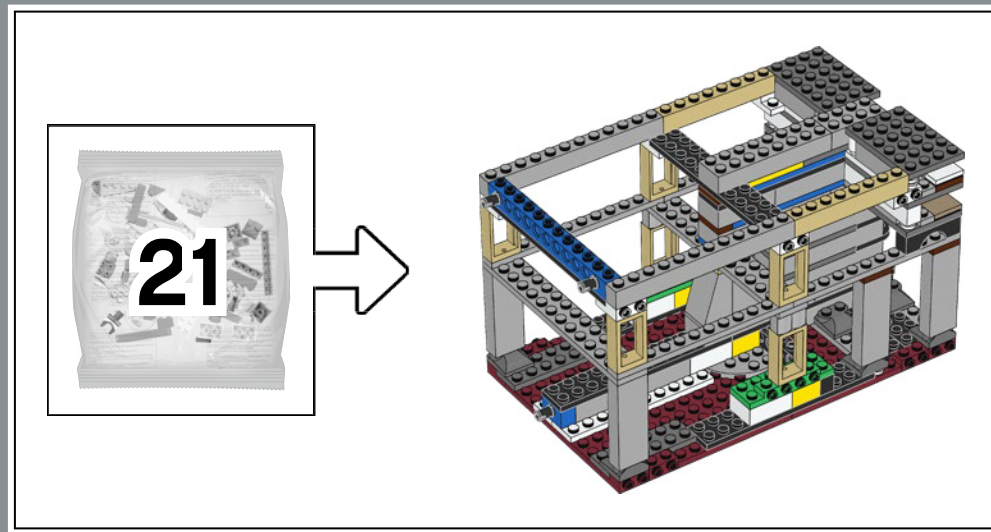

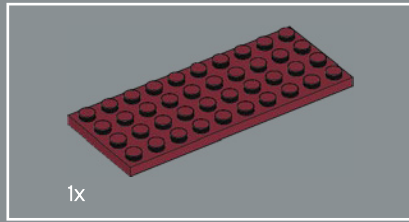
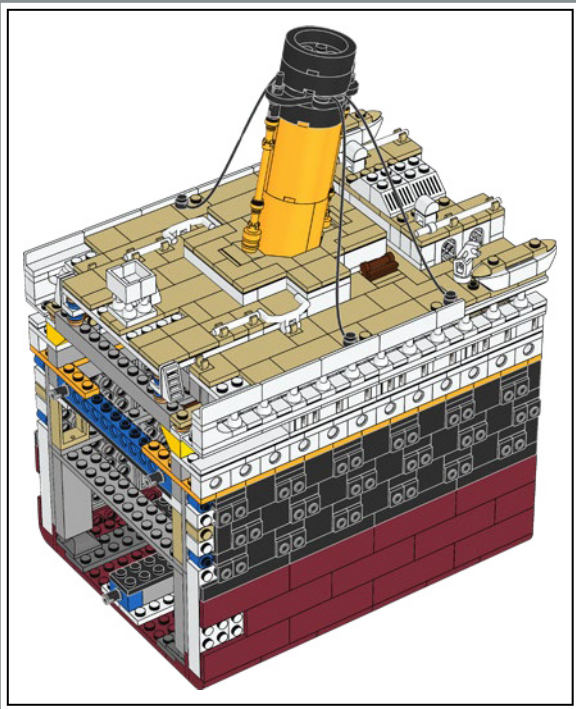

141

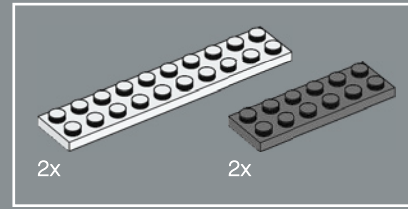
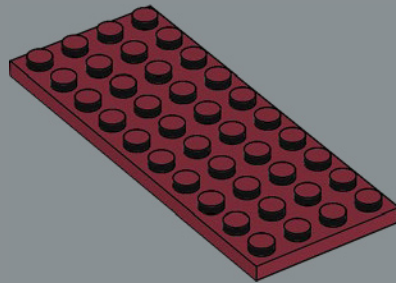

142

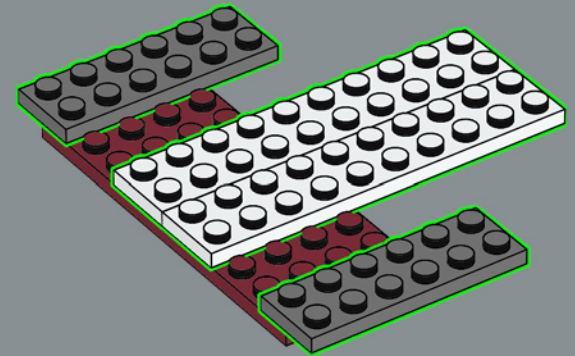

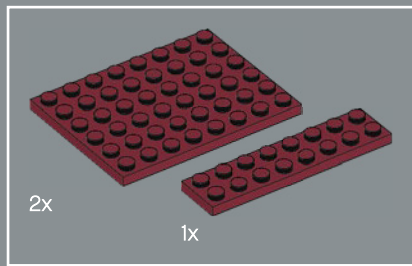

143

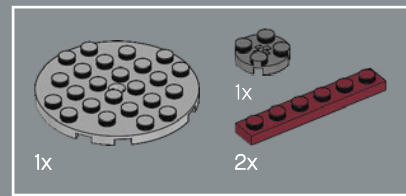
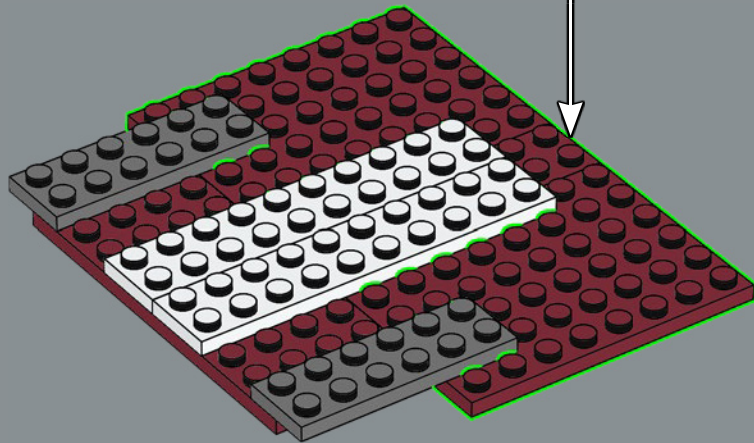
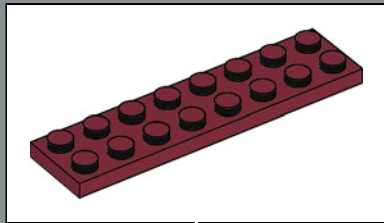

144

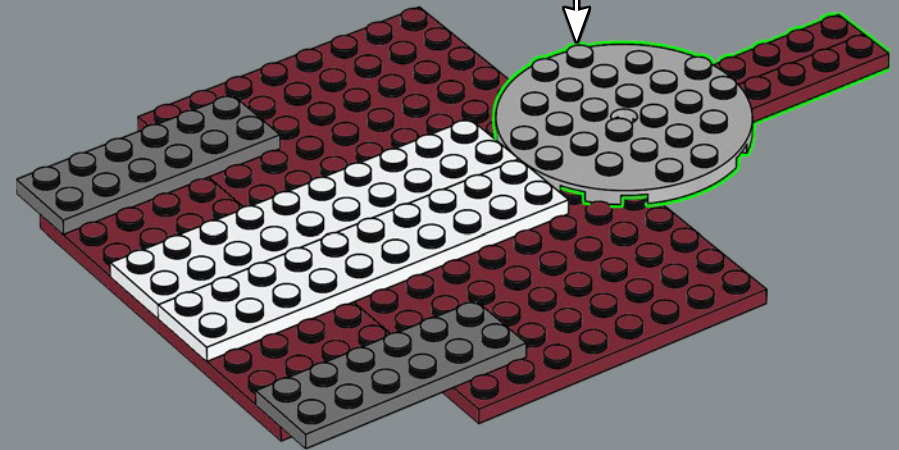
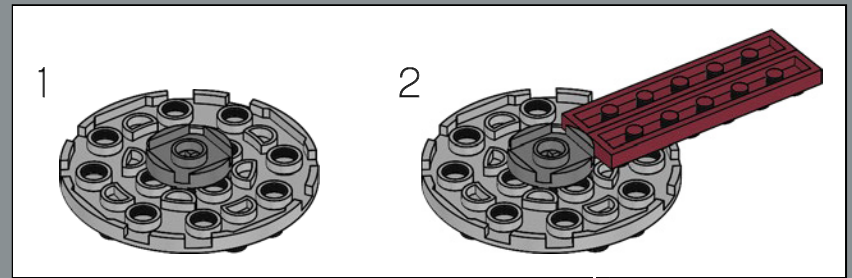

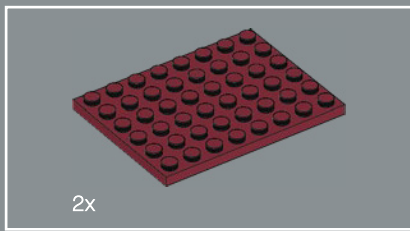

145

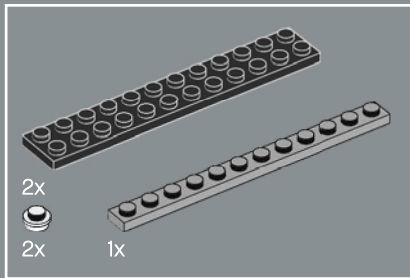
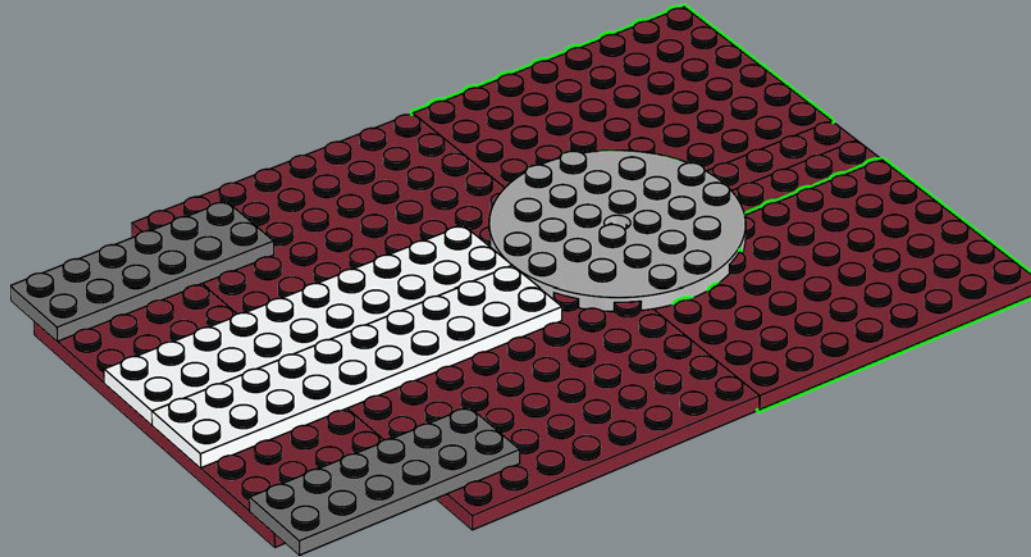

146

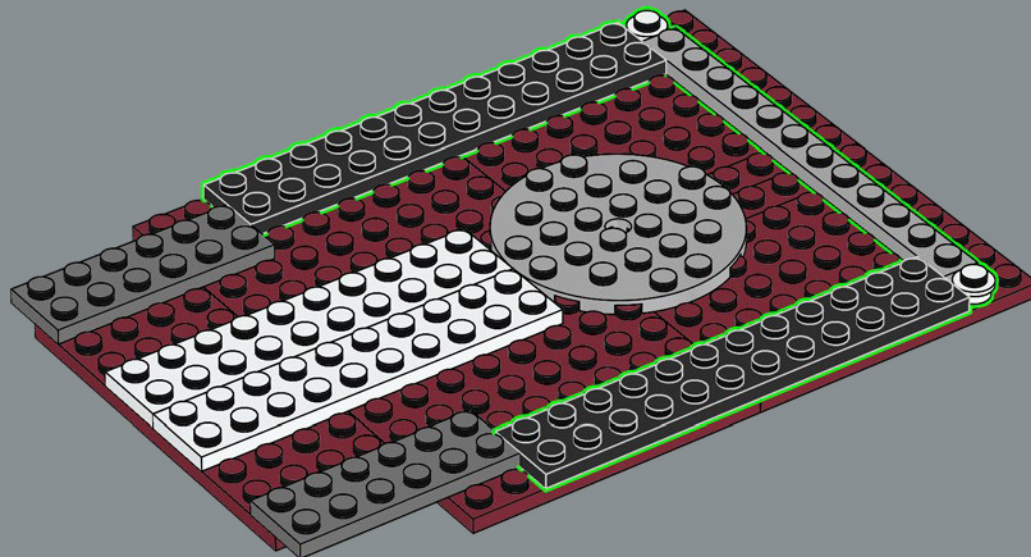



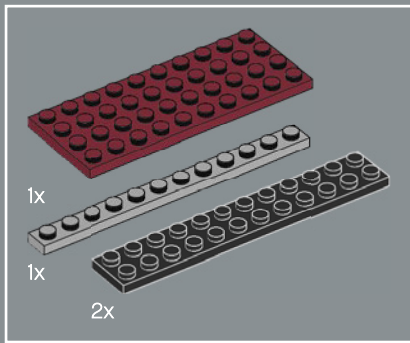

147

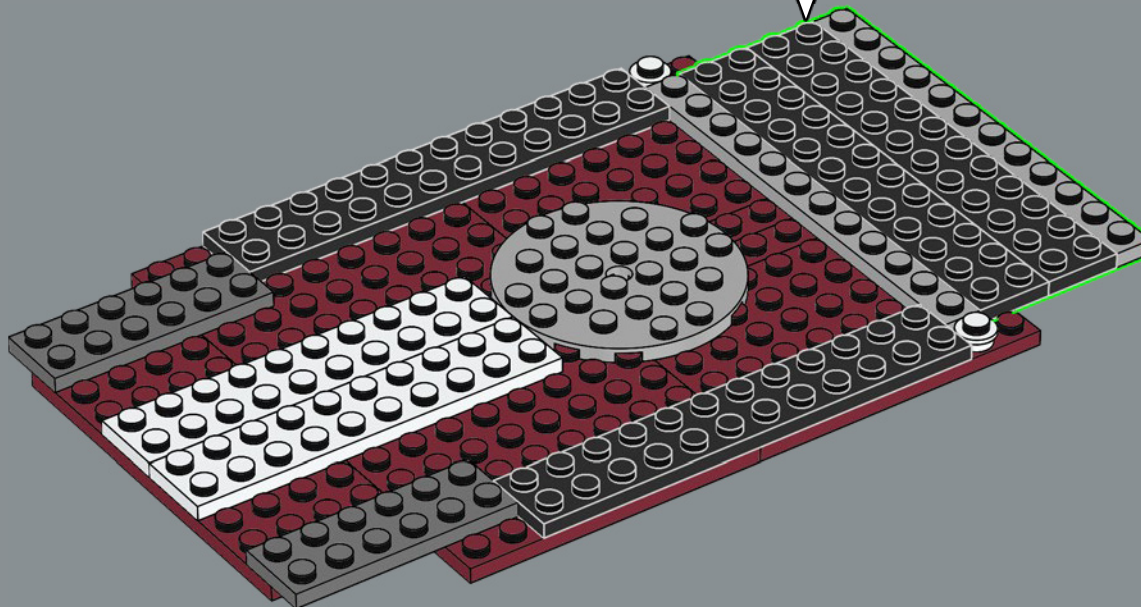
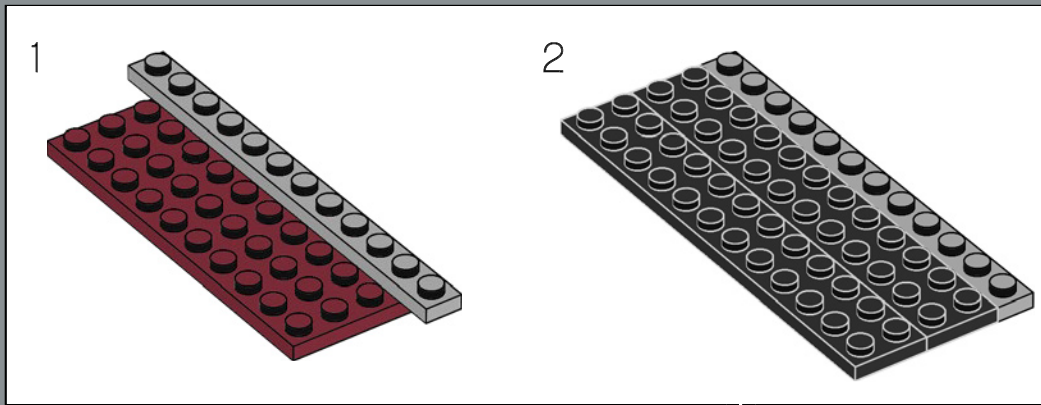



148

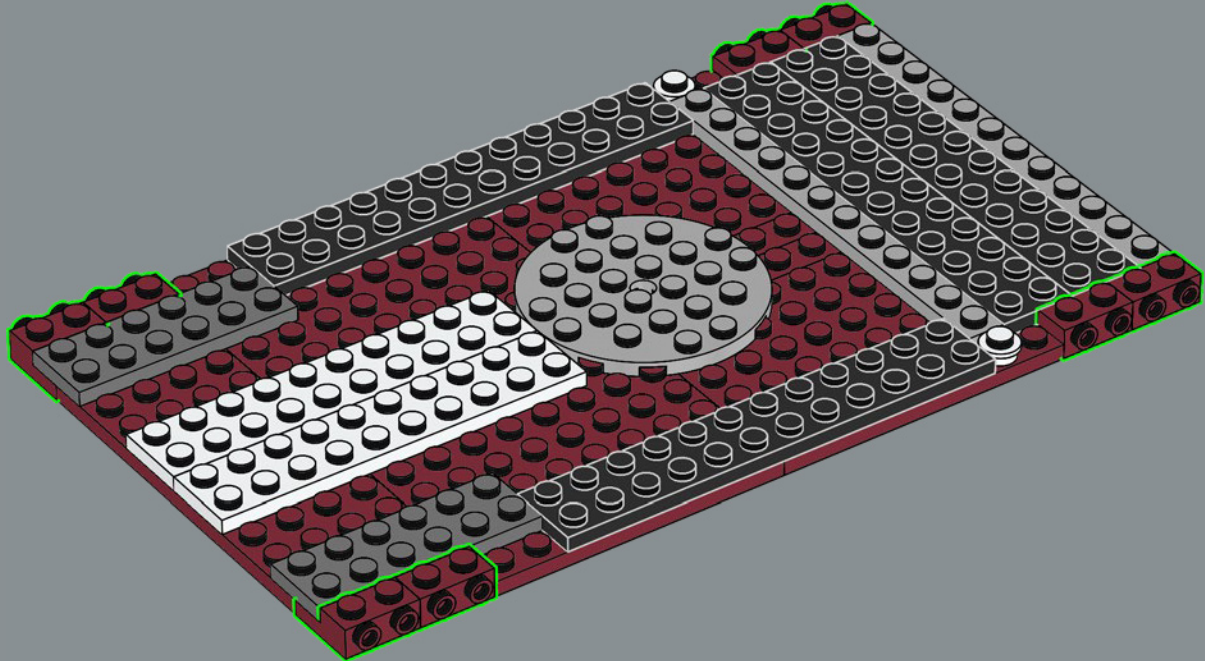

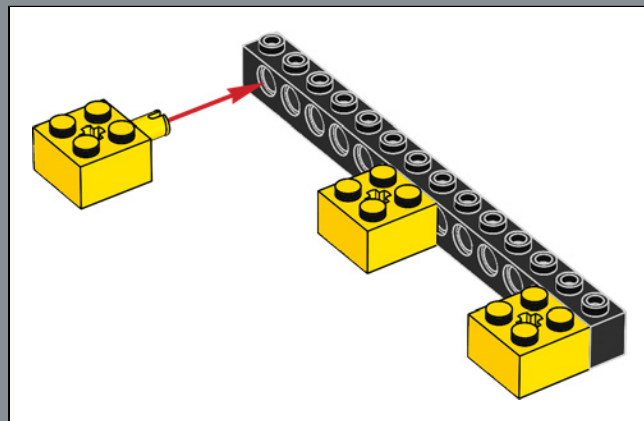
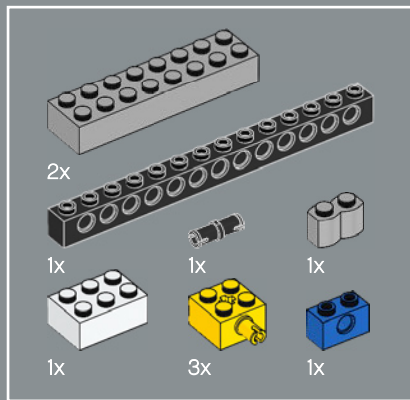

149

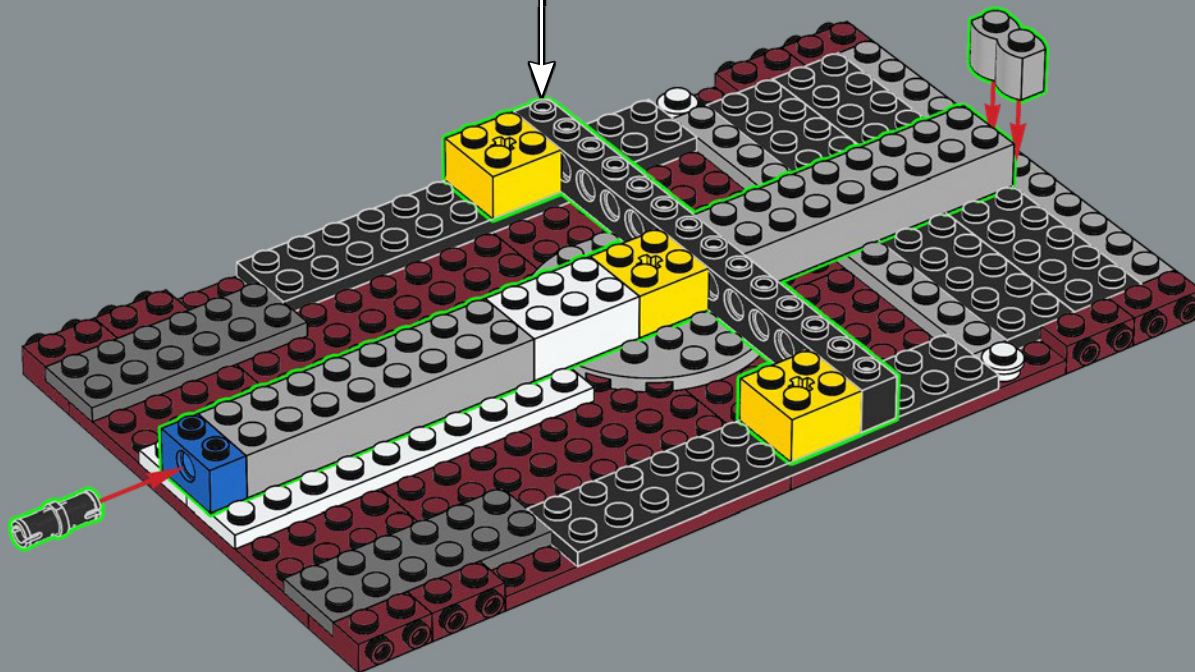

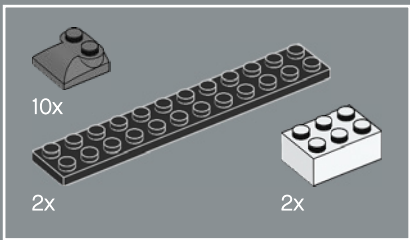

150

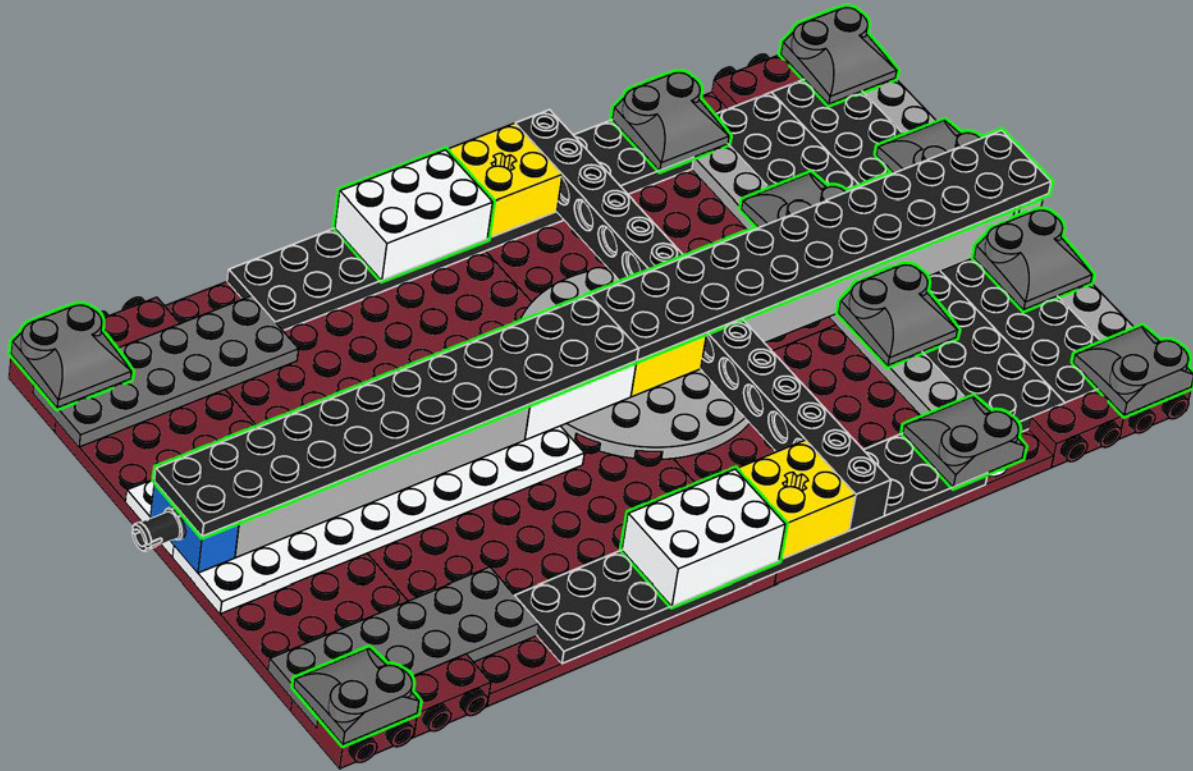

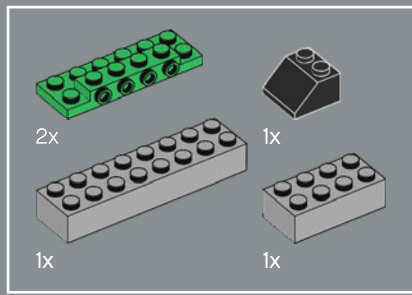

151

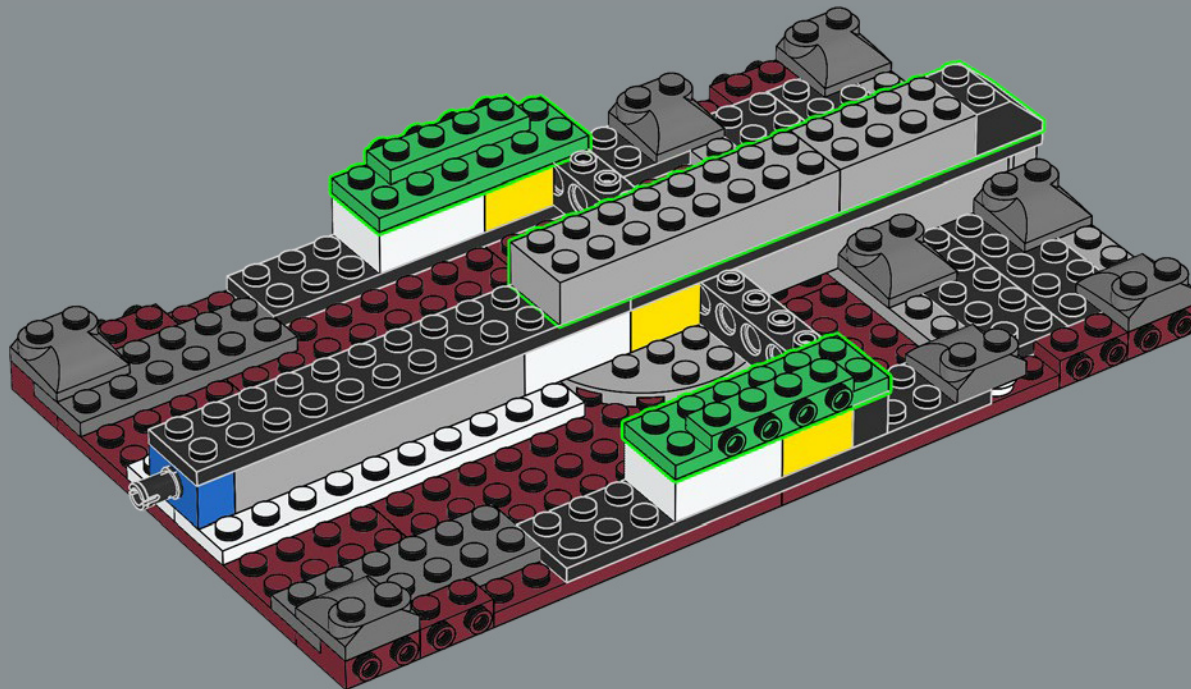

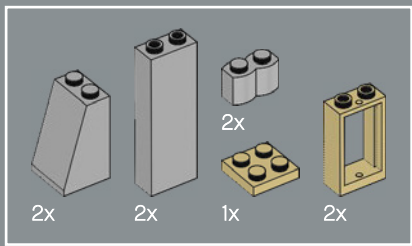

152

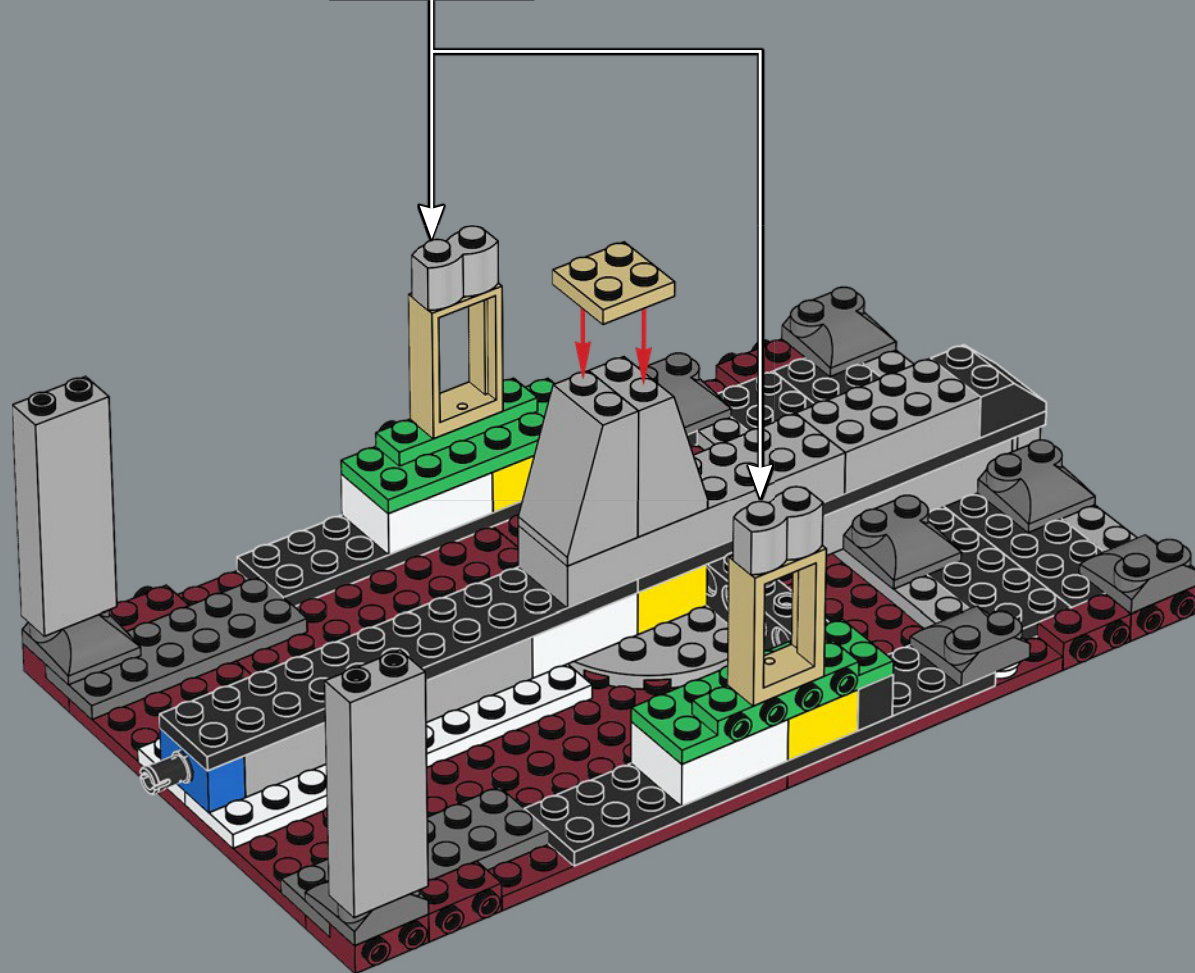
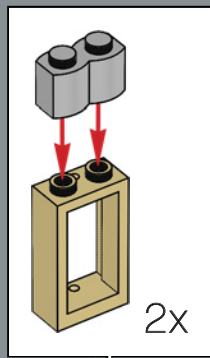

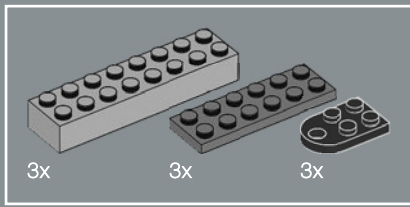

153

1

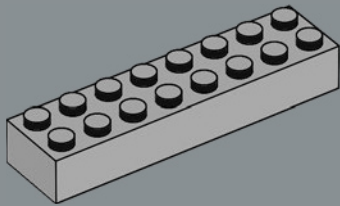

2

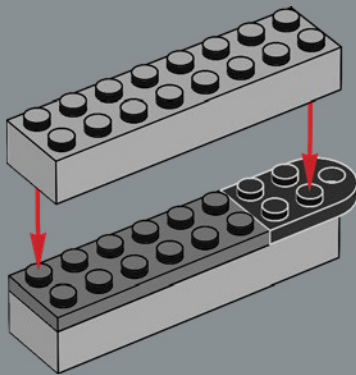

3

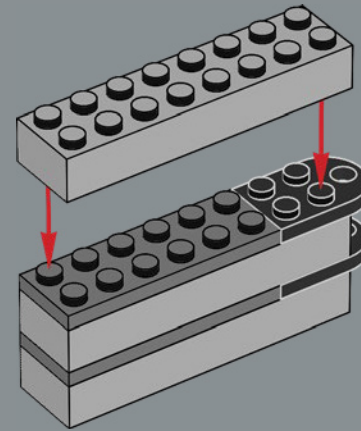

4

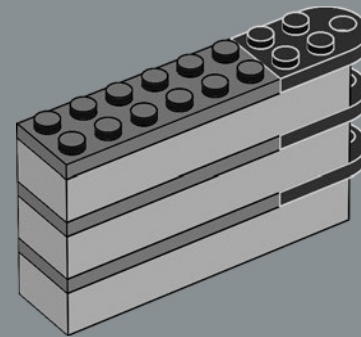

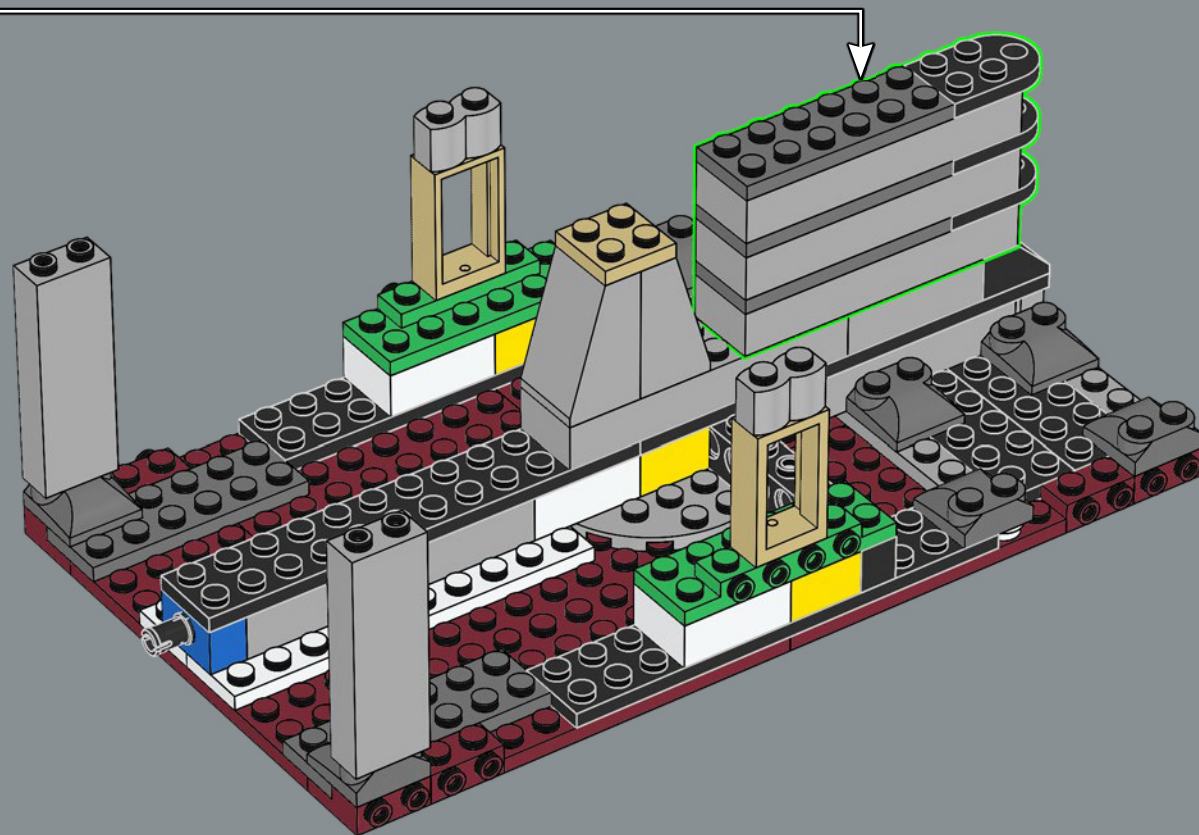



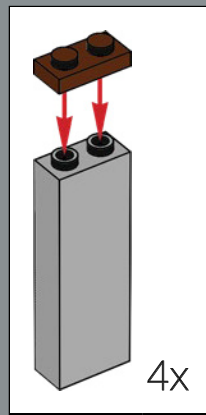
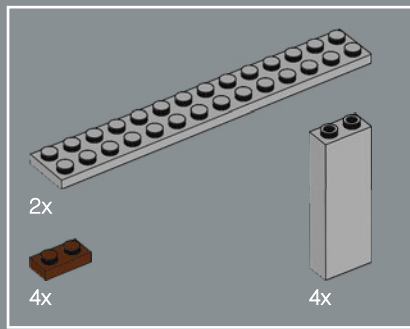

154

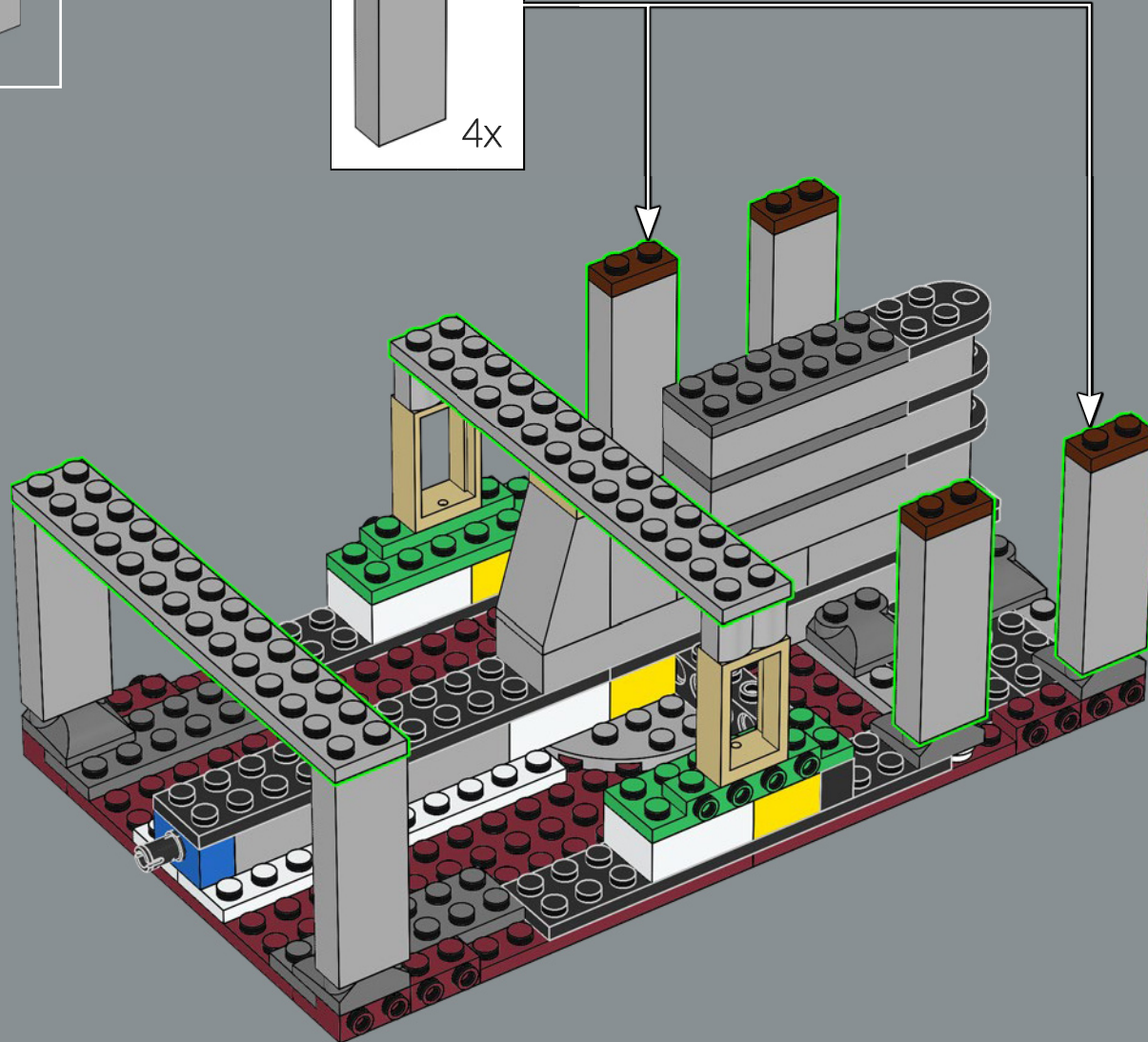

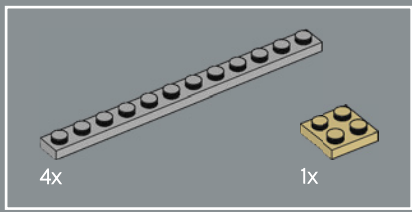

155

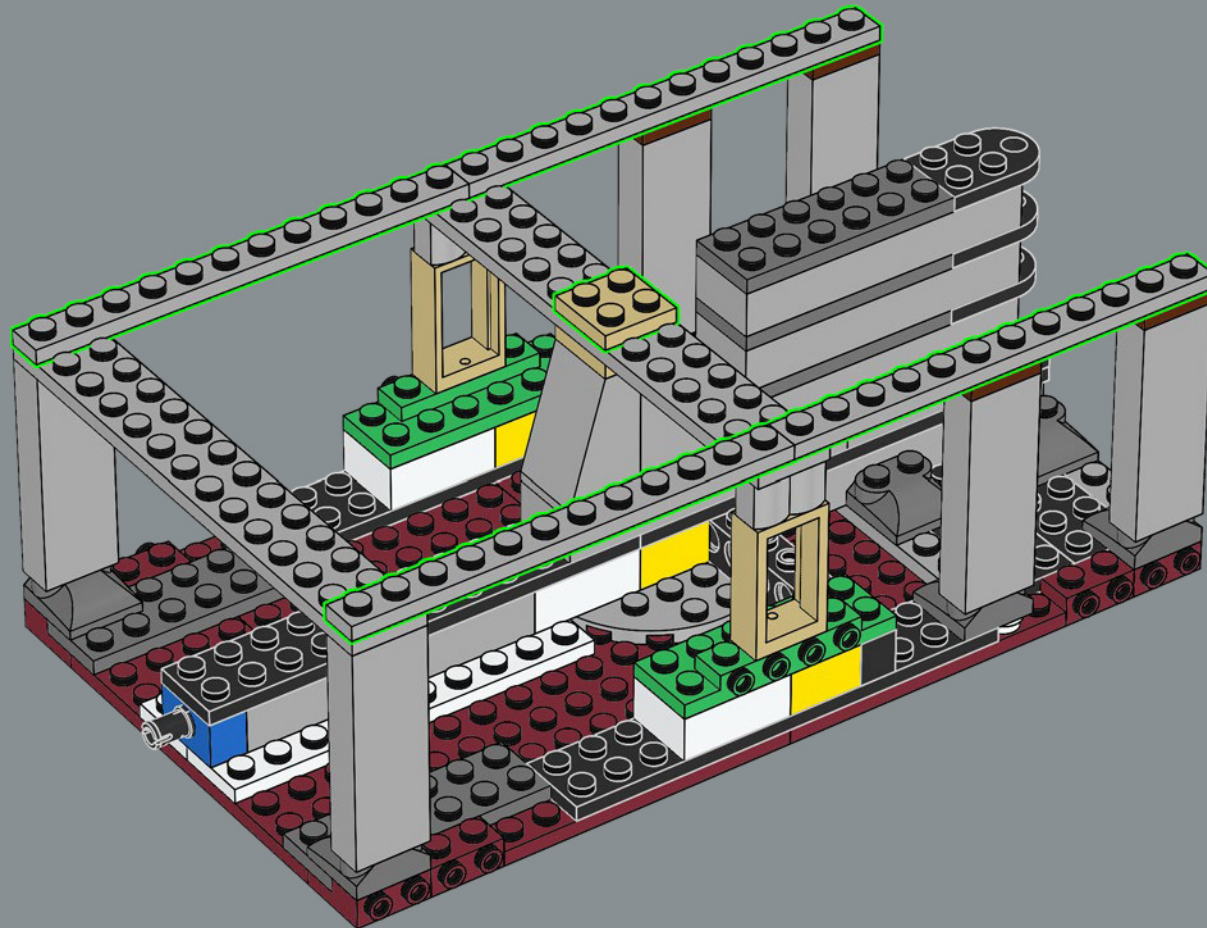

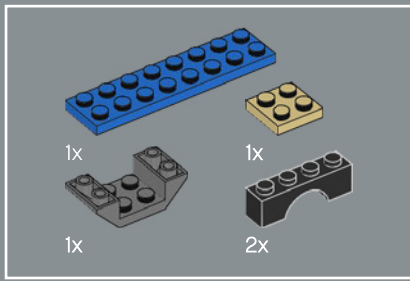

156

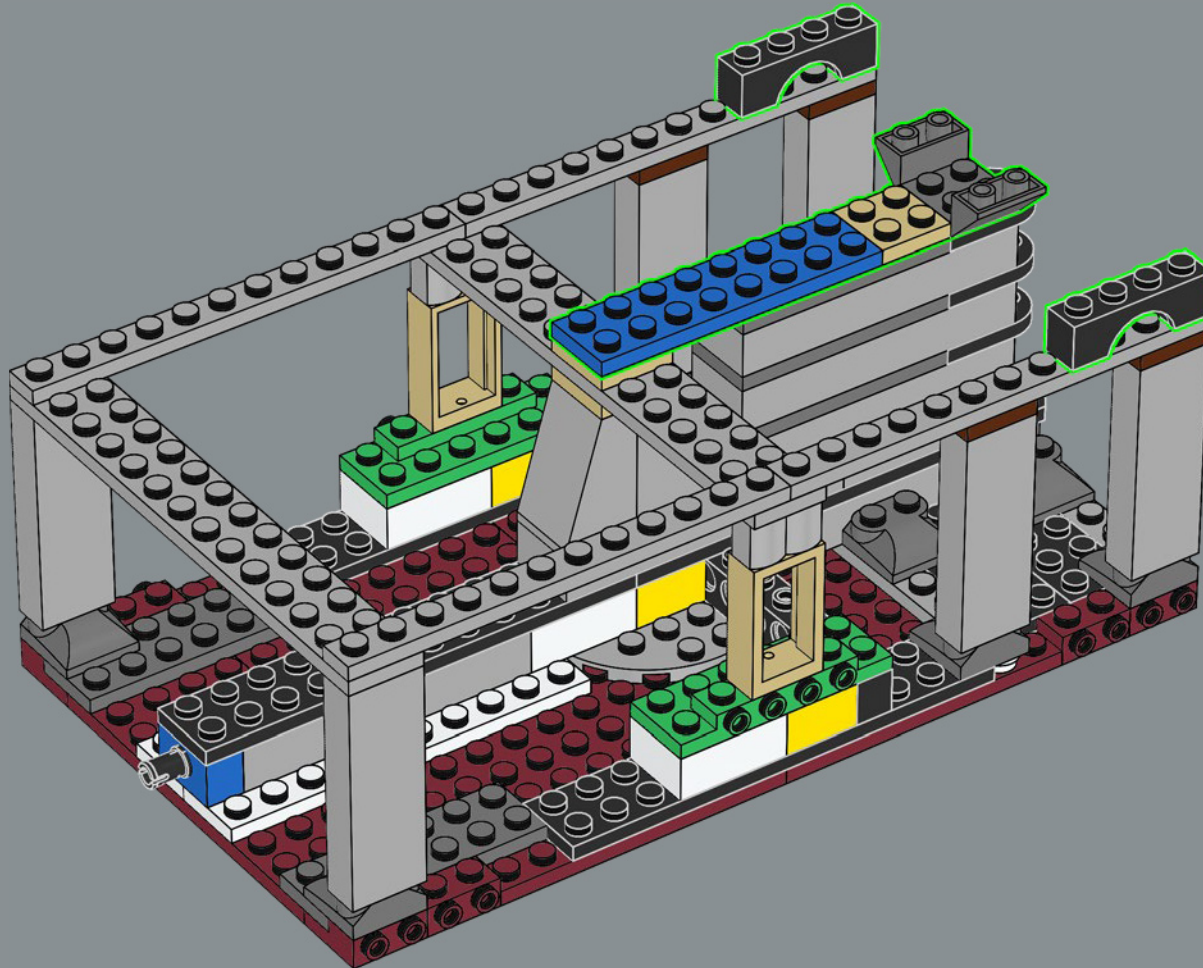

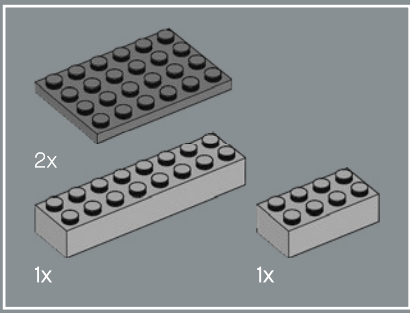

157

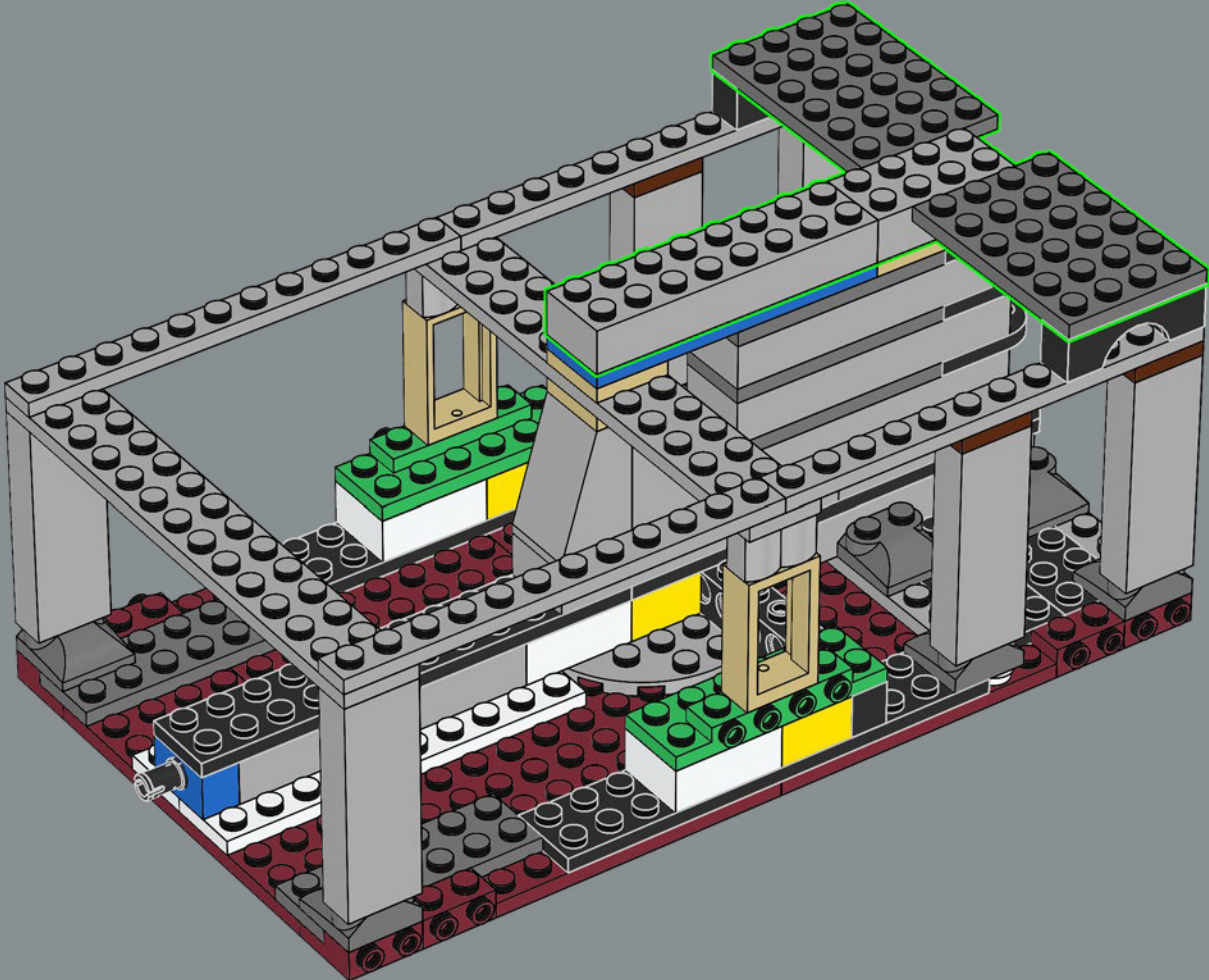

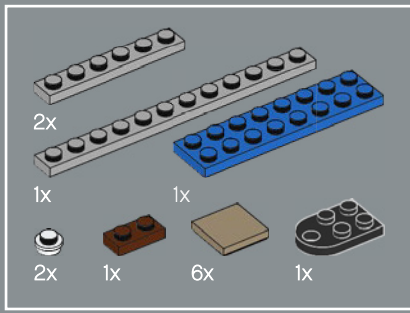

158

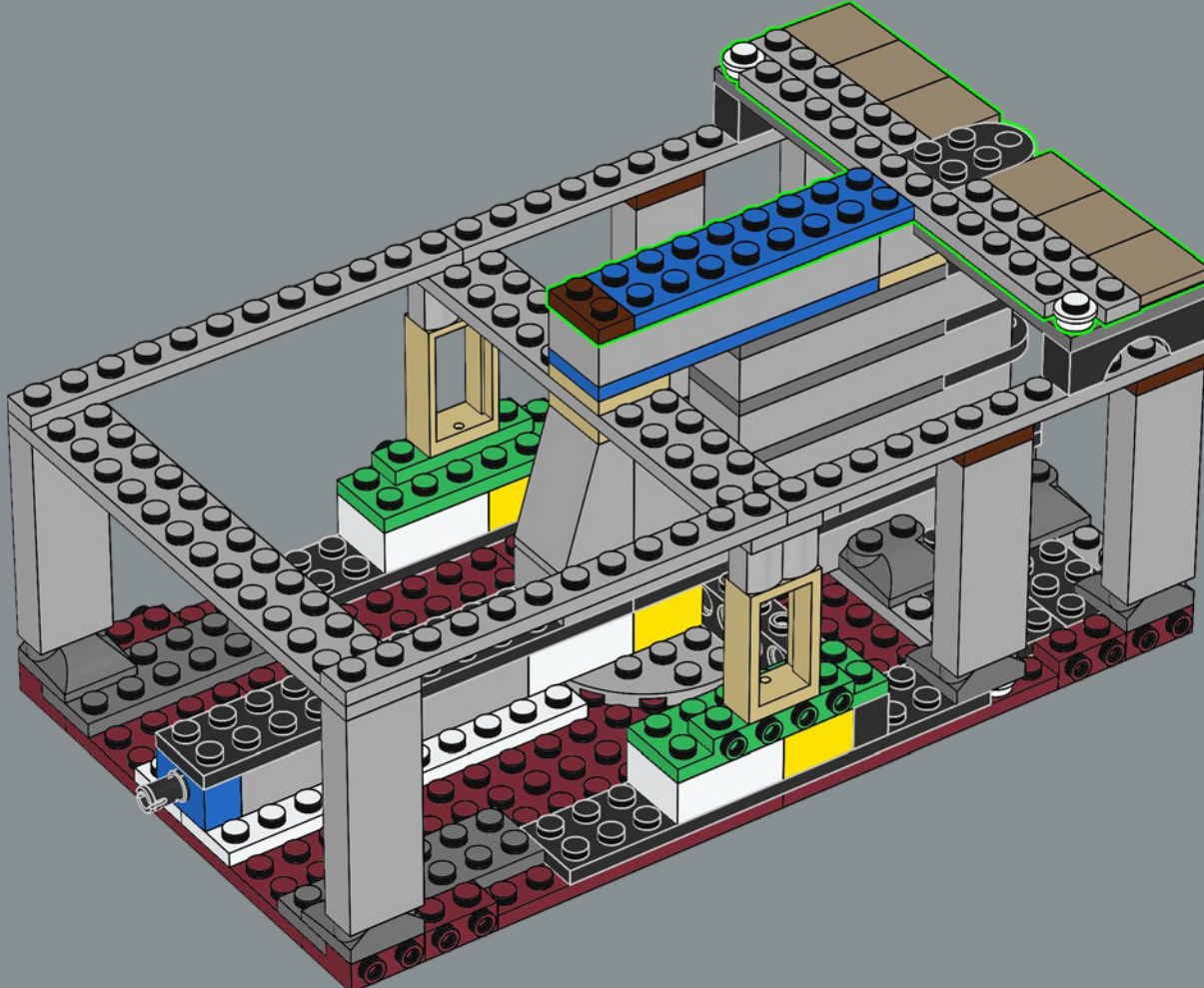

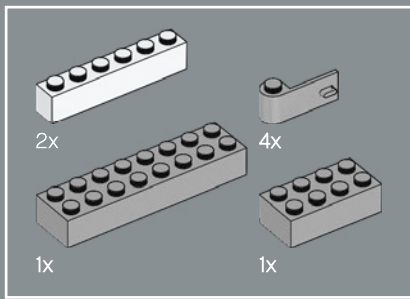

159

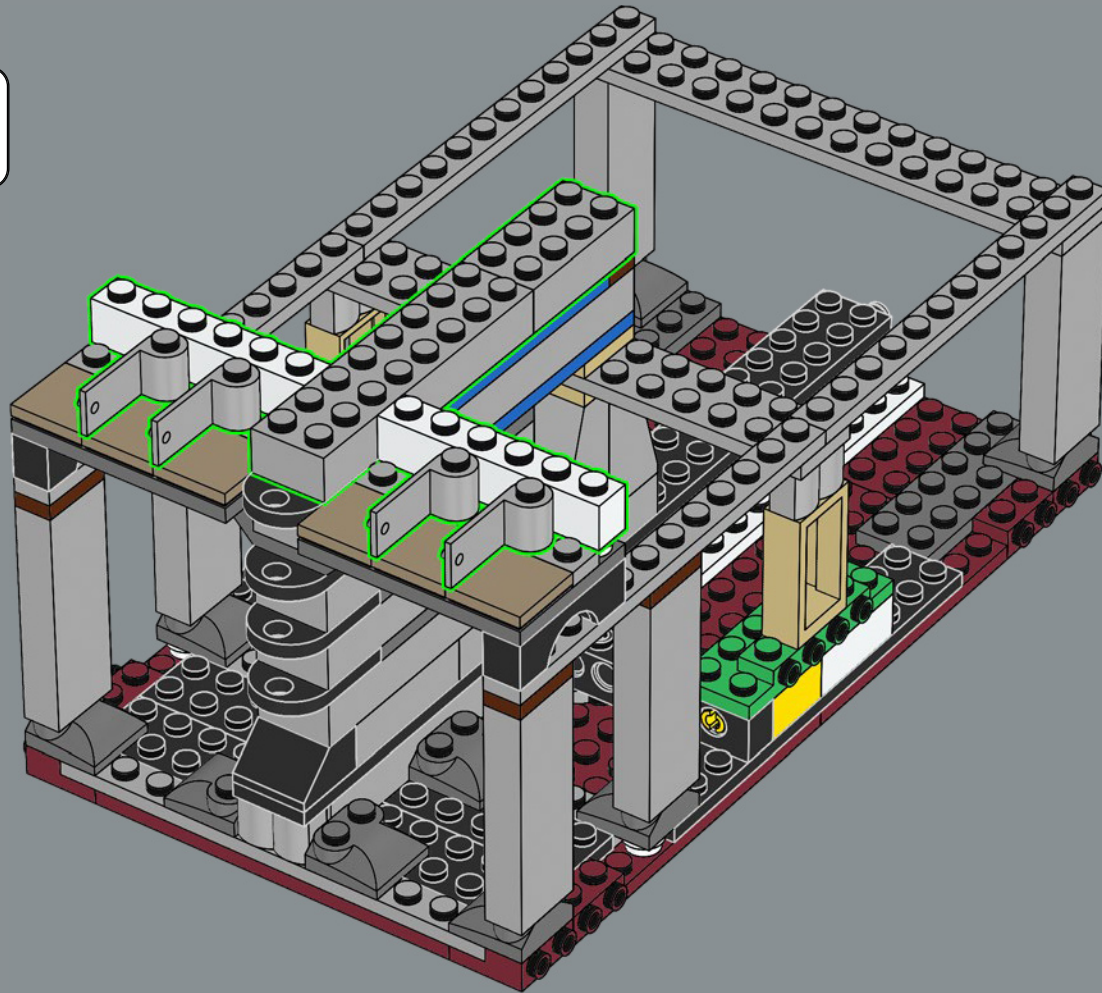

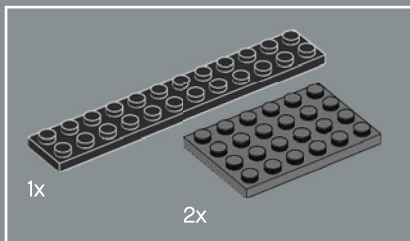

160

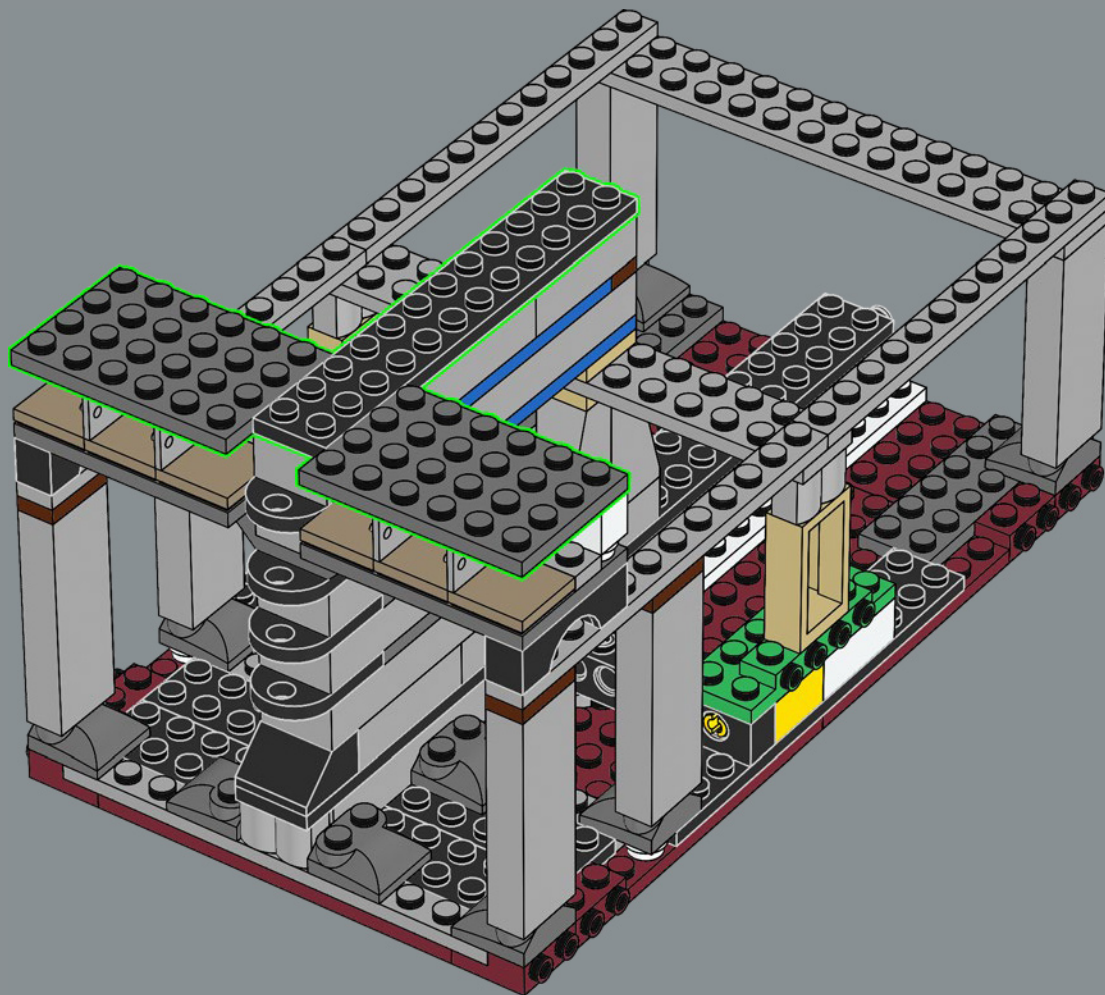

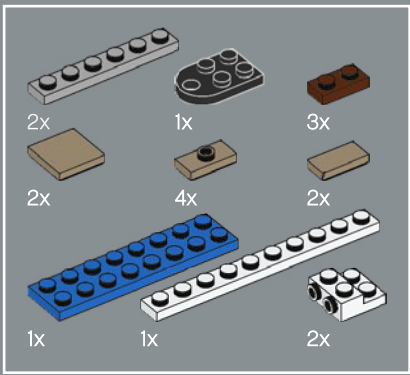

161

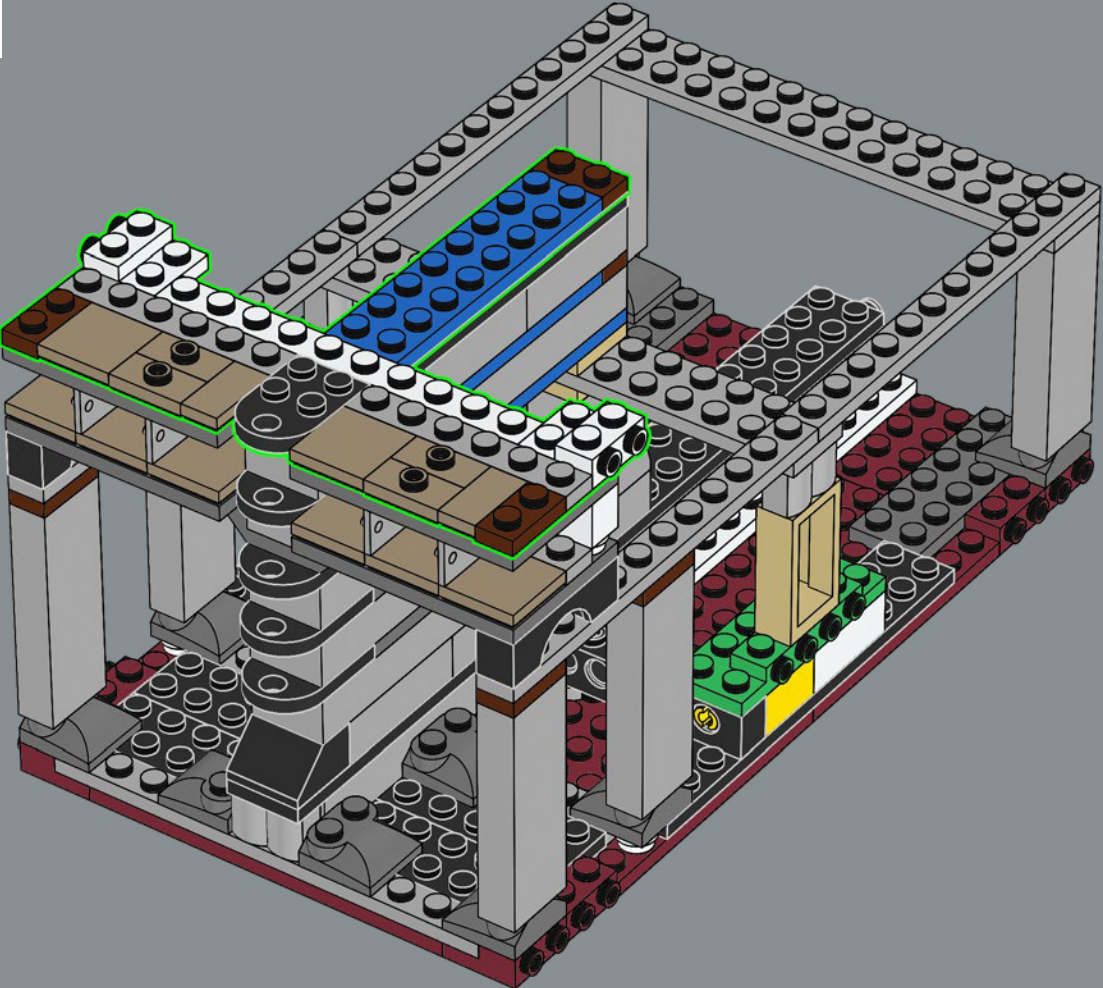



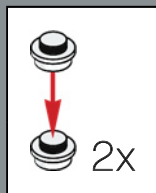
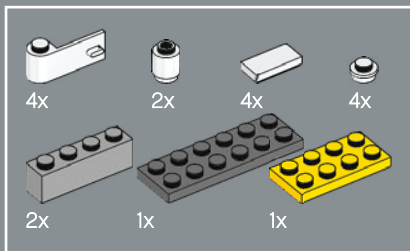

162

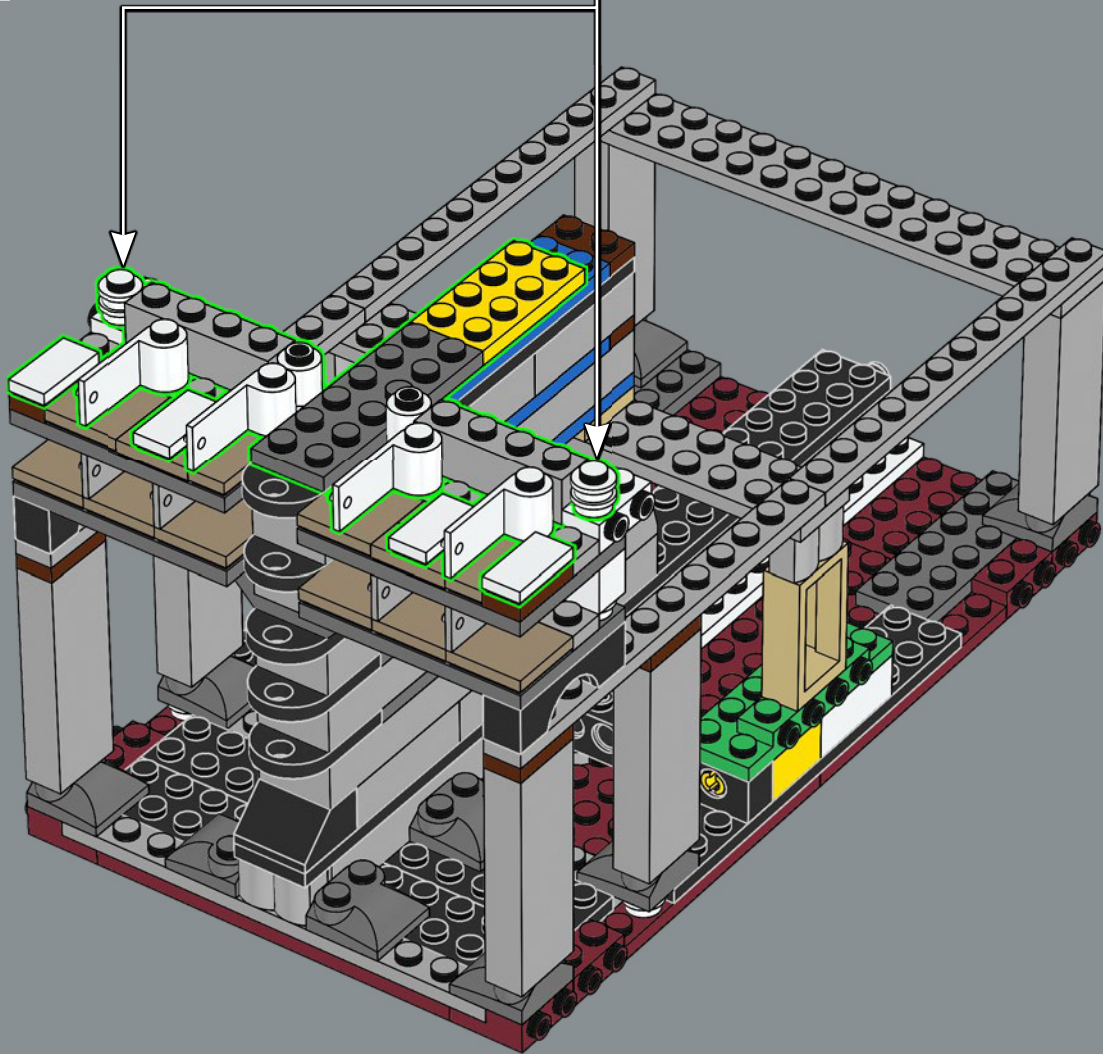

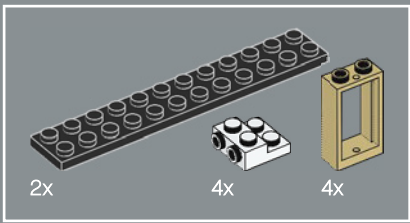

163

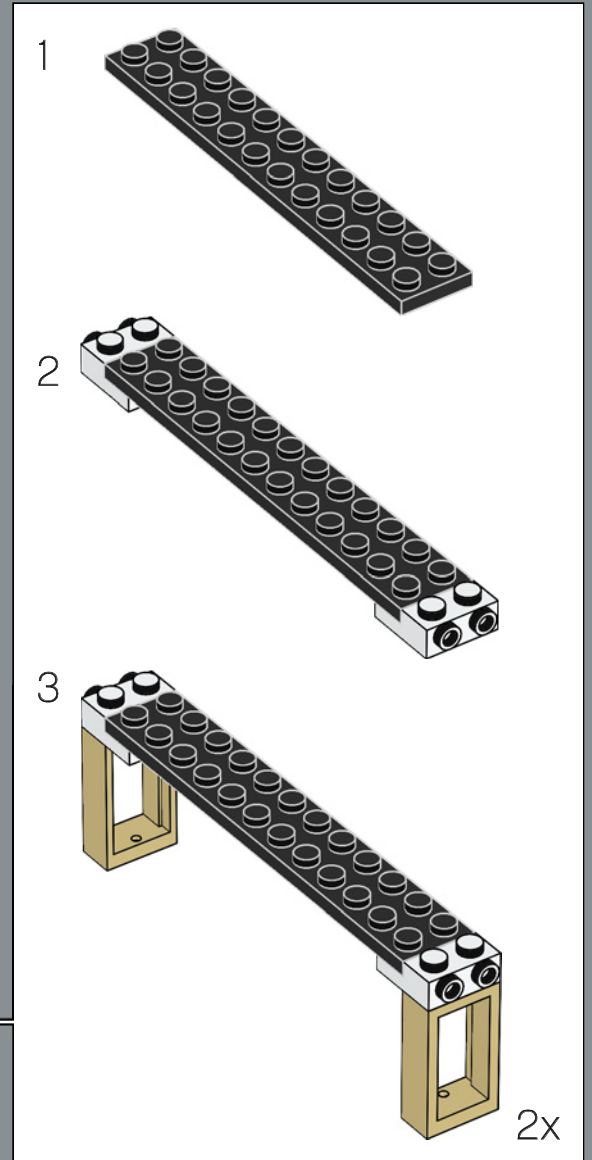
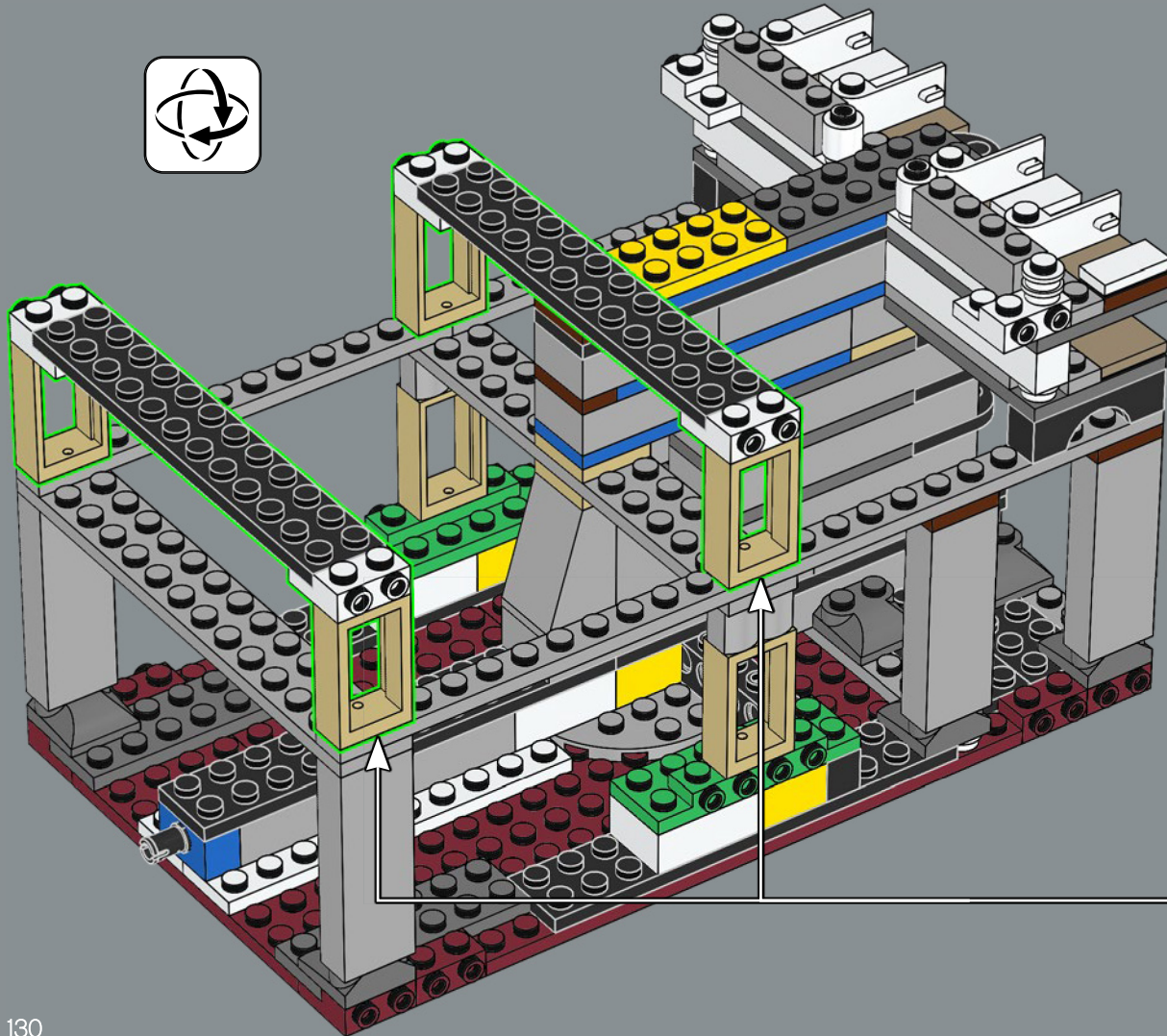

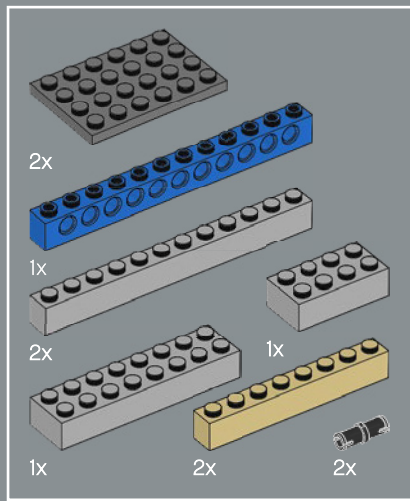

164

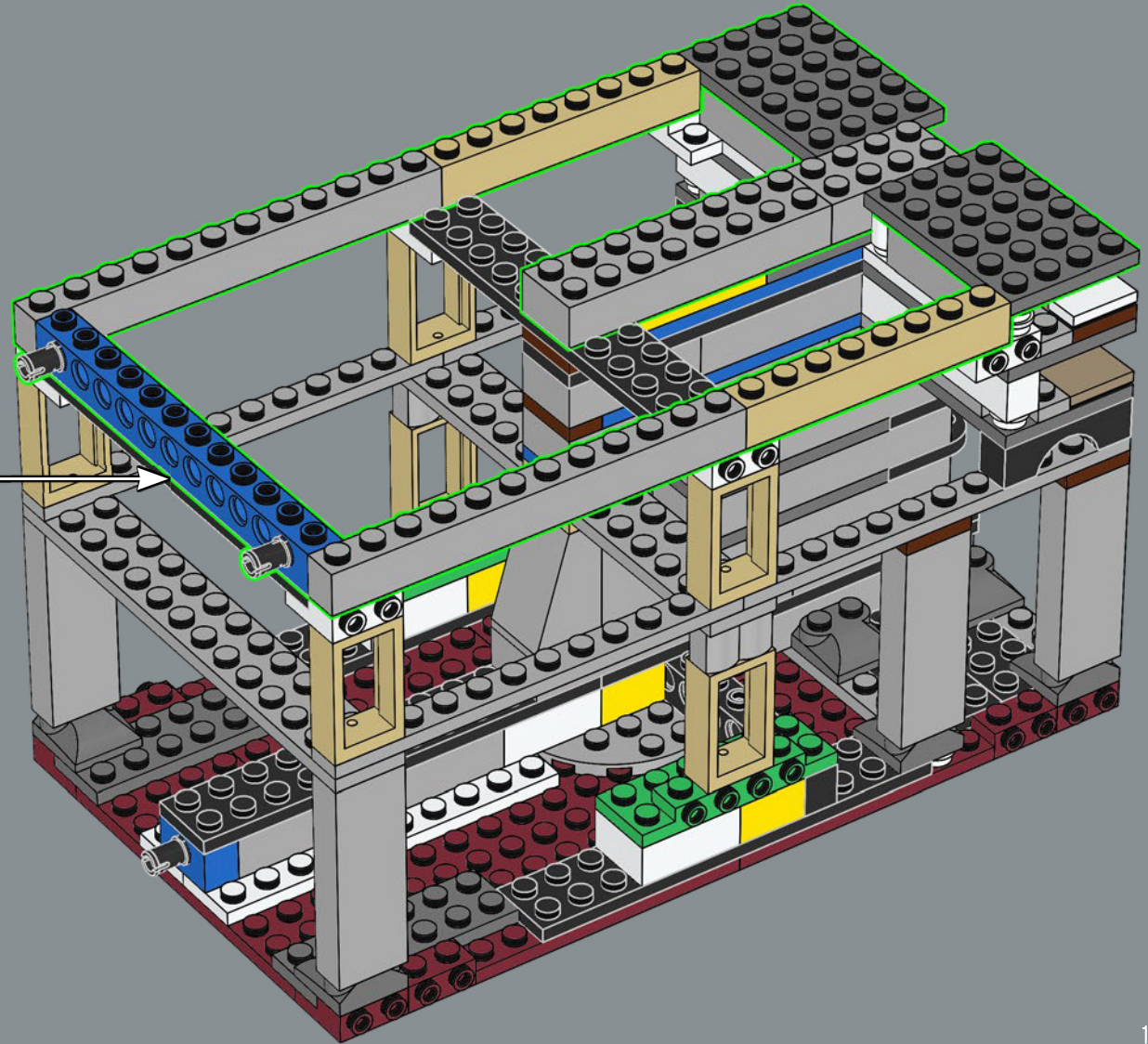
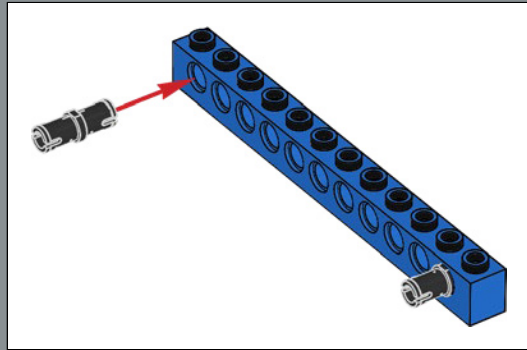

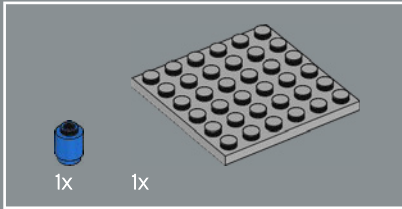
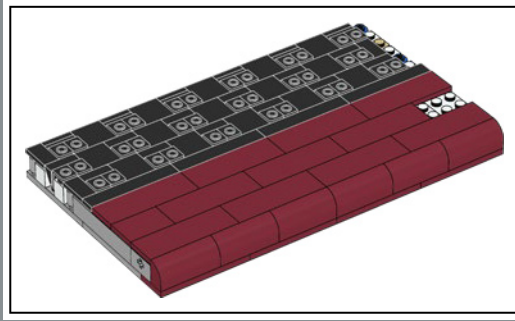
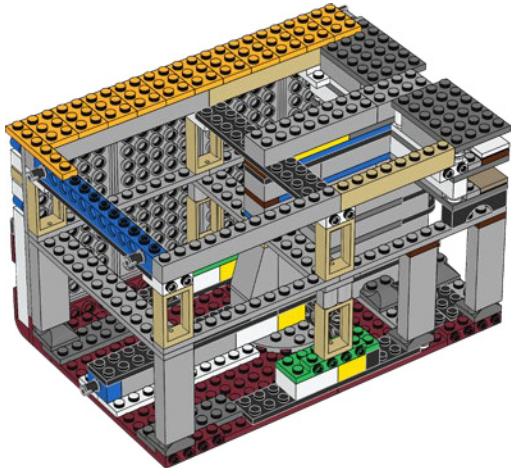
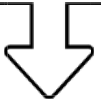

165

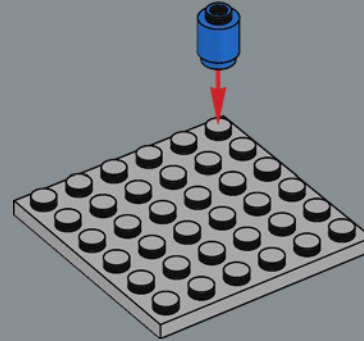

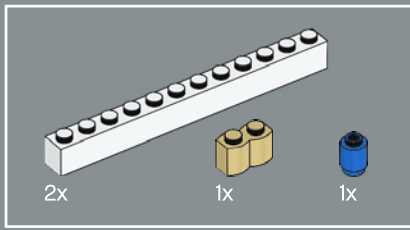

166

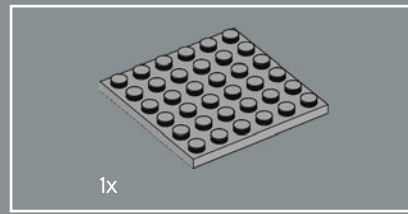
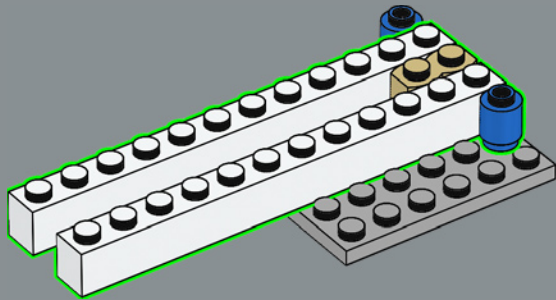

167

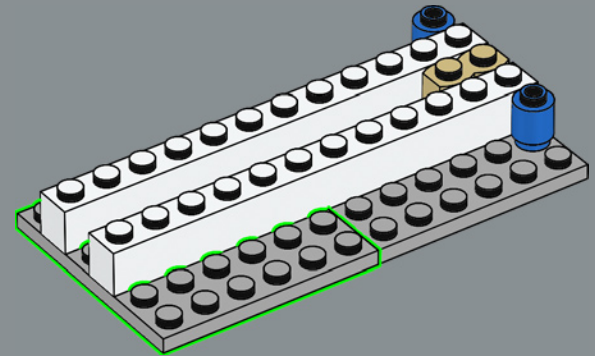

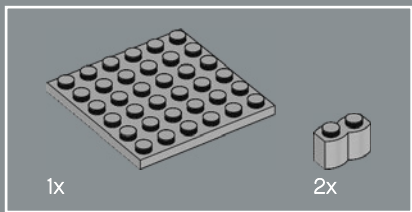

168

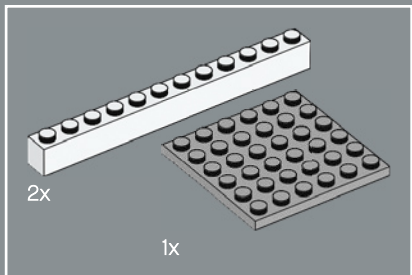
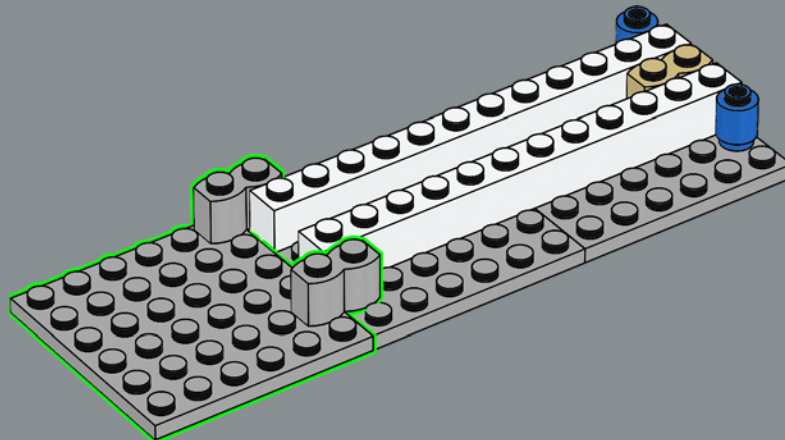

169

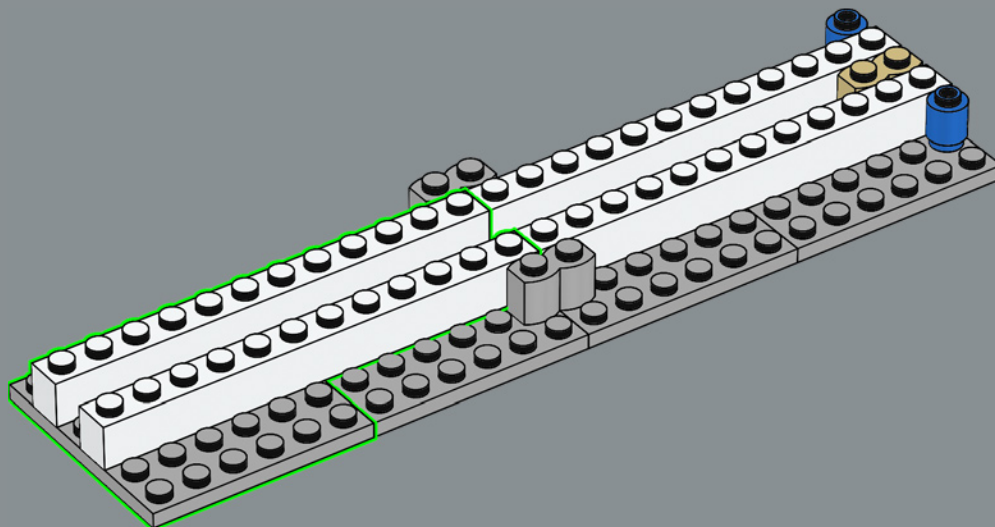



170

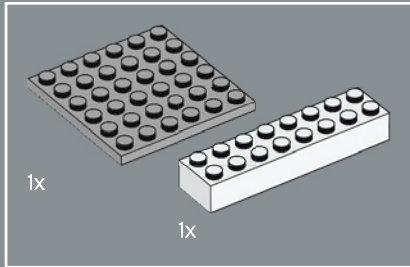
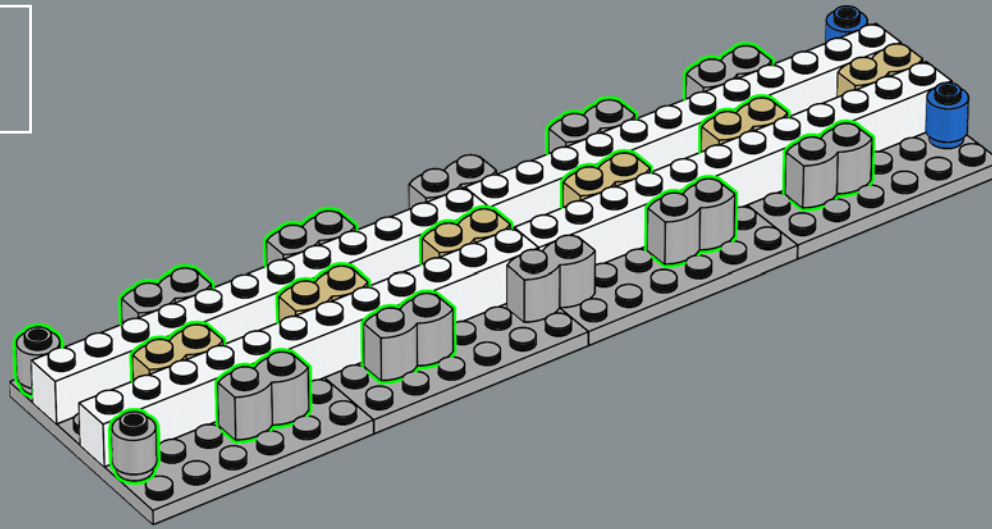

171

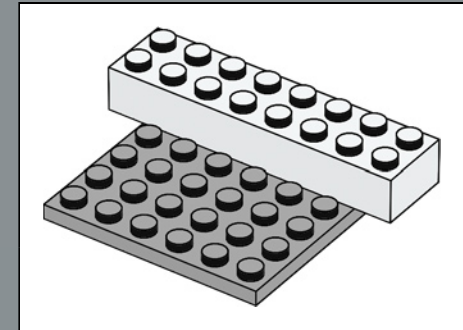
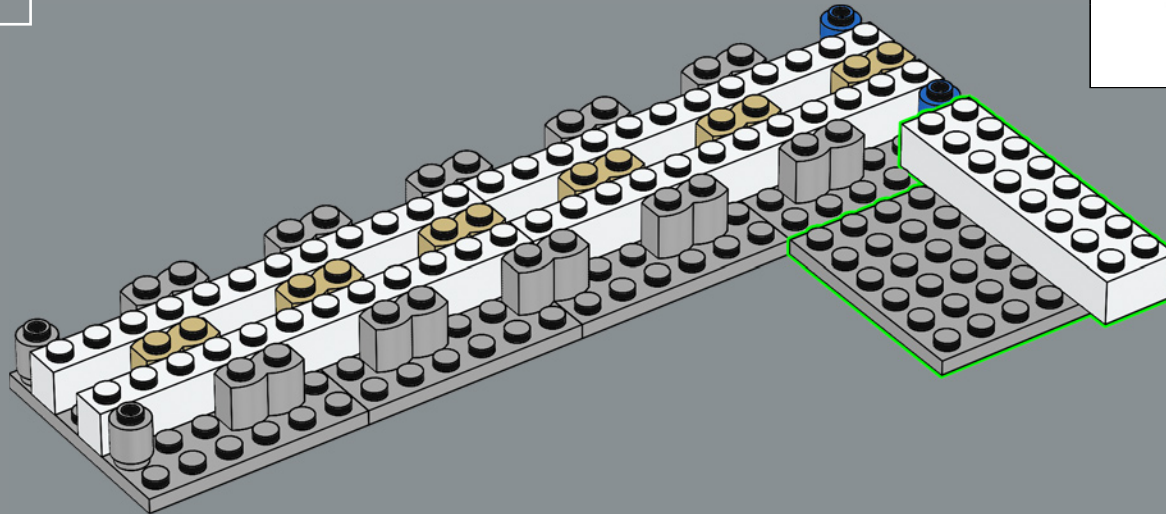

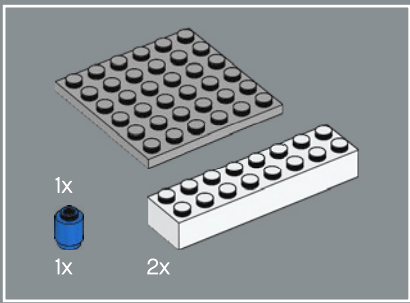

172

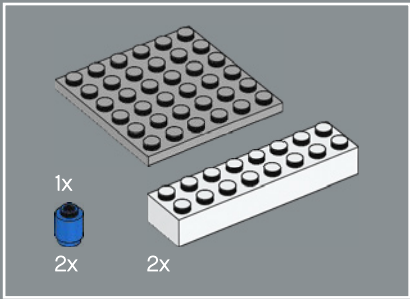
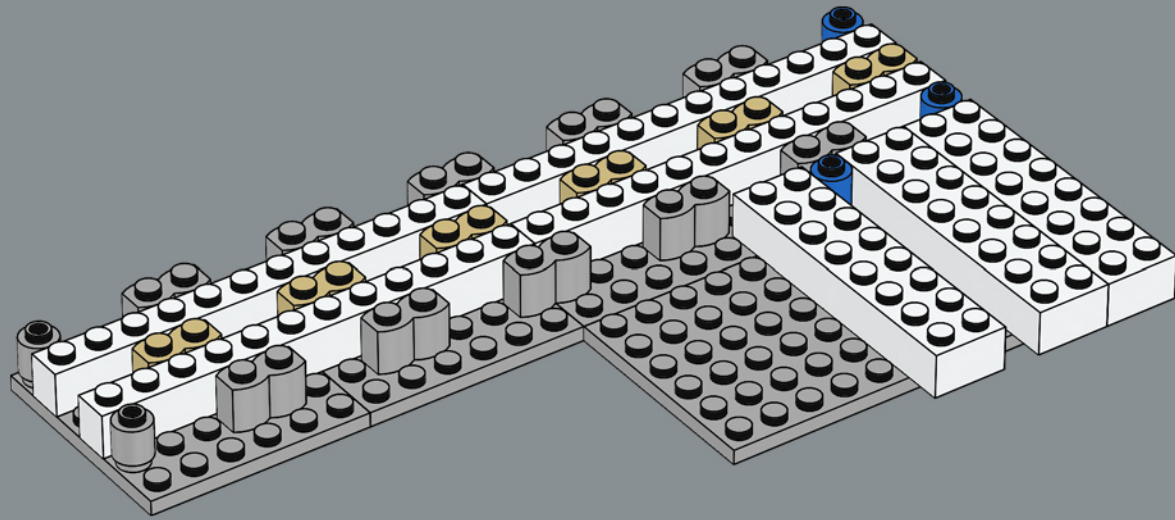

173

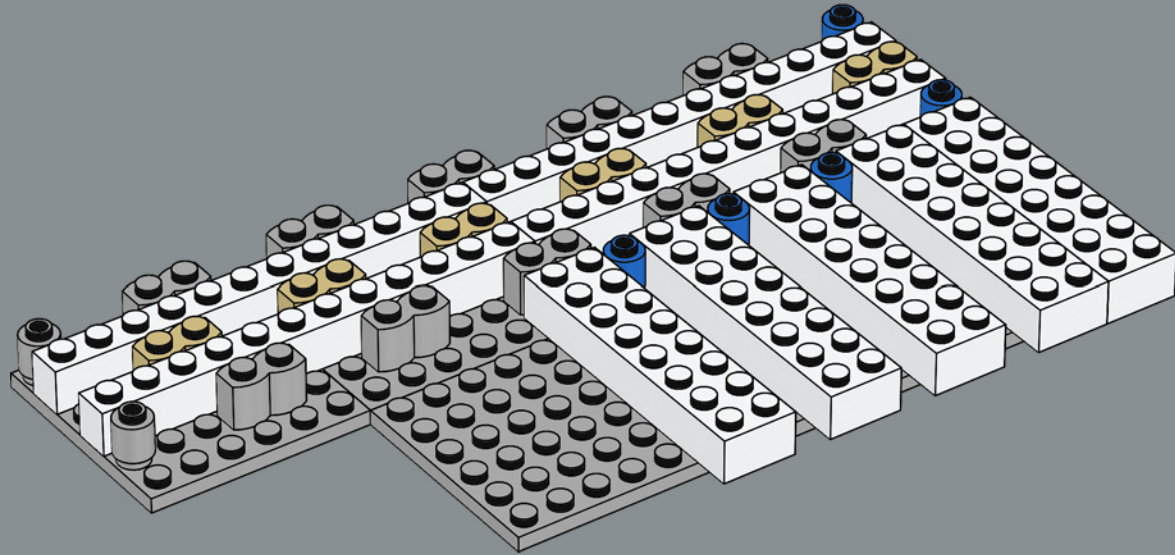



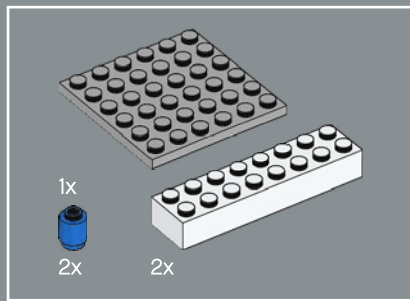

174

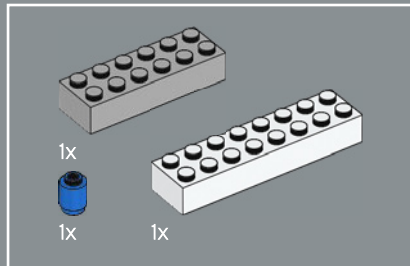
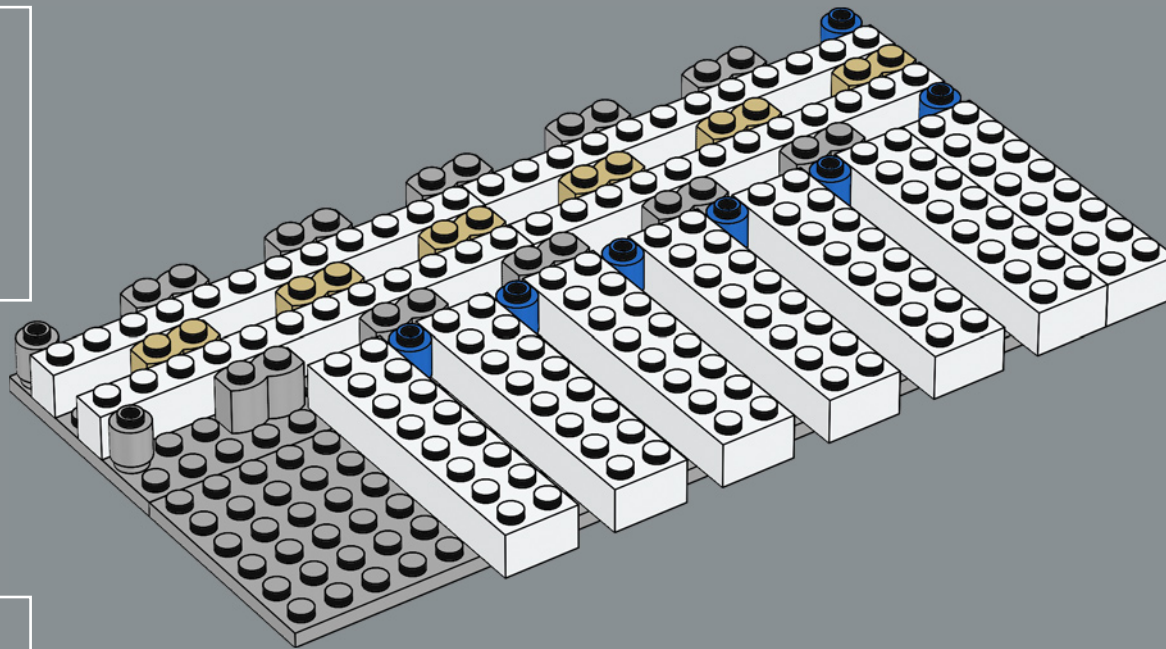

175



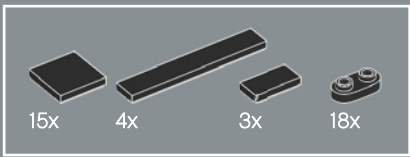

176

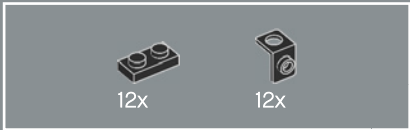
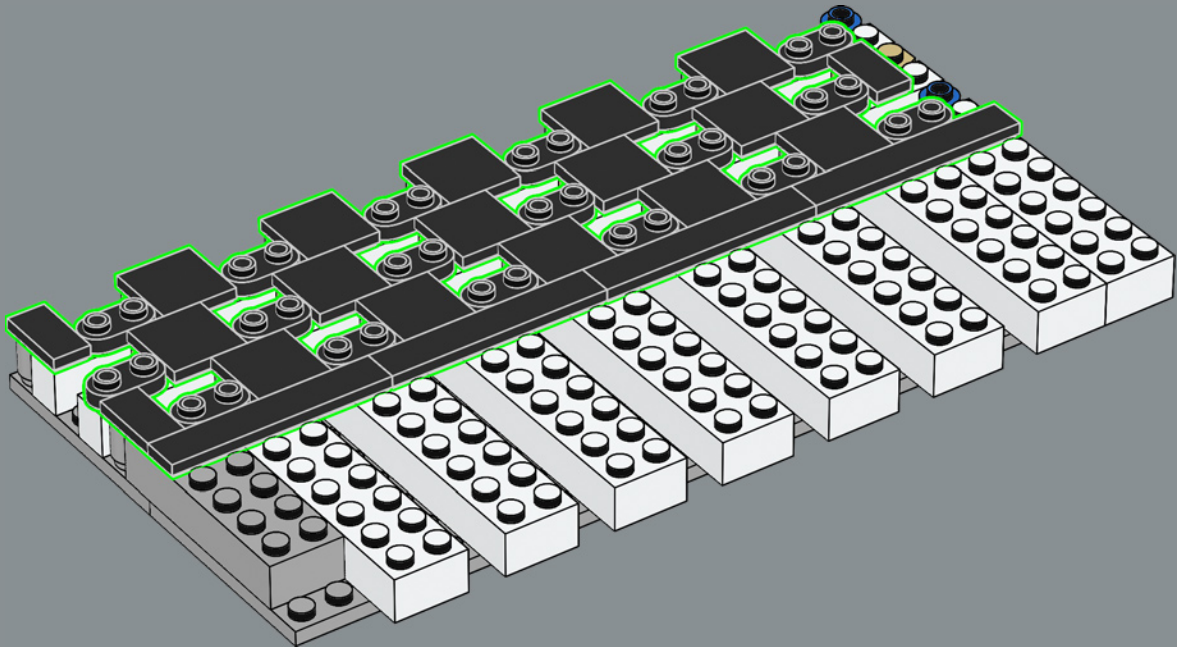

177

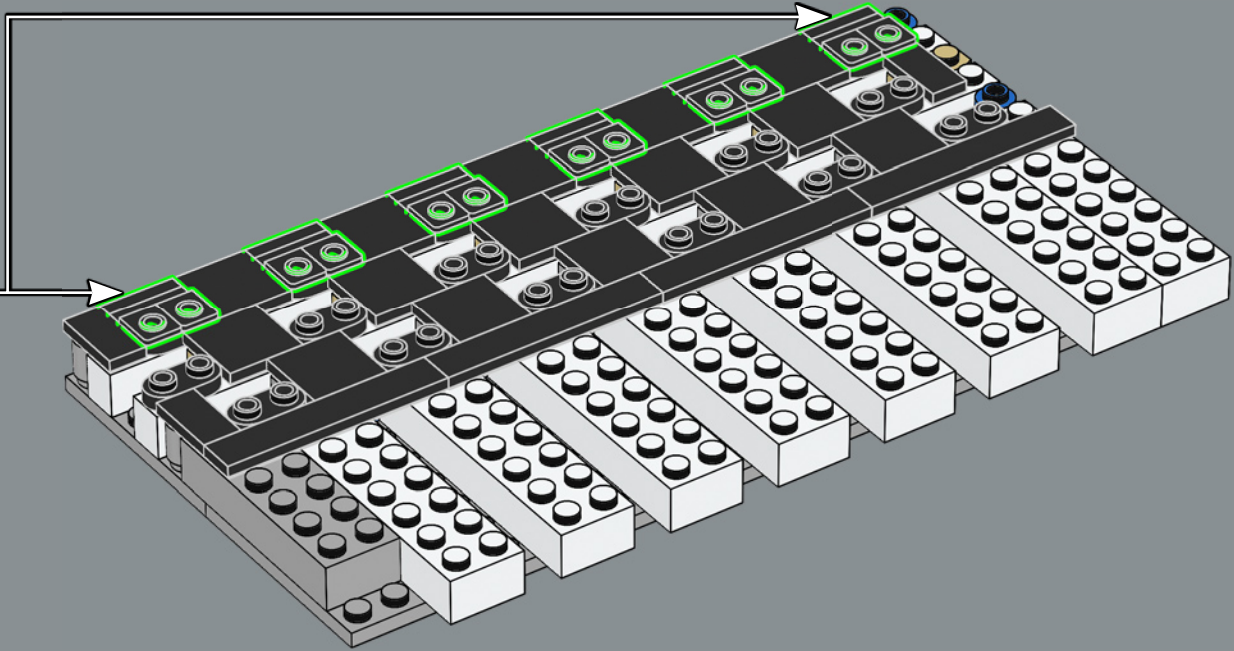
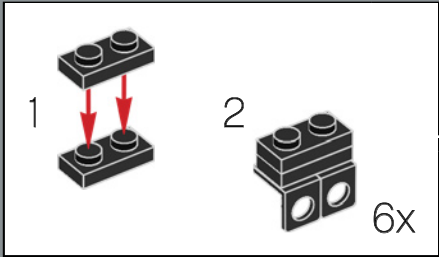

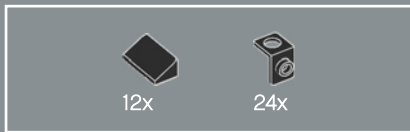

178

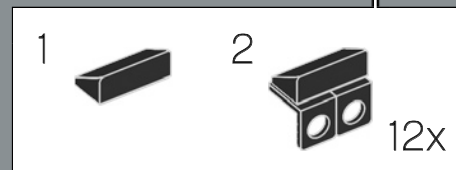
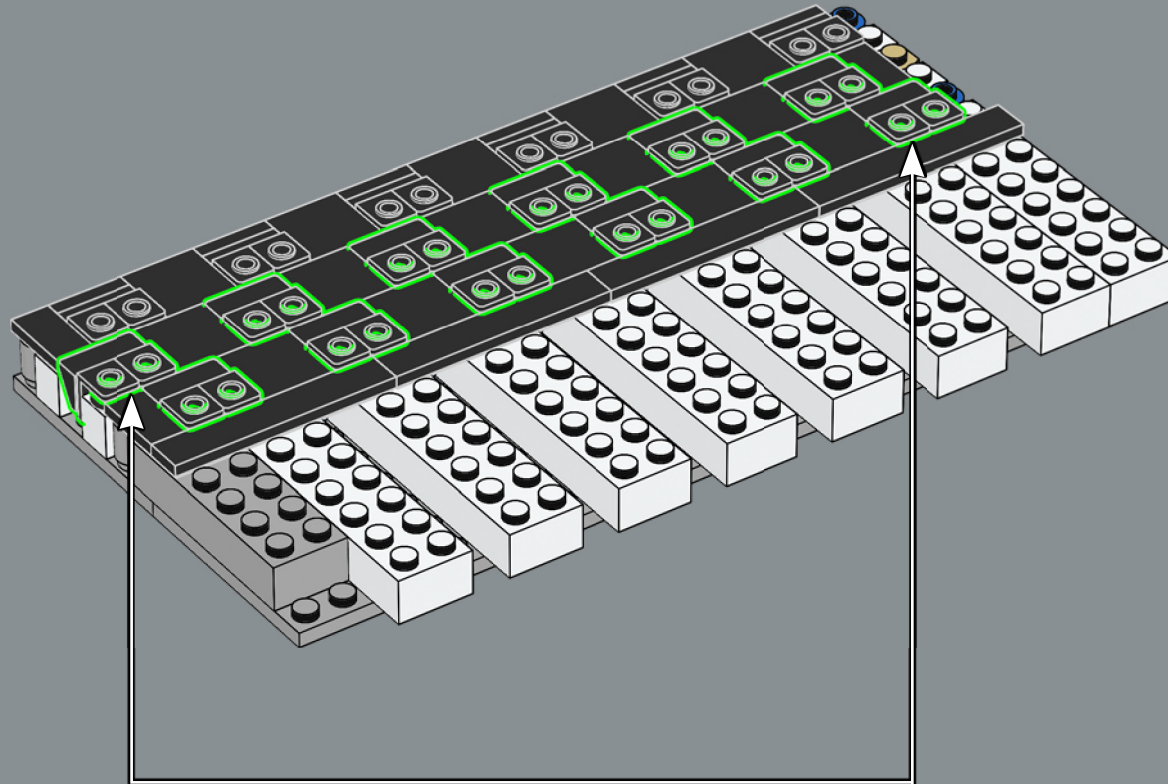

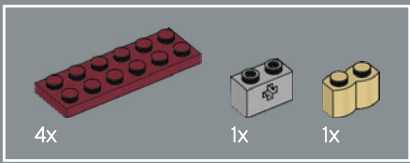

179

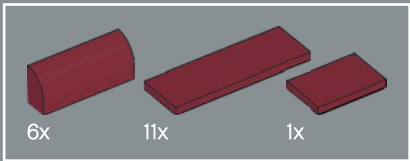
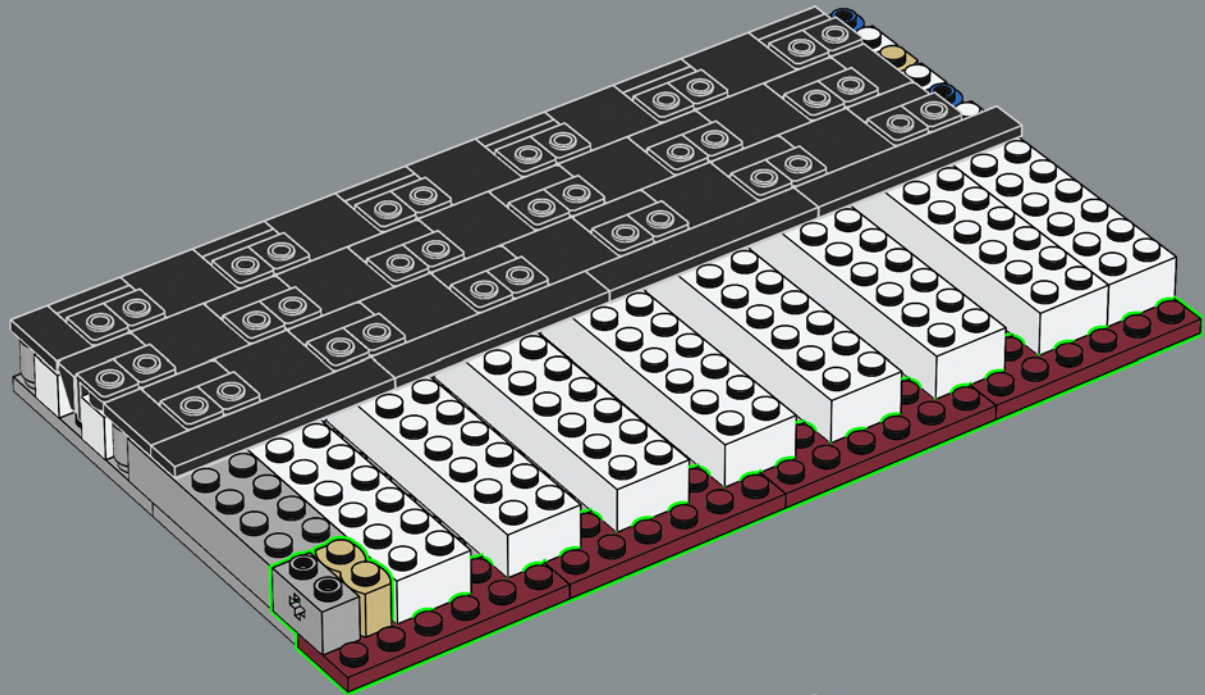

180

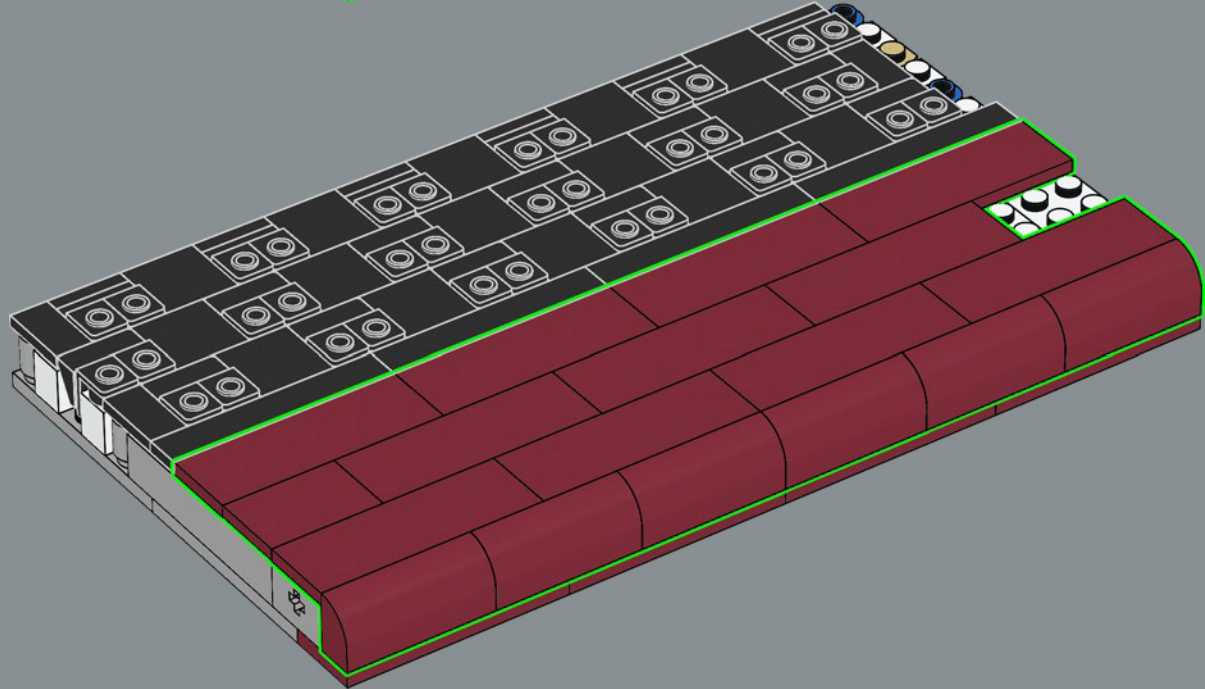

Der Schiffsrumpf wurde von mehr als 3 Millionen Eisen- und Stahlclips zusammengehalten, die über 1.200 Tonnen wogen.

181

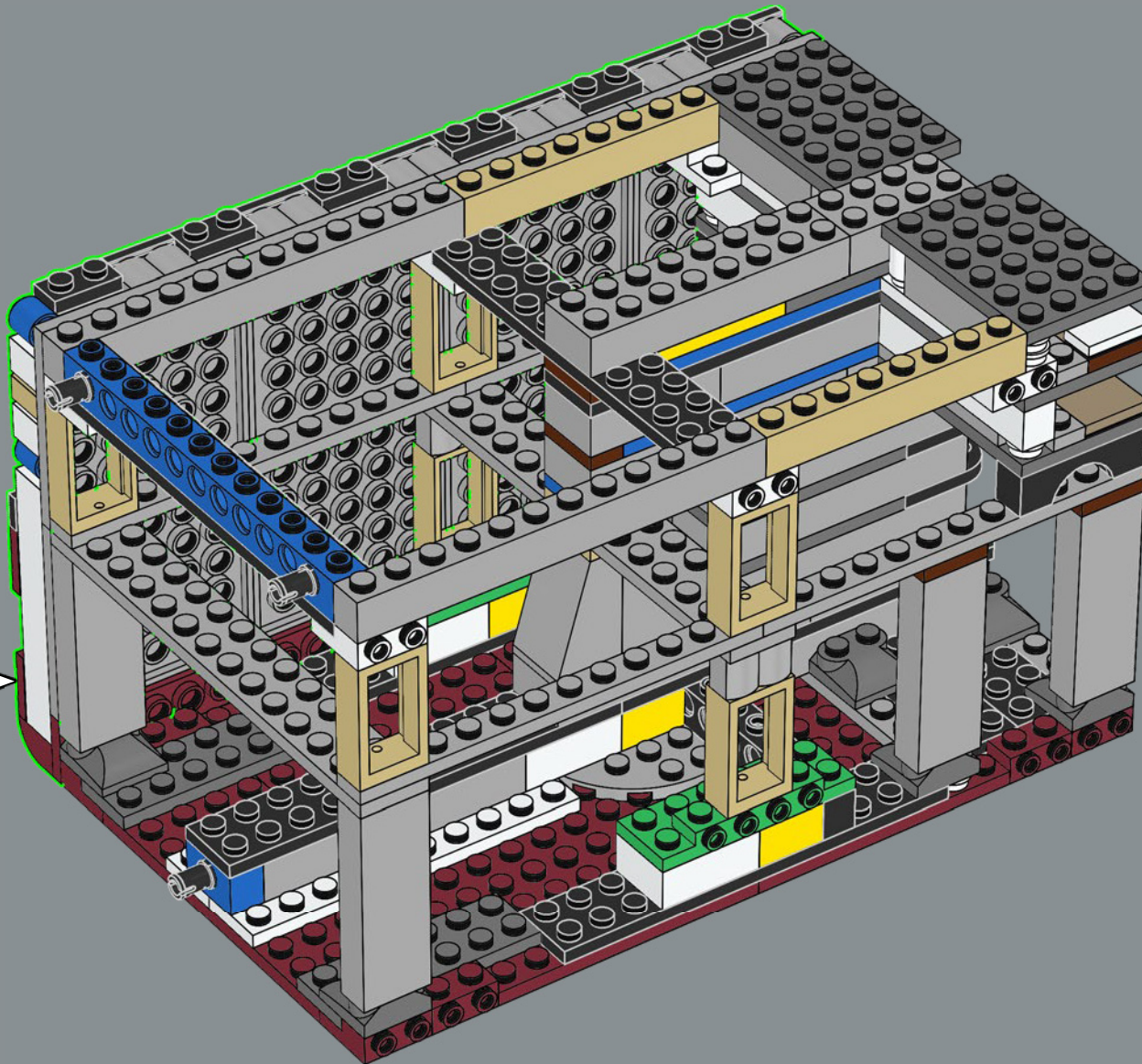

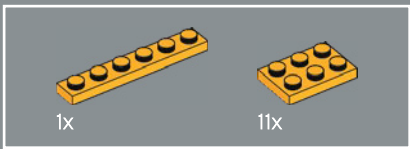

182

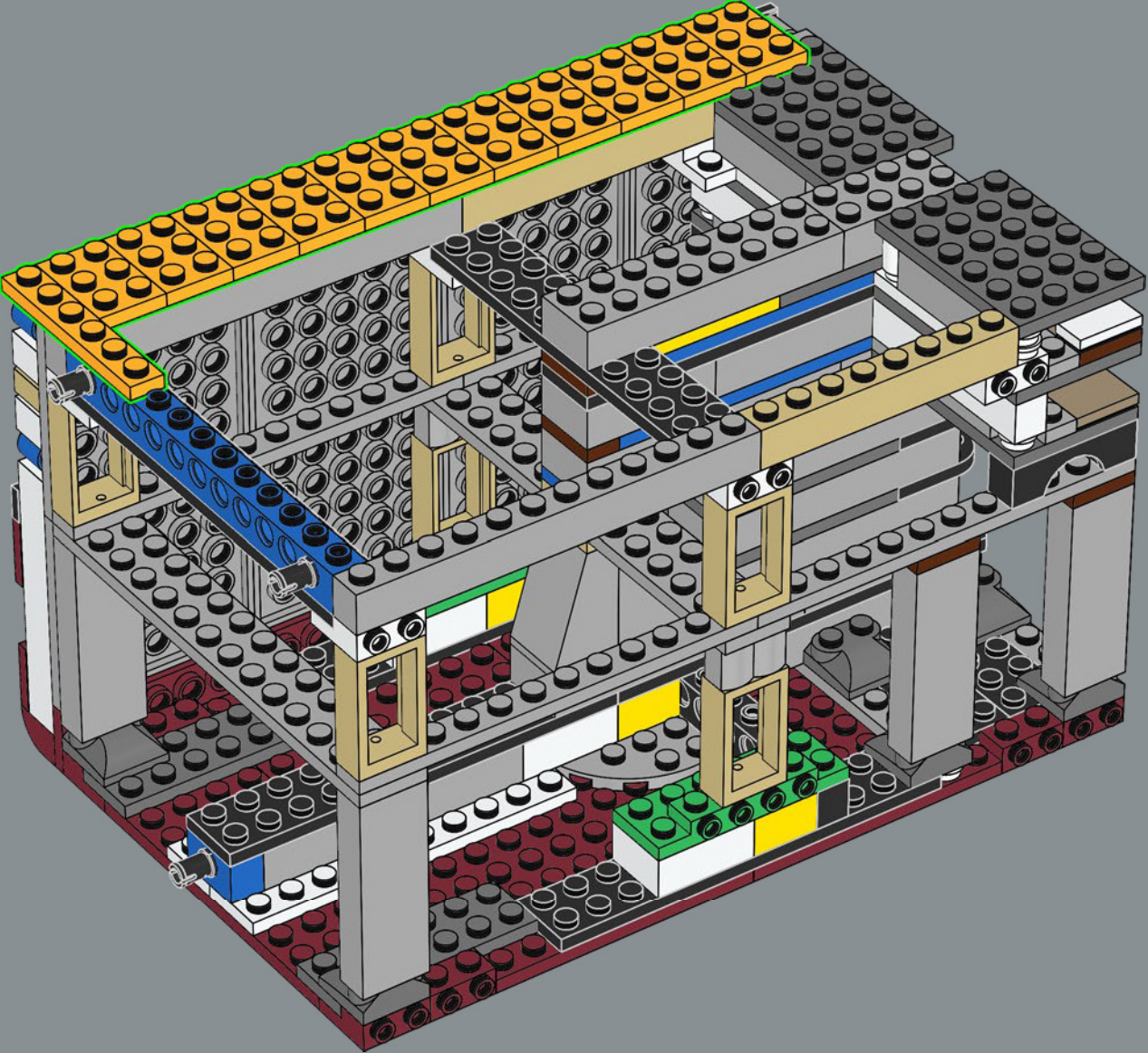

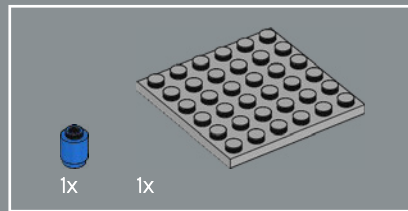
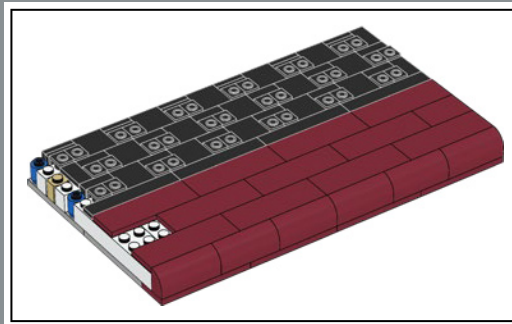
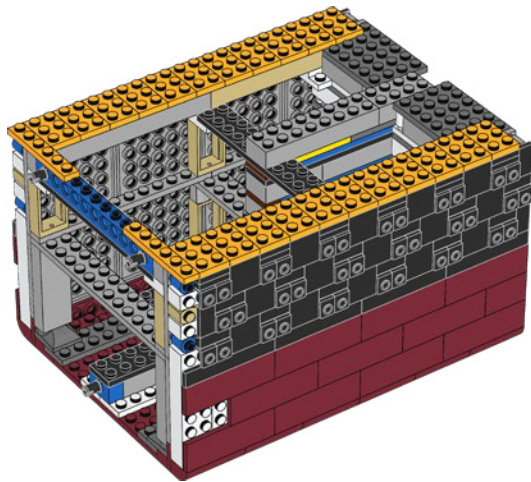
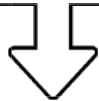

183

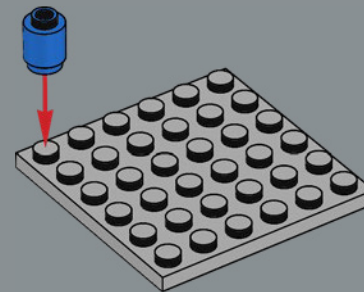

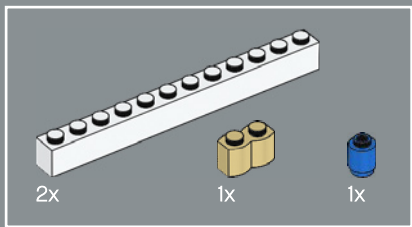

184

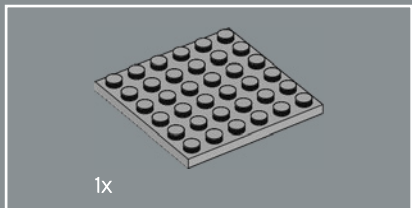
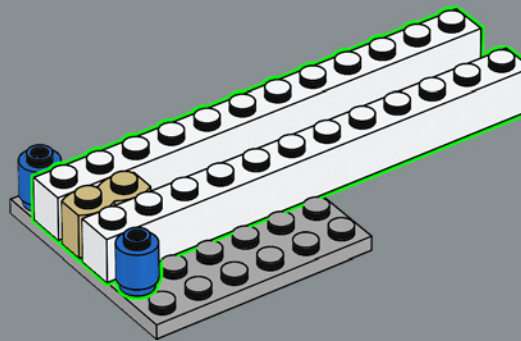

185

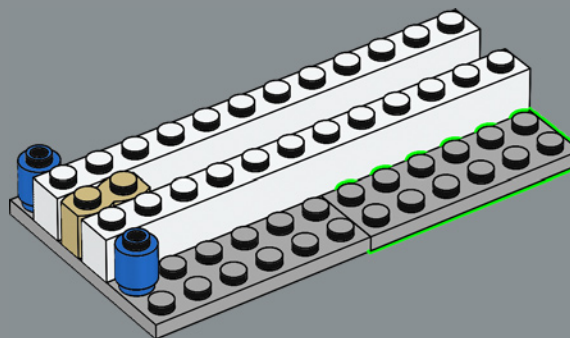



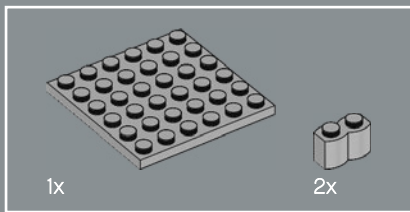

186

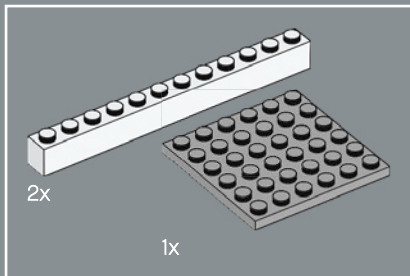
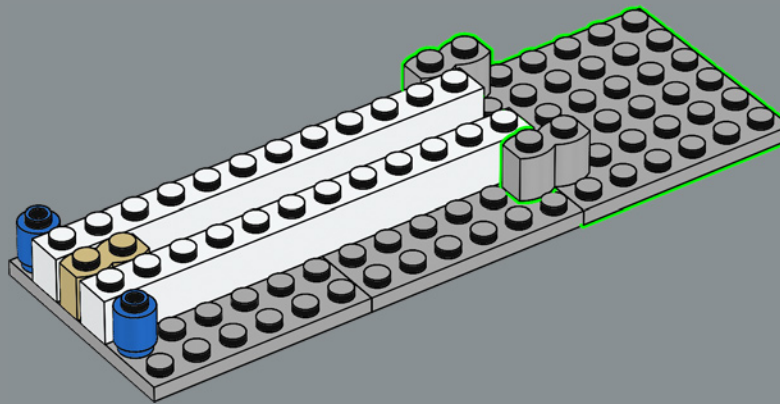

187

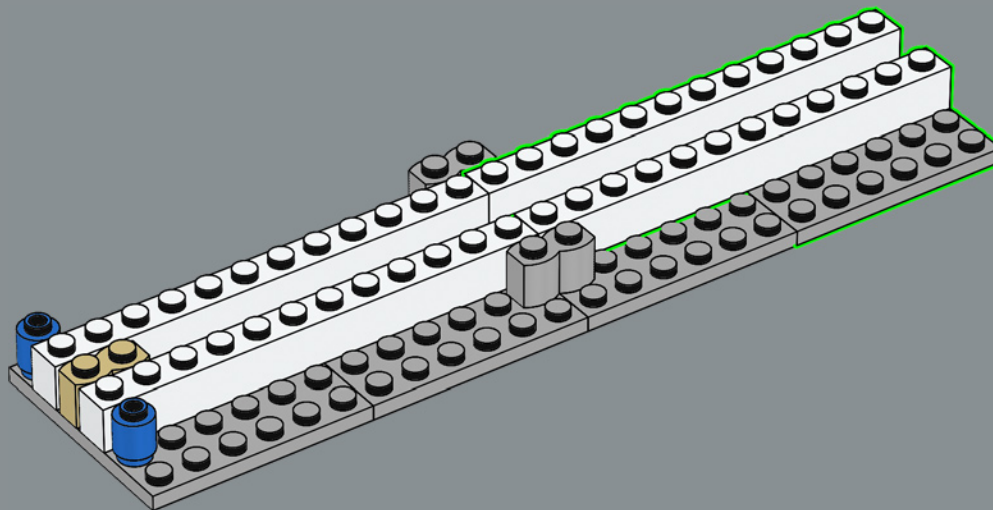



188

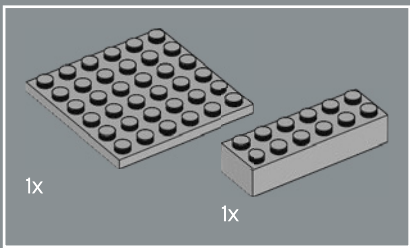
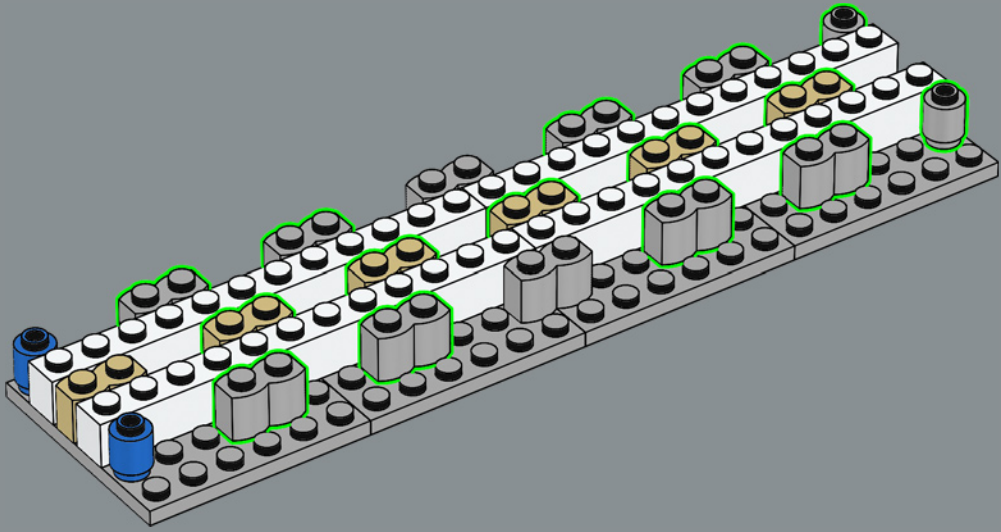

189

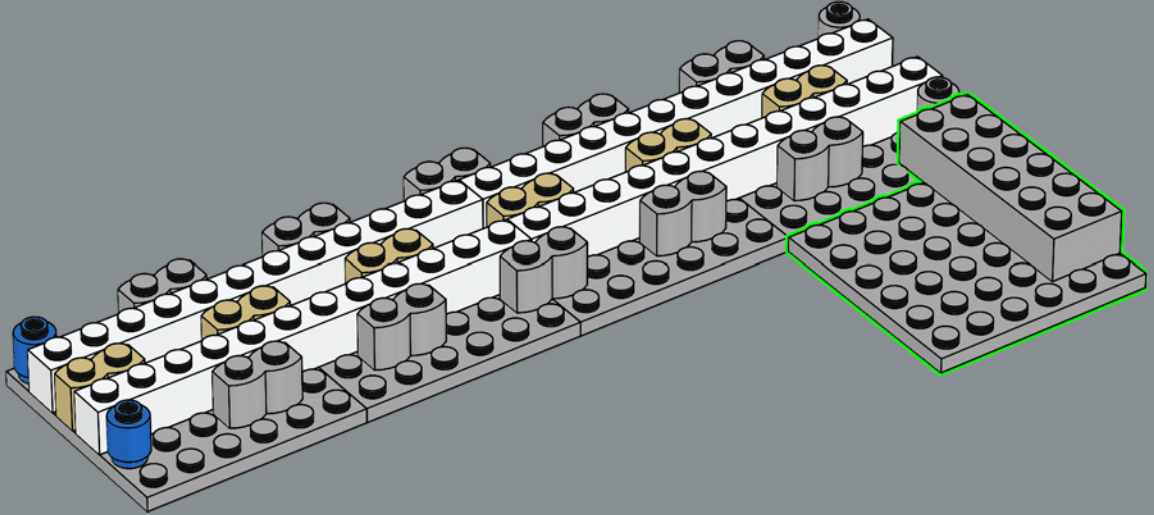

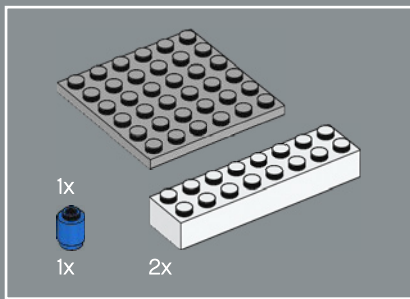

190

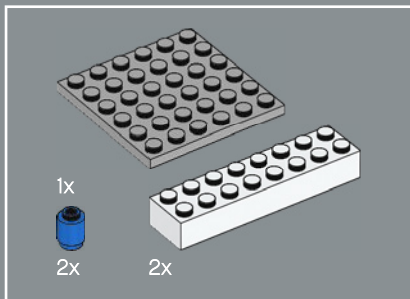
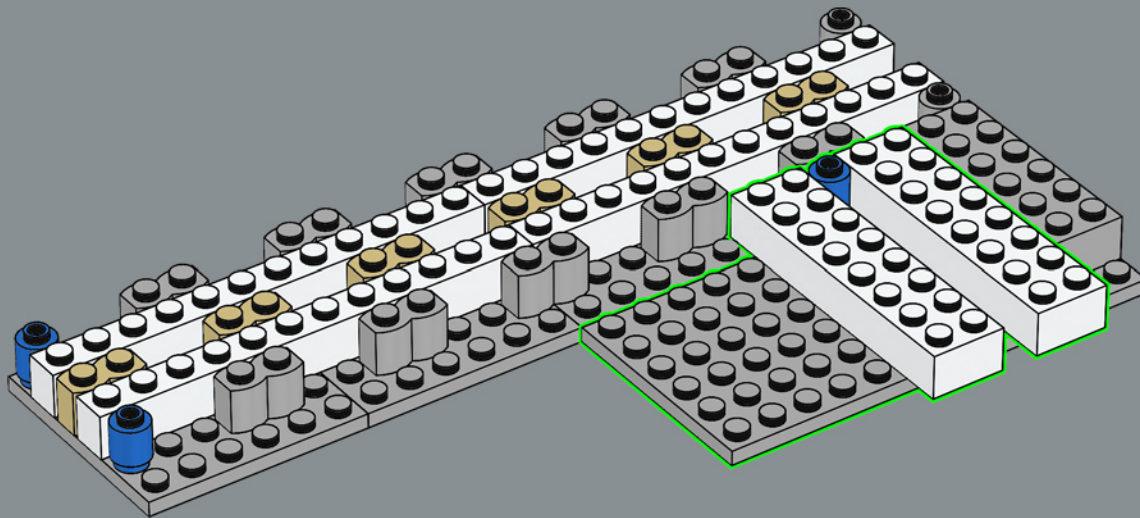

191

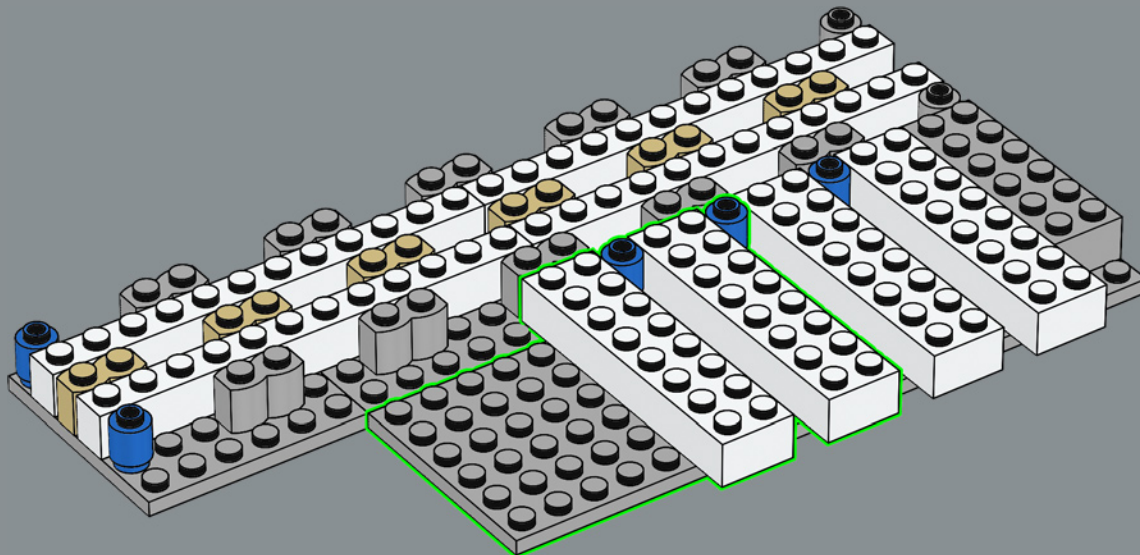

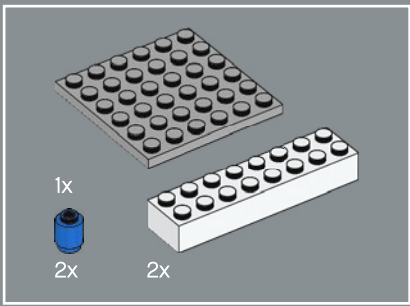

192

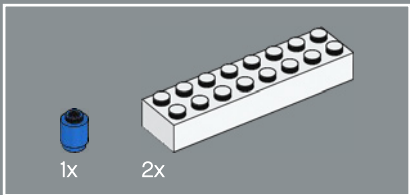
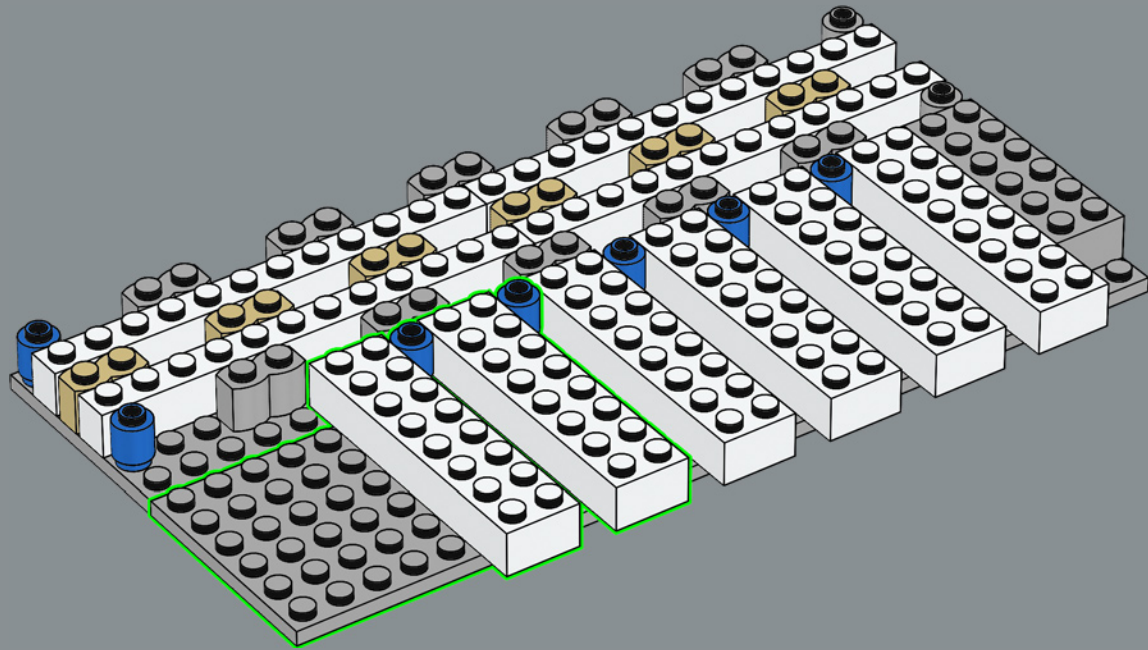

193

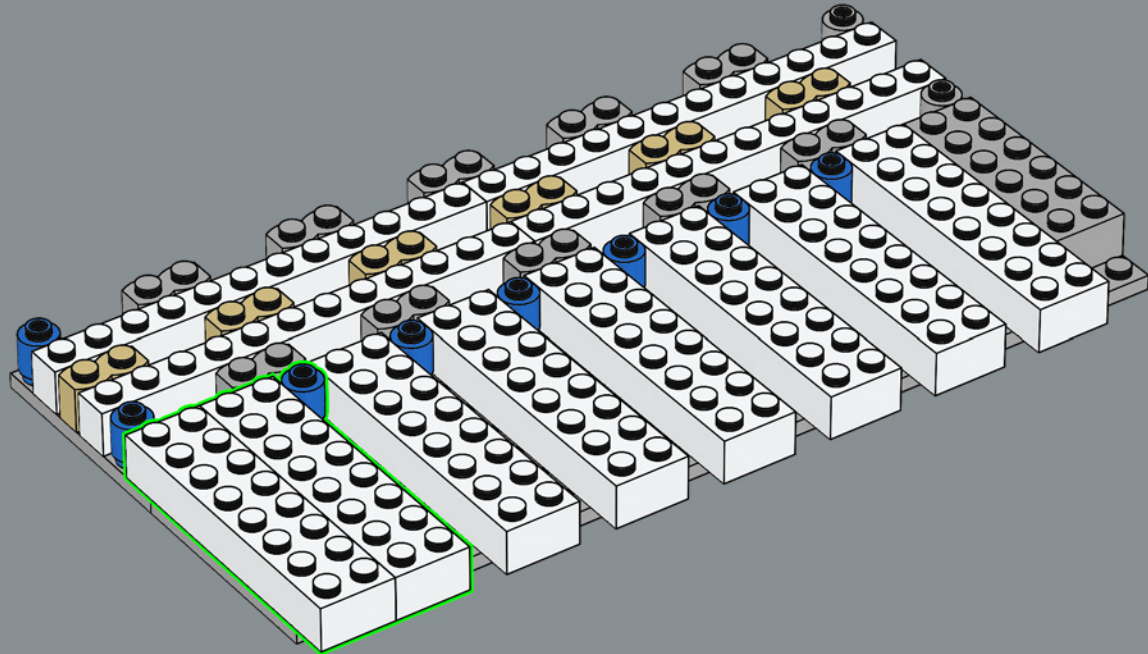

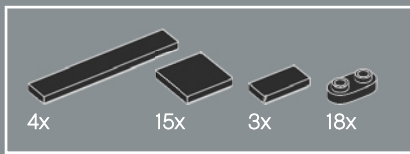

194

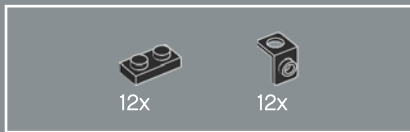
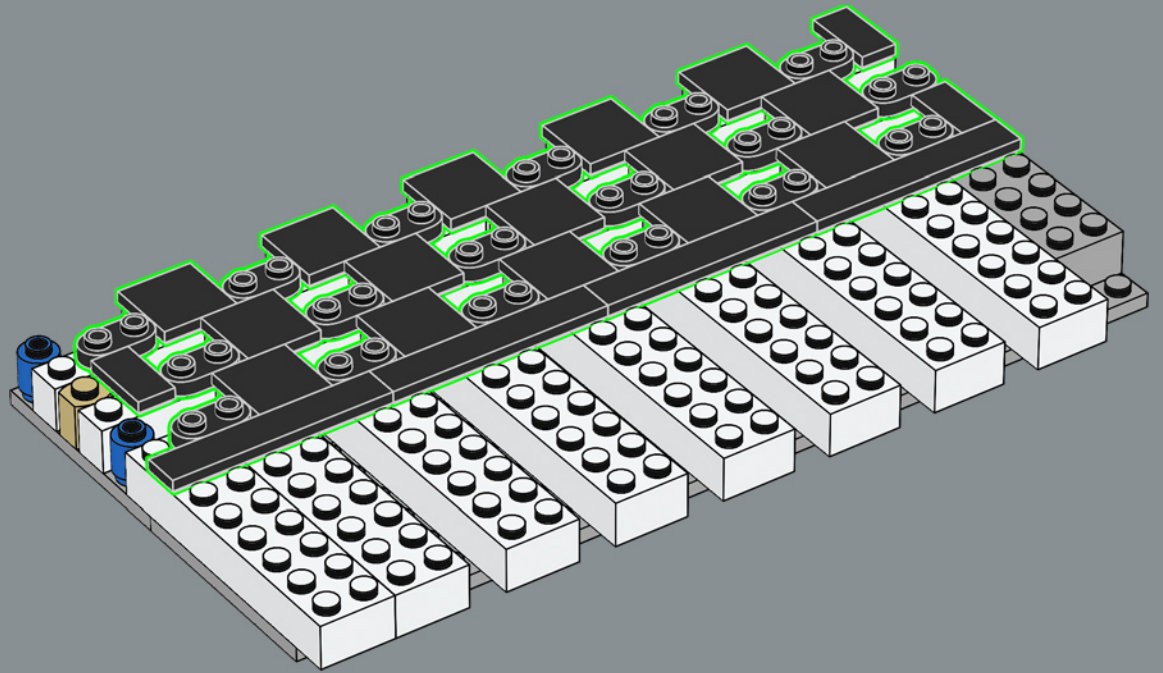

195

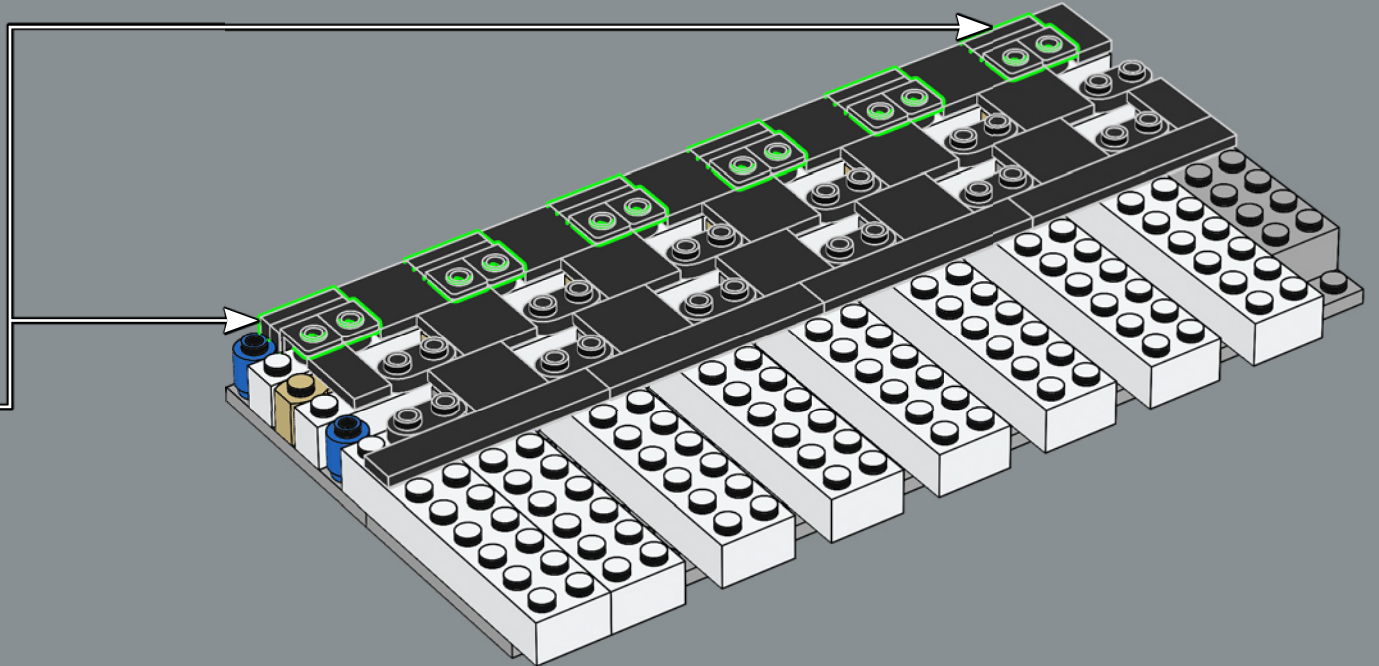
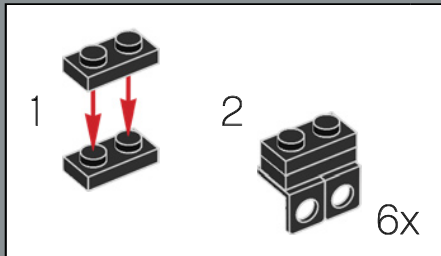

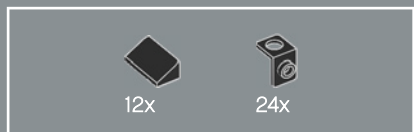

196

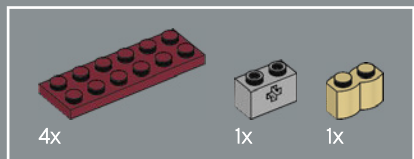
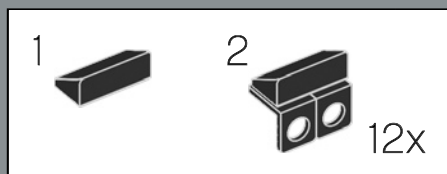
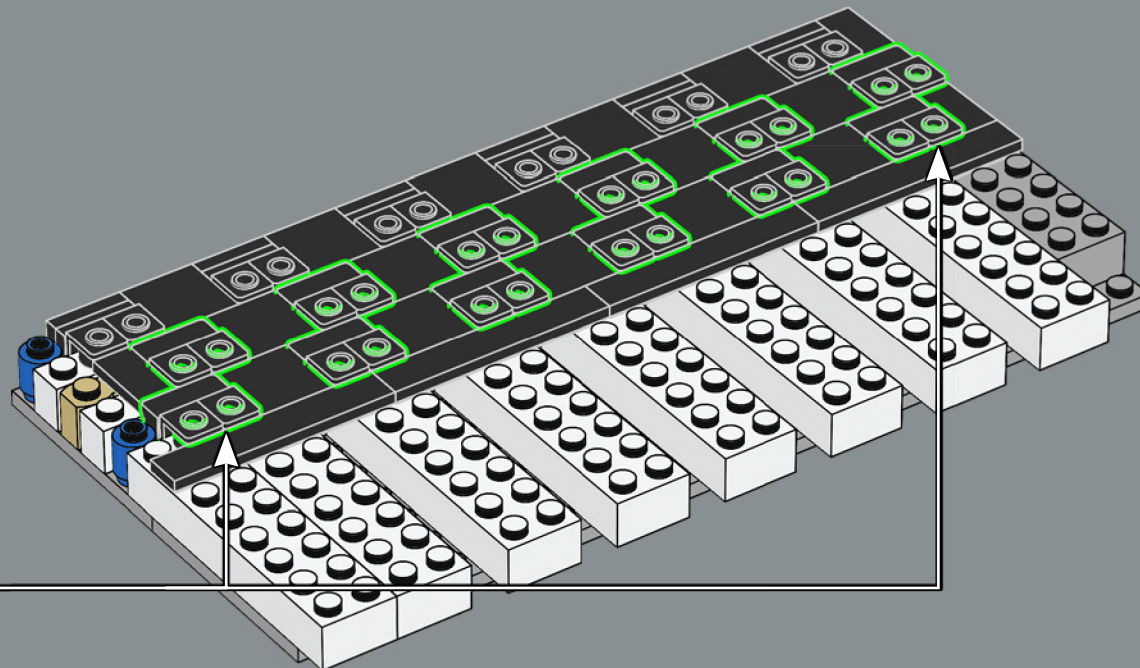

197

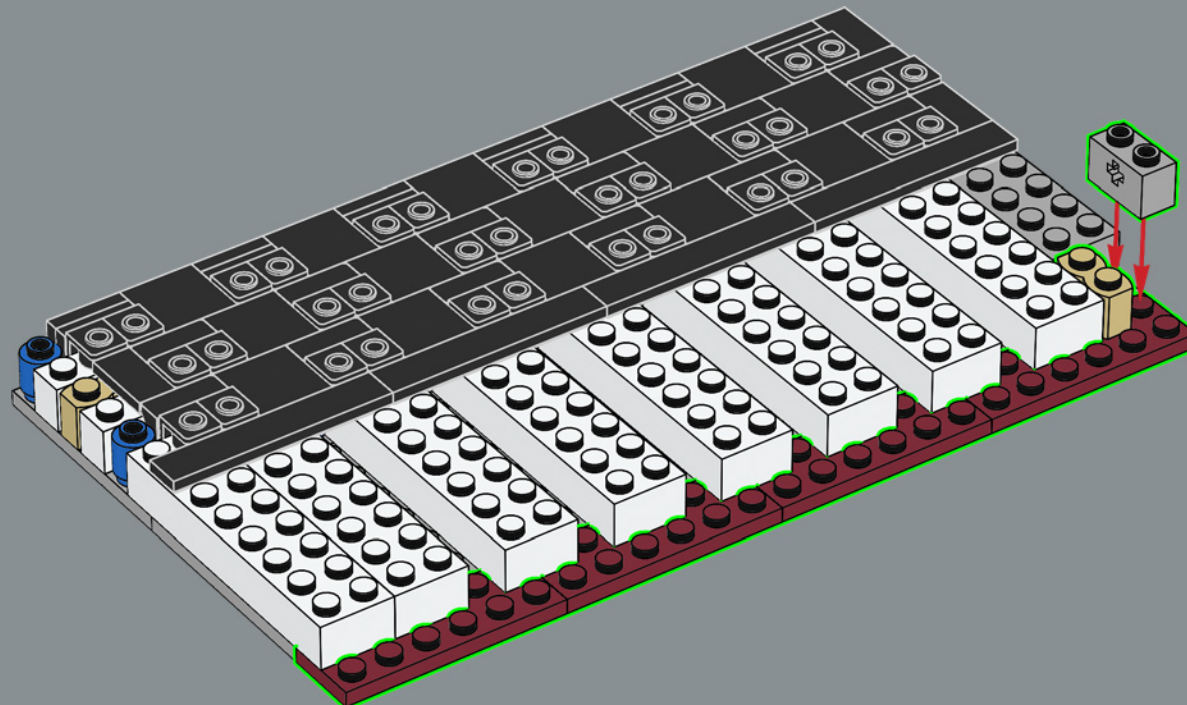

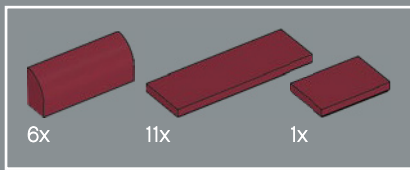

198

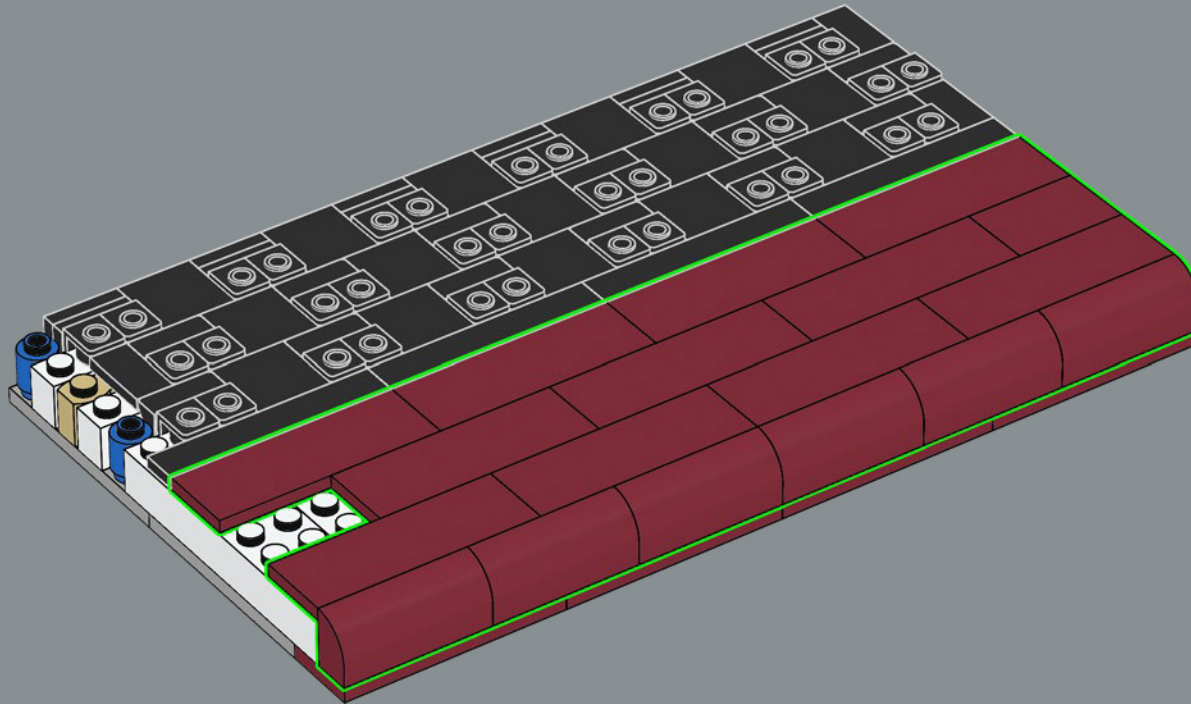

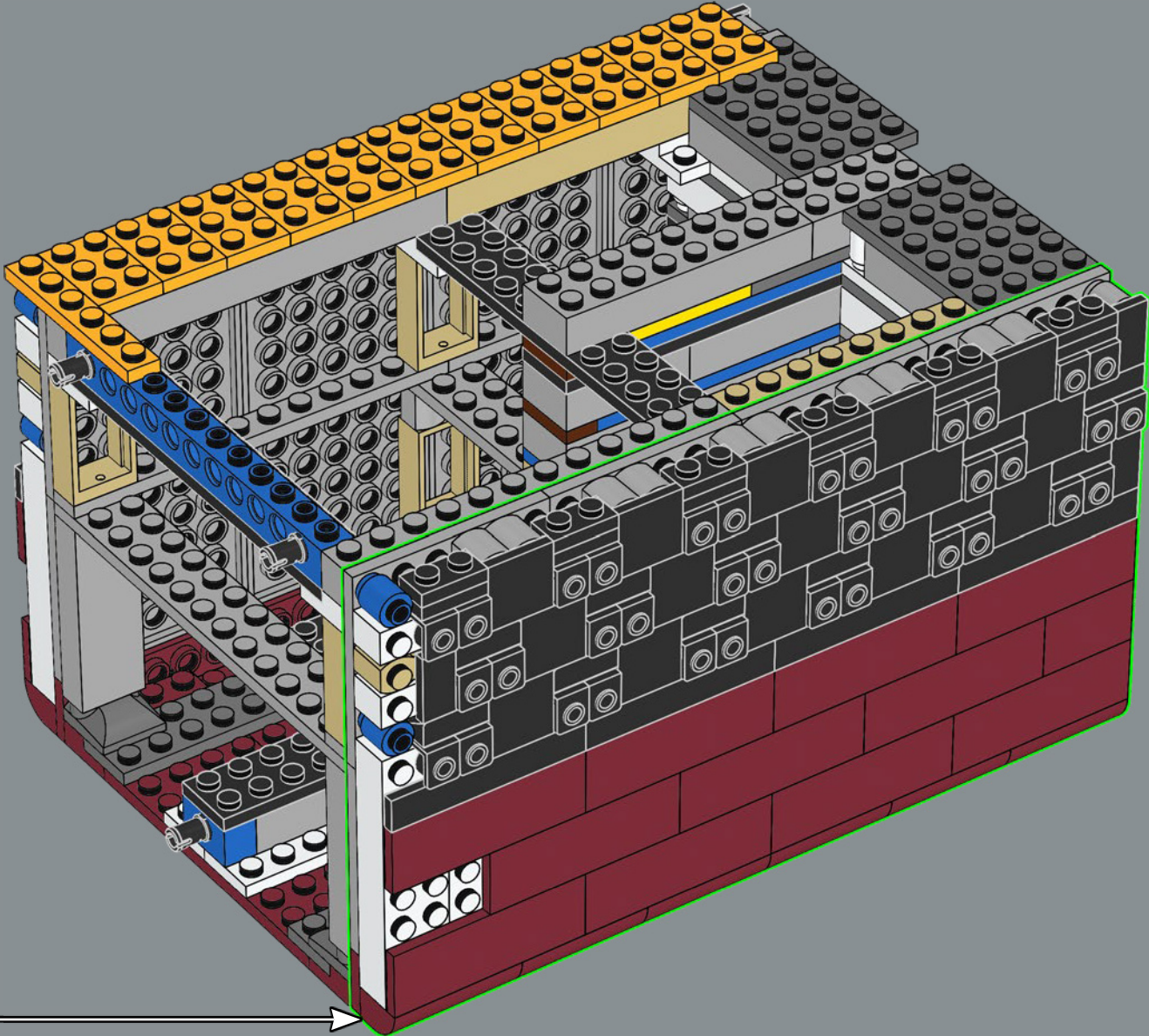



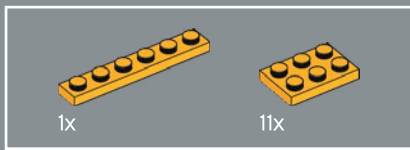

200

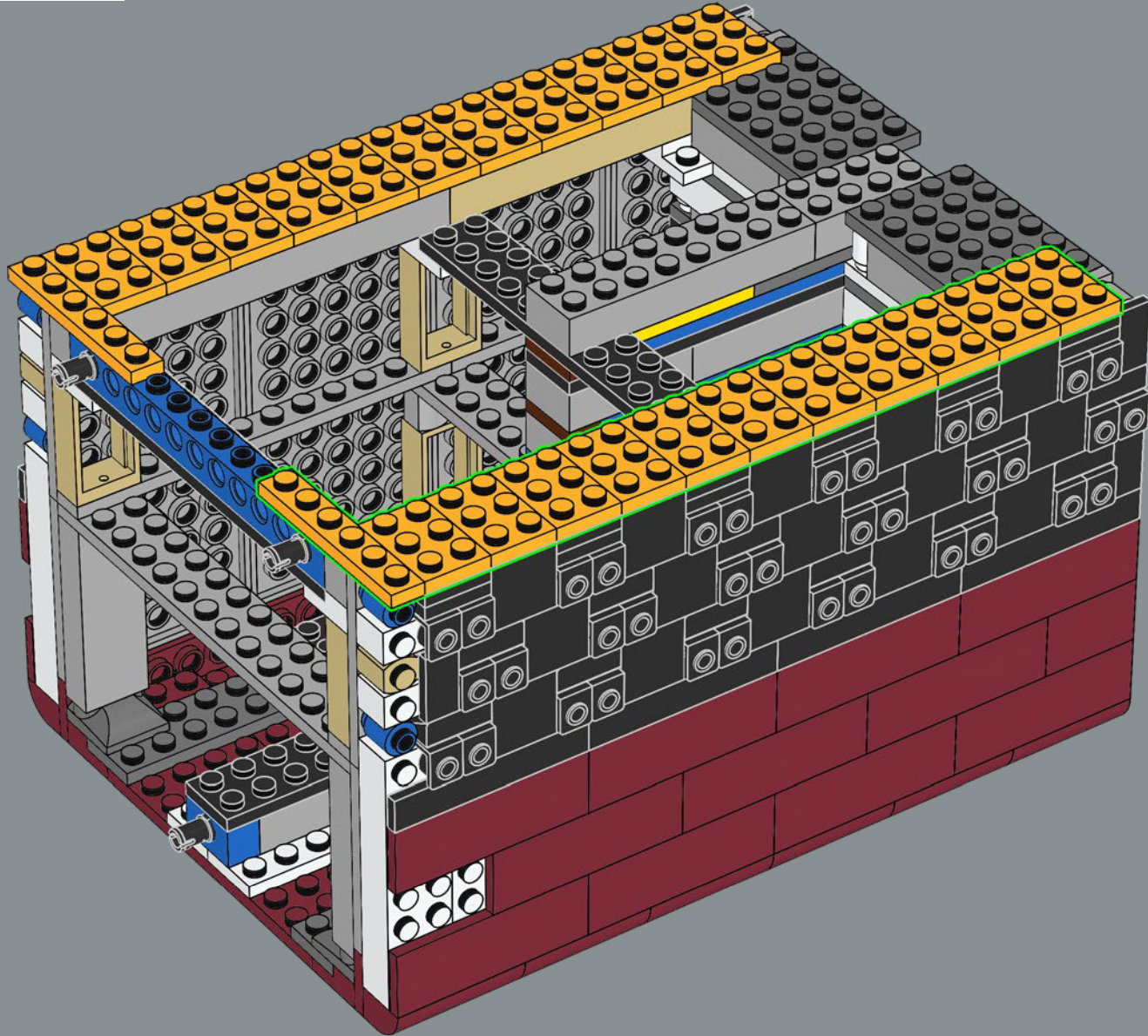

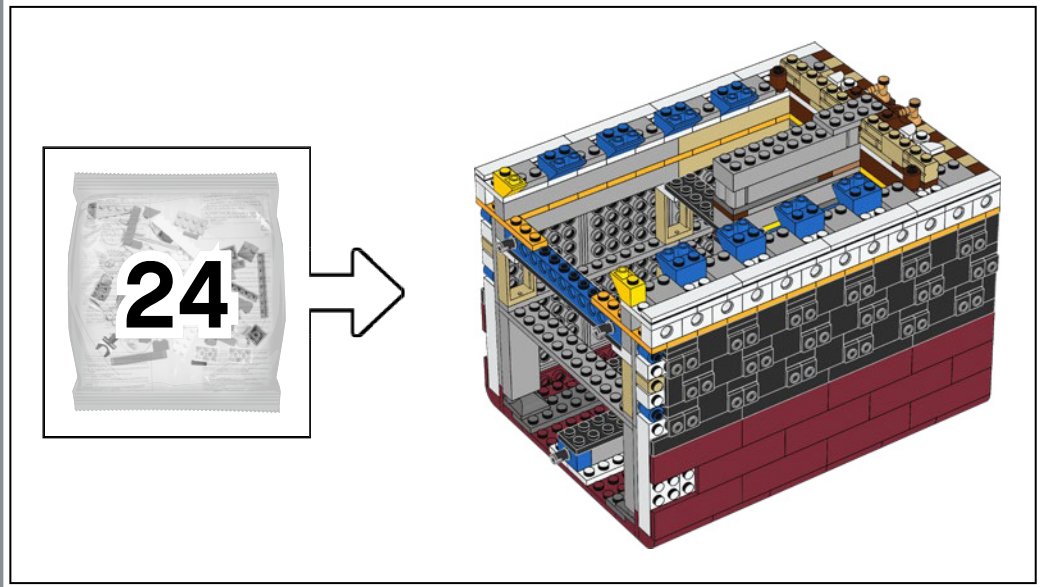

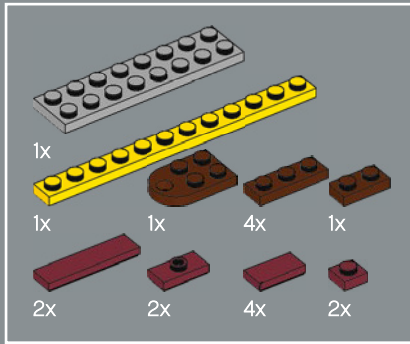

201

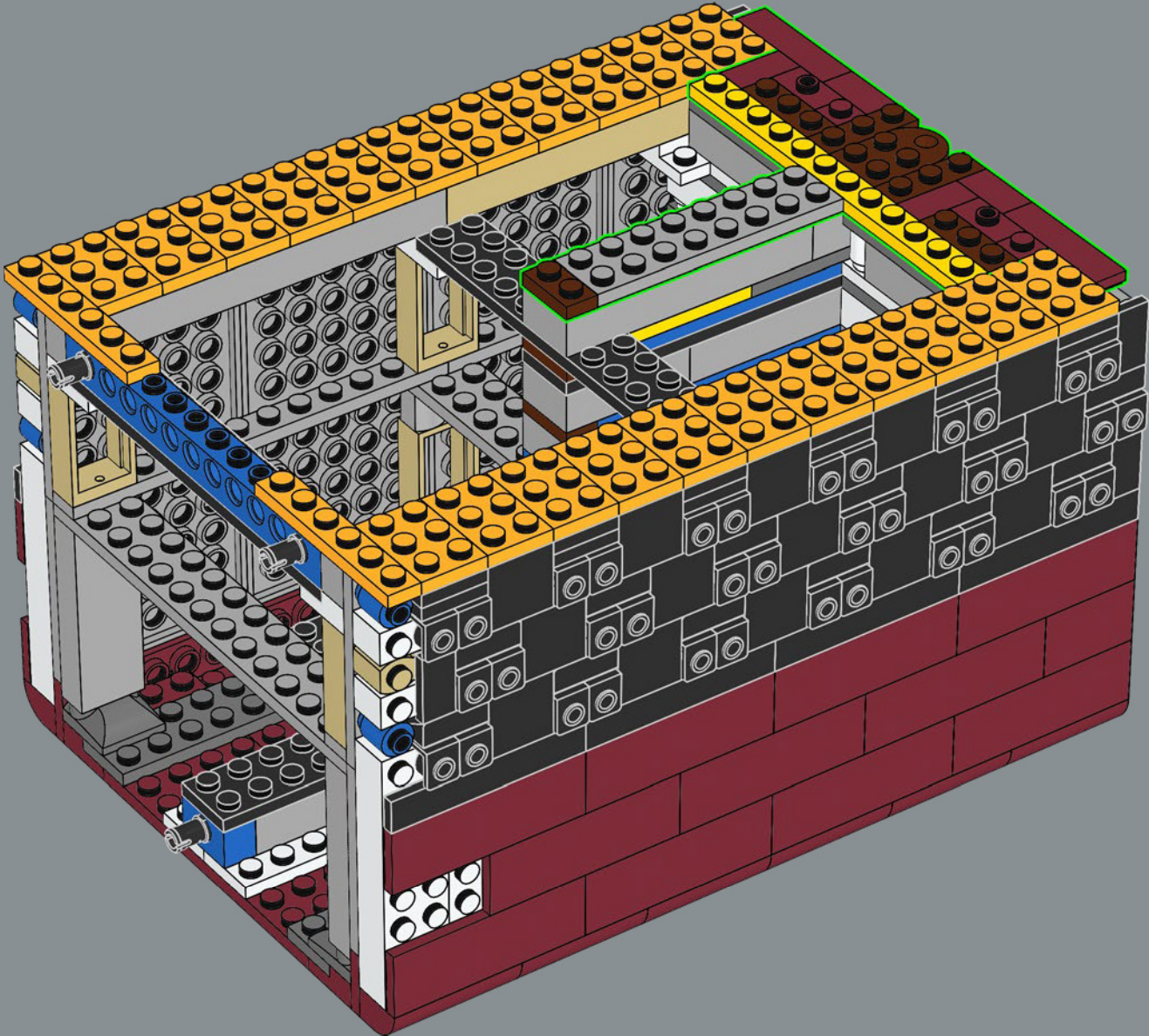

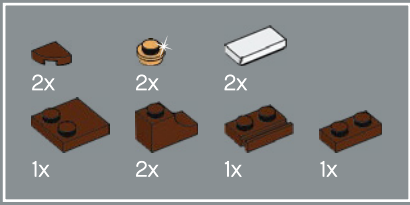

202

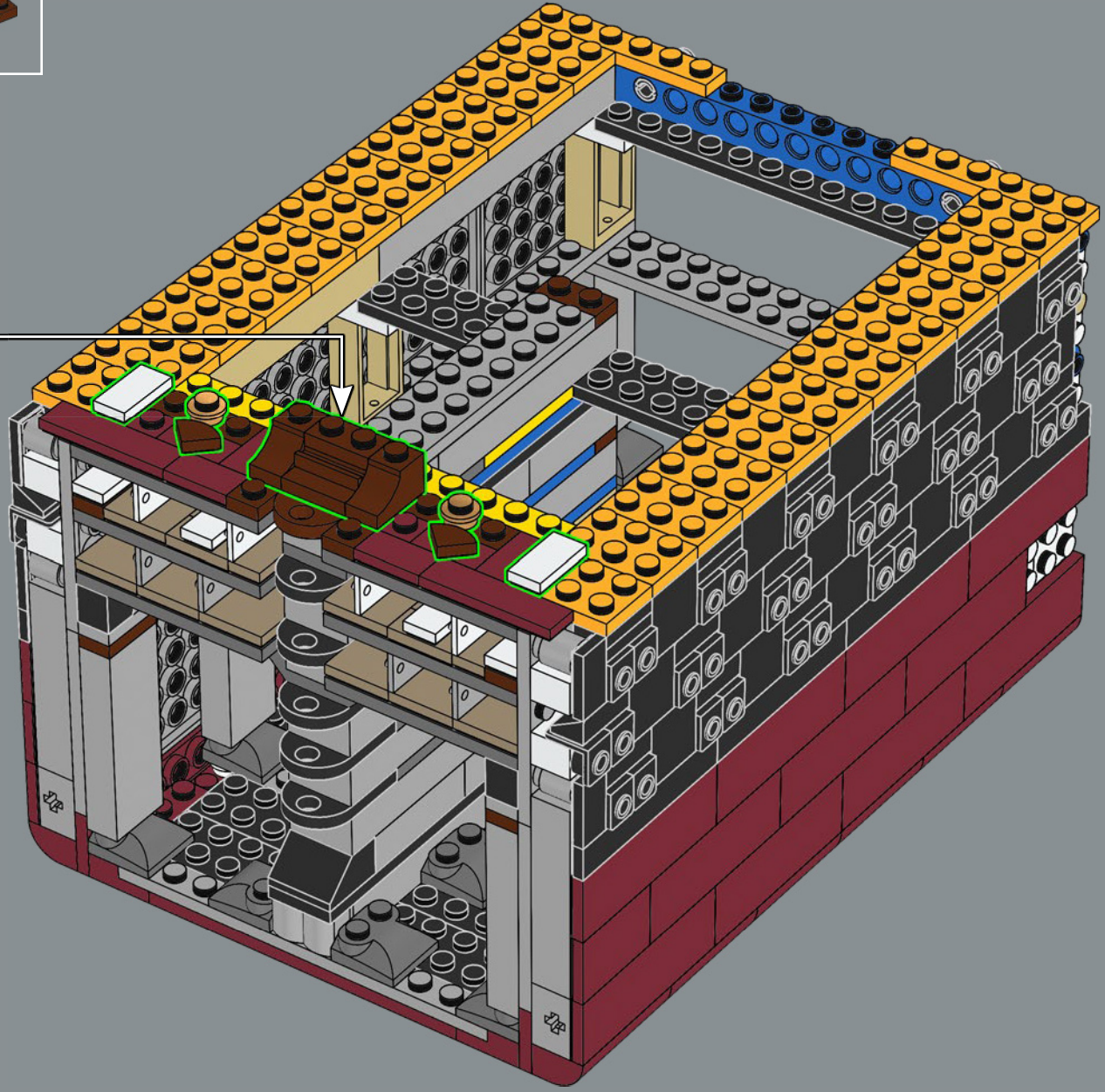
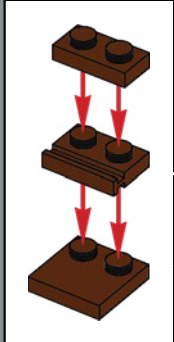

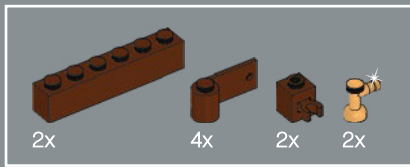

203

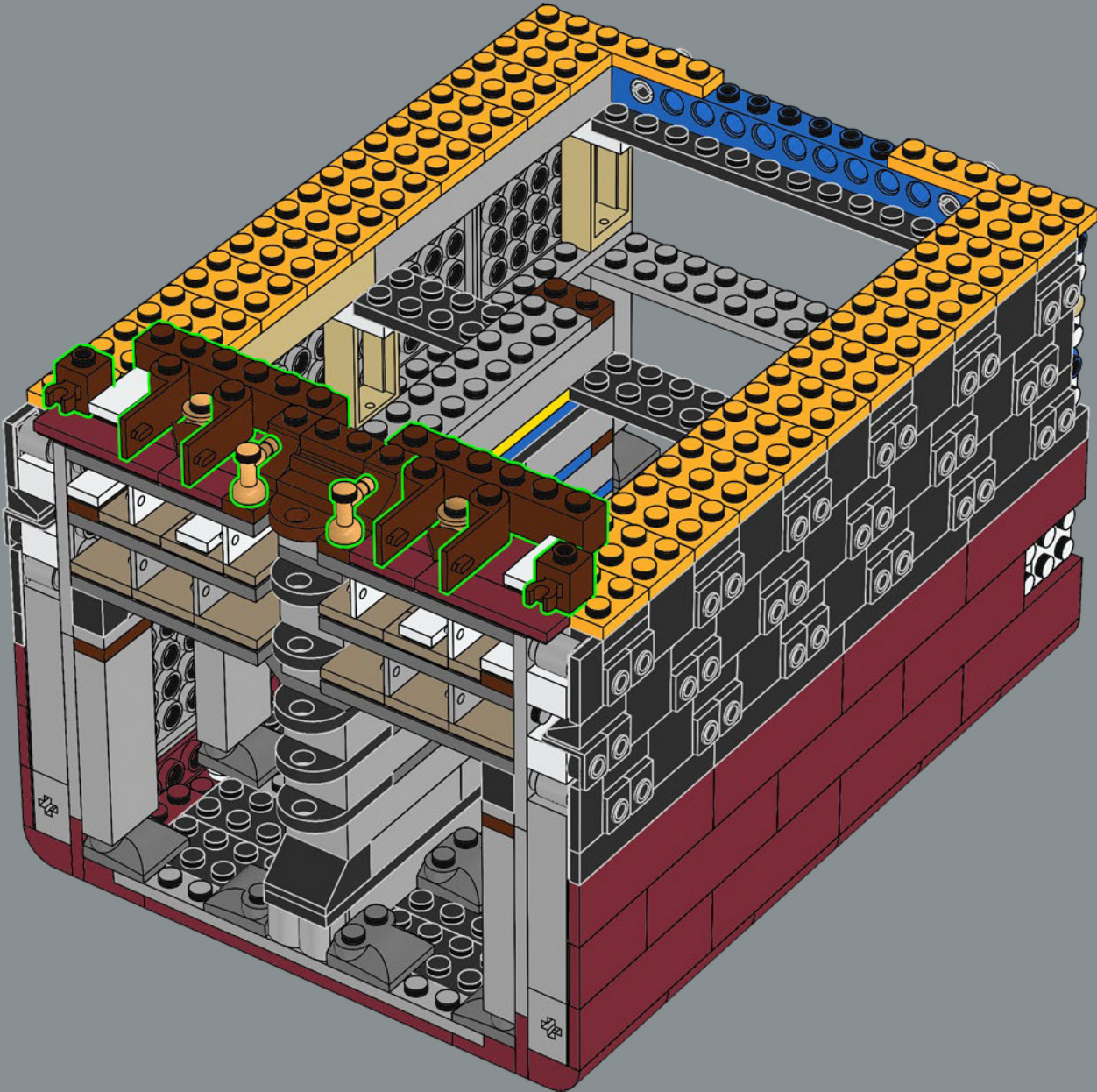

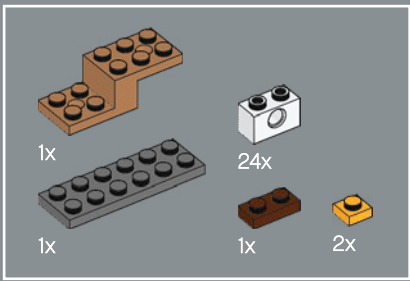

204

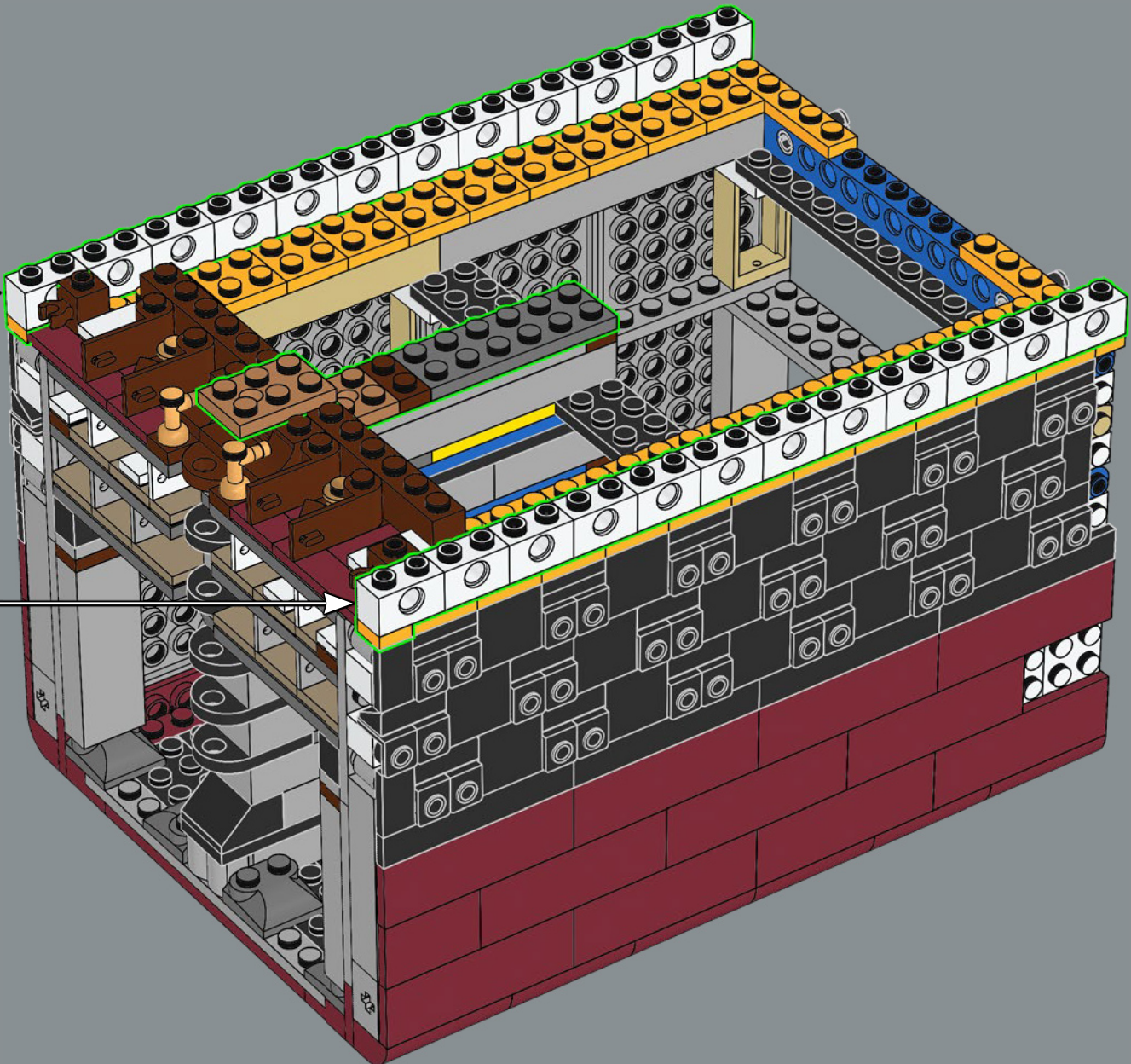
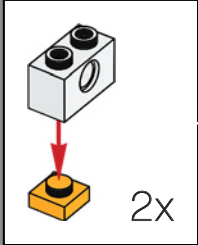

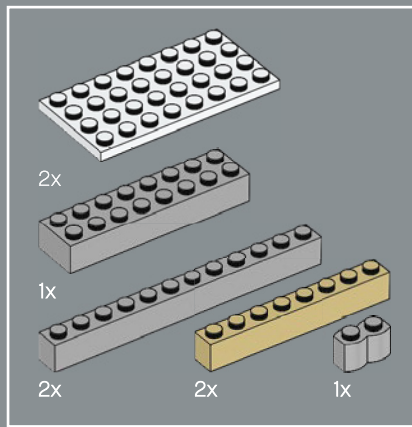

205

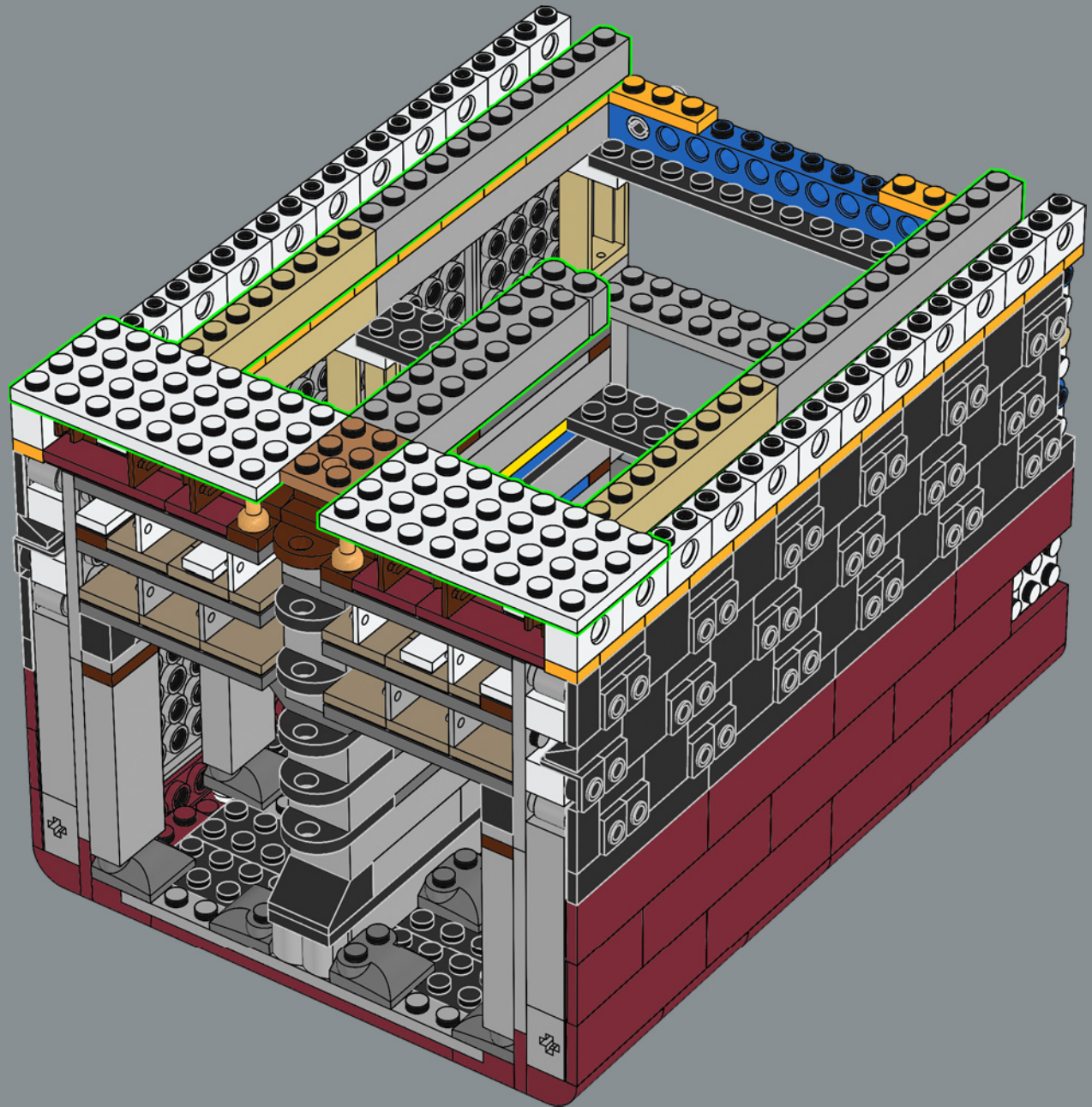

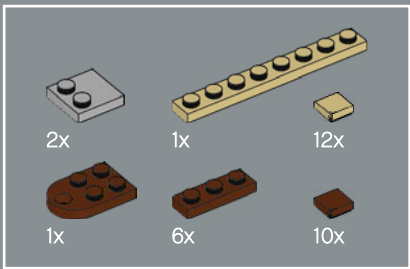

206

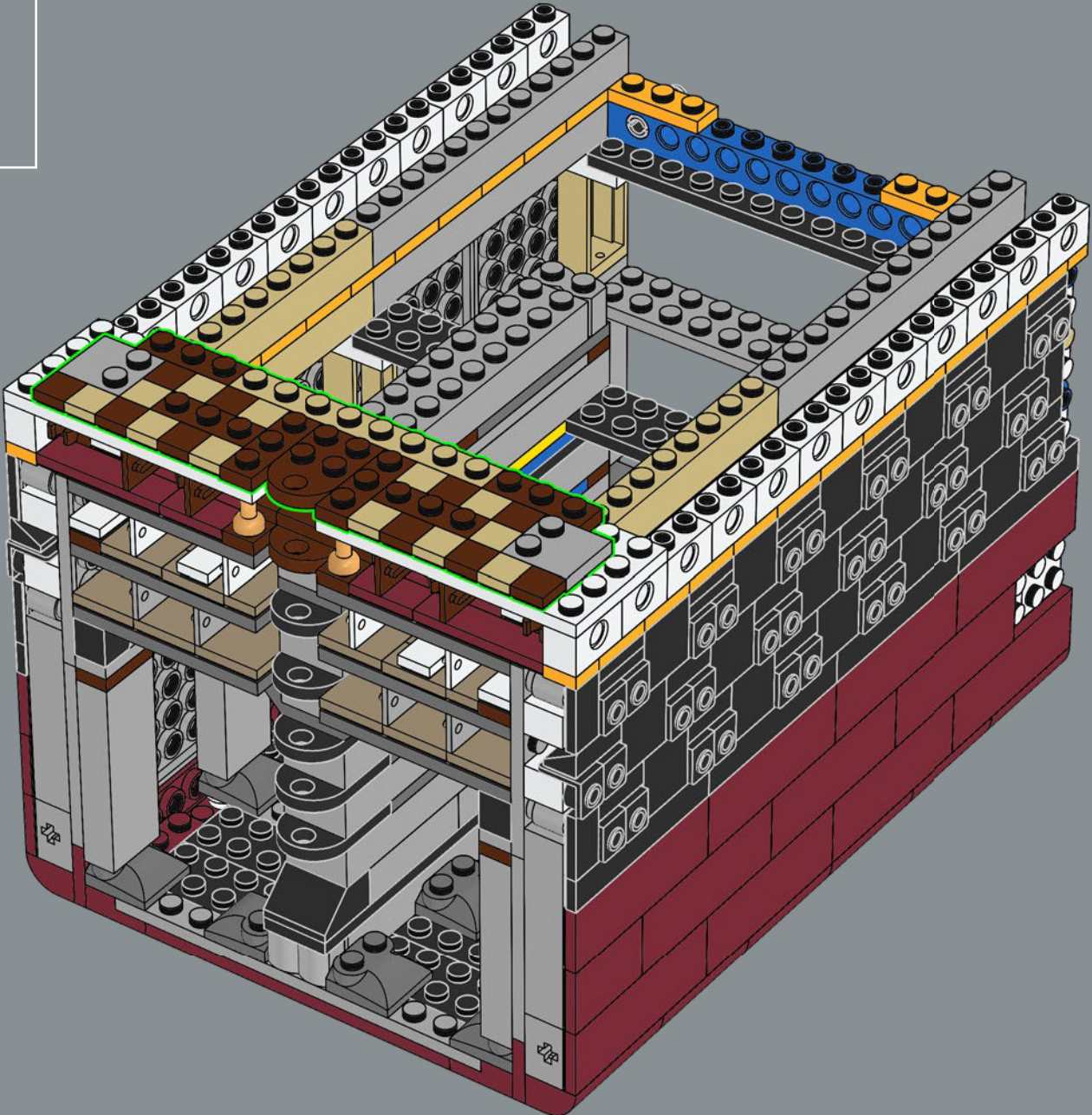



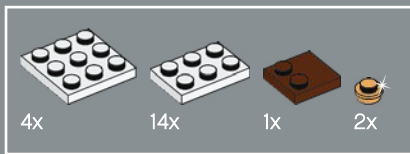

207

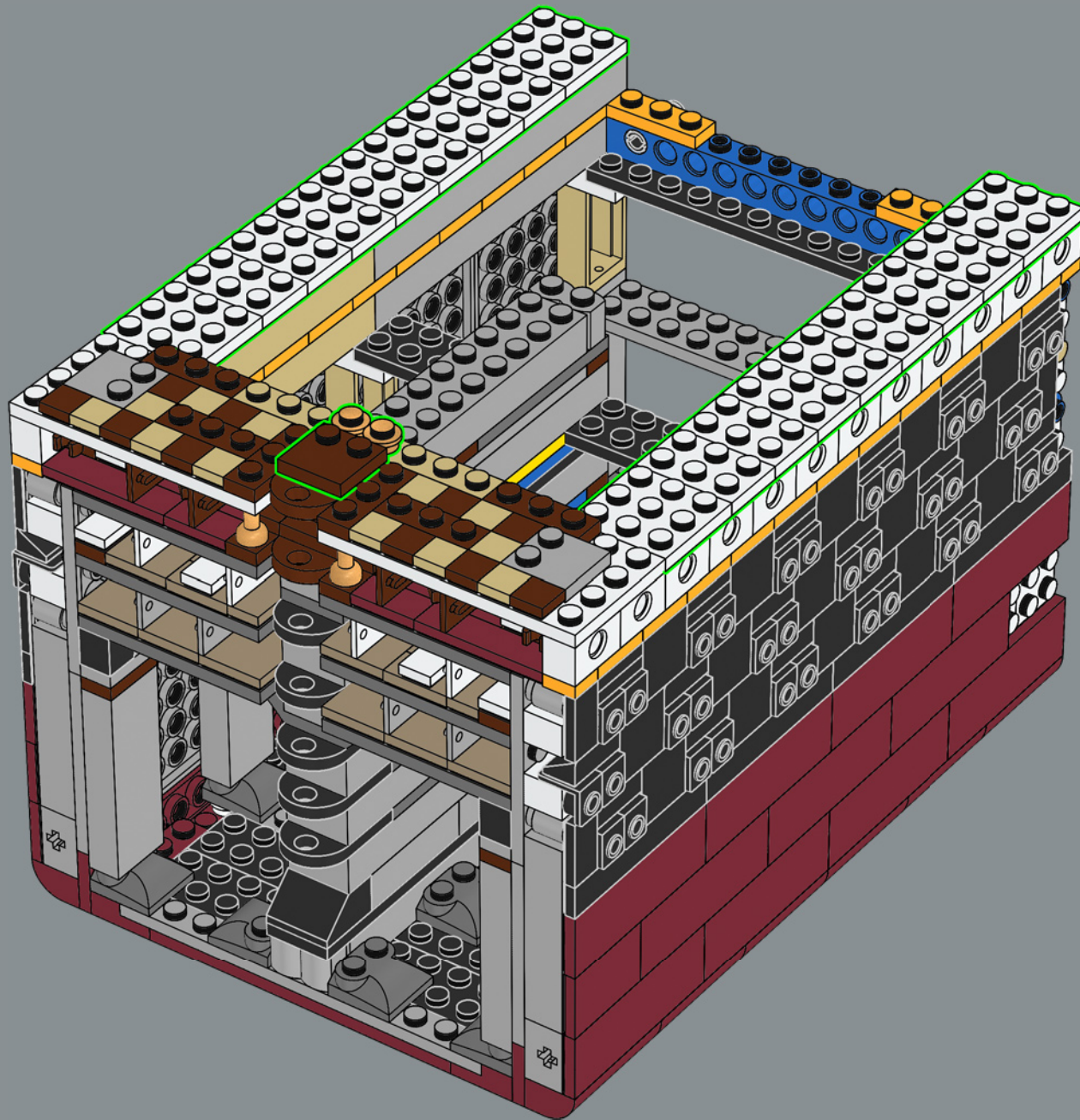

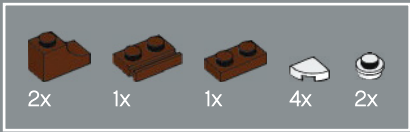

208

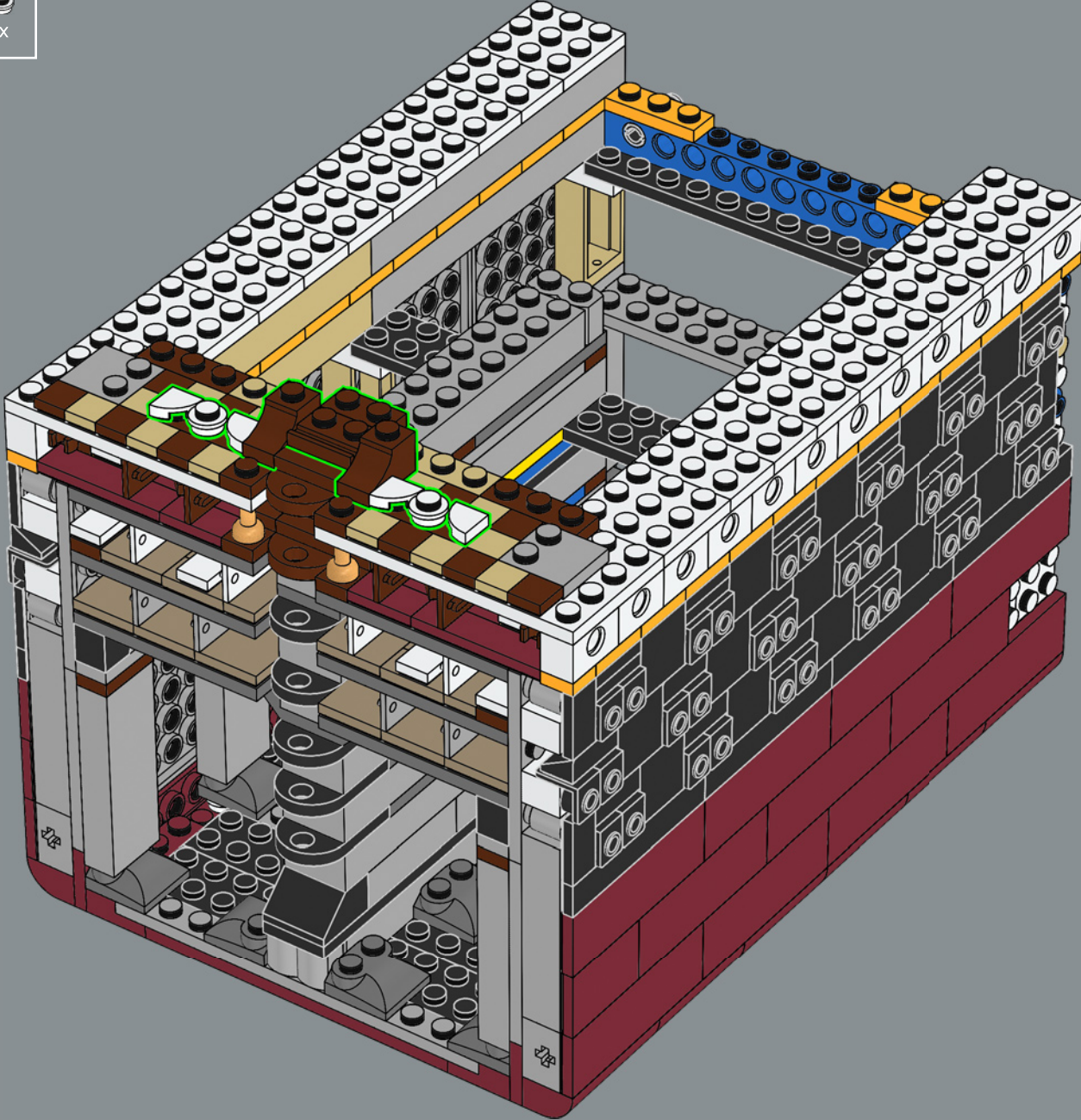

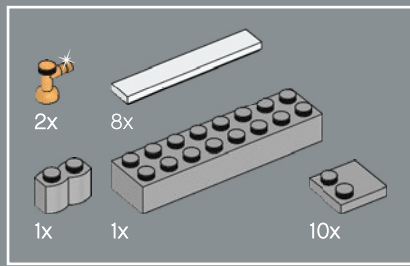

209

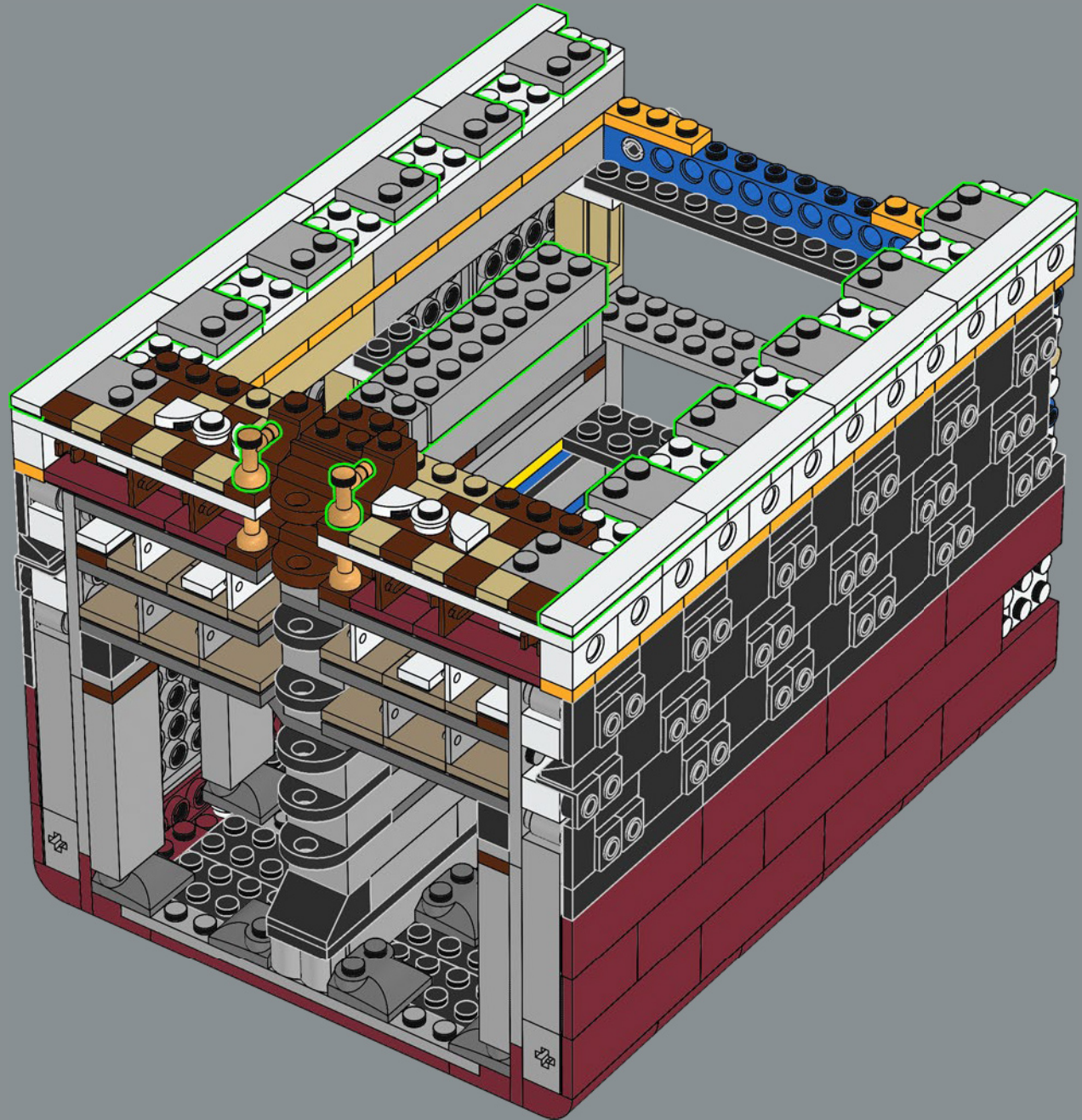

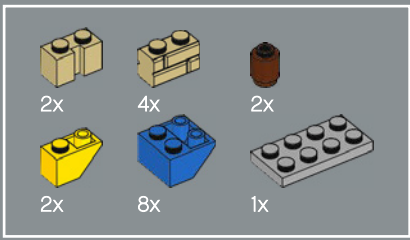

210

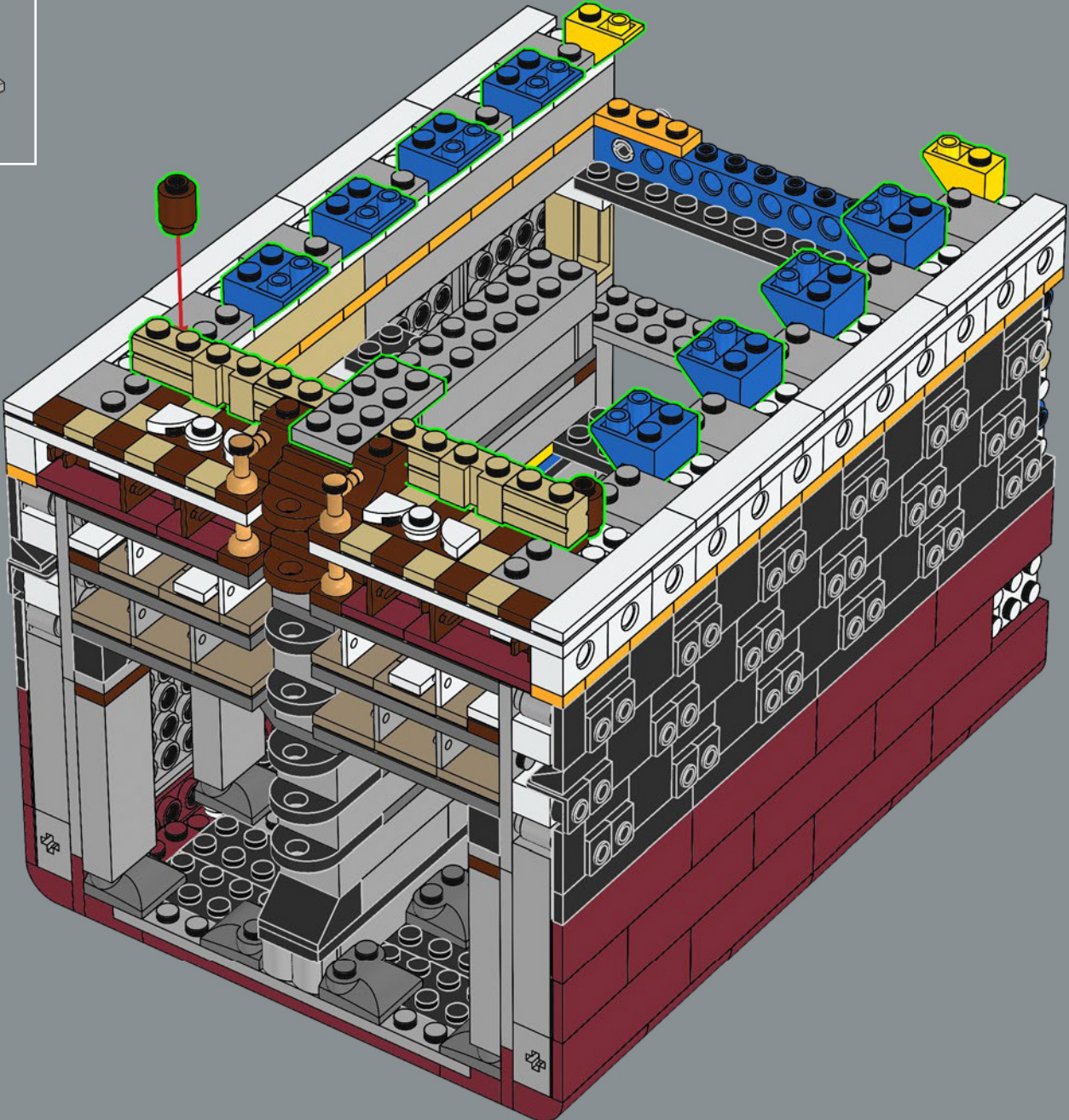

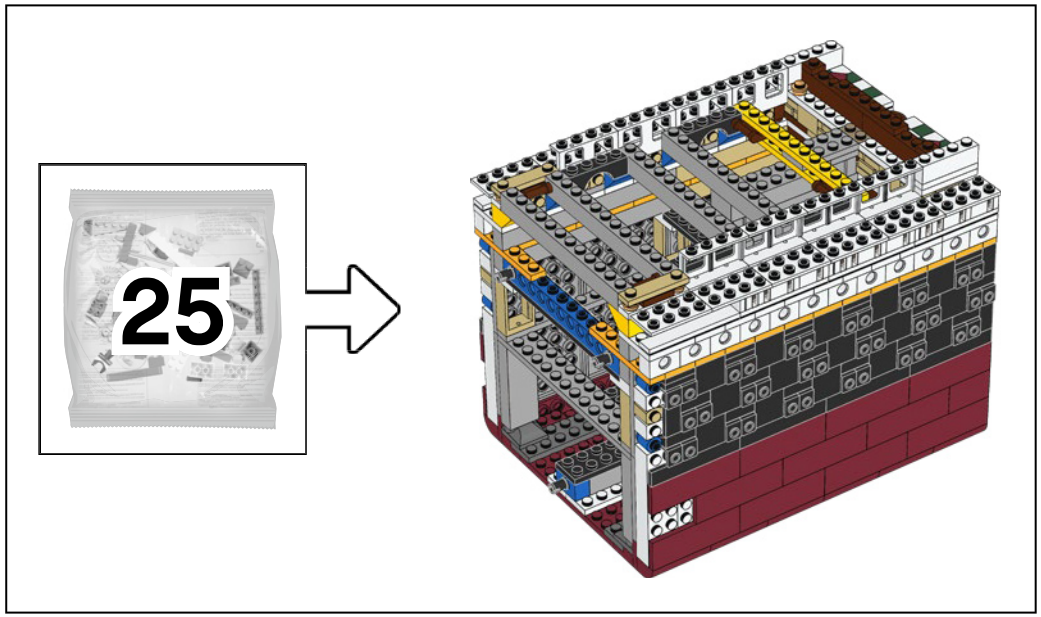

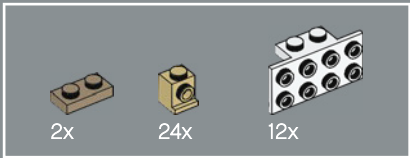

211

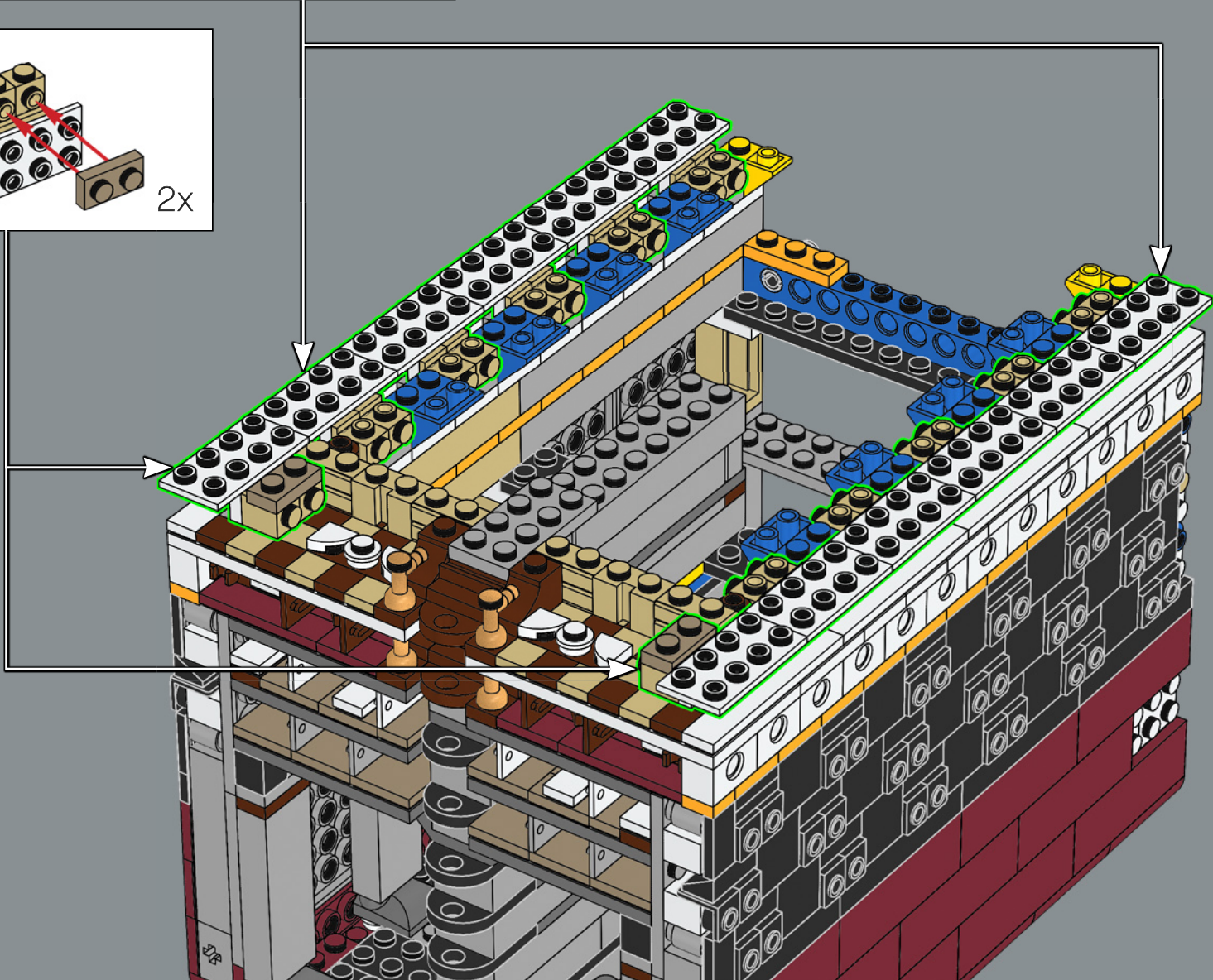
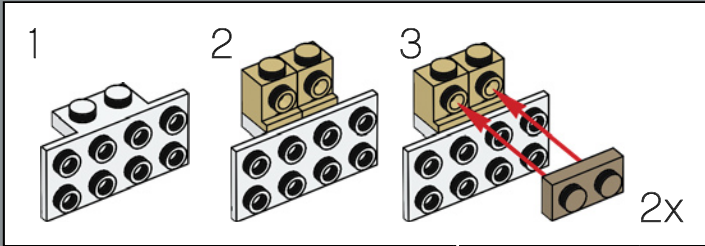
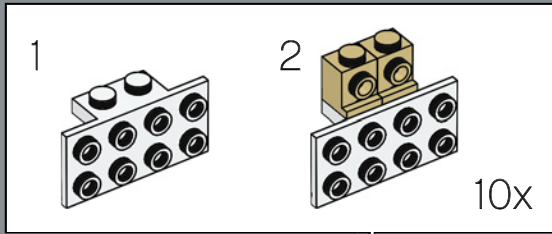

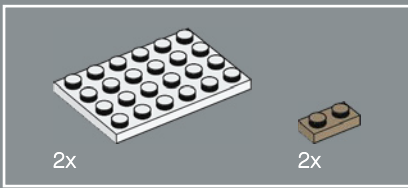

212

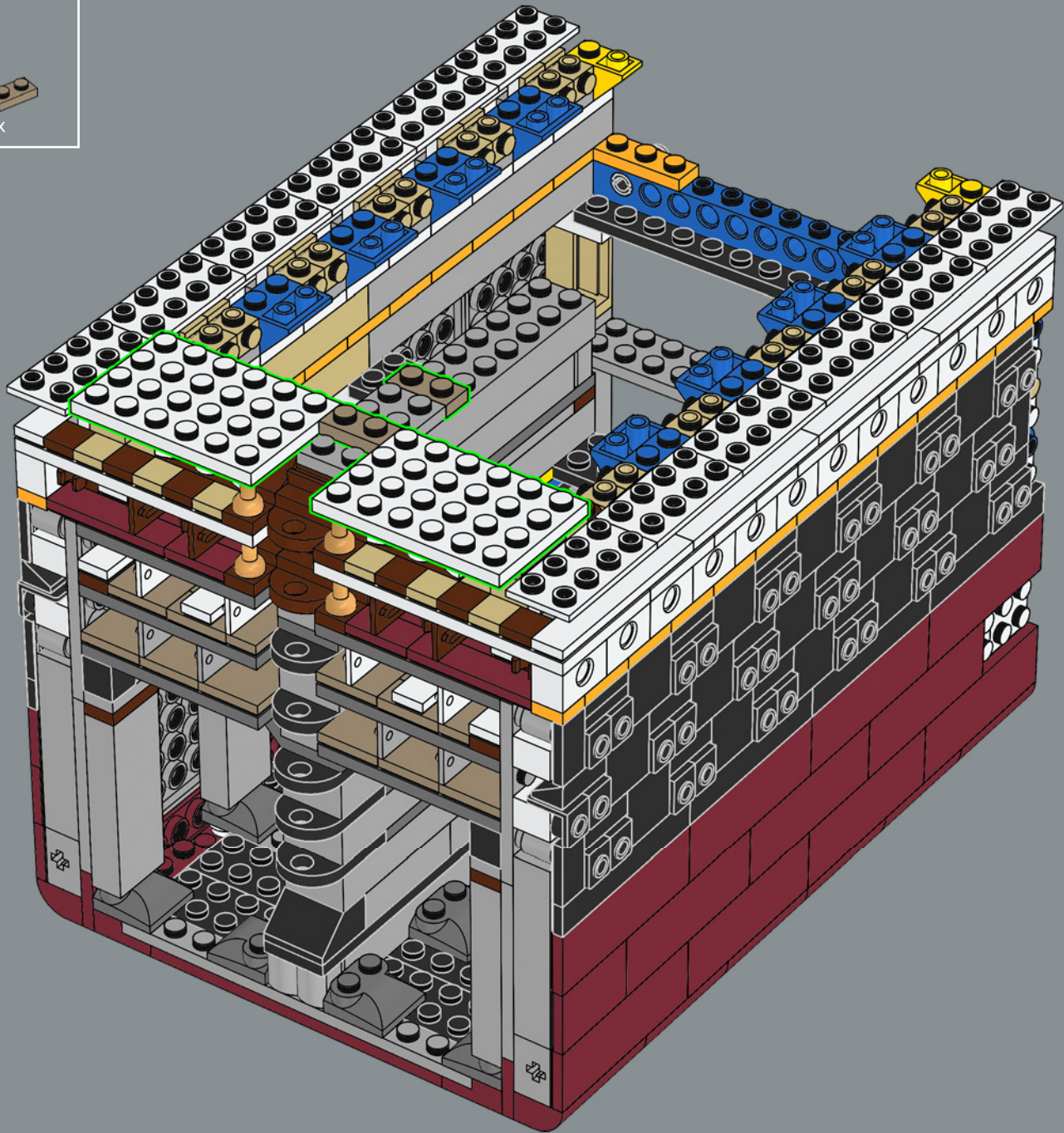

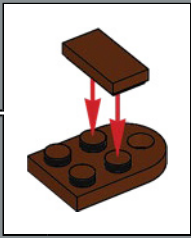
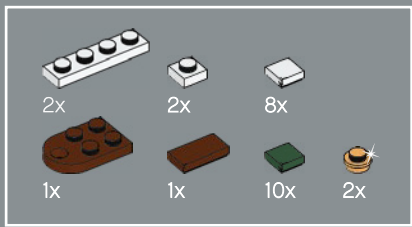

213

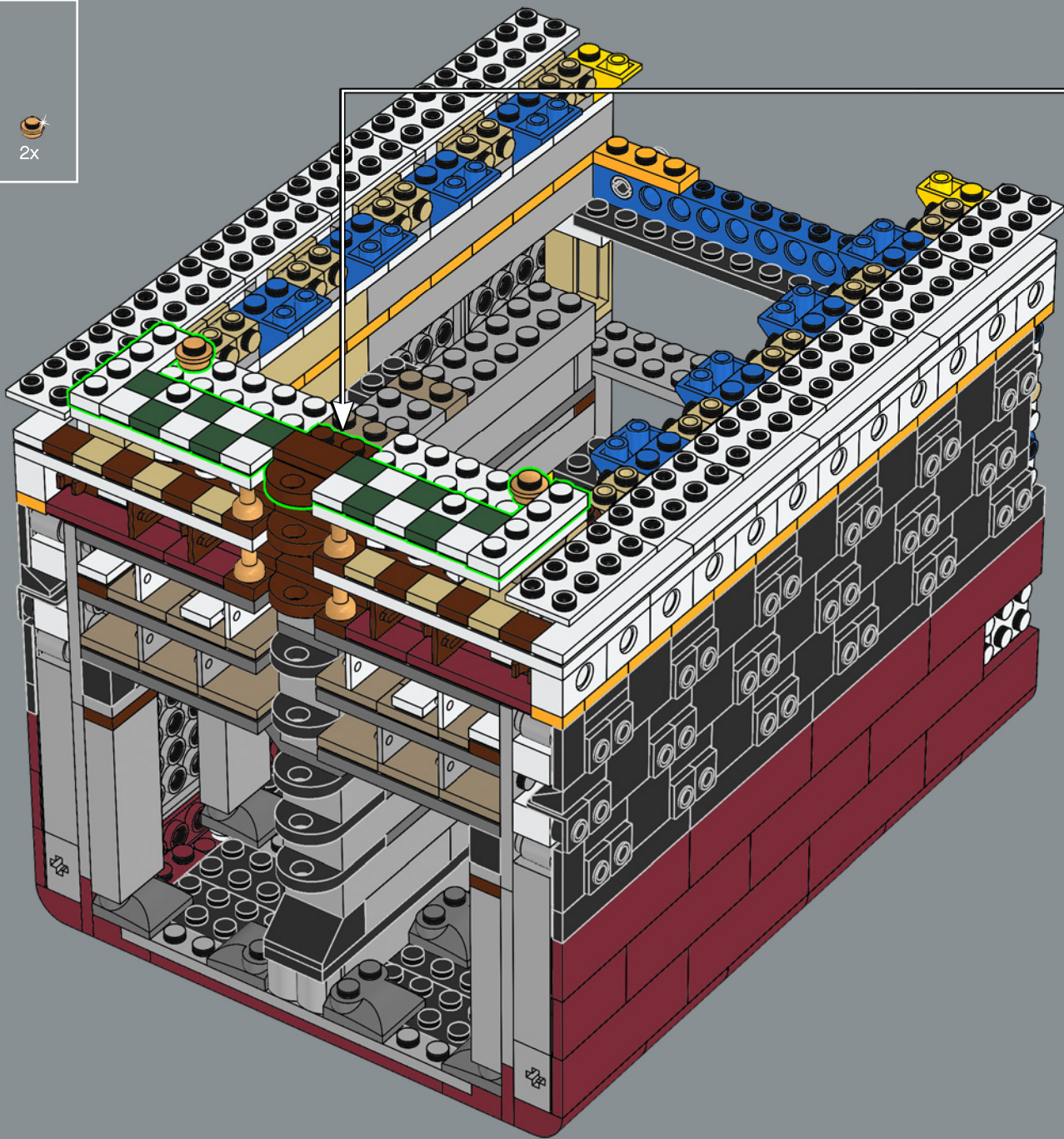



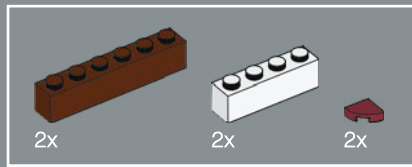

214

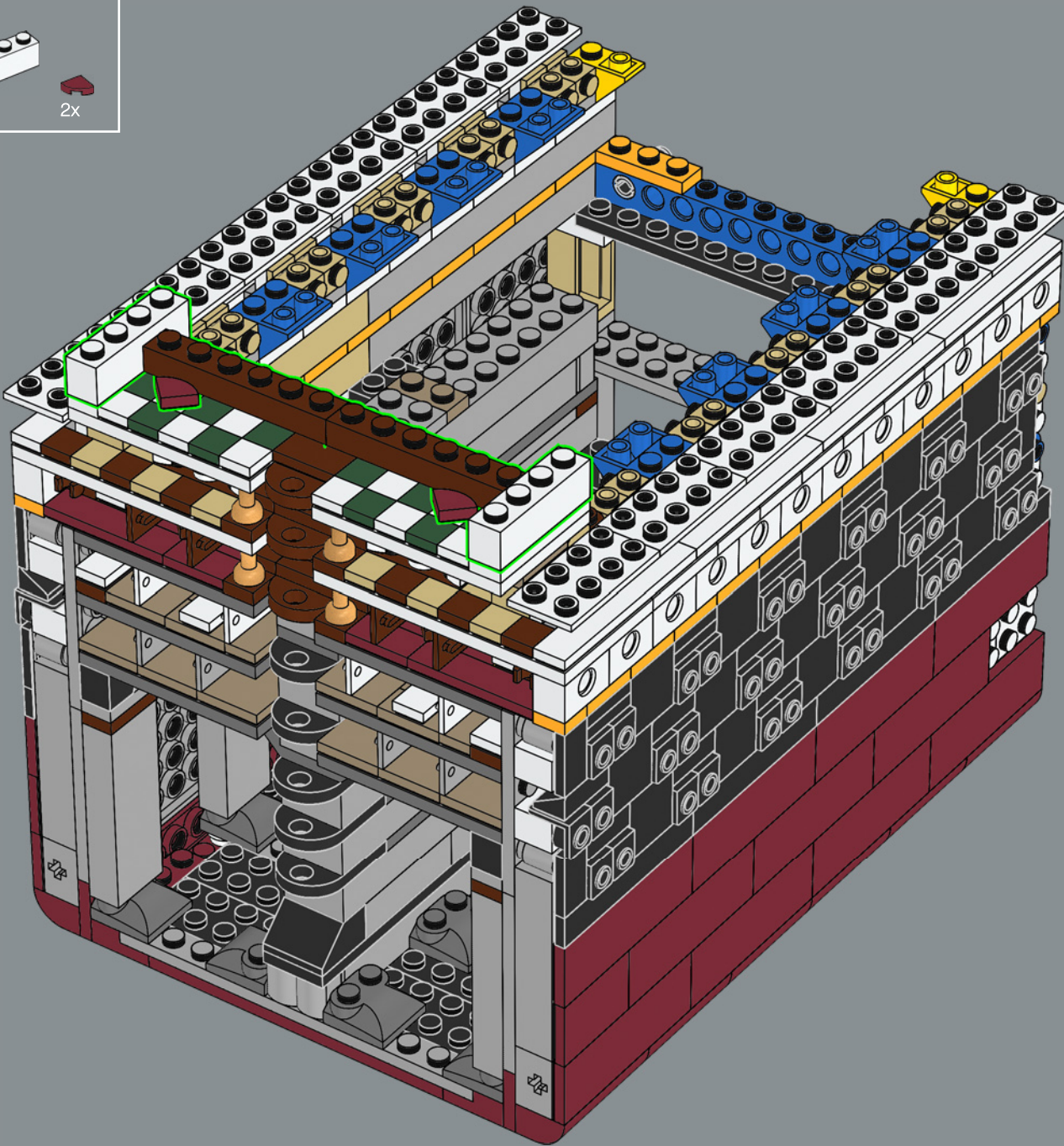

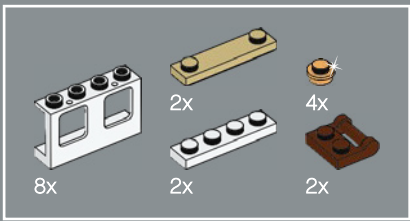

215

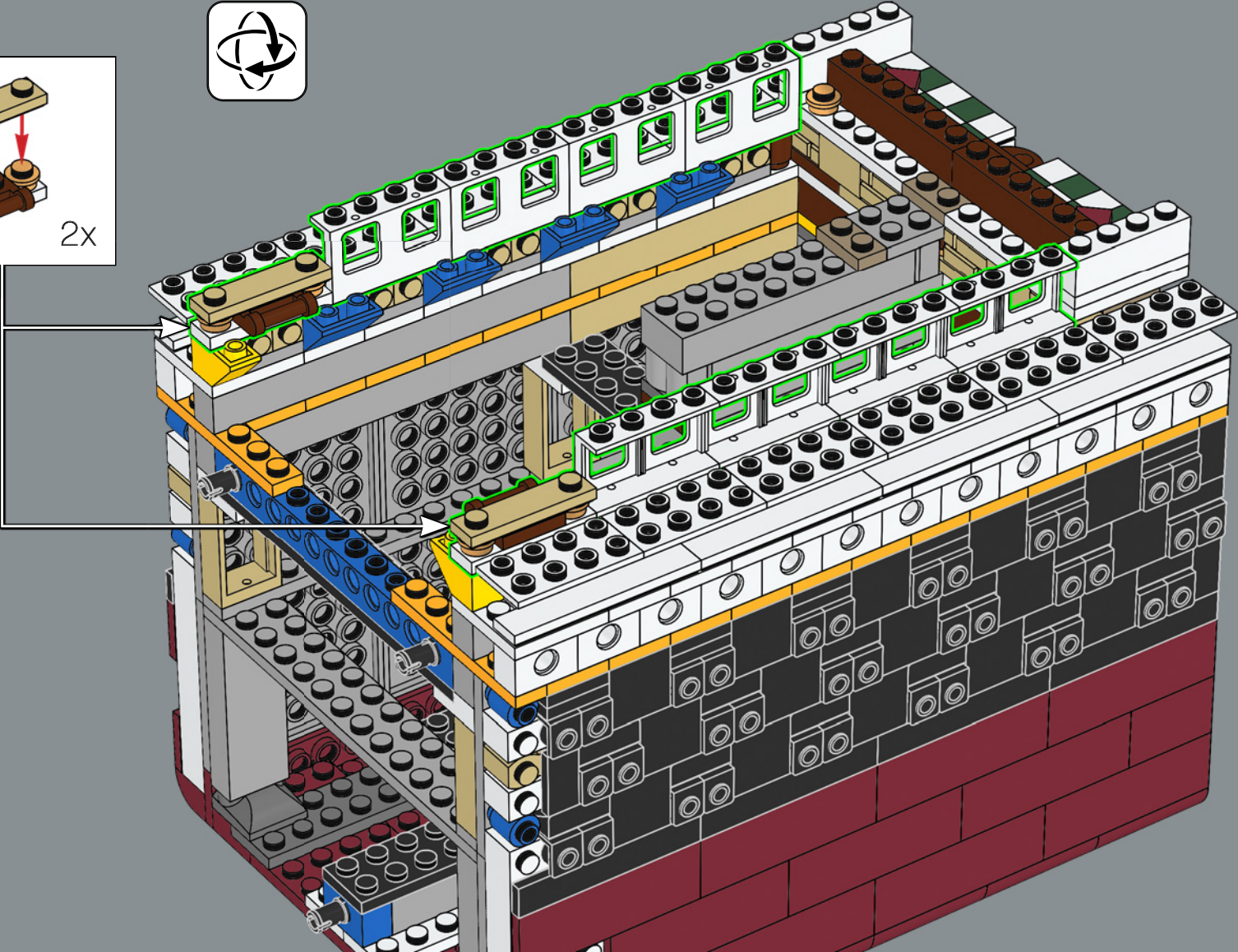
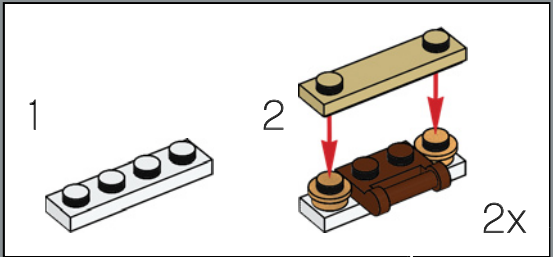

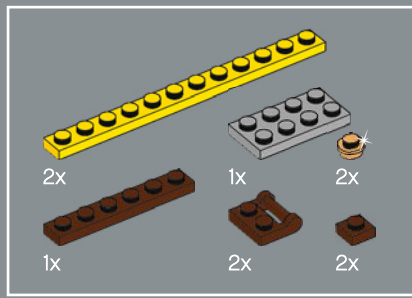

216

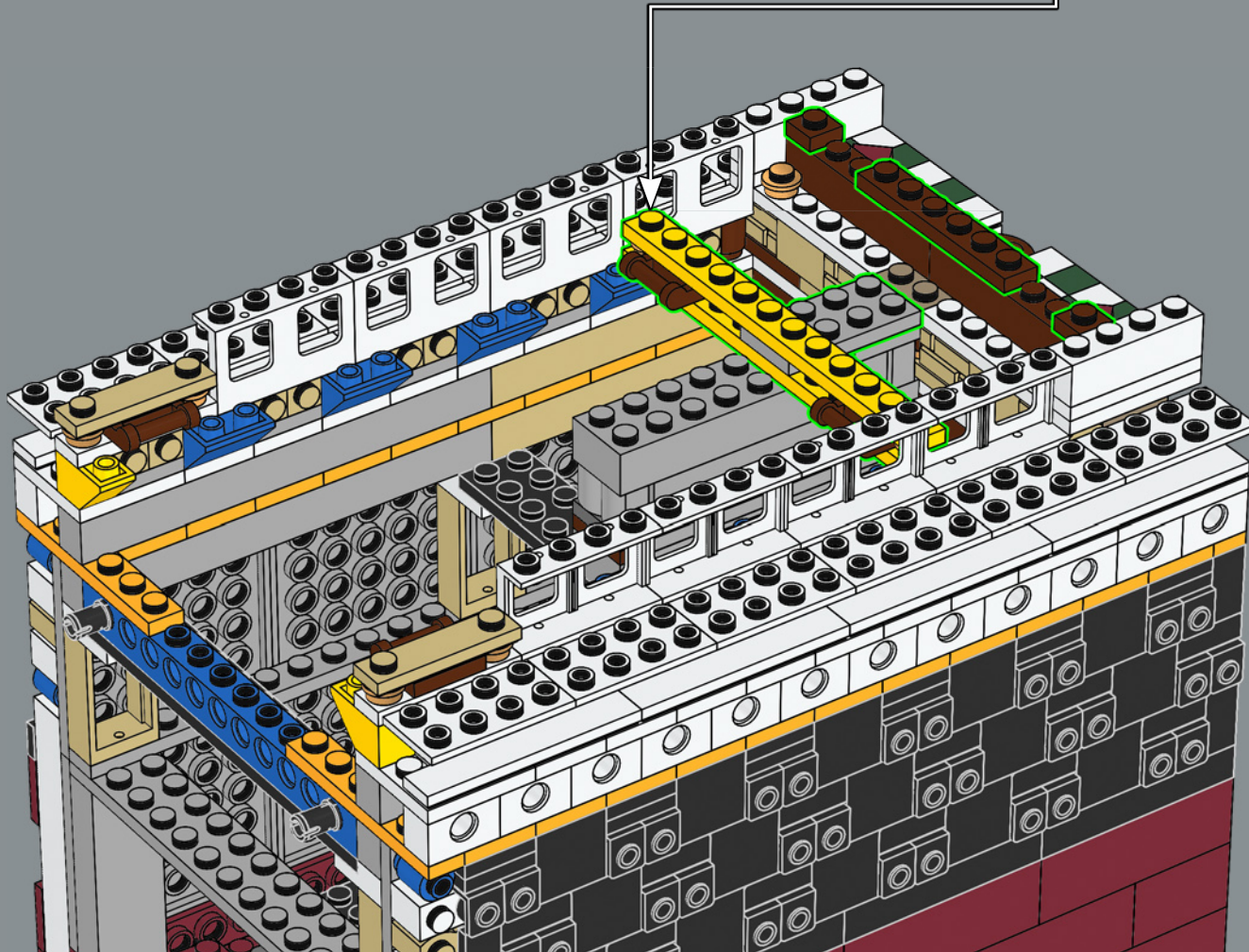
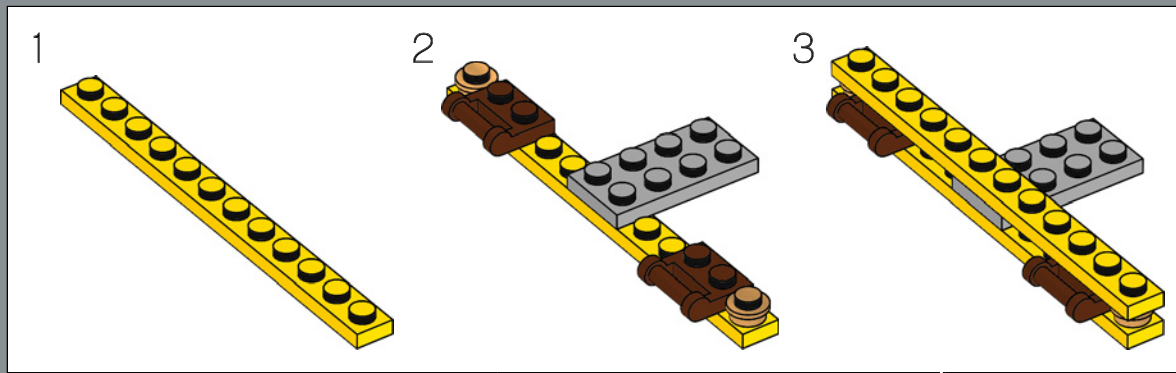

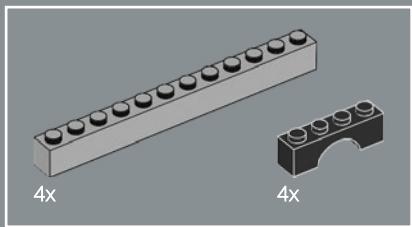

217

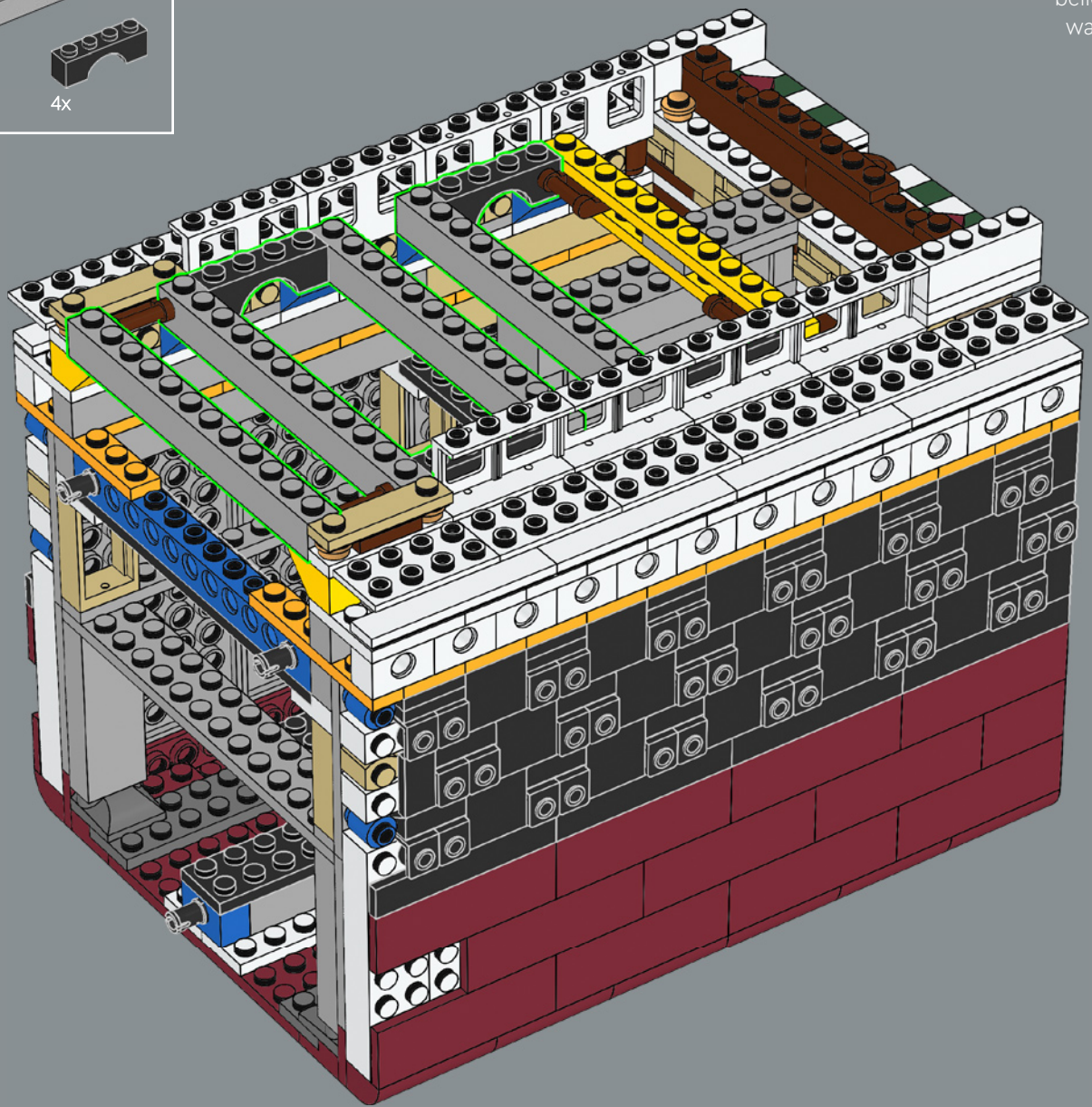

Die Baukosten der *Titanic* und der *Olympic* beliefen sich auf 3 Millionen Britische Pfund, was heute einem Betrag von 300 Millionen Britischen Pfund entspricht.

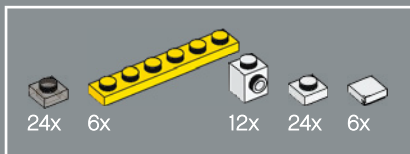

218

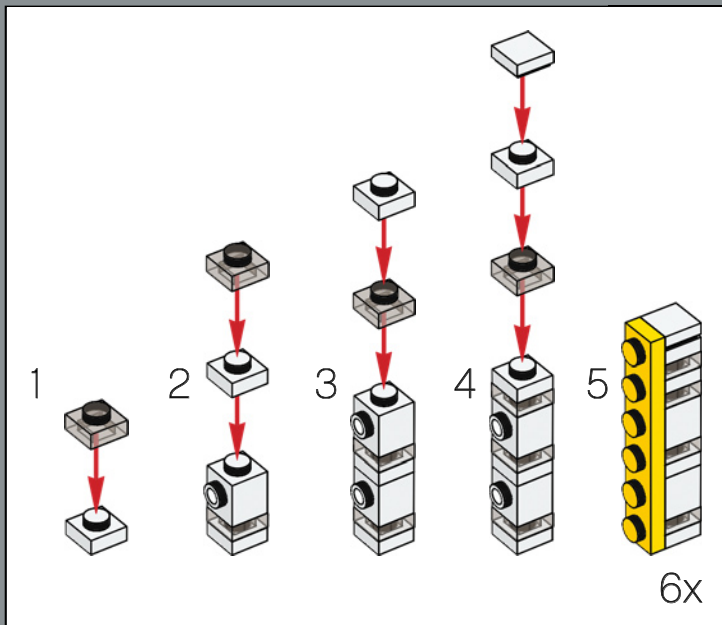
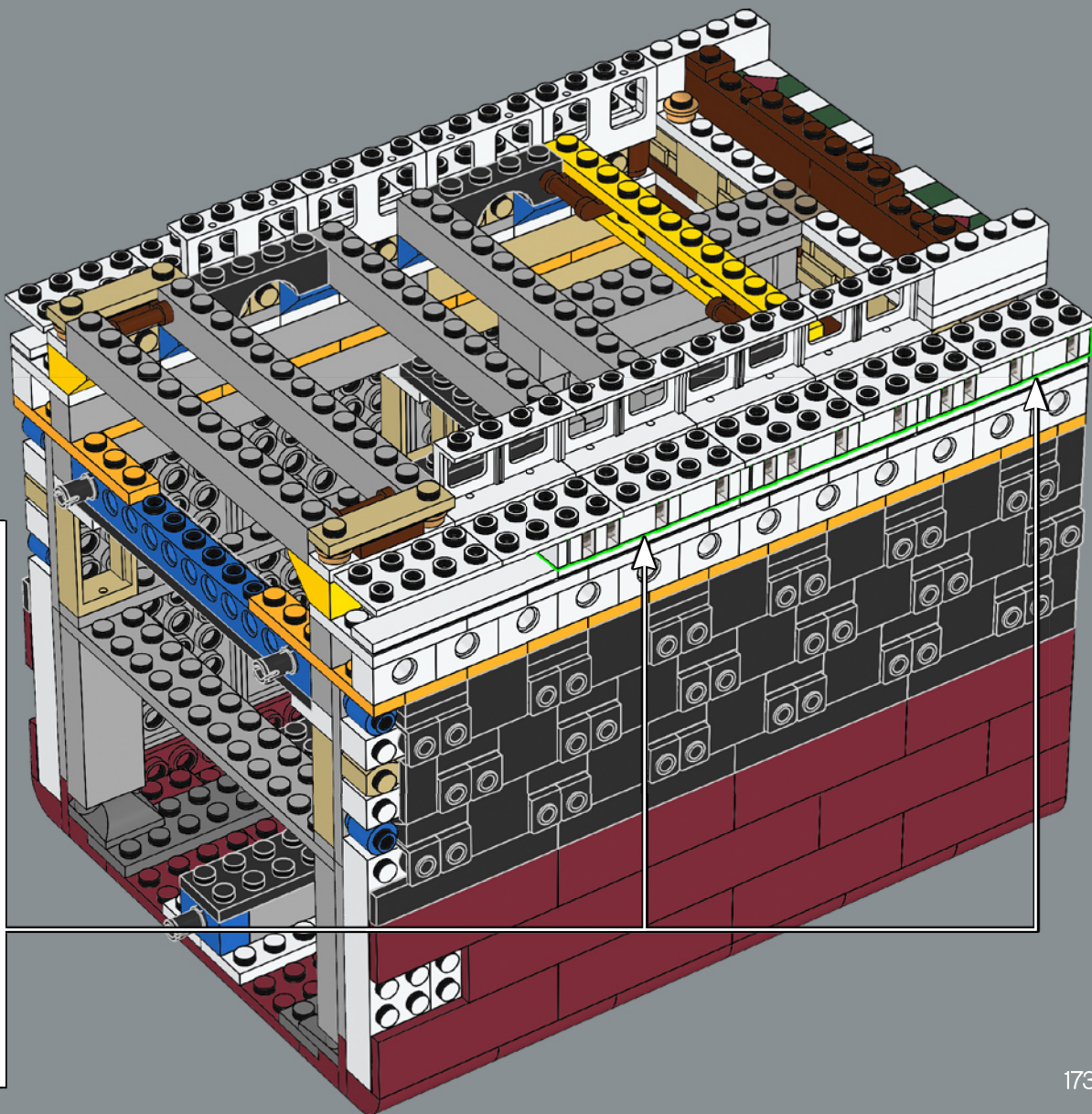

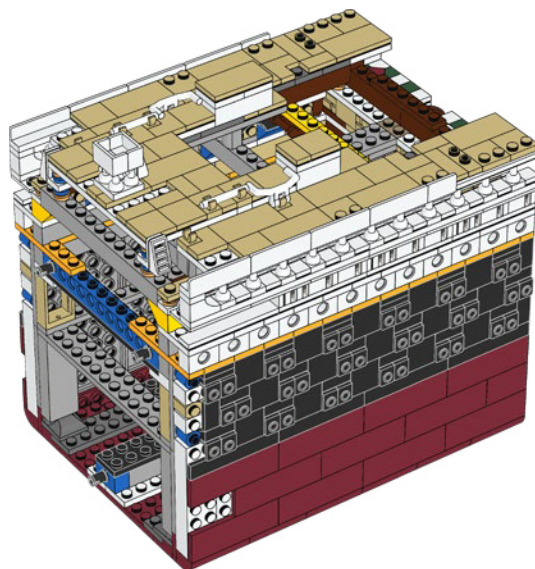
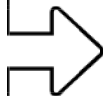

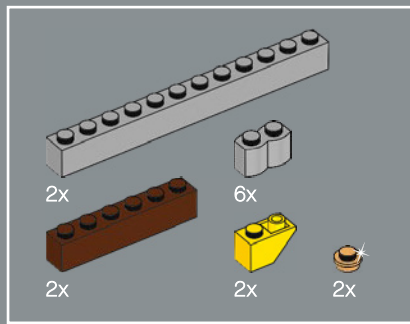

219

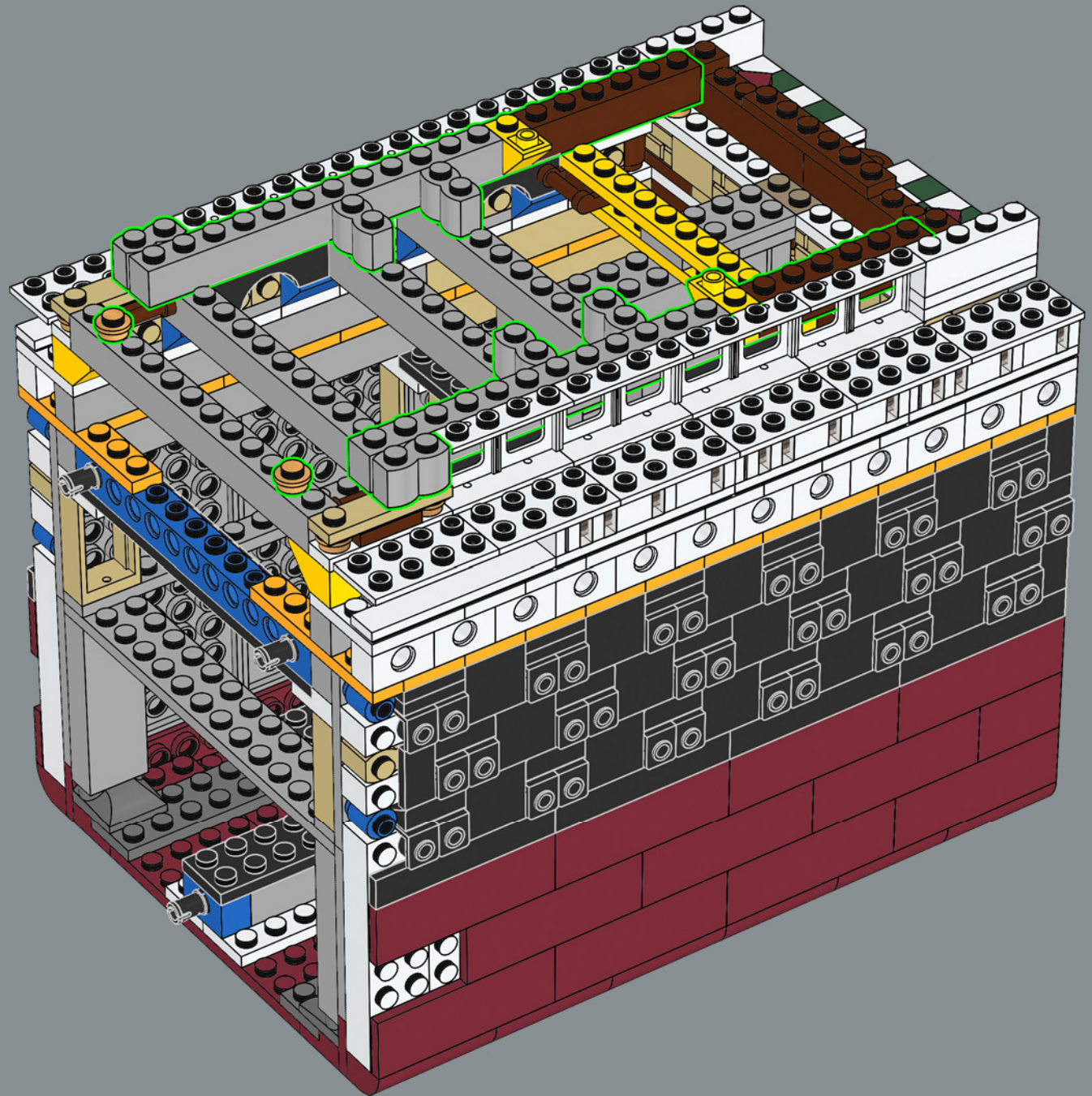

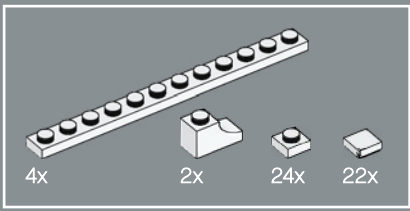

220

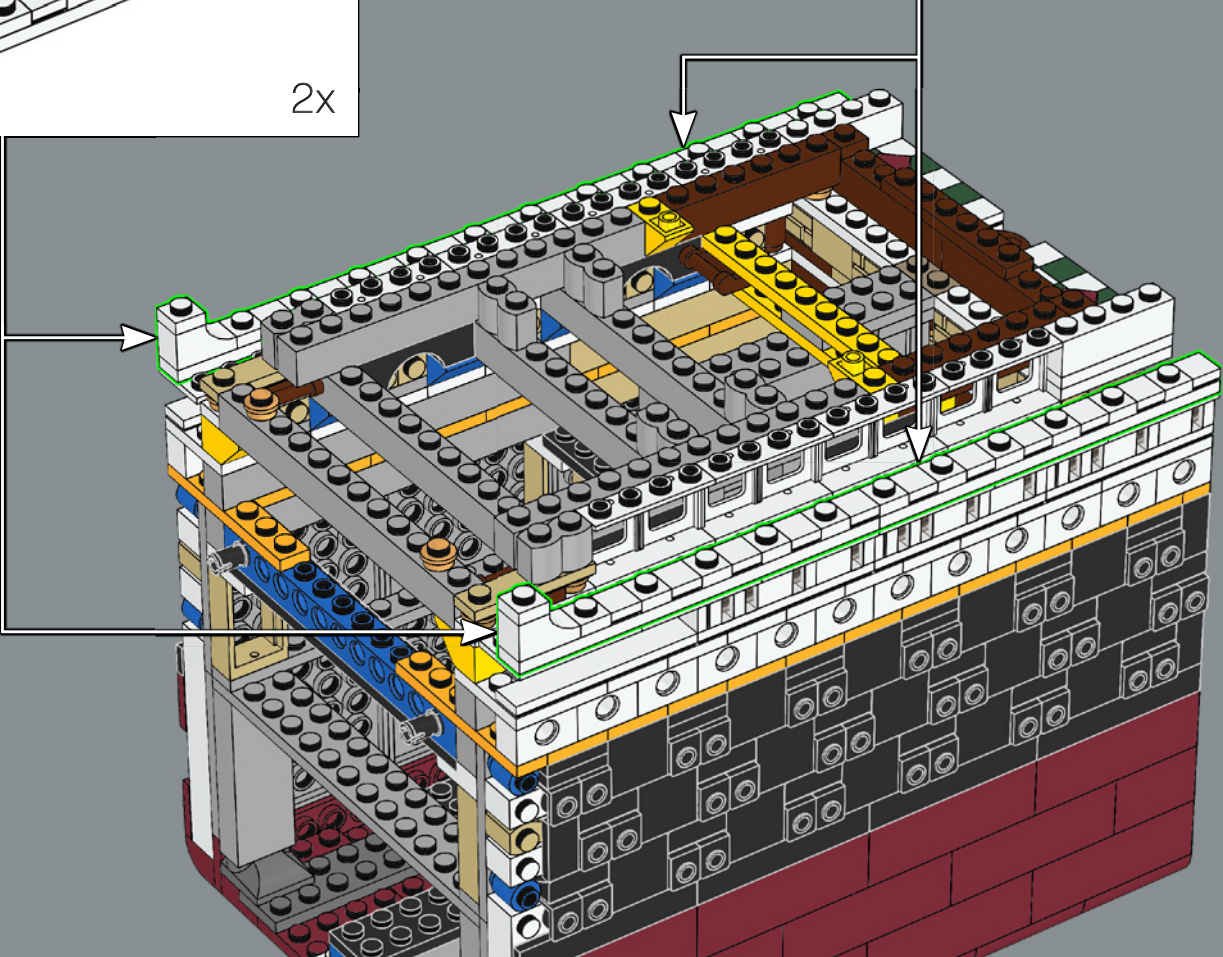
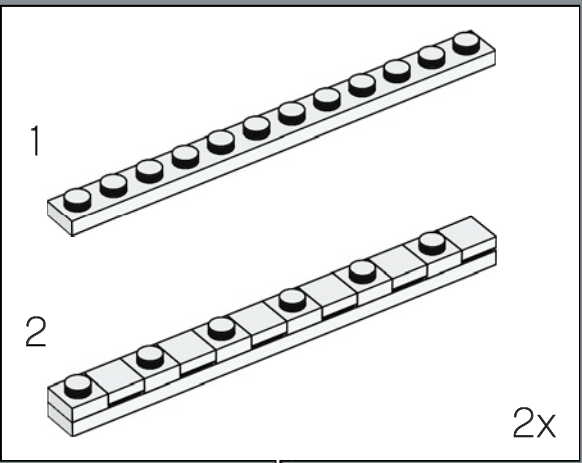
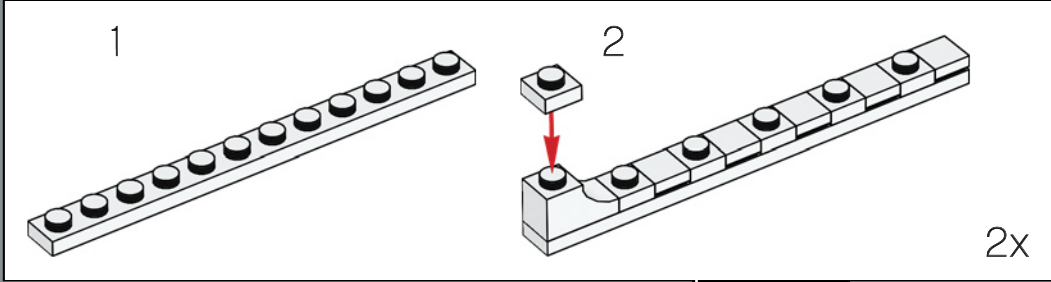



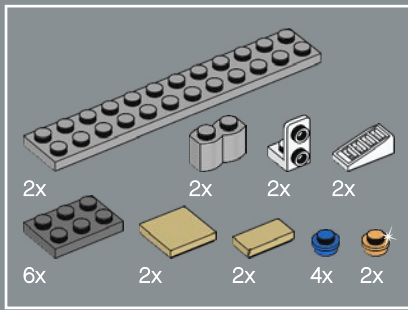

221

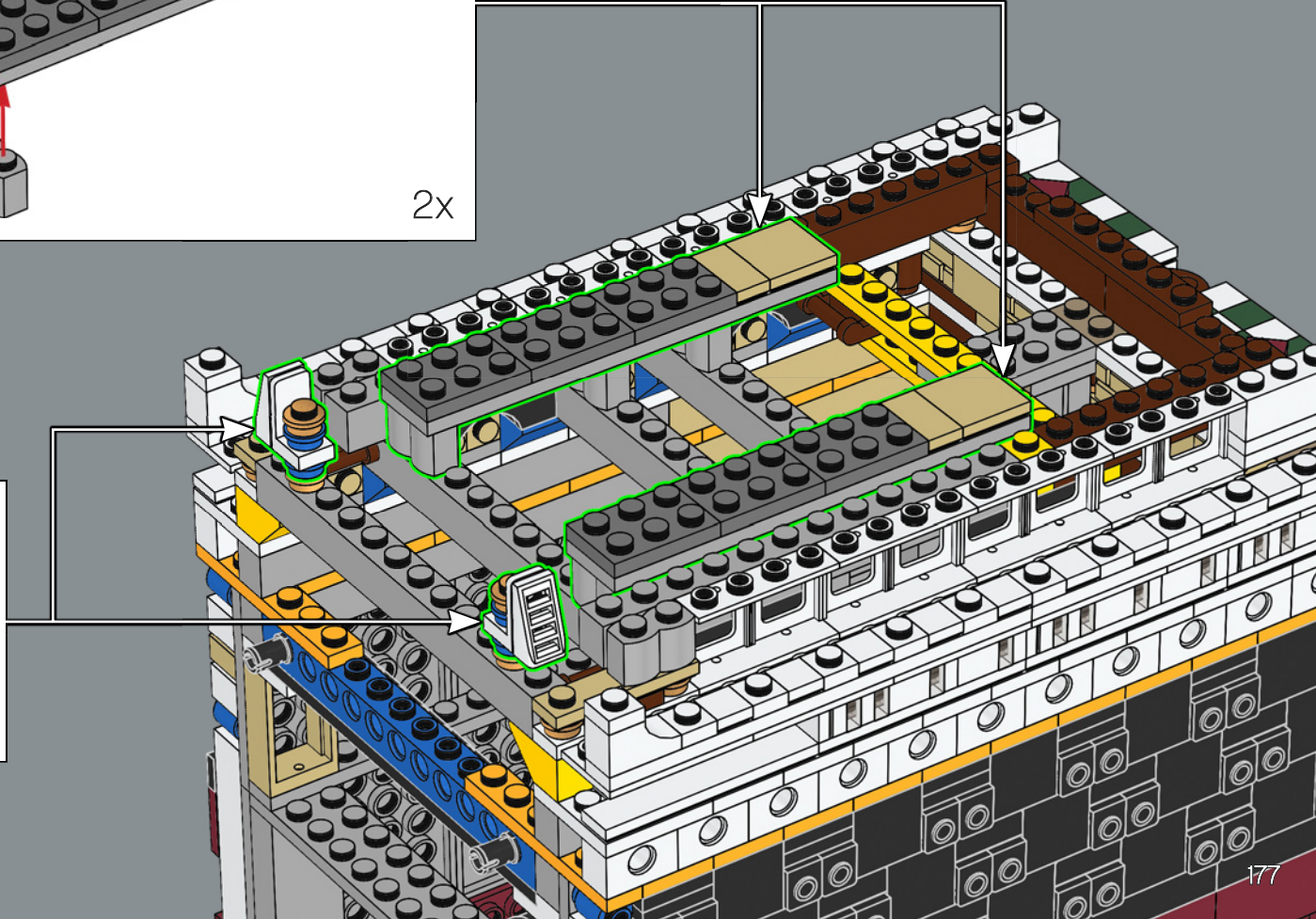
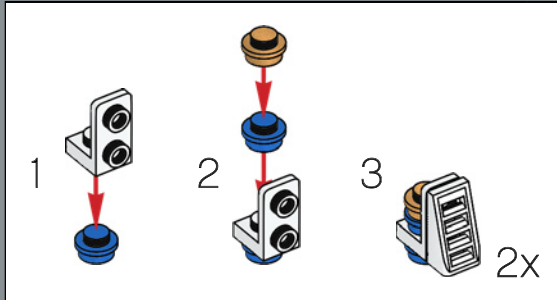
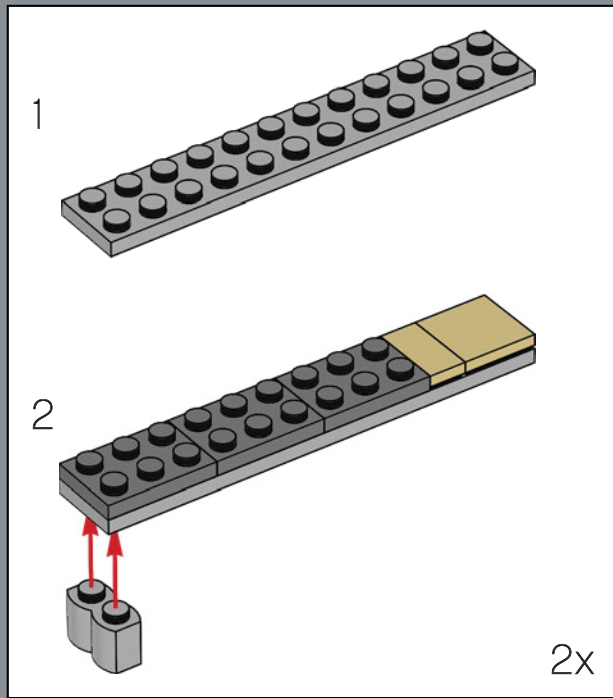

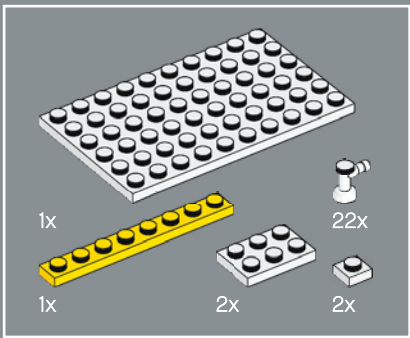

222

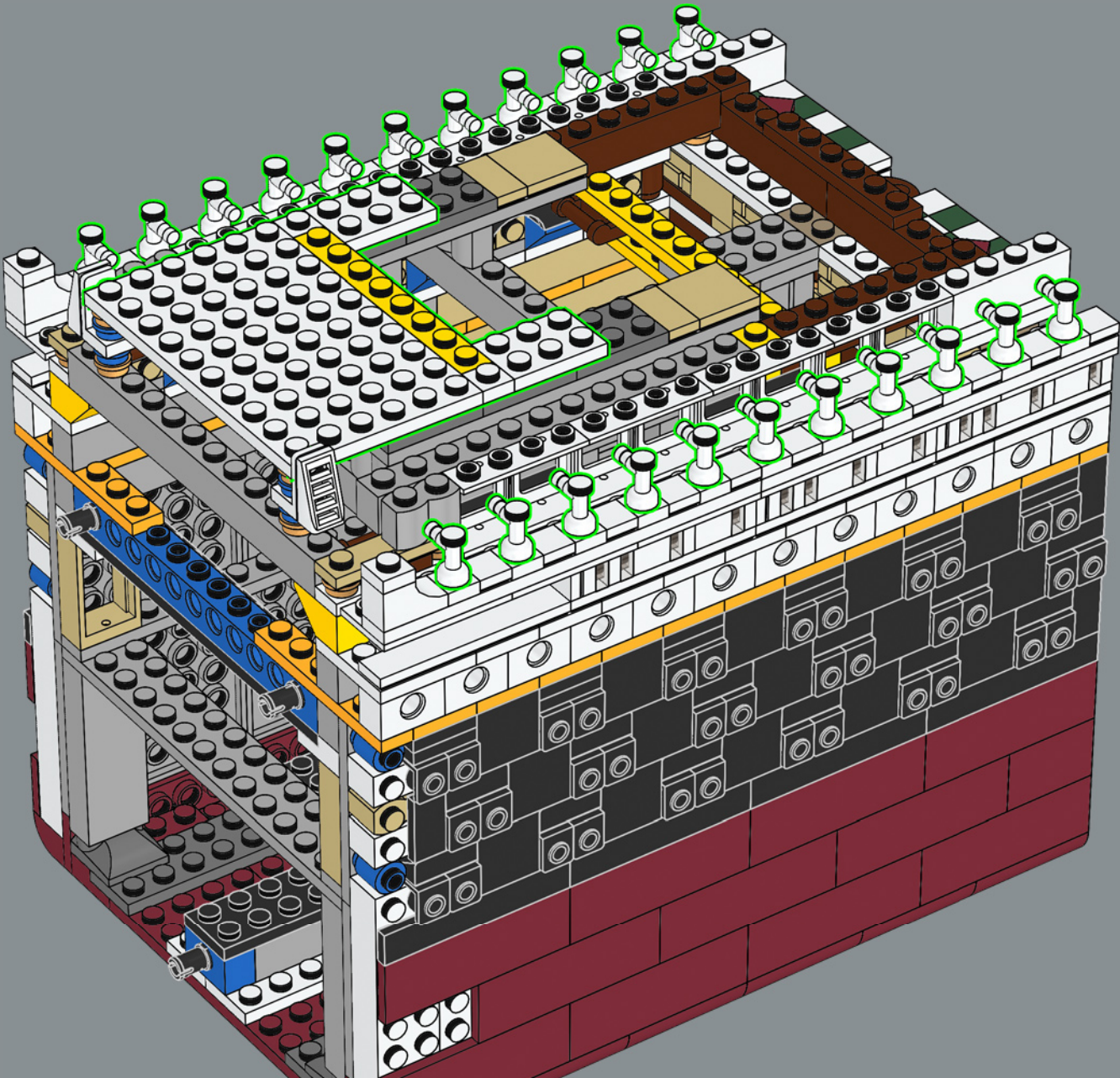

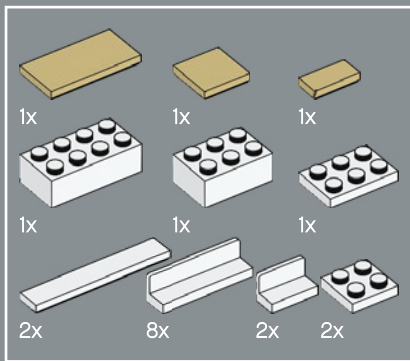

223

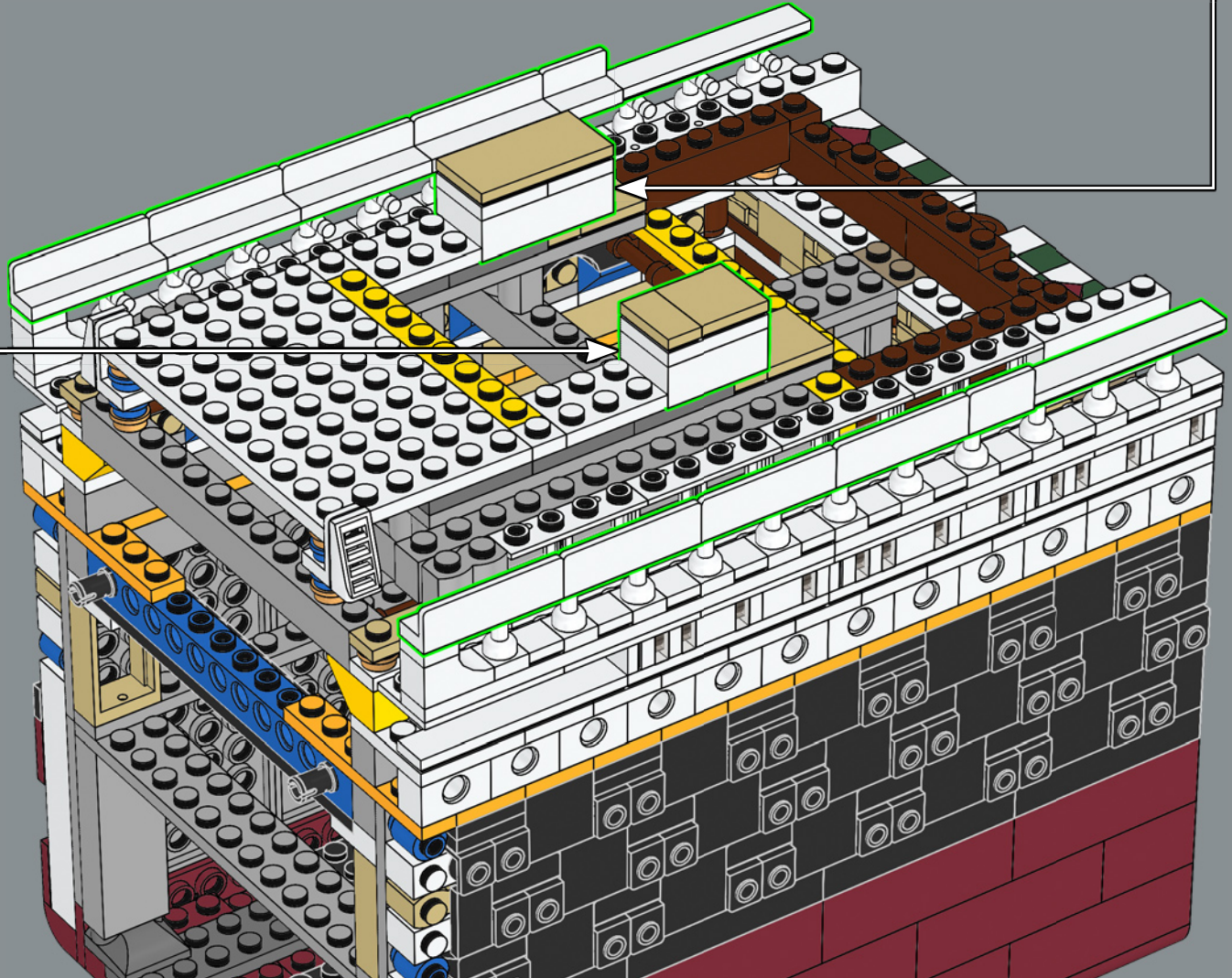
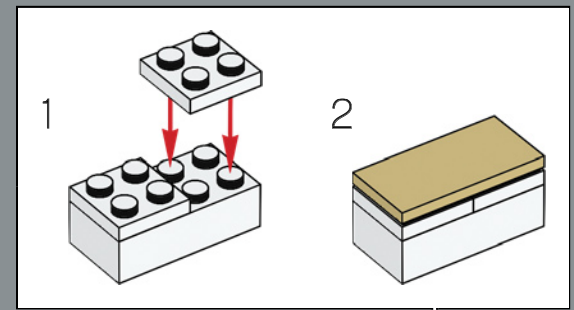
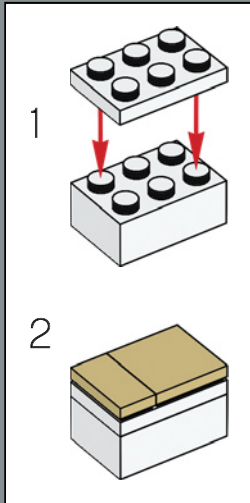

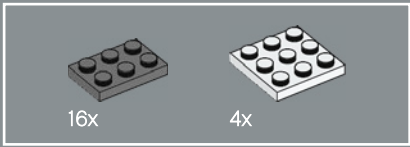

224

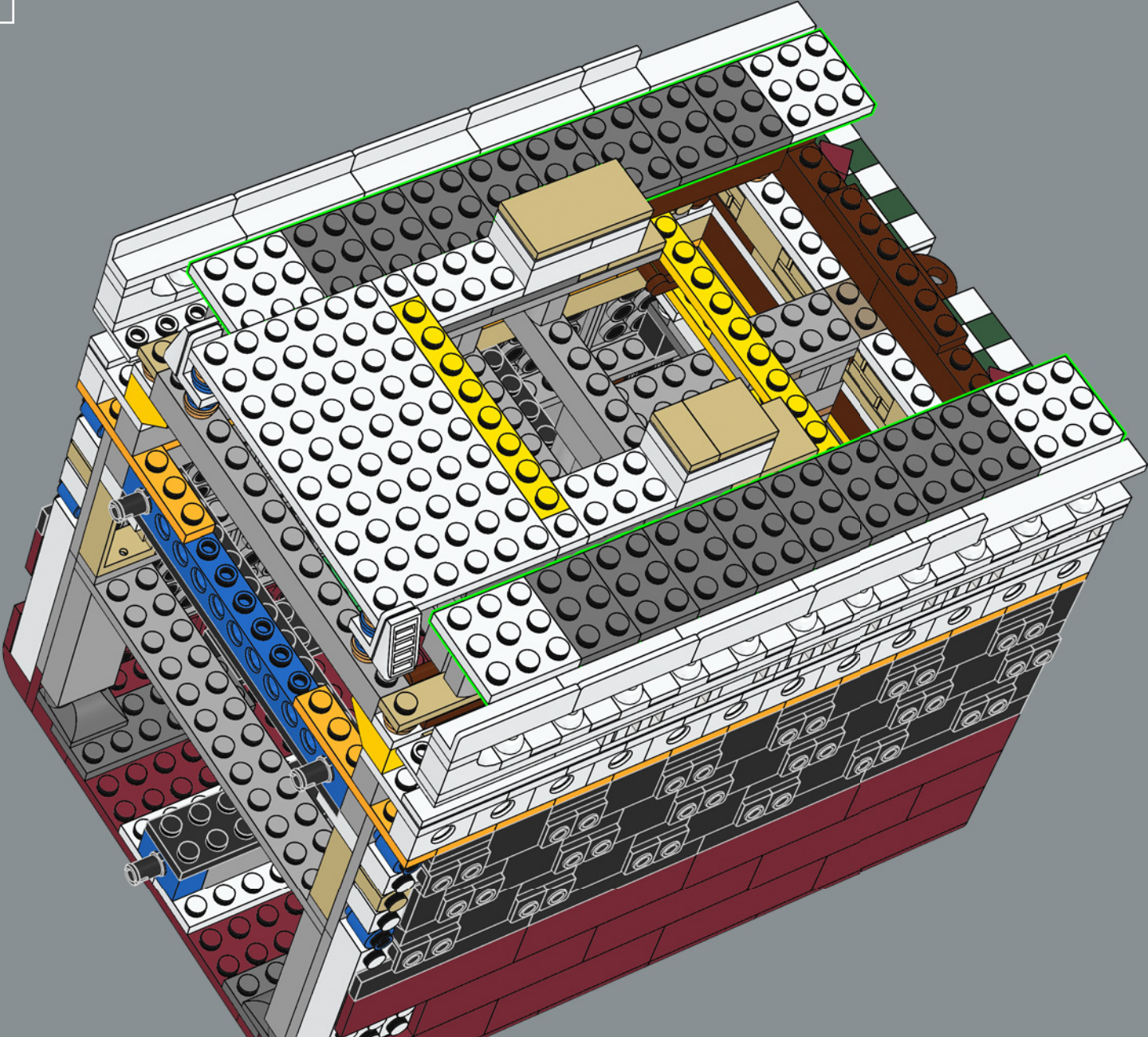

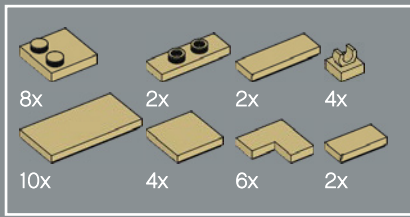

225

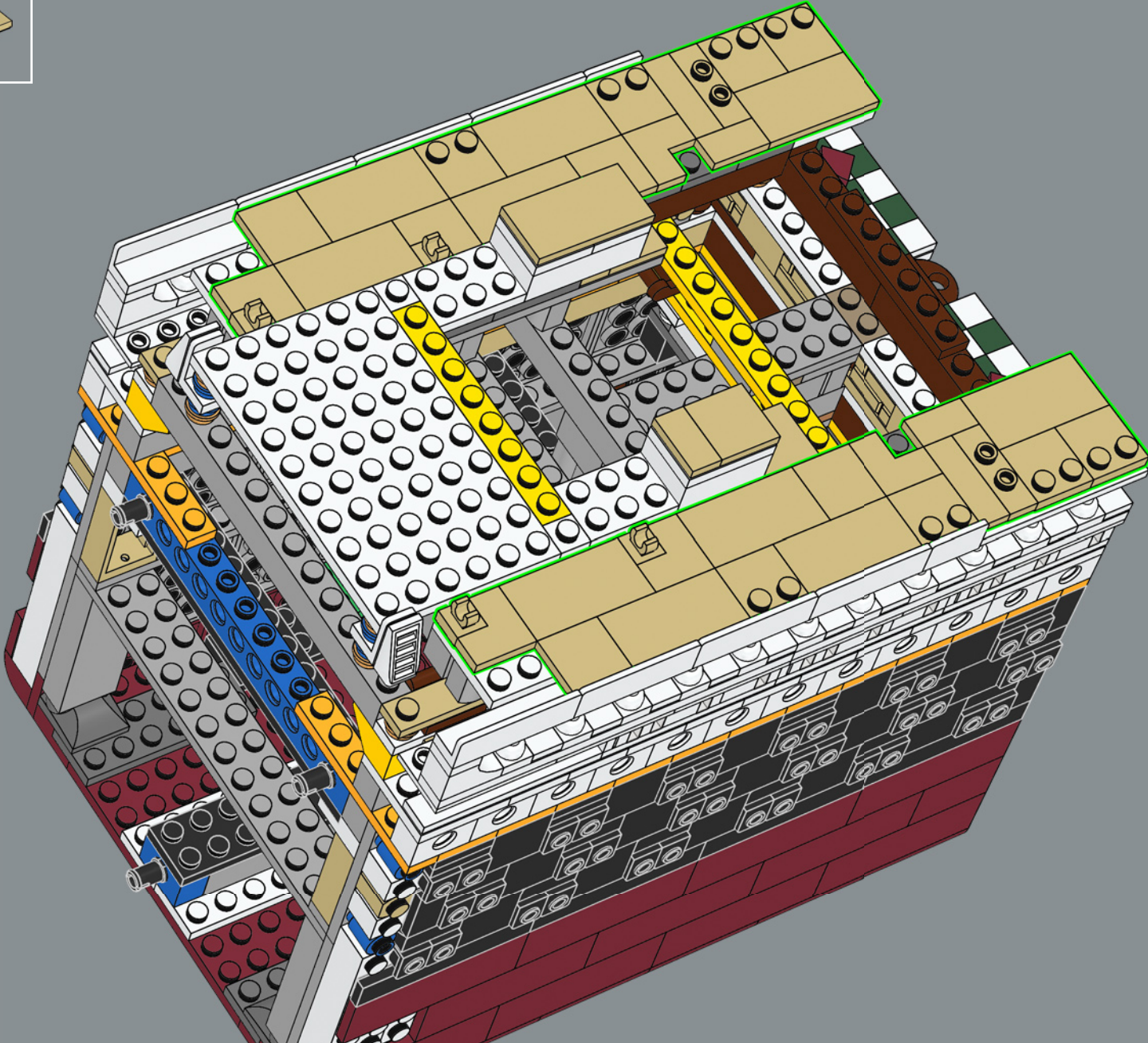

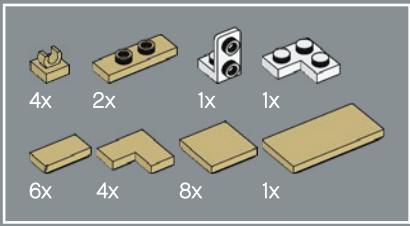

226

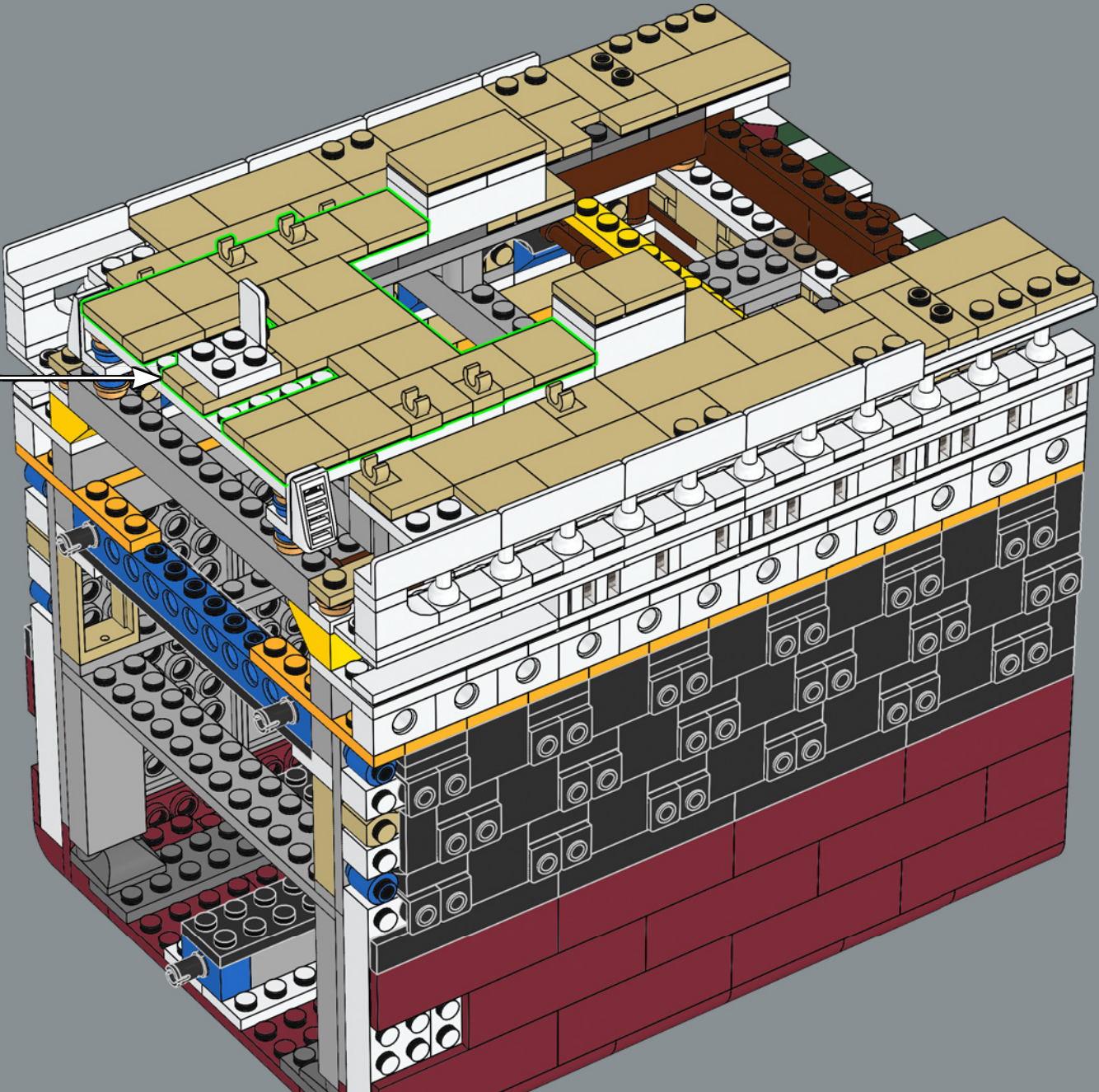
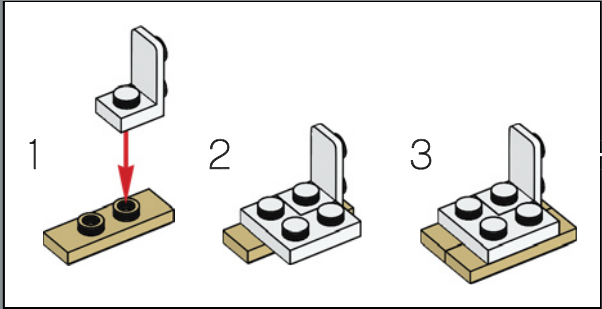



227

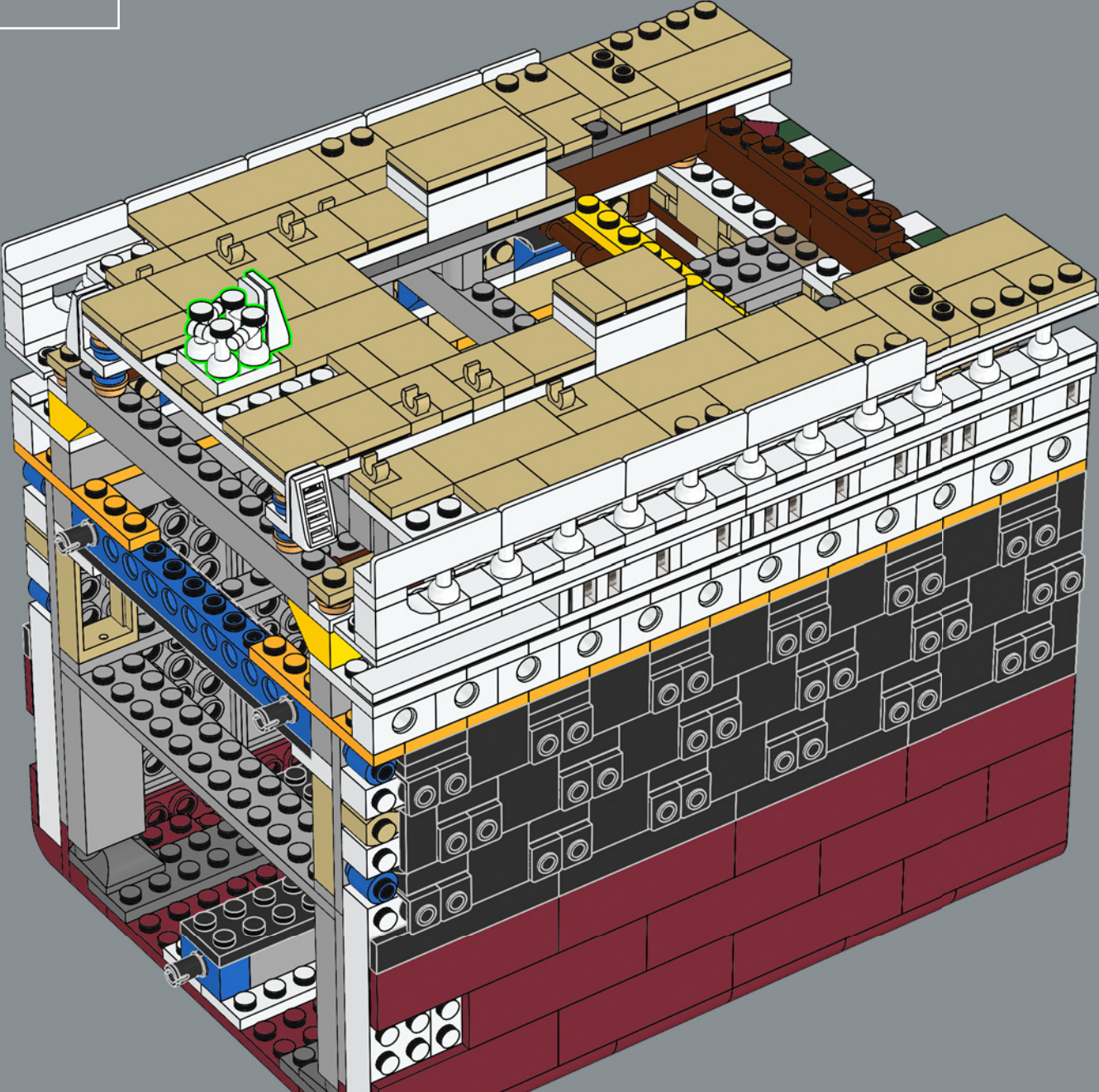

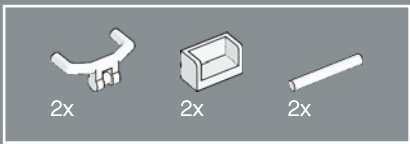

228

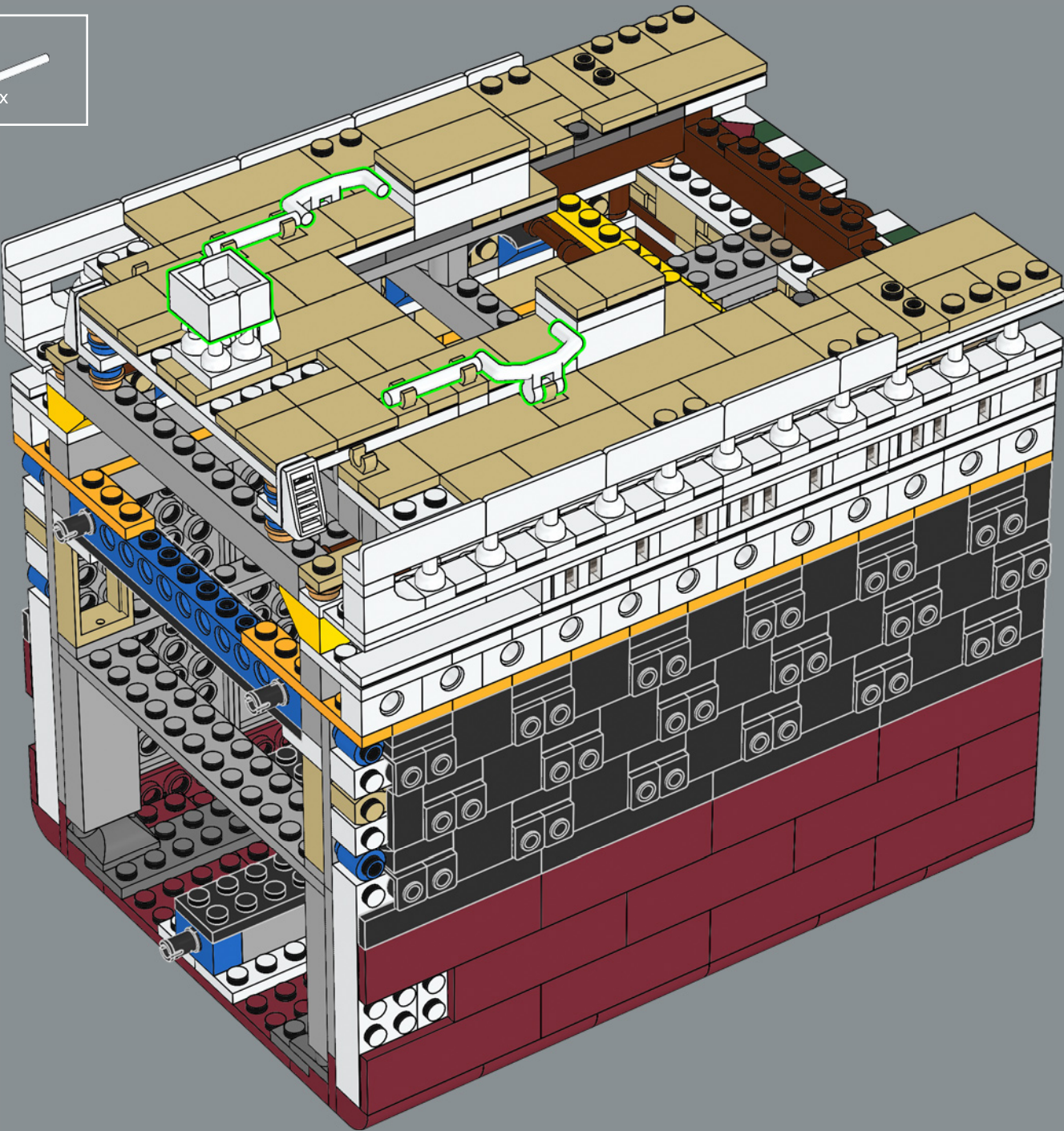



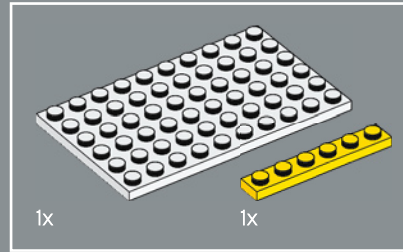
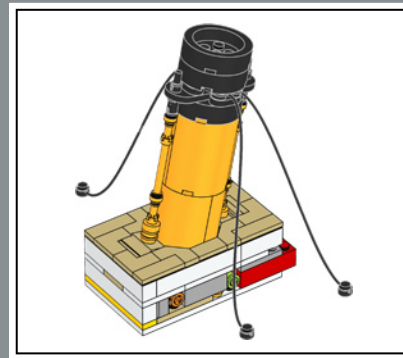
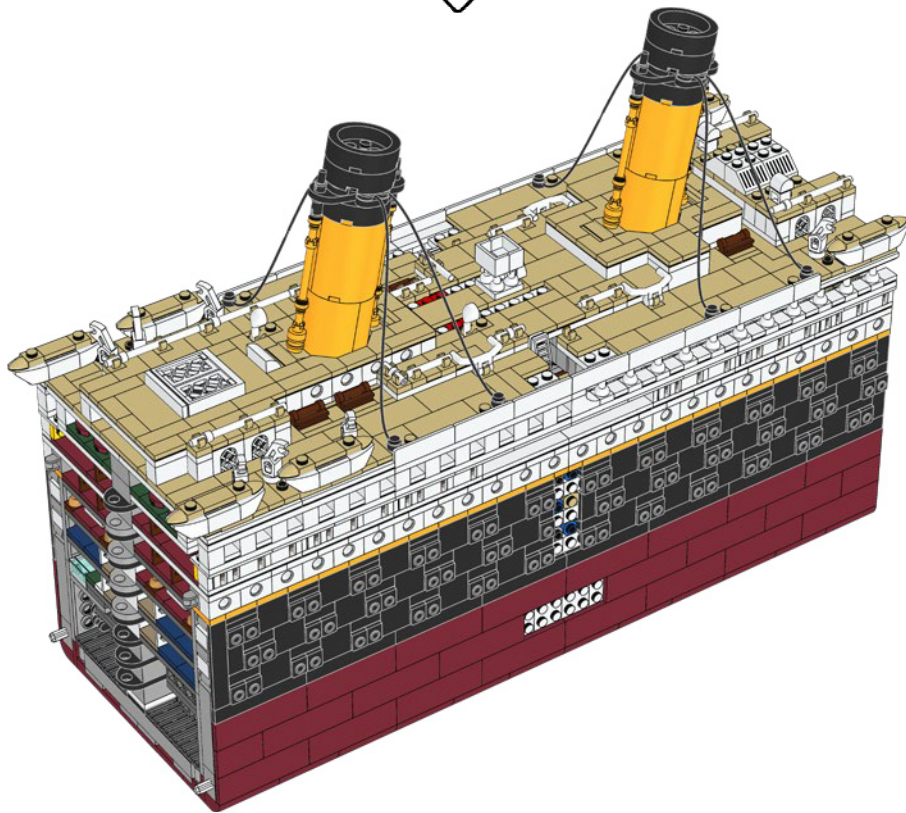
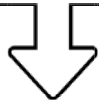

229

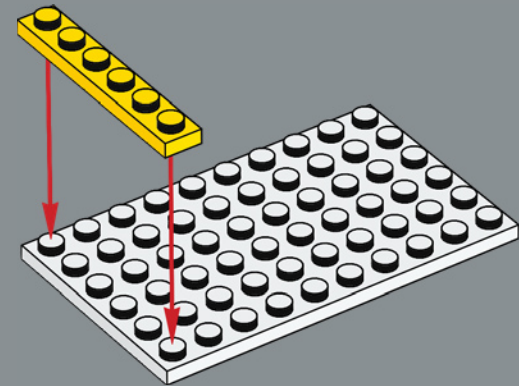

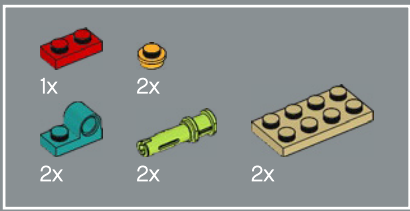

230

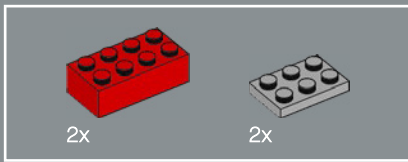
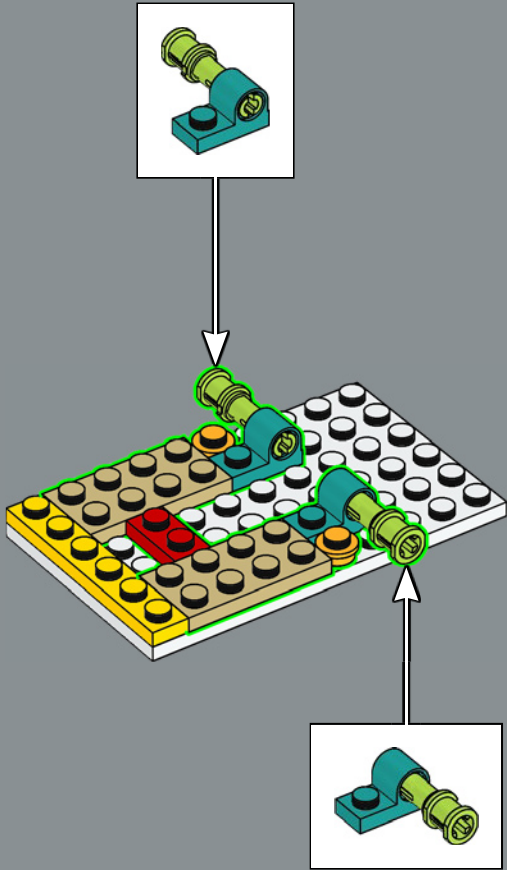

231

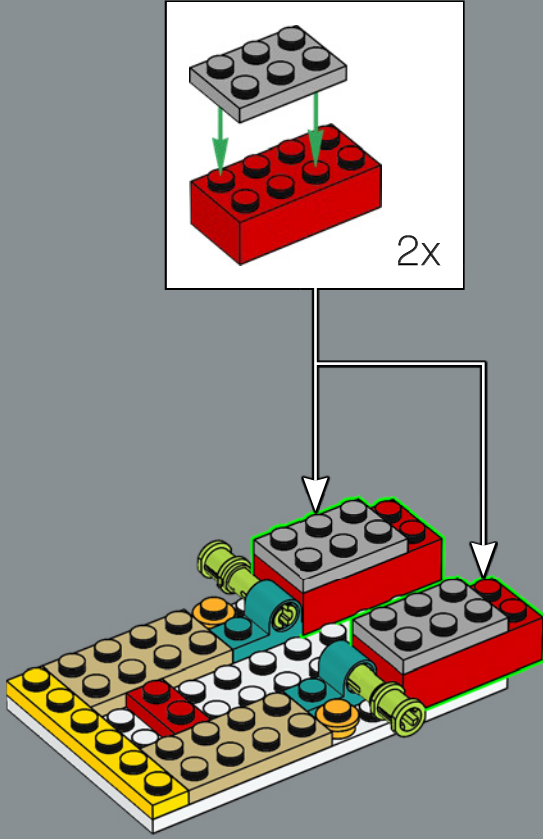

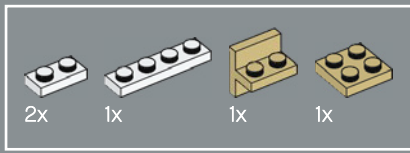

232

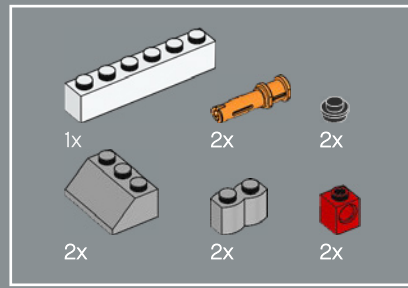
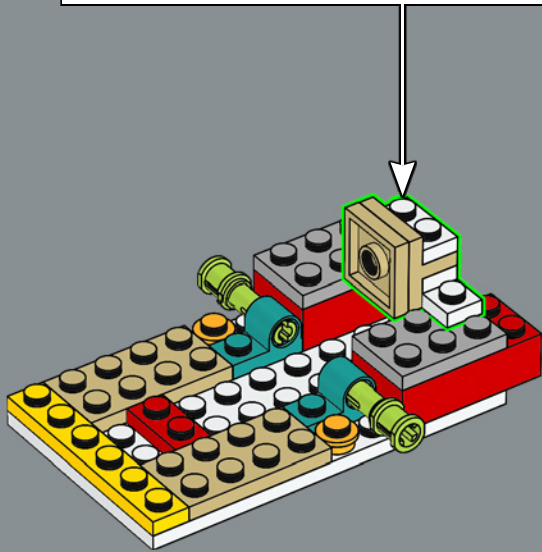
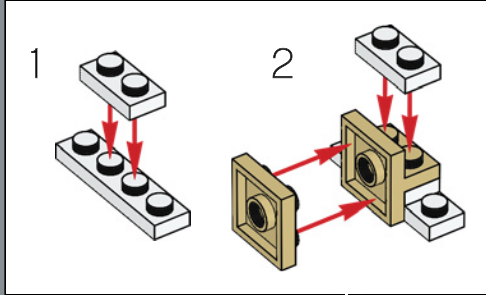

233

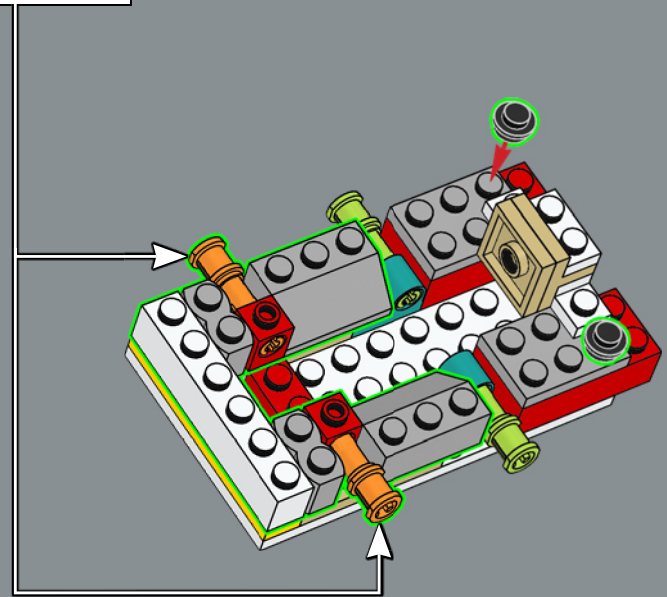
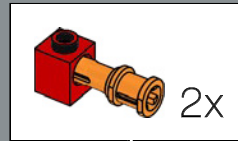

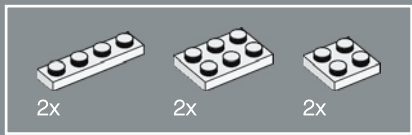

234

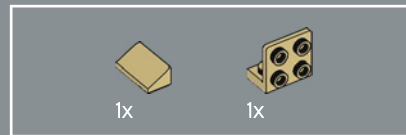
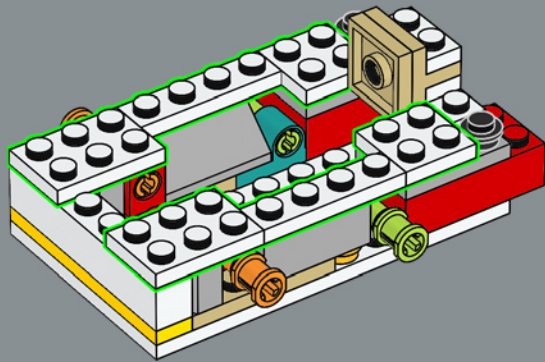

235

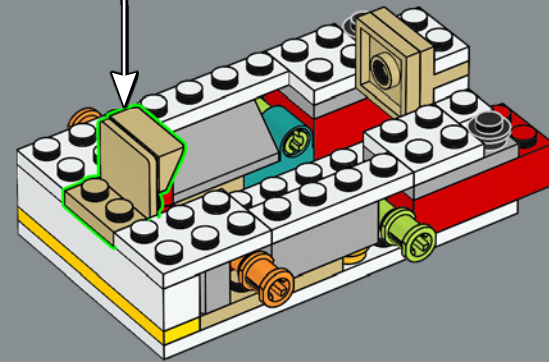
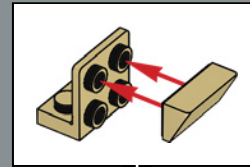

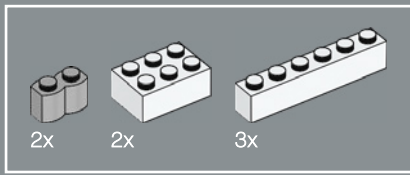

236

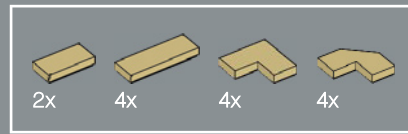
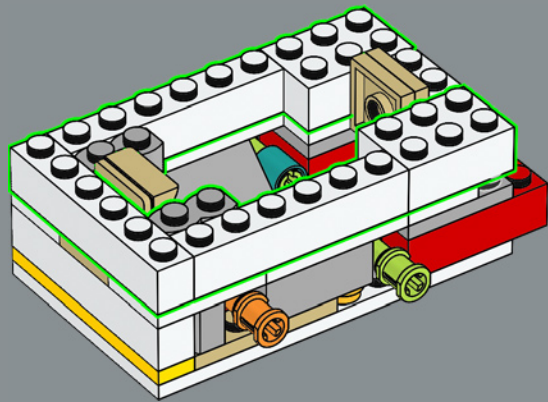

237

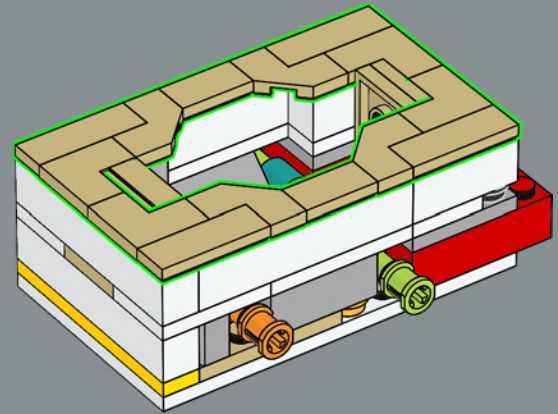

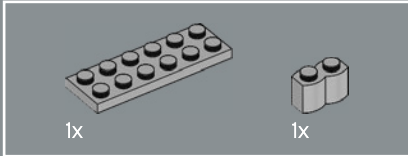
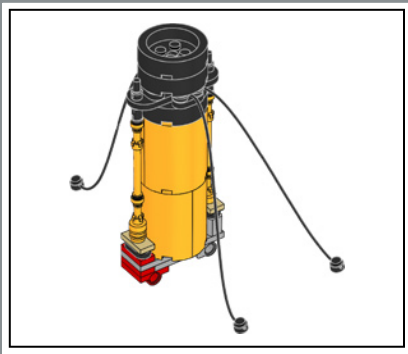

238

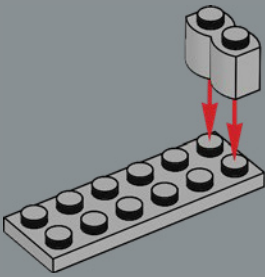

239

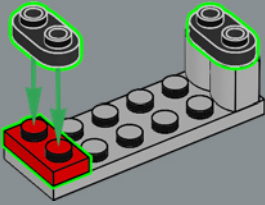

240

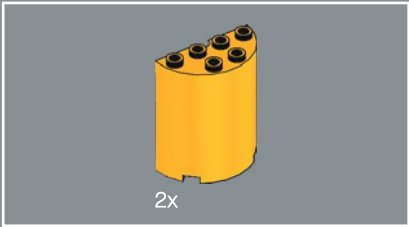
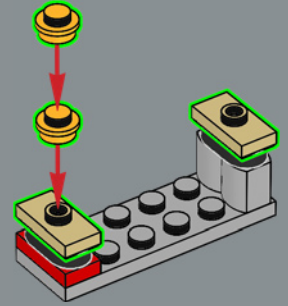

241

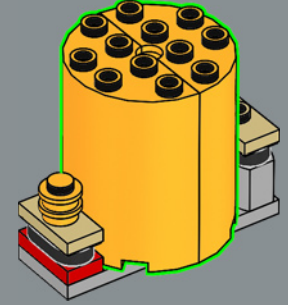

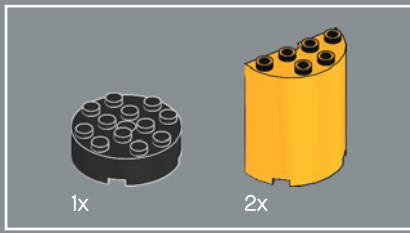

242

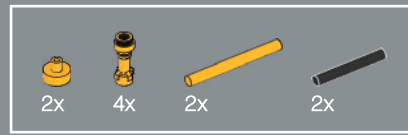
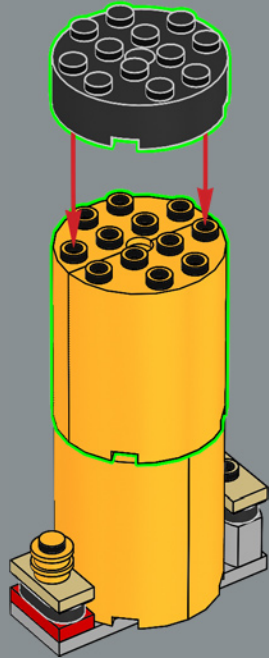

243

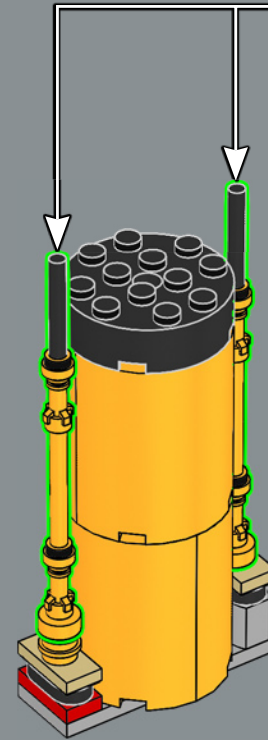
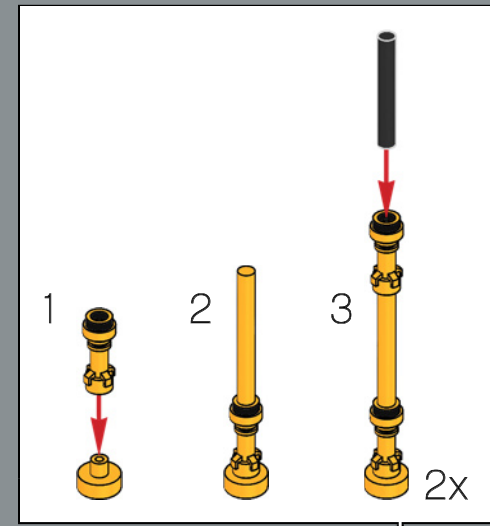

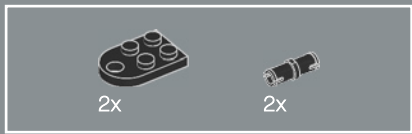

244

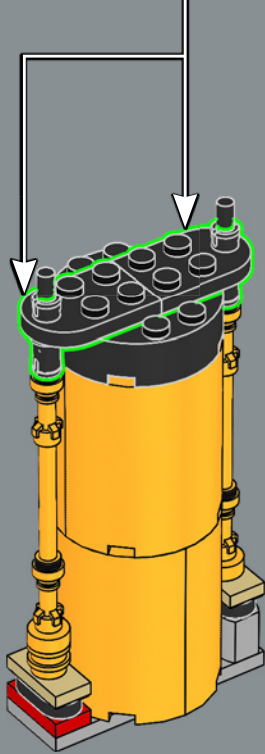
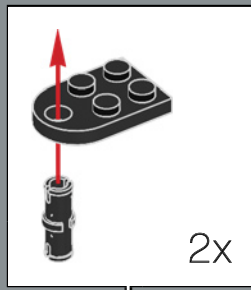

245

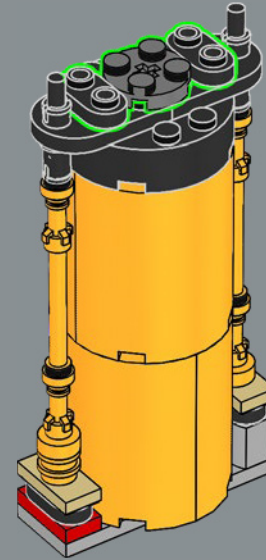



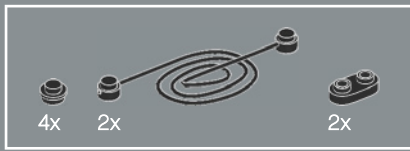

246

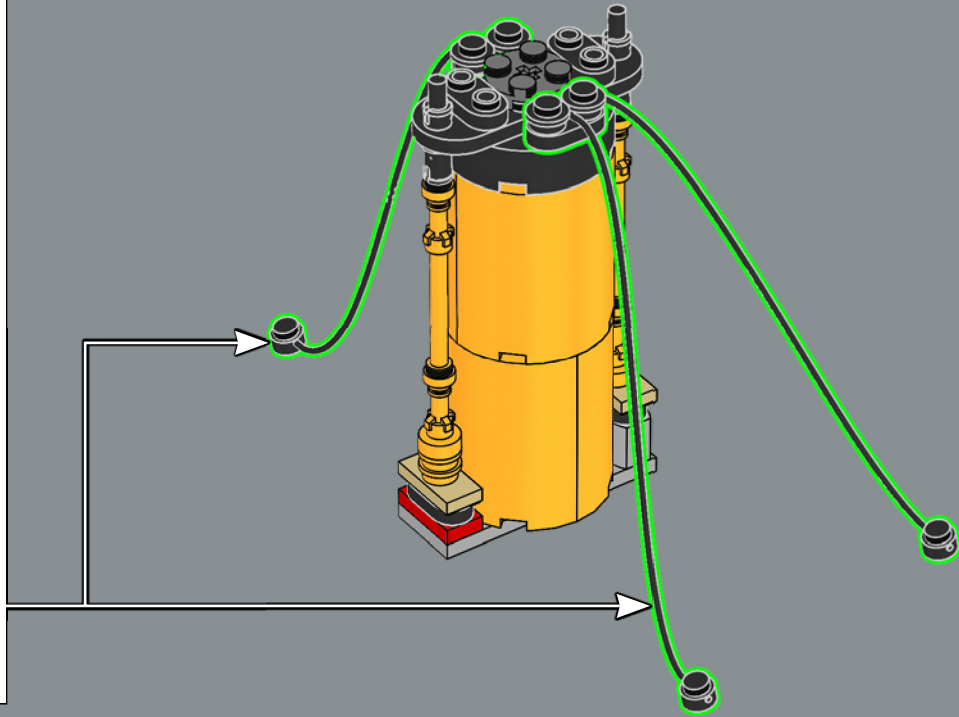
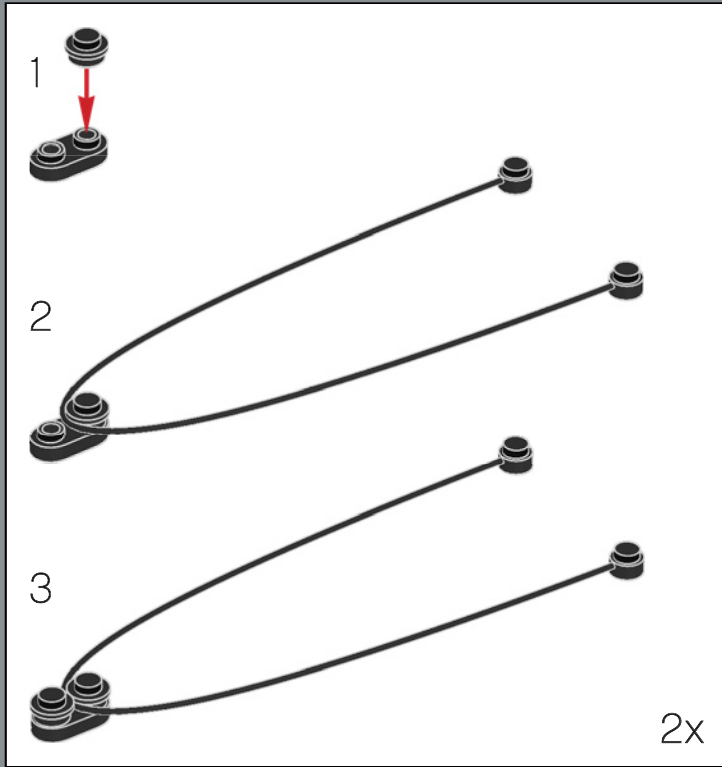

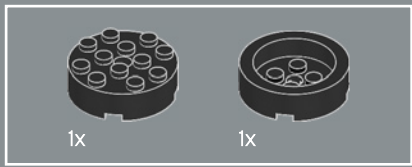

247

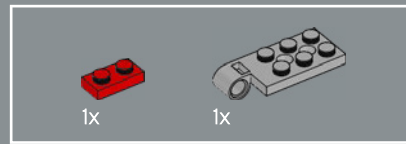
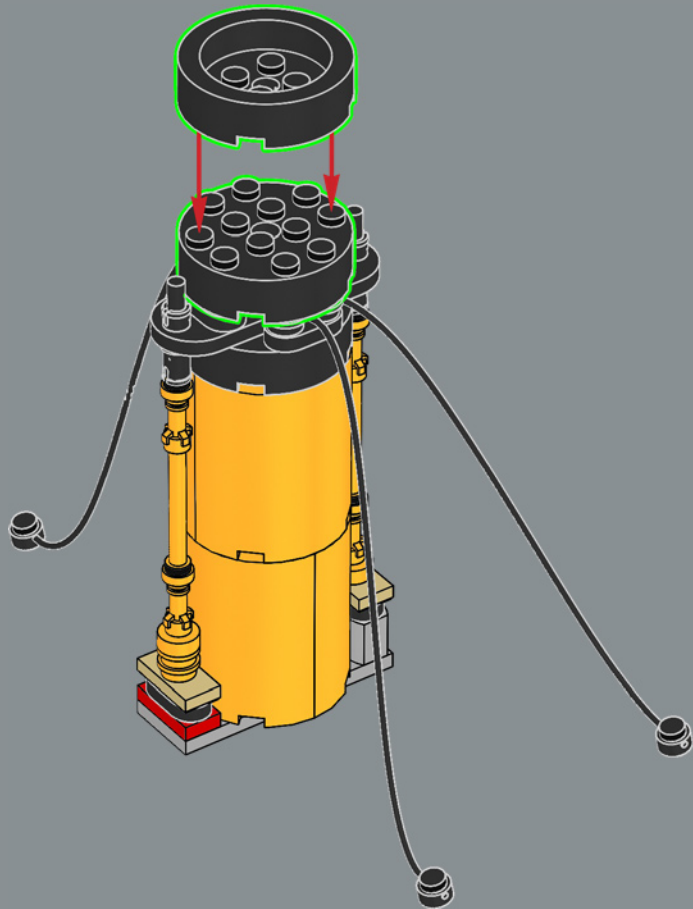

248

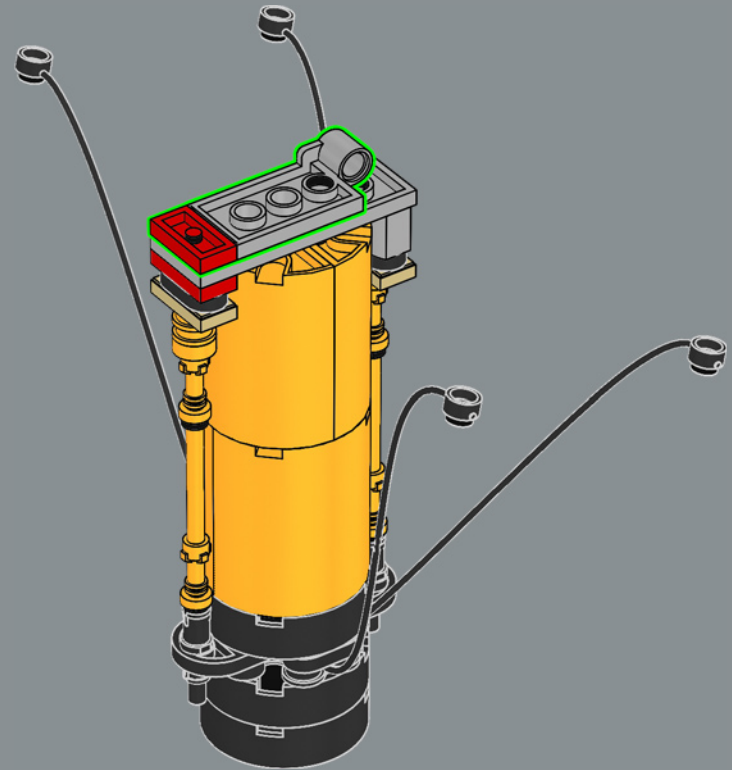

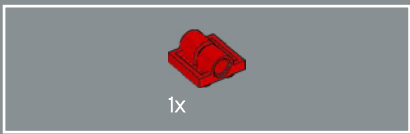

249

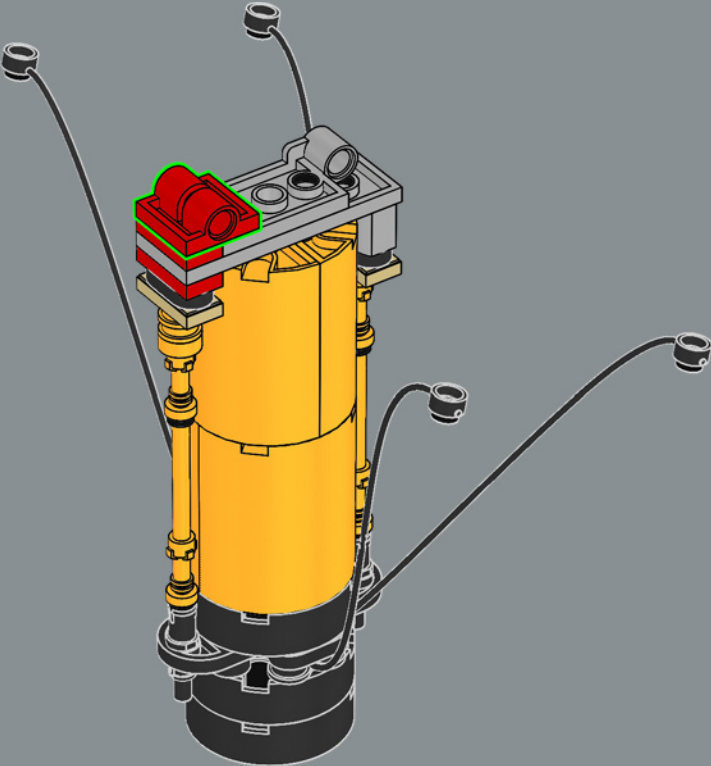

250

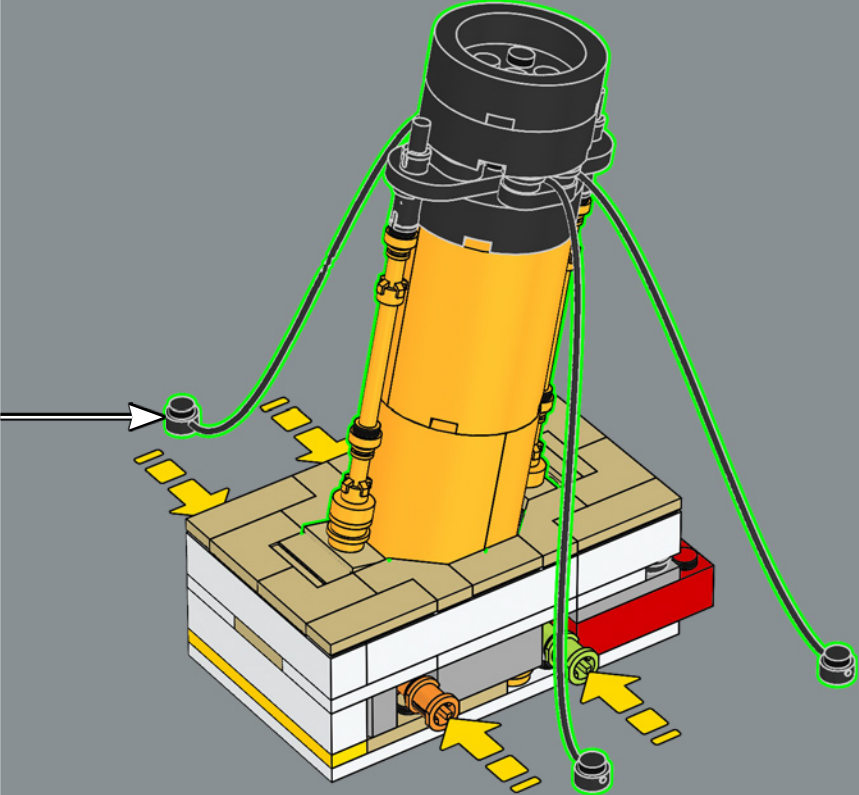

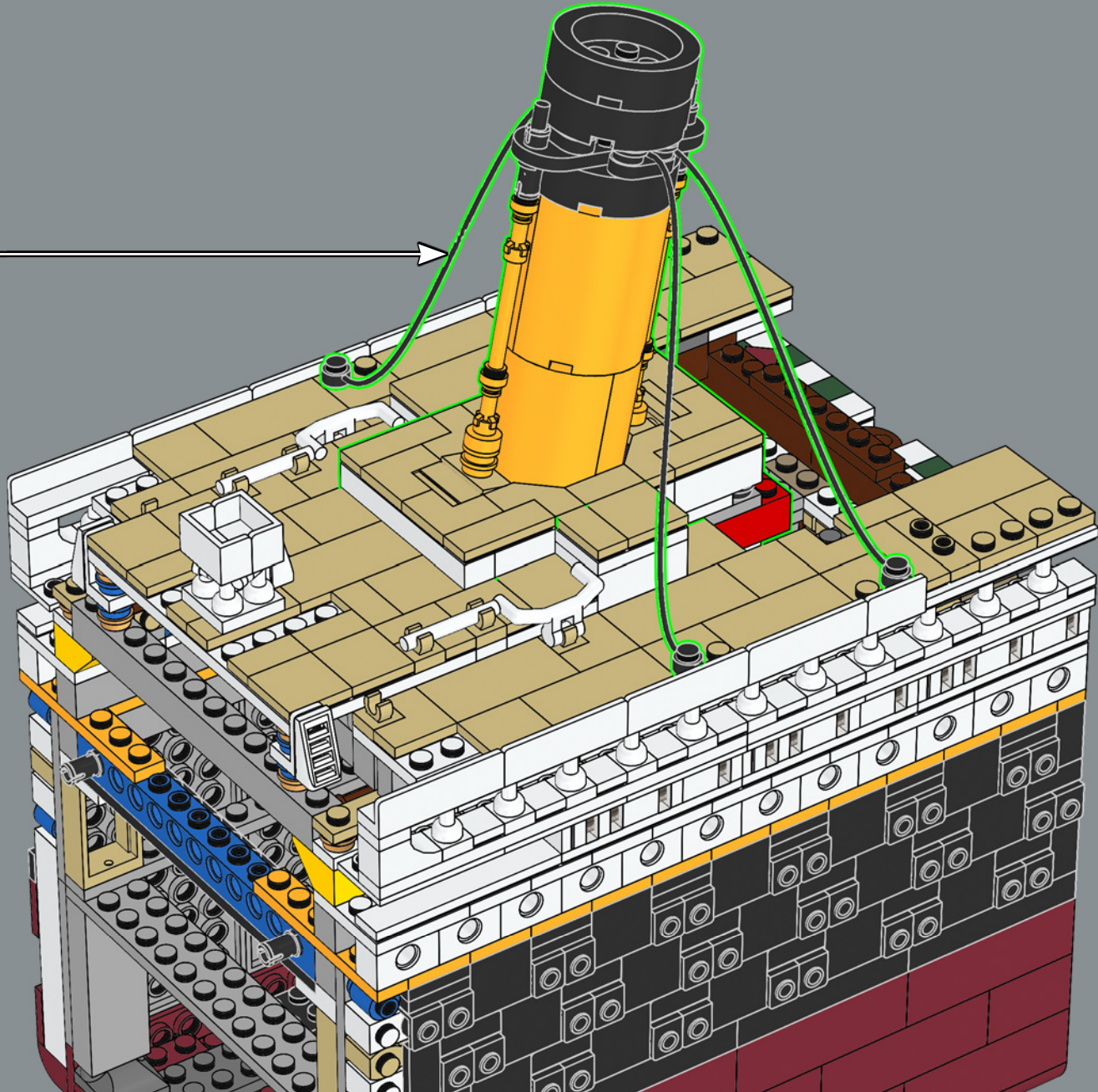

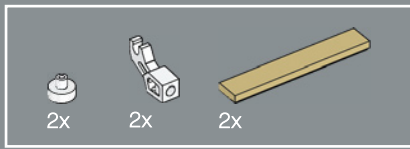

252

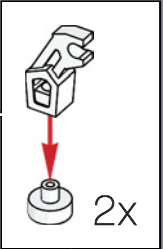
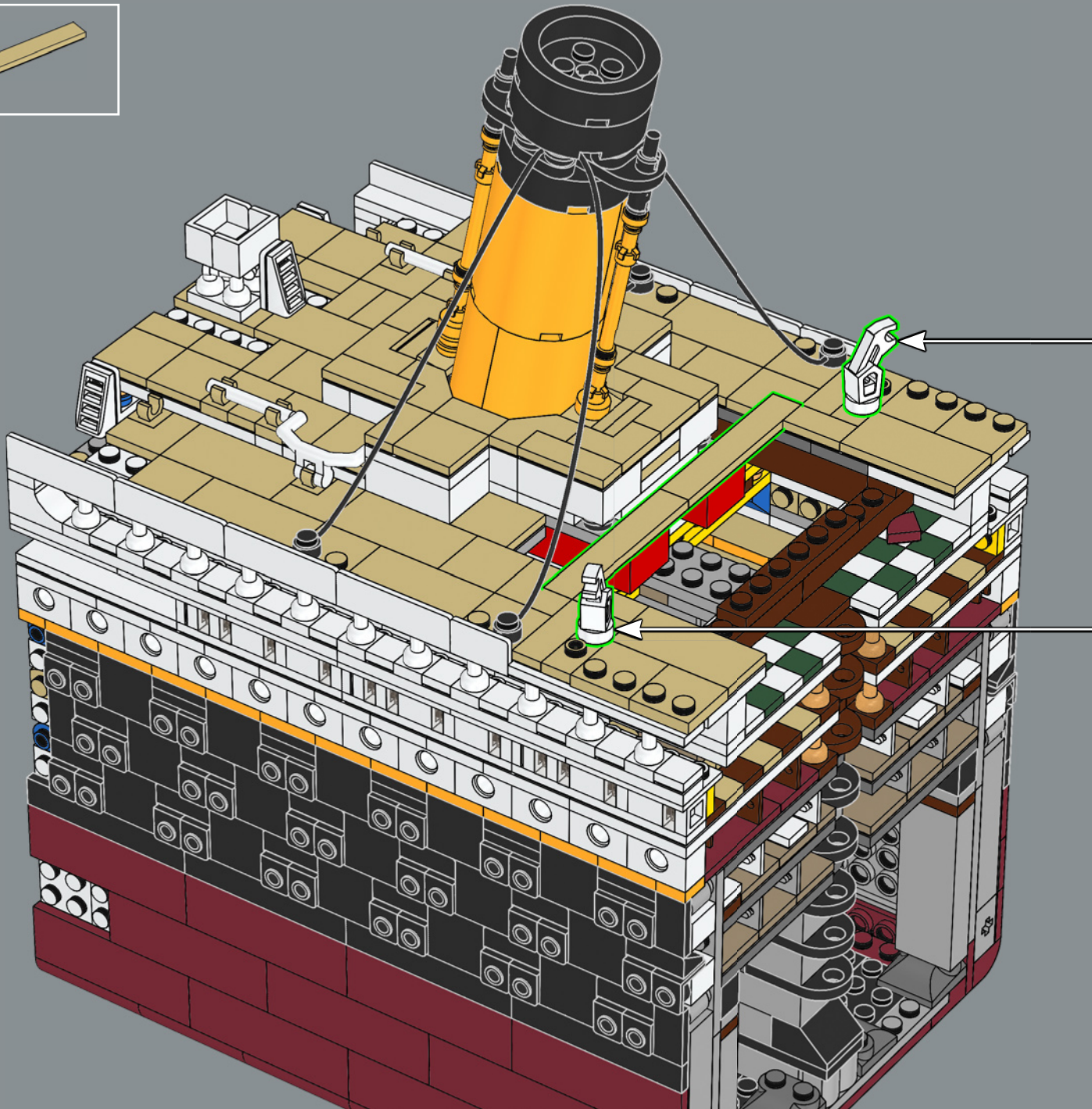

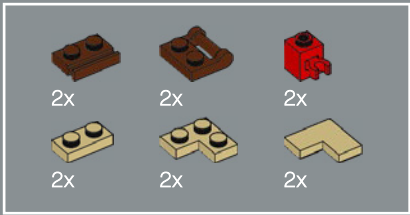

253

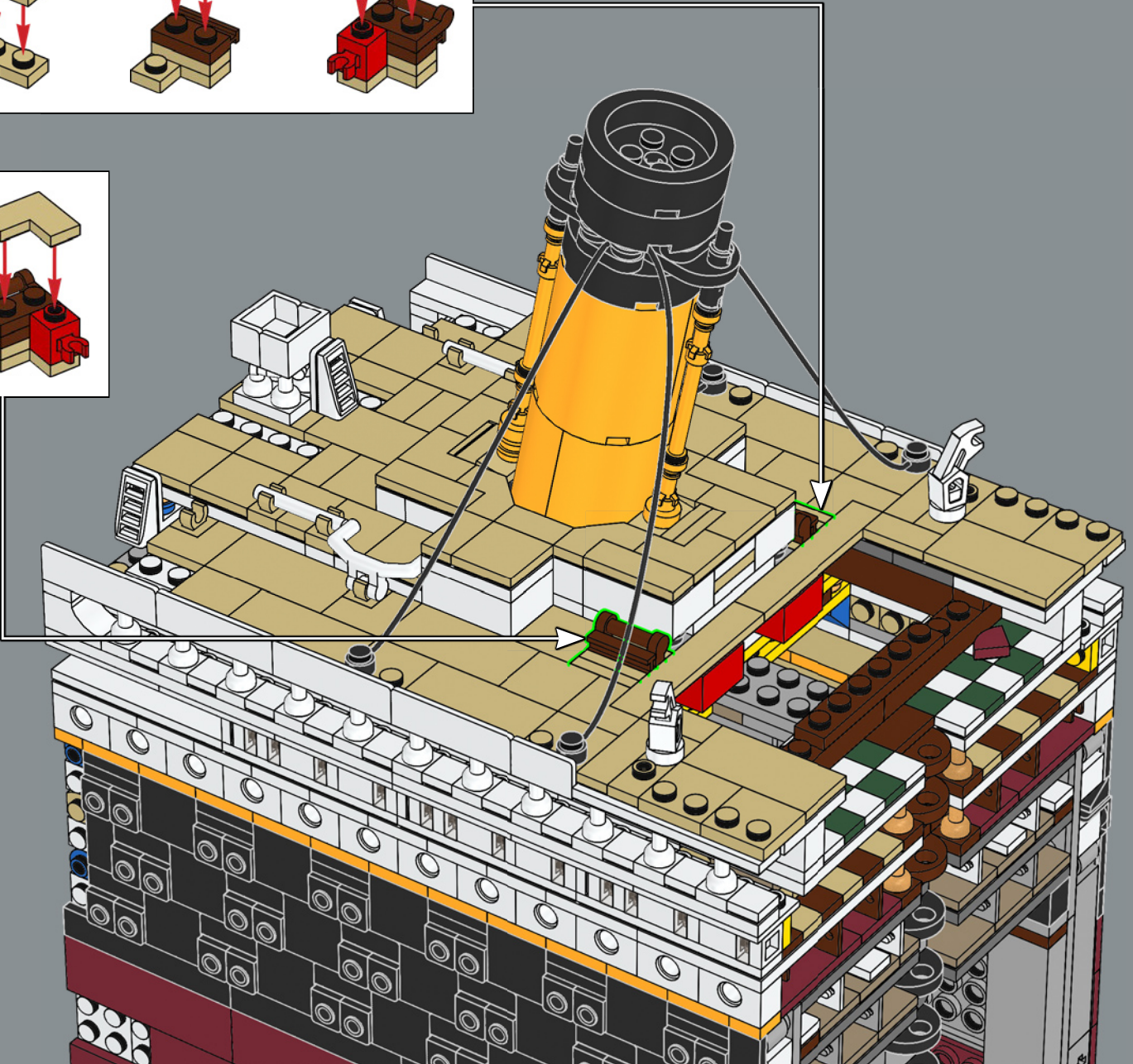
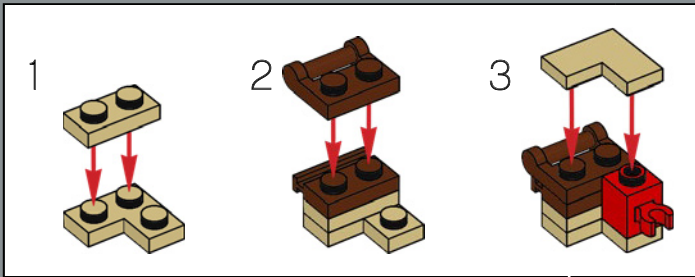
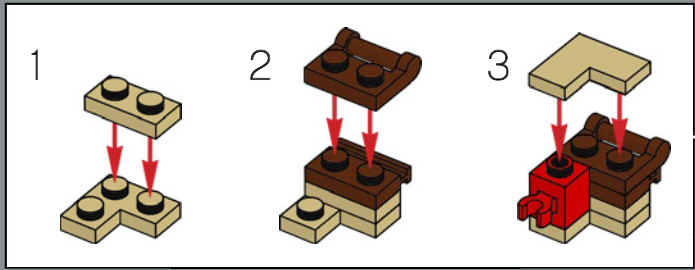

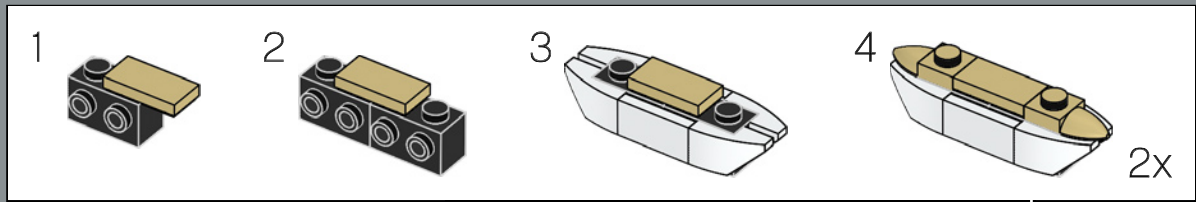
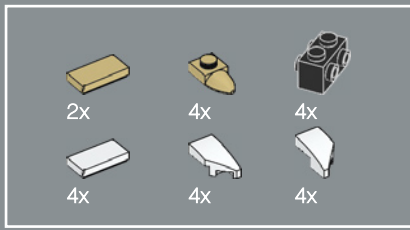

254

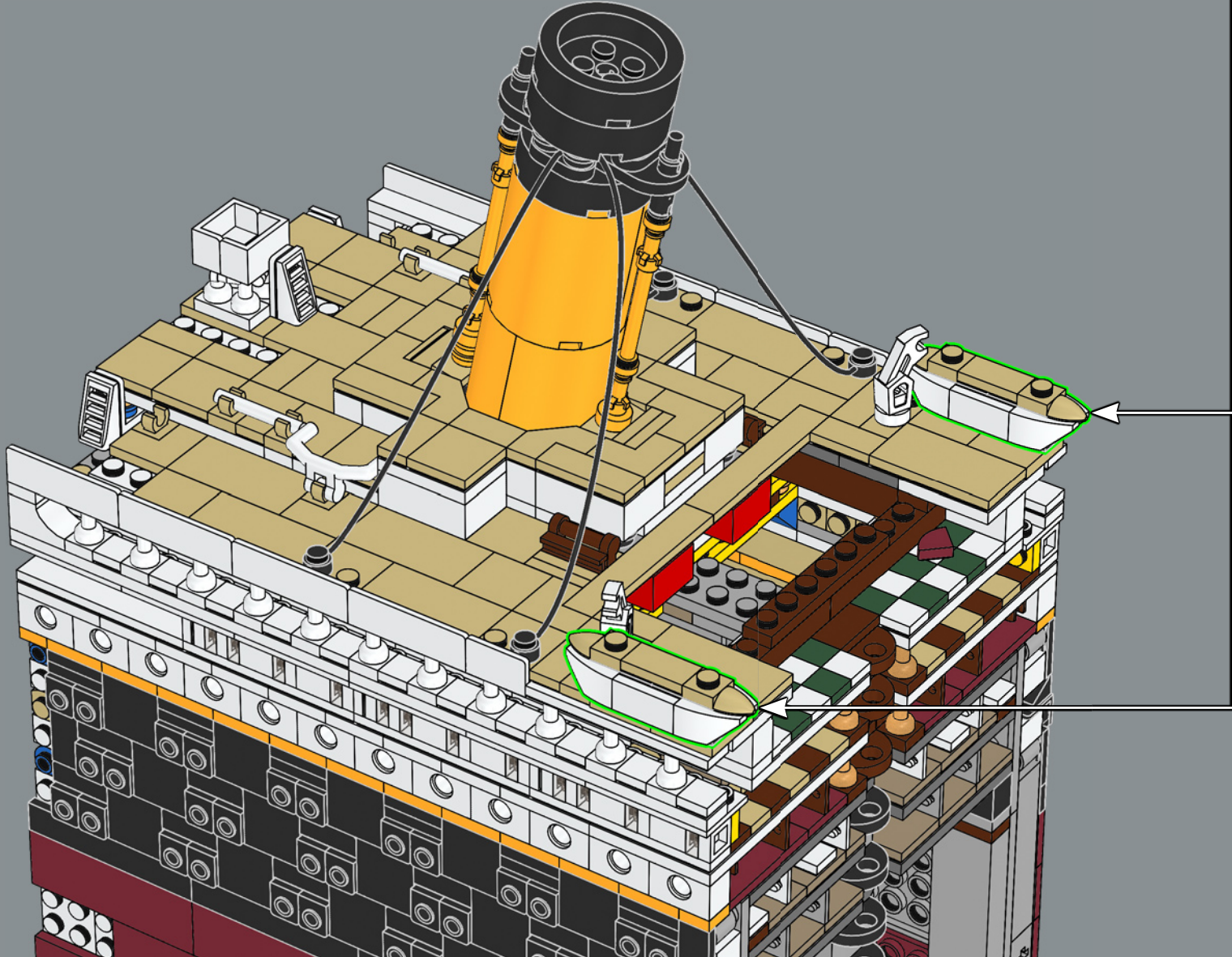

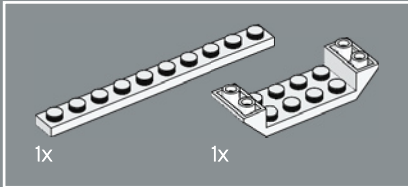
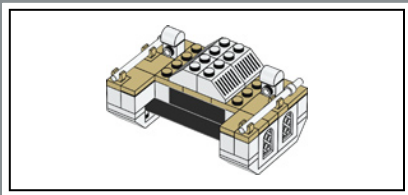

255

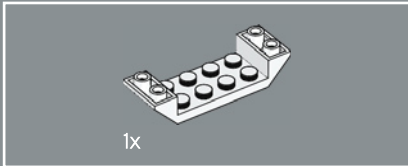
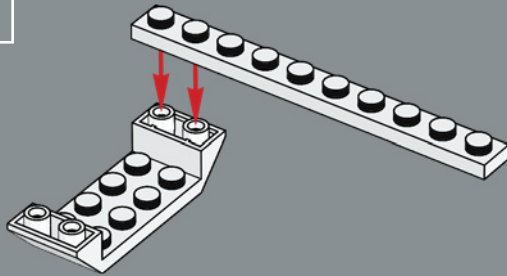

256

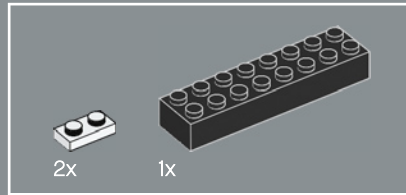
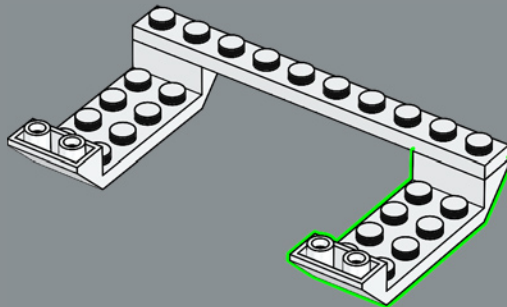

257

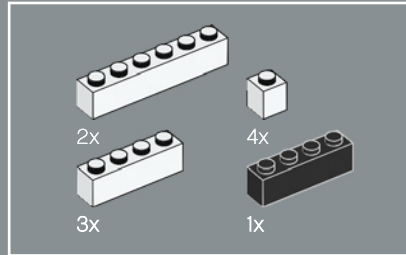
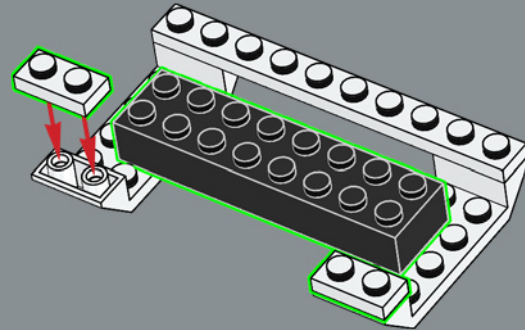

258

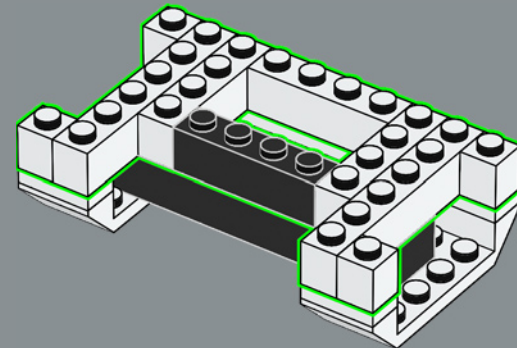



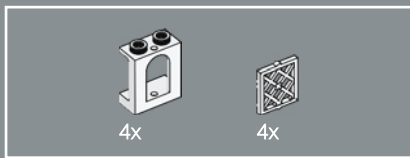

259

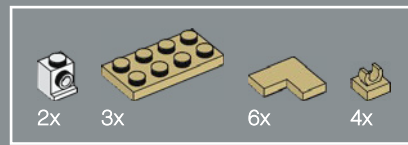
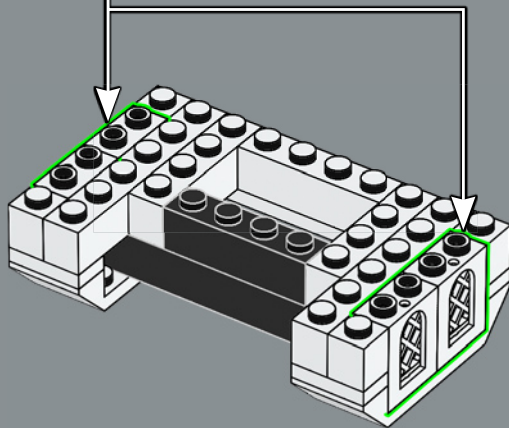
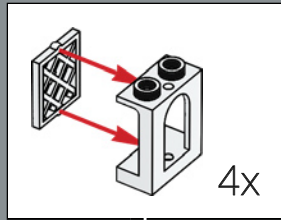

260

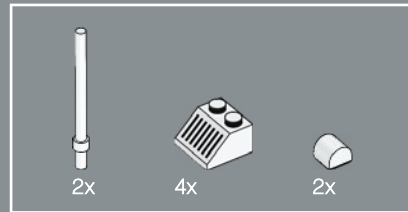
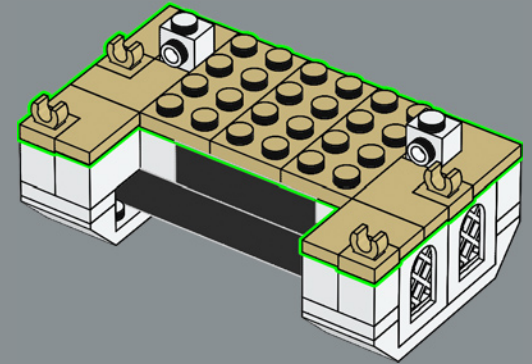

261

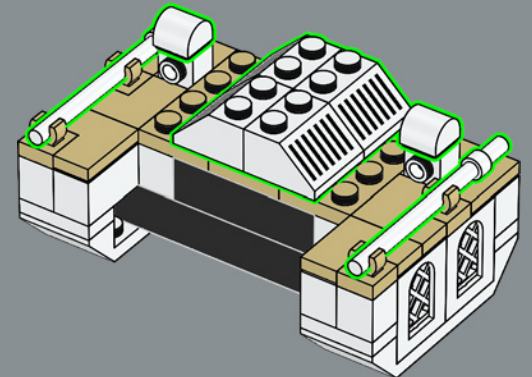

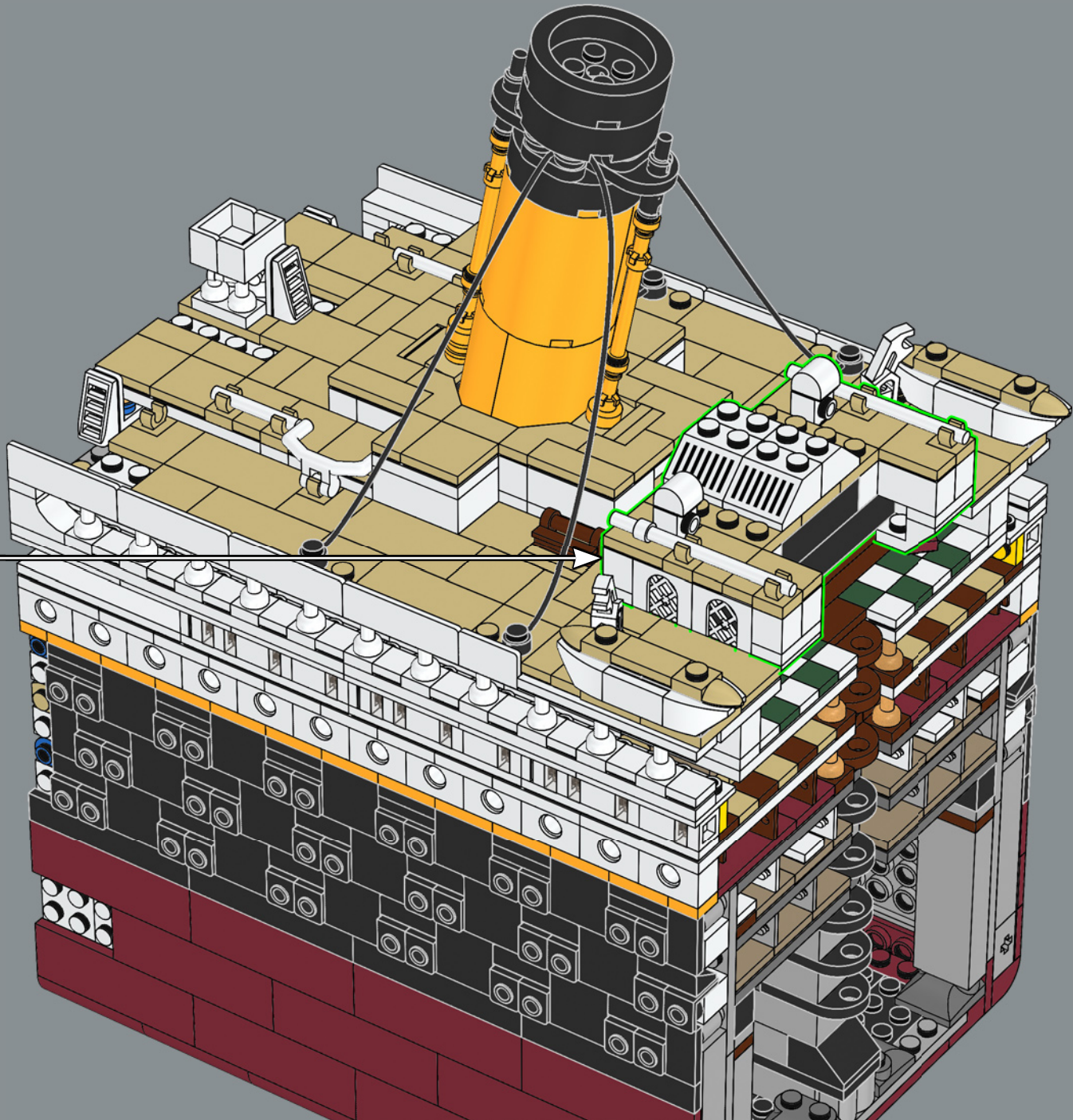

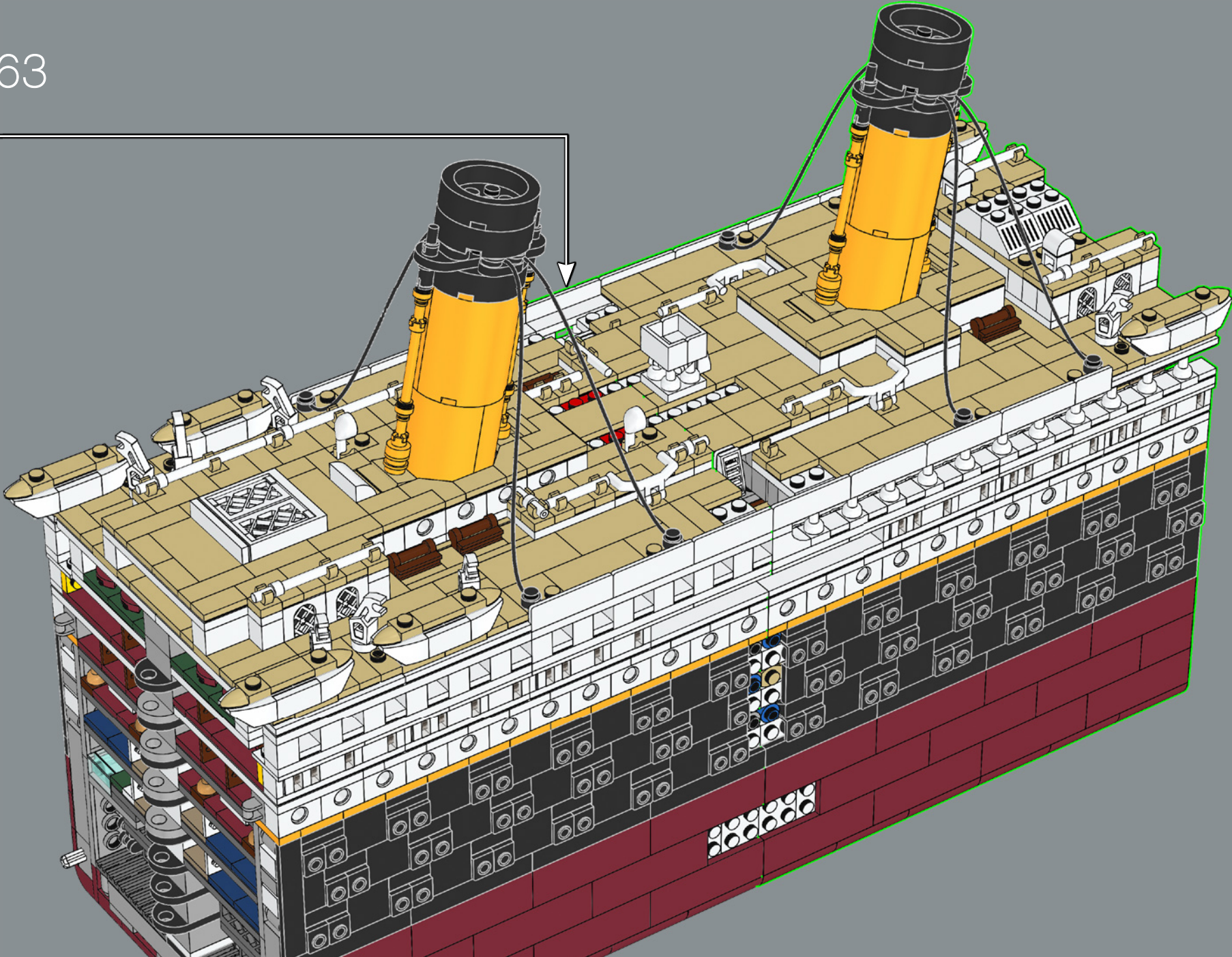

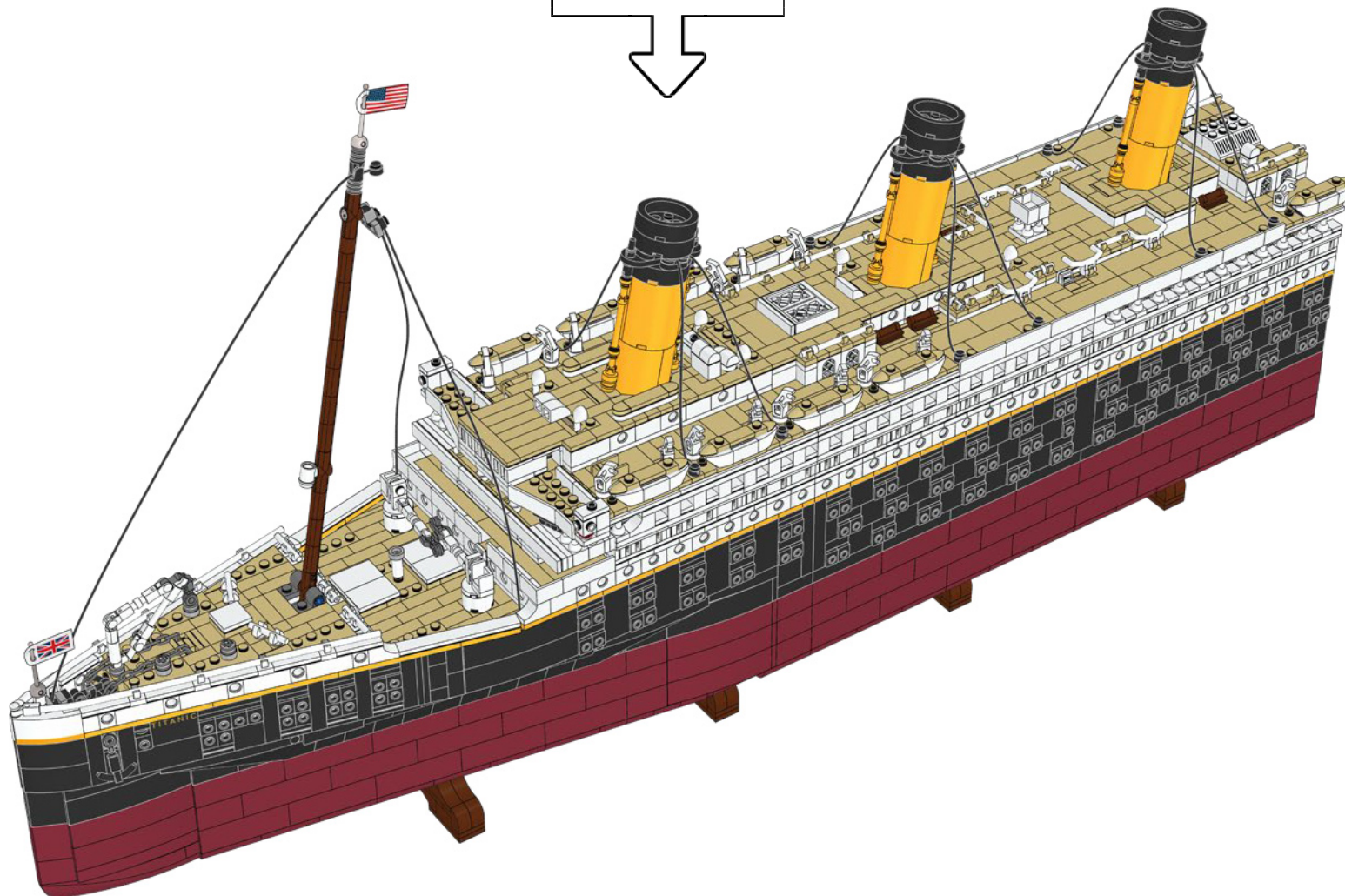

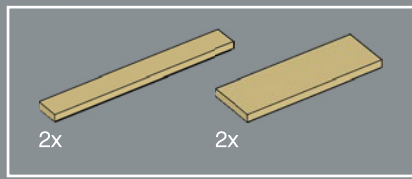

264

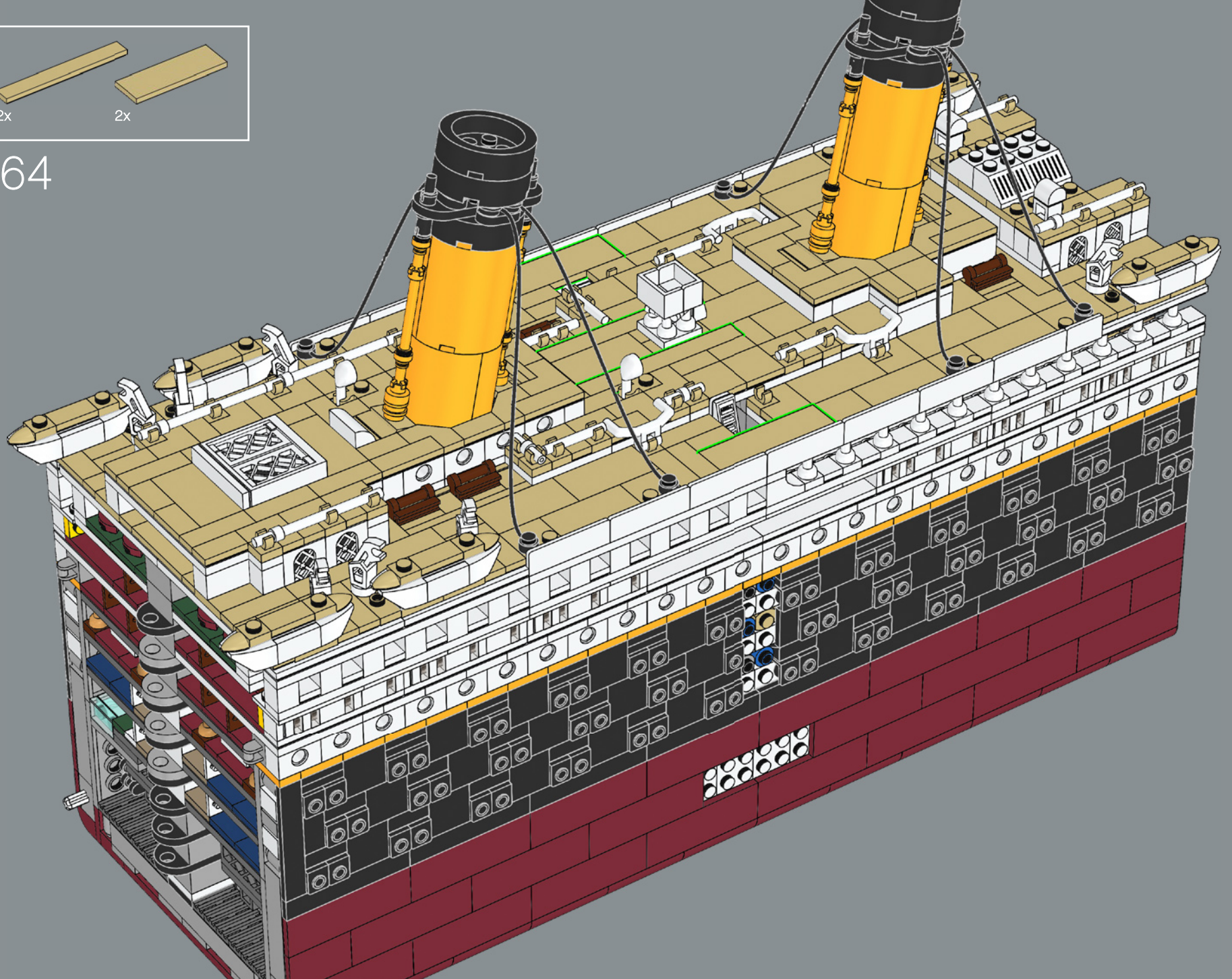

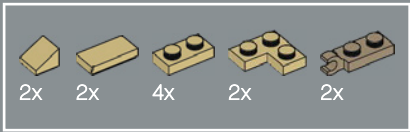

265

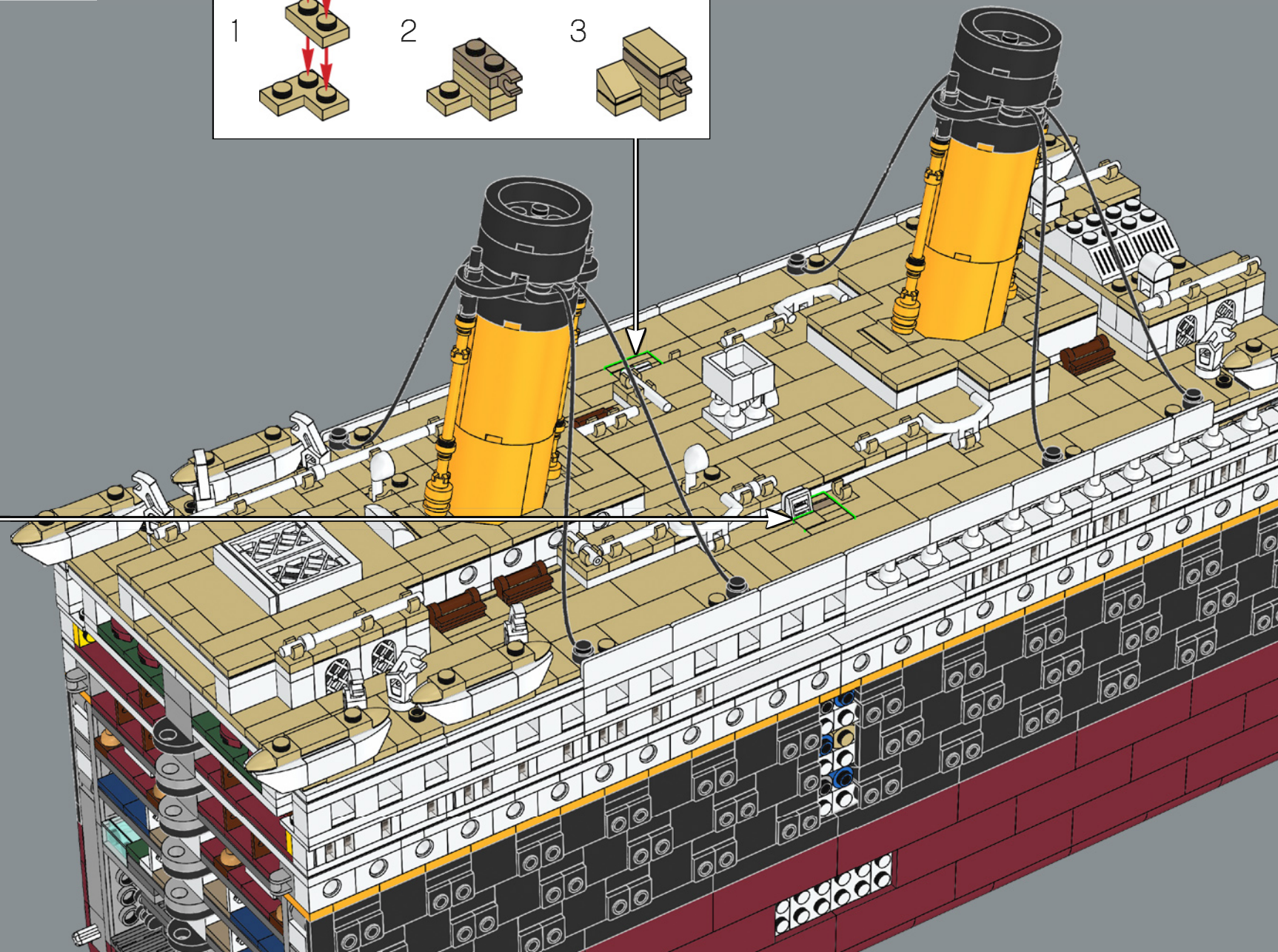
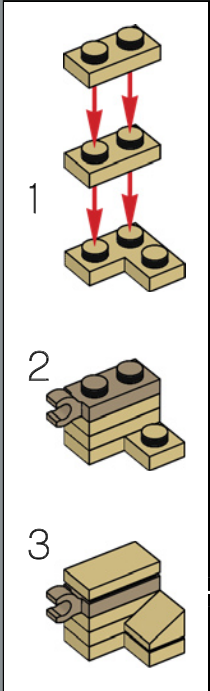
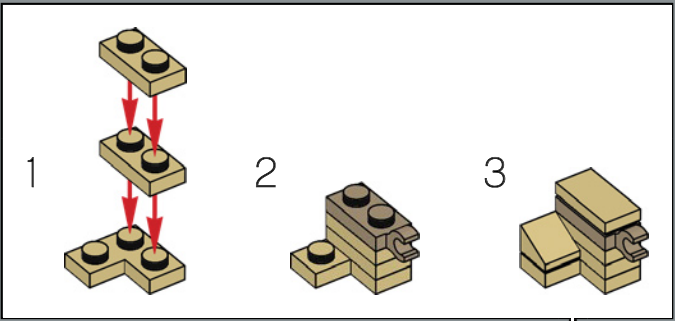

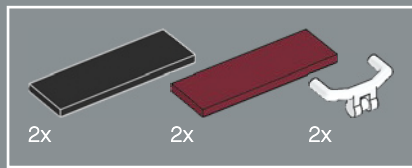

266

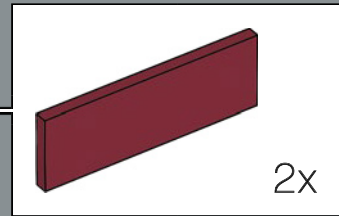
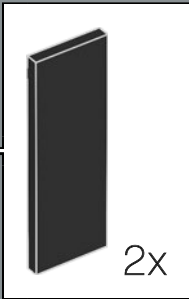
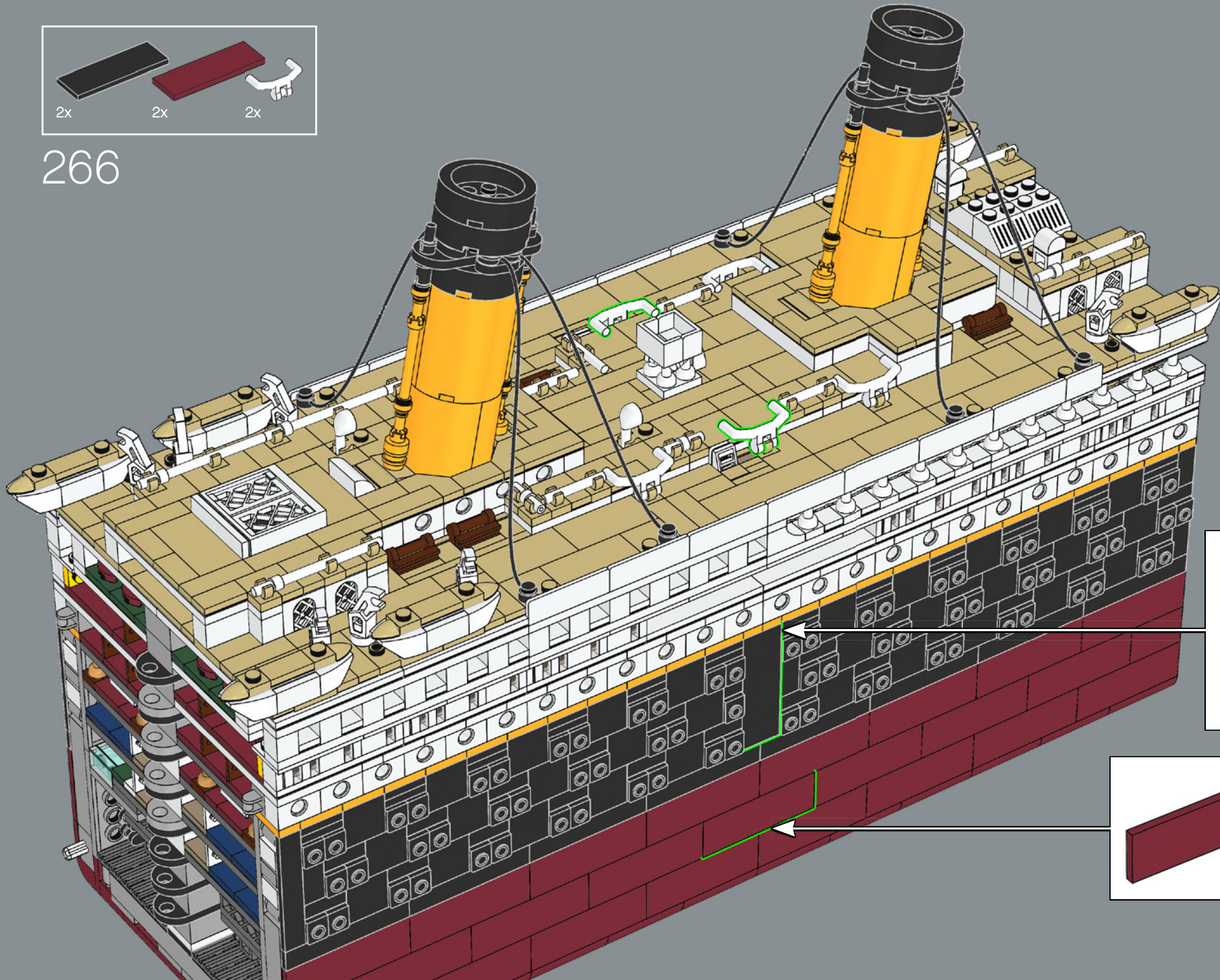

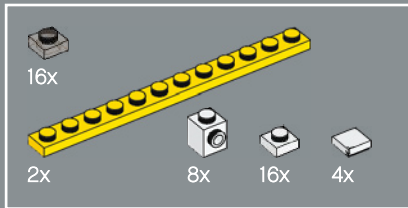
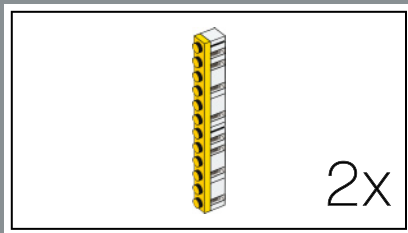

267

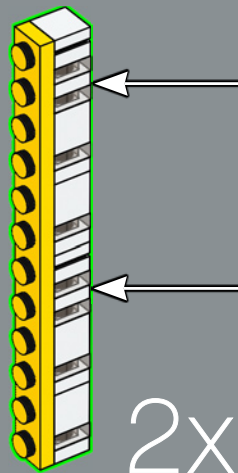
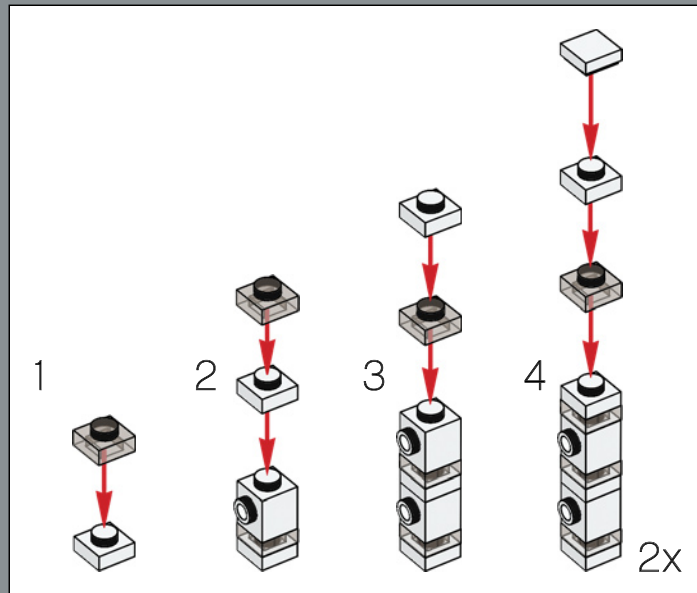



268

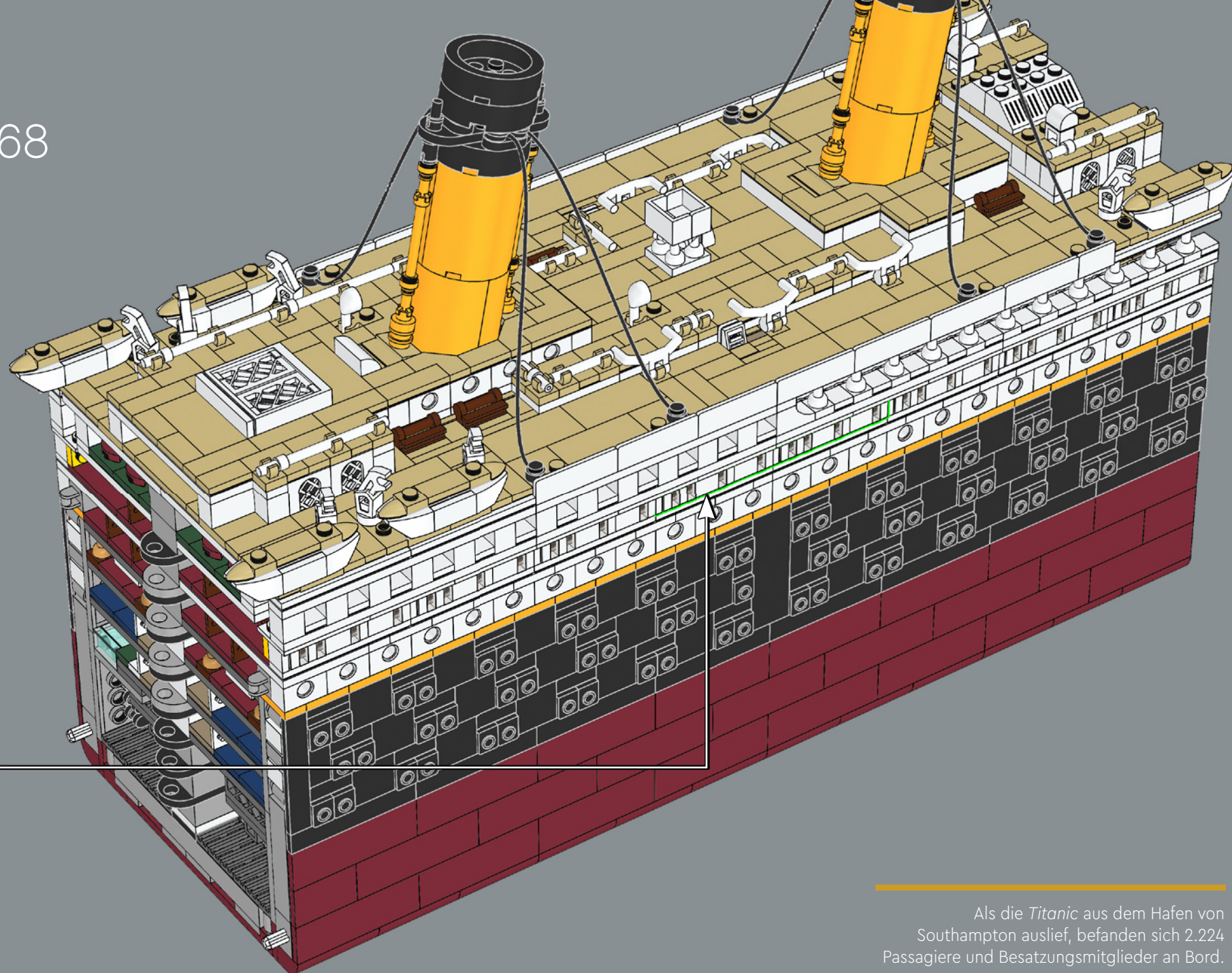

Als die *Titanic* aus dem Hafen von Southampton auslief, befanden sich 2.224 Passagiere und Besatzungsmitglieder an Bord. 209

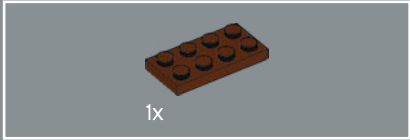
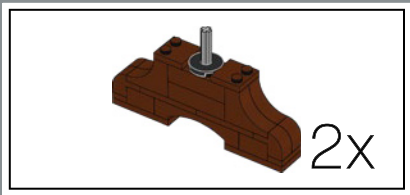

269

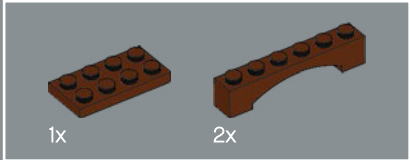
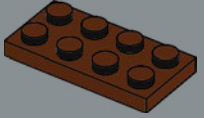

270

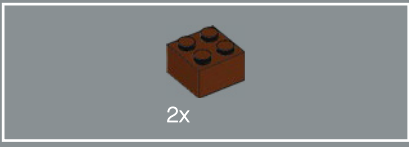
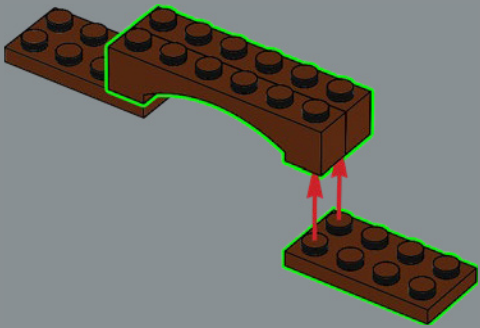

271

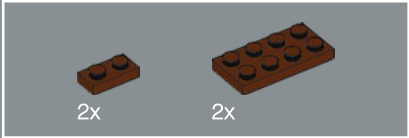
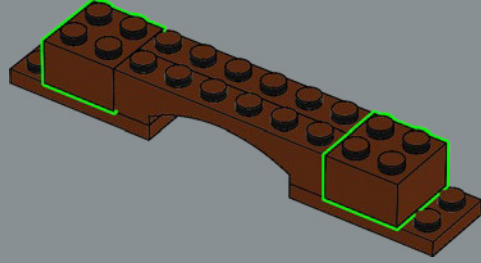

272

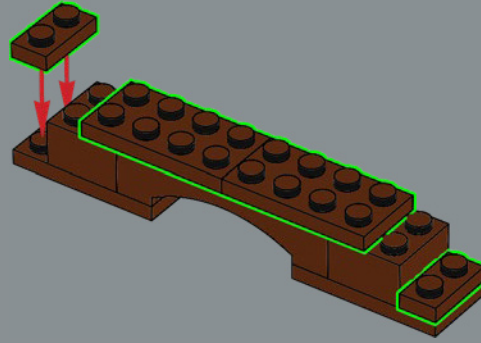



273

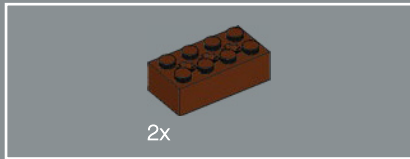
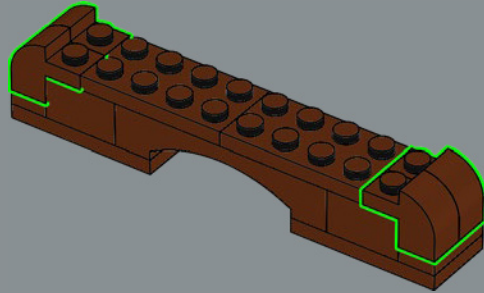

274

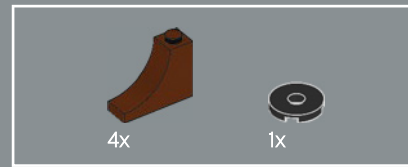
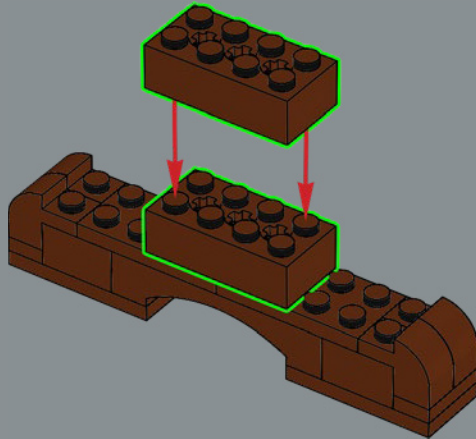

275

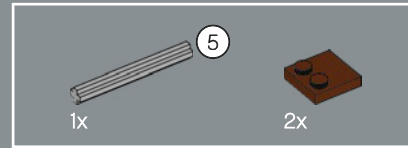
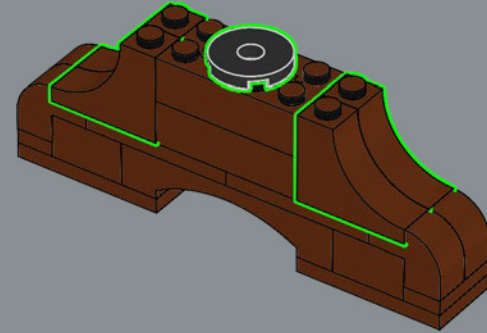

276

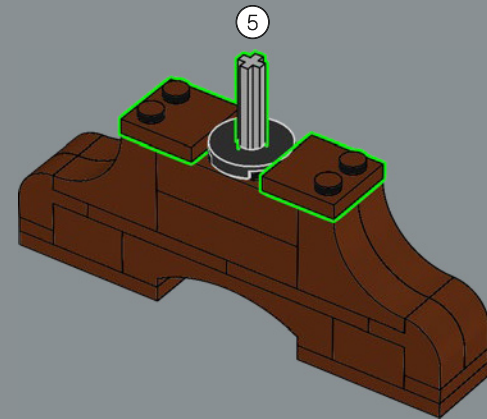

2x



277

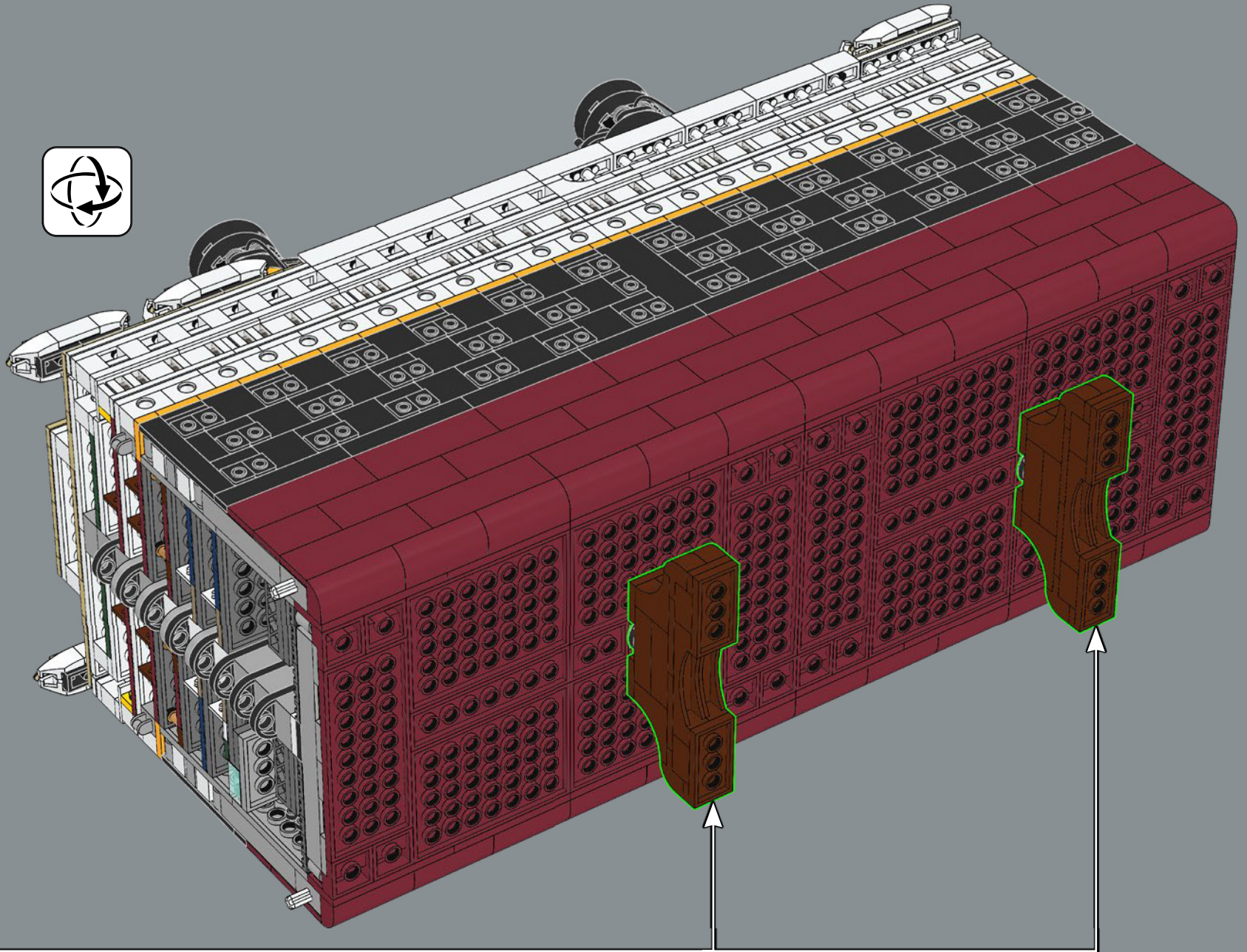

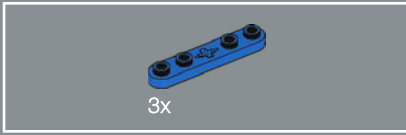
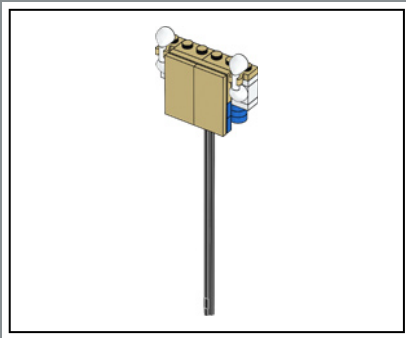

3x

278

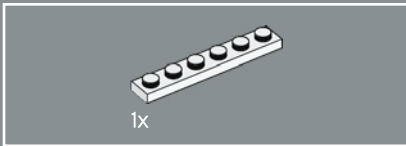
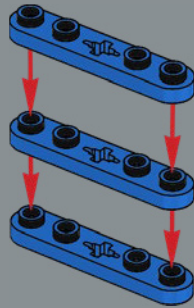

1x

279

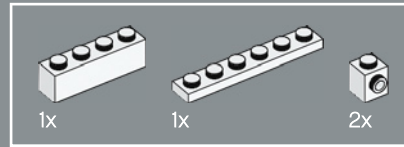
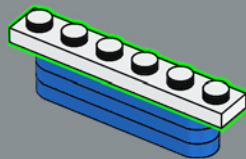

1x

1x

2x

280

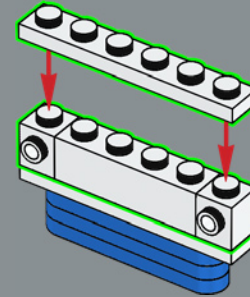

2x

2x

2x

281

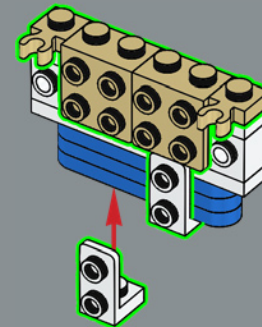

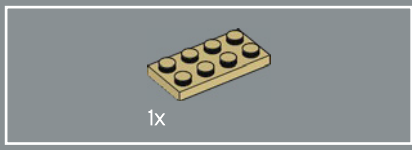

282

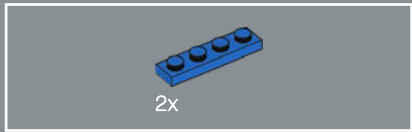
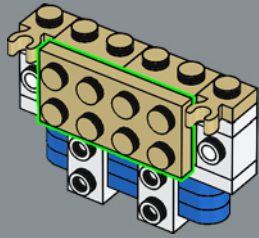

283

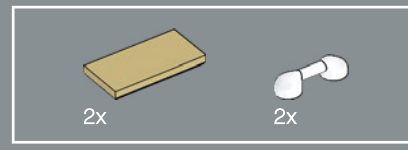
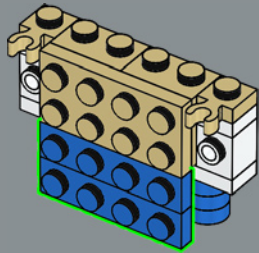

284

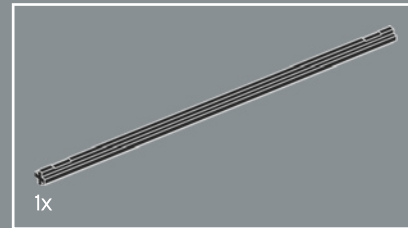
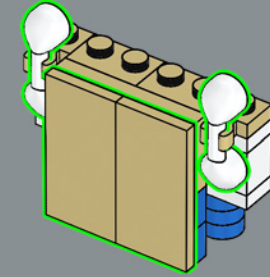

285

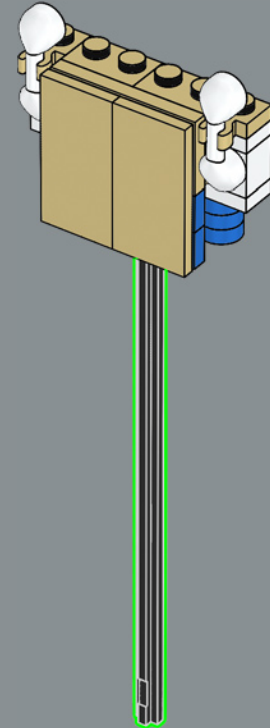

286

