

BIONICLE

www.bionicle.com



8622
NIDHIKI



BIONICLE

METRU NUI





1

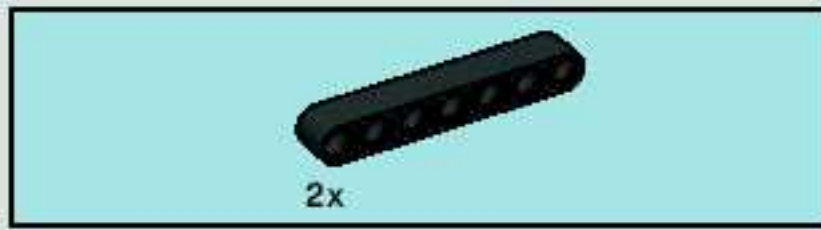
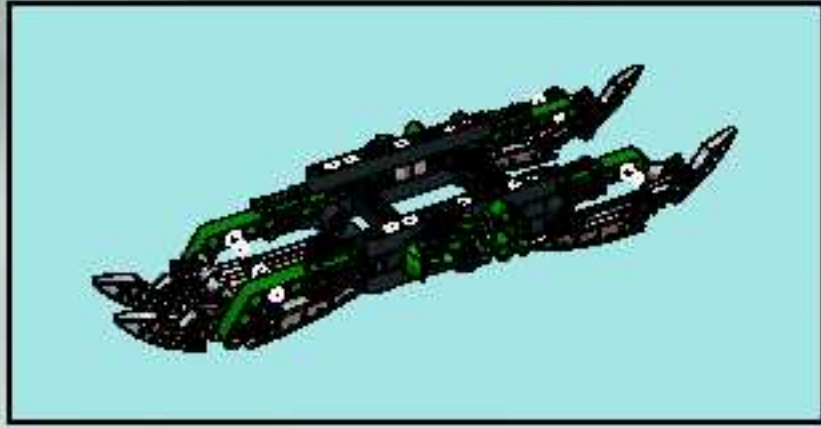
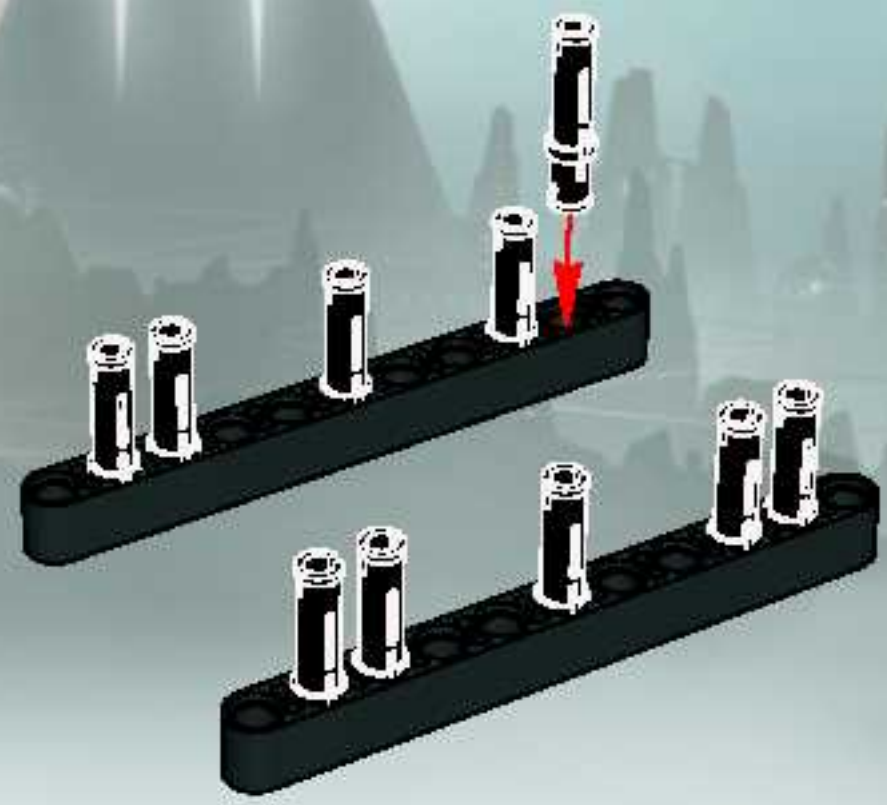

2

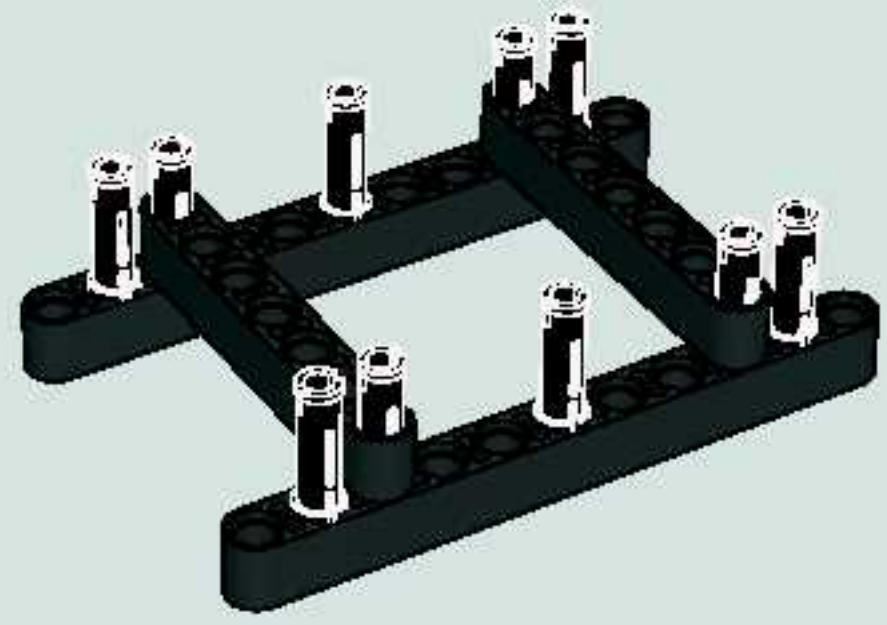

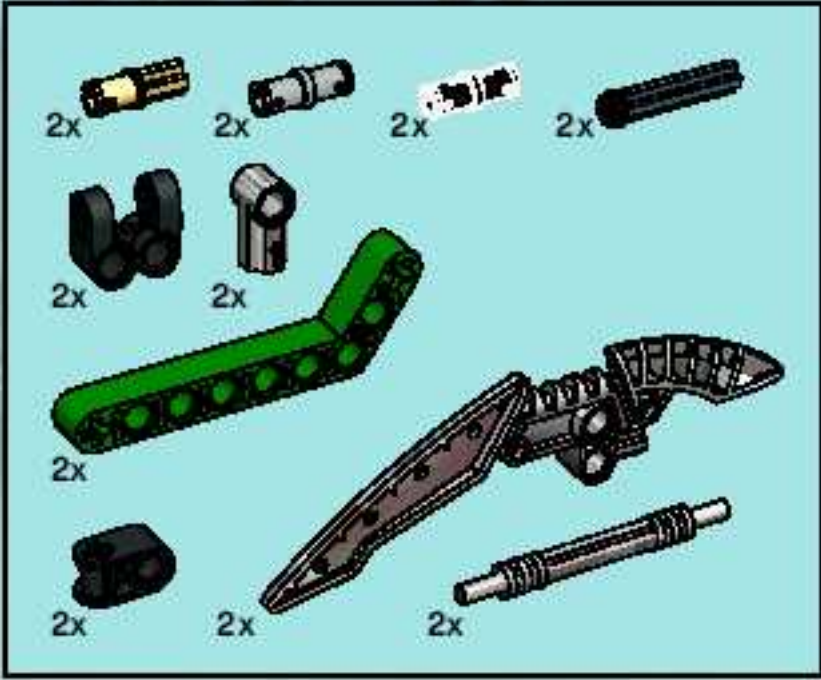
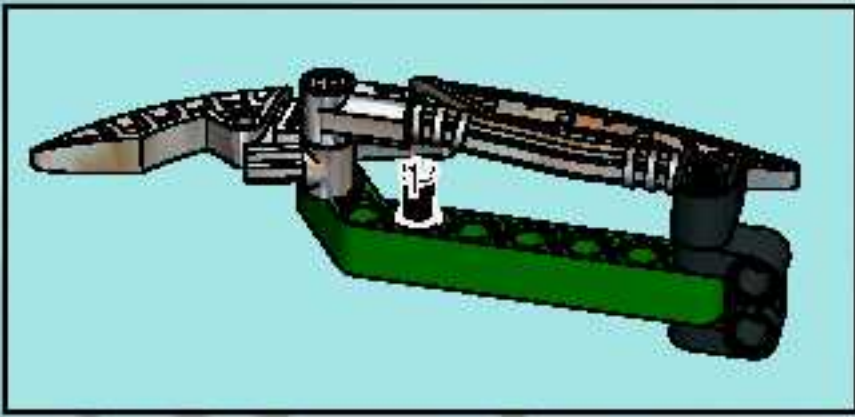

1

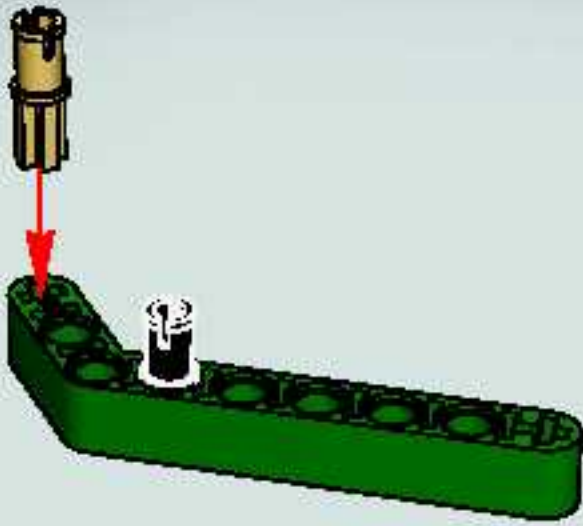

2

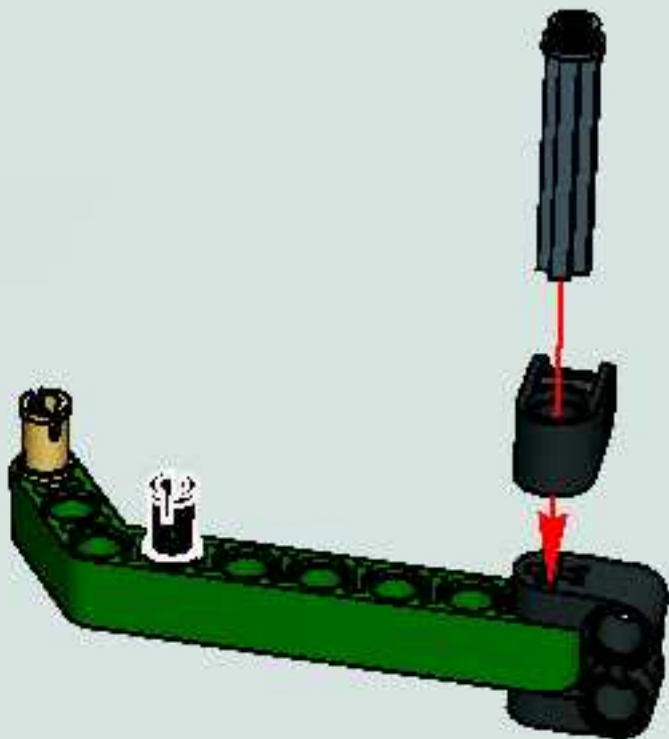

3

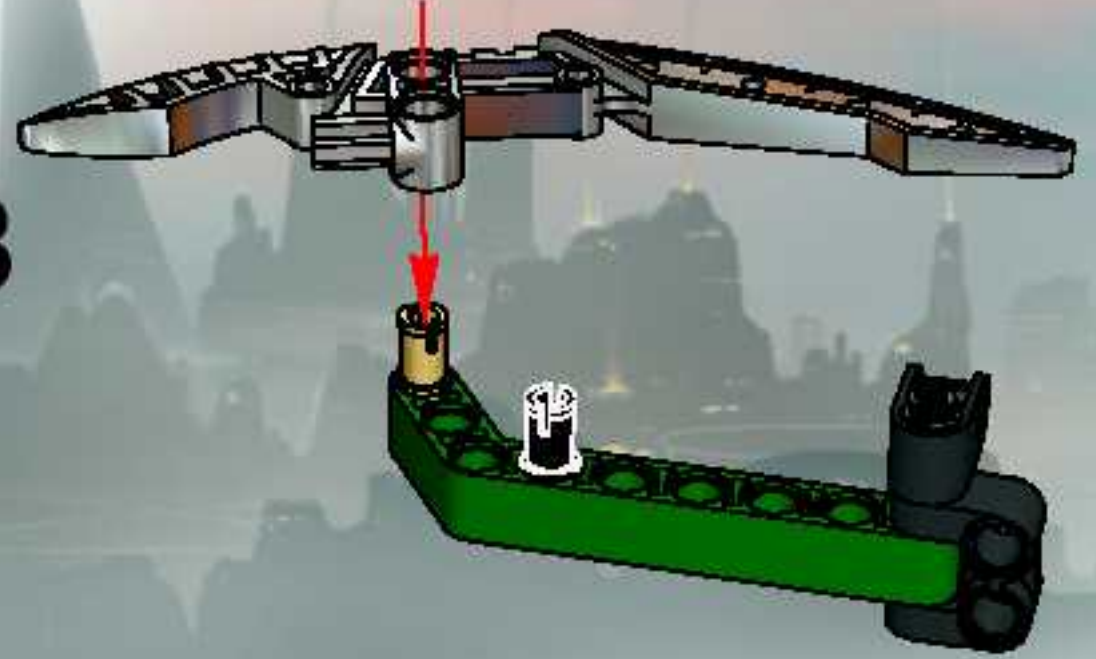

1



2



4

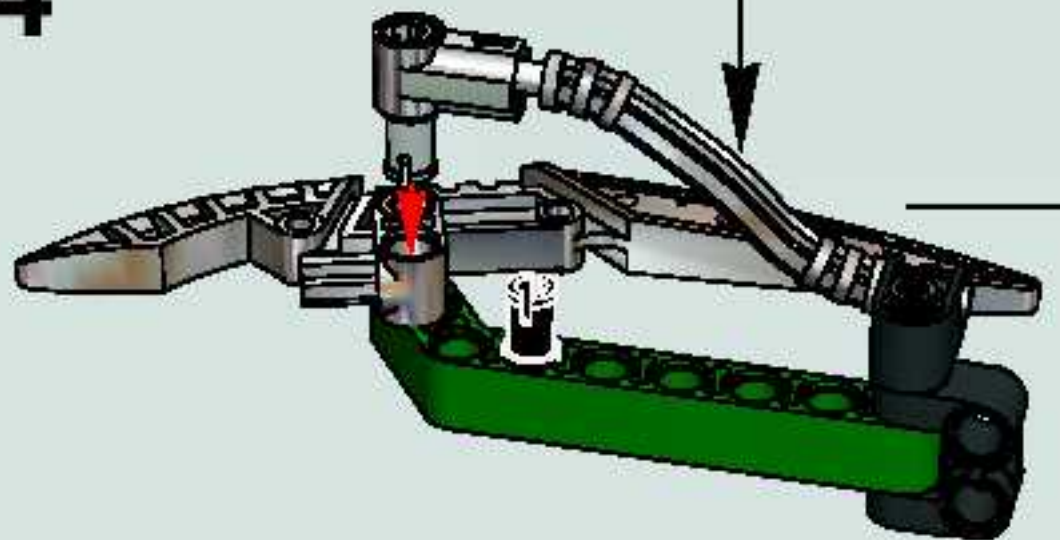

2x

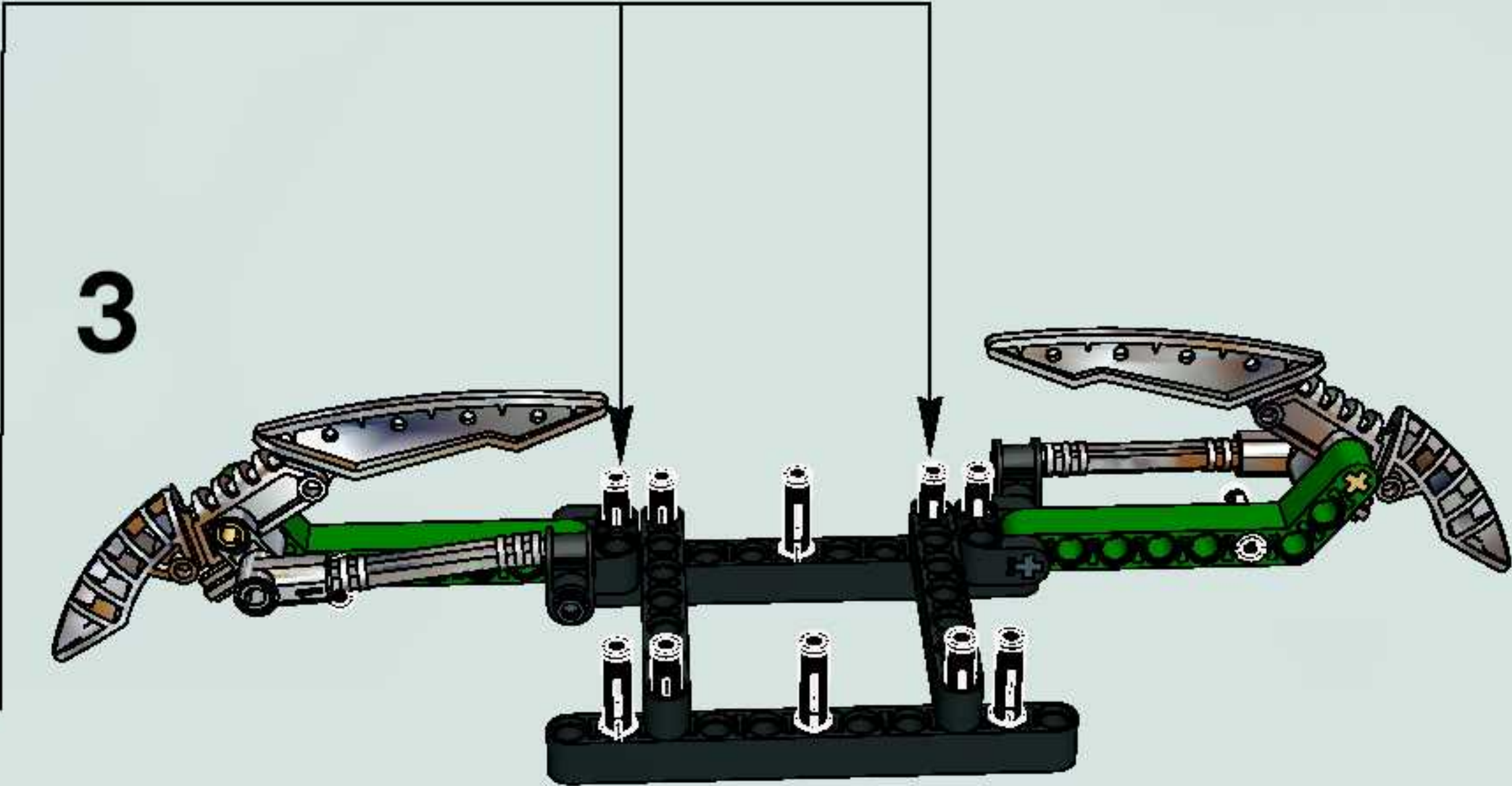



4

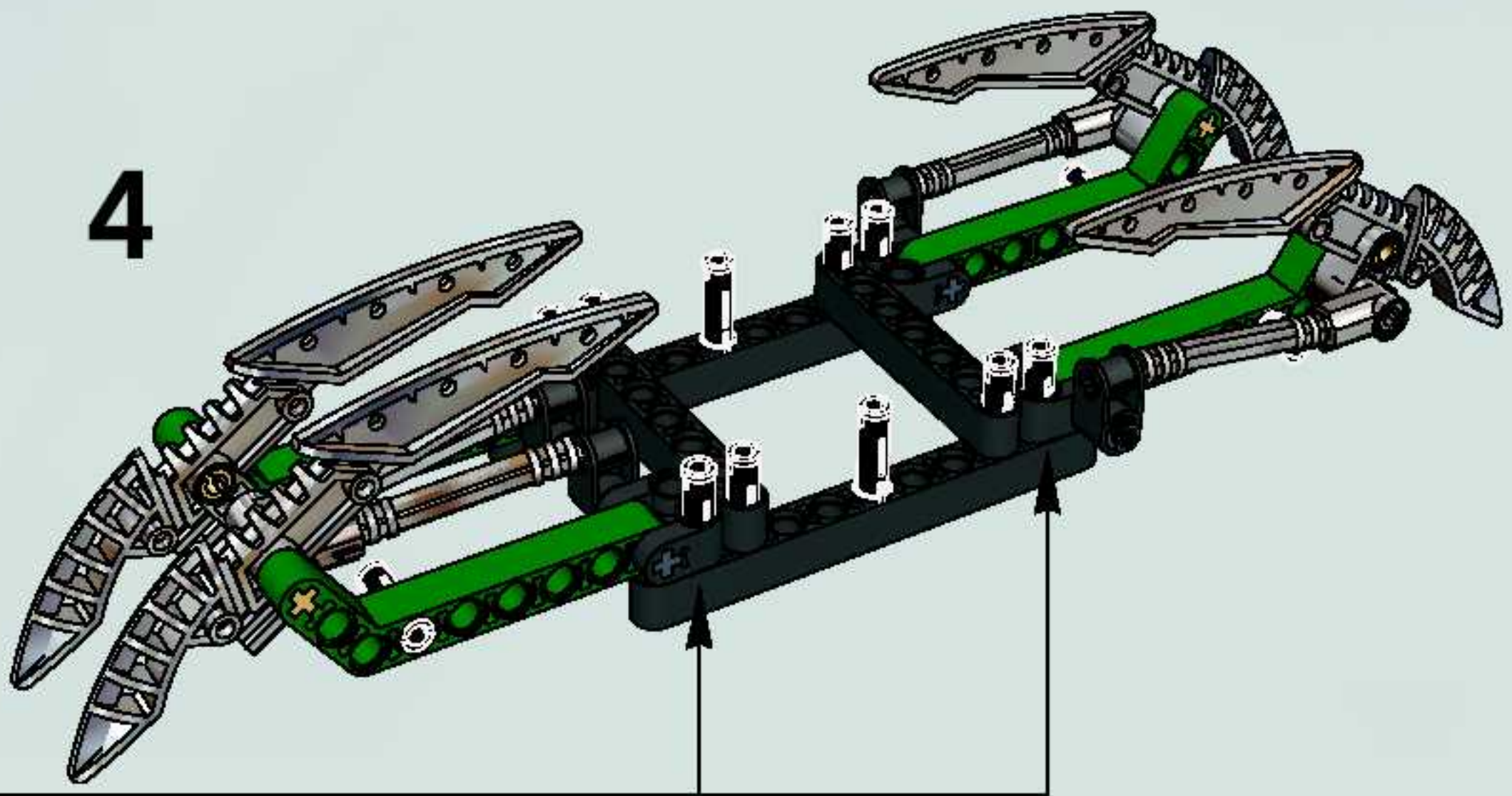

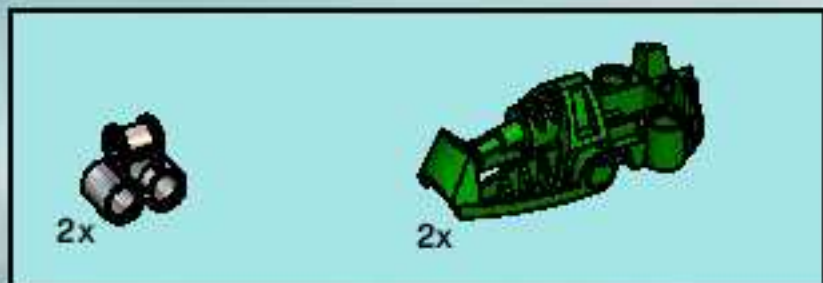

5

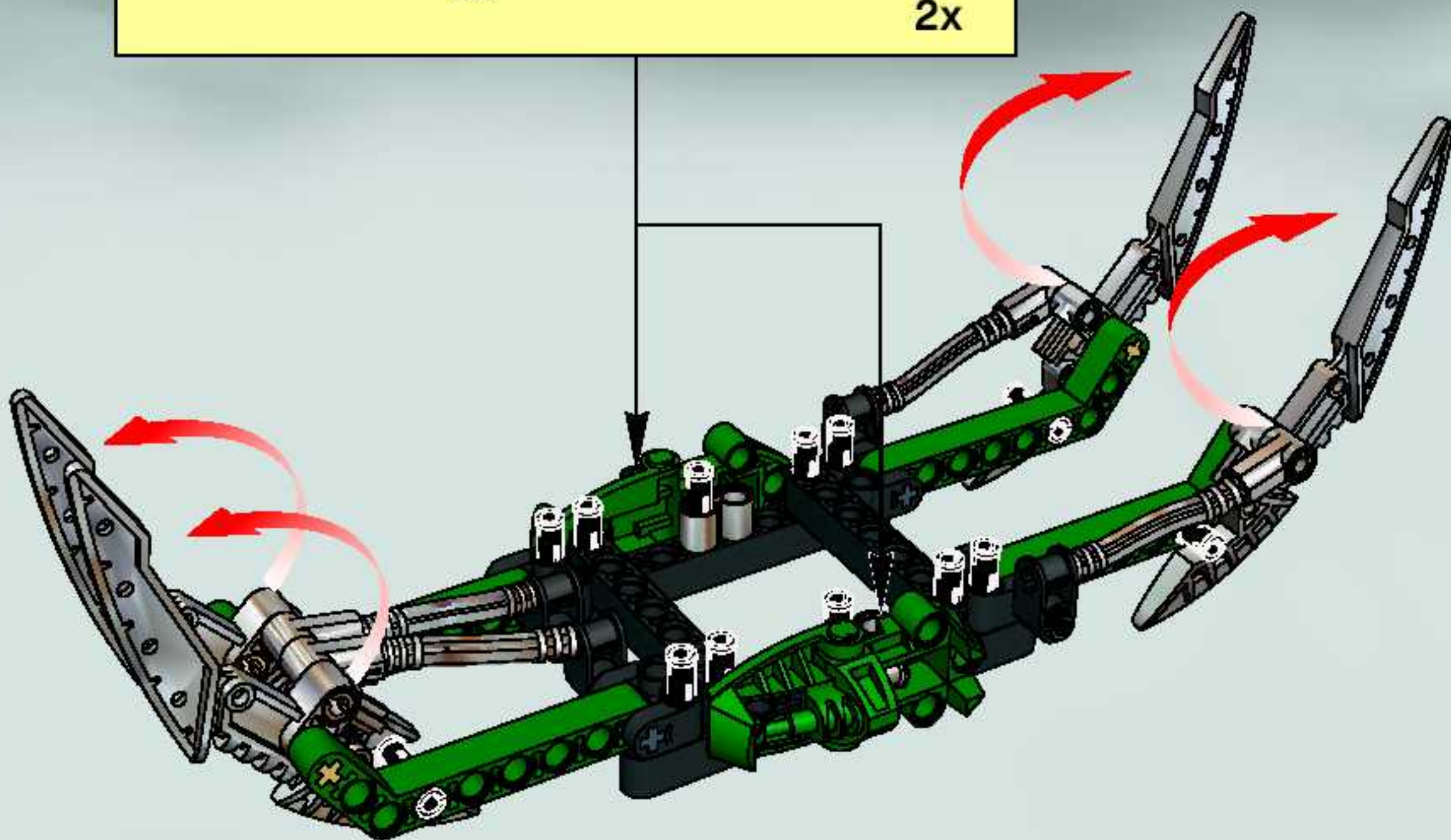
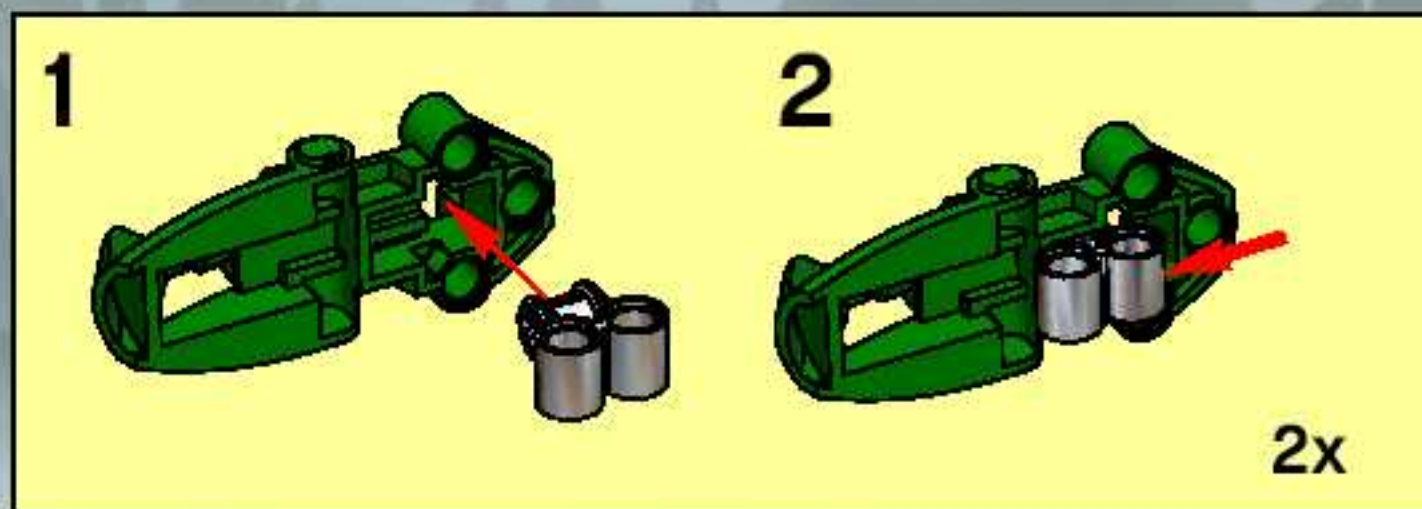

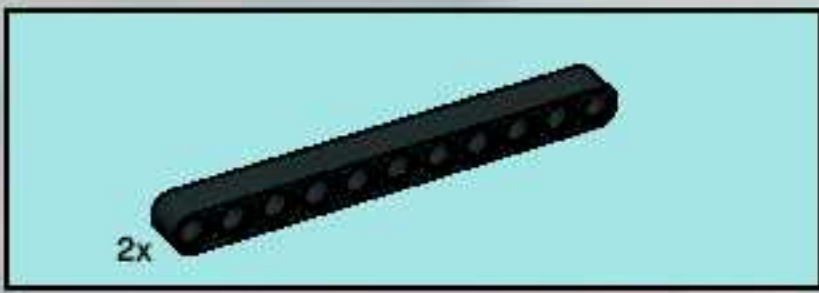

6

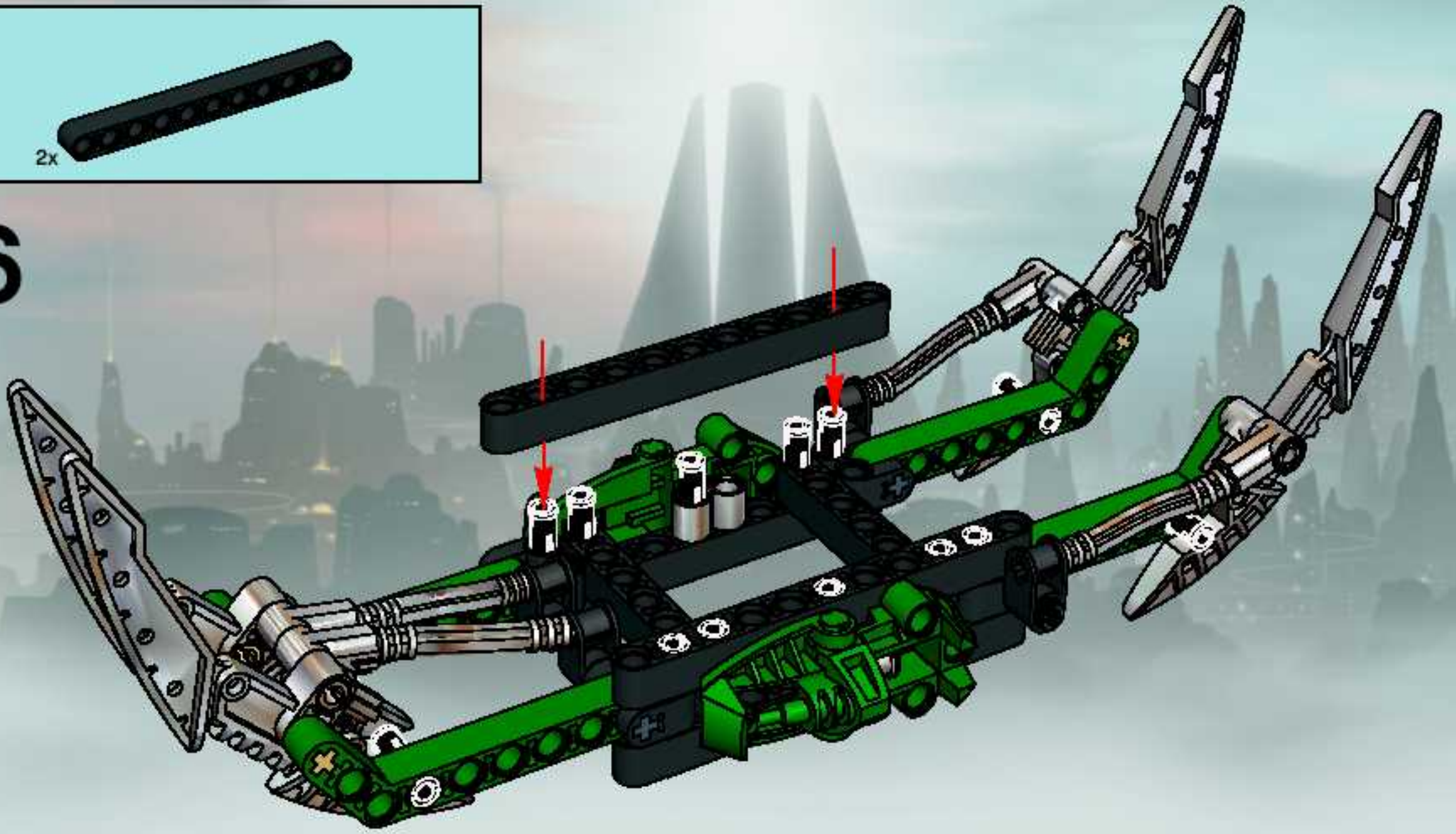

7

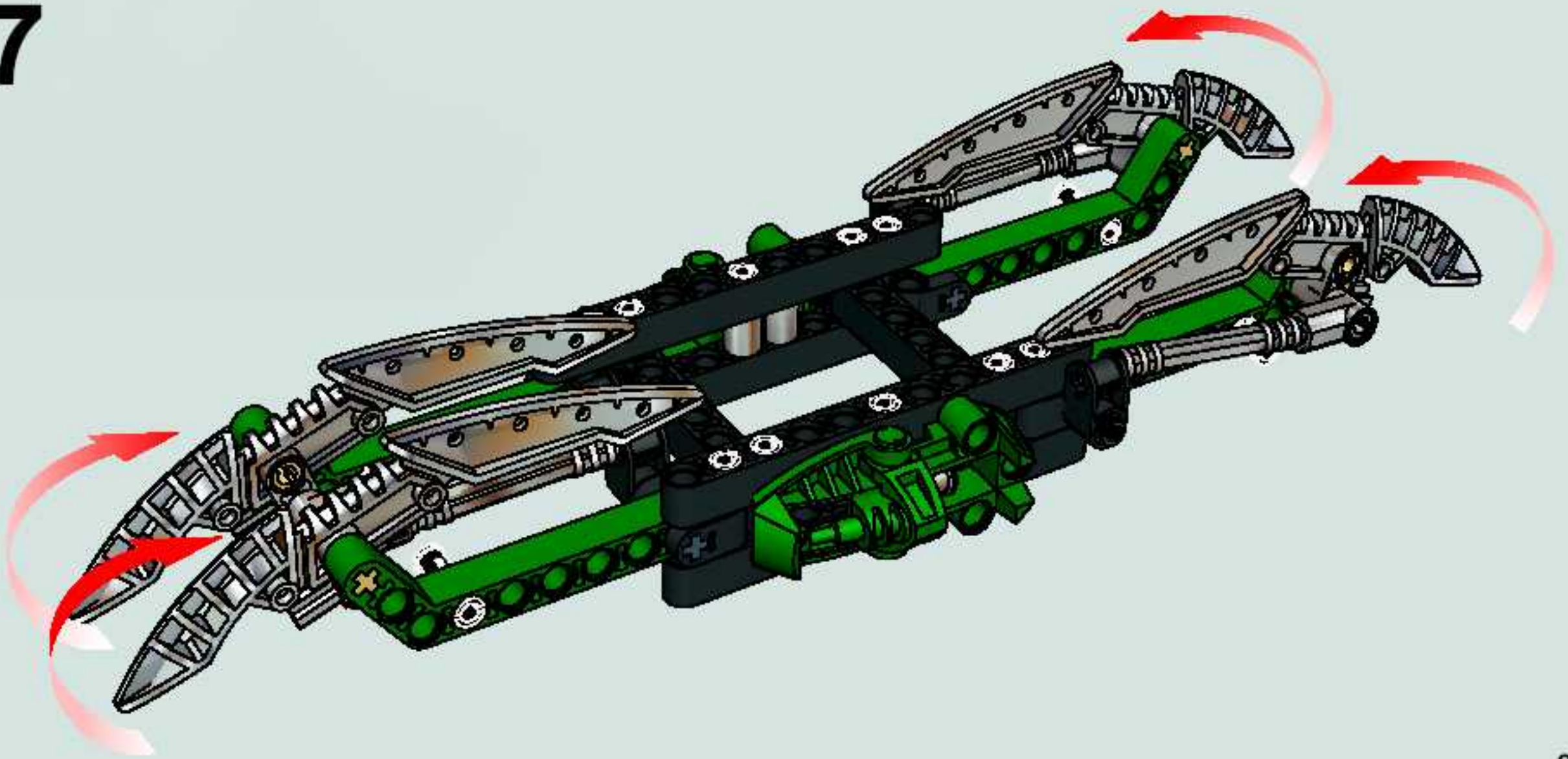



8

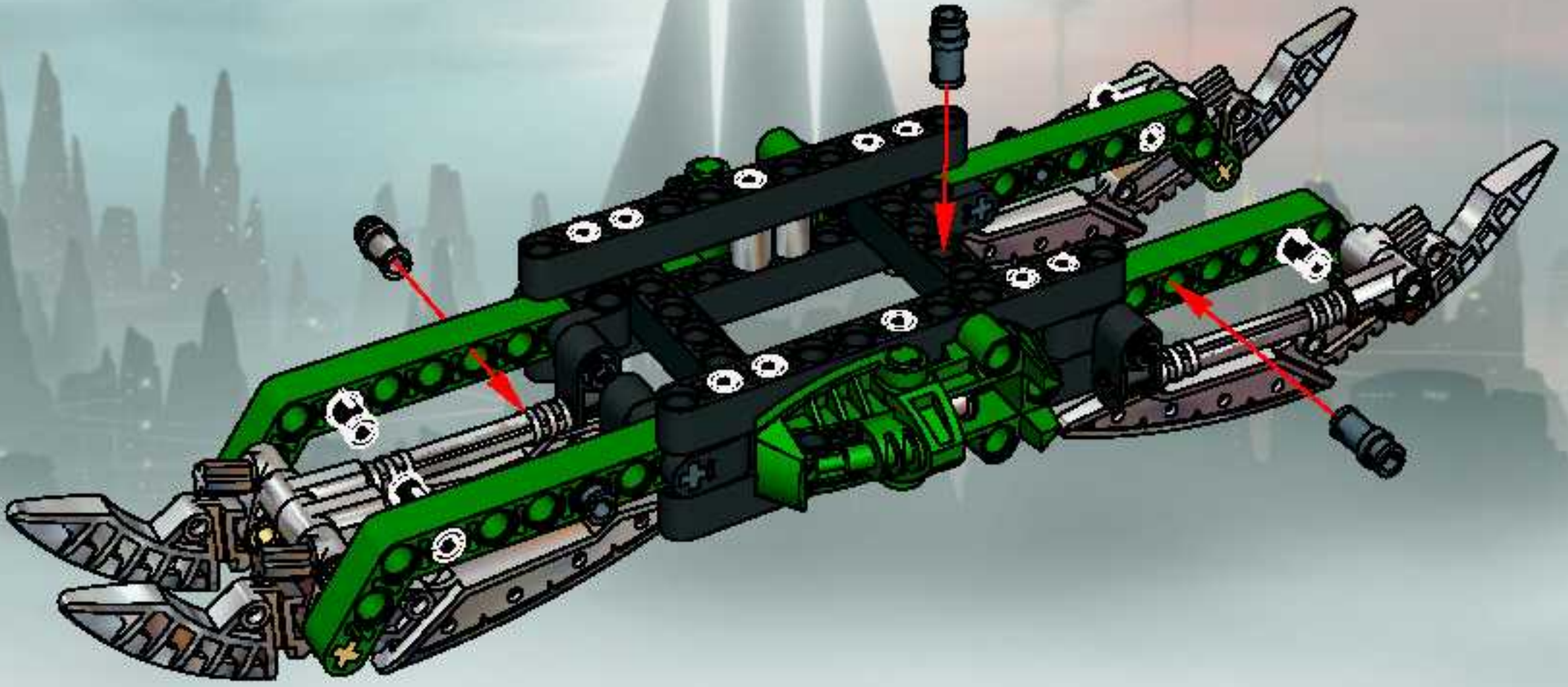

9

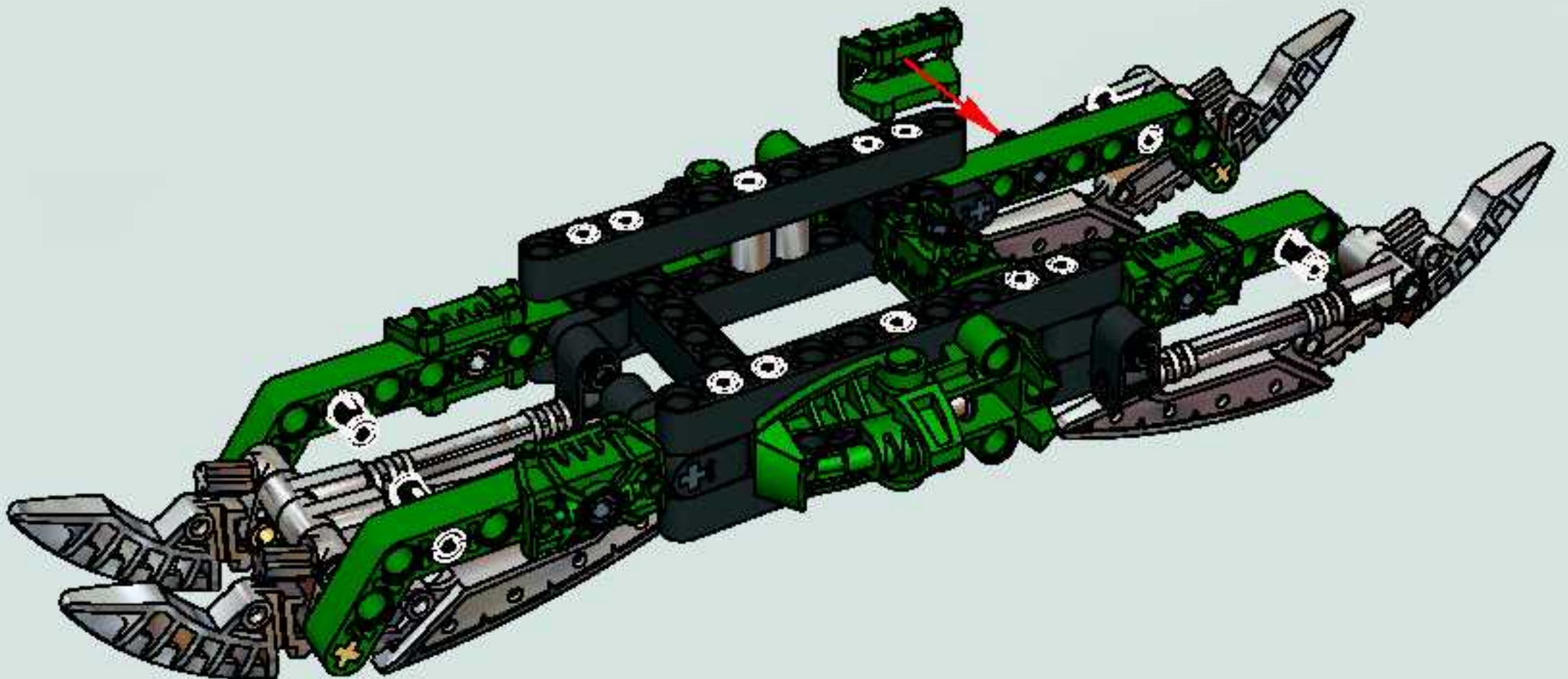

BIONICLE

2



8622

ПЧН44

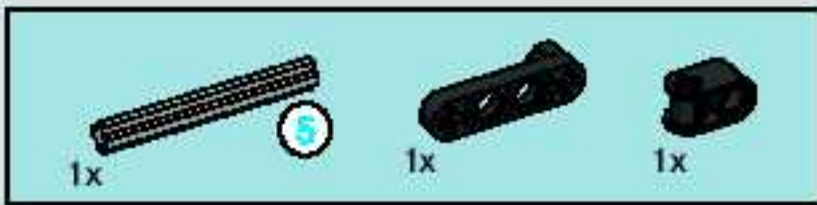
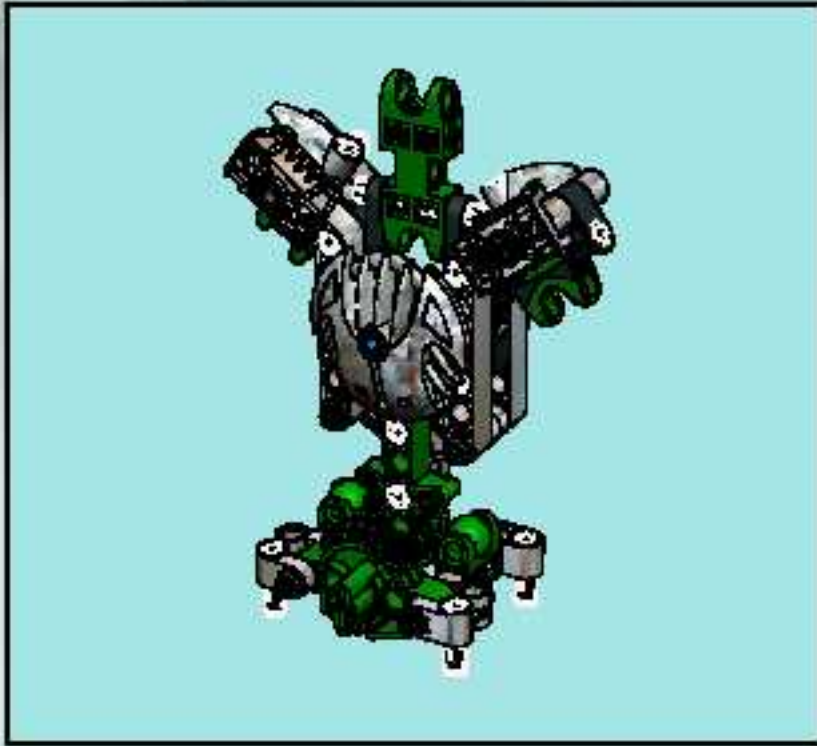

1

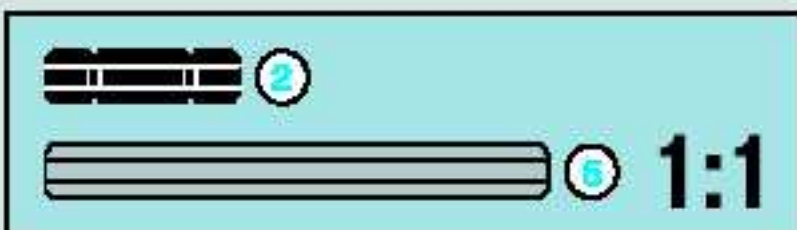
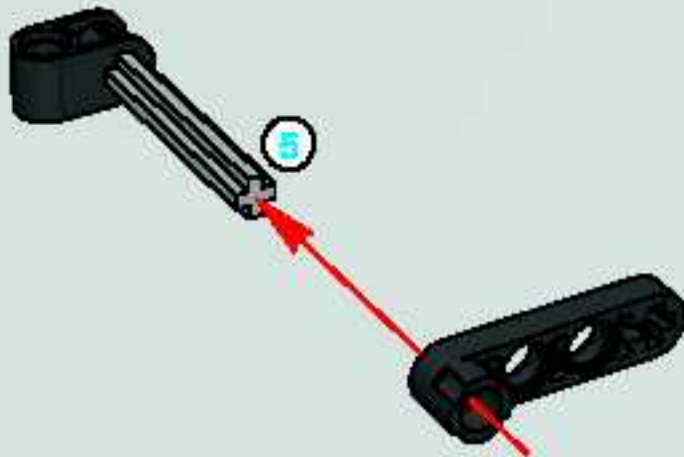

2

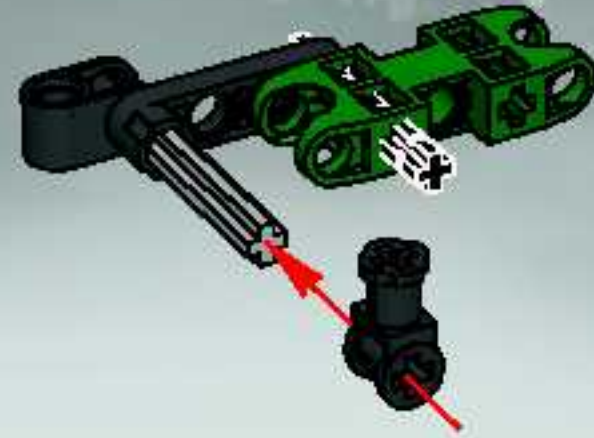
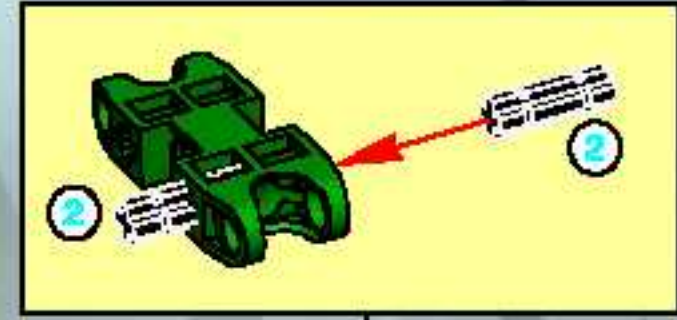

3

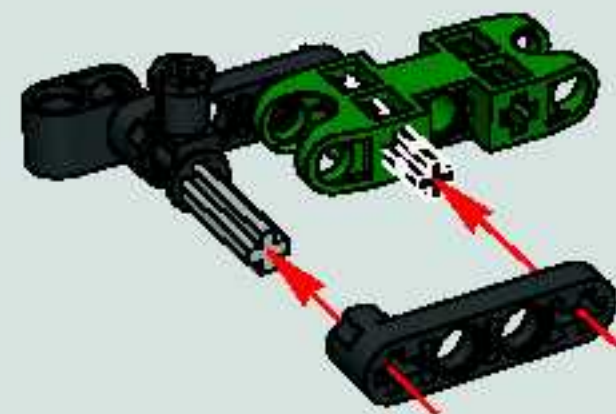



4



5

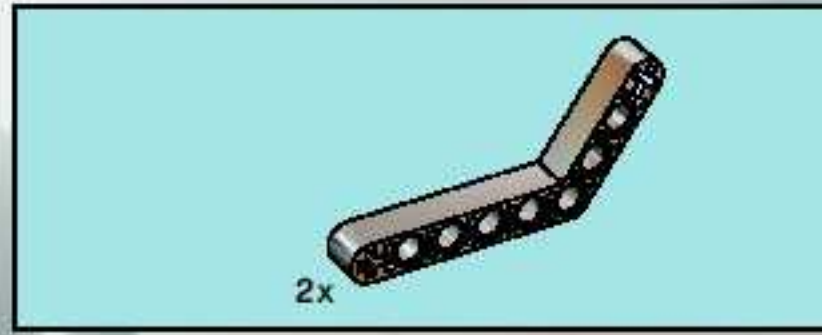
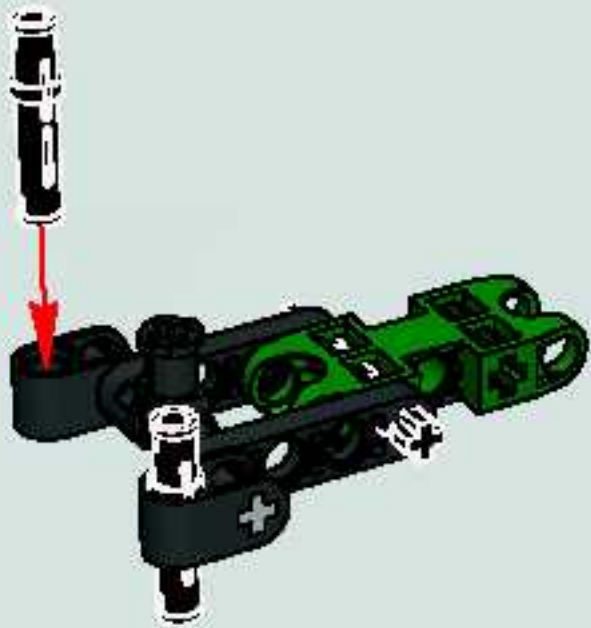

6

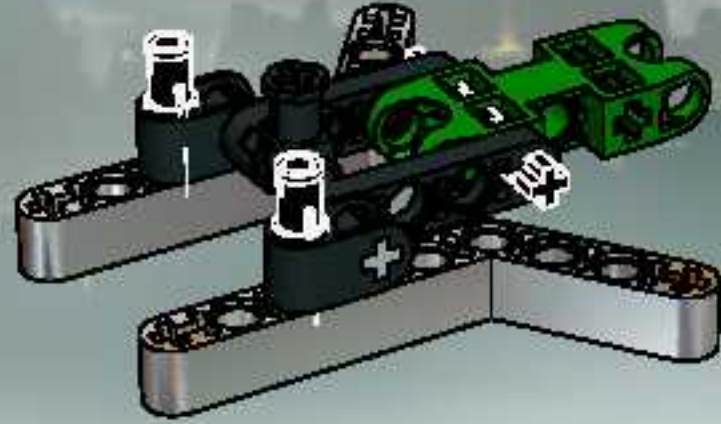

7

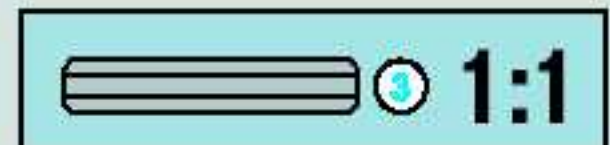
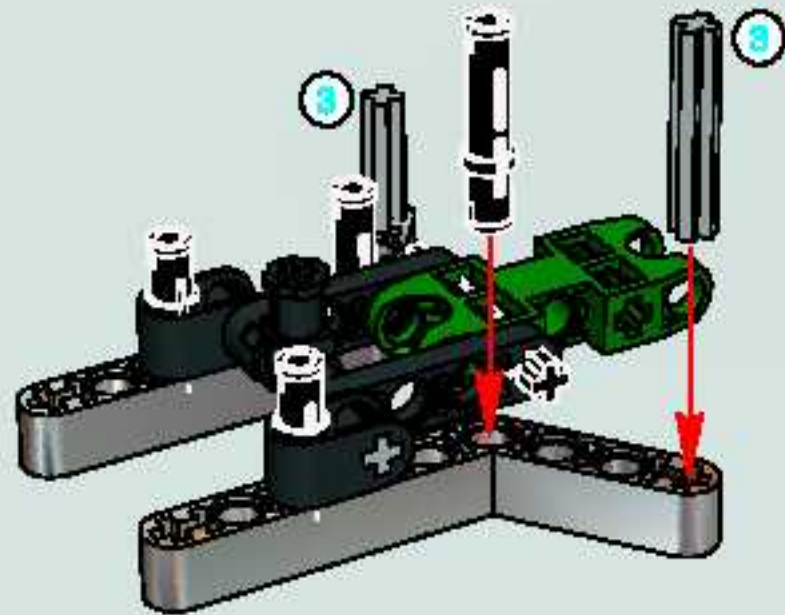



8

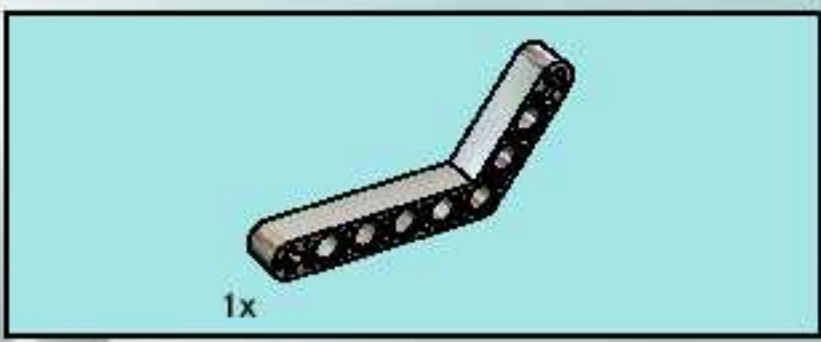
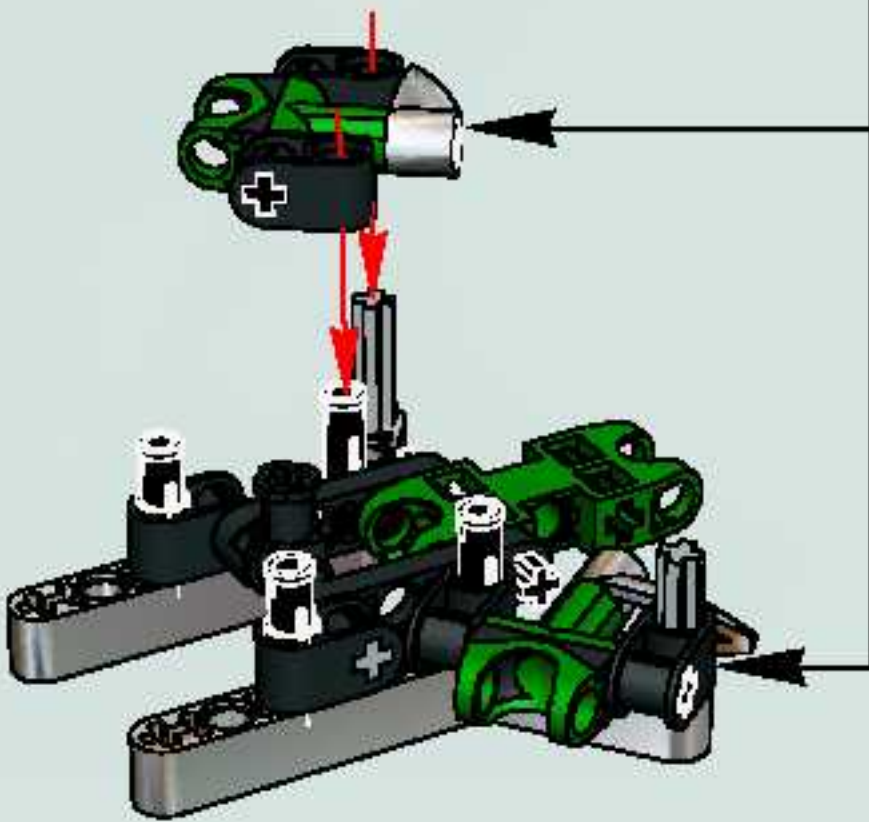
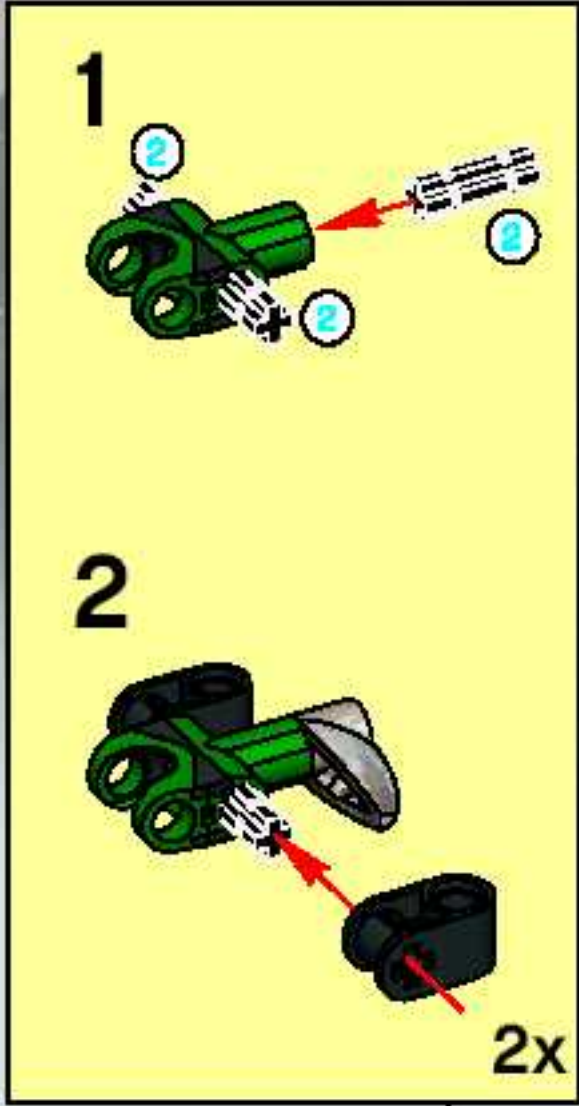

9

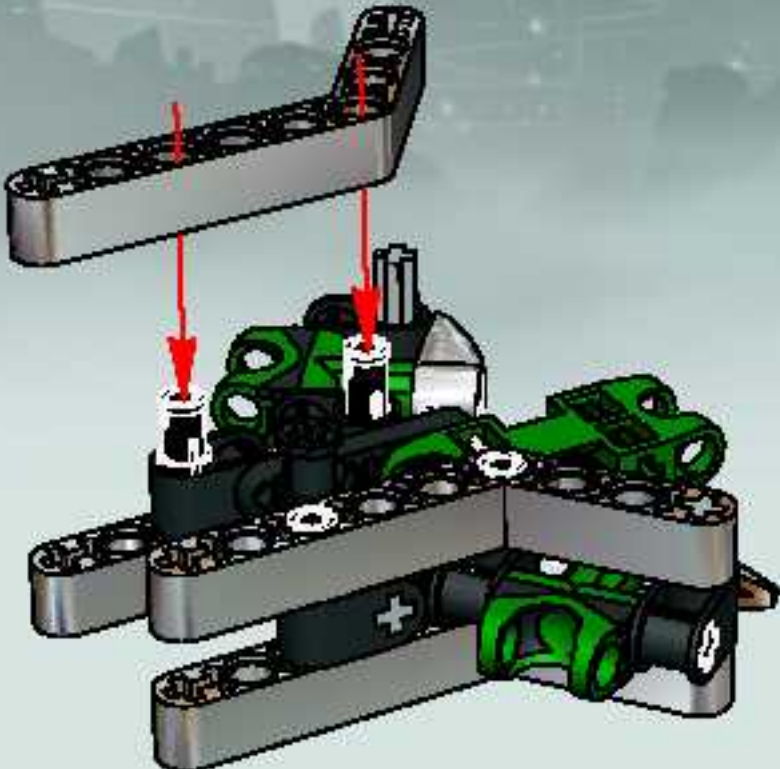

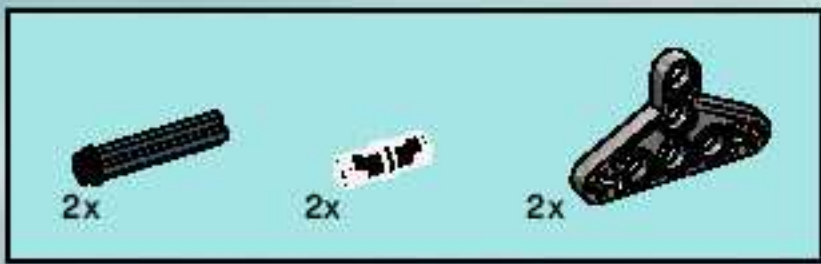

10

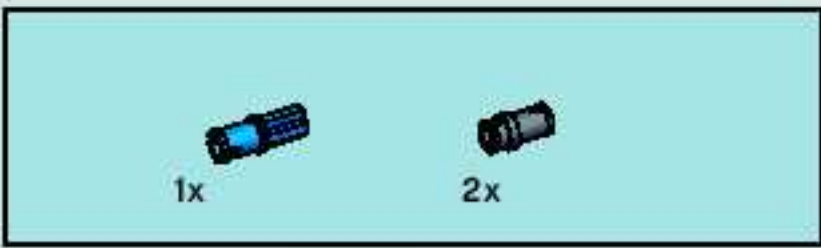
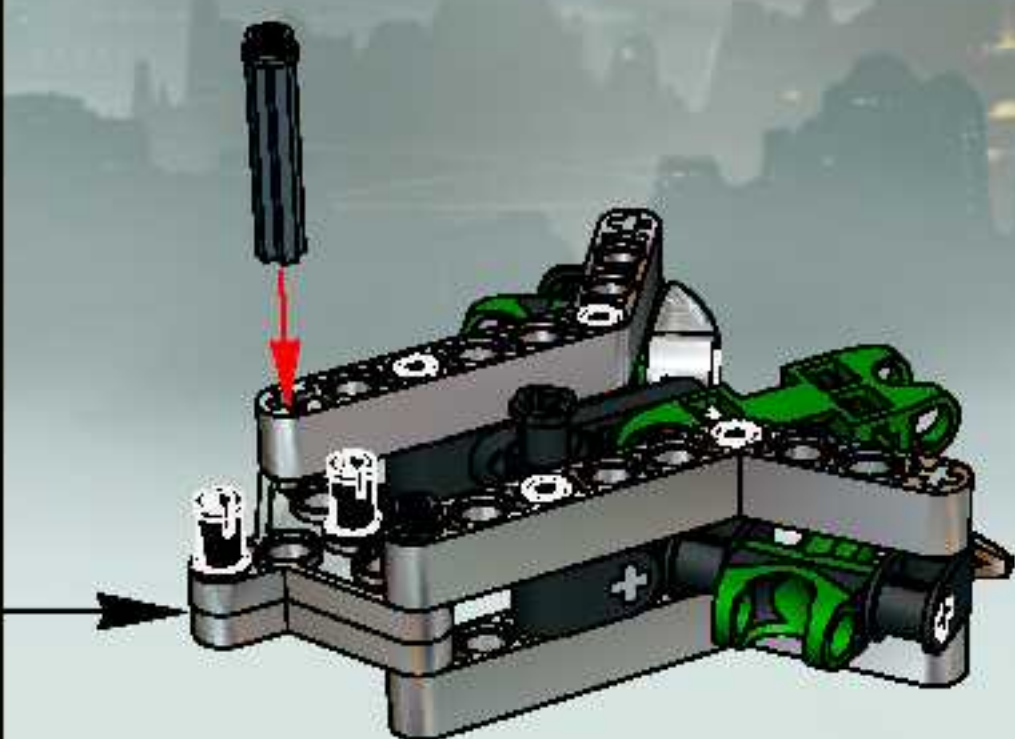
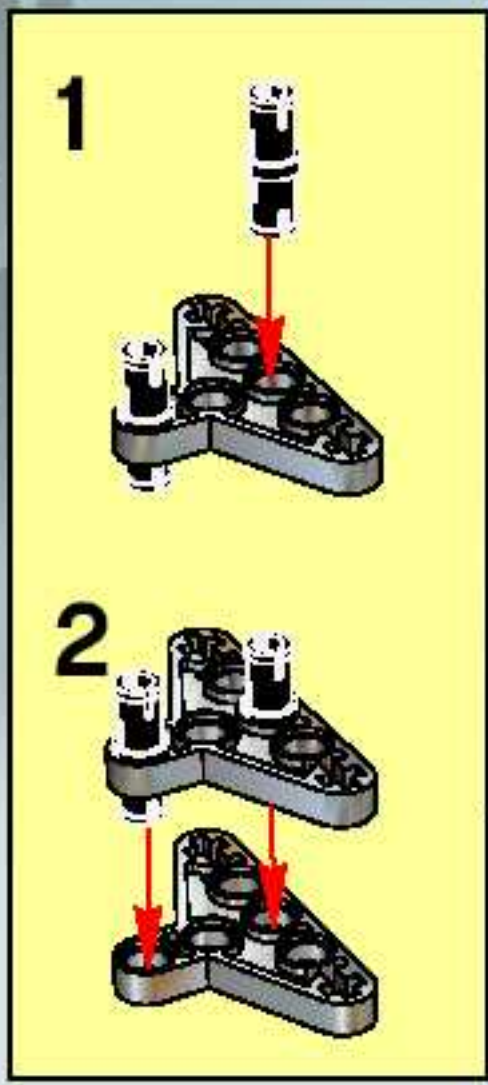

11

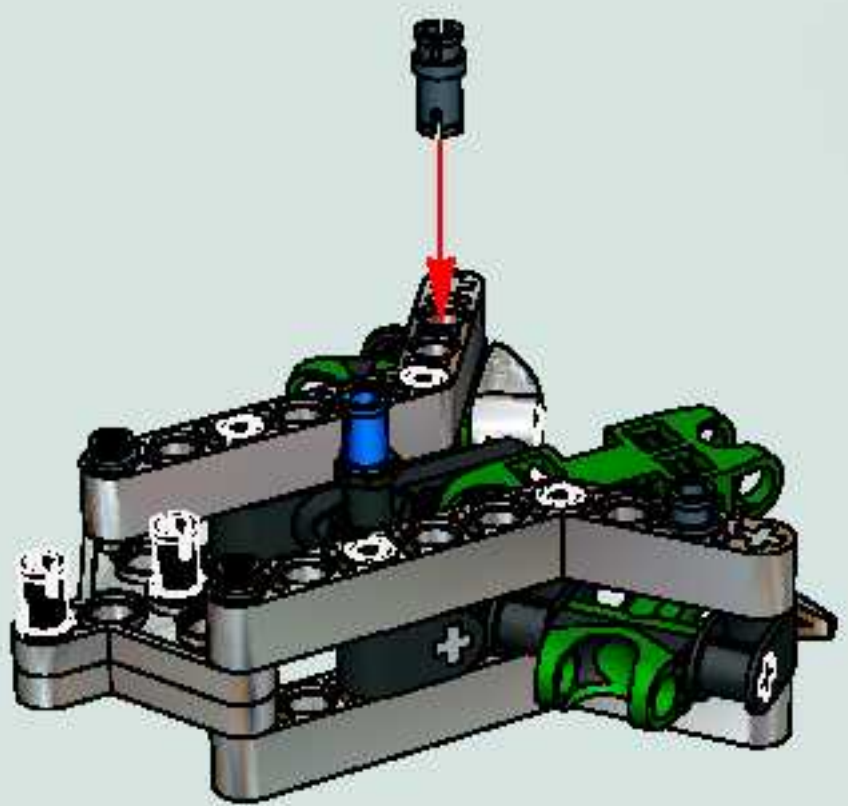

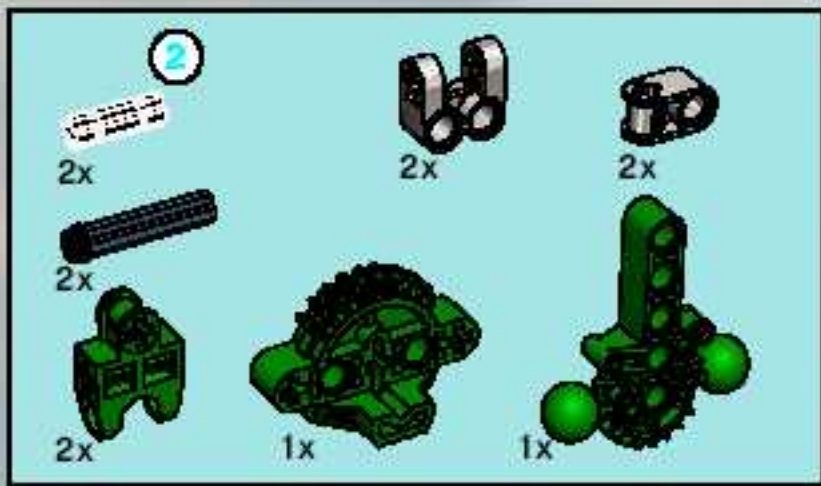

12

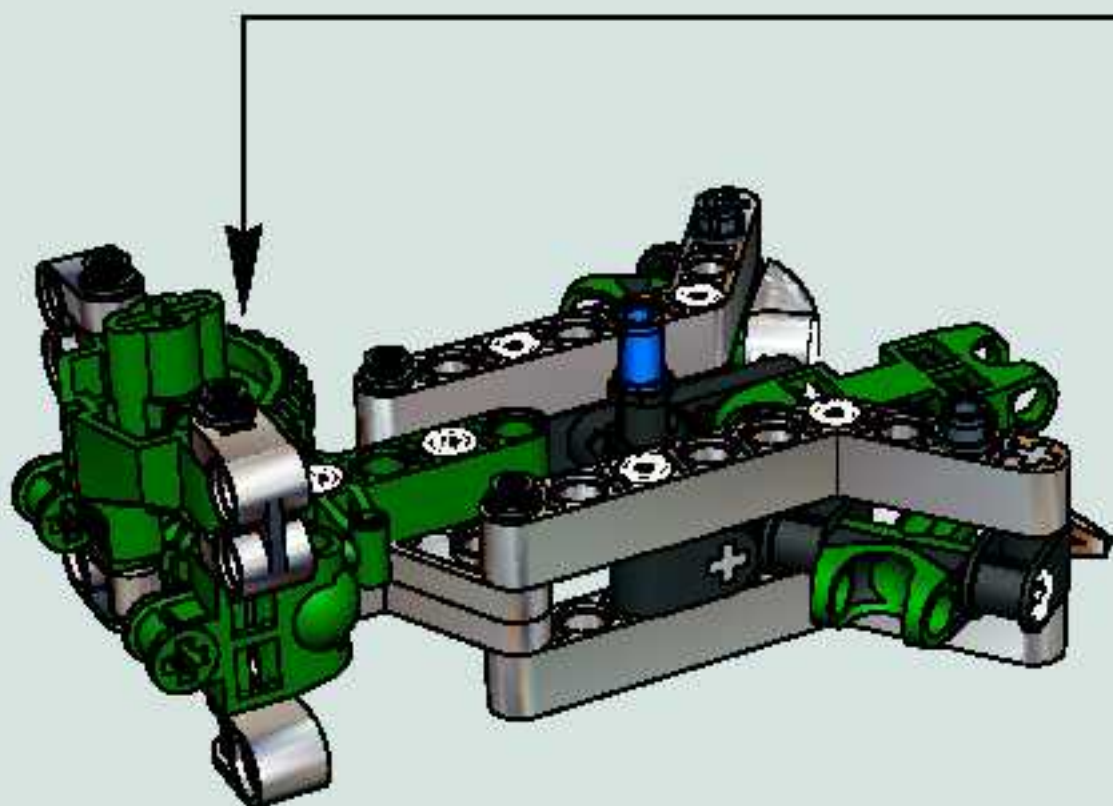
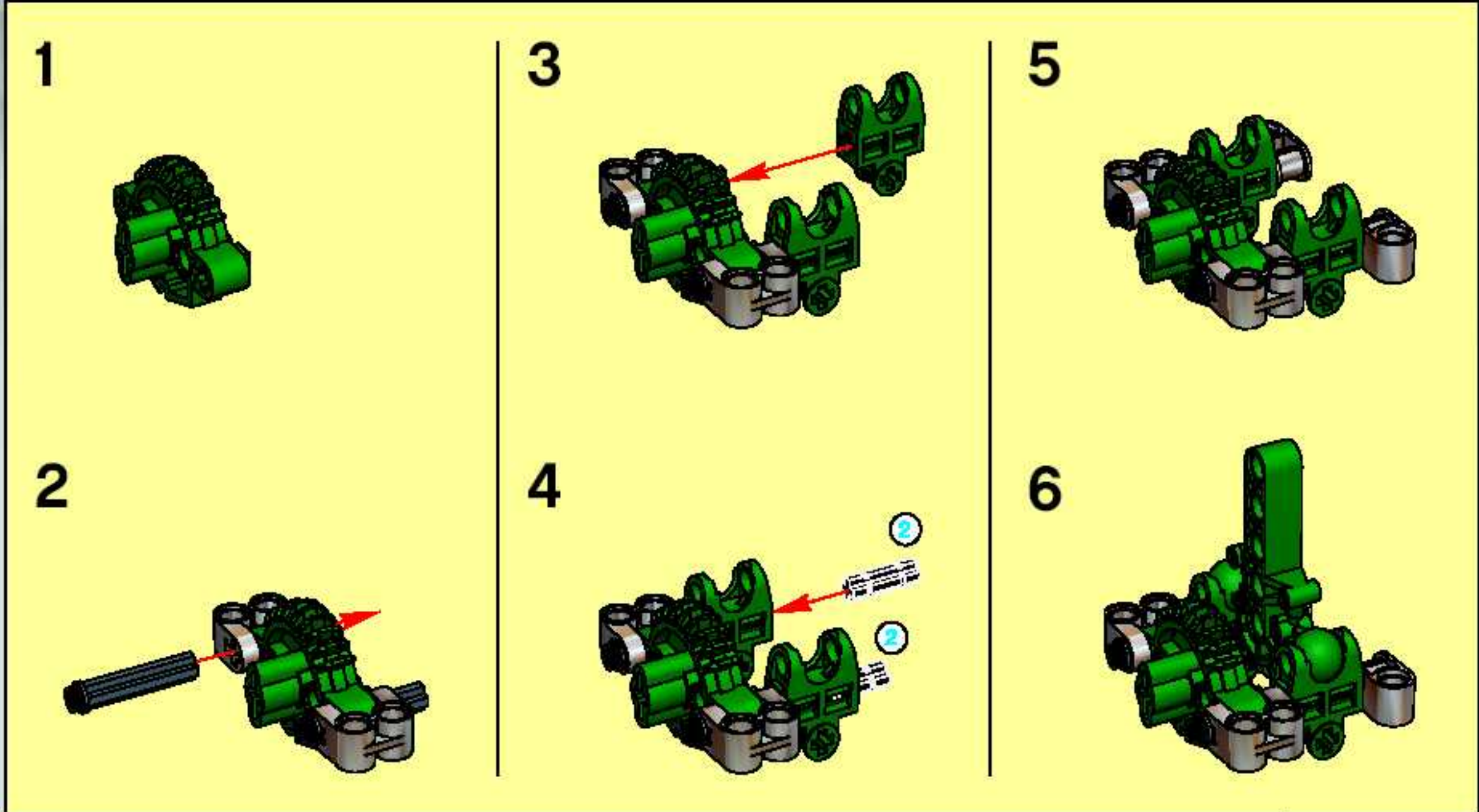



13

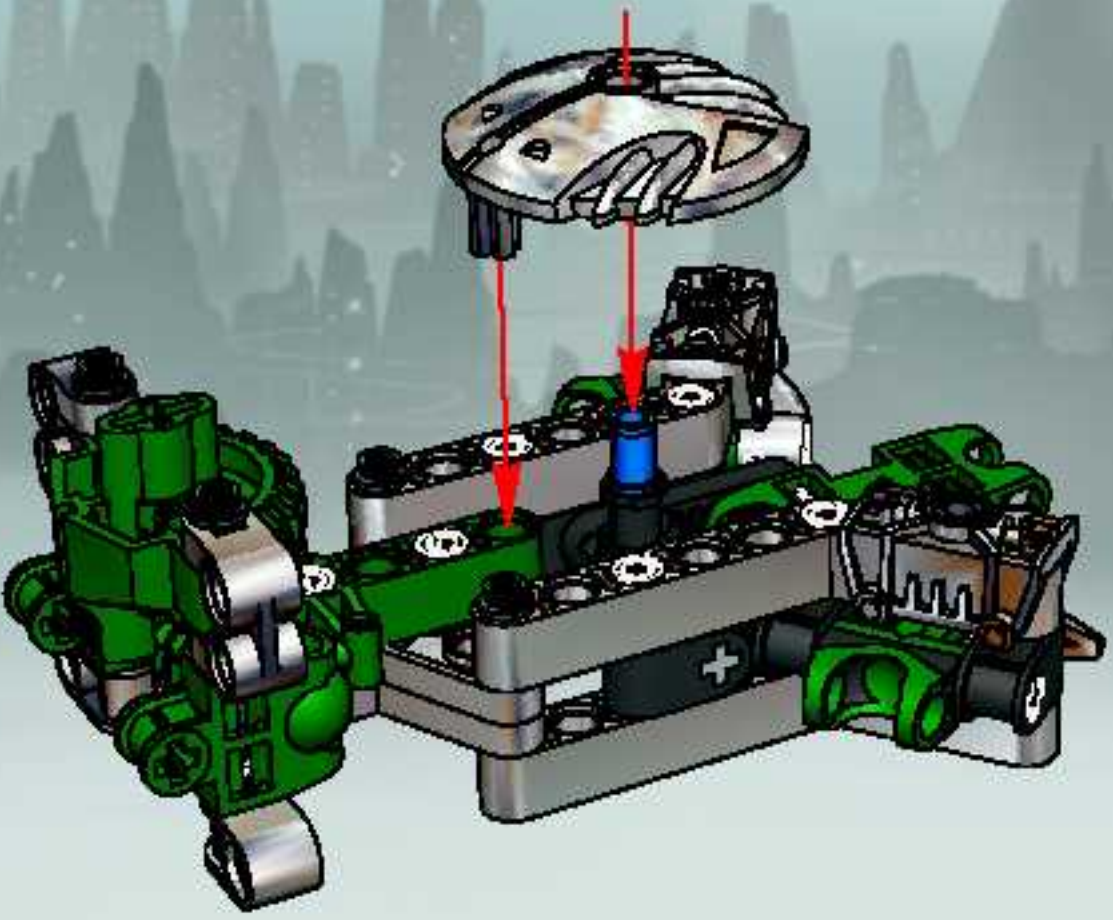

14

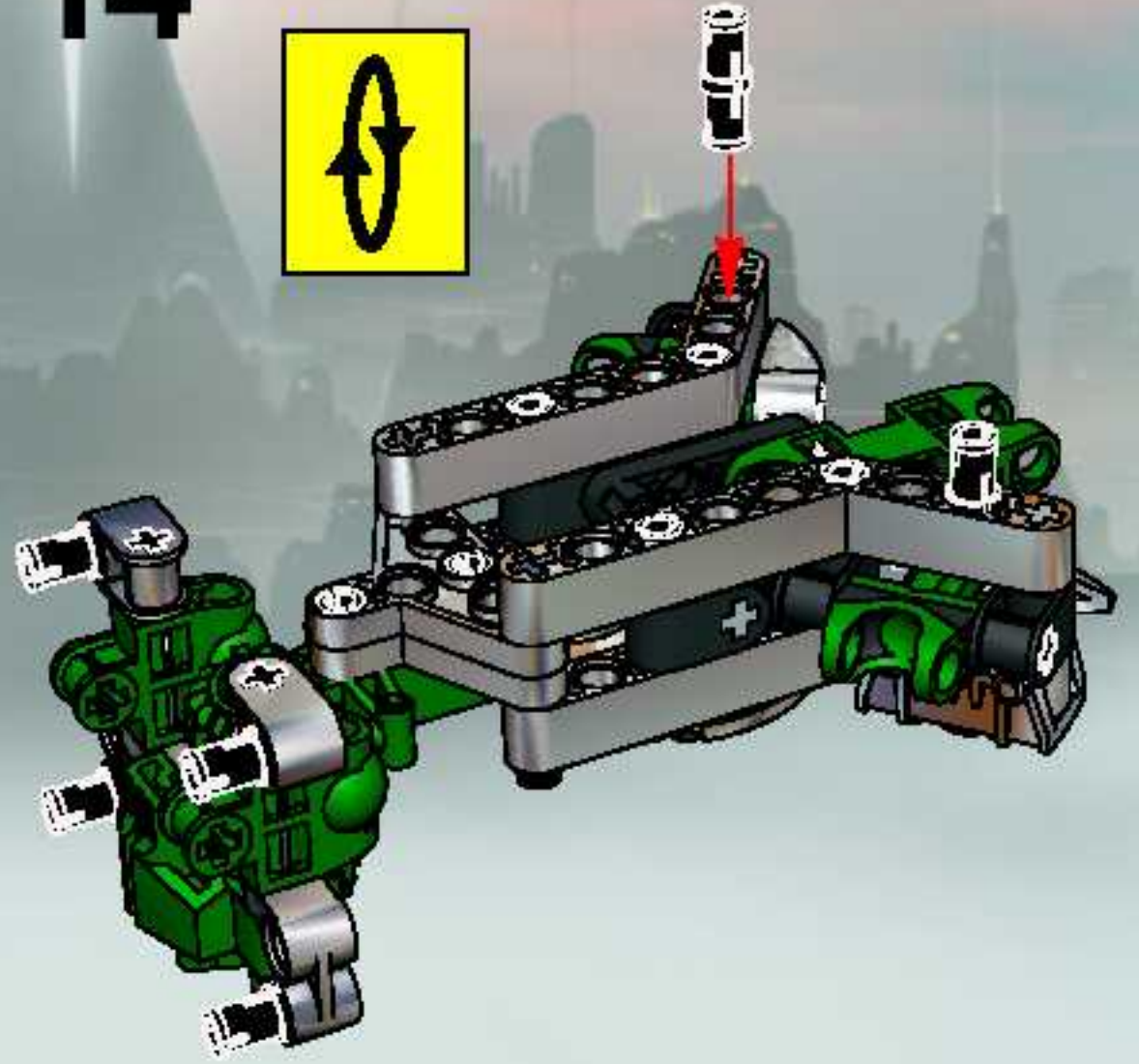

15

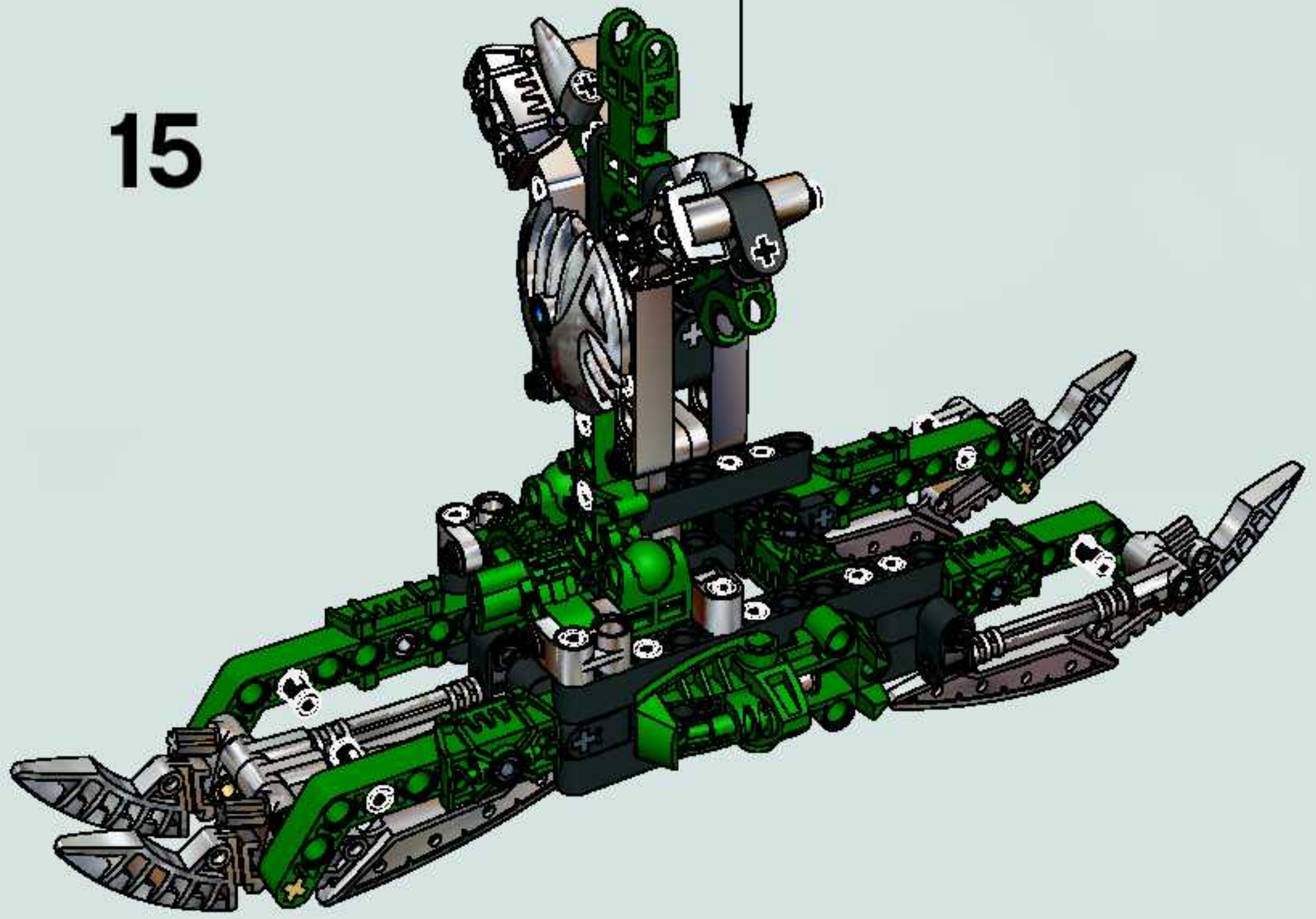

BIONICLE

3

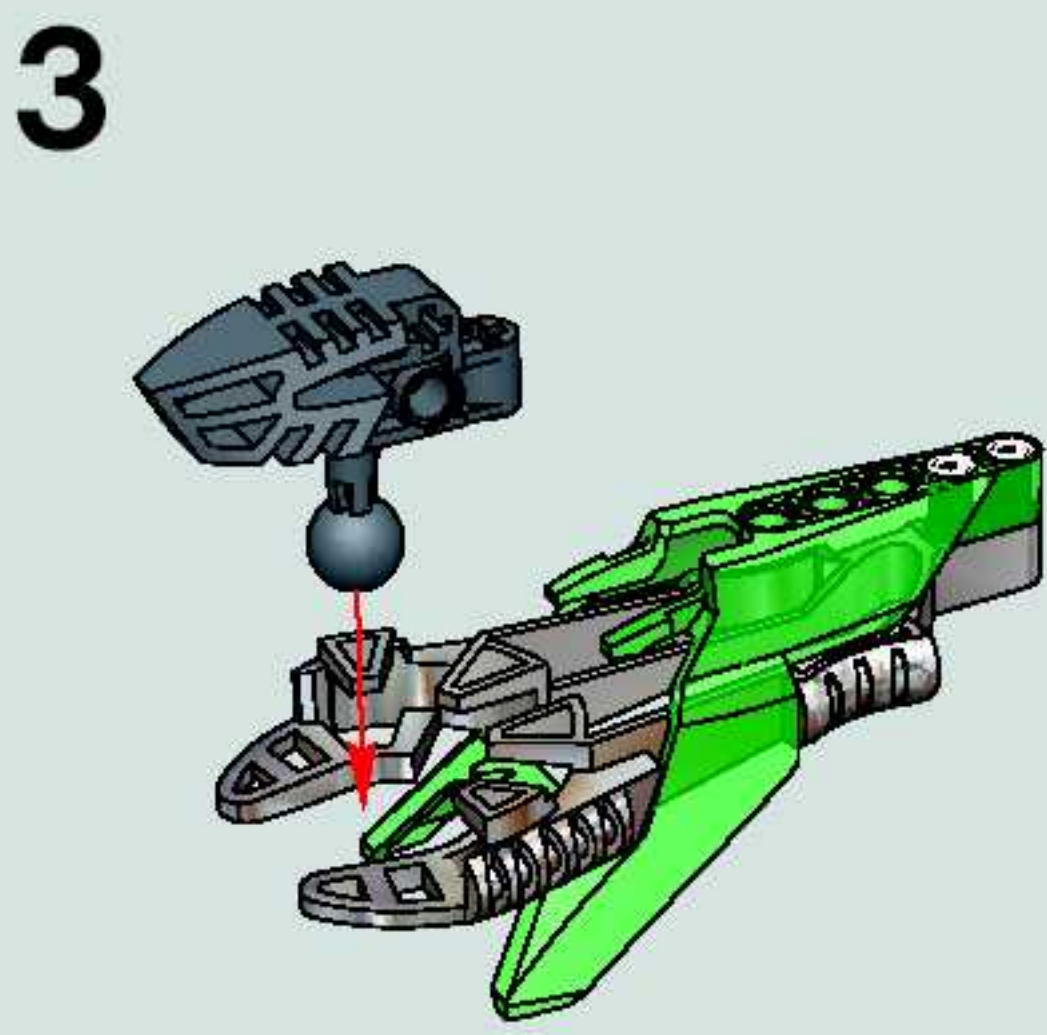
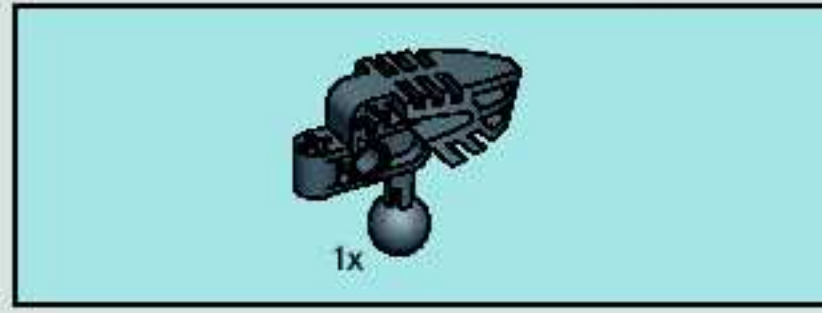
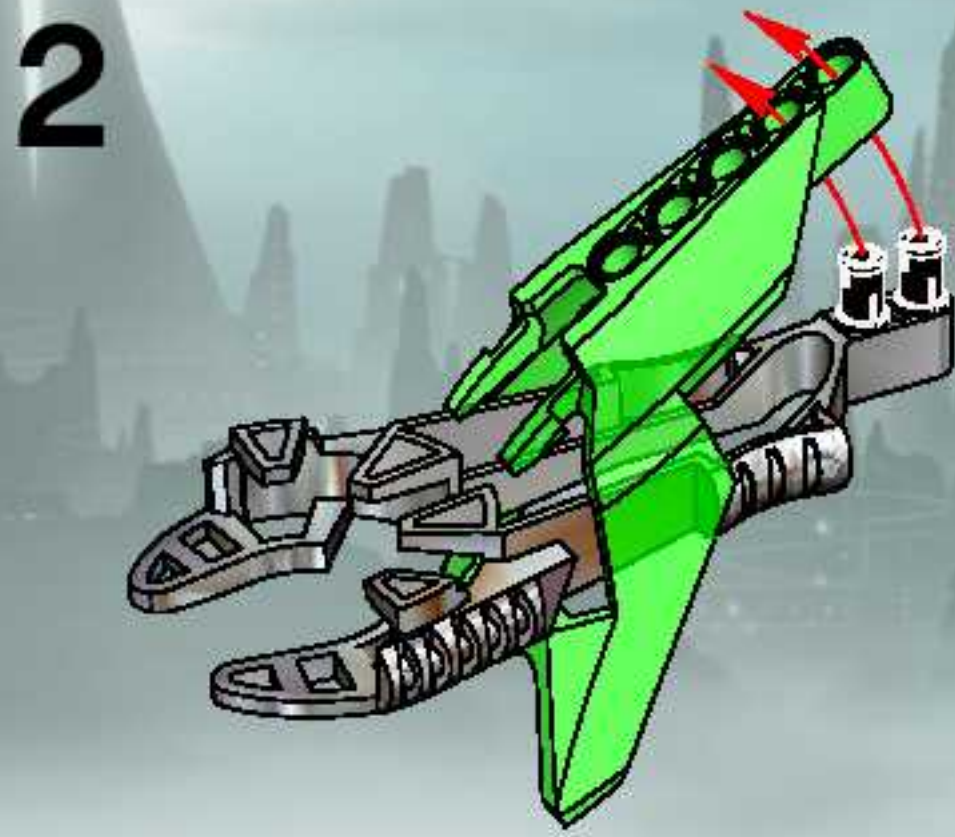
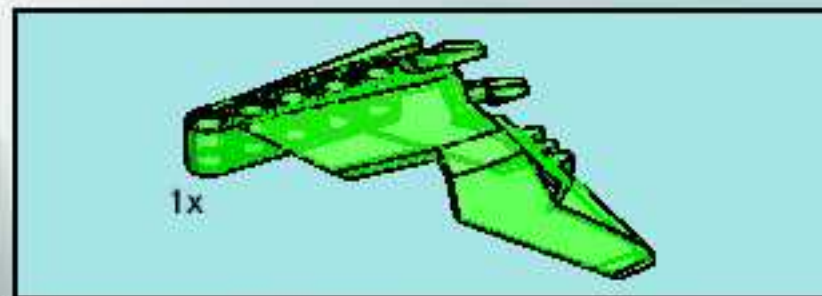
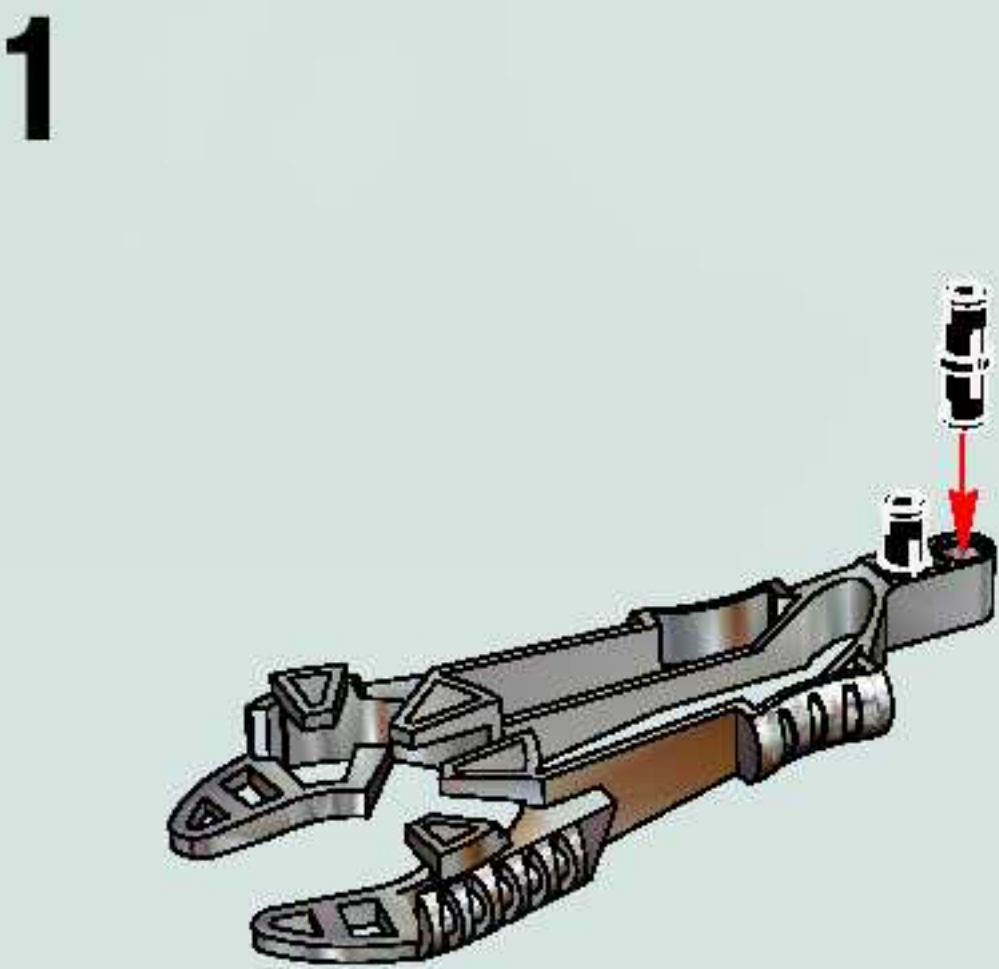
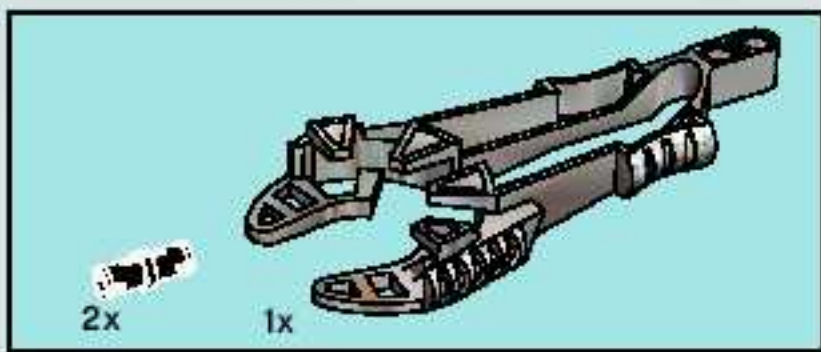
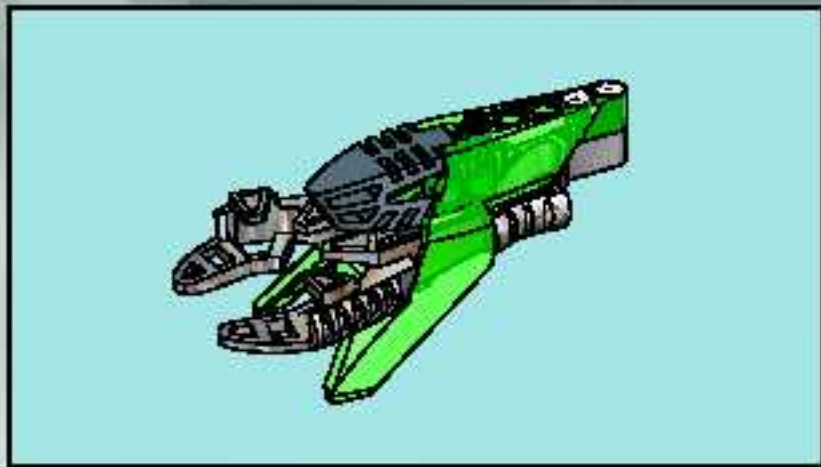

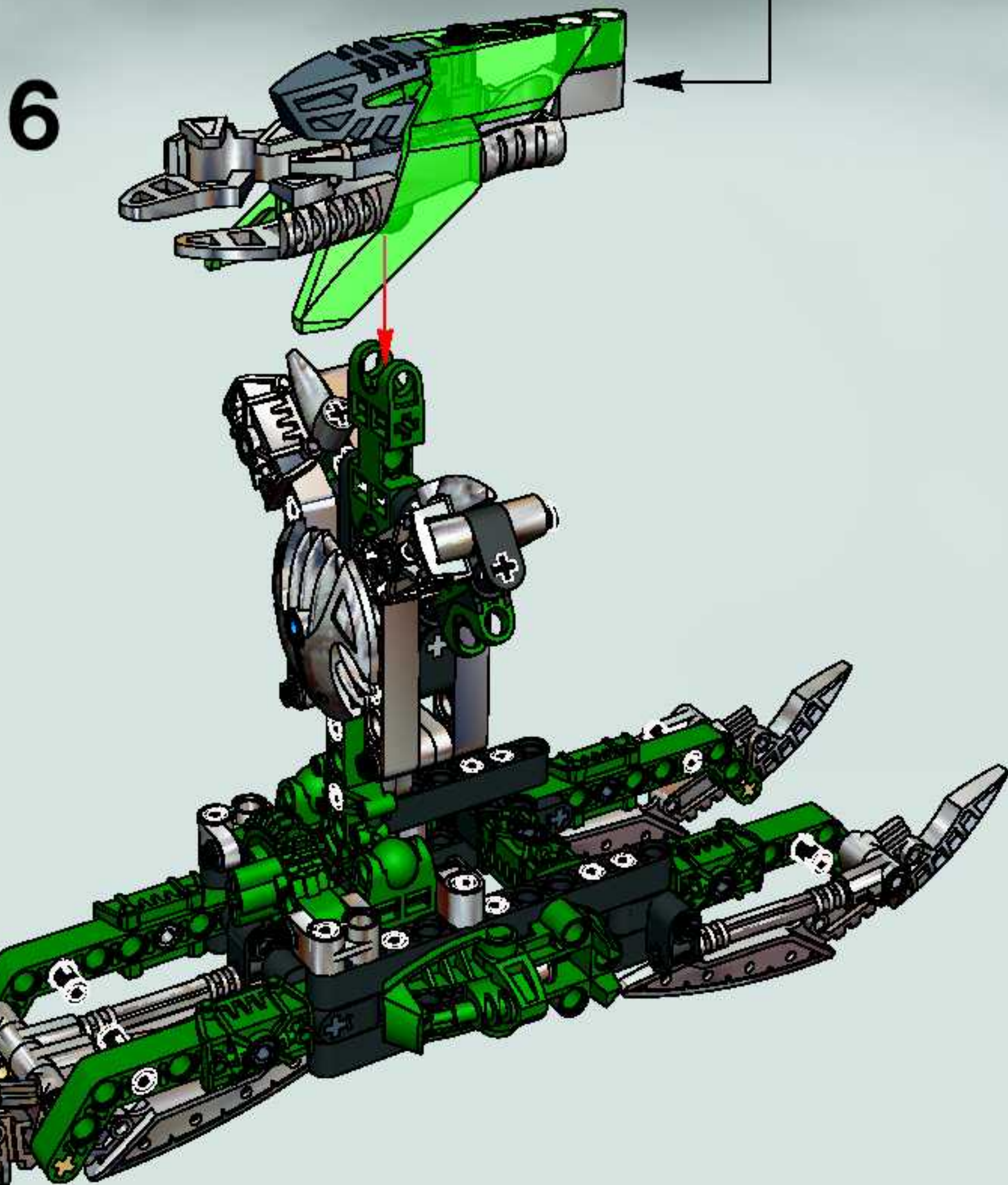
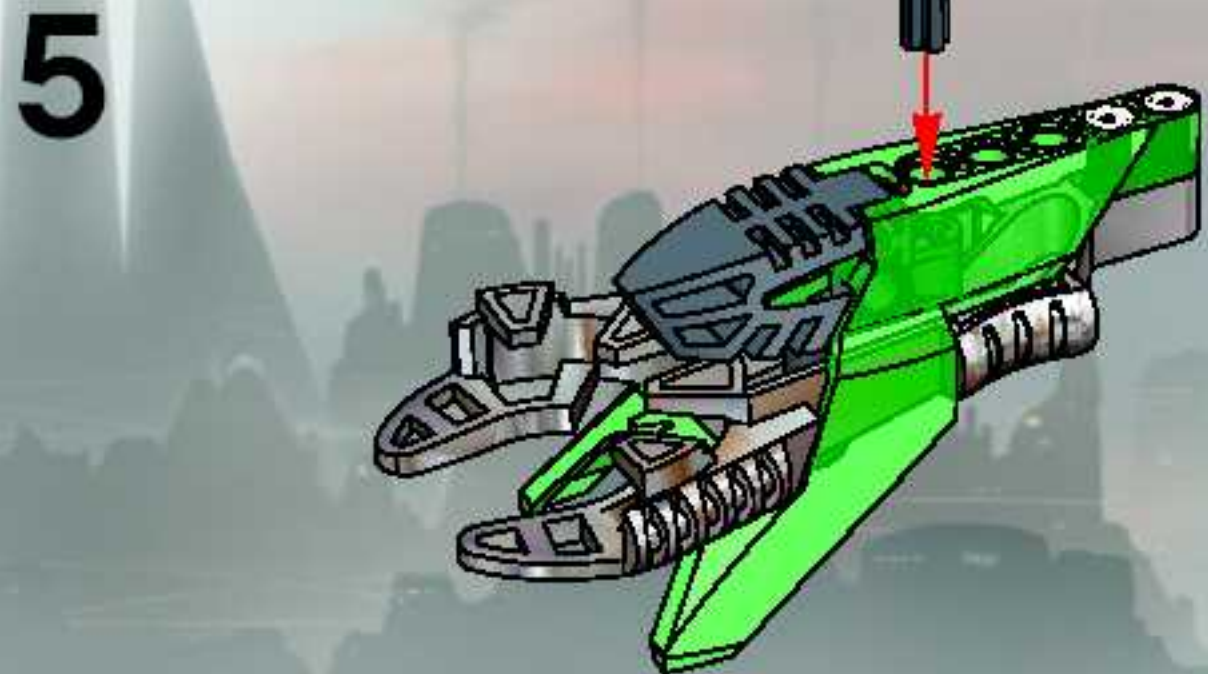
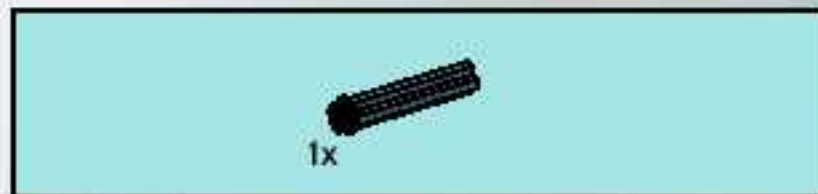
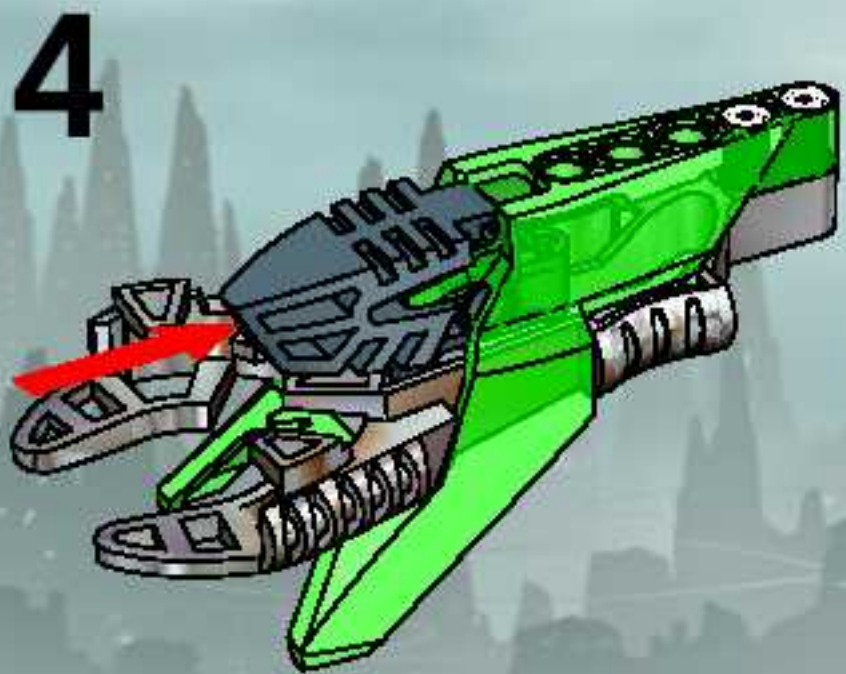

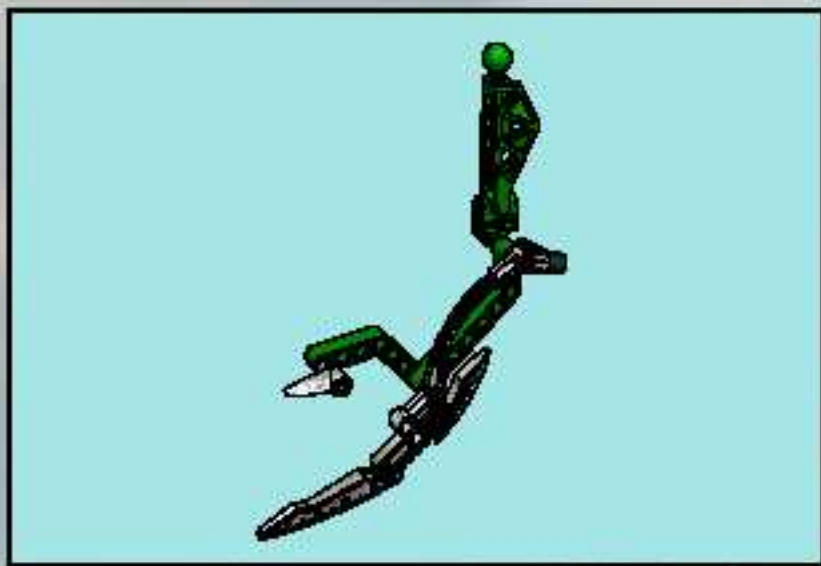

1

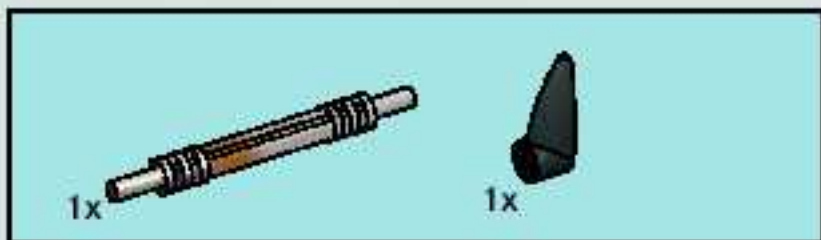
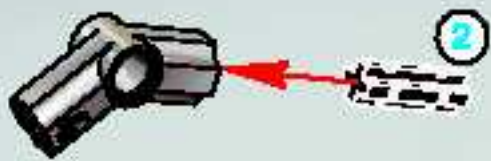

2

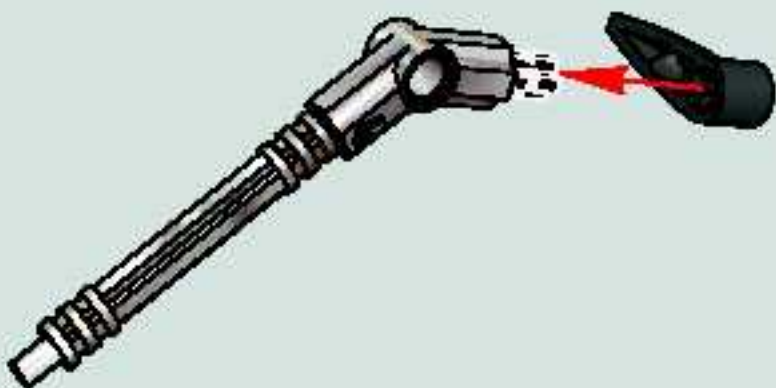

3

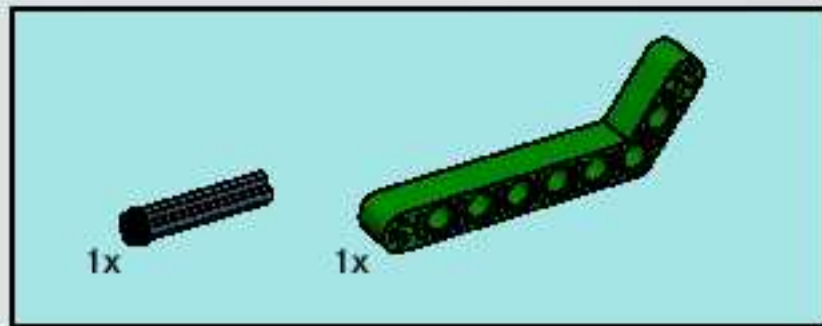
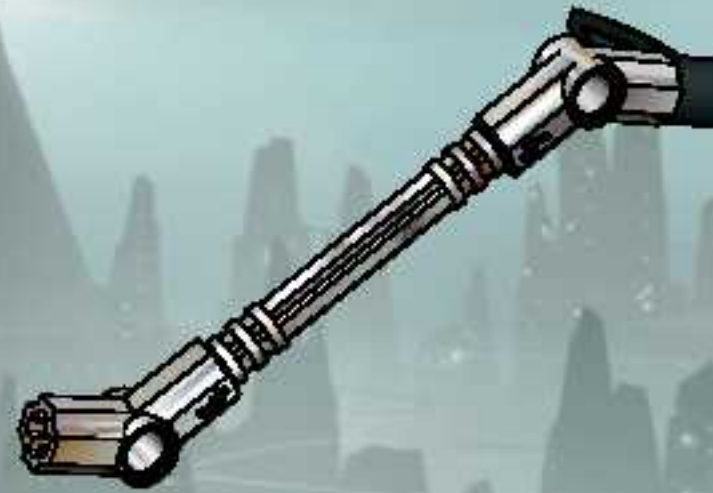

4

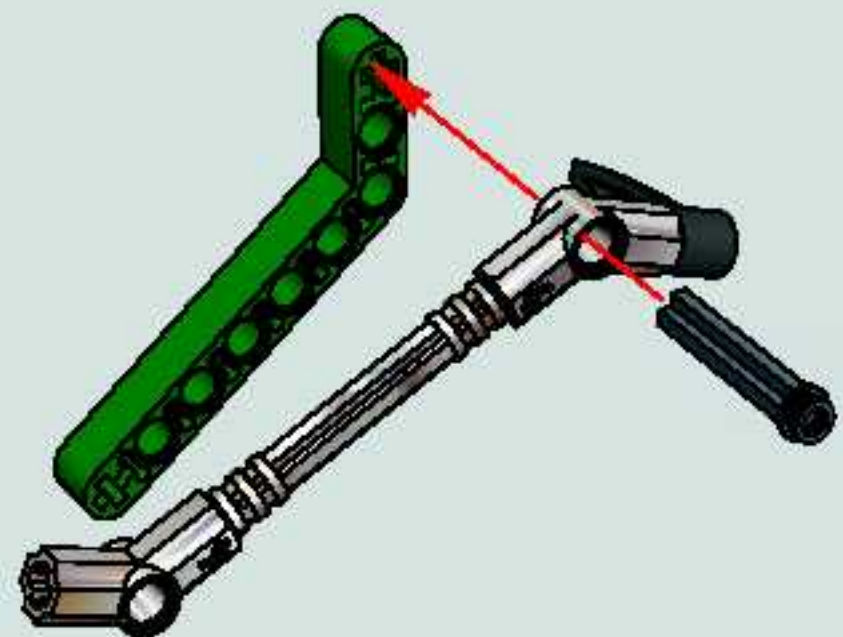

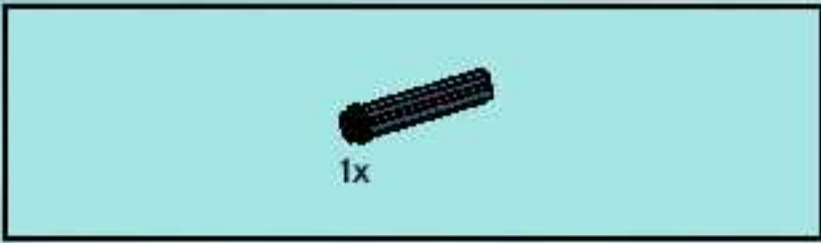

5

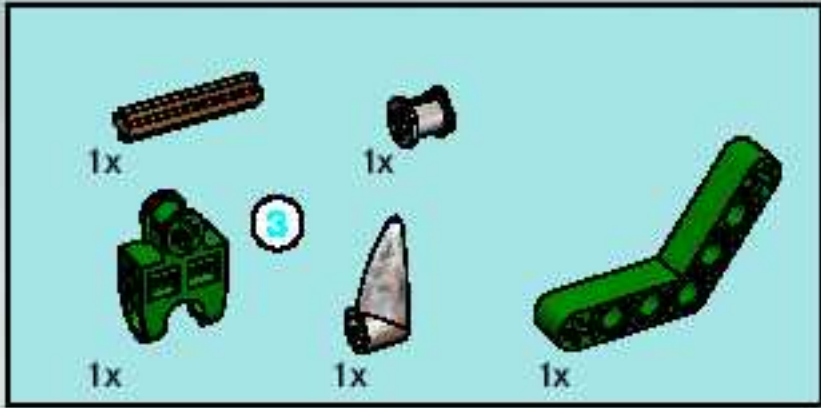

6

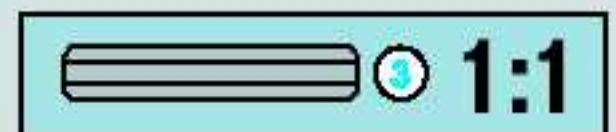
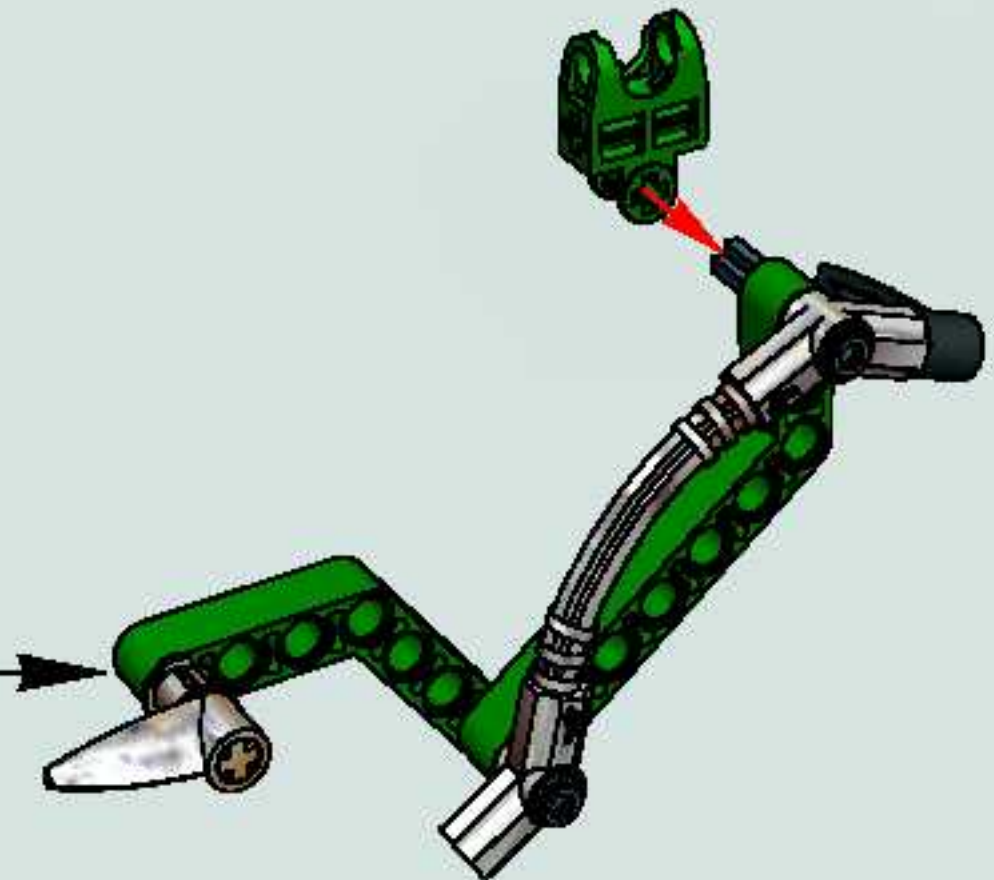
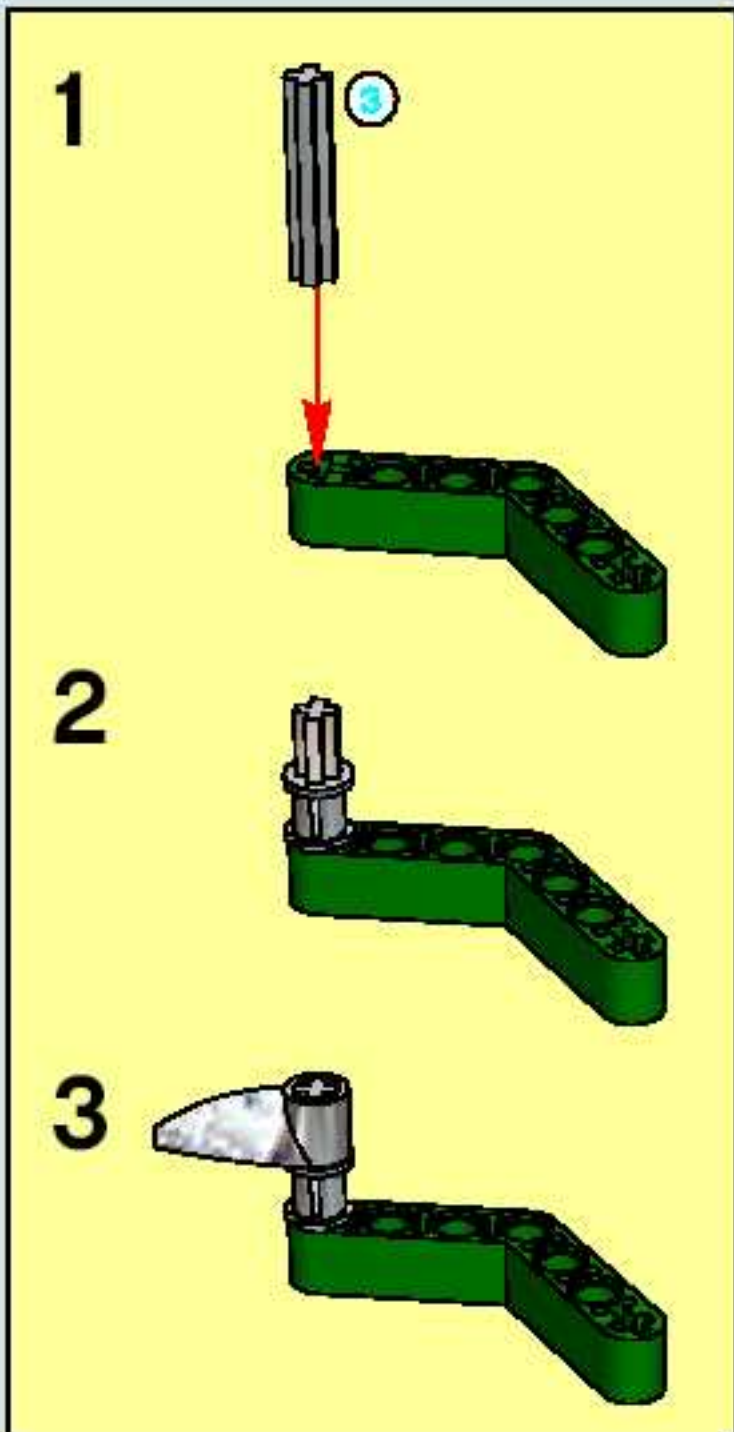

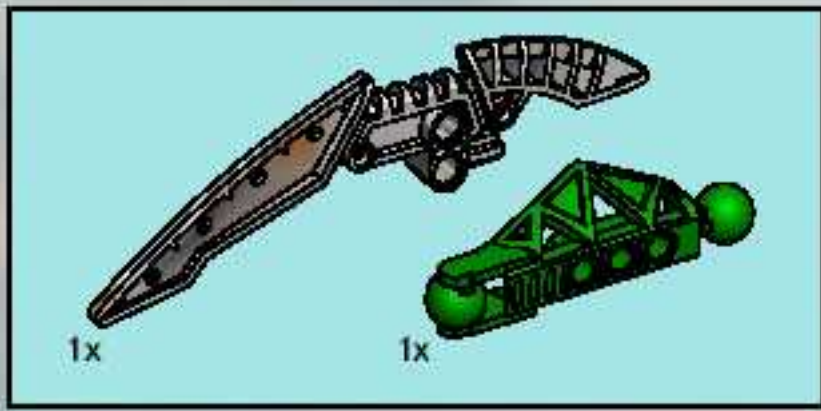

7

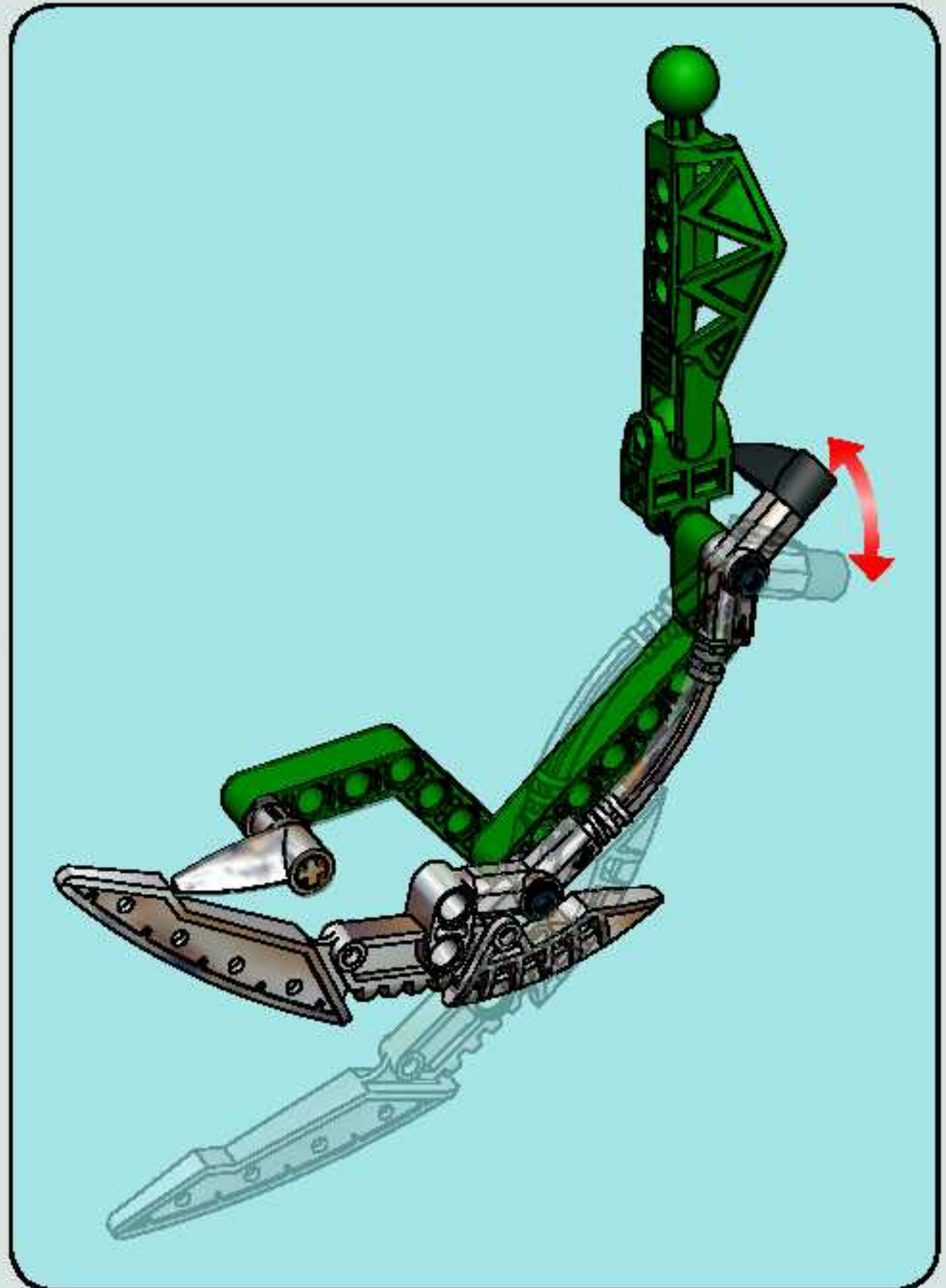
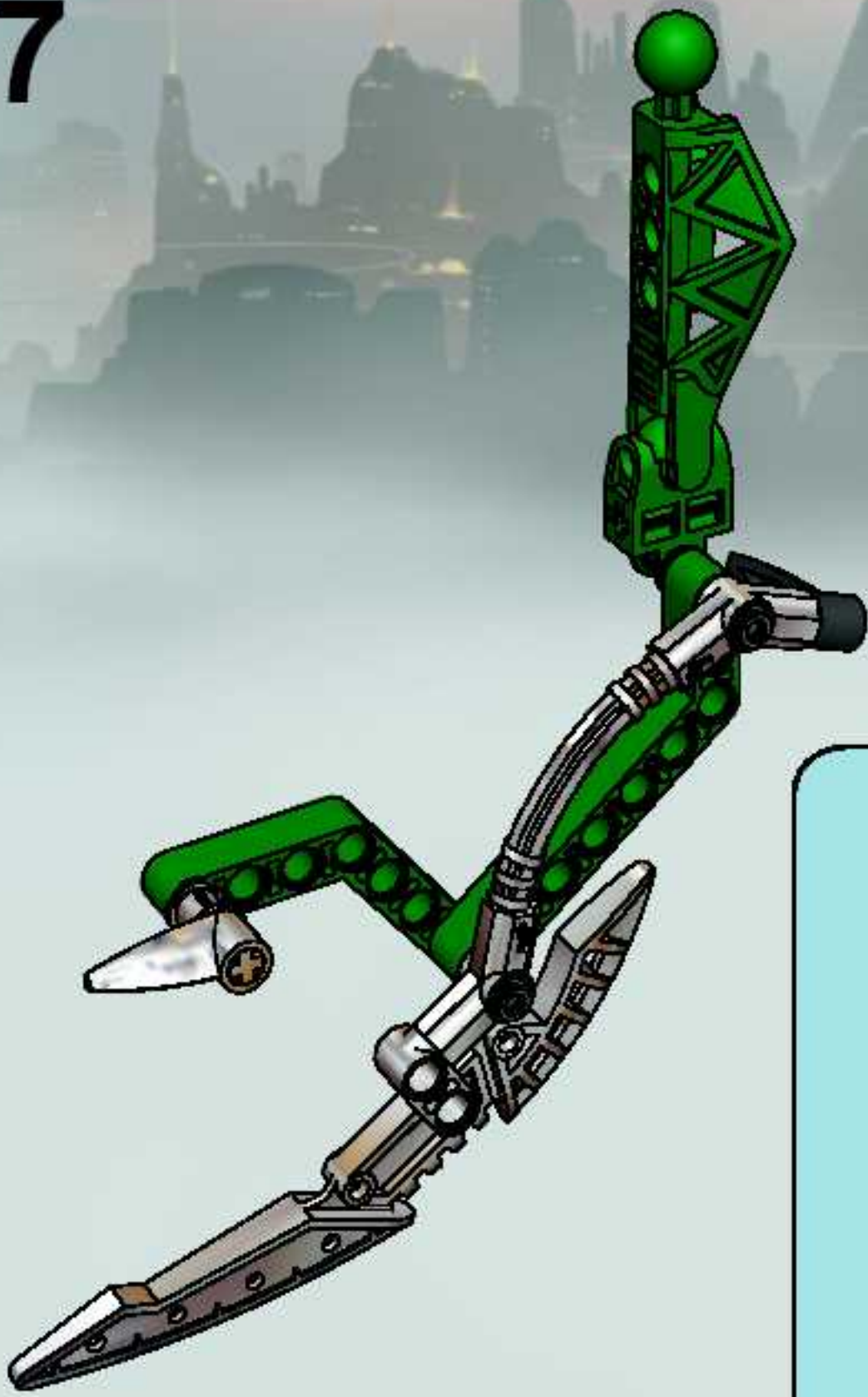

8

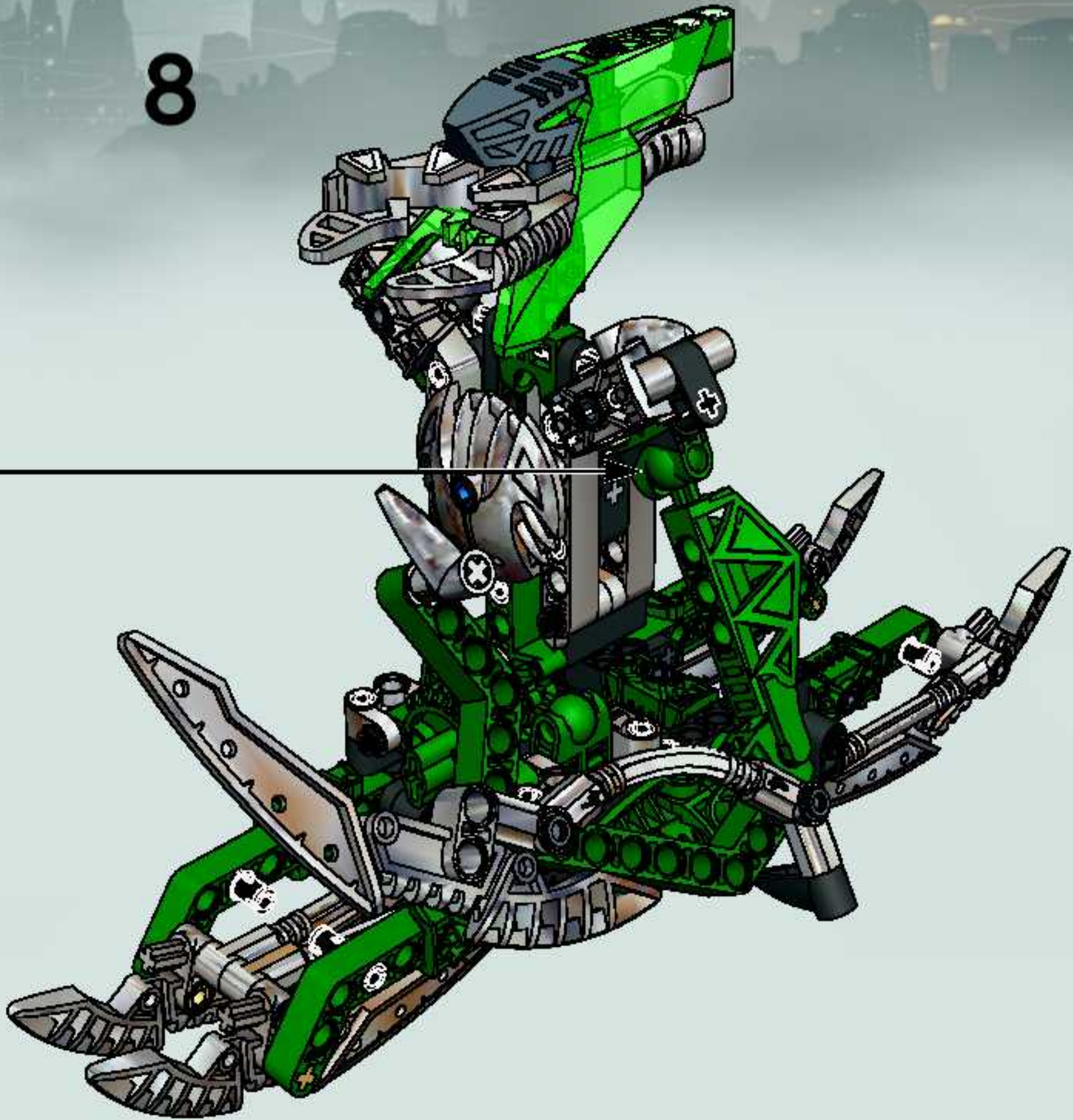

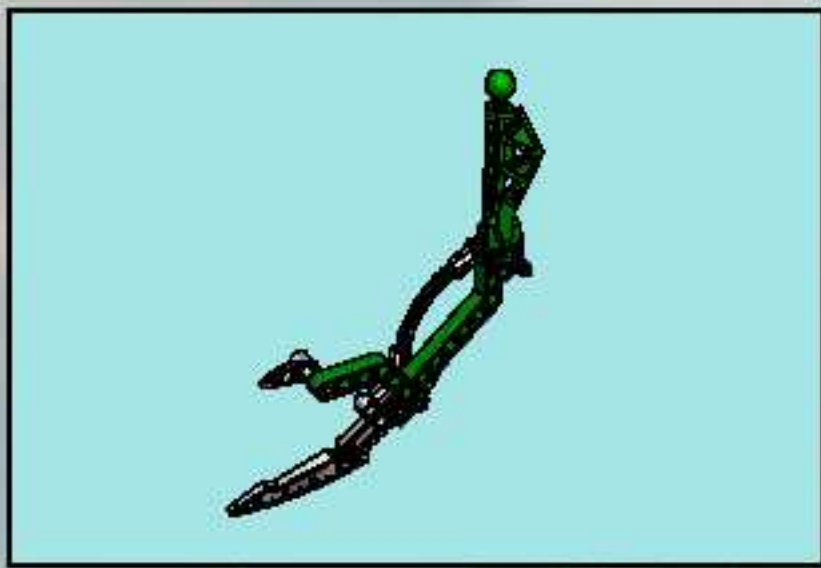

1

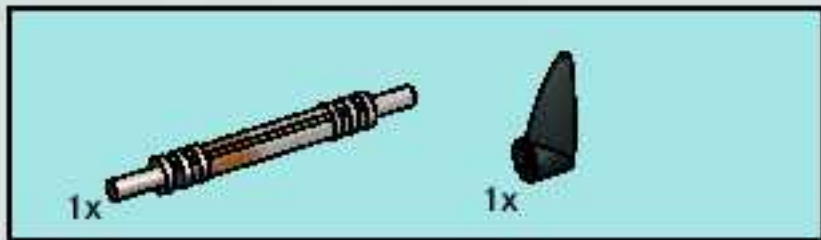
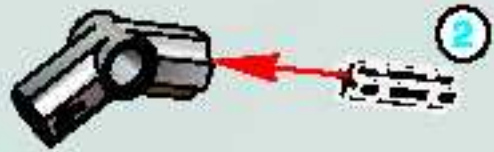

2

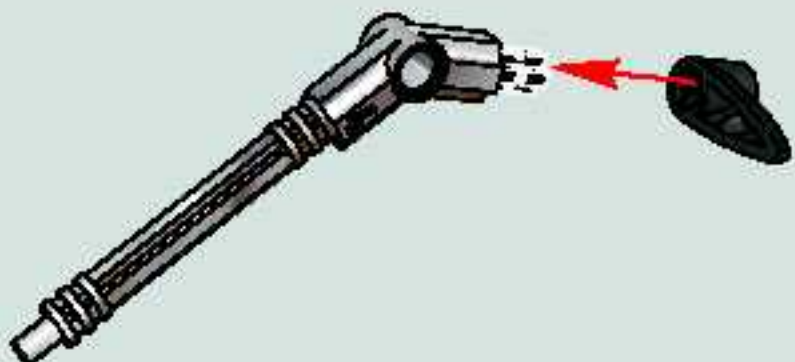

3

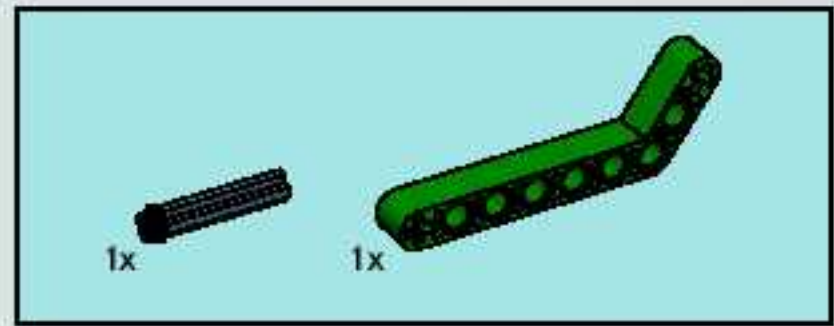

4

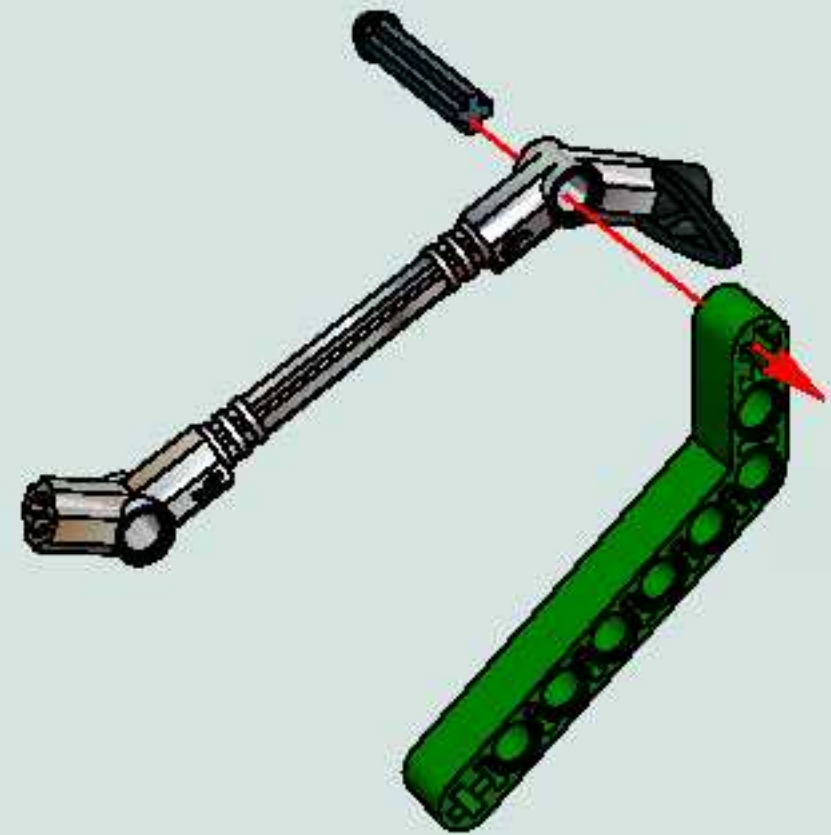

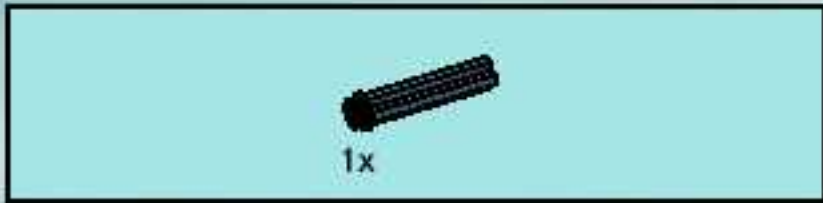

5

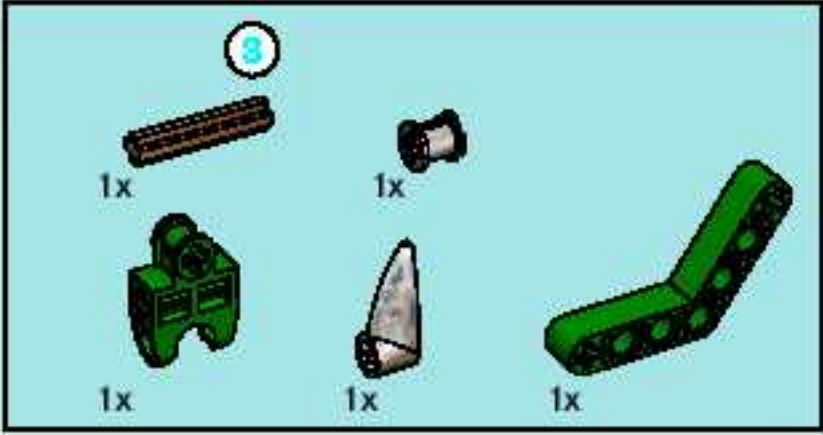
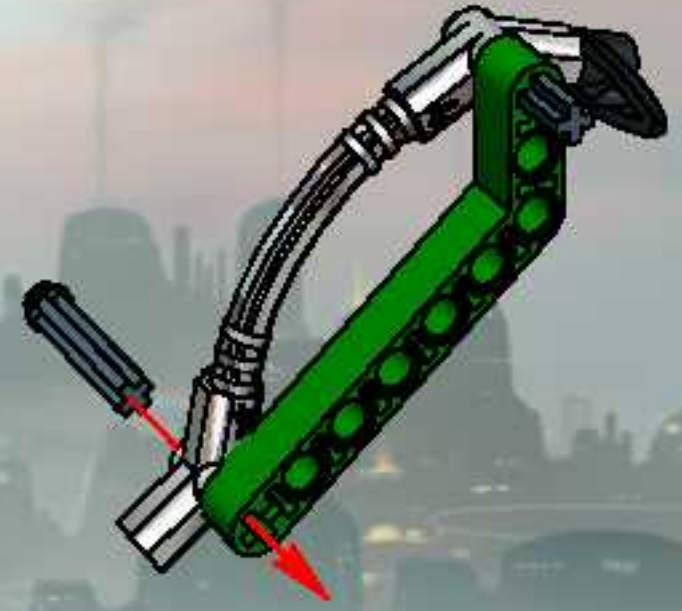

6

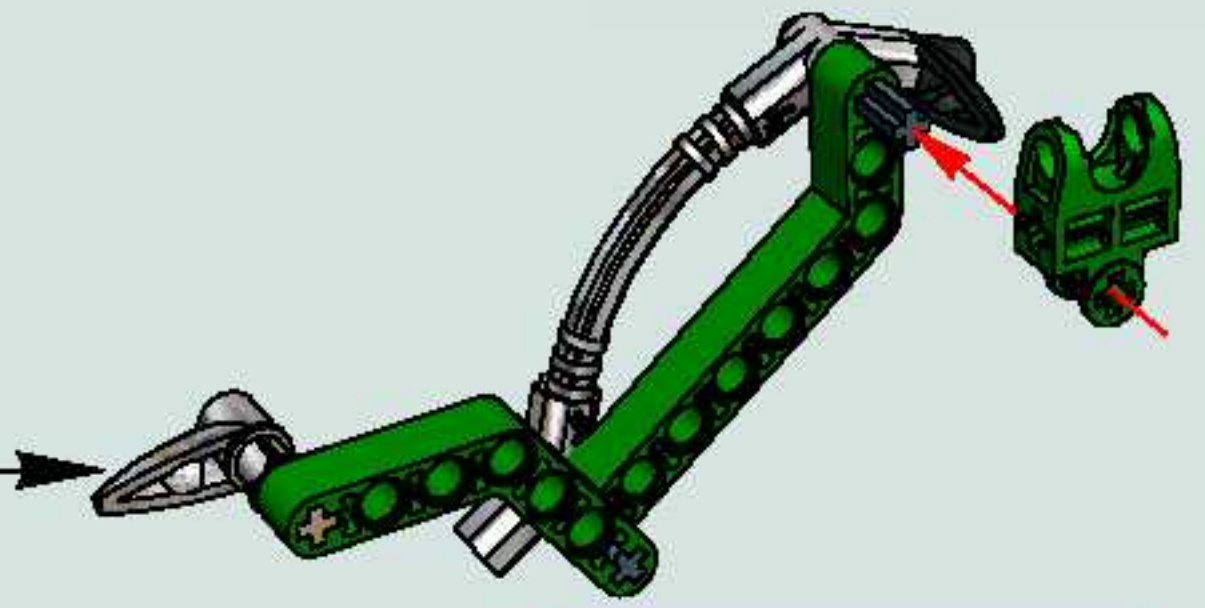
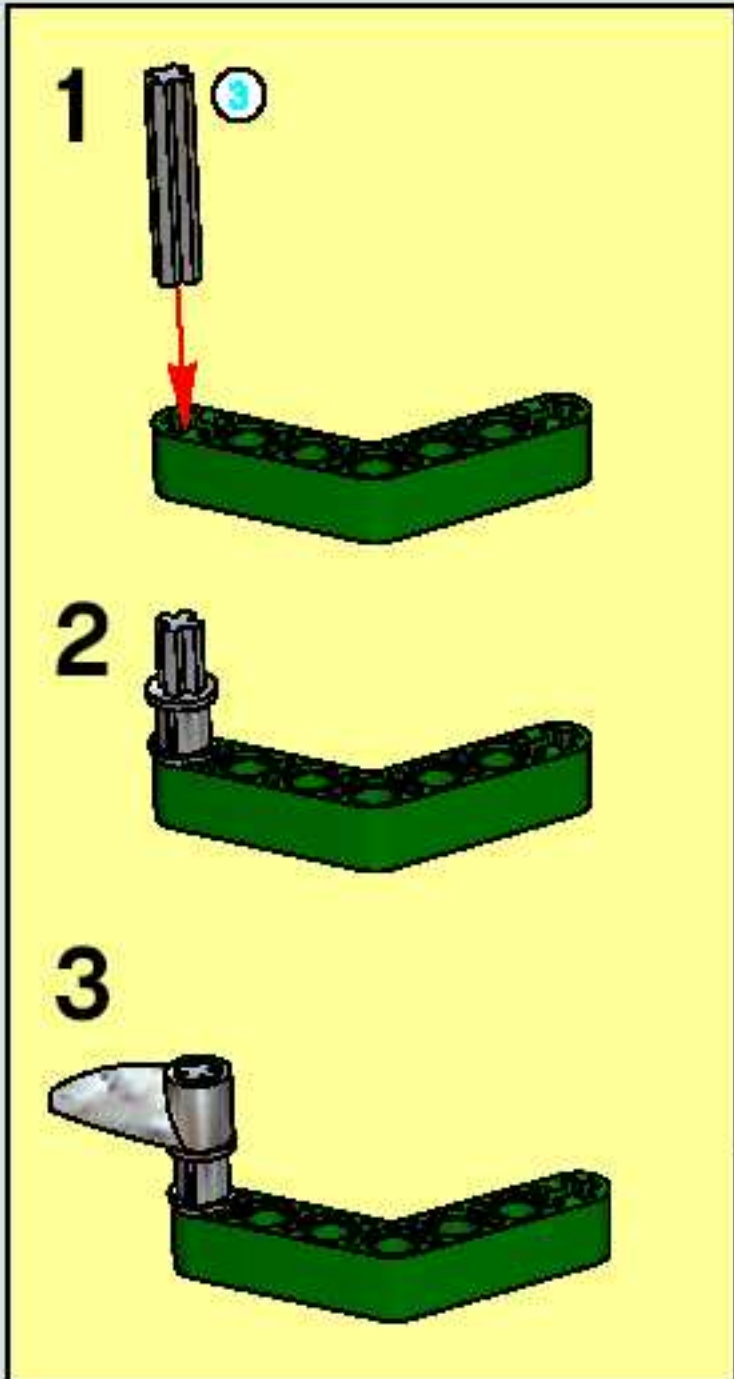

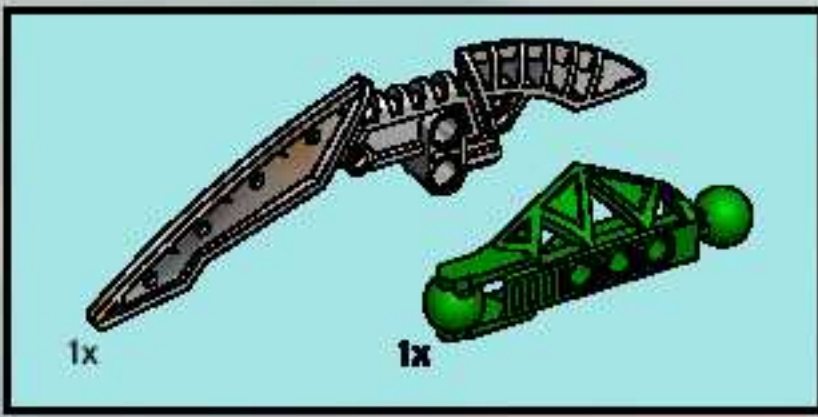

7

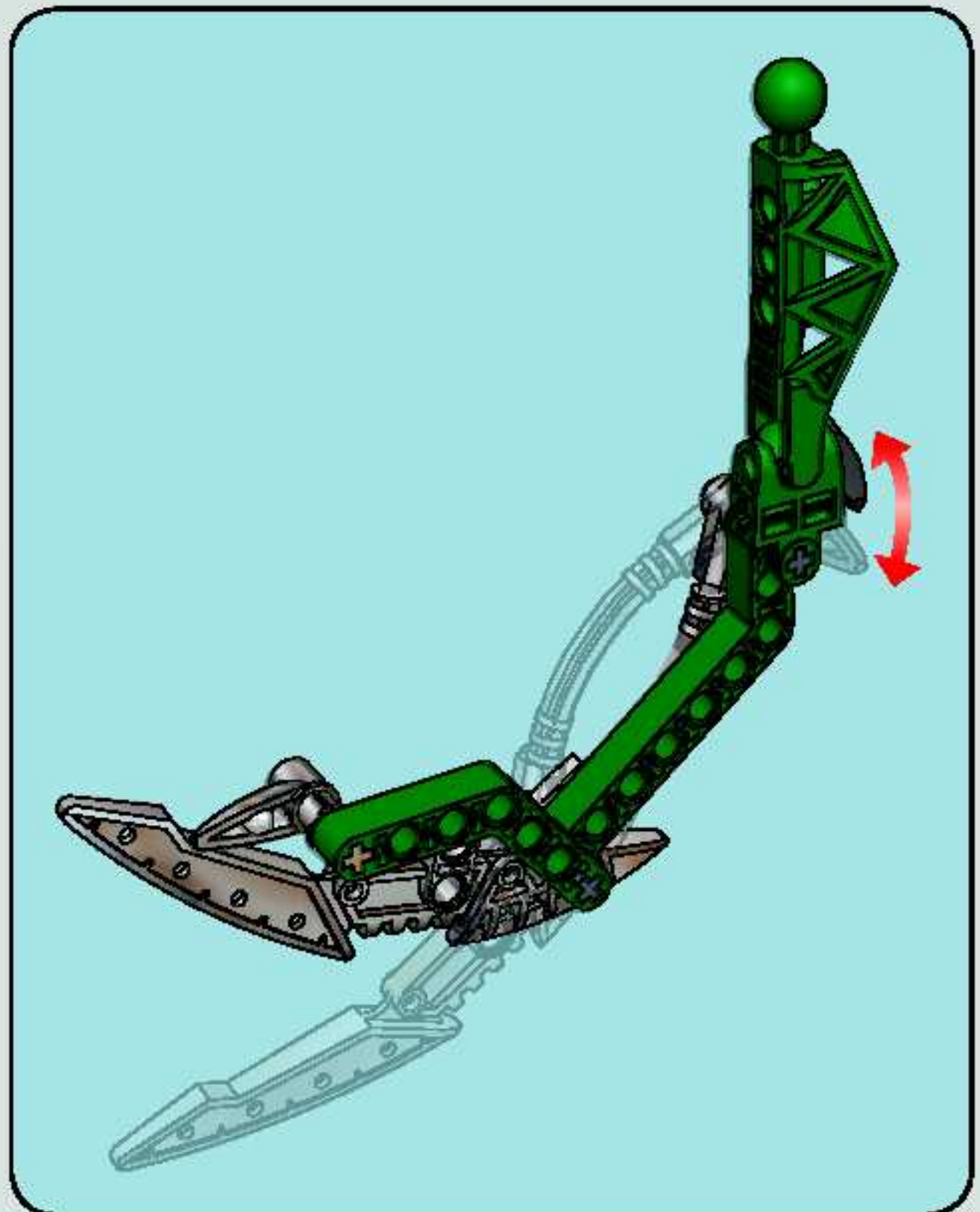
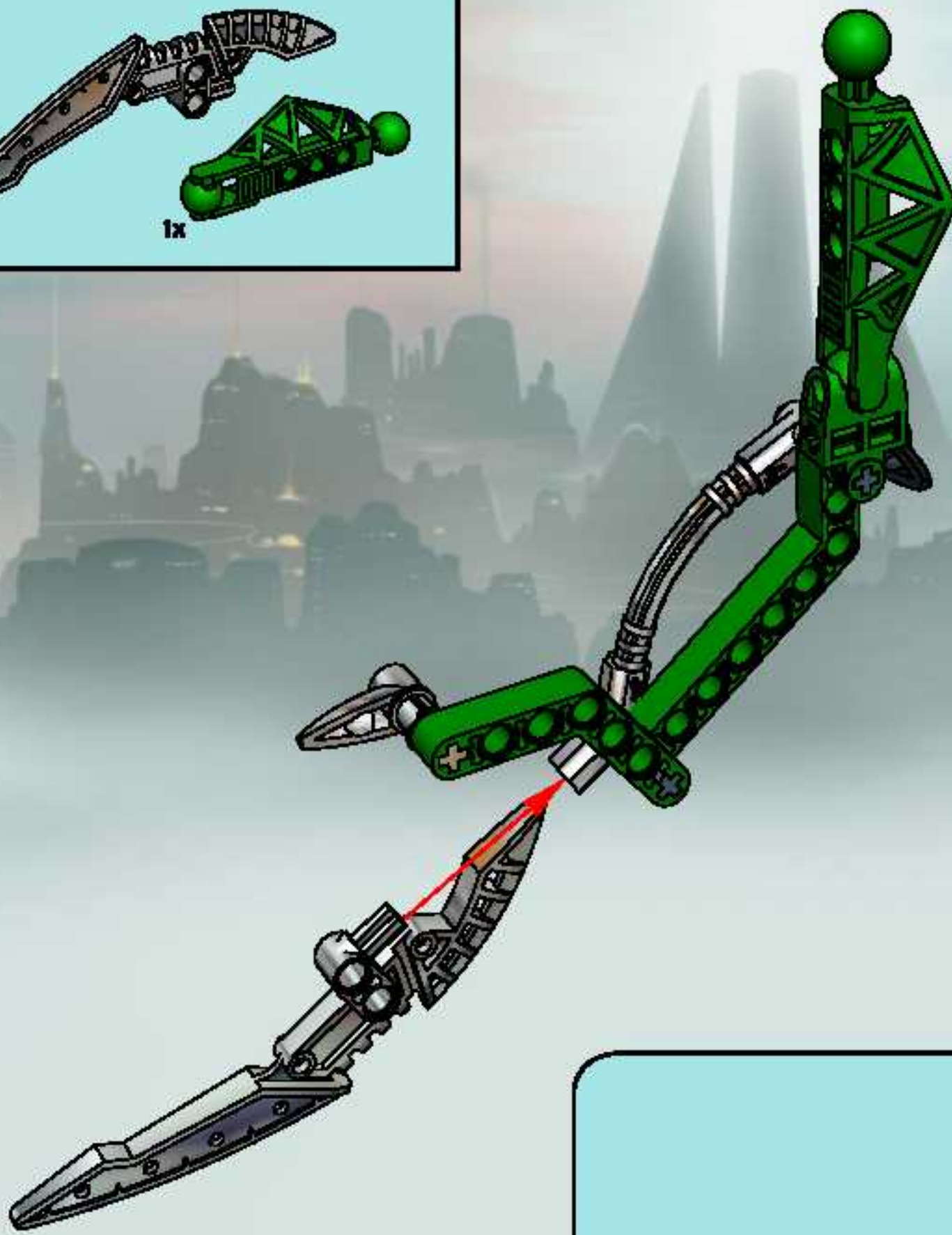

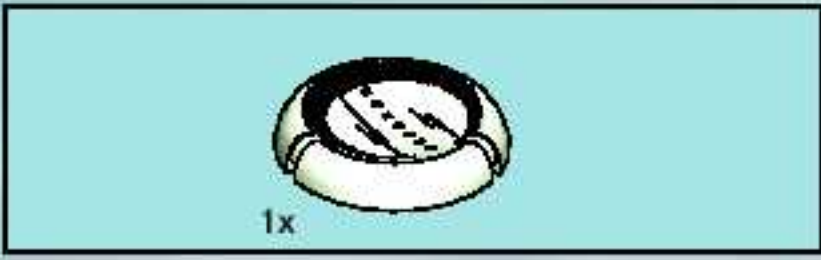

8

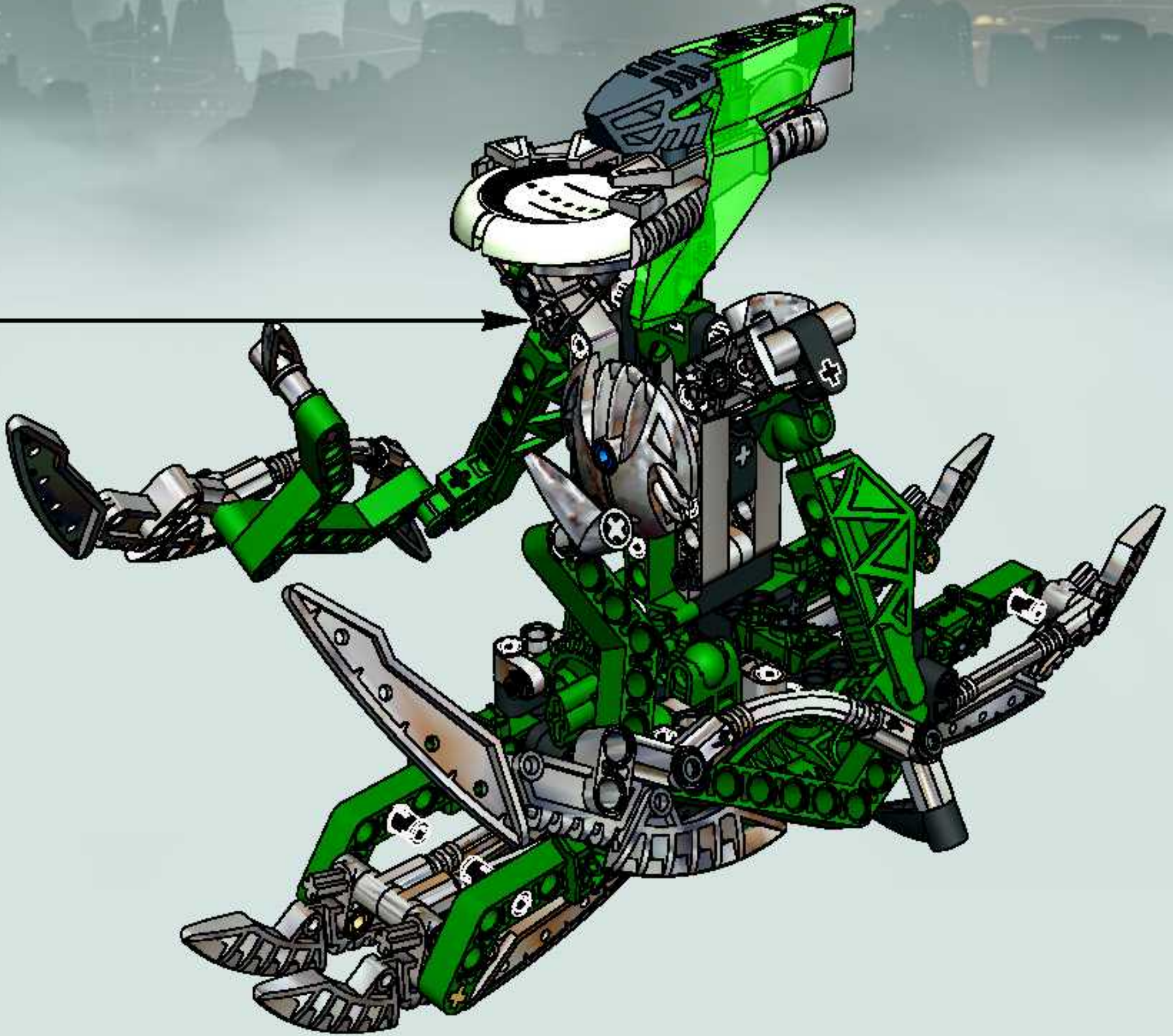

1

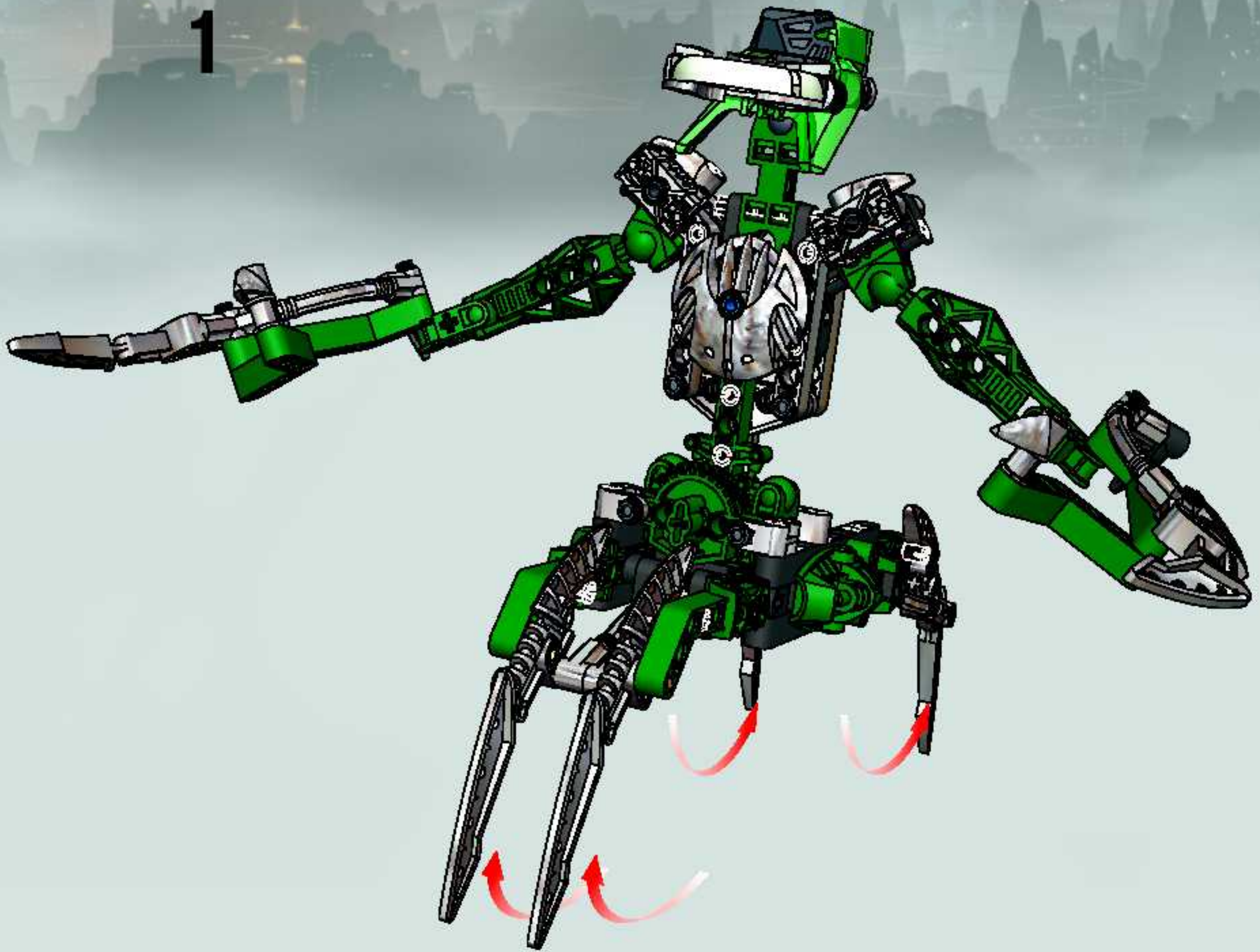

2





8621
TURAGA DUME
& NIVAWK



8623
KREKKA



8621

+



8622

+



8623

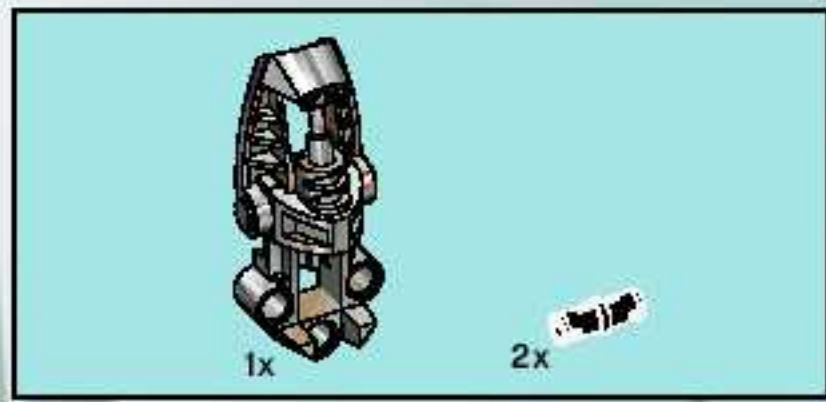
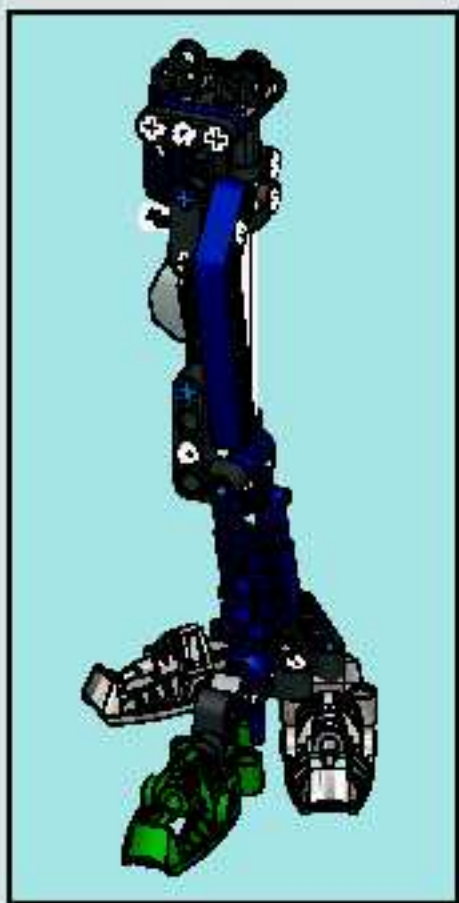
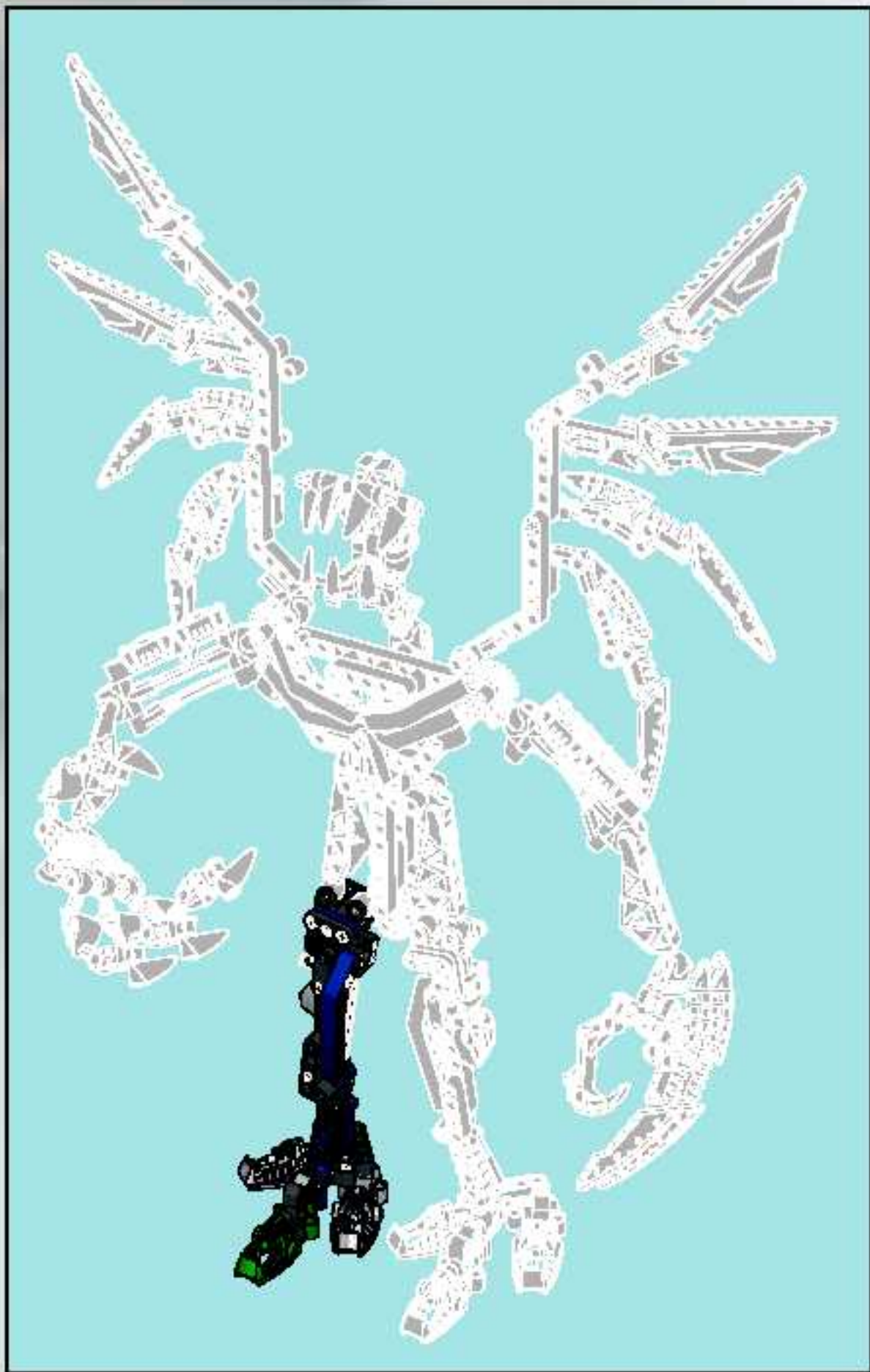

1

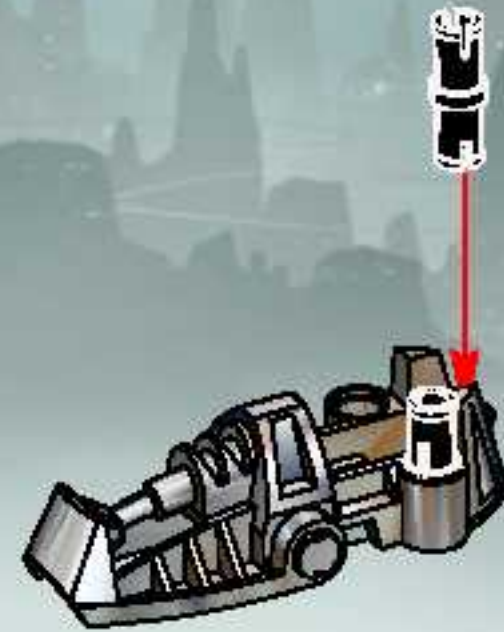

2

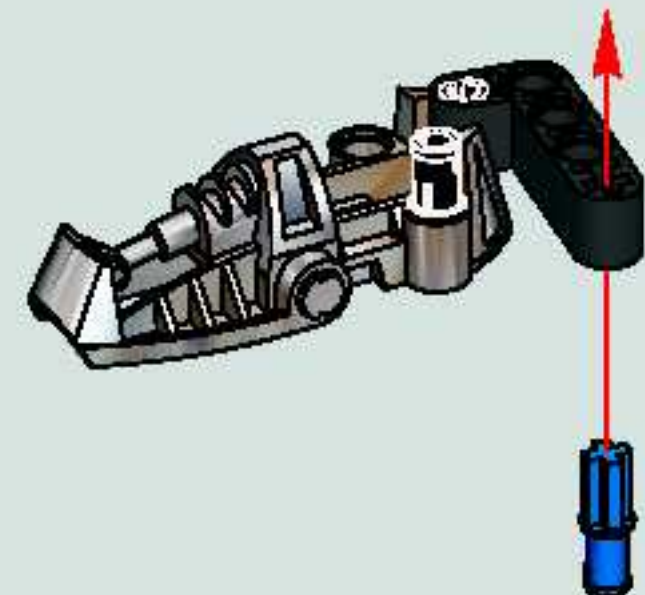

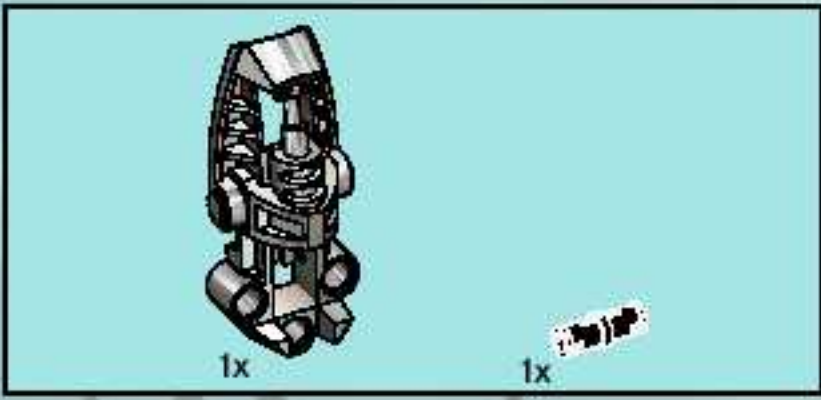

3

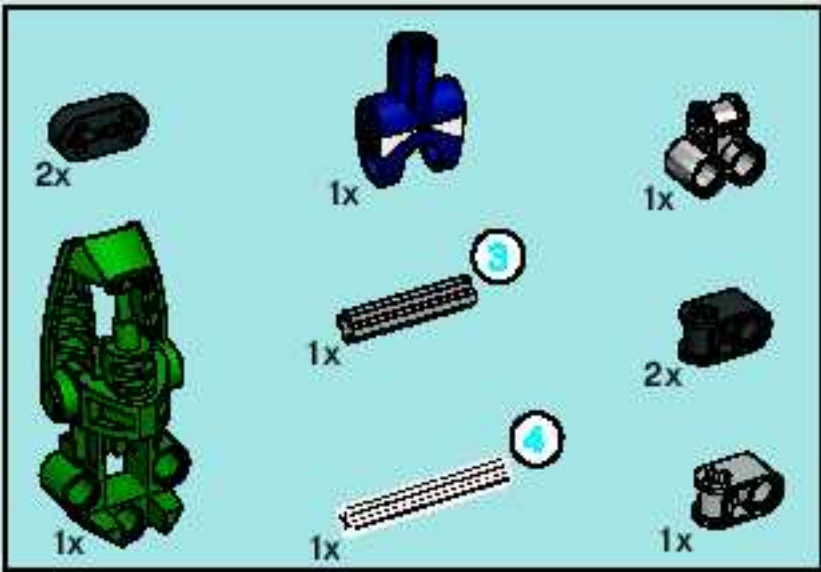
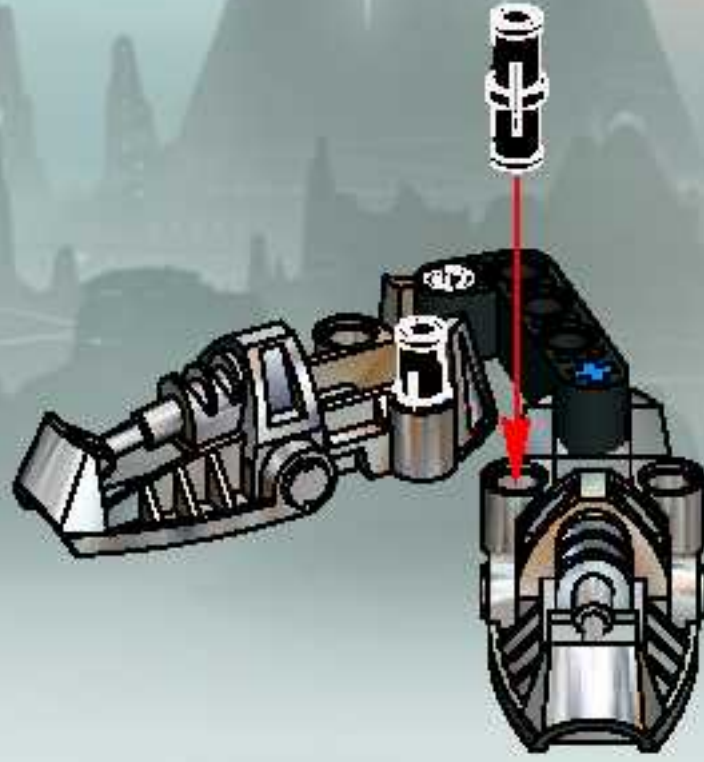

4

1

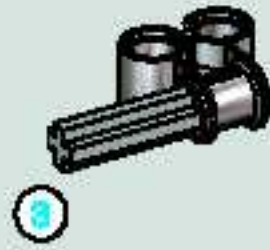

2



3

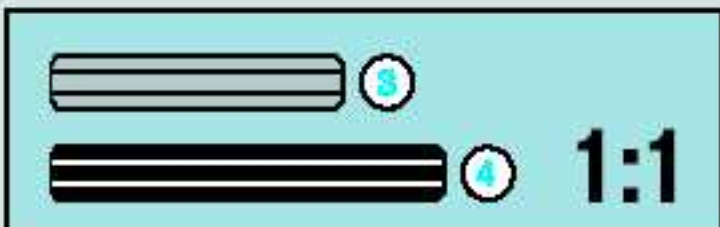

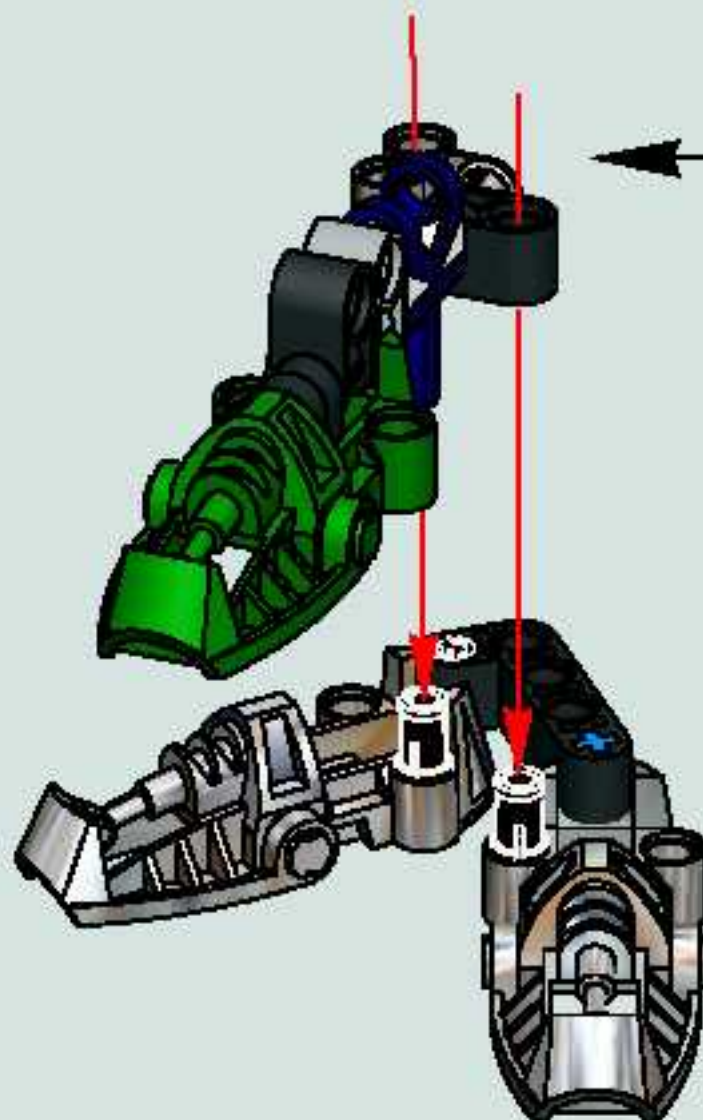
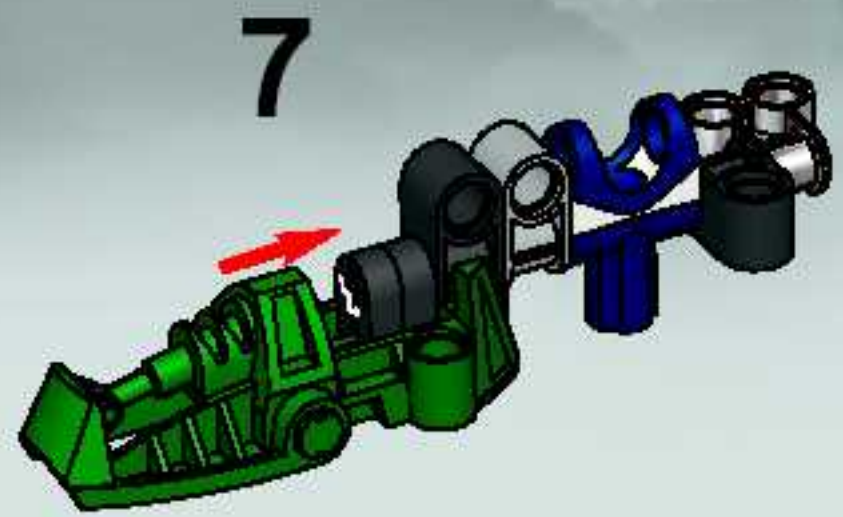
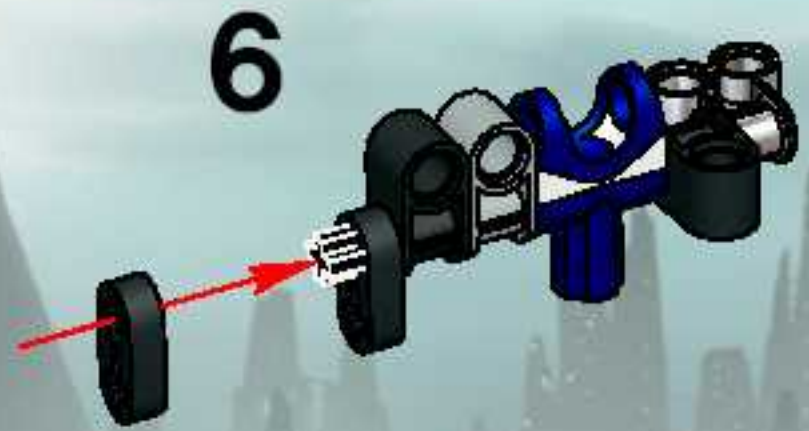
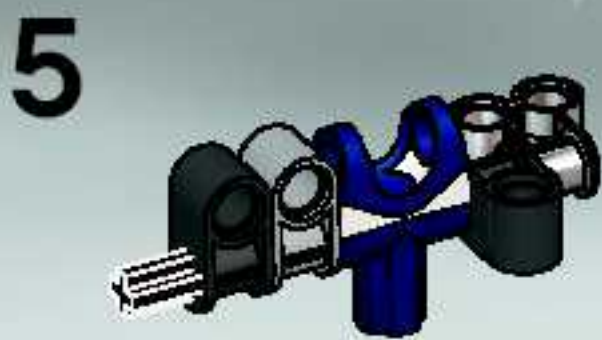
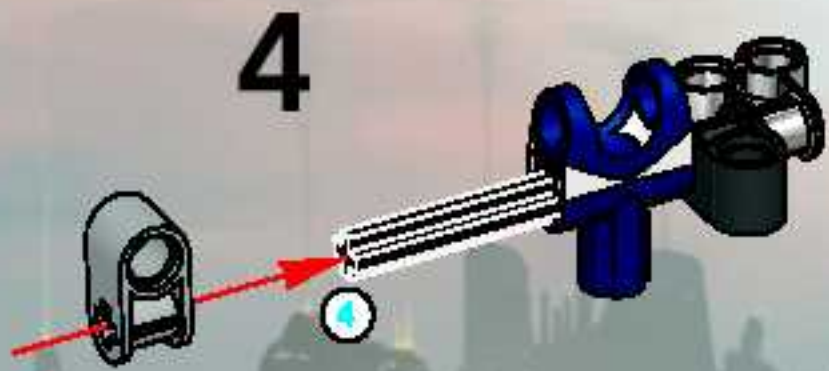

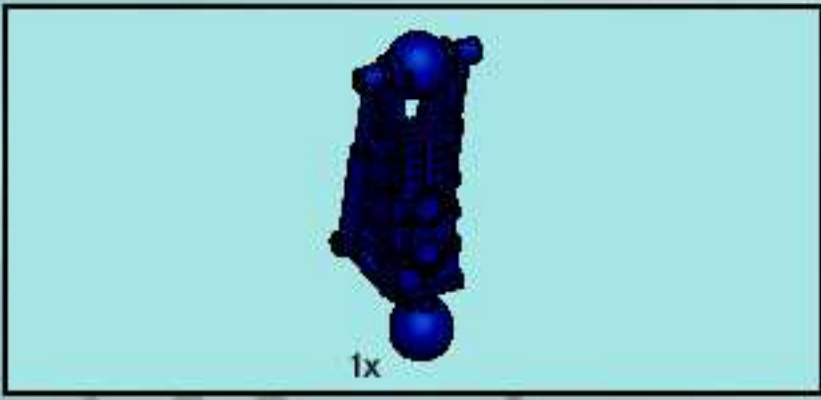

5

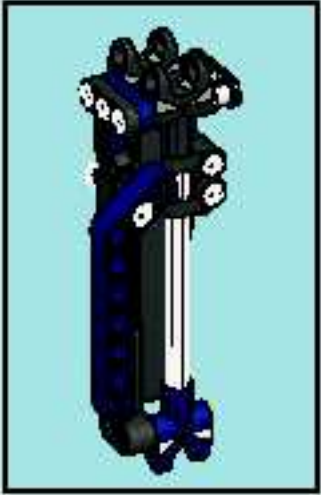

1



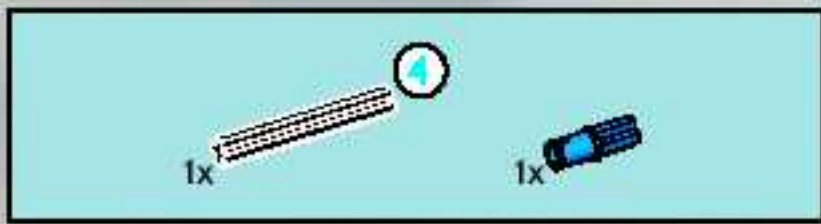

2

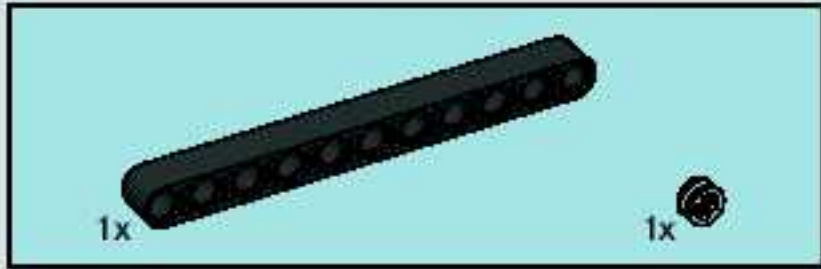
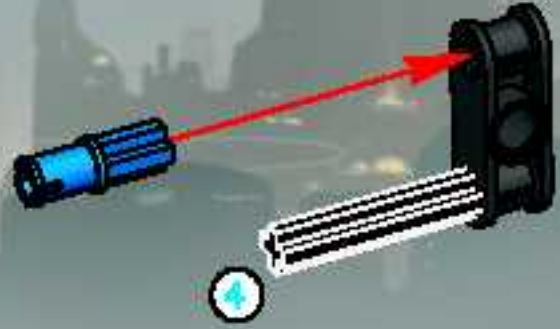

3

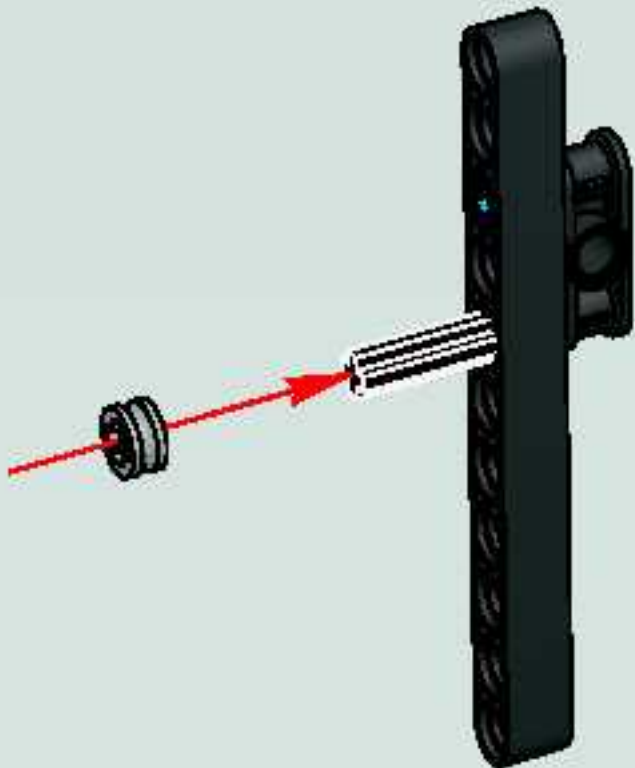

4

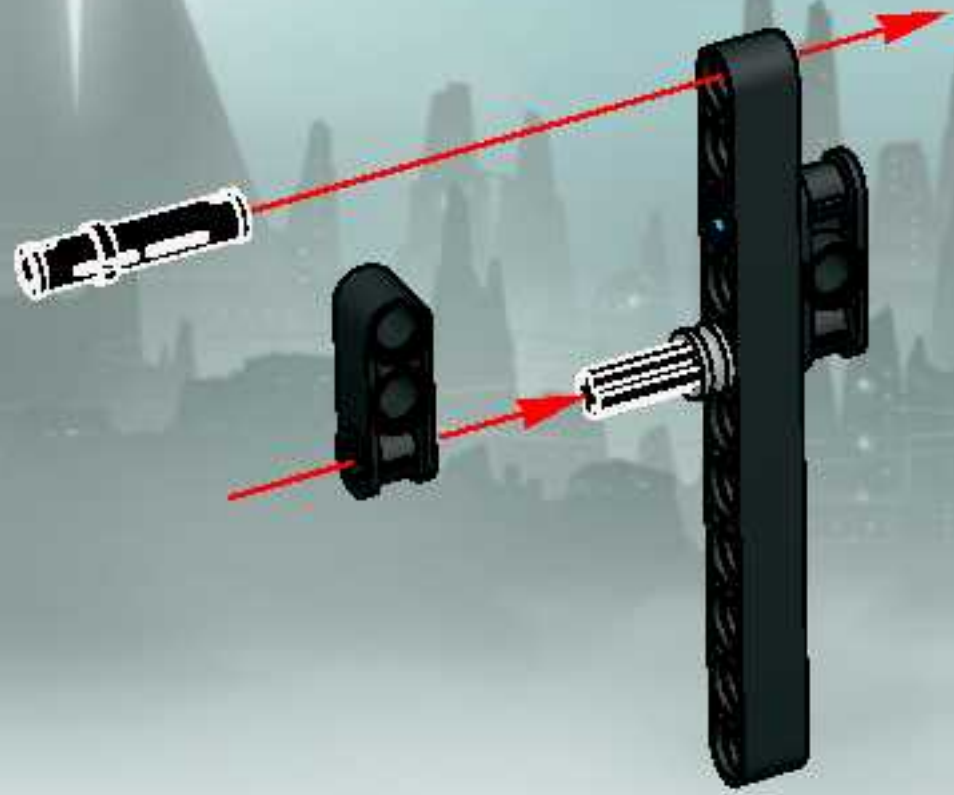

5

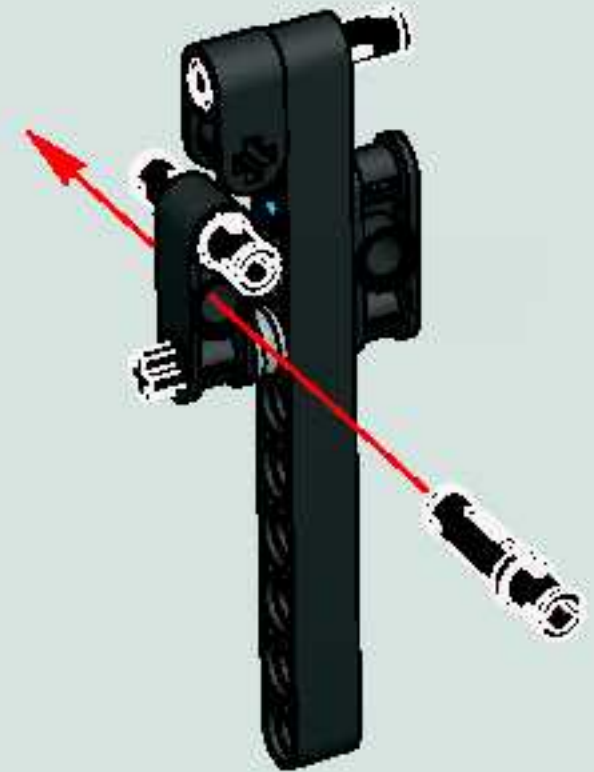

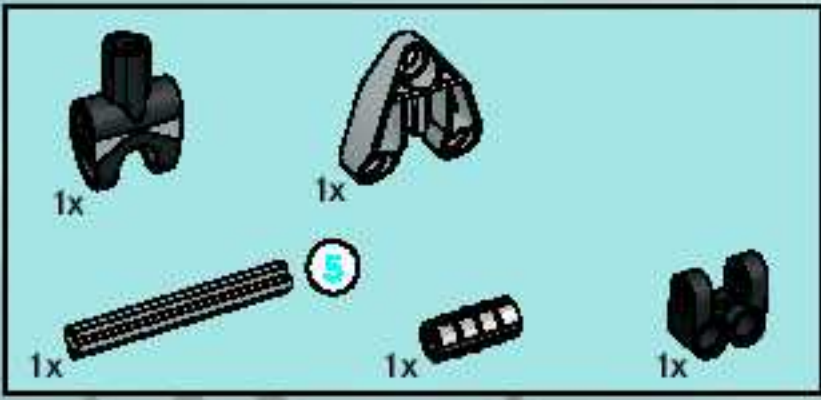

6

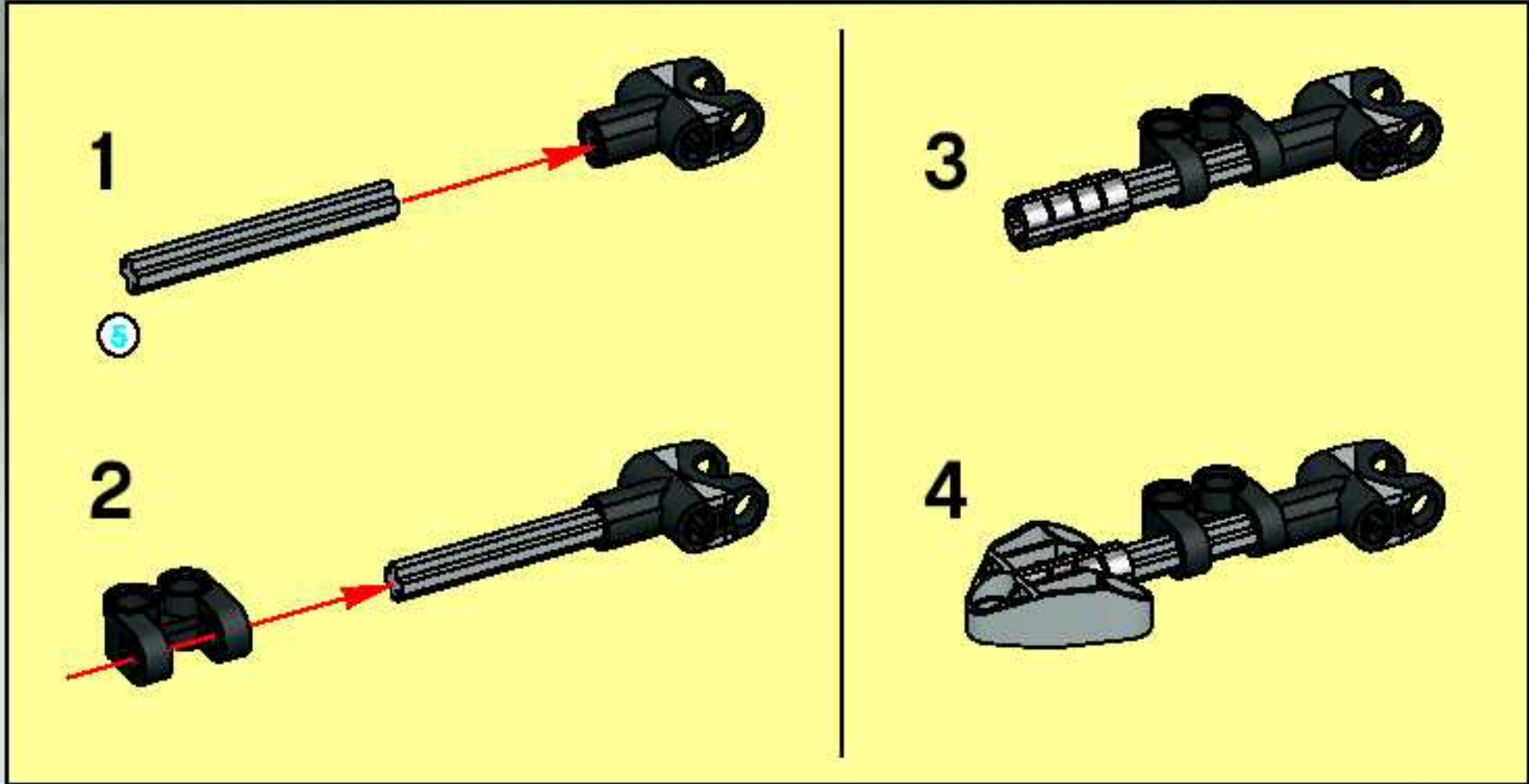

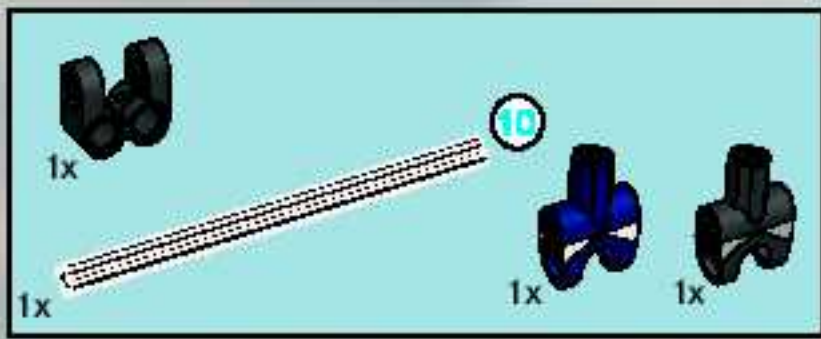

7

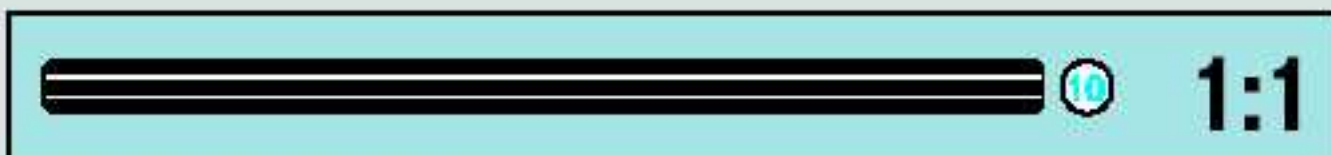
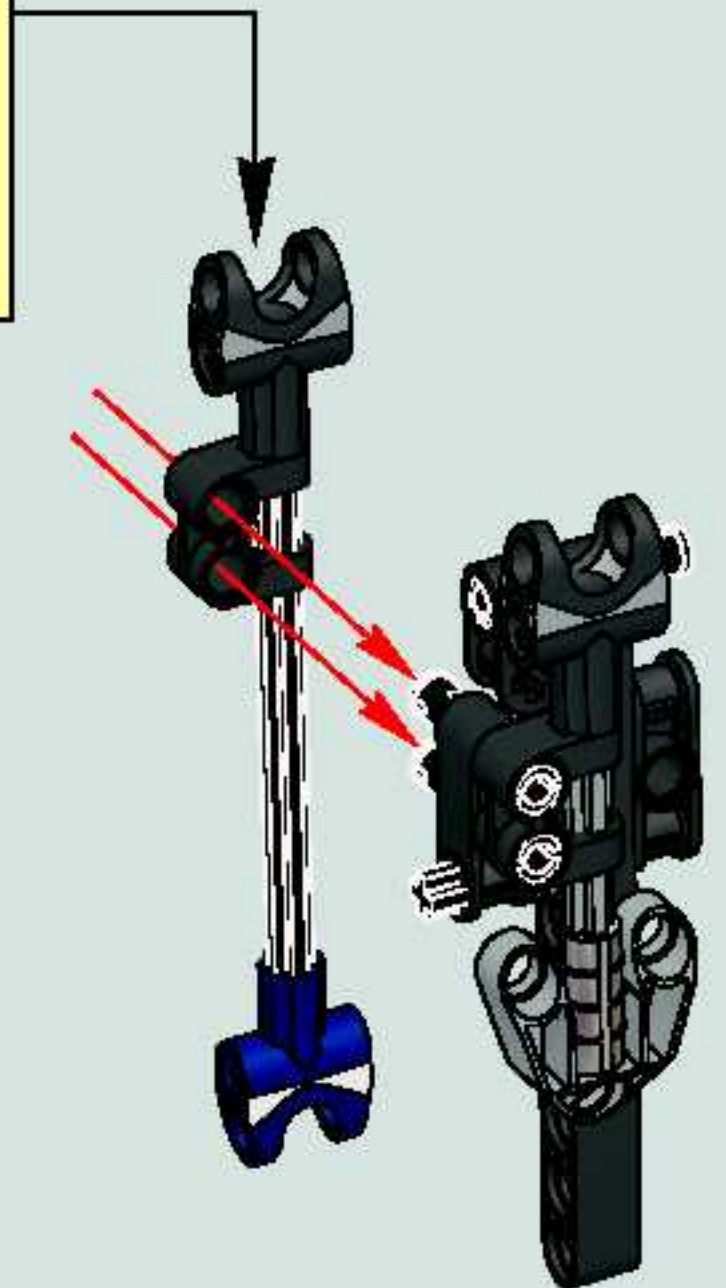
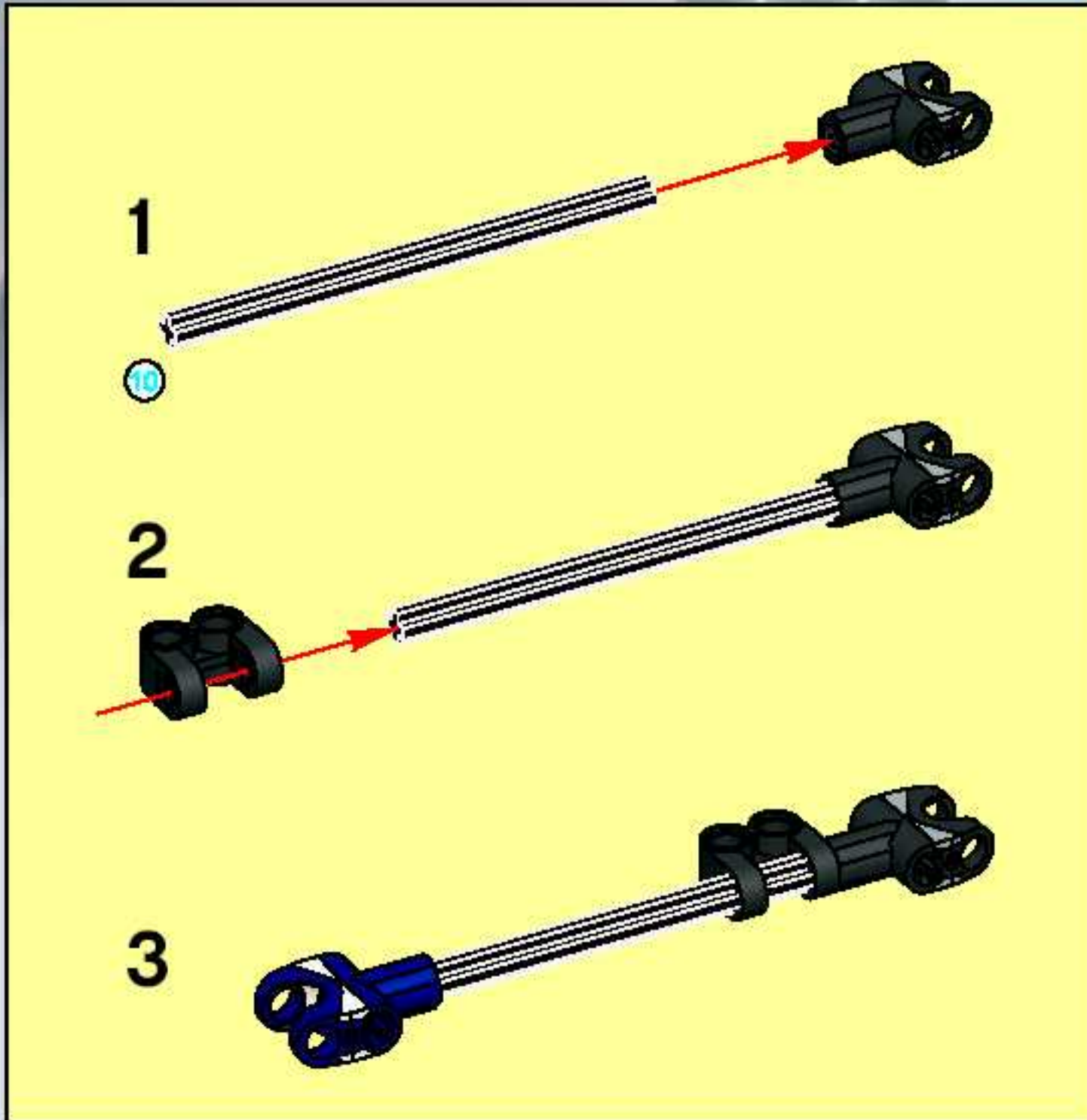



8

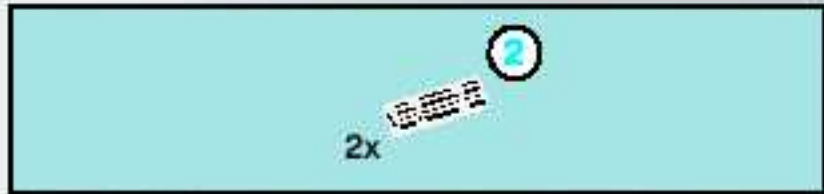

10

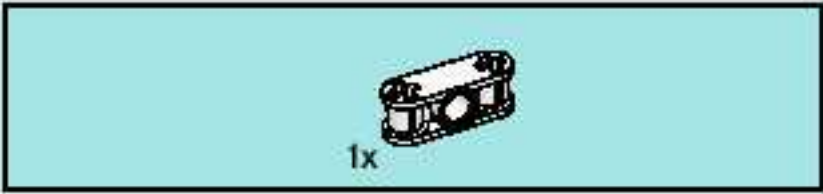

9

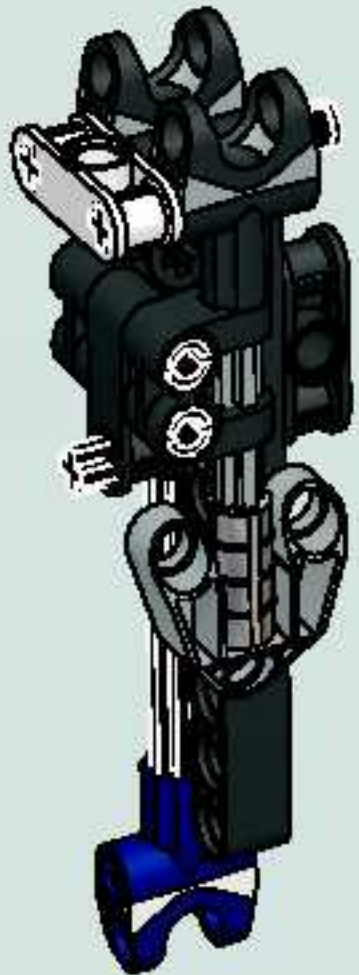

11

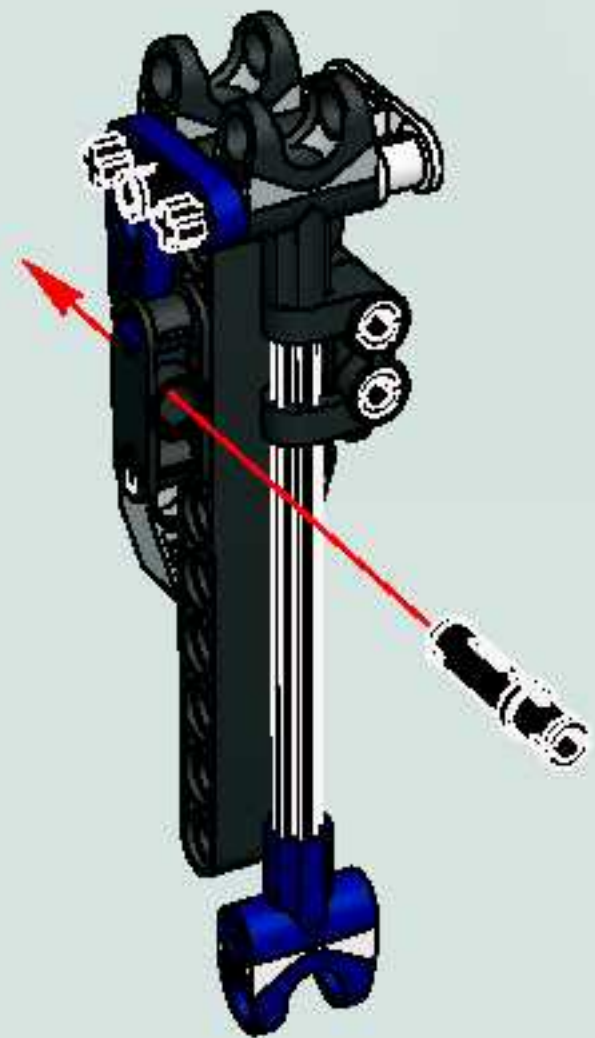



12

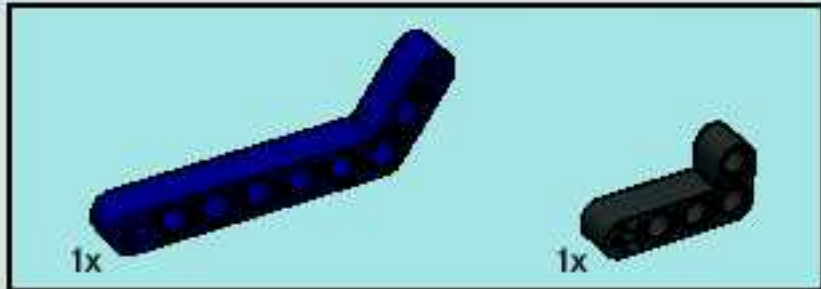
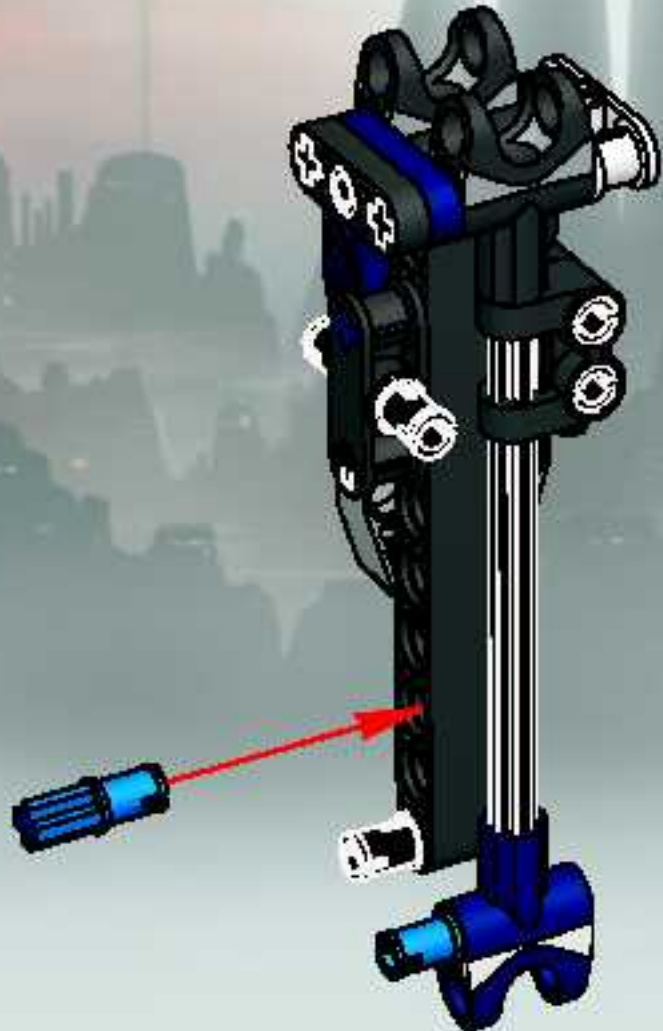

13

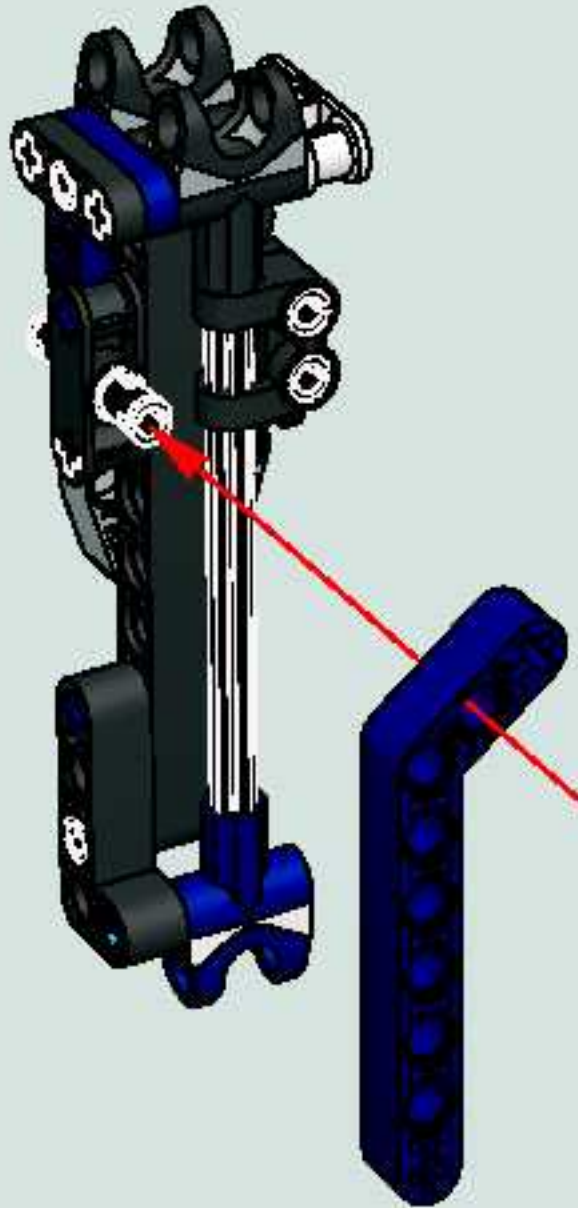

6

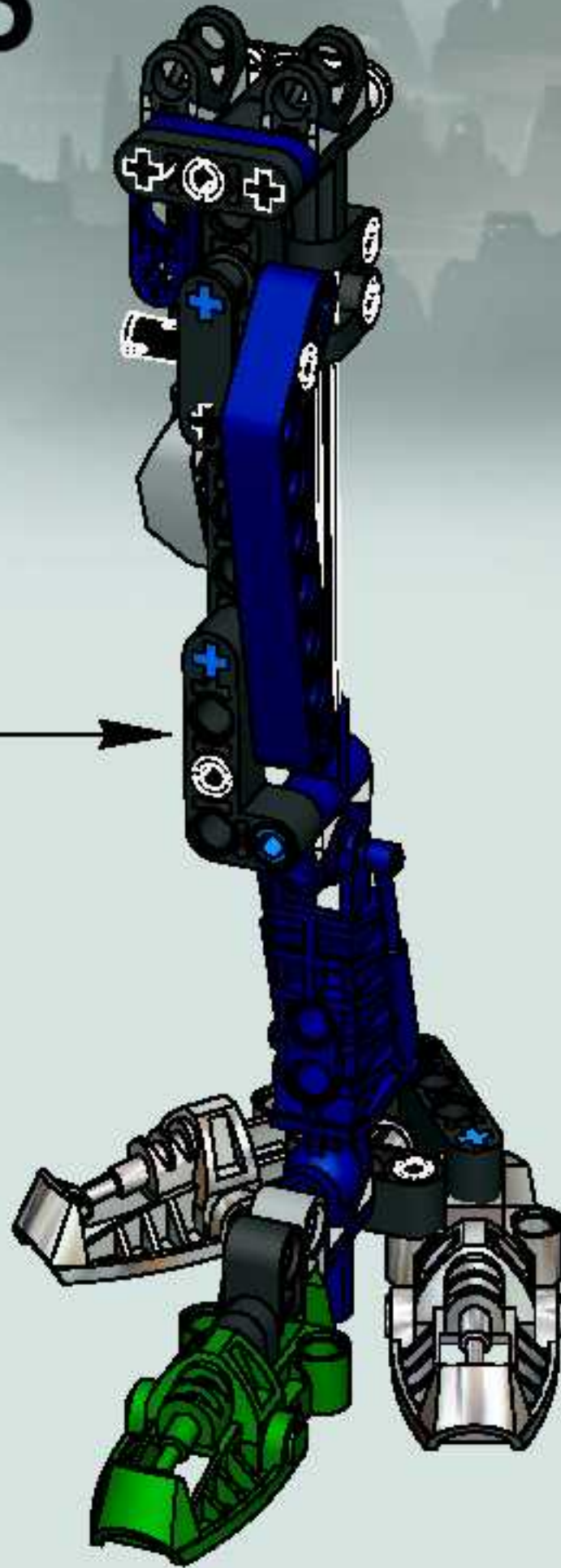

16



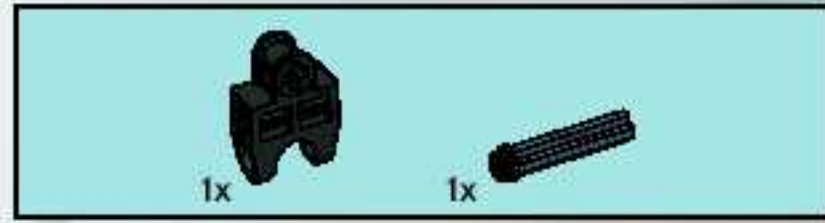
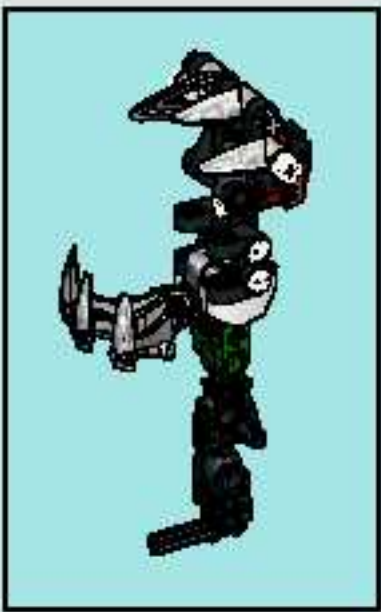
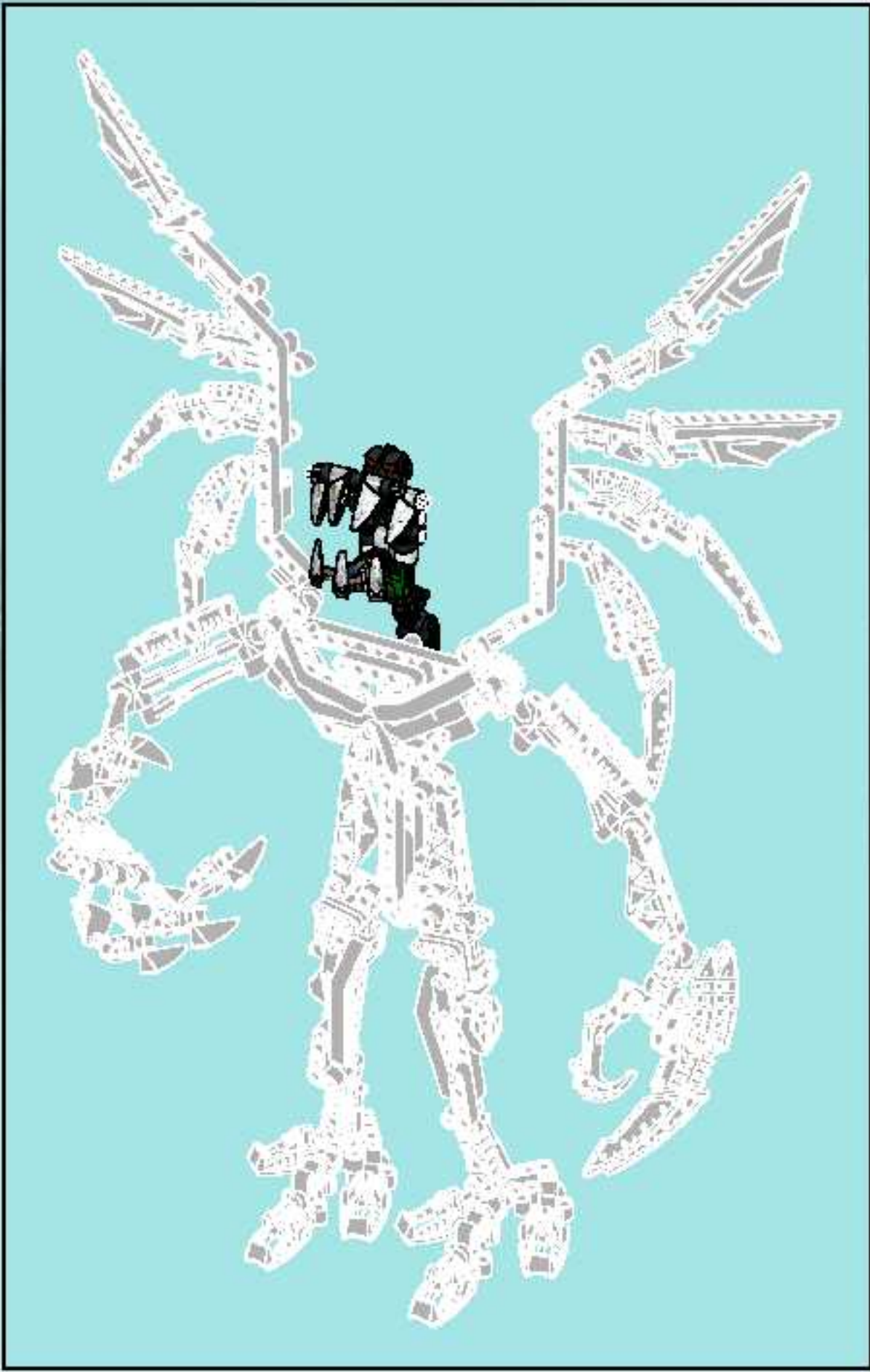

1

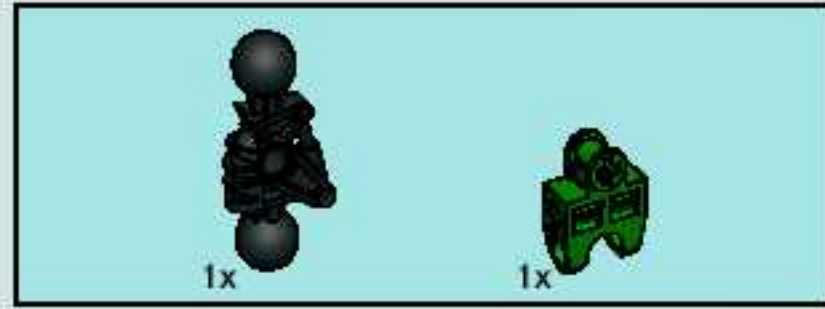

2





3



4



5



6





7



8

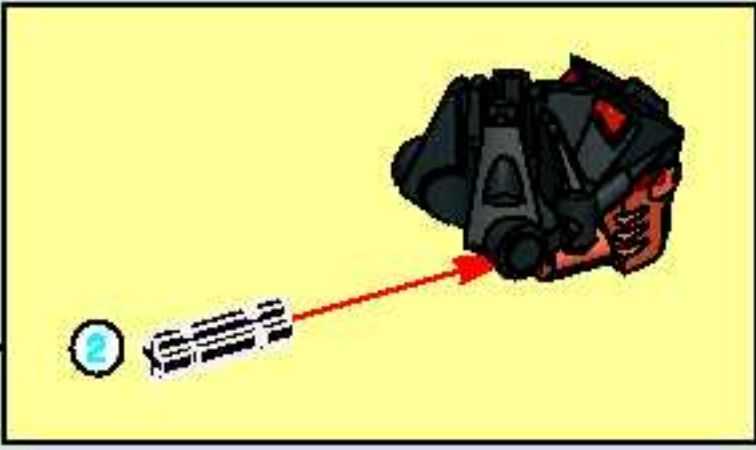

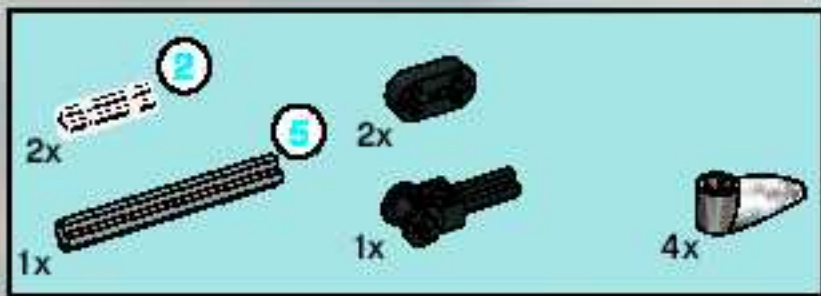

9

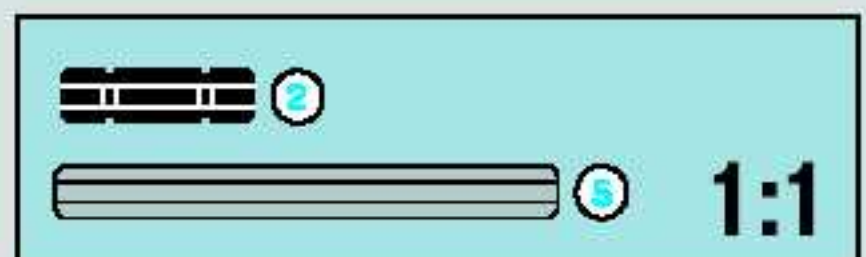
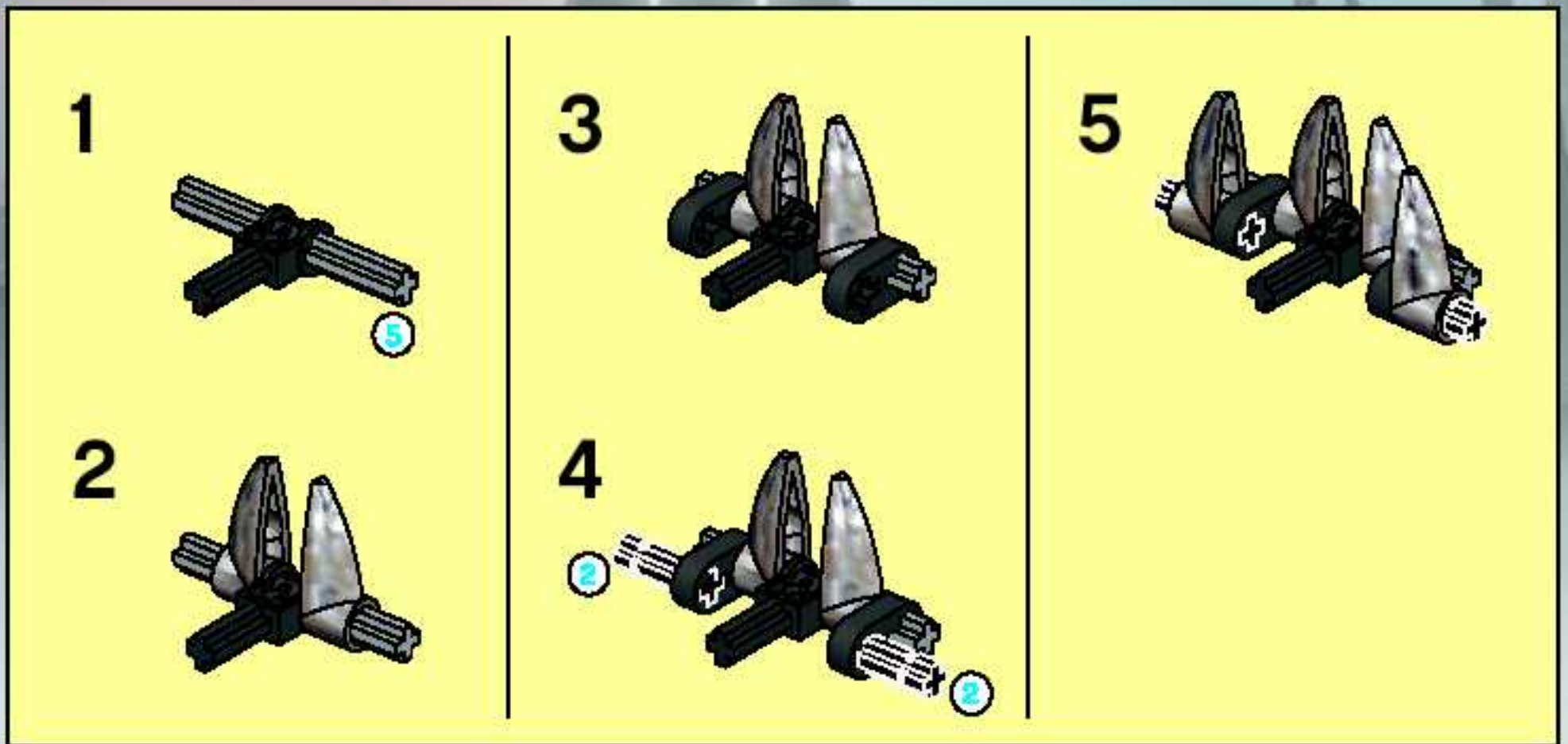

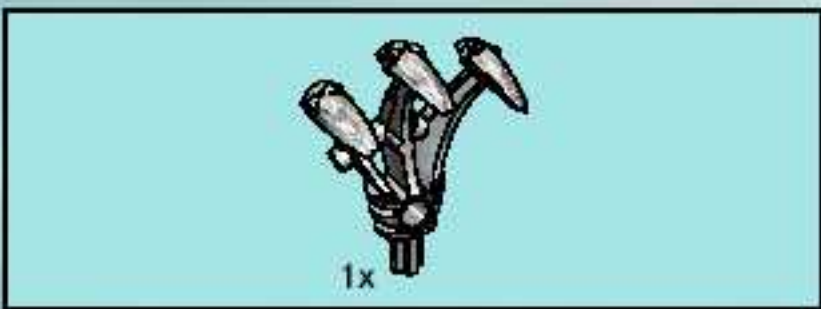

10



17

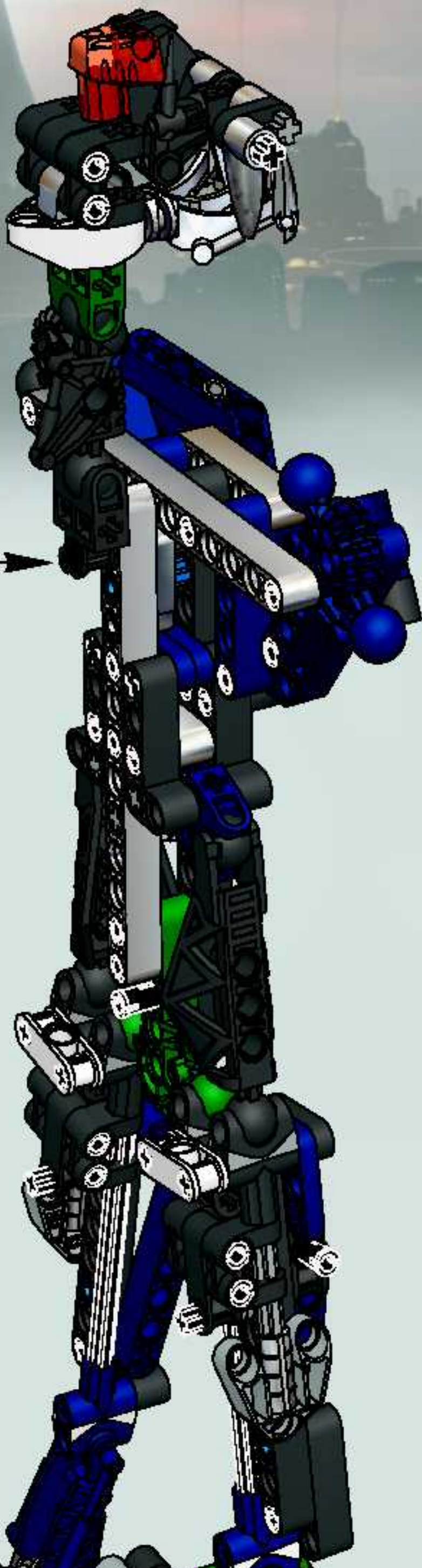

BIONICLE

www.bionicle.com



VAHKI
PUURAKH
8614



VAHKI
BORDAKH
8615



VAHKI
VORZAKH
8616



VAHKI
ZADAKH
8617



VAHKI
RORZAKH
8618



VAHKI
KEERAKH
8619



BIONICLE®

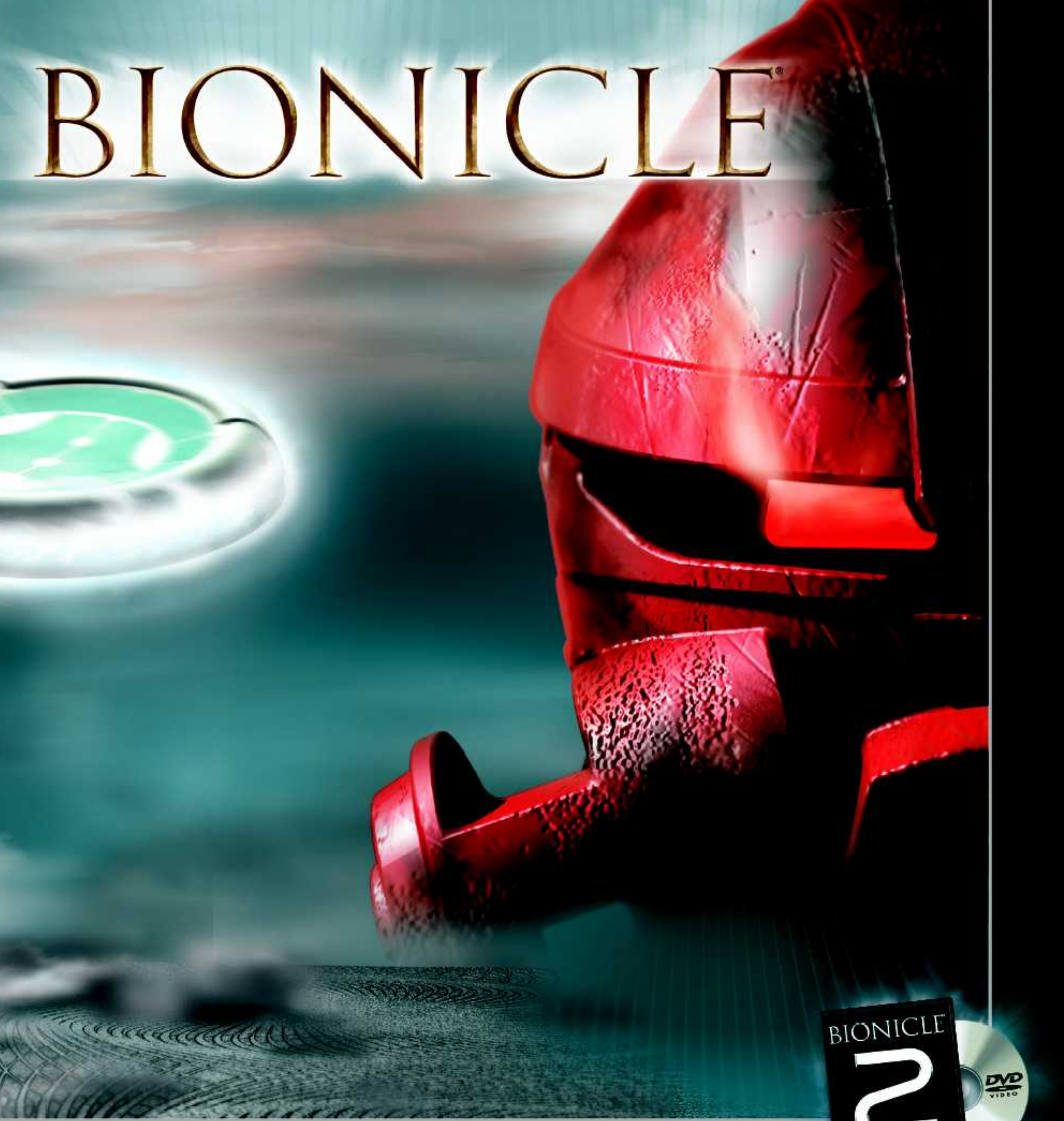

BIONICLE
2
LEGENDS OF
METRU NUI





LEGOLAND®



www.LEGOLAND.com

Win!
Gagne!
Gewinne!
当たります



WIN LEGO® PRODUCTS

We would like to know what you think about our new LEGO® product. If you could help us by answering a few questions you are in with a chance of winning an exciting LEGO prize. It will only take you about 3 minutes! Log on to the web address below for further instructions.



GAGNE DES PRODUITS LEGO®

Nous aimerions savoir ce que tu penses de ton nouveau produit LEGO®. Si tu veux bien nous aider en répondant à quelques questions, tu recevras peut-être bientôt un fantastique prix LEGO. Et cela ne te prendra que 3 minutes environ ! Tu obtiendras davantage d'informations en visitant le site Internet indiqué ci-dessous.



GEWINNE LEGO® PRODUKTE

Wir sind sehr an deiner Meinung über dein neues LEGO® Produkt Interessiert. Wenn du uns den Gefallen tust und ein paar fragen beantwortest, kannst du einen tollen LEGO Preis gewinnen. Das Ganze dauert nur etwa 3 Minuten! Gehe einfach zu der unten angegebenen Webadresse - dort findest du weitere Informationen.



Estimado usuario LEGO®

Al contestar algunas preguntas en inglés, francés, alemán o japonés, en el sitio www.acnielsen.aim.dk/lego, podrás participar en el sorteo de algunos valiosos premios LEGO®.



Caro Consumidor da LEGO®

Ao responder a algumas perguntas em Inglês, Francês, Alemão ou Japonês no endereço www.acnielsen.aim.dk/lego irá participar num concurso para ganhar valiosos prémios da LEGO®.



Kedves Ifjú LEGO® Vásárló

Ha ellátogatsz a www.acnielsen.aim.dk/lego honlapra és ott angol, francia, német vagy japán nyelven megválaszolsz néhány kérdést, akkor részt veszel egy versenyben, amelyben értékes LEGO® díjakat nyerhetsz.



抽選でレゴ®製品が当たります

私たちは、皆さんがお買い求めのレゴ®製品についてどんな感想をお持ちか、知りたいと思っています。質問に答えて、楽しいレゴ®製品の抽選に応募しませんか。アンケートの回答には、ほんの3分ほどしかかかりません！詳しくは、以下のウェブアドレスまでアクセスしてください。

LEGO, the LEGO logo, the CLIKITS logo and BIONICLE are trademarks of the LEGO Group. ©2004 The LEGO Group.

www.acnielsen.aim.dk/LEGO



BIONICLE[®]

2

LEGENDS OF
METRU NUI

